

14-03-00 9AM

Bob Cooper's

MARCH 15 2000

SatFACTS

MONTHLY



Reporting on "The World" of satellite television in the Pacific and Asia

IN THIS ISSUE

**ATV1, ATV2
Start - Ethnic
Roundup**

**Terrestrial
Blackspot
Basics**

**Settling
Satellite Dishes
"out of court"**

- ✓ Latest Programmer News
- ✓ Latest Hardware News
- ✓ Latest SPACE Pacific Reports
- ✓ Cable TV Connection

Vol. 6 ♦ No. 67
Price Per Copy:
NZ\$9/A\$10/US\$7

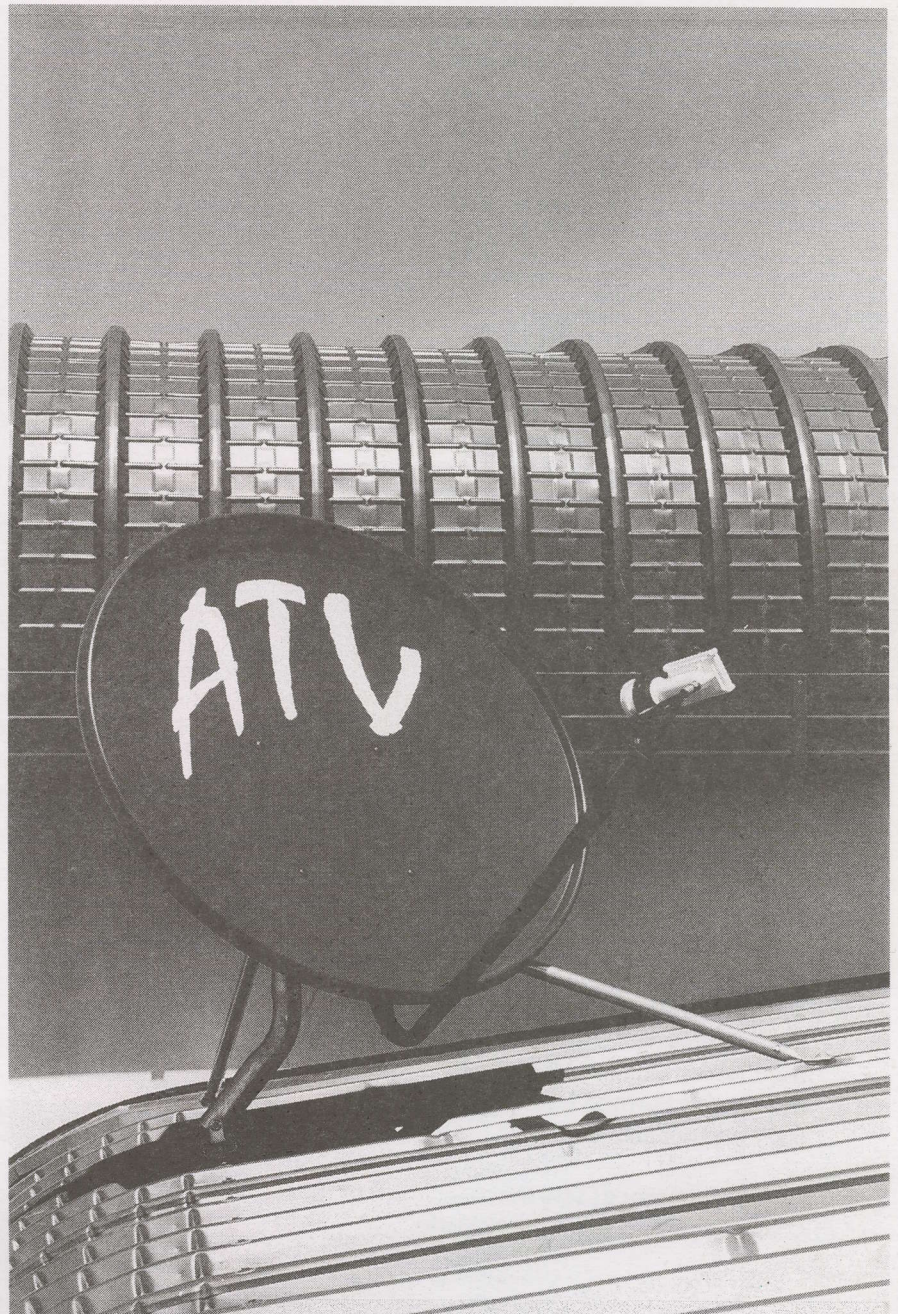

Paraclipse[®]

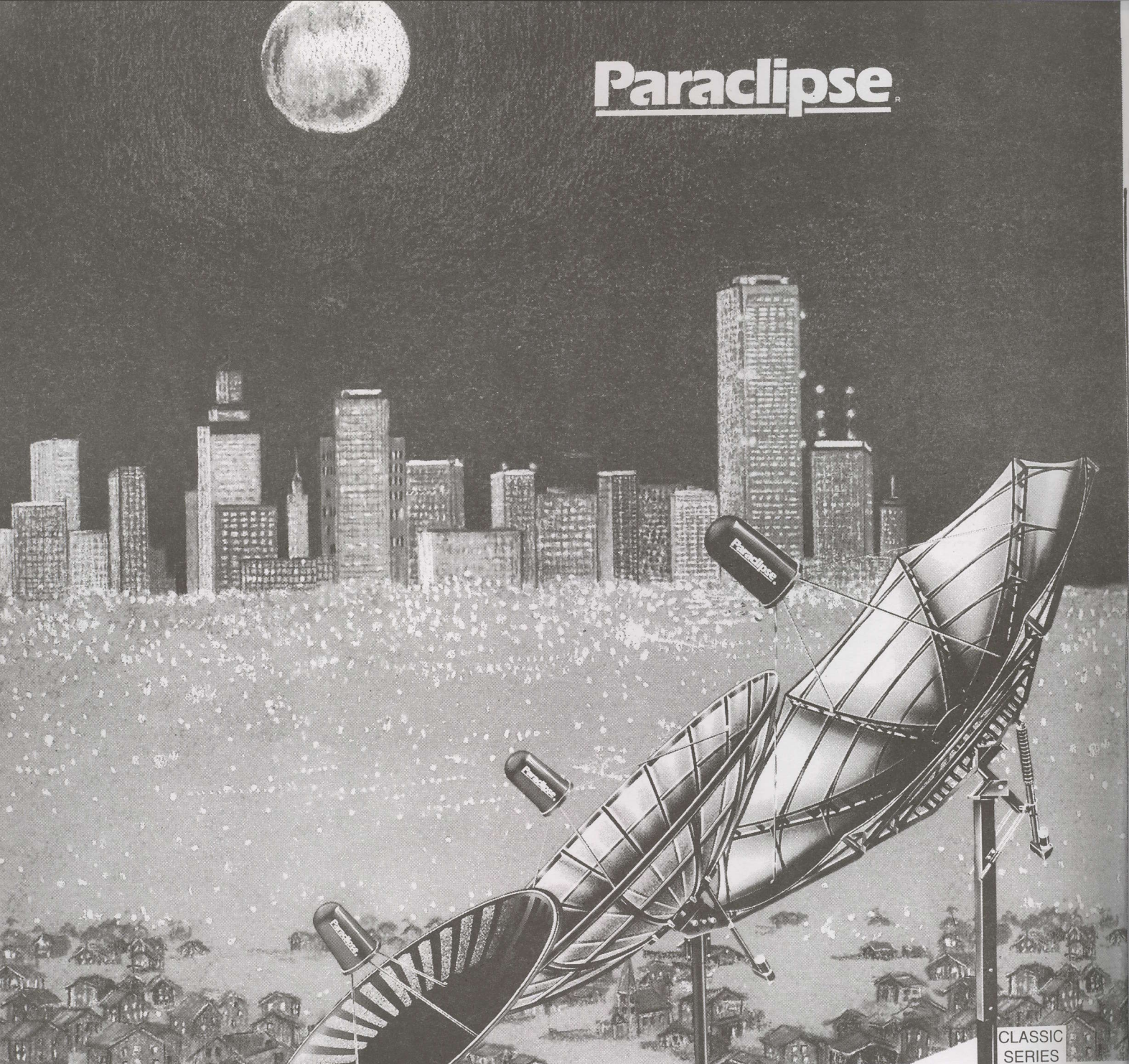

HYDRO
SERIES

ECLIPSE
SERIES

CLASSIC
SERIES

When quality, strength, and accuracy are your main requirements, **Paraclipse** antennas are your first choice.

Only **Paraclipse** offers such variety; four distinctly different series: the Truss-Ribbed Classic, the Courier Deliverable Eclipse, the Stretch Formed Hydro, the Commercial Patriot.

Every **Paraclipse** model sets the industry standard in its class, worldwide.

Distributed in Australia & the Pacific by

**SATECH Satellite
Communication
Technology Pty. Ltd.**

18/477 Warrigal Rd, Moorabbin
East, Victoria, Australia 3189
tel 61-3-9553-3399
fax 61-3-9553-3393

Paraclipse[®]
HIGH PERFORMANCE ANTENNAS

Paraclipse Inc.
2271 29th Avenue East, Columbus, Nebraska USA 68601
Telephone: (402) 563-3625 Fax: (402) 564-2109

★ **MADE IN
AMERICA**

SPACE PACIFIC REFERENCE MATERIALS

(updated March 15, 2000)

to help you do a better job, profitably

Some items in limited quantity (marked LtdQty); many have special SPACE member discounts

SPACE Pacific Report (# 9901, 9902, 9903, 9904)

The television programme, direct to you from digital master on E240 VHS tape, PAL format of course. Show 9901: "It is your signal, too" and "Fun and games with the spectrum analyser." Show 9902: "Feeds and LNBS" - understanding how products differ. And, "Mark Long's Thumbnail History of home satellite TV" featuring the real pioneers of the 70s and 80s! Show 9903: "Dish antenna critique," why some dishes work better than others, plus Mark Long on installing your own dish, and, Richard Brooks on PVRs. Show 9904: "Who buys DTH systems?" explores the marketplace, plus, "Understanding Tiny Parts" looks at connectors, line-amps and splitters. Four hours as currently running on Mediasat - digital mastered to you for the exceptional price of \$55 including shipping and two bonus items - "Satellite Television (The Booklet)" featuring material by Sir Arthur C. Clarke. In stock, shipped within 72 hours. (No SPACE discount)

Shows 9905, 9906, 9907, 9908 & 9909

The television programme - the latest releases (as broadcast SUNDAYS on Mediasat). As above. Show 9905: Robin Colquhoun and the Dr Overflow software for the Nokia; Show 9906: How the uplink works - possibly the best programme topic ever created. Show 9907: Part two of uplink. Show 9908: Instructor Mark Long's "Digital Basics." Show 9909: Mark Long's "Installation Basics" with emphasis on Ku service. Shows 9905, 6, & 7 now being shipped. \$60, no SPACE discount.

World Sat TV '92

Close out - a few copies remaining! All of the basic fundamentals are here, at a price that is too good to be true. Hey - the quantity is very limited (LtdQty) and we need to clear out the shelf space. \$10 and if you are a SPACE Member, it comes down 30% to \$7! Having a complete satellite TV reference book doesn't get any cheaper than this.

TB 9404 DTH Systems

Direct to Home: Satellite System Installation Techniques. There are many-many NEW people getting into home satellite system installation. And we receive several calls each day asking us to point them at a "basic tutorial" that will explain how a home dish system works, how you install it for proper performance. This is it. Without question, the very best *quick* tutorial on what a home dish system is, how it works, where the problems develop. If you are new to the DTH field, buy this and commit it to memory. Very slight New Zealand bias, not enough to hurt its value world-wide. And if you are looking into multi-set installations such as motels and hotels and condominiums, also order TB 9405 'SMATV Systems' (below; the pair make it painfully clear where mistakes are commonly made). Also see SatFACTS October, November, December 1999 - for RF Distribution System articles. TB9404 originally prepared by Coop for an Asian DTH technology conference, LtdQty \$10 (SPACE discount).

TB 9405 SMATV Systems

Satellite to room - Commercial SMATV (Satellite) Dish Installations. The easy part is the satellite dish or dishes. The difficult challenge is getting all of those signals - including the terrestrials - balanced and into every room and each TV outlet at the proper level. If you plan to do multiple-outlet systems, start here with this Coop written tutorial. LtdQty and only \$10 per copy while they last! (SPACE discount)

Nelson Parabolic Manual

The Nelson Parabolic TVRO Manual. If you are the type of person who wants to build your own dish (up to 3.7m in size), or, you simply want to understand why some dishes work better than others, this step-by-step "how to build a dish" manual is the "Bible" of an industry. Nelson Ethier was a perfectionist and brilliant with hand tools. It shows here - the ultimate backyard project! Half original price at \$15, LtdQty, SPACE discount applies.

SPACE Pacific Order Form (also see SPECIAL PACKAGES on reverse side)

Please send the following:

SPACE Pacific Report - 9901-9904/ \$55 (no discount); Shows 9905-9907/ \$60 (no discount); Package deal - 9901-9907 (2 tapes)/ \$105 (no discount); World Sat TV-'92/\$10; TB 9404 - DTH Systems/\$10; TB 9405 - SMATV Systems/\$10; Nelson Parabolic TVRO Manual/\$15. Total of order - \$_____ . If current SPACE member, multiply by 0.7 (70%) and

write discounted total here: \$_____

I wish to pay this by cheque (enclosed) VISA card Mastercard
Card number _____ expires ____/____

Ship to (name as it appears on card):

Company _____

Mailing address _____

Town/city _____

Your signature: _____

SPACE Pacific Terrestrial TV Reference Materials

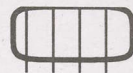
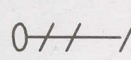
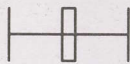
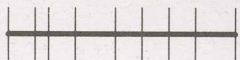

Each of these editions researched, created by "Coop" to help you solve tough aerial problems

TB 9301	Tech Bulletin 9301. Co-Channel & Antenna Phasing. How to grow a single antenna (Yagi, broadband antenna) into a complex array to greatly increase gain, sharpen receiving pattern to eliminate co (same) channel interference. Totally hands-on, very practical, up-to-date. Go from novice to professional!
TB 9302	Tech Bulletin 9302. Weak Signal Reception Techniques. If one cut-to-channel (Yagi) antenna won't do the job, will 2, 4 or 8??? How about 16? Stacking antennas, mating with carefully selected masthead amps, is an art. This explains how to do it for professional results up to 300 km from TV stations.
TB 9303	Tech Bulletin 9303. UHF - The Frontier. Using parabolic style antennas surfaced with low-cost poultry mesh, build UHF dishes up to 40 feet in size to extend UHF off-air reception out to 300 km. And - learn the tricks to "squirt" signals from a hilltop to a valley below using low-cost receiving equipment.
TB 9304	Tech Bulletin 9304. Beating Noise Interference & Combining Cross-Pole Signals. When TV and FM signals are weak, man-made interference from appliances, power lines can kill reception. Step-by-step instruction for identifying, locating, fixing noise sources + unique method of combining cross-pole TV signals.
TB 9305	Tech Bulletin 9305. Cable Television - Fact & Fiction. The story of how a cable TV system is designed, built, operated. The perfect "So this is how it works!" report. Who knows - you might even like the concept so well you take out a mortgage on your home and wire your town!
Lost Art	Lost Art of Rhombic Antennas -27 dB of gain VHF & UHF. Everything you need to know to build the most sensitive VHF-UHF receiving antenna ever created. Rhombics are used for virtually all long haul military circuits. Includes super-Rhombic LaPorte design. 300 km? A piece of cake!
40' Dishes	20 to 40' Poultry Mesh (Chicken Wire) Parabolics. Complete instructions to build UHF-TV off-air reception antenna system combines low cost reflector materials with Redwood or other durable "struts." 20 to 25 dB of gain, out to 300 km UHF reception. A backyard project with earnings potential.
Half- Bolics	World-Famous Frias Half-Bolic Reflector. Amazing design allows simultaneous reception over sizeable arc of transmission locations. City grade (80 dBuV) reception from distances of 280 km on VHF (45 MHz) through UHF (900 MHz). This is huge, but easily the best all-around deep-deep fringe antenna system.
NOTE!	NEW to ABA Terrestrial TV Blackspots? Order TB9301/9302/9303/9304/9305 "Special Package" below (\$40) to quick cram ALL of the problems associated with "ABA Proof" of Blackspots!

ORDER FORM - and special discount packages

Please send the following:

- TB 9301/\$10; TB 9302/\$10; TB 9303/\$10; TB 9304/\$10; TB 9305/\$10; Lost Art-Rhombic/\$20; 20-40' Dishes/\$20; Frias Half-Bolic/\$20 - or
 TB9301/9302/9303/9304/9305 - \$40 -or- Rhombic/ 20-40' Dishes/ Half Bolics - \$50 -or-
 TB9301/9302/9303/9304/9305 + Rhombic/20-40' Dishes/Half Bolics - \$80.

Total of order - \$ _____; If current SPACE member, multiply total by 0.7 to obtain discount price (NOTE: No discount applies SPACE Pacific Report video) - new discount total \$ _____. I wish to pay this by Cheque (enclosed) VISA Mastercard

Card number _____ expires ____/____

Ship to (name as it appears on card) _____

_____ Company _____

Mailing address _____

Town/city _____

your signature _____

Return to: SPACE Pacific, PO Box 30, Mangonui, Far North, New Zealand or fax to 64-9-406-1083

SatFACTS MONTHLY

ISSN 1174-0779

is published 12 times each year (on or about the 15th of each month) by Far North Cablevision, Ltd.

This publication is dedicated to the premise that as we enter the 21st century, ancient 20th century notions concerning borders and boundaries no longer define a person's horizon. In the air, all around you, are microwave signals carrying messages of entertainment, information and education.

These messages are available to anyone willing to install the appropriate receiving equipment and, where applicable, pay a monthly or annual fee to receive the content of these messages in the privacy of their own home. Welcome to the 21st century - a world without borders, a world without boundaries.

Editor/Publisher

Robert B. Cooper (ZL4AAA)
Office Manager
Gay V. Cooper (ZL1GG)

Reaching SatFACTS

Tel: 64-9-406-0651
Fax: 64-9-406-1083
Mail: PO Box 330
Mangonui, Far North
New Zealand
Email: Skyking@clear.net.nz
<http://www.satfacts.kwikkopy.co.nz>

Subscription Rates

Within NZ: \$60 p/y
Australia: AV-COMM Pty Ltd, PO Box
225, Balgowlah, NSW 2093
61-2-9949-7417
Elsewhere: US\$60 p/y
All copies sent via airmail fast post
world-wide

ERRATA

SatFACTS Copyright 2000 by Robert B. Cooper; any form of copying is a violation of our international copyrights. Advertising rate sheet available upon request.

COOP'S COMMENT

In the February 15th SatFACTS, on the "insert card" to your left - facing this page - we reported the status of the SPACE Pacific Report television programme. Nine shows had been completed, 540 minutes of television time, a tenth was ready for final completion pending funding from the industry.

The good news is that Joe Bonavia of Ikusi Australia NZ Pty Ltd. arranged for corporate funding to get SPR 9910 to air. It will be worked into the Mediasat (Sunday) schedule sometime in April. There is bad news as well.



From "CBS Evening News," October 31, 1978.
Times change, and ageing is inevitable.

For now, the original ten shows will circulate for a period of time on Sundays through the kind support of Paul Mullen at Mediasat (see p. 28 for schedule). The Westlink series which began in November and ran through late January on their Aurora service channel is finished and we are indebted to the people at Westlink for their support as well.

Where does that leave us? Well, when the Mediasat run concludes, the industry will simply be without a "video presence" on satellite. This shortfall in industry funding happened at a time when we had a new, very generous offer to have the programmes relayed throughout the Pacific and Asia on a powerful Intelsat transponder. That having new viewers in Japan, the Philippines, Fiji and the western USA would have made any real difference in the ultimate success or failure of this project is unknown. It is ironic that satellite programmers saw value in the series that apparently the receiving end of our industry did not.

As we explained in February, the mechanics of creating a 60 minute show are very basic. New material is shot in digital, mixed with older material held in the archives in NTSC and PAL, and a new digital master is created. In the process, 15-20 year old analogue tapes are being "preserved" for future generations by the digital conversions. As we have discovered, many of the original NTSC tapes shot live "when it happened" are very close to total disintegration (time is not kind to human cells or 3/4" videotape). Unfortunately, without funding to continue SPR, most of the remaining NTSC originals will now simply dissolve into head clogging clumps of inert plastic. We gave it out best shot - and now it is time to move on into the future.

In Volume 6 ♦ Number 67

ATV1, ATV2 "Up" / Roundup of Ethnic Services -p. 6

Terrestrial Blackspot Basics -p. 12

Departments

Programmer/Programming Update -p.2; Hardware/Equipment Update -p. 4; SPACE Pacific Report (Settling zoning disputes "out of court") - p. 20; Cable TV Connection (Spiders and the sun); SatFACTS Digital Watch -p. 24; Supplemental Digital Data -p. 26; SatFACTS Analogue Watch -p. 27; SPACE Pacific Report - TV Show schedule -p. 28; With The Observers -p. 29; At Sign-Off (Watch out for fibrespheres) -p. 32

-ON THE COVER-

Indian ATV1, ATV2 to small dishes launches (p. 6).



March 15, 2000

Television as a training and information distribution tool has been with this industry since 1978. "Satellite Magazine" was the original - one hour, twice a month, offering I put together for CATA - the Community Antenna Television Association (USA). Several hundred (209 to be precise) "shows" later, we come to SPR 9910.

Our "plea" for industry funding, at both the individual and corporate level, in SF for February apparently fell upon totally deaf ears. At this point in time, SPR 9910 will be the final show. Fewer than 10 people responded to the request for funding.

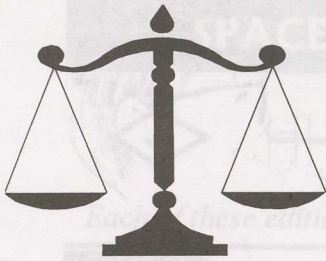

L
E
T
T
E
R
S

Support for SPR

"Re your request in the February issue of SatFACTS for financial assistance in continuing the SPACE Pacific Report. I would like to contribute, cheque enclosed. I am a little too age-challenged to re-enter business but have been involved with radio since 1930, amateur radio since 1934, Member of IREE since 1945 and I find it very satisfying to be involved in electronics in any form as a hobby - such as FTA satellite reception. The weekly telecast plus the monthly SatFACTS are part of the pleasure of my hobby. It is a pity that the monthly magazine is not available to a wider range of people. Or, is it more the nature of being a 'trade magazine'?"

Name withheld upon request, Australia

SPR's funding came up terribly empty after our plea for support (see p. 1, here). But those who did contribute should be pleased to know the money is going towards additional programming on a one by one basis - we won't be able to script and do the ten new shows we hoped for at this time, but as the funds trickle in, each time we reach the magic \$1,300 plateau, another show will be created. SatFACTS is terribly complex for non satellite enthusiasts and we daily refer people to the SPACE Pacific "Satellite Television - The Space Age Magic Carpet Ride of the 21st Century" as well as TB9404 ("DTH Systems") for the basics of what makes it work.

SPR changes?

"Can you advise what is happening with the SPACE Pacific Reports on Westlink? I'm really hoping that it has not stopped being available on Westlink because of a shortage of funding. Keep up the good work and thank you for a great magazine!"

Gary Luxton, NSW

Westlink has elected to not repeat shows 9901-9909 until there is a newer series, at which time they promise to restart with 9901 and carry on to the end of the new shows. But they will run one day each only, not a full week for each show as previously.

iCraveTV?

"I still cannot get iCraveTV to load on my PC - what is the story?"

Elroy Hirsch, Victoria

iCraveTV, facing millions of US dollar fines for being bold enough to grab off air TV signals and streaming them on the web, has agreed to shut down "until we can be certain that only Canadian viewers are able to access the service." That may be next month or never. They have additional problems at home facing separate lawsuits from the Canadian broadcasters who are just as angry as the US broadcasters and copyright folks. Like most pioneers in any new field, for now they have "Indian arrows protruding from their back side."

PROGRAMMER
PROGRAMMING
PROMOTION

UPDATE

March 15, 2000

TPG says they are accepting Boomerang satellite TV clients. Originally promised 7 channels has become 5 (Animal Planet, Cartoons/TNT-TCM, CNN, CNNfn, ESPN). How it works: Customers may register on-line (<http://www.tpg.com.au>), by telephone (1300-360-855). If customer lives in or near Sydney, Penrith, Gosford, Kiama/Wollongong, Lake Macquarie/Newcastle, Melbourne, Brisbane, Southport/Gold Coast, Canberra, Adelaide, Perth, Hobart, Launceston or Darwin - they can have unlimited Internet use through normal telephone line modem for A\$19.95 per month. If they live elsewhere (within Australia), \$19.95 per month for 20 hours use. Once signed up for Internet, they are then qualified to have TPG Boomerang TV off of PAS-8 Ku (12.725Hz, Sr25.728, 7/8). They can purchase (and own) a complete 65cm dish + IRD + + + system for A\$498 (\$399 cost plus \$99 "set up fee"), or, optionally A\$199 down and \$10 a month to "rent" the same system. No monthly charges for the TV service as long as they continue to be TPG Internet clients. Installation? Extra - TPG provides a list of installation firms in the customer's area. Where 65cm dishes won't work? System costs more. No, deal is not offered in New Zealand (although 2.4m dishes will capture it over southern half of South Island).

Another USA religion service? Paper planning, on-air testing for PAS-2 underway to link a third religion based full-time telecaster into the Pacific. Specific receive sites for Australia (3 in Eastern Australia), plus New Zealand, Tonga, Samoa, and PNG (one each) are planned. How the transmissions will be distributed after landing at these points is not clear at this time. First two? Trinity and Seventh Day Adventists.

Cantonese - missing language - coming soon to PAS-8 Ku service for Australia. TVB, world's largest Chinese broadcaster with huge archives of past programming, will uplink from Television City (Hong Kong) to PAS-8, feeding back to Australian homes with 6 channels of Mandarin, 6 more Cantonese. Target date is "June" - no other details at this time. Contact is Patrick Wong (General Manager, TVB Australia) at (610)2-9283-0188. Home installations will be done by Comet.

Name change. TNT Movies (Turner Network Television) becomes TCM (Turner Classic Movies) April 1. Actually, TCM has been the name in other world parts for nearly one year - including the Canal+ bouquet offering on I701 which launched in December for the Pacific.

Not easy. Sydney's Belrose Aurora and beyond uplink site for Optus has been a troublesome location for TI (terrestrial interference) for more than a decade. Now comes Asia TV Pty Ltd and their 3m off-Thaicom dish attempting to receive clean feeds from Lashkara (Punjabi) and Gujari (Gujarati) services at the Belrose site. ATV has them being relinked to Aurora B3 12.532Vt. The 3m dish is to be replaced by a 5m, situated to minimise TI problems, "hopefully before 1 May."

Central 7 has sent letters to satellite TV dealers and installers throughout Eastern half of country urging them to work with the satellite TV broadcaster to expand their coverage. New ABA rules governing Blackspots (see SF February, p. 6) have made it possible for satellite broadcasters to aggressively pursue new viewers.

USA's DirecTV, operating direct to home pay-TV there and in Japan, has quietly begun registering their corporate name, trademark and Internet identity throughout the Pacific. Is there a message here?

Deutsche Welle now reaches 104 million homes, 4 million more than they targeted for end of year 1999. Biggest gains were in Asia.

NG754 an Open and Shut case for noise

Measure frequency response of entire TV distribution systems, cable and coupler attenuation, even align filters and test amplifiers
Around 6 hours of fully portable use from internal re-chargeable batteries
High signal level out, measures as approx. 77dB μ V on a typical TV instrument
Audio Modulation with a 1KHz audio tone provided
Measure reflected power too with P275/75 bridge
On board 2dB step Attenuator 0-30db included

NEW!

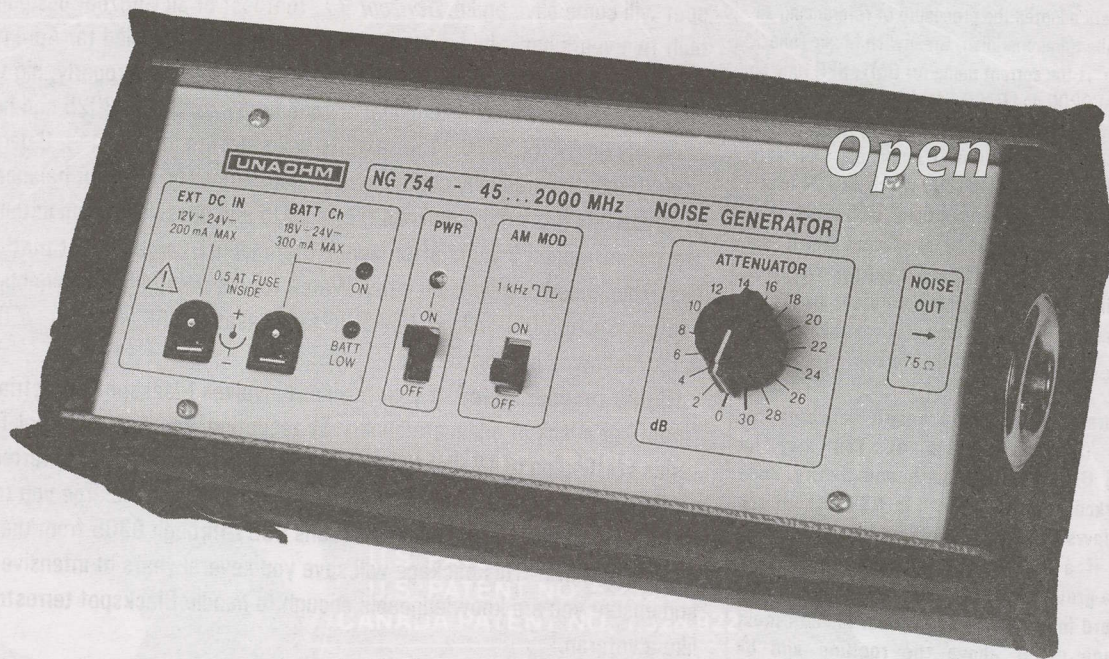

Noise as a wideband signal source allows all the most important radio frequency measurements to be made of any device.

Unaohm's new NG754 noise generator creates a substantially stronger signal than most noise generating instruments in its class, making it useful for a wide range of RF measurements. The NG754 output measures as about 77dB μ V on an instrument with a 1MHz resolution bandwidth. Generating a signal of this amplitude that is equivalent to hundreds of TV channels over a frequency range beyond 45 to 2,000MHz, is no easy task.

Actual frequency response of cable, couplers, and even filters with depth greater than 50dB can be displayed on instruments with spectrum analysis, or even a simple signal level meter. Included is a 0-30dB 2dB step constant impedance attenuator, and switchable 1KHz AM audio modulation that assists you to identify the test signal.

NG754 can also be used to show the real time frequency response of TV distribution systems, by inserting the signal at the head end. The internal rechargeable battery will run the instrument for around 6 hours continuously, or for bench type applications an external supply/charger is included.

Even distance to a coax cable fault can be calculated with respectable precision using the calculator (included) and a BNC T piece.

Used with a reflectometer bridge like Unaohm P275, Return Loss or VSWR of any device can be properly measured. As reflected power relates directly to an increase in Bit Error Rate, this measurement is likely to be more important than ever for digital TV distribution systems.

Less expensive noise generators are available, but the ones we have seen don't generate the high level of the NG754, and are not as convenient to use. Why not make a noise with Unaohm soon?

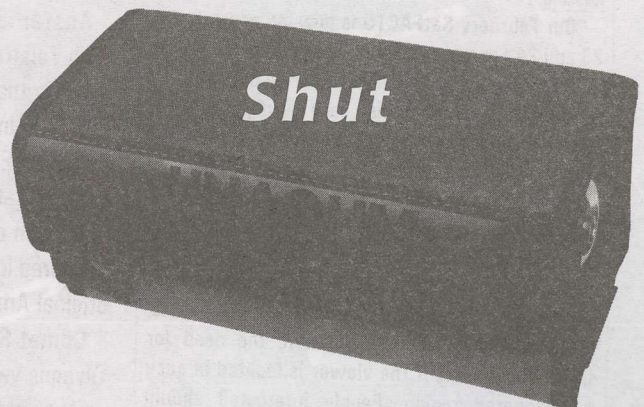

UNA OHM

Another quality product from

Lacey's
Australia

12 Kitson St. Frankston VIC 3199
Tel:(03) 9783 2388 Fax:(03) 9783 5767
e-mail: placey@netlink.com.au

SatFACTS March 2000 • page 3

UTC?

"My husband has installed a satellite dish and relevant decoders and has a subscription to SatFACTS. He would like to view a program listed as starting at 0700 UTC; please advise what UTC stands for."

Jan Court, Australia

With the world divided into 24 major time zones and another dozen half hour variations, listing programming times (such as the SPACE Pacific Report which runs at 0700 UTC on Sundays) can be confusing - "what time at my house???" Back in the late 1920s, the world's broadcasters adopted the procedure of referencing all time to the prime meridian, Greenwich Mean Time (GMT). UTC is the current name for GMT. SPR runs on Mediasat at 0200 and 0700 GMT/UTC Sundays. Start by knowing what the time offset is at your location from London, England. If it is 10 hours, add that 10 to our listed time (10 + 7 = 1700 which on a 24 hour clock is 12 noon + 5 hours or 5pm). UTC avoids the problems of summer time (it never changes even if your local time zone shifts an hour) and leap frogs over those strange half-hour offsets where politicians insist on putting their constituents 30 minutes out of kilter with the balance of the world.

Confusion

"Reference safety and health concerns for installers (SF February, p. 4). You may be confusing Occupational Health and Safety Code with Workcover requirements in NSW. There are specific laws regarding working on roofs. For example, if a worker is more than 1.8 meters above the ground he must be attached by harness and lanyard (mine cost \$300). Also, ladders must extend one meter above the roofline and be attached at the top. There is a small explanatory booklet available from NSW Workcover. I understand these requirements are mandatory and the fines for violation start at \$500. This may be something that SatFACTS can investigate as the rules state 'ignorance of the requirements is not an acceptable defence.'"

Brian Parry, Down to Earth Antenna Service

We admit to being confused - are there readers who can clarify the requirements of OHS and the Workcover?

Missing

"Our February SatFACTS is missing pages 9, 10, 23 and 24 - can you resupply via fax?"

Carolyn Groves, Nationwide Antenna Systems

With thousands of copies each month, a few are bound to be imperfect. February was a particular problem and we apologise on behalf of our printer.

Larger Blackspot definition coming?

"The Department of Communications, Information Technology and the Arts, has commissioned a TVNZ consultancy to determine if 'blocks' of area can be defined as Blackspots, which would if enacted eliminate the need for specific approvals if the viewer is located in such a designated region. People interested should contact the TV fund Section at 02-6271-1000."

R. Longman, ABA

A welcome move - many of our installers have been contacted by Jennifer Levy of the Television Fund Unit seeking local information for their study.

HARDWARE EQUIPMENT PARTS

UPDATE

March 15, 2000

145E. Long short on signal (many possibly do not realise a Russian satellite has been there for a decade - operating with TV on board!), now the prospect this orbit spot will come alive again. *Gorizont 33* - that last of all Gorizont designed satellites, built five years back, laid in storage hence - is now scheduled for April (yes, *this* April) launch by Proton rocket from CIS. If it goes and operates properly, big time global signals on 3675, switchable global or zone on 3725, 3825, 3925 and hemispheric coverage on 3775, 3875. The satellite will start life inclined (+/- 2 degrees), over first 20 months gradually come down to geostationary, then for balance of life progressively grow more inclined returning to and passing beyond initial 2 degree start point around 5 years after launch. April launch *target* is just that - Proton lifter has experienced problems recently. Watch for successful launch announcement of Express 6A (to 80E), followed by Eutelsat Seasat to 36E and then - *if* the first two work - followed by Gorizont 33.

Highly recommended. If your business involves Blackspot terrestrial reception "proof" of a lack of adequate quality TV reception, see our terrestrial TV basics series starting on p. 12. For the very best detailed course on how terrestrial TV works, and why it does not when it is less than perfect, we urge you to order the SPACE Pacific package of Tech Bulletins 9301 through 9305 from the order card facing p. 1 here. This package will save you several years of intensive learning effort and ensure you are knowledgeable enough to handle Blackspot terrestrial situations like a veteran.

Hardware for ATV. While Australia has a selection of distributors to handle antenna, LNBF and IRD needs, New Zealand's choices are few and far between. Telsat Communications (06-356-2749) is one - Hills Industries (09-262-3052) supplied the 90cm dish, LNB, and mount to Satcom NZ for the installation show on our front cover.

Speaking of Hills. A new series of single channel and agile modulators has been announced, this time with vestigial sideband filtering - their present line occupies two channels at a time but the VSB models are finally single channel wide. Welcome to the 21st century!

Austar launches Interactive TV. Buried under their announcement to join forces with Telstra for invasion of the new Zealand pay-TV, telephony market (see p. 32, here), is the quiet news Austar is now formally operating their long promised "satellite Interactive TV system." Try (FTA at press time) Optus B3, 12.376Hz (Sr 29.473, FEC 3/4) for a look-in to see a typically 2 minute video clip looping through an explanation.

Korean created clone copies of Chaparral co-rotor dual C and Ku feedhorns have appeared in Hong Kong and Singapore with pricing approximately 1/3rd of the same original American product.

Comet Satellite & Cable has won contract to install "CATV cabling" for 34 Olympic venues. System will provide multi-channel TV service to visiting journalists and athletes, and will be dismantled after games.

E34 gone on Mediasat. Annoying "E34" overlay on UEC receivers when tuned to Mediasat bouquet on Optus B3 is history - software changes. SPACE Pacific Report is now "blemish free" during Sunday transmissions to 642 IRDs.

Third generation digital set-tops, including satellite IRDs, shown by Taiwan sourced ADB, are leading edge of next plateau of technology. Versions include high speed Internet with built-in "security" to stop credit card numbers from being pirated.

ADL[®]

BECAUSE PERFORMANCE IS ALWAYS YOUR FIRST PRIORITY

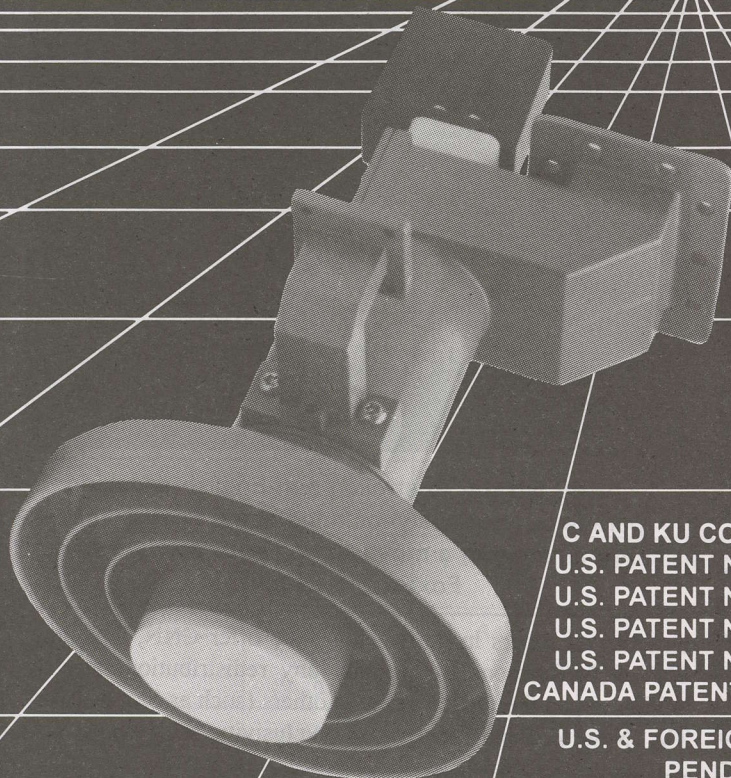

**RP3-CKU/ International
Adjustable Scalar Ring Feed
with Extended C Band**

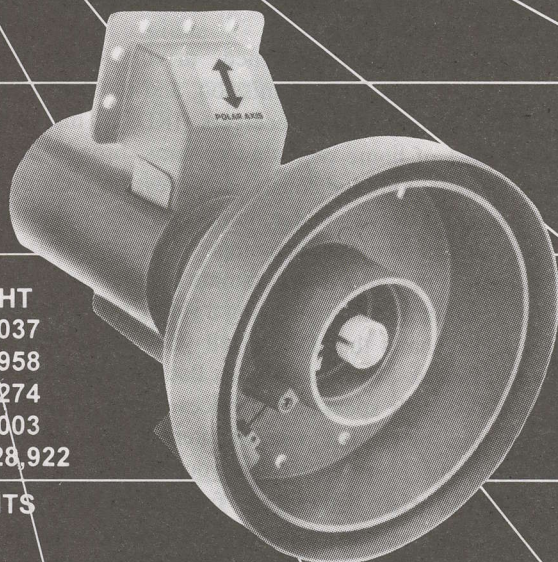

RPI-CKU Feed

C AND KU CO-BORSIGHT
U.S. PATENT NO. 4,903,037
U.S. PATENT NO. 5,066,958
U.S. PATENT NO. 5,107,274
U.S. PATENT NO. 5,255,003
CANADA PATENT NO. 1,328,922

**U.S. & FOREIGN PATENTS
PENDING**

ADL HYBRID MODING CIRCULAR POLARIZED INTELSAT FEEDS WITH EXCLUSIVE T.I. REJECTION



RP1-CP400



CP-300



CPOR-100

- C BAND LINEAR & CIRCULAR • C/KU LINEAR & CIRCULAR • KU 12 GHz FEEDS
 - INTELSAT 4 GHz CIRCULAR • ARABSAT S BAND FEEDS
- OPTIONAL: CO-BORSIGHT S BAND

2216 AGATE COURT, UNIT B, SIMI VALLEY, CALIFORNIA 93065 • (805) 526-5249 • FAX (805) 584-0634

NEW ADL Web site - www.adlfeed.com

Roundup of ethnic television service packages for South Pacific

What is the fastest growing category of satellite service in the Pacific? If measured by bandwidth, Internet. If measured by content, ethnic television. Provided you define ethnic in a new, modern way.

For nearly two decades, the primary "language" of satellite television was English. Programmers that created English language programming did better, initially, primarily because the only people who could afford satellite dish systems were the more affluent and English was a second (if not first) language to most.

Then digital happened, driving down per-programme -channel costs for transmission, and more recently, being met by lower cost digital receivers (IRDs). This, in turn, reduced the cost of home receiving systems, broadening the potential user base. Simultaneously, compression technology has made it possible for a greater number of programming channels to occupy a single transponder. This, in turn, has created a situation that allows programme bundlers to offer more diverse programming channels using a single transponder.

The charts that follow tell you the identity and reception parameters of virtually all Pacific region-available ethnic (non-English speaking) services. Look first in the left hand column for the language of interest, then under that language locate the best service for your region. The bold face (i.e., **PTV/World**) listings are free to air (FTA) - analogue or digital as applies. Under each listing, a telephone number, Internet web site or email address for contacting the broadcaster. Non bold face listings (i.e. Canal+ Bqt) are conditional access, subscriptions available (contact numbers provided).

Not everything is neat and orderly. The Filipino Channel (from Manila broadcaster ABS-CBN) is exclusively available inside of Australia from TARBS. But, TARBS gets their feed of TFC from PAS-2 (3743 Vt) in PowerVu format. TARBS does not reach New Zealand (or other Pacific locations outside of Australia) so they cannot on-sell TFC to you there. It is possible - but time intensive - to convince ABS-CBN that you are not trying to end run TARBS, and gain paid-for authorisation of TFC outside of Australia. But you may end up being told to take the (subscription) feed from PAS-2 4028/1122Hz which, unfortunately is not MPEG-2 but something called Digicipher 1 (General Instrument DSR1500 is one such model receiver). Yes, that is the same format originally used by Galaxy before they adopted Iredeto/MPEG-2. PNG viewers have been able to get ABS-CBN authorisation in this way (telephone 63-2924-4101 and ask to speak to a network affiliate manager - they do speak English.)

Not all "ethnic" services are totally in their home language; Deutsche Welle (for example) inside of the European Bouquet is 12 hours German, 11 English and 1 Spanish daily. Australia's TARBS offers two total-English services (CNN, Cartoons/TNT-TCM) as an optional "extra" for ethnic viewers. The Turner/Time method of operating is unlike



TARBS led the Australian non-English speaking parade but curiously included some English (EE) programming in a move to compete with Austar, Foxtel and Optus.

virtually all others in the world - they offer CNN, CNNfn, TNT-TCM/Cartoons to virtually any redistribution operator willing to pay their price whereas others (such as Sky Network TV, New Zealand) insists on exclusivity. Discovery with

TARBS Australia Ethnic Packaging

TARBS grew out of the financial failure of Galaxy pay-TV, using the infrastructure left behind by Australia's first pay-TV firm. Using PAS-8 Ku, service to Australia is in the 65 cm to 1.2m dish range. This is essentially satellite delivered pay-TV with emphasis on specific language speaking (ethnic origin) clients. Many of their service channels are simultaneously available FTA on C-band (for example - Spain, Egypt, French MCM) and their two English language (EE) services (CNN and Cartoon Network/TNT-TCM) are with the launch of TPG's Boomerang TV service available essentially without charge (see p. 2, here). TARBS uses a unique conditional access system created by Taiwan's Mentor Data Systems - built around model STB 3100 IRD. This IRD is totally useless for any service except TARBS with software "limits" built-in to prevent using the IRD to tune-in other services. Best selling service seems to be TFC (The Filipino Channel from ABS-CBN). Their automated telephone service (1300 782 727) promises to get you to an operator that speaks the language of the service you are interested in - we found long waits (ten minutes +) to finally end up speaking to an obviously frustrated English speaking lady. Comet does the installs under contract.

Which ethnic service is where - how do you receive it?

Language	Service	Satellite	Analogue Parameters	Digital Parameters	Dish Size W. Australia	Dish Size E. Australia	Dish Size New Zealand
Arabic	Saudi TV 1	As2		3660/1440Hz Sr27.500, 3/4	2.4m	2.1m	3.0m
Cantonese (to Australia)	TVB HngKng (02-92830188)	PAS-8 (Ku)		Unknown (June target)	<0.9m	<0.9m	will not be available
Egyptian (thru TARBS)	ERTU/ESC	As2 PAS-8 Ku	3642/1508Hz	12.526Hz	2.4m 1.2m	2.1m 0.9m	3.0m+ not available
	ART Austral. 29-23369200	PAS-2		3778/1372Vt Sr13.330, 3/4	3.0m+	2.4m+	3.0m+
Filipino	ABS-CBN 63-29244101 (thru TARBS) 1300-782-727	PAS-2 PAS-8 (Ku)		3743/1407Vt Sr21.800, 3/4 12.526Vt Sr28.067, 3/4	3.0m+ 1.2m	2.4m+ 0.9m	3.7m+ not available
French	Canal+ Bqt 687-438156	I701 (Ku)		11.610Hz Sr30.000, 3/4	not available	1.1-1.8m	not available
	Fashion TV	As2		3796/1354Vt Sr2.533, 3/4	2.4m	1.8m	2.7m
	MCM Asia 33-153646100	As2		4000/1150Hz Sr28.125, 3/4	2.4m	1.8m	3.0m
	TV5 33-144185555	As2		4000/1150Hz Sr28.125, 3/4	2.4m	1.8m	3.0m
	TV5 33-144185555	Palapa C2	4160/990Hz		2.7m	1.8m	2.4m
German	Deutsche Welle 49-3046460	As2		4000/1150Hz Sr28.125, 3/4	2.4m	1.8m	3.0m
Greek	Antenne Pacific	PAS-2		3778/1372Vt Sr13.330, 3/4	3.0m+	2.4m+	3.0m+
	ERT Satellite 30-16066000	I701		3764/1385R Sr29.900, 7/8	4.0m+	4.0m+	4.0m+
Indian (Bangla)	Alpha TV Bangla 91-224939694	As3	4140/1010Vt		2.4m	1.8m	2.7m
(Gujarati)	Gujari Ch.	Thaicom 2/3		3600/1550Hz Sr26.667, 3/4	2.7m+	2.4m+	not visible
(Gujarati)	Gujari Ch. 1300-302-245 09-238-3083	Optus B3		12.532Vt Sr30.000, 2/3	0.9m	0.9m	0.9m
(Hindi)	DD1 National	InSat 2E	3850/1300Vt		2.7m	2.1m	not visible
(Hindi)	Zee News 91-224939694	As3	3940/1210Vt		2.4m	1.8m	2.7m
(Hindi)	Zee TV 91-224939694	As3	3980/1170Vt		2.4m	1.8m	2.7m
(Punjabi)	Alpha Punjabi 91-224939694	As3	3900/1250Vt		2.4m	1.8m	2.7m
(Punjabi)	Lashkara Ch	Thaicom 2/3		3600/1550Hz Sr26.667, 3/4	2.7m+	2.4m+	not visible
(Punjabi)	Lashkara Ch 1300-302-245 09-238-3083	Optus B3		12.532Vt Sr30.000, 2/3	0.9m	0.9m	0.9m
(Tamil)	DD5	Insat 2E	3810/1340Vt		3.0m	2.4m	not visible

Language	Service	Satellite	Analogue Parameters	Digital Parameters	Dish Size W. Australia	Dish Size E. Australia	Dish Size New Zealand
Indonesian	Anteve 62-215222086	Palapa C2M		4055/1095Vt Sr6.510, 3/4	3.7M+	3.0m+	4m+
	Indosiar 62-212510101	Palapa C2M		4074/1076Vt Sr6.500, 3/4	3.7M+	3.0m+	4m+
	RCTI 62-215303540	Palapa C2M		3755/1395Vt Sr8.000, 3/4	3.7m+	3.0m+	4m+
	TPI 62-218412473	Palapa C2M		4184/966Vt Sr6.700, 3/4	3.7m+	3.0m+	4m+
	TVRI	Palapa C2M	3840/1310Hz		2.7m+	2.1m+	2.4m+
Italian	RAI Internation. www.raointernational.rai.it	As2		4000/1150Hz Sr28.125, 3/4	2.4m	1.8m	3.0m
	RAI Internation. 39-633172193	PAS-2		3778/1372Vt Sr13.330, 3/4	3.0m+	2.4m+	3.0m+
Japanese	NHK World www.jp/nhkworld	PAS-8		4060/990Hz Sr26.470, 3/4	2.7m	2.4m	2.7m+
Korean	Arirang TV www.arirang.co.kr	AS3		3755/1395VT Sr4.418, 7/8	2.4m+	1.8m+	2.7m+
Lebonese	LBC Australia www.lbcSAT.com.lb	PAS-2		3778/1372Vt Sr13.330, 3/4	3.0m+	2.4m+	3.0m+
Mandarin (Anhui)	AHTV www.ahtv.com.cn	As2		3820/1330Vt Sr4.418, 3/4	2.4m	1.8m	2.7m+
	CCTV3 www.cctv-3.com	PAS-2		3716/1434Vt Sr19.850, 3/4	2.7m+	2.1m+	3.0m+
	CCTV4 www.cctv-4.com	PAS-2		3716/1434Vt Sr19.850, 3/4	2.7m+	2.1m+	3.0m+
	CCTV4 86-1-68506517	As3	4120/1030Hz		2.4m	2.1m	2.7m
	CCTV4	As2	3960/1190Hz		2.4m	2.1m	3.0m+
(primarily English)	CCTV9 www.cctv-9.com	PAS-2		3716/1434Vt Sr19.850, 3/4	2.7m+	2.1m+	3.0m+
	CETV www.cetv.com	As3	3680/1470Hz		2.4m	2.1m	2.7m

Animal Planet have recently adopted the Turner/TNT approach and this explains the TPG Internet offering of TNT-TCM/Cartoons, CNN, CNNfn, Animal Planet and ESPN as a "free bonus" to TPG Internet subscribers (see p. 2, here). How long will they last?

Ethnic services have experienced a chequered history of failure and change. Five years back, Indian programmer RAJ-TV was highly popular in the Pacific when broadcasting from 130E. RAJ is still going strong, but has subsequently moved to Thaicom 3 and an Asian beam. As a seller / installer of home dish systems, you need to be comfortable that what

you are offering has some chance of staying on the air and on a satellite your customer can "see."

Services operated by national governments (such as Saudi TV1, DW, CCTV, the Indian DD channels) are as "good" as their respective governments. Services operated by giant conglomerates are equally safe although still subject to corporate decision making which could kill them without notice (Zee TV and the Alpha channels). Services operating on short-term satellites (Russian TNT/THT on LMI AP1) will only last as long as the satellite and as this is an inclined orbit, approaching end of life bird with no promise of a replacement

The Most Advanced Free To Air Digital Satellite Receiver

D7-MediaStar

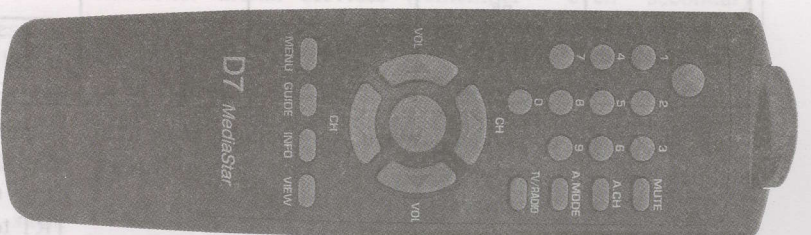
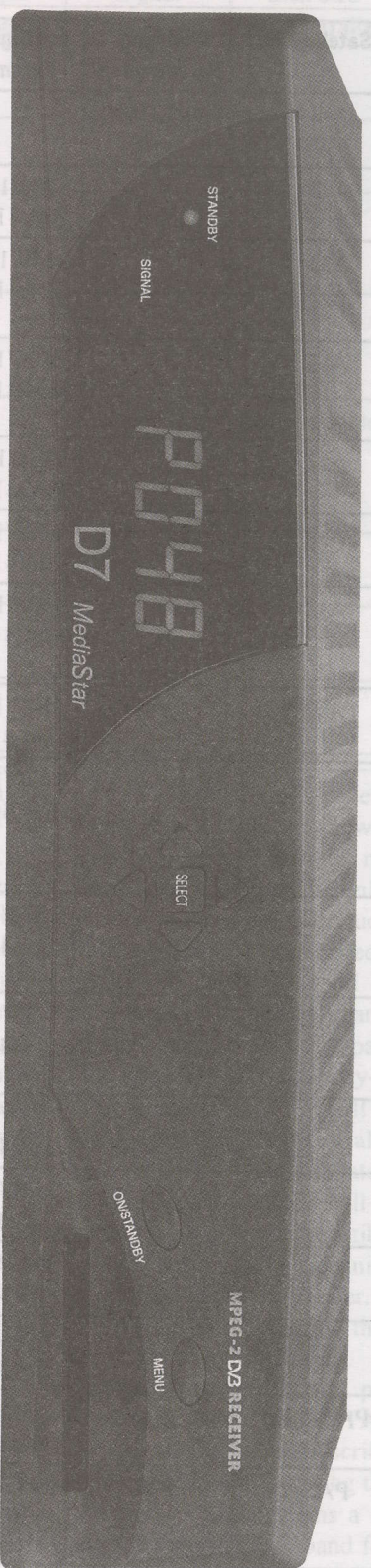

- MCPC/SCPC 2-36 Msym
- Direct channel selection from channel list
- Channel Edit menu Delete, Skip, ON.
- Fast response when changing channels
- No channel over-write
- 200 Video 100 Audio channels
- Automatic search and download
- 22 KHz switch
- PID Menu
- NTSC/PAL Auto switching NO NTSC Glitch
- NTSC converted to PAL-60Hz Free Option
- Audio L, R, Stereo selectable via remote control
- RF Modulator PAL-G, VCR/TV Scarts, RCA Audio/Video, SVHS outputs.
- 90-265VAC-50-60Hz power supply
- Low threshold performance



MediaStar Communications International
24 Bosci Road
Ingleburn NSW 2565 Australia

E-mail opac@bigpond.com
Tel + +61 2 9618 5777
Fax + +61 2 9618 5077

Language	Service	Satellite	Analogue Parameters	Digital Parameters	Dish Size W. Australia	Dish Size E. Australia	Dish Size New Zealand
Mandarin (continued)	Channel [V]	As3	3840/1310Hz		2.4m	2.1m	2.7m
(Fujian)	FJTV www.fjtv.fj.cn	As2		3720/1430Hz Sr4.418, 3/4	2.4m	1.8m	2.7m+
(Guangdong)	GDTV www.gdtv.com.cn	As2		3840/1310Hz Sr4.418, 3/4	2.4m	1.8m	2.7m+
(Guangxi)	GXTV gxtvzb@public.nn.gx.cn	As2		3806/1344Vt Sr4.418, 3/4	2.4m	1.8m	2.7m+
(Hubei)	HBTB 86-277839223	As2		3854/1296Hz Sr4.418, 3/4	2.4m	1.8m	2.7m+
(HeiLong Jiang)	HLJTV 86-4512627454	As2		3875/1275Vt Sr4.418, 3/4	2.4m	1.8m	2.7m+
(Henan)	HNTV www.starhnt.com.cn	As2		3706/1443Hz Sr4.418, 3/4	2.4m	1.8m	2.7m+
	Hunan TV 86-7314501357	As2		3847/1303Hz Sr4.418, 3/4	2.4m	1.8m	2.7m+
(Mongolia)	Inn. Mongolia www.nmtv.com.cn	As2		3830/1320Hz Sr8.400, 3/4	2.4m	1.8m	2.7m+
(Jiangsu)	JSTV www.jstv.com.cn	As2		3827/1323Vt Sr4.418, 3/4	2.4m	1.8m	2.7m+
(Jiangxi)	JXTV www.jxtv.com.cn	As2		3727/1423Hz Sr4.418, 3/4	2.4m	1.8m	2.7m+
(Liaoning)	LNTV 86-2423232945	As2		3734/1417Hz Sr4.418, 3/4	2.4m	1.8m	2.7m+
(Mongolia)	NMGTV 86-4716962041	As2		3830/1320Hz Sr8.400, 3/4	2.4m	1.8m	2.7m+
(Qinghai)	QHTV 86-4716144148	As2		3713/1437Hz Sr4.418, 3/4	2.4m	1.8m	2.7m+
	Shaanxi TV 86-295256780	As2		3813/1337Vt Sr4.418, 3/4	2.4m	1.8m	2.7m+
(to Australia)	TVB HngKng (02-9283-0188)	PAS-8 Ku		unknown (June target)	<0.9m	<0.9m	will not be available
Muslim	MTA Int. www.mtaintl.org	PAS-2		3901/1249Hz Sr30.800, 3/4	2.7m+	2.7m+	3.0m+
Pakistani	PTV/World www.ptv.com.pk	As3	4100/1050Vt		2.4m	2.1m	2.7m
Portuguese	RTPi www.rtpi.rtp.pt	As2	3980/1170Vt		2.7m	2.4m	3.0m+

- well, the danger is obvious. When you combine short term satellites with the economic problems now facing Russia, TNT/THT's future for the Pacific is not bright.

Relay broadcasting

During the past 8 months, a new trend has begun - taking big dish, C-band services from distant satellites and relaying one

or more channels to a high look angle, small dish capable Ku band satellite. First to do this - independent uplinker Mediasat using Optus B3 from Sydney. Mediasat arranged for Turkish TRT to be available off of Thaicom 3 (78.5E, 3551/1599Hz) and reuplinked to B3. Mediasat pioneered use of the Optus Australia + New Zealand beam (90cm dishes in both countries). Initially, this TRT feed was PowerVu FTA, making

Language	Service	Satellite	Analogue Parameters	Digital Parameters	Dish Size W. Australia	Dish Size E. Australia	Dish Size New Zealand
Russian	NTV	LMI AP-1 (inclined)		3675/1475L Sr12.000, 3/4	2.7m	2.1m	2.7m
	TNT/THT www.tht.ru	same		same	same	same	same
Spanish	TV Chile (thru TARBS) 1300-782-727	PAS-8 (Ku)		12.526Vt Sr28.067, 3/4	1.2m	0.9m	not available
(Spain)	TVE www.rtve.es/tve (thru TARBS)	As2 PAS-8 Ku		4000/1150Hz Sr28.125, 3/4	2.4m 1.2m	1.8m 0.9m	3.0m not available
Thai	ThaiTvGlobal www.thaitvnet work.com	I702		12.650Hz Sr17.800, 1/2	not available	1.2m+	not available
Turkish	TRT www.trt.net.tr	Optus B3		12.335Vt Sr30.000, 2/3	1.2m	0.9m	0.9m
(March 2000?)	PayTV1	same		same	same	same	same
(March 2000?)	PayTV2	same		same	same	same	same

some IRDs not function or function poorly. Late in February, the software data stream has been reconfigured to allow any DVB compliant IRD to recover TRT without impairments.

Mediasat's demonstration that you could combine Australia and New Zealand together, and eliminate the software "blocks" that normally accompany PowerVu format transmissions, spurred a new firm called Asian Television Pty Ltd (ATV) to try a similar arrangement with Optus directly. ATV has installed a temporary 3m dish at the Optus Aurora Belrose (Sydney) uplink site where they are taking two Indian channels (one each Punjabi and Gujarati) also off of Thaicom 3. The two channels are then reuplinked to the Optus B3 Aurora service transponder on 12.532Vt.

Because the perceived Indian market is Australia and New Zealand, Optus has agreed to change the 12.532Vt coverage from Australia's National Beam to the same dual coverage initiated by Mediasat. And, because Aurora is Irdeto format conditional access, Optus also agreed to allow the two Indian channels to run in a free to air format for at least a test period (scheduled to close on March 13).

ATV is offering these channels at A\$20 per month for the first, \$30 for the pair. Customers will purchase the Aurora-compatible IRDs and smart card - likely installed price in the region of \$900. The authorisation smart cards will come from ATV. Ku-band relayed ethnic service channels may be an answer to viewers who have been unable to get local approval for C-band size dishes (see P. 20, here).

The seller/installer position

Major services (TARBS, the new TVB Cantonese + Mandarin bouquet) have settled all of their system installation challenges by signing up specialised installation firms (Comet Satellite & Cable has been getting the bulk of this work). Ethnic FTA viewing, using C-band feeds, has remained an activity for independent business people and some of the more successful system sellers report upwards of 100 such installations in the last 12 months.

The TRT (Turkish) service was a hot item, and very controversial in the way it was offered to the market, 6 months ago. That storm has pretty much blown over as well although dish system pricing is unlikely to ever recover from the sub-\$1,000 pricing introduced by the TRT marketers. The TRT service which launched midyear 1999 is "guaranteed" to remain on Mediasat, and FTA, until midyear 2001 as a minimum. During February, Mediasat reconfigured their 12.336 transponder in preparation for the launch of two new (CA - not FTA) Turkish pay-TV service channels. Paul Mullen at Mediasat advises, "It will start when they sign on the dotted line." Translation: Money talks.

Which brings us to the latest offering from ATV. Customers for the Indian services will purchase their own dish systems including an Irdeto compatible IRD. The smart cards through ATV will be the technique for controlling who is an authorised installing dealer. Dealers participating essentially are "free agents" creating their own sales leads, making their own sales and installations.

The "rush" to ethnic programming is a bit of a quiet revolution. Major player TARBS stays well off of page one, quietly adding new subscribers and fine tuning its content. Other players are assessing the prospects for missing language services - Russian seems a likely prospect to Ku size dishes provided a reliable C-band feed can be located (Gorizont 33 - the last Gorizont built and held in storage for years - now scheduled to 145E as early as April - is a possibility). Additional Indian services (remember - even "secondary languages" are spoken by 100 million or more residents) are under study.

The built-in fear (for some it is paranoia) of anything having to do with C-band is now spreading to the ethnic TV world. To reach the largest number of customers with the smallest dish and the least installation problems - Ku is the way to go. Where possible, C-band services are being used more and more for long haul transport while Ku becomes the delivery system for the last link.

You can sell an Aurora Blackspot system if ...

You can prove terrestrial Blackspot reception

The art of producing quality terrestrial reception began in the mid 1930s. Television transmissions to consumer TV sets actually began in 1928 (bet you didn't know that!) using a mechanical system that rotated a round disc (disk) containing a spiral pattern of pin holes through which images were "projected" to a passive (non-electronic) screen. Television "stations" in Chicago, New York City, and Washington (DC) actually operated to a schedule with printed programme lists published in local newspapers by 1929.

Mechanical television was an early starter but held no promise for mass acceptance. Still, between 1928 and 1933, more than 10,000 mechanical TV receivers were sold and probably put to some use in the United States and the UK.

All-electronic television (with a cathode ray or picture tube for receiver display and at the sending end, an electronic camera using a device known as an iconoscope to create the images) was functioning to an acceptable level for consumers by 1935. A Los Angeles experimental TV station began all-electronic scheduled programming in 1934, but the BBC's London transmitter at Crystal Palace is generally conceded to have been the first to transmit to a daily schedule (1936).

Television broadcasting was the first regular user of spectrum above 30 MHz. In a day of gigahertz technology, it is well to remember that radio spectrum use began at very low frequencies (around 100 kilohertz) and extended year by year higher into the spectrum through the 1920s and 30s. Early television receivers had no RF amplifier circuits because the technology and valves (tubes) required simply did not exist - yet.

Even the terminology was imperfect. Radio people referred to the spectrum above 30 megacycles (now we call them megahertz) as "ultra high frequencies" - it would be post World War Two before the spectrum was redefined and that space between 30 and 300 MHz was renamed the "very" high frequency region (while UHF was reused to indicate spectrum between 300 and 1,000 MHz).

Early TV broadcasters operated in the region above 40 MHz, but almost never above 100 MHz. Today, only Australia and New Zealand make wide spread use of the under 48 MHz spectrum for television (Australia channel 0 with a vision carrier frequency near 46 MHz, New Zealand channel 1 at 45.25 MHz) and there are sound reasons why this has happened.

With TV receivers that had no RF (tuner) amplifier stages, and very simplistic (dipole) receiving antennas, getting a TV broadcast receiver to function was a challenge in the late 1930s. Noise was the first problem.

What nobody recognised at the time was the severe impact of manmade devices on any use of the spectrum in the 40 MHz region. The number one culprit was the gasoline operated engine - when spark plugs "fire" they generate a series of radio wave "pulses" which radiate (transmit) away from the engine wiring system. Every car and truck ever built contains some number of radio transmitting devices - each plug - and the

wiring that connects the plugs to the distributor and the vehicle's electrical system through the "coil" are extremely efficient "radiators" of those pulses. By 1950, this problem had been researched and the UK even took the extreme step of requiring every vehicular engine sold in the country have "suppression spark plugs" installed to reduce the impact.

This ignition noise was the bane of good television reception. But it was not the only problem. Power lines and electrical motors were another. Like the vehicle engines, power lines operated without appropriate earth safety connections had a tendency to "arc" and "spark" - creating a trail of "noise pulses" with each firing. And as with the vehicles, the arcing and sparking just happened to have a natural centre frequency in the 40 - 50 MHz spectrum space.

And then there was the interference situation - interference from *other* transmitters in the same 40 - 50 MHz region, but far removed from your area. Scientists in the mid 1930s believed that once you moved out of the region below 30 megacycles, you could expect only "line of sight" transmission. Below 30 megacycles, the so-called "short-wave spectrum" (3 to 30 MHz), signals routinely "bounce" or reflect from several layers in the ionosphere. Starting at around 60 miles "up" and extending to as high as 400 miles "up," the earth is blanketed by something called "free ions" - basically, a very thin atmosphere. But the ionosphere is like a gigantic surfing envelope that rises and falls, collects and then disappears when struck by the sun's energy particles. Nobody bothered to advise the "sun" to leave the radio frequencies above 30 megacycles alone.

At certain times of the year, and certain times of the day, transmitters operating in the 40 to 50 megacycle region were "bouncing" off the ionosphere to distant points. This was an unexpected and serious problem - so much so that at the request of the British government an FM radio station located in Chicago, Illinois, the USA was asked to delay the start of their programming by several hours each day because TV viewers in London were getting so much interference from the station's broadcasts they could not watch BBC television! The FM radio station obliged, and then resolved the problem by moving to a new frequency near 100 MHz, far away from the BBC's 45 MHz region TV transmitter. Of course the problem worked in both directions - the US government in 1948 cancelled TV channel 1 for use by television realising it had made a mistake allocating the 44-50 MHz region to television in the first place. New Zealand, today, still uses channel 1 (44-51 MHz) and there are 25 licensed transmitters throughout the country on this frequency. Australia has been attempting to shift TV transmitters off of channel 0 (45-52 MHz) for nearly a decade but transmitters continue there at several locations (Toowoomba, Qld; Wagga Wagga, NSW and Tamworth, NSW are the three most powerful ones still on channel 0 - there are 3 others as well). As you might suspect or already know, those long distance ionosphere aided reception problems have plagued New Zealand reception of

LET THE SHOW



BEGIN!

SMALL DISH -TYPICALLY 90CM- INDIAN RECEPTION IS NOW AVAILABLE FOR AUSTRALIA AND NEW ZEALAND!

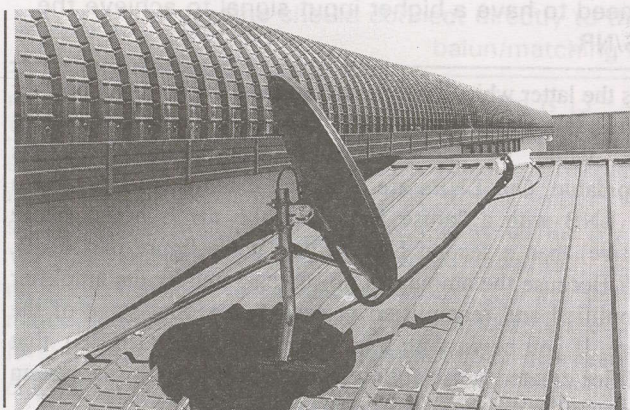

Two channels!

Gujari Channel (Gujarati language)

Lashkara Channel (Punjabi language)

Two additional channels - soon!

24 hour service!

If you sell or install home dish systems - (NZ only) we want to talk with you!

ATV supplies the service through the specially reconfigured Optus B3 Aurora platform.

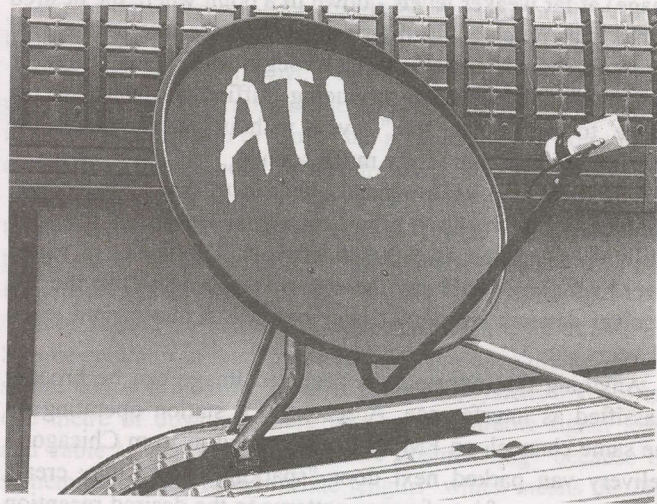

Asian TV Pty Ltd (ATV) is the two-channel bouquet broadcaster.

We manage the yearly subscriptions and the Irdeto CA service using Optus approved Irdeto compatible IRDs.

Turn-on your Indian clients to ATV service today!

-For Australian Installations-

Asian TV Pty Ltd.

1300-302-245

Fax (+) 61-2-9279-3896

-For New Zealand Installations-

Satcom (NZ) Limited.

09-238-3083 / 025-938-313

<http://www.satcom.co.nz>

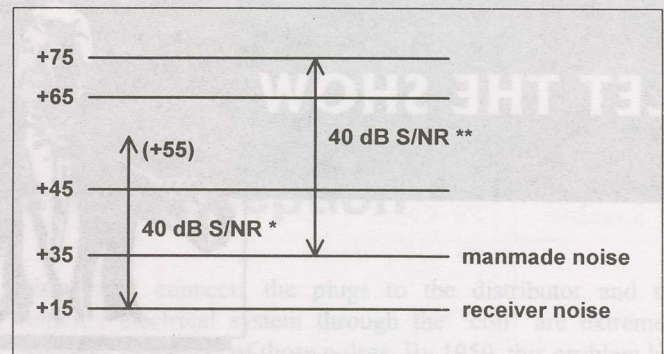
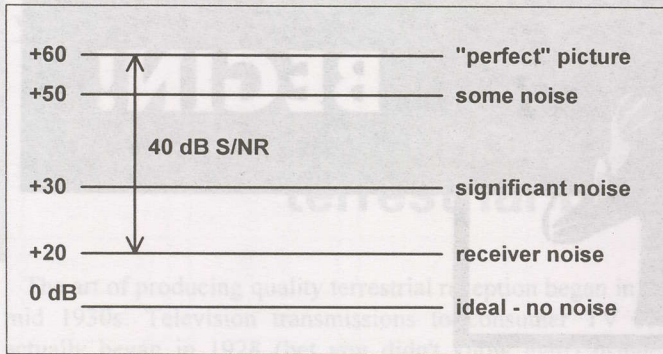

1939 calculation of signal to noise ratio (left) began with assumption that internally generated receiver noise (20 dBuV) was "threshold" of system noise. 2000 calculation (right) begins with 15 dBuV threshold in very quiet receiving location (*) with no manmade noise - if there is noise present through aerial pickup (**), the "threshold" begins higher up the dBuV scale resulting in a need to have a higher input signal to achieve the desired 40 dB S/NR.

channel 1 stations for as long as there has been television in the country. Trans-Tasman reception between Australia and New Zealand is a particular problem but even within New Zealand there are more than 50 days a year when TV signals bounce between the two islands.

Signal to noise, signal to interference

The terrestrial TV transmission format is relatively unforgiving of interference. Objectionable interference (capable of making a picture unwatchable) occurs when the desired signal is less than 20 dB stronger than the interference. The interference is recognisable (as imperfections on the image) at far weaker levels - down to a point where the desired signal is as much as 40 dB stronger than the interference. If the terrestrial TV signal is weak to begin with (because the TV antenna is incapable of producing sufficient signal for the image to be "noise free" even without interference), the interference mars the image much sooner.

A 1939 written RCA manual intended to assist TV receiver installers recommends a minimum signal level of 1 mv (one millivolt, the same as 1,000 microvolts - today on a signal level metre we would say the signal is +60 dBuV) to the TV receiver antenna terminals. They had it just about right, even 61 years ago.

Anything that corrupts the received image can be broadly classified as interference. A second TV station operating on the same channel, an FM station bouncing in from Chicago, a delivery van parked next door "sparking" away may create different types of interference patterns to the desired reception - each is interference. RCA in 1939 assumed none of these were present when they recommended 60 dBuV of antenna delivered signal to the TV set.

Inside of the TV set there are circuits and (today) transistor or IC devices that amplify the relatively weak off-air terrestrial TV signal. Just as our satellite receiving systems have signal amplifiers (the LNB is the first one - typically 60 dB of gain there, followed by more gain circuits inside of the satellite receiver - typically an additional 60 dB or more), the TV set has to boost the signal before it can be converted into picture and sound. An amplifier stage has two relevant characteristics of interest here:

- 1) The amount of gain it creates (measured in decibels or dBs)
- 2) The "noise figure" of the amplifier

It is the latter which is important to us initially. *Any* amplifier device has a noise generator built into the system. Creating noise, while at the same time amplifying signal, is unavoidable. Our LNBs are a perfect example of this. A Ku band LNB with a "noise factor" of 0.6 dB is better (more sensitive) than a second LNB with a noise figure of 1.0 dB. Why? Because the amount of noise generated by the amplifier is amplified and reamplified in each succeeding stage of the system. If you begin with a higher noise figure (1.0 dB), that amplifier created noise follows the signal through the system to the satellite receiver.

RCA's 1939 technology began with the "noise floor" of the receiver as a limiting factor in reception. In other words, how much noise did the receiver's amplifier stages generate while processing the TV signal? Reverting back to the dB scale - if the television receiver is recommended to have 60 dB(uV) of signal for a "noise free" picture, what was RCA saying about the receiver proper? First, that it had to have some significant difference between the noise the receiver created and the signal that it amplified. This "ratio" of the desired signal to the noise of the system is abbreviated by engineers as the S/NR or signal to noise *ratio*. The pivotal word here is *ratio*.

If 60 dB is an impairment free picture, at what point does the noise itself start? The answer is not 0 dB(uV) because 0 dBuV would be no noise at all.

Every amplifier creates noise - the question is only "how much noise?". Low noise amplifiers (as in LNB - "low noise block" [downconverter]) have evolved over decades of tiny improvements. In the 1939 TRT12 television set from RCA, the gain or amplifier stages inside the TV set created a "noise floor" of around 20 dBuV. Disconnect the TV aerial from the TV set, hook up test equipment and measure the amount of noise present in the system with no signal. The answer was 20 dBuV or around 10 microvolts. Thus, if the TV set creates 20 dBuV of noise, and it takes a ratio of 40 dB S/NR to produce a noise free picture, we need 40 dB more signal than we have noise.

The essence of the 1939 RCA text has not changed. Terrestrial TV reception still requires 40 dB more signal than noise, and 40 dB more desired signal than "interference" to be blemish free. The only change from 1939 is the actual (measured) "noise floor" of modern TV receivers. Today, the noise floor of a quality TV set is in the region of 15 dBuV (6 microvolts of noise). This means that if 15 dBuV is the receiver "noise floor" and you need a 40 dB signal to noise



Signal "lost" between aerial terminals and input to masthead amplifier cannot be recovered - it is gone forever. Additionally, random lengths of coaxial line connecting aerial output (through balun or matching transformer) to input of masthead are naturally "resonant" on one or more TV channel frequencies, creating "system mismatch" which will adversely affect the performance of the masthead amplifier. The masthead amp should connect directly to the aerial output terminals, through a suitable balun/matching transformer when required.

ratio (S/NR) then the minimum signal required is $15 + 40 = 55$ dBuV. You can prove these numbers to yourself by taking a signal level meter and TV set connected to a terrestrial TV antenna and attenuating the signal to the meter while simultaneously watching the picture quality on the TV set. With no external (antenna - masthead) amplifier, as the measured signal hovers around 55 dBuV you will begin to notice "graininess" (noise) on the screen. Reduce the signal level lower in level and the "grain" turns into on-screen snow.

Adding a masthead amplifier?

What you have just read contains one immutable law of physics. It is not *how much* signal you have that determines the quality of the TV picture - it is the *ratio* between the signal and all forms of interference. For this discussion, we have to include "receiver generated noise" as a form of interference.

There is one more thing to consider. That every amplifier creates noise; *every amplifier*. But some create more noise than others. Which leads us to another immutable law of physics:

The noise factor of a receiving system is most affected by the noise created within the *first* amplifier stage of the system. In other words - if you have a very low noise amplifier as the first amplifier, the amount of noise in the entire system is reduced by the noise factor of that first amplifier.

VHF and UHF (TV) masthead amplifiers are rated by their gain (how many dB?) and by their noise factor (number of dB of noise figure). Having lots of gain is a detriment, especially if the noise factor of the masthead is high. Let's go back two steps to 1939.

After the first TV stations in the world were built in the 40-50 MHz region in the mid 1930s, it was discovered that manmade noise from vehicle engines, power lines and a host of other appliances was at its worst in - the 40-50 MHz region. They could not have selected a worst spot for TV! Remember that the goal is to maximise the S/NR which requires getting as much signal as possible from the air (the "S" in S/NR) and as little noise as practical (the "N" in S/NR).

Tests conducted by the BBC, RCA and others revealed that a 4 cylinder vehicle parked 100 metres from a 45 MHz TV antenna produced on average 40 dBuV of "noise" signal. That meant the TV signal, to be impairment free, had to be not 60 dBuV from the antenna but 80 dBuV to attain the desired 40 dB S/NR ($40 \text{ dBuV} + 40 = 80 \text{ dBuV}$).

What about the 20 dBuV noise floor of the TV receiver? Noise does not as a rule "add together"; a 20 dBuV inside-of-receiver noise floor coupled with a 40 dBuV set of ignition spikes from a truck does not equal 60 dBuV ($20 + 40$). In this example, the truck's 40 dBuV ignition noise covers up the receiver's internal 20 dBuV noise floor.

A high percentage of masthead amplifiers are incorrectly installed after being incorrectly source selected. The challenges include the following:

- 1) The masthead amplifier should mount directly at the downline terminals of the aerial.
- 2) The noise figure of the masthead amp is more important than the gain.
- 3) When trying to improve a weak signal, the installer should never confuse the purpose of the masthead amp - it is not being installed to allow you to "split" the antenna's signal so as to be able to feed two or more TV sets from the same aerial.
- 4) You can only improve the S/NR of the TV set connected to the system by reducing the overall "system noise floor" and the "system" includes the aerial, the masthead amplifier if one is used, and the TV set.

Why should the masthead mount at the antenna terminals? Simple enough - at the aerial terminals you have the *maximum* signal you will measure for that particular system. Even after one metre of downline there will be measurable signal loss, and cable to masthead "impedance mismatching" because of something called "resonant line lengths" which means the "S" in S/NR is reduced. After 2 metres, even more "S" loss. The myth is that you can "restore" the lost "S" by sticking a masthead amp in the line half way down to the TV set. That is incorrect. You can restore the signal voltage (how much signal you can measure) but the S/NR cannot be restored to its original best as measured directly at the antenna terminals.

Why is that?

Think of "S" as the contents of a litre of water. It is filled up to the top of the container at the antenna terminals; 5 metres of line towards the TV set, the attenuation of the downline has reduced the water in the container and it is now 3/4 full. No - you cannot transport signals through downline without having "S" loss.

So you decide to install a pump on the line to boost the strength of the water pressure at the bottom. The pump is our masthead amplifier. With the pump/masthead 5 metres down the downline towards the TV set, we switch on the pump and

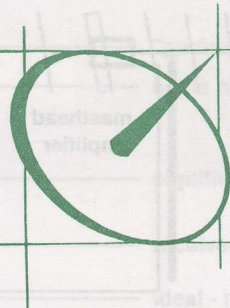

SATECH

Satellite Communication Technology Pty. Ltd.



HERE IT IS - the **ONE** IRD you need for your FTA customers



as reported in SatFACTS December 1999

There are no negatives about the SRT 4600 that we would bring out in a month of testing. No glitches, no "turn it off for a reset," no annoying software routine miscues. Equally at home on C or Ku, any format video, PowerVu or "real" DVB as long as the service is FTA.

The STRONG SRT 4600 - the **ONE** IRD
that is consumer and installer friendly!

 Sole distributor for Phoenix Worldwide 

SATECH

Satellite Communication Technology Pty. Ltd.

Head Office: 6/477 Warrigal Road Moorabbin East Victoria Australia 3189 Ph: 613 9553 3399 Fax: 613 9553 3393

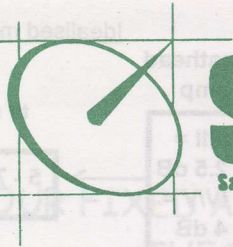

SATECH

Satellite Communication Technology Pty. Ltd.

SATECH Distributors for the full range of CALAMP

CABLES

Times Fibre & Comscope

huge range of RG6 & RG11

- dual
- quad
- flooded
- messengered

also 5 core tracking system cable
(available by reel or per meter)

RG 6
dual
\$99



- CALAMP C band 25k voltage switching LNBF
- CALAMP KU band 1db prime focus voltage switching LNBF
- CALAMP KU band 1 db off-set voltage switching LNBF
- CALAMP C band digi-ready phase locked loop 25k LNB
- CALAMP C band mini-mag 17k LNB
- CALAMP C band mini-mag digi extended 20k LNB
- CALAMP KU band 0.8 db LNB
- CALAMP KU band 1db high stability LNB
- CALAMP C band extended professional II low phase 20k
- CALAMP MMDS integrated antenna

also available cyclone 2.3m mesh dish

easy to install

reliable

cost effective

CHECK OUT OUR WEB PAGE ON

www.satech.com.au or email to us at satellite@satech.com.au

One Stop Shop

- receivers
- dishes
- cables
- fly leads
- wallplates
- feedhorns
- Lnbs
- tools
- tape
- poles
- dectite

SATECH
Distributors
for the
full range of
PARACLIPSE

Ring us for the latest products from Strong Technologies

- Dishes 65 cm, 90 cm and 2 - 3 m
- LNB's
- Digital Receiver

DISHES

SATECH your no.1 paraclipse distributor for the complete paraclipse range

Paraclipse Dishes

- exceptional strength and wind resistance
- accurate reception

when
quality
counts

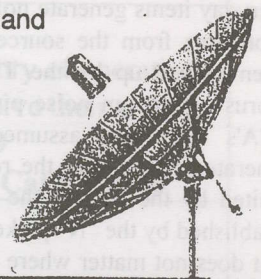

Paraclipse
HIGH PERFORMANCE ANTENNAS

All products available through the following SATECH distributors:

- Satech (Victoria) Tel: (03) 9553 3399
- South Satellite (South Australia) Tel: (08) 8377 0955
- Network Satellite Services (NSW) Tel: (02) 9687 9903
- Norsat (Western Australia) Tel: (08) 9451 8300
- Mathews Electronic Service Services (New Zealand) Tel: (09) 634 5130, outside Auckland 0800-777 376

measure a higher water pressure/signal voltage than without the pump. But if we place a new container at the bottom of the line, after we have pumped the top container dry, we will not have the original one litre - only the 3/4 litre remaining where we installed the pump/masthead.

Put another way - any signal lost in the downline between the aerial and the input to the masthead amplifier is lost - forever. It is not recoverable. *Aaah-ha!* exclaims you - you have seen "better pictures" with a masthead than without. *"This is proof the masthead creates more signal!"*

More signal *voltage* - yes. More "S" - yes. A better S/NR? Only in very unusual circumstances. And it all relates to that device at the end of the line - the TV set. Remember that the system noise floor is determined by the noise factor of the *first* amplifier stage. If the TV set's tuner is the first electronic amplification of the TV signal, then the noise factor of the tuner is the determining noise figure for the system. If, however, we place a masthead amplifier in front of the tuner - up at the antenna - then the gain (amplifier) in the masthead becomes the determining noise figure for the system.

A typical TV tuner in a modern TV set has a noise figure in the region of 5 dB for bands I and III (VHF low band, VHF high band) and 7 dB at UHF (bands IV and V). Noise figure is the same in terrestrial TV set tuners as "noise figure" is in a C-band or Ku-band LNB. Lower is better. Usually.

Using modern transistors, a quality masthead amplifier will have a measured noise figure in the region of 2.5 dB at bands I and III, under 4 dB at bands IV and V. Those numbers are 2 to 3 dB better in performance than the TV set tuner. So using a masthead when the off-air signal is lower than required to create a S/NR of 40 dB is advisable. That assumes the masthead is installed right at the antenna terminals, of course, before the downline degrades the "S" in S/NR.

But there is another factor to consider - external noise. Manmade devices create tremendous amounts of "RF pollution" all around us. If radio signals were coloured pink, you would be dripping wet where you now sit. As the pioneer TV broadcasters discovered to their horror, several common forms of radio frequency interference (RFI in the trade) peak in intensity in the 40-50 MHz region. Frequencies lower have more noise, frequencies higher have less noise. But not "no noise."

Water pumps, electric fences, fluorescent lighting fixtures, any gasoline or diesel powered motor, personal computers, electric light controllers, power lines - hundreds of common, everyday items generate noise that radiates a few mm to a few kilometres from the source. Each of these noise generators, when picked up by the TV aerial, creates a dawn to dusk chorus of random noise pulses that add to the "N" in S/NR. RCA's 1939 tests assumed only the presence of "receiver generated noise." In the real world, the "N" is very seldom limited by the "N" of the receiver noise floor - rather, it is established by the "N" picked up by the TV aerial.

It does not matter where the "N" comes from - whether it is generated inside of the receiver, or externally. N is N without regard to source. And if the "N" is higher than the receiver's internally generated N, then the S/NR is affected adversely.

All of this comes to point when we consider the practical improvements we might *actually* realise with a masthead amplifier. If the noise figure on band I is 2 dB in the masthead,

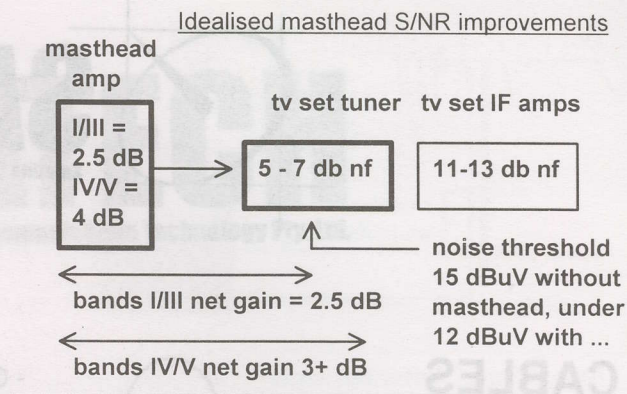

Practical effects of masthead in real world

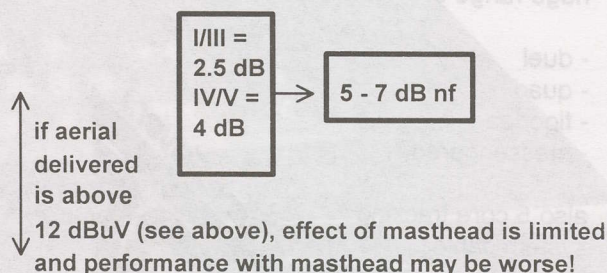

but the noise pollution is 20 dB, improving the TV set's tuner noise figure by 2.5 dB is not going to help the S/NR at all.

Noise pollution within band I is at its worst. Band III is a few dB better, bands IV and V are as much as 10 dB "better" (less noise from the same noise source). Therefore, masthead amplifiers that amplify both signal ("S") and external noise sources ("N") are least effective at band I, progressively more effective as the frequency increases. At the same time, the TV receiver's internal noise figure is increasing with frequency - so when the "N" of the external sources drops while the frequency increases, and the "N" inside the receiver simultaneously rises, we have far more success with mastheads at UHF bands IV and V than at bands I and III.

Synopsis

An off-air television signal that does not have a 40 dB signal to noise ratio is impaired. Either you need more signal, or less noise or both to attain "quality" television. "Noise" is anything that degrades the image on the screen, the sound in the speaker. It can originate inside of the TV set, or externally.

The TV signal is strongest at the TV aerial terminals - that is the location for a masthead amplifier if one is to be used. Any other location compromises the performance of the masthead and degrades the system results.

Masthead amplifiers can only improve the signal to noise ratio (S/NR) of the received signal when external noise is absent. A good quality masthead will *always* improve the noise factor of the TV set, but if the predominant noise in the system is coming from sources outside of the TV receiver, through the aerial, the masthead will be either ineffective or only partially effective. If the noise sources are intermittent (such as with many electric stock fences and power lines), the masthead may do wonders one hour and do nothing the next - as the noise source turns "on" and "off" to its own internal clock.

Next month

Determining *what* the noise/interference is, *where* it originates, and whether it can be corrected.

UPDATE YOUR FIXED ANALOG OR DIGITAL SYSTEM WITH THESE ACCESSORIES:

<p><u>Single Axis Positioner</u> Update your fixed satellite system with this positioner.</p>  <p>\$199 Cat # M1000</p>	<p><u>18 inch Actuator</u> Reed sensor, heavy duty actuator. Special price \$260. Order M1000 and M1510 together and pay only \$400 Both units come with 12 month warranty. SAVE \$60! Cat # M1510</p>	<p><u>24 inch Actuator</u> Reed sensor, heavy duty actuator. Special price \$280. Order M1000 and M1540 together and pay only \$420 Both units come with 12 month warranty. SAVE \$60! Cat # M1540</p>
<p><u>0/12v Coaxial Relay</u> Automatically switch between 2 C band dishes or a C and K band dish. Suits IRDs with 0/12V RCA outlet. \$49 Cat # P1700</p>	<p><u>Manual Coax Switch</u> Manually switch between 2 dishes and one receiver. Carries DC to the LNB, rated to 2000MHz. \$39 Cat # S2000</p>	
<p><u>2.4GHz video sender</u> Comprises a separate transmitter and receiver. Sends audio and video on 2.4GHz, and return RF link on UHF allows you to control the source using the original IR remote from any room in your house !! 4 channel system allows easy 2.4GHz channel changing in case of adjacent users. Introductory price just \$299 Cat # X1105</p>	<p><u>4 Way A/V Signal Switcher</u> Too many remotes in your house? Use this intelligent switcher to prioritize A/V sources. Input 1 has priority. If source to Input 1 is off, Inputs 2, 3, 4, assumes sequential priority. Detects and switches the active input to 2 parallel outputs suitable for driving video sender or monitor \$99 Cat # T1951</p>	
<p><u>Satmaster Lite for Windows 95/98</u> Use this 2 disk software to give pointing co-ordinates for all visible satellites from your location, calculate down-link budgets for digital and analog signals, make solar outage predictions, show rain attenuation etc etc. Has a huge multi-country database \$199 Cat # S 1101</p>	<p><u>Xanadu digital receiver</u> Fully featured digital receiver has inbuilt dish pointing calculator, signal strength monitor, transponder editing, SVHS, UHF and composite video outputs, selectable and secondary audio network, Manual PID entry, 1-45Msym capability for FTA broadcasts \$799 Cat # R3100</p>	
<p align="center"><u>The Practical Guide to Satellite TV</u> Second edition, printed mid 1999, has 122 pages of data, footprints, theory of operation and history of satellite TV. Find out how satellites work and how to receive their signals. Written in easy to understand language, not Swahili! \$39 Cat # B1030</p>		
<p align="center">AV-COMM PTY LTD (ACN: 002 174 478) P.O. Box 225 Balgowlah NSW 2093 Australia TEL: 612 9939 4377 FAX: 612 99394376 Web: http://www.avcomm.com.au Email: sales@avcomm.com.au You are welcome to join our E-mail Newsletter Service. Just send E-Mail to addme@avcomm.com.au.</p> <p align="center">* Prices do not include shipping and include Australian Sales Tax. (if applicable)</p>		

a technical and marketing
advisory

memo

to the membership from your
industry trade association

SPACE Pacific

Satellite
Programme
Access
Committee



A trade association for users, designers,
installers, sellers of private satellite-direct
systems in the Pacific Ocean & Asia Regions

Settling out of court

As we have previously reported, Victoria (state) law now defines any parabolic family dish larger than 1.2m as a "telecommunications facility installation" and then prescribes special bureaucratic - must follow - rules for dish installation. It matters not, according to the bureaucrats, that the same law catches 10 metre dishes installed for uplinks and point to point terrestrial microwave dishes mounted atop sizeable support structures. It is a sad example of being caught up in a Tuna net when you are a baby Dolphin.

Joseph Choukry, in suburban Melbourne, has been forced to move his 3m dish 600mm back from the front of his lot and 300mm down closer to the ground. "Forced" means he has been told that in order to avoid more bureaucratic entanglements in his life, he must change the location of the dish. If 600mm back and 300mm down seems like a small change to you, think again. The installer of his dish had very carefully found the least obtrusive dish location, at the lowest possible height above ground so that Joseph could still access InSat 2E and AsiaSat 2. These two satellites carry programming of ethnic interest to Joseph and that programming was why he bought the dish in the first place.

But, under the 1999 adopted Victorian rules, his dish was slightly too close to the street (and could be seen by a neighbour if the neighbour stood in just the right spot in his yard while contorting his body into an unnatural position) and by 300mm too high. Joseph Choukry spent, he reports, \$4,000 of his own money hiring an attorney to do battle with the Victorian bureaucrats. The bureaucrats were insisting he take the dish down, totally, since it required a permit.

His attorney in preparing a submission to the Hume City Council, wrote, "There are two basic issues in this appeal. The first is the legal issue as to whether a permit is needed at

all. The second is the merits issue as to whether, if a permit is needed, visual amenity aspects sufficiently weigh against the granting of a permit."

The dish was installed early in January (1999). Late in February, Joseph Choukry received a formal letter from the local authority threatening enforcement action if a Town Planning Permit was not filed. Choukry, not agreeing he required a permit, none the less responded to the Town office with an application for a permit. In mid-March, 2-1/2 months after the dish was originally installed, Victoria introduced Amendment S76 covering changes in the Planning Scheme for Telecommunications Facilities. Moving with the speed of a dying snail, the Planning authority denied his application for a (variance) permit on October 11. They authority also pointed out the dish did not require a permit after all.

End of story? No, merely chapter one.

On February 17, (2000) a "new" structure for the Home Planning Scheme got underway. Now rather than a simple permit, someone requesting a 3m dish at a private residence had to qualify under the cumbersome, complicated, complex and convoluted "Code of Practice for Telecommunications Facilities." The same new rules apply to cell phone sites, point to point microwave installations, radio or TV broadcast towers. In other words - the rules were built around big guys doing big things with big pocketbooks.

Because every parabolic dish larger than 1.2m is considered a part of a telecommunications facility, poor Joseph Choukry was now moved from amateur to professional. Under the Telecommunications Act, to be considered a professional his installation must:

- 1) Be a part of a "network"
- 2) Involve the service of a communications carrier
- 3) Be capable of transmitting

MEMBERSHIP IN SPACE

Membership in SPACE Pacific is open to any individual or firm involved in the "satellite-direct" world in the Pacific and Asia regions. There are four levels of membership covering "Individuals," the "Installer/Dealer," the "Cable/SMATV Operator," and the "Importer/Distributor/Programmer."

All levels receive periodic programme and equipment access updates from SPACE, significant discounts on goods and services from many member firms, and major discounts while attending the annual SPRCS (industry trade show) each year. Members also participate in policy creation forums, have correspondence training courses available and their support makes possible the TV show SPACE Pacific Report. To find out more, contact (fax) 64-9-406-1083 or use information request card, page 34, this issue of SatFACTS. Page space within SatFACTS is donated each month to the trade association without cost by the publisher.

Of course none of these apply. Never mind, at some deeply hidden level of Victorian government, a decision has been made; "Joseph Choukry and anyone else who thinks they can install a home satellite dish larger than 1.2m must comply with these rules."

In a presentation not delivered to the Hume City Council (we will explain why, shortly), his attorney wrote:

"*This dish is for domestic use only, receives only television programs, does not cause interference to television or radios, is set low to the ground and in the backyard in the only location suitable for this purpose, is in an urban situation competing with amenity intrusions (visual and aural) from the complaining neighbour and others, has been repainted from the standard black to an environmentally sensitive dark green, is hidden from the neighbours by the side fence and vegetation.*"

The neighbour filing the complaint apparently would settle for nothing less than total dish removal. Whether Choukry had a dog that once peed on the neighbour's flowers, or carried an ethnic grudge against people of Choukry's origin is unknown. Joseph Choukry did gather six other neighbour signatures on a petition urging the town to approve his dish - if a competent body was ever able to decide that such permission was mandatory.

"*It must be remembered that here we are dealing with an item associated with domestic use in an urban environment. It should not be considered in isolation against a mirage of a pristine background. It has been introduced into a domestic situation for a domestic purpose and ought to be considered as part of the 'give and take' which of necessity has to exist in our urban environment.*"

"*Urban life is all about achieving a balance and compromise between the rights and desires of a person and the*

rights and impacts on that person's neighbours, whether that be as, in this case, any visual impact of the satellite dish from the Applicant's property to the neighbour's property or vice-versa (for example, the air conditioning unit on the neighbour's roof and the aural impact of the neighbour's spa which is situated next to the boundary fence and adjacent through the fence to the Applicant's bedrooms). It all comes down to people having to be flexible in their dealings with their neighbours. Admittedly, some of the things introduced into a neighbour change the visual scene, but that does not make them any less part and parcel of a domestic situation. People living on the 'shadow' side of a hill (for example, Coonans Hill in Pascoe Valke South) have extremely high television antennas to catch the normal local domestic television transmitters. Simply because of their height and the fact they are visually apparent to anyone in the area does not make them any less a normal part of the domestic situation."

Those extracted, not filed words written on 21 February by Choukry's attorney had the potential to have won the case. But alas - Joseph Choukry, faced with ballooning legal bills and a Town planning department circling for a complete kill decided to accept a compromise. He agreed to drop the dish 300mm and set it back 600. As previously noted, *there went InSat 2E and As2.*

As long as the Victorian rules continue to include satellite dishes larger than 1.2m in their Telecommunications Facility spider web, this sort of situation will come up with increasing frequency. Installers in Victoria now believe the Victoria Department of Infrastructure will not voluntarily change their self-made-up definition of satellite dishes. What remains is to find an Australian agency that will intercede to get home satellite dishes back to a level playing field.

NEW ZINWELL DIGITAL RECEIVER

ZDX-9111 FTA
A\$360 + tax

ZDX-8111
FTA + CI
A\$460 + tax

Comstar
MESH DISH ANTENNAS

- MPEG-2 DVB, PowerVu, FTA
- ZDX-8111 also works on **Irdeto**, Nagravision, Cyptoworks, Conax
- Multi-SCART, RCA and Y/C Video Sockets
- CE and FCC approved
- High speed port (IEEE-1284, RS-232)
- CI TRDECK Module - A\$150 (available only to ZDX-8111 buyers)

DIRECT IMPORTER AND SUPPLIERS OF THE FOLLOWING:

Jonsa Dishes, MTI, Zinwell LNBs, SPACE TV "BOX", Benjamin Analogue

C & T SATELLITE SERVICES PTY. LTD. ACN086028882
Shop 7/17 Barrett St., Robertson, Qld. 4109, Brisbane
Australia tel ++61-7-3255-5211, fax ++61-7-3255-5126

C&T/C&T/C&T/C&T/C&T

The CABLE Connection

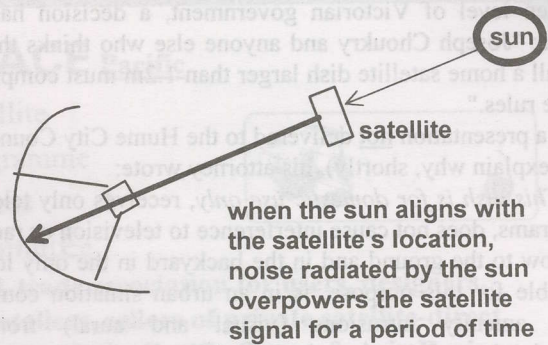
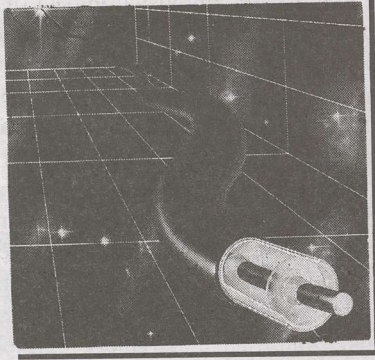

Sunspots and spiders

Twice each year the sun crosses above the equator in its trek towards our north and south poles. *In fact*, the sun does *not* move at all (except of course through space, dragging us with it) but our earth's 22+ degree tilt takes us into a twice annual period when the sun is directly above the equator. For a few fleeting seconds. Half of the year it spends "north" of the equator, the other half "south." In most countries, the year's four seasons are measured by that crossing or the extreme northern position (summer in North America) and the opposite - summer in New Zealand and Australia.

All of this has an impact on our satellite reception. At some point between early March and mid April, from any location you may happen to be at, the sun and the satellite belt above the equator align. That is, the sun falls directly behind the satellites we view.

Which is another way of saying that when our satellite dish points at a satellite, for a few minutes each day for approximately one week it will also be pointing directly at the sun. If you are using prime focus dishes, with the LNB and feed antenna located at the centre of the dish, you can judge the location of the sun by noticing where the shadow from the feed falls. When it falls dead centre on the dish, you are looking at not only the satellite but the sun as well.

Two categories of radiation come to us from the sun. Those that heat us (and provide light) and those that arrive at wavelengths longer or shorter than the visible light. It is the wavelengths that we cannot see which cause the satellite reception to disappear during those few minutes within the week the dish and the satellite and the sun align.

The sun is a gigantic (by our standards) generator of radio waves. Our dish, when pointing at the selected satellite and the sun simultaneously, sees not only the signal from the satellite but the radiation from the sun. The sun wins because it is more powerful than any satellite yet created by mankind - even allowing for the considerably greater distance to the sun (93 million miles give or take a few) than to the satellite (under 27,000 miles).

For a satellite due north (or south) of your location, the sun will fall behind the bird at 12 noon local time. For satellites east of due north or south, the alignment will occur prior to noon; for satellites to the west, after 12 o'clock.

Solar "noise" received by the dish when the sun falls behind the satellite averages 6 to 10 dB stronger than the strongest satellite. If you have a very big dish, the sun's noise is still stronger than the satellite because the sun is - like the satellite - a "point source" in the sky. More gain in the dish, more signal from *both* sources. You cannot escape the effects of sun noise with a larger dish, although you can reduce the number of days during which the effects are noticed.

Solar noise is stronger at 4 GHz than at 12 GHz (C versus Ku bands) but still noticeable even at Ku. The smaller the dish, the greater the effects because the beamwidth (the area in the sky seen by the dish) gets larger with smaller dishes. A 30m dish (you can wish for one) might notice the effects of the solar noise for a few minutes on a *single day* each March and September (the two periods when the sun is "above" the equatorial region). A 65 cm dish sees the sun's noise for a week to ten days - or longer because the beamwidth covers a larger segment of the sky. On a 30m dish, the sun needs to be *precisely* behind the satellite to be noticed. On a 65cm dish, the noise can be seen when the sun is still a couple of degrees either side of the satellite. "Either side" refers to up and down (above or below) the satellite as well as right and left (east and west).

As the sun *moves* across the sky (which of course it does not do - what we observe is our earth rotating on its own axis while the sun is for this purpose stationary in the sky), the solar noise begins on an analogue signal as sparklies. Over a matter of minutes the sparklies become more intense, and then the picture disappears into the noise received from the sun. Think of this as a miniature eclipse - the sun "covers" part of the dish, then all of the dish, and then recedes to cover less and less until it is gone.

At the peak of the sun's alignment, the solar noise signal is variously up to 10 dB stronger than the strongest satellite in the sky.

The sun has something known as the 11 year "sunspot cycle." On the solar surface, fierce eruptions occur - called sunspots. With an appropriate filter on a very small telescope, projecting the solar surface onto a piece of shaded board, these "spots" appear as dark areas against the sun's otherwise fiery surface. The quantity of sunspots peaks roughly every 11 years, and 2000-2001 is a predicted peak period for the current solar cycle (called #23 because this is the twenty-third such cycle recorded by human scientists). Sunspots are notoriously noisy. They generate far more noise than the normal solar surface we see. When there are more sunspots, there is more solar noise. For *this* March and *this* September, the strength of the solar noise we observe will be more acute than any year since 1989-1990.

Sunspots are also massive disrupters of earth communications. Without warning they "erupt" like earth volcanoes spewing out massive amounts of raw energy. These eruptions upset our earth's magnetics, creating aurora displays that can be actually seen in the southern sky into central South Island (New Zealand) and along the southern coast of Australia. There is more "energy" in a single sunspot than all of the power generators on earth create in an earth-year. Fortunately for you and me, a minuscule fraction of that

energy ends up colliding with the earth's magnetosphere. That's because we are 93 million miles from the eruption. How big is it? Think of Hiroshima multiplied by a trillion times.

During the period 2000 to 2003, just following the peak of the current solar cycle, will be the most likely period for sunspots to spew out earth disruptive radiation. Events in 1989, 1992 were powerful enough to literally burn out power grids (long distance high voltage lines) in Quebec, Scandinavia and South Island (New Zealand). The same disruptions knocked out satellites - deader than a cold mackerel. The most vulnerable period for the earth's satellites are around the equinox periods - March and September.

Modern satellites attempt to protect themselves with a "hardening" system - sticking delicate electronics inside of electrically isolated lead shielded compartments. Sometimes it works, sometimes it does not. If you hear on CNN that a massive solar "electrical storm" is expected, and your favourite satellite suddenly goes bonkers, chances are it was struck by the disruptive solar radiation. It will happen again just as it has happened in the past.

Solar noise outages are not the result of a "solar storm." Only the intensity of the solar noise varies during a sunspot eruption and the odds that extremely intense radiation will arrive at your dish within those few minutes when your dish is pointed at the sun behind the satellite is a million to one. Or more. If it should happen, you can kiss good bye to your LNB and perhaps your receiver.

When the sun and the satellite do align, the visible "heat" energy from the sun is focused along with the invisible noise radiation at your dish focal point. An improperly painted dish (not protected with light diffusing paint) will collect and reflect some of this energy back to the feed. An example of

what can happen appeared on p. 29 for SatFACTS December - the black coloured plastic LNBF feed cover simply melted from the focused heat. We have seen 6m size unpainted dishes that were allowed to point at the sun (pretty stupid, really) actually turn the feed antenna and LNB into molten metal. The coax connecting to the feed system simply disappeared in a poof of smoke. Fooling around with a mother nature is not always pleasant.

Spiders? Well, part of our life cycle is the annual pilgrimage that creepy - crawly creatures make towards hibernation. Spiders, in particular, followed closely by wasps, head for protective shelter around late February - early March (south of the equator - late August, early September in the north). An open feed on a satellite dish is "Disneyland" for spiders and wasps. They crawl inside the open mouth, set up housekeeping and prepare for the onslaught of winter. A spider a few mm across, building a nest inside the throat of a feed, will shut down totally reception for the dish. Spiders, wasps build shelters using other dead bugs they have captured and hauled inside the protected feed. This seemingly innocent layer of matter stops microwave signals dead in their tracks.

Even a feed with a protective cover can be home for spiders - they build on top of the protective cover in layers and strangely are attracted to the plastic covers. If the cover sits inside the feed, with a slight recession, that mm deep gap is all they need to cause damage to your satellite system reception.

Spiders can usually be knocked out with a broom, wasps are more territorial and physically removing one attempt at cone building may only anger the creatures such that a hour or two later they are back at it in the exact same spot. Reception down? *Check your feed!*

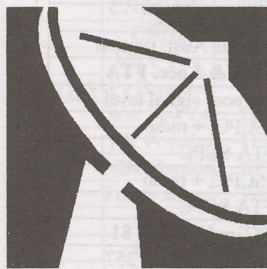

MELBOURNE SATELLITES P/L

ACN 065 270 733

Established 1992

Direct importers and suppliers of the following world renown products.

KTI
ORBITRON
PATRIOT
JONSA
ANDREW

ECHOSTAR
SCIENTIFIC ATLANTA
NOKIA
IKUSI
DX

GARDINER
CALIFORNIA AMPLIFIER
MTI
CHAPARRAL
ADL

Full range of cables, splitters and connectors.

Phone, fax or write for our 1999 Product SATalogue.

Sales/Warehouse - 84 Bayfield Road, Bayswater Victoria
Construction Services - 13 Ellum Avenue, Bayswater Victoria
Postal Address - PO Box 901, Bayswater 3153 Victoria Australia

Phone: (03) 9738 0888
Fax: (03) 9729 8276

User Friendly Site!

www.melbournesatellites.com.au

e-mail: sales@melbournesatellites.com.au

SatFACTS Pacific/Asian MPEG-2 Digital Watch: 15 March 2000

Bird	Service	RF/IF &Polarity	# Program Channels	FEC	Msym
I703/57E	Sky News	4143/1007R	1	3/4	5(.632)
	CNBC	4018/1132L	1	3/4	6(.000)
I704/66E	TV5	4055/1095R	4	3/4	27(.500)
	Sky News +	3805/1345R	4	3/4	22(.520)
PAS4/68.5E	Nickelodeon+	4147/1003H	1 reported	1/2	24(.000)
	BBC	3743/1407H	5	3/4	21(.800)
	CCTV	3716/1434I	up to 6	3/4	19(.850)
Ap2/76E	Hmark/Kermit	3720/1430H	4	5/6	29(.270)
	Channel "I"	3823/1327V	1	3/4	3(.570)
	TVB8 +	3849/1301H	4	3/4	13(.238)
Them3/78.5E	AXN	3920/1230H	up to 8	7/8	28(.340)
	ITC+	3520/1630H	up to 6+	2/3	26(.661)
	MRTV	3666/1484H	1	2/3	4(.442)
	Mahar/DD1	3600/1550H	up to 8	3/4	26(.661)
	PTV2	3420/1730V	1	3/4	3(.366)
	TV Maldives	3412/1738V	1	1/2	6(.312)
ST1/88E	Thai Global+	3425/1725V	up to 7?	2/3	27(.500)
	Taiwan Bqt	3509/1641H	13	3/4	23(.450)
MeSt 1/91.5E	Malay. TV3	4147/1004H	1	3/4	7(.030)
As2/100.5E	Euro Bouquet	4000/1150H	5TV, 19r	3/4	28(.125)
	Reuters	3909/1241H	1	3/4	5(.632)
	Hubei/HBTv	3854/1296H	1	3/4	4(.418)
	Hunan/SRTC	3847/1303H	1	3/4	4(.418)
	Guan/GDTV	3840/1310H	1	3/4	4(.418)
	Inn. Mongolia	3828/1322H	2	3/4	8(.397)
	APTn A-O	3799/1351H	1	3/4	5(.631)
	WTN Jer/Lon	3790/1360H	1	3/4	5(.631)
	Reuters/Sing.	3775/1375H	1	3/4	5(.631)
	WorldNet/US	3764/1386H	1 + 20 radio	3/4	6(.100)
	Liaonin/Svc2	3734/1416H	1	3/4	4(.418)
	Jiangx/JXTV	3727/1423H	1	3/4	4(.418)
	Fujian/SETV	3720/1430H	1	3/4	4(.418)
	Hubei TV	3713/1437H	1	3/4	4(.418)
	Henan/Main	3706/1444H	1	3/4	4(.418)
	As2/100.5E	Korea feeds	4090/1060V	1	3/4
	TVSN	4033/1117V	1	3/4	4(.298)
	Sky Racing	4020/1130V	up to 3TV	1/2	18(.000)
	EMTV	4006/1144V	1TV, 2 radio	3/4	5(.632)
	Jilin Sat TV	3875/1275V	1	3/4	4(.418)
	HeiLongJian	3834/1316V	1	3/4	4(.418)
	JSTV	3827/1323V	1	3/4	4(.418)
	Anhui TV	3820/1330V	1	3/4	4(.418)
	ShaanxiQQQ	3813/1337V	1	3/4	4(.418)
	Guan/GXTV	3806/1344V	1	3/4	4(.418)
	Fashion TV	3796/1354V	1	3/4	2(.533)
	MSTV	3791/1359V	1	3/4	4(.340)
	Feeds	3785/1365V	1	3/4	5(.632)
	Myawady TV	3766/1384V	1	7/8	5(.080)
	Saudi TV1	3660/1490V	1 (?)	3/4	27(.500)
As3S/105.5E	Arirang TV	3755/1395V	1	7/8	4(.418)
	Now TV	3760/1390Hz	5	7/8	25(.000)
	Star TV	3780/1370V	17(+TV)	3/4	28(.100)
	Star TV	3860/1290V	14(+TV)	3/4	27(.500)
	Star TV	3880/1270H	12(+TV)	7/8	26(.850)
	CNNI	3960/1190H	4(+TV)	3/4	26(.000)
	Star TV	4000/1150H	7(+TV)	7/8	26(.850)
	Zee Bouquet	4020/1140Vt	4+TV	3/4	27(.000)
Cak1/107.5E	Indovision (S-band)	2.536, 2.566, 2.596, 2.626	33(+TV)	7/8	20(.000)
Sinosat/110E	CCTV2	3889/1261Hz	1	3/4	3(.000)
C2M/113E	TPI	4185/965V	1	3/4	6(.700)
	Indosiar	4074/1076V	1	3/4	6(.500)
	Anteve	4055/1095V	1	3/4	6(.510)
	Space TV	4000/1150H	11TV, radio	3/4	26(.666)
	C Net Taiwan	3760/1390H	11TV, radio	3/4	26(.666)
	RCTI	3755/1395V	1	3/4	8(.000)
	Yong Hsiang	3622/1528H	1	3/4	5(.528)
	JcSAT3/128E	Miracle Net	3990/1160V	3 up to 6	5/6
	Asian bouquet	3960/1190V	up to 8	7/8	30(.000)

Receivers and Errata
NDS encrypted, often FTA
Feeds - typically FTA (SCPC)
FTA
Sky News 24 hr, sport, feeds; some FTA
Status unknown - was testing FTA
FTA; 2 audio channels
FTA
PowVu, typ. CA
Tests, FTA
PowVu, CA
Tests, promos, some FTA
also try Msym 13.330, FEC 3/4
FTA; difficult to load
FTA (has included Indian, Egypt)
FTA, new service, testing
FTA (reaches SE Australia)
FTA
MCPC, sometimes FTA, 2 adult chs
tests, possibly permanent, FTA
FTA (TV5 teletext)
FTA, occasional feeds
FTA SCPC, teletext
FTA SCPC, teletext
FTA SCPC, radio APID 81
FTA: #1 Chinese, #2 Mangolian
FTA SCPC (news feeds)
Mostly CA; some FTA
FTA & CA
FTA; up to 20 radio channels
FTA SCPC, radio APID 256
FTA SCPC, teletext, radio APID 81
FTA SCPC, + radio APID 80
FTA SCPC, radio APID 80
FTA SCPC, + radio
FTA SCPC/MCPC
FTA, not same as Aust. version
(Irdeto) CA; 1 & 3 occ. FTA
PowVu CA; poor signal level
FTA SCPC, + radio
FTA SCPC
FTA SCPC, + radio
FTA SCPC
FTA SCPC, radio APID 81
FTA SCPC, radio APID 257
FTA SCPC, now easy to load
FTA SCPC
FTA & CA, feeds
FTA SCPC - difficult to load
FTA MCPC + BBC World Radio
FTA SCPC; very strong signal
Tests, promotional material, one FTA
NDS CA (Pace DVS211, Zenith)
NDS CA (Pace DVS211, Zenith)
NDS CA (Pace DVS211, Zenith)
PowVu CA; some FTA feed channels
NDS CA (Pace DVS211, Zenith)
Testing, service on/off; also 3700/1450V
NDS CA using RCA/Thomson, Pace IRDs; improved reliability since June
FTA SCPC, difficult to load
FTA SCPC; may be test
May only be test - not reliable
FTA SCPC; may be test
CA, sometimes FTA
CA, subs available -10 radio FTA
FTA SCPC; may be test
Test, FTA SCPC
PowVu; TBN #3 FTA, some CA
CA and FTA, Japan, Taiwan, China

Bird	Service	RF/IF & Polarity	# Program Channels	FEC	Msym
L AP1/130	THT+NTV	3675/1475L	2 + 2 radio	3/4	12(.000)
Ap1A/134	Gansu TV	3769/1381V	1	1/2	6(.930)
Ap1/138	Reuters	3742/1408V	1	3/4	5(.632)
	Viacom	3860/1290V	up to 6	3/4	30(.000)
Op B3/156	Mediasat	12.336V	7TV, ra, Internet	2/3	30(.000)
	Aurora	12.407V		2/3	30(.000)
	Aurora	12.532V	now NZ coverage	2/3	30(.000)
	Aurora	12.595V		3/4	30(.000)
	Aurora	12.720V		3/4	30(.000)
	Austar/tests	12.376H		3/4	29(.473)
	Austar/Foxtl	12.438H		3/4	29(.473)
	Austar/Foxtl	12.564H		3/4	29(.473)
	Austar/Foxtl	12.626H		3/4	29(.473)
	Austar/Foxtl	12.688H		3/4	29(.473)
Op B1/160	ABC NT fd	12.256V	1TV, 3 radio	3/4	5(.026)
	Central 7	12.354H	1TV	3/4	3(.688)
	Imparja TV	12.367H	1TV, 3 radio	3/4	5(.424)
	Sky NZ	12.391/418V		3/4	22(.500)
	Sky NZ	12.518/546V		3/4	22(.500)
	Sky NZ	12.643/671V		3/4	22(.500)
	Imparja fd.	12.367H	1	3/4	5(.424)
PAS8/166	Pacific Time	12.286V	10TV	3/4	26(.470)
	ABCInterch	12.312H	1	3/4	6(.978)
	ABCInterch	12.321H	1	3/4	6(.978)
	ABCInterch	12.330H	1	3/4	6(.978)
	TARBS	12.526H	12+ TV	3/4	28(.067)
	Tests	12.606H	12+ TV	3/4	28(.067)
	Boomerang	12.725H	5 TV	7/8	25(.728)
	NHK Joho	4065/1085H	5TV, 1 radio	3/4	26(.470)
	ESPN USA	4020/1130H	7+TV, data	7/8	26(.470)
	DiscoveryTest	3980/1170H	8 typ.	3/4	27(.690)
	CalBqt/Pas8	3940/1210H	up to 5TV	7/8	27(.690)
	CNBC HK	3900/1250H	up to 7TV	7/8	25(.728)
	CNNI	3780/1370H	3, up to 5 TV	3/4	25(.000)
	MTV Test	3740/1410H	4	2/3	27(.500)
PAS2/169	Pv Bouquet	12.290V	2+ TV, radio	2/3	27(.500)
	WA PowVu	12.637(.5)V	4TV, 8 radio	1/2	18(.500)
	HK PowVu	4148/1002V	up to 8	2/3	24(.430)
	NBCHonKn	4093/1057V	5, up to 7	3/4	29(.473)
	Fox Bouquet	3989/1161V	8TV/data	7/8	26(.470)
	Feeds	3942/1208V	1 or 2	2/3	7(.497)
	Feeds	3929/1121V	1	3/4	6(.618)
	Feeds	3898/1252V	1	2/3	12(.000)
	Middle East	3778/1372V	4	3/4	13(.331)
	Service 1	3761/1389V	1	3/4	6(.620)
	CCTV Pv	3716/1434V	5 typical	3/4	19(.850)
	Feeds	4138/1012H	1	3/4	6(.620)
	Napa card	4040/1110H	1	3/4	5(.043)
	7thDyAdv	4034/1116H	1TV, 14 audio?	3/4	6(.620)
	CNNI HK	3996/1154H	1	3/4	9(.998)
	Feeds	3867/1183H	1	2/3	6(.618)
	7thDyAdv	3957/1193H	1TV, 14 audio	3/4	7(.000)
	Feeds	3939/1211H	2 (typ NTSC)	2/3	6(.620)/7(.498)
	Cal PowVu	3901/1249H	up to 8	3/4	30(.800)
	Disney	3804/1346H	3	5/6	21(.093)
	Discvry Sng	3776/1374H	8 typ	3/4	21(.093)
	Satcom 1-6	3743/1407H	up to 5	7/8	19(.465)
I702/177E	AFRTS	4177/973LHC	8TV, 12+ rad	3/4	26(.694)
	ThaiBouquet	12.650H	up to 3 TV	1/2	17(.800)
I701/180E	Canal+ Sat	11.610H	16TV, 1 radio	3/4	30(.000)
	TVNZ	4195/955RHC	1	3/4	5(.632)
	TVNZ/BBC	4186/964RHC	1	3/4	5(.632)
	TVNZ	4178/972RHC	1	3/4	5(.632)
	TVNZ/Aptn	4170/980RHC	1	3/4	5(.632)
	RFO-Canal+	4095/1055L	7TV, 5+ radio	3/4	27(.500)

Receivers and Errata
inclined orbit +/-2.5 degrees
FTA SCPC (NT, Aust only)
FTA SCPC (NT, Aust only)
FTA, CA (NT, Aust only)
Pv, Nagravision, Irdeto; some FTA
CA, \$105 smart card required (p. 28)
CA, \$105 smart card required (p. 28)
CA, \$105 smart card required (p. 28)
CA, \$105 smart card required (p. 258)
Austar I-TV tests
CA, subscription available Australia
CA, subscription available Australia
CA, subscription available Australia
CA, subscription available Australia
FTA, Sydney -30 minutes time zone
FTA, purpose here unknown
FTA, purpose here unknown
NDS CA, subscription available NZ
NDS CA, subscription available NZ
NDS CA, subscription available NZ
FTA, difficult to load, full time?
Viaccess CA, some FTA at times
PowVu, FTA, news feeds
PowVu, FTA, news feeds
PowVu, FTA, ABC Melbourne feeds
'MDS' CA; 12.605/28.067/3/4
tests, paralleling 12,526H at times
TPG /Eurodec CA, occ. FTA
PowVu CA & FTA; subscription avail
PowVu CA; ch 11 DCP-CCP bootload
PowVu/CA test, same as PAS2 3776H
PowVu CA & FTA (EWTN)
parallel to 4.093V PAS2
PowVu, FTA at this time
PowVu, intermittent tests, CA+FTA
PowVu CA, WIN, ABC NT
PowVu CA, WA only - D9234
PowVu CA, some FTA
Philips MPEG-2, FTA
Pv, CA/FTA (Fox News USA)
PowVu (FTA) occ feeds
Mediasat links, PowVu, usually FTA
(PowVu) FTA, occ. feeds
FTA, testing CA, "threatening"
FTA SCPC feeds (occasional use)
PowVu FTA; # pgm chs varies
FTA SCPC/MCPC, news and sports
Napa test card, occasional
1900-2030UTC; also see 3957H
reverse link HK/Atlanta, feeds, FTA
FTA (occ. sport feeds)
1900-2030UTC; also see 4034H
FTA-typ. NTSC-occ. sport, shuttle
(PowVu) CA; levels now down
PowVu CA
PowVu CA & occ. FTA
currently FTA, lowlevel, Mid East fds
PowVu CA
Thai5 service, tests, FTA
Mediaguard CA, some occ. FTA
DMV/NTL occ. feeds, typ CA
DMV/NTL occ. feeds, typ CA
DMV/NTL occ. feeds, typ. CA
DMV/NTL occ. feeds, typ. CA
#1, 2 CA - rest FTA-France to Polyn.

SatFACTS Digital Watch: Supplemental Reference Data / March 2000

Bird	Service	RF/IF & Polarity	# Program Channels	FEC	Msym
(1701/180E)	TVNZ feeds	4044/1106R	1	3/4	5(.632)
	NZ Prime TV	4024/1126L	1	2/3	6(.876)
	RFO Polycast	3858/1292L	1	3/4	4(.566)
	TVNZ (TL)	3854/1293R	1	3/4	5(.632)
	TVNZ	3846/1304R	1	3/4	5(.632)
	10 Australia	3765/1385R	6	7/8	29(.900)

Receivers and Errata
SCPC, mixed CA and FTA feeds
PowVu CA; Auckland net feeds
FTA SCPC; East Hemi Beam-Tahiti
SCPC, mixed CA & FTA, feeds
SCPC, mixed CA & FTA, feeds
PowVu CA & FTA; #3 TBN

BOUQUETS - FTA vs. CA: Listings here show SCPC (single channel per carrier) and MCPC (multiple channels per carrier) digital transmissions which "more or less" conform to the MPEG-2 DVB "standard." Unfortunately, "conforming to the standard" is interpreted differently by the various transmission equipment suppliers - of which, Scientific Atlanta is the most notorious with its PowerVu proprietary (that means "unique to SA") method of creating MPEG-2. If you want to see REAL MPEG-2 DVB-Compliant (as in world standard) signals - try AsiaSat 2, European Bouquet (4000/1150Hz). SA "modifies" their PowerVu format in an attempt to force each programmer using its uplink equipment to also use its proprietary (PowerVu) receivers. PanAmSat, closely linked to Scientific Atlanta, virtually insists that any digital service user of their satellites use PowerVu format transmission equipment. The good news is that some clever non-PowerVu receiver designers and receiver software writers have created "quasi-PowerVu" decoding routines which in many cases outperform the PowerVu originals. If your use requires access to one or more PowerVu CA (conditional access) service, you have no choice but to purchase a PowerVu receiver. If you are only interested in FTA (free to air) PowerVu services, there are many lower cost options (see below).

All services listed in bold face (i.e. **Arirang TV**) are FTA. When MCPC services are FTA, they are also listed bold face (i.e. **Euro Bouquet**). When there are mixed CA and FTA programme channels in a MCPC bouquet, see right hand column for a bold face indication of this (i.e. **some FTA**). The primary (mostly or total) FTA MCPC bouquets are as follows: PAS4/68.5E: CCTV (3716H); Thaicom 3/78.5E: Mahar (3600H), Thai Global (3425V); As2/100.5E: European Bouquet (4000H); Optus B3 /156E: Mediasat (12.336V); PAS8/166E: NHK Joho (4065H), California Bouquet (3940H), CNNI (3780H); PAS2/169E: NBC Hong Kong (4093V), Middle East (3778V), BBC + (3743V), CCTV (3716V), California PowVu (3901H), Satcom 1-6 (3743H); Intelsat 701/180E: RFO (4095LHC), 10 Australia (3765RHC). There are far more SCPC FTA digital services than MCPC FTA digital services.

MPEG-2 DVB Receivers: (Data here believed accurate; we assume no responsibility for correctness!)

ADI MediaMate. FTA, NTSC+PAL outputs. (Pacific Digital Sys. Pty Ltd, tel 61-2-8765-0270)
AV-COMM R3100. FTA, excellent sensitivity (review SF May 1998); new version Sept. '99. Av-COMM Pty Ltd, 61-2-9949-7417.
Benjamin DB6600-CA. FTA, Foxtel/Austar w/CAM+card. Try Steffen Holz +687-438-156.
Grundig DTR1100. Mfg by Panasat (SA), very similar to Panasat 630; out of production, Irdeto capable. See Av-COMM above.
Humax F1-CI. Primarily sold for TRT(Australia), does (limited) PowerVu (not Optus Aurora approved).
Hyundai-TV/COM. HSS100B/G (Pacific), HSS-100C (China) FTA. Different software versions; 2.26/2.27 good performers, 3.11 and those with Nokia tuners also good; later 5.0 not good. SATECH (V2.26)
Hyundai HSS700. FTA, PowerVu, SCPC/MCPC. Review SF March 1999. Kristal Electronics, 61-7-4788-8906.
Hyundai HSS800CI. FTA, Irdeto (with CAM) + other CA systems, PowerVu, NTSC. Kristal Electronics, above; review SF#63.
MediaStar D7. FTA, preloaded w/ known services, exc. software (review SF July 1998). MediaStar Comm. Int. 61-2-9618-5777
MultiChoice (UEC) 660. Essentially same as Australian 660, not grey market contrary to reports. Sciteq tel 61-8-9306-3738
Nokia "d-box" (V1.7X). European, FTA, may only be German language, capable of Dr. Overflow software. Tricky to use.
Nokia 9200. When equipped with proper CAM, does Aurora, pay-TV services provided software has been "modified" with Dr Overflow or similar program (www.BAKKERELECTRONICS.COM- Note: This site shut-down by Mindport early November - may not be functioning!). Reported factory 12 mo. warranty. Peter Older, tel 61-3-5133-7911, mobile 61-0418-386287
Nokia 9500/9600. Numerous versions for different world parts; not distributed in Pacific but assistance from Av-Comm Pty Ltd.
Nokia 9800. Latest single chip version, with CI and Irdeto capable. No software for Pacific, Asia; not recommended.
Pace DVS211. NDS CA (no FTA) for Star Asia, previously used for Indovision. (Solution 42, 61-2-9820-5962)
Pace DGT400. Originally Galaxy (Now Foxtel+Austar). Irdeto, some FTA with difficulty (Foxtel Australia 1300-360818)
Pace DVR500. Original DGT400 modified for NBC (PAS-2) affiliate use, with CAM equivalent to DGT400 but more reliable.
Pace "Worldbox" (DSR-620 in NZ). Non-DVB compliant NDS CA including Sky NZ, no FTA; similar "Zenith" version.
Pacific Satellite DSR2000. Advises no longer current model (see. p. 2, here); Clone of Mediastar D7 (see above)
Panasat 520/630/635. MCPC FTA, Irdeto capable, forerunner UEC 642, 660. Out of production, spares fax ++27-31-593-370.
Panasonic TU-DS10. FTA + Irdeto CA; one of 2 IRDs approved by Optus for Aurora, but no longer available in Australia.
Phoenix 111, 222. PowVu capable, NTSC, graphics, ease of use. (111 review SF#57). SATECH(below)- 222 out of production
Phoenix 333. FTA SCPC, MCPC, analogue + dish mover. Detailed SF review Nov. 1998. SATECH 61-3-9553-3399.
Pioneer TS4. Mediaguard CA (no FTA), embedded Msym, FEC, only for Canal+Satellite (AntenneCal ++687-43.81.56)
PowerCom. FTA, PowVu, NTSC, excellent sensitivity. NetSat 61-2-9687-9903.
PowerVu (D9223, 9225, 9234). Non-DVB compliant MPEG-2 unless loaded with software through ESPN Boot Loader (see below). Primarily sold for proprietary CA (NHK, GWN+ PAS-2 Ku, CMT etc). Scientific Atlanta 61-2-9452-3388.
Praxis/DigiMaster 9600 MKII/9800AD. FTA, PowVu+analogue, withdrawn from sale in Pacific (was Skyvision-below)
Praxis 9800 ADP. FTA SCPC/MCPC, PowVu, analogue, positioner. SF review Dec '98; withdrawn from Pacific sale (below).
Prosat 2102S. FTA SCPC/MCPC, NTSC/PAL, SCART + RCA. Sciteq 61-8-9306-3738.
SatCruiser DSR-101. FTA SCPC/MCPC, PowVu, NTSC/PAL. (Skyvision Australia 61-2-6292-5850, Telsat 64-6-356-3749)
SatCruiser DSR-201P. FTA SCPC/MCPC, PowVu, NTSC/PAL, analogue, positioner - review this issue (Skyvision - see above).
Skandia SK888 (aka DigiSkan-SMS). FTA MCPC, Irdeto CAM+software upgrade. Out of production; Skandia 61-3-9819-2466
Strong SRT 4600. SCPC, MCPC, PowerVu; exc graphics, ease of use, review SF#64. SATECH 61-3-9553-3399.
Sky 21/SJ 3000ci. Claims "clone" Hyundai HSS800ci; if so, poor copy. Runs very hot, reportedly burns up smart cards
UEC642. Designed for Aurora (Irdeto), approved by Optus; limited other uses. Nationwide 61-7-3252-2947.
UEC660. Upgraded UEC642, used by Sky Racing Aust., Foxtel-limited FTA. (Nationwide - above); power supply problems.
UEC770. Single chip Irdeto built-in design for Foxtel; unfriendly for FTA. Power supply problems, not sold to consumers.
Xanadu. DVB compliant special receiver for members of SPACE Pacific (Av-comm Pty Ltd, tel +61-2-9949-7417)
Yuri HSS-100C. FTA, clone of Hyundai, V2.27 software custom to Australia (Nationwide-above).
Accessories:
Aurora smart cards. New v1.6 now available, 1.2 no longer available for RABS. Price now A\$105, Sciteq 61-8-9306-3738.
PowerVu Software Upgrade: PAS-8, 4020/1130Hz, Sr 26.470, 7/8; pgm ch 11 and follow instructions (do not leave early!)

SatFACTS Pacific/Asian FTA ANALOGUE Watch: 15 March, 2000

Copyright 2000: SatFACTS, PO Box 330, Mangonui, Far North, New Zealand (<http://www.satfacts.kwikkopy.co.nz>)

BIRD/Location	RF/IF & Polarity	Service	Errata
I703/57E	3808/1342R	Udaya TV	
	4052/1098R	WorldNet	VOA subers.
	4178/972L	MTA Inter.	
I604/602/60E	4166/984	various feeds	
I704/66E	3765/1385R	tests	
	4015/1135L	Mongolia	(SECAM)
PAS4/68.5E	3743/1407V	RTPi	(+ radio subcr)
	3864/1286V	BBC World	
	3907/1243H	Sony TV	Hindi
	4034/1116V	Doordan	(various)
	4087/1063H	CNNI	
	4110/1040H	TNT/Cartoon	
	4113/1037V	Series Ch.	
	4182/968H	MTV	
PAS7/68.5E	3470/1680V	test signal	
LM1/75E	3977/1173V	various	(Madagascar)
AP2R/76E	3745/1405V	Vasta Music	(P5 in NSW)
	3691/1459V	TEN	
Thaicom3/78E	3871/1279H	TVT	
	3760/1390V	Army TV	
	3690/1460V	MRTV	
	3685/1465H	VTV	6.6, 7.02
	3616/1534V	ETN	
	3576/1574V	ATN Bangalr	Bengali
	3554/1596V	test card	
	3536/1614V	Punjabi TV	(occ service)
	3514/1636V	Falak TV	
	3489/1661H	Vasta Music	occ tests
	3465/1685V	RAJ-TV	
Express 6/80E	3672/1478L	TK Rossija	(north beam)
InSat 2E/83E	3481/1669V	Sun TV	
	3562/1588V	Vijay/Asianet	aud. 5.5/6.6
	3599/1551V	JayaTV	
	3810/1340V	DD1-Tamil	"
	3850/1300V	DD1-National	"
	3930/1220V	DD2 Metro	"
	3970/1180V	Teluga 1	"
	3998/1152V	sport feeds	"
	4035/1115V	Sun TV	"
	4060/1090V	Surya/Sun TV	"
	4093/1057V	DD7	"
ChnStr1/87.5E	3880/1270H	occ feeds	P4 NSW, Ntsc
ST1/88E	3550/1600V	test card	
	3582/1568V	Nila TV	(vintage TV)
CIS S6/90E	3675/1475R	RTR1	P3 NSW
	3875/1275R	Orbita 1	
	3916/1234R	RTR II	
	3935/1215R	Orbita II	
MeSat-1/91.5E	3710/1440H	VTV1,2, 4	
	3880/1270H	RTM-1	
InSat 2B/93.5E	4165/985H	India Metro	NSW on 3.7m
	4125/1025V	India National	NSW on 3.7m
	4080/1070V	DD7 (Tamil)	
	4070/1080H	DD9	
	3970/1180V	DD9 (Kan.)	
	3882/1268V	DD1	
	3840/1310V	DD?	
	3762/1388V	DD4	
AsSat2/100.5E	3642/1508H	ERTU Egypt	
	3660/1490V	feeds, tests	
	3680/1470H	feeds	
	3860/1290V	feeds	

BIRD/Location	RF/IF & Polarity	Service	Errata
(As2/100.5E)	3885/1265H	WorldNet	VOA subers
	3960/1190H	CCTV4	
	3980/1170V	RTPi	+5 radio sves
CIS S21/103E	3675/1475R	RTR	
	3875/1275R	Vrk Apt	
AsSat3S/105.5	3660/1490V	Z-Marathi	audio 6.6
	3680/1470H	CETV	
(temp FTA)	3800/1350H	Star Sport	NTSC
(temp FTA)	3840/1310H	Channel [V]	NTSC
	3900/1250V	AlphaTV Punja	
(temp FTA)	3920/1230H	Phoenix Ch	NTSC
	3940/1210V	Zee India	
	3980/1170V	Zee TV	
	4140/1010V	Angla Bangla	
	4060/1090V	Zee Cinema	(Starcrypt)
	4100/1050V	PTV2/World	
	4120/1030H	CCTV	NTSC
T'kom1/108E	4000/1150H	tests	
PalapC2/113E	4160/990H	(France) TV5	
	4140/1010V	Brunei + feeds	
	4120/1030H	MTV Asia	
	4080/1070H	Herbalife	+ tests
	4040/1110H	CNBC	
	3970/1180V	CNNI	
	3880/1270H	Aust ATN7	
	3840/1310H	TVRI	tests
	3742/1408V	RCTI	English suber
AsSat1/122E	3677/1473V	Test card	& 3933/1217H
ChinS 6/125E	4085/1065V	feeds	seldom seen
JcSat3/128E	3768/1382V	feeds	occ., P5 NZ
	4085/1065V	test card	NTSC. 6.8 aud.
Ap1A/134E	4160/1050V	CETV	
	3980/1170V	CETV1	
	3900/1250V	CETV2	
Ap1A/138E	4160/990H	CCTV7	
S7/140E	3675/1475R	ORT Moscow	+/-4d. inclined
	3875/1275R	feeds, tests	
LMAP2/142.5	3675/1475L	occ. tests	+/- 3 deg inc.
Ag2/146E	3787/1363H	GMA	P1/2 s. eqtr
Me2/148E	4080/1070H	test card	occ. use
PAS8/166.5E	3880/1270V	test card, feeds	not full time
	3865/1285H	Napa test card	not fulltime
PAS2/169E	3940/1240V	Napa test card	
1802/174E	4166/984R	Feeds	
	4177/973R	Feeds	
I702/177E	4166/984R	Feeds	inc. KBS Korea
	4187/963R	Occ. feeds	
I701/180E	3810/1340R	Occ. feeds	
	3841/1309L	RFO	East Beam
	3845/1305R	Occ. feeds	inc. from USA
	3930/1220R	USA net feeds	FTA & encrypt
	3975/1175R	Occ. feeds	

PAS4/68.5E	3785/1365V	Discovery India	BMAC
	3860/1290H	ESPN India	BMAC
Ap2/76E	3960/1190H	HBO Asia	GI Digicipher2
C2/113E	3930/1220H	Filip. Peo. Net	GI 1.5 MPEG
Ap1/138E	4100/1050V	ESPN	BMAC
PAS2/169E	4028/1122H	ABS/CBN	GI 1.5 MPEG

BEGINNER TECHNICAL INFORMATION

SPACE Pacific received a call early in March from a Seventh Day Adventist church in the greater Auckland area. They had purchased a 3m size dish from a chap for \$3,000. Installed. Such a deal. But the dish was not performing very well and they were not certain - being non-technical laymen - whether the dish, the LNBF or the receiver was at fault.

The receiver is a Scientific Atlanta D9234. Experience with several of these has taught us they are not very sensitive (their tuner has a higher noise threshold than many of the so-called consumer units on the market). This might be part of the problem, we suggested. We advised them to contact a local Auckland area installer whom we knew to be competent.

A couple of days later he called to ask some advice. Taking a Phoenix 333 to the site, he had been successful in loading the Seventh Day feeds on PAS-2 (they are PowerVu but mercifully, FTA) while the D9234 sat there being deaf. Upon closer inspection of the dish, he discovered the slide in mesh panels were very badly wrinkled, having been forced into the normal alignment slots by someone who was either in a hurry or did not know how to properly assemble the dish ribbed super structure. "They were wavy, as much as half an inch (1+cm) and all across the surface" he reported. With feed time rapidly approaching and a Church filling up with members who expected to see their weekly telecast, he found some fishing line and quickly strung some back stays from the mesh to the rear support pipe of the dish to take out the larger ripples.

Very possibly the 3m dish was warped because it was second hand - and the installer had to reassemble it after he or someone else took it apart; badly. Or perhaps the dish shipping carton was dropped in transit bending some super structure stays. As a practical matter, the dish could be made far better than it was and anyone with a couple of experienced hours on their hands could make it better.

"I offered to try to correct the assembly mistakes but warned that if the dish was permanently warped because of a structure failure, the next step might be a complete replacement" reported our Auckland installer.

Anyone who cares and has the time can always make a dish better than it is. Nobody puts them together perfectly, the holes don't always align, the bolts may not always fit, and with slide in panel mesh dishes, the panels may not go properly into the channels on the struts. But - when you represent yourself to be a "professional installer" or you are a customer buying service from someone who so represents, you are promising or being promised at least the best effort possible. Especially when you pay \$3,000 for a \$20 Taiwan LNBF, 30 metres of RG-6, a pole in the ground and a US\$600 mesh dish.

There is a descriptive word for this category of installer - cowboy. It means a guy (or gal if there are lady installers out there who fit the definition) who rushes into a job, thinks more of his time spent on the job (little is best, lots is too much) than of the quality of the workmanship. In this case, even before our Auckland installer arrived on the site, the Seventh Day Adventist Church people knew they had been "taken" by a cowboy.

The unfortunate post script to this story is that this same cowboy has been involved with very similar problems - some with quite large dishes - throughout much of North Island, New Zealand. There are no tests in this business, no mandatory licenses, no way to qualify one's skills as a professional. If a guy talks the talk and says the right things to a novice buyer, he will probably get the job. This is especially true where you can count the people who claim to be C-band dish installers throughout all of North Island, New Zealand on the fingers of one hand.

But if you are a consumer, and beginner in the business, there are things you can do to protect yourself. First, get at least two bids for the job. When you select one, call at least one other and say "I am sorry you didn't get the job - but) I will pay you \$50 to come out here after the work is completed and tell me if it has been done correctly." Then let the guy who got the job know before he starts that you plan to withhold payment for the work until you have an after-installation "second opinion" from a competitive installer. If the fellow who won the work balks at that, you are better learning of his reluctance to be inspected before he does shoddy work. Next, get a written description of the system to be installed and his signature on a piece of paper that says "I will be responsible for the way this system performs." Most dish manufacturers offer a one year warranty on parts, not the same as an assembled dish but a benchmark for the dealer's own promised support none the less. And good luck!

TUNING IN THE INDUSTRY'S TV PROGRAMME

SPACE Pacific, the Asia-Pacific industry membership trade association, has produced (and continues to produce) a series of one hour television programmes. These "SPACE Pacific Report" shows, hosted by Bob Cooper, cover a range of topics of interest to installers and enthusiasts. Show numbers and content are as follows: #9901- Spectrum Analyser techniques, #9902- Feeds and LNBS, #9903- Dish antenna designs and problems, #9904- The dish marketplace, and, "tiny parts," #9905- Dr Overflow (Nokia) software, #9906- How the uplink works (tour of RCA's Vernon Valley site), #9907- Uplink Two, including uplink transmitters, #9908- Digital Basics (Mark Long), #9909- Real World Installs (Mark Long), #9910 - Installing a polar mount dish (in production); "Report" is broadcast by Mediasat on Optus B3, 12.336Vt, ad-hoc channel 3 (Sr 30,000, FEC 2/3) with the following coming-weeks schedule: **Sunday March 19** - Show 9909 0200-0300 UTC (1400 NZT, 1300 AESummerTime, 0900 Western Australia; repeats 0700 UTC). **Sunday March 26** - Show 9901, (1400 NZT, 1200AET, 0900 Western Australia); repeats 0700UTC; **Sunday April 2** - Show 9902, same times as March 26; **Sunday April 9** - Show 9903, same times as March 26; **Sunday April 16** - Show 9904, same times as March 26; **Sunday April 23** - Show 9910 - *premiere showing*, same times as March 26 (*Premiere showing*). SPACE Pacific Report has also been broadcast by Westlink, *Aurora service on Optus B3, vertical* (12.595, Sr 30,000, FEC 3/4 - requires Optus Aurora card but is otherwise FTA). Westlink will again carry SPACE Pacific Report when new shows currently in planning are produced and available; details here when air schedule is complete. In the event of schedule changes, SPACE Pacific attempts to pre-announce which show(s) will appear through the SatFACTS Web site prior to each weekend (<http://www.satfacts.kwikcopy.co.nz>). Shows are digitally mastered and VHS copies are available from SPACE Pacific - see insert card between front cover and page 1 this issue.

Sponsorship of SPACE Pacific Report. In general answer to queries - AvComm, Satech and Sciteq have contributed corporate funding to make possible the production of the first set of nine SPACE Pacific Report programmes. Additional funding from Ikusi Australia NZ Pty Ltd. has been received for final production of show 9910. Funds derived from sale of VHS tape copies are also an important element in meeting the (A)\$1,300 overhead of each show. Mediasat and Westlink donate the time to broadcast the programmes, and both are to be commended for this support. As we move into the next group of (10) programmes now being scripted and shot, we solicit financial support from members of the industry or those with commercial activities they wish to have associated with the project (see insert card between front cover and page 1, SatFACTS for February 2000). To discuss your own support, contact Bob Cooper at telephone 64-9-406-0651, fax 64-9-406-1083, e-mail Skyking@clear.net.nz. C-band wide area service is still being negotiated - keep the faith - it may happen yet!

WITH THE OBSERVERS

AT PRESS DEADLINE

ABC NT is back again (see report here, Optus B1). Zee TV's test of digital now reported on 3700/1450Vt As3 (Sr 27.500, 3/4) but check 4020/1130 as well. On Thaicom 3, Alpha TV SCPC operating on 3430/1720Hz, Sr 3.254, 2/3 FTA.

For day to day updates:

<http://www.satfacts.kwikkopy.co.nz>.

AsiaSat 2/100.5E: "China TV/MSTV (Taiwan) has started on 3791/1359Vt, Sr 4.340, 3/4 - FTA at this time" (D. Leach, NSW). "BBC World Service radio is now on 3660/1490Vt as audio-extra; Sr 27.500, 3/4 with APID of 670" (M, Thailand).

AsiaSat 3R/105.5E: "5 channels on 3760Hz/1390Hz, Sr25.000, 7/8 - Now TV is FTA, rest CA" (D. Leach, NSW). "Zee TV bouquet on air for a few days around 1 March, then gone again - 4020/1130Vt, Sr 27.000, 3/4 - included Music Asia, Alpha TV Marathi and Alpha TV Punjabi" (S. Johnson, NZ).

Chinasat 22/98E: "I believe this satellite is inclined as it requires tracking every 60 minutes" (D. Leach, NSW).

Chinastar 1/87.5E: "Colour bar test pattern on 3880/1270Hz" (D. Leach, NSW).

JcSat 3/128E: "Miracle TV/TBN loads on 3990/1160Vt, Sr 12.997, 5/6. Also here two test patterns, one of which occasionally has CBS USA programming, plus 2 CA services. On Asian Bouquet 3960/1190Vt, Sr 30.000, 7/8, need 15 minutes to load on Xanadu - has one China TV channel FTA, rest are CA (others report CSTV-MTV, ETTV, Unique Satellite TV, SET and BNE TV have been FTA for days at a time)" (D. Leach, NSW).

InSat 2E/83E: "Vijay has moved 3562/1588Vt from 3555/1595Vt and gone down 2 dB here; JayaTV now on 3599/1551Vt, also down 2 dB from former frequency" (D. Leach, NSW).

Intelsat 701/180E: "Scientific Atlanta multiplexer used for 10 Australia bouquet (3765/1385R, Sr 29.900, 7/8) scheduled for changeout to newer model around 1 April" - and not a moment too soon! Ed. (Howard Fine, California).

Intelsat 702/174E: "Thai TV5 (Global) service on 12.654Hz seems to have stabilised after early February drops in level which Intelsat blamed on changes being made in the satellite" (B. Richards, Australia). You might check 12.730 and 12.610 on the same Australian beam for other non-TV transponders in use.

Optus B1/160E: "ABC-NT on 12.256Vt dropped out here March 5, is this temporary?" (F. Kosmalski, NZ). "Has been reliable on 90cm dish, now gone here" (L. Mathews, Auckland). "Time offset from NZ while on summer time has been -3.5 hours" (R. Whitehead, NZ).

Optus B3/156E: "Sky News Australia will close down on Mediasat (12.336Vt), probably before end of March" (P.

COMING UP

02:00 GMT 21 October

0230 World 1

0300 Life! 1

0315 Showbiz Daily

0400 Reuters Reports 1

0430 Update 1

0500 Sports 1 Replay

REUTERS

Help Desk +44 171 542 2244

News feeds. Many don't realise that those canned, "sound byte" news reports one finds on CNN, local TV, CNBC and other international sources are typically sent via satellite to news agencies for redistribution to world clients. APTV, Reuters, CNN, ABC USA all circle the globe with dedicated satellite channels that feed these typically "raw" (as in not edited or lightly edited) feeds around the clock. For an "insider look" at what is really happening, before the "news managers" turn it into sound bytes, check out some of these:

I703/57E: 4018L - Sr 6.000, FEC 3/4

As2/100.5E: 3799Hz - Sr 5.632, FEC 3/4

As2/100.5E: 3790Hz - Sr 5.632, FEC 3/4

As2/100.5E: 3775Hz - Sr 5.632, FEC 3/4

Ap1/138E: 3742Vt - Sr 5.632, FEC 3/4

PAS-8/166.5E: 3780Hz - Sr 25.000, FEC 3/4

Intelsat 701/180E: 3765R - Sr 29.900, FEC 7/8

Mullen, Australia. PIDs for new ATV channels on 12.532Vt are Lashkara VPID 2048, APID 2049 and Gujari VPID 2064, APID 2065. I-TV, Austar's new interactive offering, running loop to promote service on 12.376Hz, Sr 29.473, 3/4 (VPID 512, APID 640). Odyssey has replaced Christian TV on 12.564 Austar/Foxtel.

WITH THE OBSERVERS: Reports of new programmers, changes in established programming sources are encouraged from readers throughout the Pacific and Asian regions. Information shared here is an important tool in our ever expanding satellite TV universe. Photos of yourself, your equipment or off-air photos taken from your TV screen are welcomed. TV screen photos: If PAL or SECAM, set camera to f3.5-f5 at 1/15th second with ASA 100 film; for NTSC, change shutter speed to 1/30th. Use no flash, set camera on tripod or hold steady. Alternately submit any VHS speed, format reception directly to SatFACTS and we will photograph for you. Deadline for April 15th issue: April 5 by mail (use form appearing page 34), or 5PM

NZT April 6th if by fax to 64-9-406-1083 or Email

skyking@clear.net.nz.

SatFACTS March 2000 ♦ page 29

AT

Sign-off

Just when you thought you could sleep at night ...

Imagine this. One satellite delivering 2,142 separate transponders with the technical capacity to send 25,704 separate TV programme channels into your home.

While we have been concentrating on the wondrous developments in the Clarke orbit belt over the equator, another bunch of guys and gals have been quietly dropping reels of multi-gigabit fibre optic cable onto the ocean floor laying out an entirely new world of "fibresphere" connections. Satellites are being replaced on important "routes" with almost incomprehensible capacity submarine fibre optic cables. Two new undersea cables connecting Europe with North America have the bandwidth to deliver 2.5 terabits of data each. How much is that? A satellite transponder might manage between 45 and 60 megabits of data. A gigabit is 1,000 times more than a megabit and a terabit is 1,000 times more than a gigabit. In plain English? 2.5 terabits can handle 500,000 full motion TV programme channels at a time!!!

Talk about channel surfing.

Late in February Telstra Australia and Austar Australia announced a new business initiative. As you read these words, they are starting a 120 gigabit capacity submarine cable from Auckland around New Zealand's North Island west coast to Wellington, thence to Christchurch. Telstra Saturn Limited is the new name for what has been a struggling attempt in the Wellington region to compete with pay-TV giant Sky NZ and telephone giant Telecom NZ. This 120 Gbps capacity cable will allow Telstra Saturn to send back and forth the equivalent of nearly 26,000 simultaneous TV channels. In the Auckland, Wellington and Christchurch markets, T-S is laying / will lay out a fibre optic plus coaxial cable network connected to this submarine cable. Individual homes, businesses will gain fibre optic connected access to 10 Mbps Internet, hundreds if indeed not thousands of TV channels, lower cost telephones, video movies on demand (VOD). And God knows what else in the new century.

Telstra and Austar are taking advantage of the incredible cost savings possible with high capacity submarine cables. They say NZ\$100 million will be spent on the new cable. Worry not - they are entering a marketplace that spends NZ\$4.5 billion each year for telephone and auxiliary connections alone and they expect to capture upwards of 20% of that market. In addition to the undersea cable, they expect to invest NZ\$1 billion in wiring Wellington, Auckland and Christchurch with two-way, high speed, high capacity fibre and coax that comes right into the house. Within five years, it will be entirely feasible for someone connected to this system to operate their own, private, television channel from a corner of their study or bedroom because the network will have the technical ability to send out to the system full motion, high quality television from individual subscriber homes. The surprising factor in all of this is the rapid drop in costs for doing just such a thing from your own home.

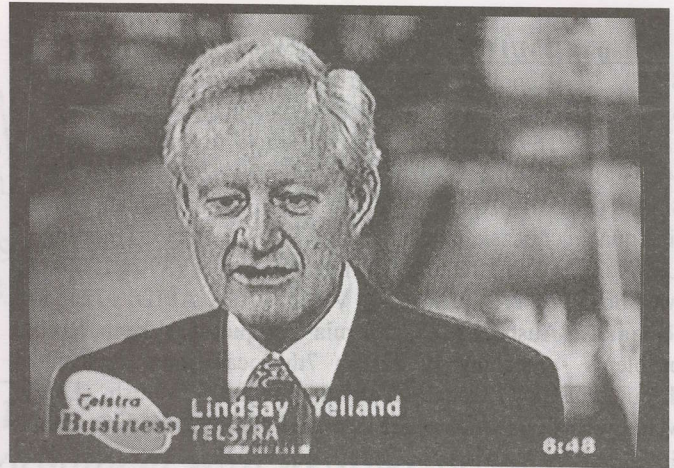

Lindsay Yelland, Telstra Saturn Board Chairman.
"We have a ship standing off the coast ready to begin laying the cable."

Based upon twenty year capital cost depreciation schedules, the "real" cost of this 120 Gbps submarine cable can be stated in terms of break-even revenue for Telstra Saturn. At 400 kbps (the speed of current satellite download technology through a group such as IHUG), Telstra Saturn will pay for this new cable if they collect 1.1 NZ cents per hour between Auckland and Christchurch. Not per minute - *per hour*. Or, 26.4 cents per day - \$96.36 per year. Of course these guys are not in business to break even and they do have some operating costs. Compare however these two numbers:

- 1) 125 users,
- 2) 3,000,000 users

A 50 Mbps satellite transponder fully loaded with 400 kbps Internet traffic is capable of handling 125 simultaneous users. The Telstra Saturn submarine cable will handle 3,000,000 simultaneous users at 400 kbps.

Terabit cables already operating between the USA and Europe are the forerunner of Petabit (Pbps) cables now on the drawing board. A Petabit is 1,000 times larger than a terabit. The existing Terabit cables are already larger in capacity than all of the satellites now functioning above earth. *All of them, together.* A Petabit cable will be - well, would you believe 200,000,000 (that's 200 million) simultaneous TV channels in one cable?

Satellites are not going to roll over and play dead, of course. They will always offer flexibility in routing, access to remote locations, ease of connection and disconnection from virtually any spot on earth. A Petabit cable that ends one block from your house might as well be on the next planet over for all of the good it will do you. If you are not connected, you are simply *totally* out of the loop.

The world is rapidly moving to the technical ability to deliver hundreds/thousands/millions of simultaneous TV channels through fibre optics directly to homes and businesses. People who live "on the loop" will be significantly advantaged over those who live a block past the end of the system. The real technical answer to attempting to compress megabit data files containing live motion TV programming through existing copper wire telephone circuits is not to attempt more and more compression. Rather, it is to finally bite the bullet, run fibre to the home and get on with beating the crap out of satellites and terrestrial delivery systems. Rupert Murdoch's guys know this and that's why we will see them slowly disengage from satellites over the next five years wherever possible.

THE 2000 SATELLITE EXPLOSION IN THE PACIFIC/ASIA!

Two new Russian birds are on the way!
Stay tuned with SatFACTS!

- ENTER my 12 MONTH subscription to SatFACTS starting with April 15th issue (rates below)
 ENTER my 36 MONTH subscription to SatFACTS starting with April 15th issue (rates below)

NAME _____
Company (if applicable) _____
Mailing address _____
Town/city _____ Country _____

Amount to send: 1 year - NZ\$60 (inside New Zealand) / A\$96 (inside Australia) / US\$60 (outside of NZ and Australia) or 3 years - NZ\$140 / A\$220 / US\$150 if by cheque. VISA or Mastercard? See form below and return with order. Return to: **SatFACTS, PO Box 330, Mangonui, Far North, New Zealand** or if by VISA or Mastercard fax to 64-9-406-1083

IF YOU ARE IN AUSTRALIA - See AV-COMM Pty Ltd Advert p. 31!

USE THIS FORM ONLY WHEN CHARGING ON VISA/MASTERCARD

Please charge my **VISA/Mastercard** as follows:

- ONE Year of SatFACTS MONTHLY (NZ\$60, A\$96, US\$60)
 THREE Years of SatFACTS MONTHLY (NZ\$140, A\$220, US\$150)
 SATELLITE TELEVISION: The Booklet (NZ\$10, A\$12, US\$10)
 One Year of COOP'S TECHNOLOGY DIGEST (NZ\$125, A\$125, US\$125)

Indicate charge card type: VISA Mastercard

Name (as it appears on **VISA / Mastercard**) _____

VISA/Mastercard Number _____

VISA/Mastercard expiration date _____

Instructions: If ordering by mail, return this complete (3-part) card or a copy of same (to **SatFACTS, PO Box 330, Mangonui, Far North, New Zealand**); if order by FAX, send full card as a single sheet to **64-9-406-1083**

ALL COPIES OF SatFACTS Monthly are sent via Air Parcel Post world-wide!

SUPPLEMENTAL MATERIALS from SatFACTS MONTHLY: Order Form

- SATELLITE TELEVISION:** The Booklet. Excellent introduction to home dish ownership for the layman, including major contributions from the father of geostationary satellites - famed science fiction writer *Sir Arthur C. Clarke*. The perfect tool to help the satellite system seller explain home satellite TV to the consumer. From SPACE Pacific. NZ\$10 / A\$12 / US\$10, airmail.
- COOP'S TECHNOLOGY DIGEST.** For the really serious enthusiast, investor, business person in satellite television and allied leading edge technologies. Ten issues each year, jam-packed with information you will not find anyplace else. "Coop" routinely culls more than 60 publications world-wide, terribly expensive newsletters, Internet and his hundreds of private contacts to keep you right at the leading edge of technology on the REAL changes underway in telecommunications. Conveniently issued near the **first of the month**, creating an excellent time-line-filler between the mid-month issues of SatFACTS. Now in the **6th year**, airmail world-wide. Normally NZ/A/US\$250 per year - for SatFACTS subscribers special 50% discounted price of NZ/A/US\$125.

OBSERVER REPORTING FORM - Due April 5, 2000

- NEW programming sources seen since March 1st: _____
- Changes (signal level, transponder, programming content) in pre-existing programming sources since March 1st: _____
- OTHER (including changes in your receiving system): _____

NOTE: Please use P1 - P5 code when describing signal levels and receiver IF/RF settings.

Your Name _____
Town/City _____
Make/size dish _____ LNB _____ Receiver _____

Your email address _____ if you have one!

RETURN: SatFACTS, PO Box 330, Mangonui, Far North, NZ, fax 64-9-406-1083, Email Skyking@clear.net.nz

CLIP & SAVE - Recent and Scheduled Launches of new satellites

Recently launched - status uncertain

- 98E** / Chinasat 22, C-band transponders, is closely spaced to AsiaSat 2 at 100.5E (now testing)
- 162E** / (Japanese) Superbird 4 with 23 Ku transponders, will replace Superbird B1 and be called Superbird B2

Scheduled launches - subject to the inevitable launch delays

- 105E** (March 21) / AsiaSat L-band (1452 MHz +) stereo radio service
- 83E** (March 21) / InSat 3B with 3 Ku, 12 C and 1 S band transponder; collocate with InSat 2E
- 80E** (March 29) / Express 6A with 5 Ku, 12 C transponders; will replace Express 2
- 145E** (April) / Gorizont 33 with 1 Ku, 7 C transponders (inclined orbit by design) - last Gorizont built
- 108.2E** (June-September) / GE2A, 36 Ku, to be collocated with GE1A (see below)
- 115.5E** (August or after) / Chinasat 8, long delayed 16 Ku, 36 C transponders
- 108.0E** (September) / GE1A, 28 Ku, collocated with GE2A scheduled for previous launch
- 91.5E** (September) / Measat 3, Ku and C
- 68.5E** (October - December) / PanAmSat 10, 24 Ku 11.45-11.700, 12.25-12.75 and 24 C 3.7-4.2
- 90E** (December) / Express K1, 20 Ku and 32 C
- 62E** (January-March 2001) / Intelsat 901, 12 Ku, 44 C
- 60E** (January-March 2001) / Intelsat 902, 12 Ku, 44 C

IS it just a COINCIDENCE
Members of SPACE have more work
than they can handle?



YES - send me information about how joining SPACE Pacific can lead me to more, profitable work!

NAME _____

Company affiliation (if any) _____

Mailing address _____

Town/city _____ postal code _____ Country _____

Sky Vision Australia

A Proudly Australian owned and operated company



SAT CRUISER DSR-101 MPEG 2 DVB / POWER Vu RECEIVER

***Latest Model – New Features
Best value receiver in Australia !***

Trade price - quoted to established dealers

- √ The ideal consumer orientated receiver with features that will please the enthusiast !
- √ Pre-programmed with all active TP's from Asiasat 2, Palapa, PAS 2 ,PAS 8 and more
- √ 10 spare user defined satellite positions for future satellite launches
- √ Simplified manual TP entry – TP Frequency is the only required parameter !
- √ Auto Symbol rate – Auto FEC – Auto PID's – Auto Polarity (LNBF)
- √ Satellite naming/editing – Channel naming/editing
- √ Alternate audio channels accessible from remote control
- √ On-board NTSC – PAL 50 Hz convertor – compatible with any PAL TV
- √ On-board Digital TELETEXT decoder – no need for Text capable TV
- √ 5 language menu - English (default) Spanish / Italian / French / German
- √ Consumer friendly graphical interface – Easy to install !
- √ UHF Ch 21-69 Software controlled RF Modulator – Low spurious emissions
- √ Low threshold dual bandwidth tuner – Dual SAW filter IF stage
- √ C Tick certified to comply with Australian Communications Authority standards
- √ Ultra reliable SMPS module – not a single reported failure to date !
- √ Full colour photographs and screen shots available from our web site
- √ 12 month replacement warranty – With an optional extended warranty plan
- √ Feel free to call one of our friendly staff for more information !

DSR-201P Analog/Digital/Positioner receiver **Trade price** - quoted to established dealers

Export – Wholesale – Trade sales

Web Site: <http://www.bigfoot.com/~skyvision>

E-mail: skyvision@bigfoot.com

Tel: 02 62925850

Fax: 02 62925890

ECHOSTAR

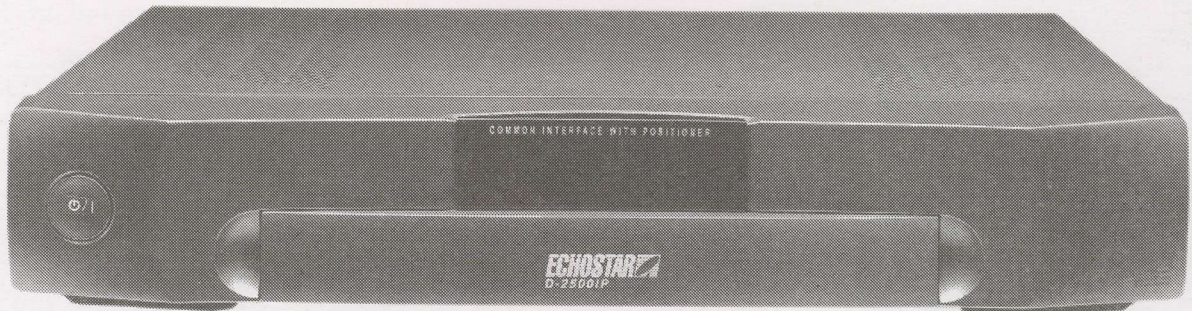

D-2500IP

Full featured Digital Receiver Positioner with Common Interface

Sciteq is proud to introduce the new Echostar D-2500IP
MPEG-2/DVB compliant DVB-S IRD with built-in Positioner.

Features include

- Built in Positioner (36V, 5A)
- DVB Common Interface (2 slots)
- Teletext
- 50 satellites
- 2900 channels
- Manual PID entry
- SCPC/MCPC
- Channel naming
- Satellite groups with own skew settings
- Electronic Programme Guide

DVB Common Interface

2 slots, PCMCIA type
(1 and 2 housings)

Tuner/Demodulator

Receiving Freq: 950-2150MHz
IF connector: F-type 1input, 1 output (loop through)
LNB Control: 0/12V, 13/18V, 22kHz,
DiSEqC 1.0, Mechanical and
Magnetic Polarizer
Demodulator: QPSK, C/Ku band
Symbol Rate: 2-45Msym/s

In/Outputs

Scart connectors: TV, VCR, AUX
Cinch connectors: Audio L/R, Video
UHF modulator: CH 21-69, PAL B/G, I, D/K
RS-232: 9-pin D-sub male
SVHS connector

Quality products distributed by:



Phone: +61 8 9306 3738 Fax: +61 8 9306 3737
sales@sciteq.com.au <http://www.sciteq.com.au>