

12-11-99 SAM

Bob Cooper's

NOVEMBER 15 1999

# SatFACTS



MONTHLY

Reporting on "The World" of satellite television in the Pacific and Asia

## IN THIS ISSUE

**HSS800ci**  
answers multi  
card challenge

**RF Distribution**  
and the passive  
components

**MadMax:**  
Man without  
a country?

- ✓ Latest Programmer News
- ✓ Latest Hardware News
- ✓ Latest SPACE Pacific Reports
- ✓ Cable TV Connection

Vol. 6 ♦ No. 63  
Price Per Copy:  
NZ\$9/A\$10/US\$7

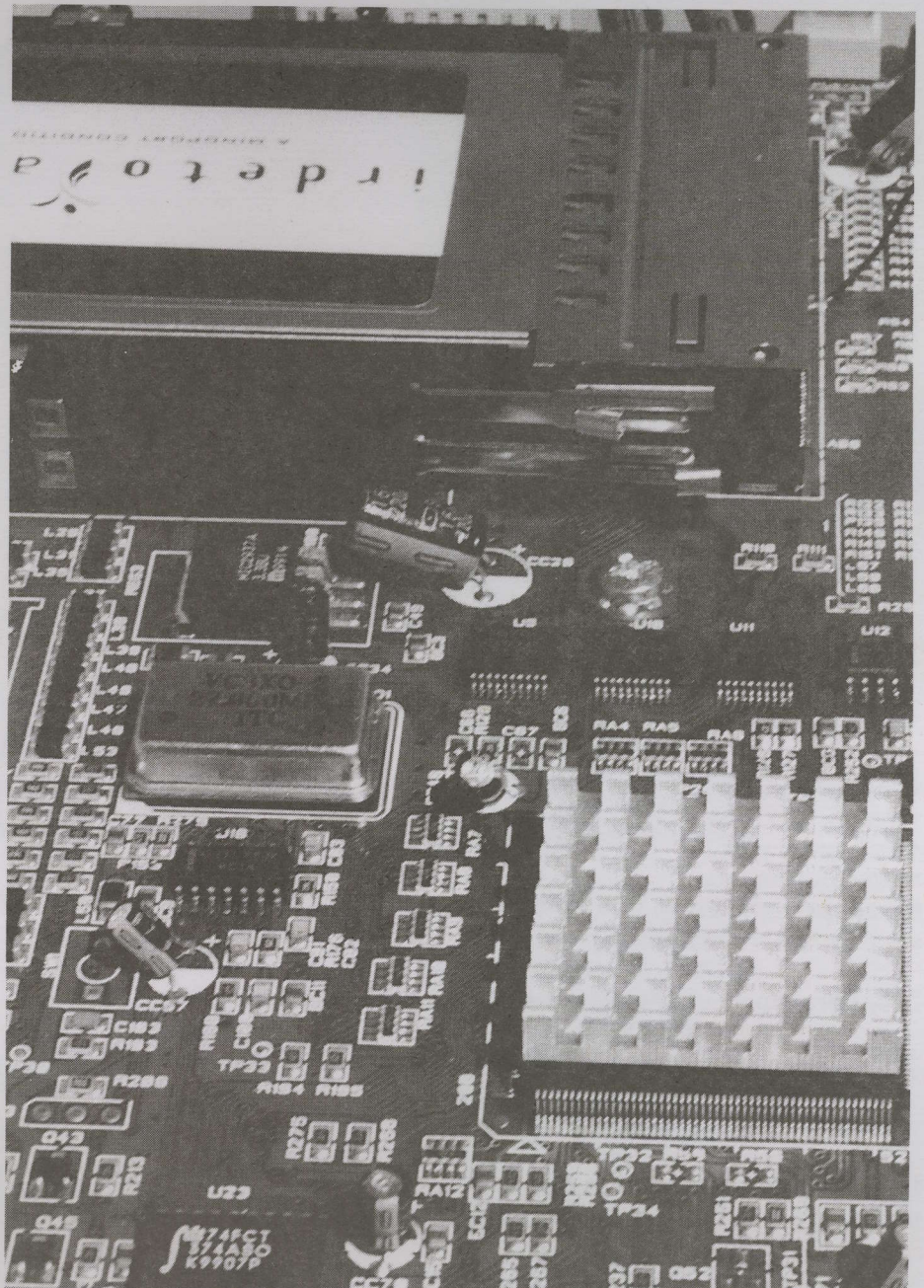



# Paraclipse<sup>®</sup>

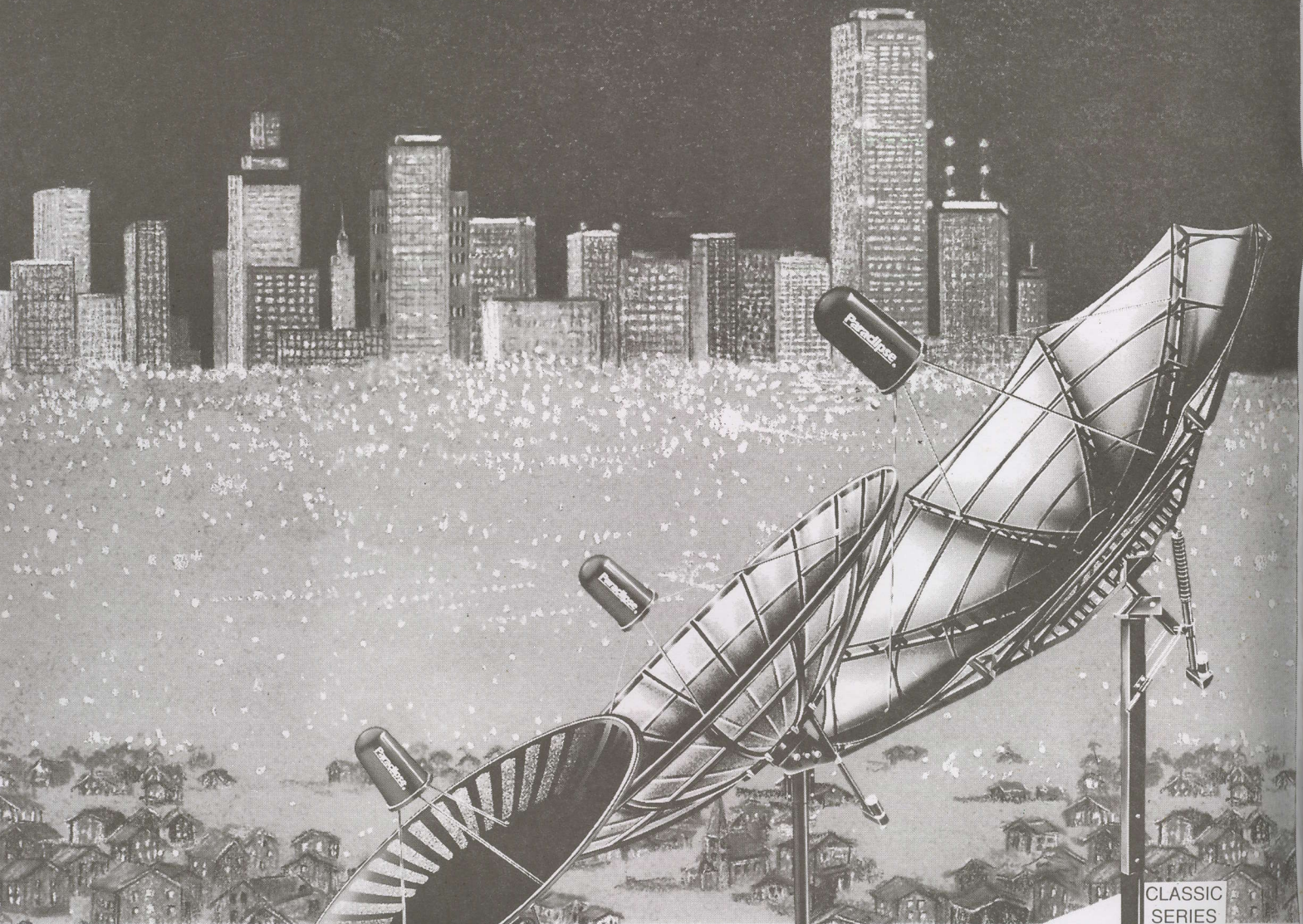
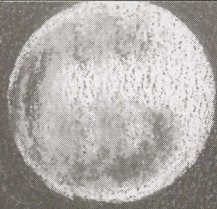

CLASSIC  
SERIES

ECLIPSE  
SERIES

HYDRO  
SERIES

When quality, strength, and accuracy are your main requirements, **Paraclipse** antennas are your first choice.

Only **Paraclipse** offers such variety; four distinctly different series: the Truss-Ribbed Classic, the Courier Deliverable Eclipse, the Stretch Formed Hydro, the Commercial Patriot.

Every **Paraclipse** model sets the industry standard in its class, worldwide.

Distributed in Australia & the Pacific by

**SATECH Satellite  
Communication  
Technology Pty. Ltd.**

18/477 Warrigal Rd, Moorabbin  
East, Victoria, Australia 3189  
tel 61-3-9553-3399  
fax 61-3-9553-3393

**Paraclipse<sup>®</sup>**  
HIGH PERFORMANCE ANTENNAS

★ MADE IN  
AMERICA

Paraclipse Inc.  
2271 29th Avenue East, Columbus, Nebraska USA 68601  
Telephone: (402) 563-3625 Fax: (402) 564-2109



# SPACE PACIFIC REFERENCE MATERIALS

(updated November 15, 1999)

to help you do a better job, profitably

Some items in limited quantity (marked LtdQty); many have special SPACE member discounts

## SPACE Pacific Report (# 9901, 9902, 9903, 9904)

The television programme, direct to you from digital master on E240 VHS tape, PAL format of course. Show 9901: "It is your signal, too" and "Fun and games with the spectrum analyser." Show 9902: "Feeds and LNBS" - understanding how products differ. And, "Mark Long's Thumbnail History of home satellite TV" featuring the real pioneers of the 70s and 80s! Show 9903: "Dish antenna critique," why some dishes work better than others, plus Mark Long on installing your own dish, and, Richard Brooks on PVRs. Show 9904: "Who buys DTH systems?" explores the marketplace, plus, "Understanding Tiny Parts" looks at connectors, line-amps and splitters. Four hours as currently running on Mediasat & Westlink- digital mastered to you for the exceptional price of \$55 including shipping and two bonus items - "Satellite Television (The Booklet)" featuring material by Sir Arthur C. Clarke, and, the infamous CMT satellite pencil-writer! (see order form, below). In stock, shipped within 72 hours. (No SPACE discount)

## Shows 9905, 9906, 9907, 9908 & 9909

The television programme - the latest releases (even before they appear on Mediasat, Westlink!). As above. Show 9905: Robin Colquhoun and the Dr Overflow software for the Nokia; Show 9906: How the uplink works - possibly the best programme topic ever created. Show 9907: Part two of uplink. Show 9908: Instructor Mark Long's "Digital Basics." Show 9909: Mark Long's "Installation Basics" with emphasis on Ku service. Shows 9905, 6, 7, & 8 now being shipped. \$60, no SPACE discount.

## World Sat TV '92

Close out - a few copies remaining! All of the basic fundamentals are here, at a price that is too good to be true. Hey - the quantity is very limited (LtdQty) and we need to clear out the shelf space. \$10 and if you are a SPACE Member, it comes down 30% to \$7! Having a complete satellite TV reference book doesn't get any cheaper than this.

## TB 9404 DTH Systems

Direct to Home: Satellite System Installation Techniques. There are many-many NEW people getting into home satellite system installation. And we receive several calls each day asking us to point them at a "basic tutorial" that will explain how a home dish system works, how you install it for proper performance. This is it. Without question, the very best quick tutorial on what a home dish system is, how it works, where the problems develop. If you are new to the DTH field, buy this and commit it to memory. Very slight New Zealand bias, not enough to hurt its value world-wide. And if you are looking into multi-set installations such as motels and hotels and condominiums, also order TB 9405 'SMATV Systems' (below; the pair make it painfully clear where mistakes are commonly made). Also see SatFACTS October and this issue - 1999 for RF Distribution System articles. TB9404 originally prepared by Coop for an Asian DTH technology conference, LtdQty \$10 (SPACE discount).

## TB 9405 SMATV Systems

Satellite to room - Commercial SMATV (Satellite) Dish Installations. The easy part is the satellite dish or dishes. The difficult challenge is getting all of those signals - including the terrestrials - balanced and into every room and each TV outlet at the proper level. If you plan to do multiple-outlet systems, start here with this Coop written tutorial. LtdQty and only \$10 per copy while they last! (SPACE discount)

## Nelson Parabolic Manual

The Nelson Parabolic TVRO Manual. If you are the type of person who wants to build your own dish (up to 3.7m in size), or, you simply want to understand why some dishes work better than others, this step-by-step "how to build a dish" manual is the "Bible" of an industry. Nelson Ethier was a perfectionist and brilliant with hand tools. It shows here - the ultimate backyard project! Half original price at \$15, LtdQty, SPACE discount applies.

## SPACE Pacific Order Form (also see SPECIAL PACKAGES on reverse side)

Please send the following:

SPACE Pacific Report - 9901-9904/ \$55 (no discount);  Shows 9905-9908/ \$60 (no discount);  Package deal - 9901-9908 (2 tapes)/ \$105 (no discount);  World Sat TV-'92/\$10;  TB 9404 - DTH Systems/\$10;  TB 9405 - SMATV Systems/\$10;  Nelson Parabolic TVRO Manual/\$15. Total of order - \$\_\_\_\_\_ . If current SPACE member, multiply by 0.7 (70%) and

write discounted total here: \$\_\_\_\_\_

I wish to pay this by  cheque (enclosed)  VISA card  Mastercard  
Card number \_\_\_\_\_ expires \_\_\_\_/\_\_\_\_

Ship to (name as it appears on card):

Company \_\_\_\_\_

Mailing address \_\_\_\_\_

Town/city \_\_\_\_\_

Your signature: \_\_\_\_\_



# SPACE Pacific Terrestrial TV Reference Materials

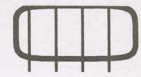
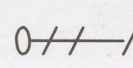
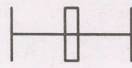
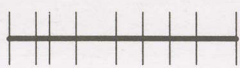

Each of these editions researched, created by "Coop" to help you solve tough aerial problems

<b>TB 9301</b>	<b>Tech Bulletin 9301. Co-Channel &amp; Antenna Phasing.</b> How to grow a single antenna (Yagi, broadband antenna) into a complex array to greatly increase gain, sharpen receiving pattern to eliminate co (same) channel interference. Totally hands-on, very practical, up-to-date. Go from novice to professional!
<b>TB 9302</b>	<b>Tech Bulletin 9302. Weak Signal Reception Techniques.</b> If one cut-to-channel (Yagi) antenna won't do the job, will 2, 4 or 8??? How about 16? Stacking antennas, mating with carefully selected masthead amps, is an art. This explains how to do it for professional results up to 300 km from TV stations.
<b>TB 9303</b>	<b>Tech Bulletin 9303. UHF - The Frontier.</b> Using parabolic style antennas surfaced with low-cost poultry mesh, build UHF dishes up to 40 feet in size to extend UHF off-air reception out to 300 km. And - learn the tricks to "squirt" signals from a hilltop to a valley below using low-cost receiving equipment.
<b>TB 9304</b>	<b>Tech Bulletin 9304. Beating Noise Interference &amp; Combining Cross-Pole Signals.</b> When TV and FM signals are weak, man-made interference from appliances, power lines can kill reception. Step-by-step instruction for identifying, locating, fixing noise sources + unique method of combining cross-pole TV signals.
<b>TB 9305</b>	<b>Tech Bulletin 9305. Cable Television - Fact &amp; Fiction.</b> The story of how a cable TV system is designed, built, operated. The perfect "So this is how it works!" report. Who knows - you might even like the concept so well you take out a mortgage on your home and wire your town!
<b>Lost Art</b>	<b>Lost Art of Rhombic Antennas -27 dB of gain VHF &amp; UHF.</b> Everything you need to know to build the most sensitive VHF-UHF receiving antenna ever created. Rhombics are used for virtually all long haul military circuits. Includes super-Rhombic LaPorte design. 300 km? A piece of cake!
<b>40' Dishes</b>	<b>20 to 40' Poultry Mesh (Chicken Wire) Parabolics.</b> Complete instructions to build UHF-TV off-air reception antenna system combines low cost reflector materials with Redwood or other durable "struts." 20 to 25 dB of gain, out to 300 km UHF reception. A backyard project with earnings potential.
<b>Half- Bolics</b>	<b>World-Famous Frias Half-Bolic Reflector.</b> Amazing design allows simultaneous reception over sizeable arc of transmission locations. City grade (80 dBuV) reception from distances of 280 km on VHF (45 MHz) through UHF (900 MHz). This is huge, but easily the best all-around deep-deep fringe antenna system.
<b>Raw Video</b>	<b>SPRSCS '99.</b> SPACE shot many hours of video during SPRSCS '99 to prepare for the (now available) 9901 - 9904 one-hour TV shows. In "Raw Video" you have everything shot, <u>before</u> editing, including material done by Robin Colquhoun for the Dr Overflow software explanation - all reshoots and mistakes! 4 hours, PAL.

## ORDER FORM - and special discount packages

Please send the following:

- TB 9301/\$10;  TB 9302/\$10;  TB 9303/\$10;  TB 9304/\$10;  TB 9305/\$10;  Lost Art-Rhombic/\$20;  20-40' Dishes/\$20;  Frias Half-Bolic/\$20 - or  
 TB9301/9302/9303/9304/9305 - \$40 -or-  Rhombic/ 20-40' Dishes/ Half Bolics - \$50 -or-  
 TB9301/9302/9303/9304/9305 + Rhombic/20-40' Dishes/Half Bolics - \$80.

**Video:**  Space Raw Video/\$35;  SPACE Videos - 9901-9908 + Raw Video/3 tapes \$135.

Total of order - \$ \_\_\_\_\_; If current SPACE member, multiply total by 0.7 to obtain discount price (NOTE: No discount applies to Raw Video or SPACE Pacific Report) - new discount total \$ \_\_\_\_\_. I wish to pay this by  Cheque (enclosed)  VISA  Mastercard

Card number \_\_\_\_\_ - \_\_\_\_\_ - \_\_\_\_\_ expires \_\_\_\_/\_\_\_\_

Ship to (name as it appears on card)

Company \_\_\_\_\_

Mailing address \_\_\_\_\_

Town/city \_\_\_\_\_

your signature \_\_\_\_\_

Return to: SPACE Pacific, PO Box 30, Mangonui, Far North, New Zealand or fax to 64-9-406-1083



# SatFACTS MONTHLY

ISSN 1174-0779

is published 12 times each year (on or about the 15th of each month) by Far North Cablevision, Ltd.

This publication is dedicated to the premise that as we enter the 21st century, ancient 20th century notions concerning borders and boundaries no longer define a person's horizon. In the air, all around you, are microwave signals carrying messages of entertainment, information and education.

These messages are available to anyone willing to install the appropriate receiving equipment and, where applicable, pay a monthly or annual fee to receive the content of these messages in the privacy of their own home. Welcome to the 21st century - a world without borders, a world without boundaries.

**Editor/Publisher**  
Robert B. Cooper (ZL4AAA)  
**Office Manager**  
Gay V. Cooper (ZL1GG)

#### Reaching SatFACTS

Tel: 64-9-406-0651  
Fax: 64-9-406-1083  
Mail: PO Box 330  
Mangonui, Far North  
New Zealand  
Email: Skyking@clear.net.nz  
<http://www.satfacts.kwikkopy.co.nz>

#### Subscription Rates

Within NZ: \$60 p/y  
Australia: AV-COMM Pty Ltd, PO Box  
225, Balgowlah, NSW 2093  
61-2-9949-7417  
Elsewhere: US\$60 p/y  
All copies sent via airmail fast post  
world-wide

#### ERRATA

SatFACTS Copyright 1999 by Robert B. Cooper; any form of copying is a violation of our international copyrights. Advertising rate sheet available upon request.

## COOP'S COMMENT

Indian television. We've previously reported that since May when AsiaSat 3 came on line, there has been a tremendous growth in free-to-air television originating in India, now quite easily received throughout Australia and to a lesser extent New Zealand. What began with As3 has grown to include additional FTA Indian channels on Thaicom and InSat 2E. Both satellites provide big signal, small dish coverage to the eastern Australian shoreline. But it is still C-band and even if the dish can be as small as 2.2 or 2.4m in size, that exceeds the legal size limit

in many locales. The real answer is to get the same sort of services onto Ku band, with sufficient power that smaller dishes that don't offend the neighbourhood will work. As no Ku band high power satellites are planned for Australian coverage - beyond the Optus series - we must accept that while C-band FTA is here and available, it will take Ku level signals to really create a commercial market for home dish systems. Those of us who cut our teeth and grew up with C-band have no objection to C-band size dishes - but the typical consumer and his neighbours find little that is attractive or desirable in C-size parabolic dishes.

There are several possible solutions - each requires a market of sufficient size to justify a business decision to repackage a "bouquet" of Indian channels from C-band up to Ku for redistribution on Optus. There are two technical possibilities here. First there is Mediasat which has demonstrated how an Optus service can provide relatively small dish coverage over Australia and New Zealand simultaneously. Their Optus B3, vertical, 12.336 coverage allows dishes 1m in size and smaller to produce high quality "dry air" coverage from eastern New Zealand west to Perth. Many expressed surprise that Optus had such a coverage pattern available. It turns out the same coverage might also be turned on for at least one or two of the present Aurora transponders as well. And Aurora is the second possible carrier for a bouquet of Indian services.

The original interest and commercial activity that followed the availability of Indian services on C-band AsiaSat 3 has subsided. What we have learned from that brief period is as follows:

(1) Ethnic groups will pay money for a satellite dish to receive their country of origin television; (2) Dish system price is a major factor in purchasing decisions, as a group these are bargain hungry people; (3) Dish size is a secondary factor but more important than most of us initially realised; (4) Reception 'quality' is secondary - and something you can play with on C-band analogue.

But will they pay money for a monthly subscription??? Nobody really knows the answer to that one. Will they trade improved reception with digital quality and smaller Ku-band dishes for a willingness to pay a monthly fee? The only model we have to study is Foxtel and Optus (cable). Both offer a limited number of ethnic services, some as low as \$10 per month per channel, and as best we can determine this has not been particularly successful.

Transferring C-band analogue services from InSat 2E, Thaicom and AsiaSat 3 to a bouquet of digital channels on an Optus transponder is a business enterprise. Which translates to a monthly fee - *there is no way around that*. Which places the enterprise squarely in the camp of TARBS - an ethnic version of Austar or Foxtel. Will people who are reluctant to pay money for a dish system be any more willing to pay a monthly subscription? More importantly, will enough ethnic viewers pay a monthly fee to create a profitable business? Without this, we are back to C-band, TARBS notwithstanding.

#### In Volume 6 ♦ Number 63

Hyundai HSS800ci product review -p. 6  
World of RF distribution (part two) -p. 10  
MadMax freed, immediately re-arrested -p. 15

#### Departments

Programmer/Programming Update -p.2; Hardware/Equipment Update -p. 4; SPACE Pacific Report (digital IRDs with SPACE Member discounts) - p. 20; SatFACTS Digital Watch -p. 24; Supplemental Digital Data -p. 26; SatFACTS Analogue Watch -p. 27; SPACE Pacific Report - TV Show schedule -p. 28; With The Observers -p. 29; At Sign-Off (dish pricing versus corporate overhead) -p. 32

#### -ON THE COVER-

*One monster chip + Irdeto and CI access equals the Hyundai HSS800ci (p. 6).*

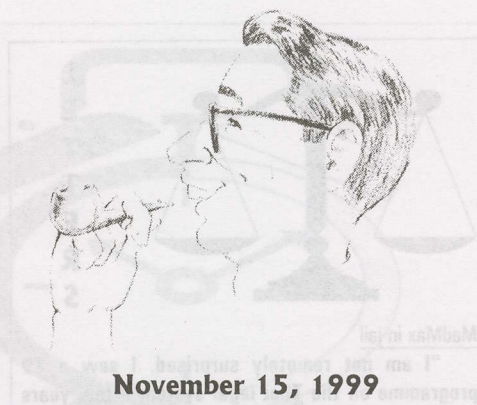

November 15, 1999



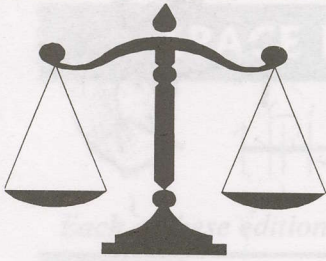

## LETTERS

### MadMax in jail

"I am not remotely surprised. I saw a TV programme on the Thai legal system a few years ago. I think if MM had have seen it, he wouldn't have gone there. I believe that MM belongs in jail, but not a Thai jail. Nobody belongs in a Thai jail. It is a pity Australia didn't have the laws, when he was here. Just because it is a white collar crime doesn't mean he should not be prosecuted. I guessed long ago that he would come unstuck, it was only a matter of time before Mindport would get him. Irdeto's loss of credibility as an encryption system could have cost them millions. That is why I was not impressed with your reporting of his activities earlier in the year; it almost read as if you were trying to encourage MM. However, SatFACTS October sets the record straight and from your Coop's Comments - I detect you are trying to assist him at least as far as finding him legal help. The fact that his 'friends' apparently failed to come to his aid does not say much for the culture that he lives in."

A.I., Queensland

### Black Spot follow-on

"Regarding your SF June (p. 18) and October (p. 32) reports on the problems of terrestrial TV reception in Tasmania. These articles highlight the problems I have had with Black Spots and I am still involved in the sales of both terrestrial and satellite television reception equipment in Southern Tasmania, May I have permission to photocopy and fax these pages to the office of David Llewelan, MHA? This information will go a long way to bring to the attention of our elected Parliamentary representatives the problems associated with inadequate television reception in our state. Thank you for the work you do producing a most informative publication."

Arthur Blackwell, Electronics Country, Brighton, Tas.

Permission granted of course. What is needed, however, is more Black Spot publicity in local, regional, state newspapers to focus the public's attention on the options they have here. If terrestrial analogue reception is poor, future terrestrial digital won't work - at all!

Politicians respond to public outcry - very little else.

### Where is the enthusiasm?

"Placing **SPACE Pacific Report** on Westlink (Aurora ch. 23 - ed.) is magnificent. Now thousands of new viewers including school users will be exposed to the excitement and technology of our industry. Still remember my first look at Sat TV in early 80s - when ABC was tested on C-band Intelsat in NTSC to typically 18' square mesh dishes in rural Australia. Show 9906 (Uplink Visit - part 1) had me riveted to my chair - well done! Do you still have the same drive and enthusiasm?"

Alek Zapara, WA

At 61, nothing works the same!

## PROGRAMMER PROGRAMMING PROMOTION

## UPDATE

November 15, 1999

**TV black spots.** First 700 returns from Tasmanian MHR Sid Sidebottom (SF October, p. 32) pinpoints regions of the island state where TV, mobile telephone, radio work very poorly if at all. 20% of reports saying they had poor or no service originated in Circular Head region, 18% from Ulverstone, Forth, Turners Beach, Gunns Plains and Penguin. Next challenge - to translate the findings into a master plan to correct the lack of terrestrial coverage.

**Celebration.** 2000 is - amongst other things - 75th anniversary of Royal Australian Corps of Signals.

**AsiaSat 2** will be trans-Indian Ocean carrier for major coverage of 2000 Summer Olympics. European Broadcast Union (EBU) has signed agreement for two (C-band) transponders which will relay event coverage through Cyprus for transfer to national TV networks in Europe.

**SES**, operator of European Astra satellite platforms, will establish Hong Kong "multimedia" service during next year. Astra has capacity to directly download to home and business PCs multimedia content; Astra-Net through Hong Kong will extend that service into Pacific and Asia. Applications include IP Multicast Package Delivery and Streaming applications and high speed Internet. No word on which AsiaSat satellite at this time but 3 seems a probable choice. SES is a major investor in AsiaSat.

**CNN, BBC** and virtually every other international and national network will pre-empt regular programming over Millennium transition. CNN plans 100 hours of special coverage, launching in New Zealand (Mike Chinoy from Gisborne), as world turns itself into a new man-designated century. 100 hour coverage will feature 50 "major reports reviewing cultural issues that have affected or changed the course of history during last 1,000 years."

**And then their dish fell over.** CNBC's UPS safety net collapsed October 27 forcing them to use, directly, the local power grid. The UPS gear protects them from local power surges - a not infrequent problem in Singapore. Sure enough, while on local mains, a new surge October 29 knocked them off the air. Then on October 30th as they were switching from local mains back to a repaired UPS, a new 'spike' corrupting their digital data stream to PAS-2 and shutting them down. And *you* want to be an uplink operator???

**Telstra redirection** for Big Pond. The big guy is rolling out massive PR campaign late in November, touring all of Australia with show business style "party" to introduce PAS-2 Ku downlinked Big Pond. Prices are dropping from \$1,600 install to \$262, monthly fees as low as \$35. This is a "rental" arrangement - customer does not own dish. And the signal - tired of not having enough oomph, on December 3 at 7AM AEST, frequency change from 12.294 to 12.281, increasing downlink power by reported 3 dB (SR 27.500, FEC 2/3 stays the same); see p. 32 here.

**Malaysian company** planning 8 channel pay-TV package off of PAS-8 Ku into Australia? That's the rumour. HBO said to be included.

**Austar**, not supposed to be servicing motels, hotels with movie channels in Tasmania, is "cheating." And Optus, which claims the negotiated right to do so, is the loser. Optus installation rates have skyrocketed out of control, leaving Austar with the bulk of the commercial business there. MDS service by Austar in Tasmania has significant problems, combination of terrain and 2 GHz region long haul telephone microwave which beats with and overloads poor selectivity MDS antenna mounted down converters. There are technical problems here begging a solution.



## DX Antenna DSA-646EIIA Receivers

Professional rack mount C/Ku band satellite receivers. Brand new, 40 units, A\$100 each, freight collect ex-Sydney. Also available - identical units in used condition at A\$50 each.

John Martin, ++61-2-9281-4481, Fax ++61-2-9212-4464, e-mail: [jmartin@compuserve.com](mailto:jmartin@compuserve.com)

## PACE IRD50 Analog Cryptovision Receivers

Remanufactured, fully tested, serviced. On-screen display, SCART outputs, remote control, C/Ku bands, UHF modulator, 920-2050 L-band, 14/18V polarity switching, 27 MHz IF bandwidth. A\$75 each, two for \$125 w/remotes and (untested) Ku LNBF (+ freight).

See [www.actec.com.au/ird50.html](http://www.actec.com.au/ird50.html).

Winersat SMATV/MATV/CATV products? In stock!

### Advanced Circuit Technology

contact fax ++61-3-352-772-161 or email [actec@bigpond.com.au](mailto:actec@bigpond.com.au)

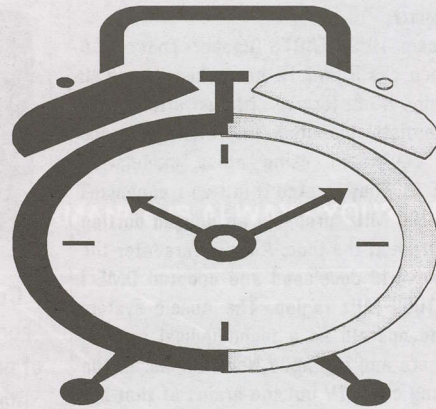

## SPRSCS '00? March 2000

Where would you like  
this year's annual  
SPACE Conference  
to be held?

Vote for ONE of the following:

#1 - Victoria, #2 - Norfolk Island, #3 - New Zealand

Vote by Email to [Skyking@clear.net.nz](mailto:Skyking@clear.net.nz) or fax to

+ +64-9-406-1083 or by mail to PO Box 30,

Mangonui, Far North, New Zealand

**SPACE Pacific Report - now broadcast Optus B3 SIX times each week - schedule page 28.**

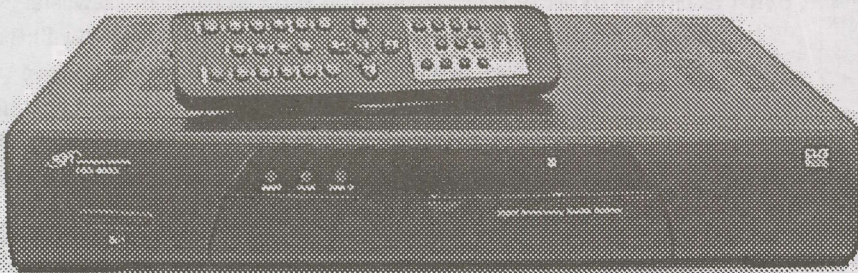

## New Hyundai HSS800ci

Works on Irdeto CA services, and FTA DVB, PowerVu, in both NTSC and PAL!

- ◆ 1300+ channels Video and Audio
- ◆ 2 x CI slots for 6 types of conditional access modules.
- ◆ Irdeto, Viacces, Conax, Cryptoworks, Nagravision and Mediaguard
- ◆ Conversion to PAL or NTSC at the output, menu selectable
- ◆ Editable channel name, satellite name and Video, Audio and PCR PIDs
- ◆ Works on Aurora and Austar (with CI module and authorised card) as well as FTA services from Apstar 2R, Thaicom 3, Pas2, Pas8, and the MediaSat bouquet on Optus B3
- ◆ MCPC-SCPC 2-45Ms/sec coverage
- ◆ Switchmode power supply 90-260VAC 50/60Hz
- ◆ RCA Video and Audio output sockets as well as SCART. Video available in Composite, RGB or Y/C
- ◆ Cost \$690 plus tax. Call for wholesale or export prices CI Irdeto module \$150ea. Sold only with the receiver.

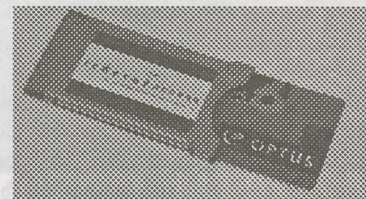

### Irdeto CI module.

Picture for illustration purposes.  
Card is inserted chip facing upwards for correct operation

**KRISTAL**  
electronics

25 Cataract Ave,  
Rangewood QLD  
4817. AUSTRALIA.

Tel. 61 (0)7 47888902

Fax. 61 (0)7 47888906

[www.kristal.com.au](http://www.kristal.com.au)

[kristal@ultra.net.au](mailto:kristal@ultra.net.au)



## Silly 6 megahertz

"Reference p. 10 SatFACTS October. That silly 6 MHz between chs 9 and 10 has a history which might explain - if not forgive - it. Just after WW2, Aussie scientists invented Aircraft Distance Measuring Equipment using pulse modulation (called DME A). They located it in two frequencies just above 200 MHz, probably an unused portion of the spectrum at the time. A few years later the rest of the world developed and adopted DME I using the 1000 MHz region. The Aussie system continued to operate as a technological orphan, used only here and in Papua New Guinea. In the mid-50s along came TV but the brains of that era decided DME A would stay where it was and TV channels would be allocated around it. Hence the silly (6 MHz) gap between Australian Ch 9 and 10. In the early 90s, Australia caught up with the rest of the world adopting DME I and shutting down the A version. However, unlike SatFACTS' suggestion, nobody else has been game enough to suggest 'sliding' the existing channel allocations 1 MHz up to create 7 MHz of space where the (now) unused 6 MHz is sitting; typical of the 'rocket scientist' approach running this country's TV system. This may happen to explain the existence of a 6 MHz hole in the middle of the TV band, but not excuse it. I happen to know a bit about the DME A, being a grey-haired old QANTAS Captain who has been around the block a few times. And I now play around with satellite TV as a hobby. Keep up the good work with SatFACTS!"

Bill Scott via email

No TV set ever sold in Australia would have any difficulty coping with a 1 MHz upward shift for channels 10 and 11 and with the introduction of digital (DVB-T), Australia certainly could use a brand new 7 MHz wide VHF TV channel!

RF distribution-

"The article on RF distribution (SF October) was something I feel should have been done long ago; perhaps a book with detailed step by step instructions now with the advent of so many channels? People, particularly motel and high rise owners, have to come to grips with the fact that an antenna on the roof followed by an amplifier no longer constitutes an adequate TV distribution system."

Brian Watson, Western Video Pty. Ltd., Tasmania  
Appreciate Mediasat distribution

"A short note to let you know I enjoyed finally seeing an episode of SPACE Pacific Report. Due to site limitations I was unable to receive KIBC. I was particularly impressed to see the discussion of the Dr Overflow software and by coincidence had met presenter Robin Colquhoun only weeks ago when he was visiting at Av-Comm. My only complaint is there is but one Sunday a week and hence only one show each week!"

Steve Sharp via email

Ah yes - but now with the three day a week showing on Westlink (Optus B3, Vt, channel 23 inside of Aurora) you have six showings per week, slightly staggered in "episode."

"Can SPR revisit the Nokia Dr Overflow and explain the software blockers?"

Hal, via email

Only if MadMax agrees to present it.

## HARDWARE EQUIPMENT PARTS

## UPDATE

November 15, 1999

**Confused pricing.** Distributor for UEC 660 IRD quoting A\$690 over telephone, "correcting" invoicing to \$720 when order is placed. Payment terms nominally "31st of next month" are hand modified to read "cash on UEC products" as well. Aurora Smart Card for 642/660 remain A\$50 but is only available with companion receivers.

**Plastic LNBFs.** New challenge for NZ Sky installers - LNBFs that refuse to stay put. New plastic-cased models have twin clamping screws to hold unit in position after peaking for best signal and cross-pole null. Unfortunately, plastic is "elastic" and entire assembly shifts when (1) connecting up downline, (2) place drip loop in downline, (3) try to seal the F connector. No, you cannot tighten up the clamp screws sufficiently to eliminate elasticity of assembly. Ahh yes - but they cost Sky less money!

**Australia has awoken** to the HDTV "fiasco" panic now sweeping the USA, opposition to a mandatory HDTV digital format is building. Excellent review of issues found at <http://www.pc.gov.au> which is Australian Productivity Commission site. Once there, go to (1) Publication, (2) Recent publications, (3) Draft report / Broadcasting, (4) Chapter 6 - "Road to Digital Television." Amongst summaries - "HDTV ...lower quality in marginal reception areas because there is less error correction than with standard definition." And, "stipulating features must be weighed against increased costs of design and production for Australia's small market." Bottom line - Australia and only Australia in entire world plans HDTV using COFDM modulation, Australia and only Australia has specified Dolby AC-3 audio as a part of DVB-T resulting in DVB-T receivers costing 150-170% as much as elsewhere.

"Upgrade of (power supply) components" is official explanation. Sky Channel is retrofitting all UEC 660 receivers - 5,000 +? - with zener diode and "resistive components" after discovering very high failure rate at TABs throughout Australia. It has been called the 'Cricket' malady because IRDs shut down, display quits, and receiver sits there making a 'chirping' noise. Systematic repair of TAB sites involves full replacement of 660 power supply boards.

**ADB & SMS** boxes for Austar in Australia - have topped 150,000 to date in 1999. Which means there are another 170,000 DGT400s still in use.

**Co-operation.** Most of us believe the distributors who work in this business don't talk to or like each other. Not always the case - example. Philip Ingegneri of Kristal Electronics while testing prototype of Hyundai HSS800CI (see p. 6 here) badly needed a particular Irdeto CAM to determine if IRD would perform with Aurora, pay-TV services. He found one and willing loan of same from Peter Merrett at Sciteq. And he was grateful enough to ask us to mention his gratitude towards Peter.

**LNBFs** for new French I701. Most European "Universal" LNBFs will work - with a 11.610 downlink, you need a 9.750 LO (resulting in 1860 L-band) - no, 10.750 won't work (unless you have an L-band IRD that will tune down to 860 MHz!).

**Dish prices?** Where does Ericsson, supplier of hardware to Telstra Big Pond, get their dish pricing? If consumer buys (rather than rents) dish, a 65cm system in a residential / city area is \$1,326 but escalates to \$2,207 for remote locations. Hold on - it gets better. The 85cm goes up to \$1,349 (a \$23 premium which makes sense). But a 1.2M? waaay up to \$2,319 and a 1.5m rockets to \$3,441! The REAL price difference at distributor level between 65cm and 1.5m is around \$100 - which after Ericsson processes it ends up at \$2,115. Sure it costs more to ship, slightly more to install. But \$2,115??? Pity the rural 1.5m user - it jumps to \$4,568. If you apply the same formula to a 3m (C-band), they would be \$9,455 in rural areas!



# ADL<sup>®</sup>

BECAUSE PERFORMANCE IS ALWAYS YOUR FIRST PRIORITY

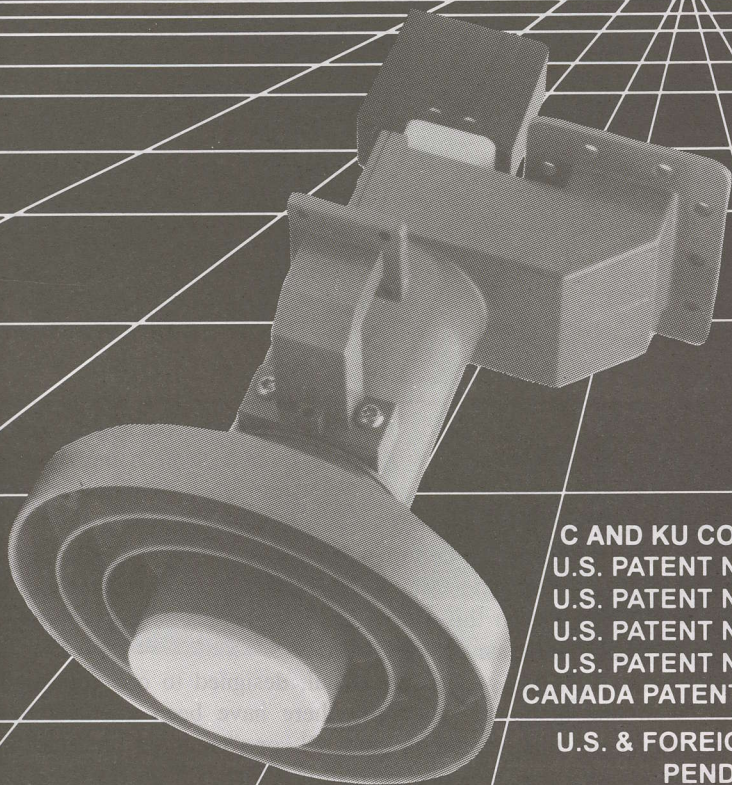

**RP3-CKU/ International  
Adjustable Scalar Ring Feed  
with Extended C Band**

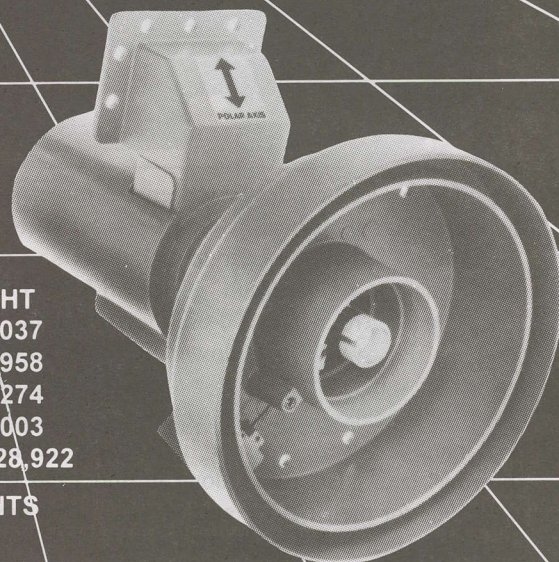

**RPI-CKU Feed**

**C AND KU CO-BORSIGHT  
U.S. PATENT NO. 4,903,037  
U.S. PATENT NO. 5,066,958  
U.S. PATENT NO. 5,107,274  
U.S. PATENT NO. 5,255,003  
CANADA PATENT NO. 1,328,922**

**U.S. & FOREIGN PATENTS  
PENDING**

## **ADL HYBRID MODING CIRCULAR POLARIZED INTELSAT FEEDS WITH EXCLUSIVE T.I. REJECTION**



**RP1-CP400**



**CP-300**



**CPOR-100**

- C BAND LINEAR & CIRCULAR • C/KU LINEAR & CIRCULAR • KU 12 GHz FEEDS
- INTELSAT 4 GHz CIRCULAR • ARABSAT S BAND FEEDS
- OPTIONAL: CO-BORSIGHT S BAND

2216 AGATE COURT, UNIT B, SIMI VALLEY, CALIFORNIA 93065 • (805) 526-5249 • FAX (805) 584-0634

**NEW ADL Web site - [www.adlfeed.com](http://www.adlfeed.com)**



## The Hyundai HSS800CI

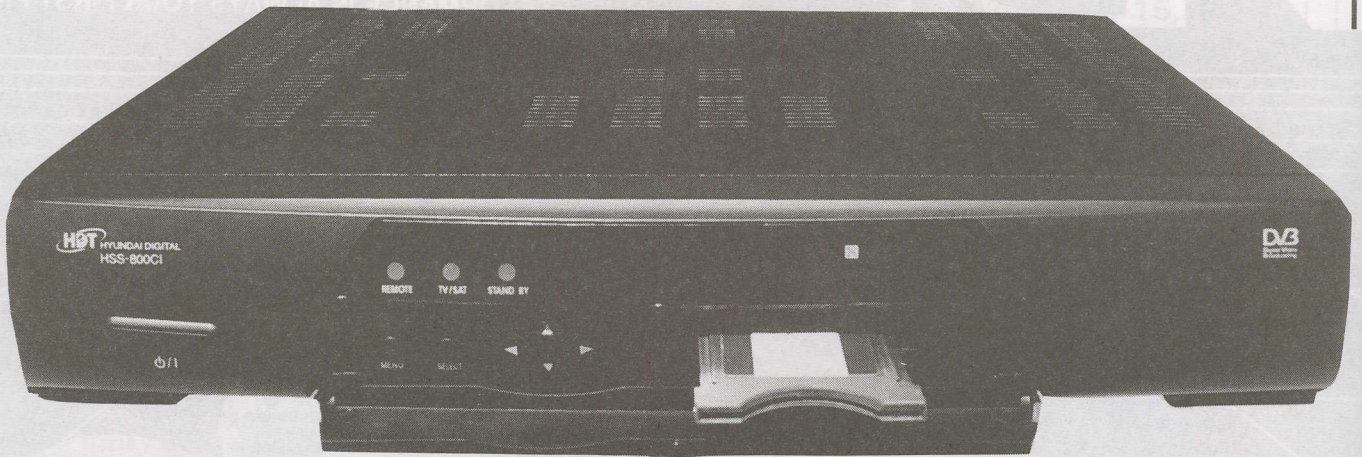

Sometimes as an industry we tend to forget just how young this entire digital business is. Some perspective:

The very first consumer style digital IRDs were Panasat 520 units snuck in from South Africa. *When?* February-March 1996. *Price?* Around A\$750 but they would not handle SCPC services, ran hot, shut down without warning and had insensitive tuners. Pace DGT-400s designed for the Australian (Ku band) Galaxy service were available, usually refusing to do C-band and were thus not "interesting." Even if you could "borrow" one. NBC came along in mid 1996 with Pace built DVR500s for their CATV and SMATV affiliates - essentially DGT-400s that had been software modified to work properly on C-band. And Scientific-Atlanta in June 1996 promised they would release D9223 "DVB Compliant receivers" at such time as "DVB compliant transmissions exist," a most unusual (well - not for SA) statement given that in *April* 1996 the European Bouquet had launched with what we know regard to be the benchmark DVB Compliant bouquet. It would be more than a year before SA "allowed" DVB software into D9223 units, for A\$500+ on top of an already expensive price-tag.

Comes now the Hyundai HSS800CI, a receiver that should attract plenty of interest in Australia. Why you ask? Because here, we believe for the first time, is an IRD that will hold two separate smart cards, allow you to seamlessly switch between services that require different cards, to switch with equal ease from Ku to C-band, from DVB Compliant to the selfishly promoted SA PowerVu format, and from NTSC to PAL. Best of all - it works exactly as promised and early reports from stand-in-line-to-have-one-first buyers tell us it is a hit. Moreover, it has a quite reasonable price tag (how much? Ask the distributor but certainly less than the original Panasonic 520s in 1996!).

In the pay-TV satellite game, being DVB compliant is secondary to having a unique IRD which discourages competition for viewers and at least on the surface retards attempts for piracy of programming. Foxtel/Foxsat, Sky NZ, Austar don't really want an IRD which is even capable of receiving other bouquets. Why? To slow down any late

starting competition to their programming packages. For example, Television New Zealand, blocked from being a part of the Sky NZ digital bouquet, wants to launch its own service. Putting it on satellite makes some sense because within another year 10% of all NZ homes will have a Sky dish, LNBF and Sky IRD. What better way to "launch" than to have somebody else - Sky NZ in this case - already in place with receiving hardware for the new (TVNZ) service?

So IRDs are service-functional, designed to operate only with one bouquet. Naturally there have been attempts to overcome this limitation and CI or "common interface" conditional access is one such effort. The "CI" in HSS800CI stands for common interface.

Common Interface means that either with a slide in CAM (conditional access module) or one hard wired (embedded) into the receiver, a range of smart cards (and conditional access software routines) can be accommodated. The 800CI will function with Viaccess (a French system), Cryptoworks and Conax (European), Nagravision (European and North American) and Irdeto. It is the latter that is of interest to Australians. Irdeto is to conditional access what PowerVu is to

Smart cards are stacked - one above the other in this HSS800CI configuration. In top slot - Irdeto CAM. Bottom slot - CI or common interface embedded slot.

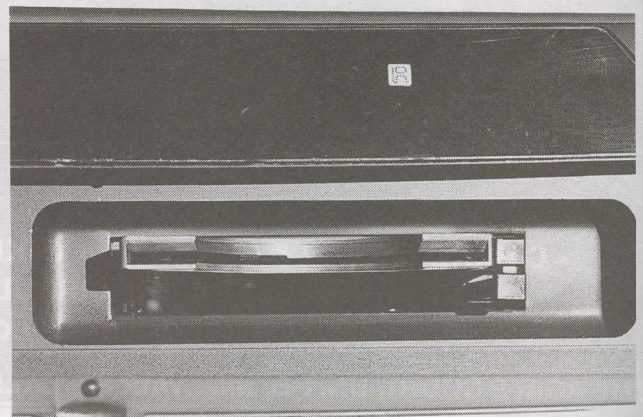



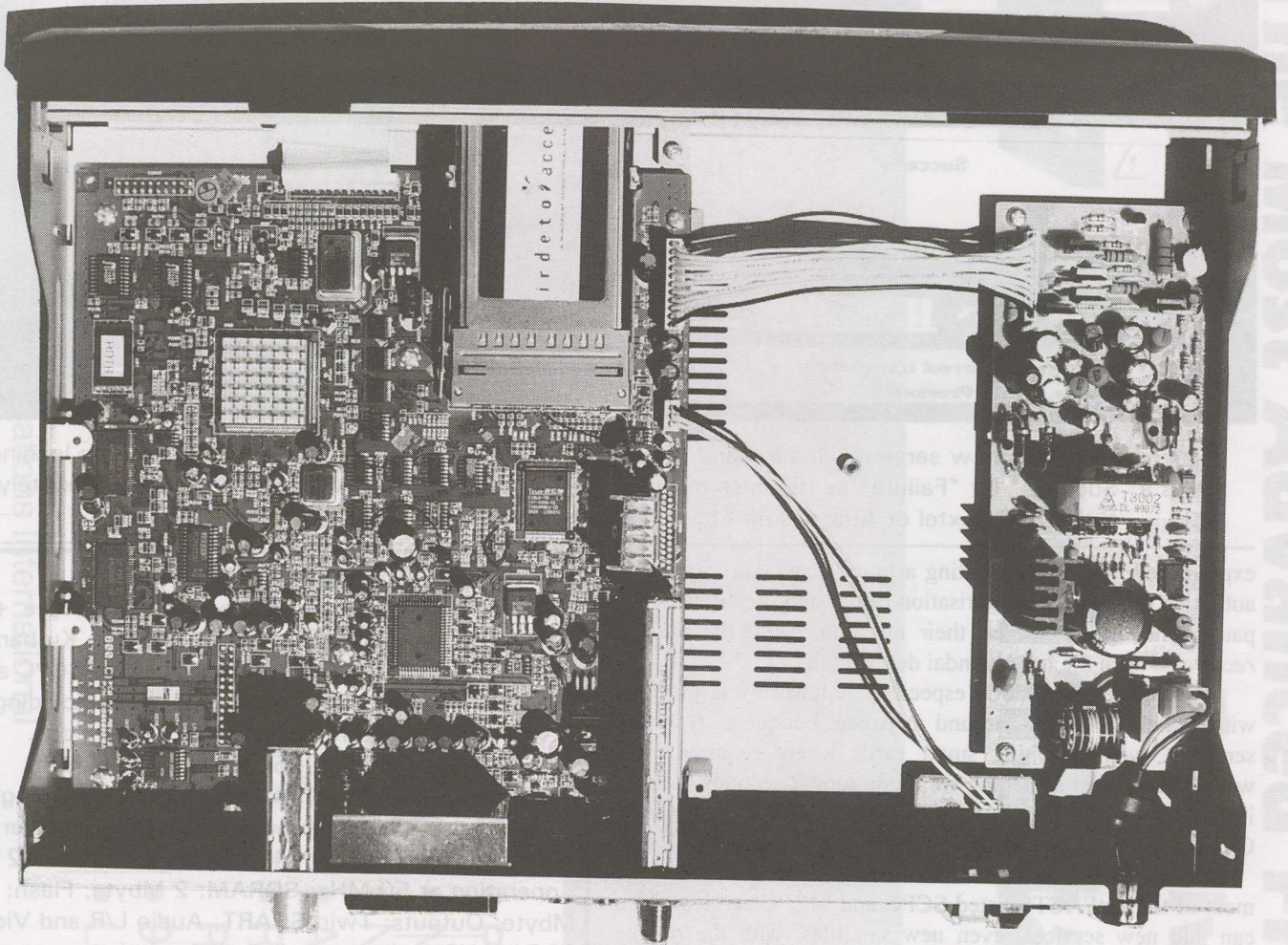

Hybrid. A cross between single chipper designs (such as Nokia 9800S - see p. 23, here) and the previous multi-chip designs, the Hyundai HSS800CI has as much "component parts count" handling the CI/CA processing (right hand half of main board) as it does performing all MPEG-2 processing functions (left hand side main board). And there's room left over to park a Honda car inside the cabinet!

DVB Compliant. It is *not* standard, follows its own rules, makes no effort to be "universal" nor to co-operate with other CA suppliers. Which is why we have two separate slots in the 800CI - one is for the CI CAM that everyone else uses and the

second can be used for an Irdeto CAM. Or, if you live in Australia, you can use both slots for Irdeto CAMs. We have checked this IRD out on all of the Australian pay-TV services (with a proper card it works fine) and on Aurora. In fact, we

When selecting a memory-loaded bouquet or SCPC service, the 800CI already knows the parameters (such as Middle East bouquet on PAS-2 3778Hz - which brings up RAI International - right, below).

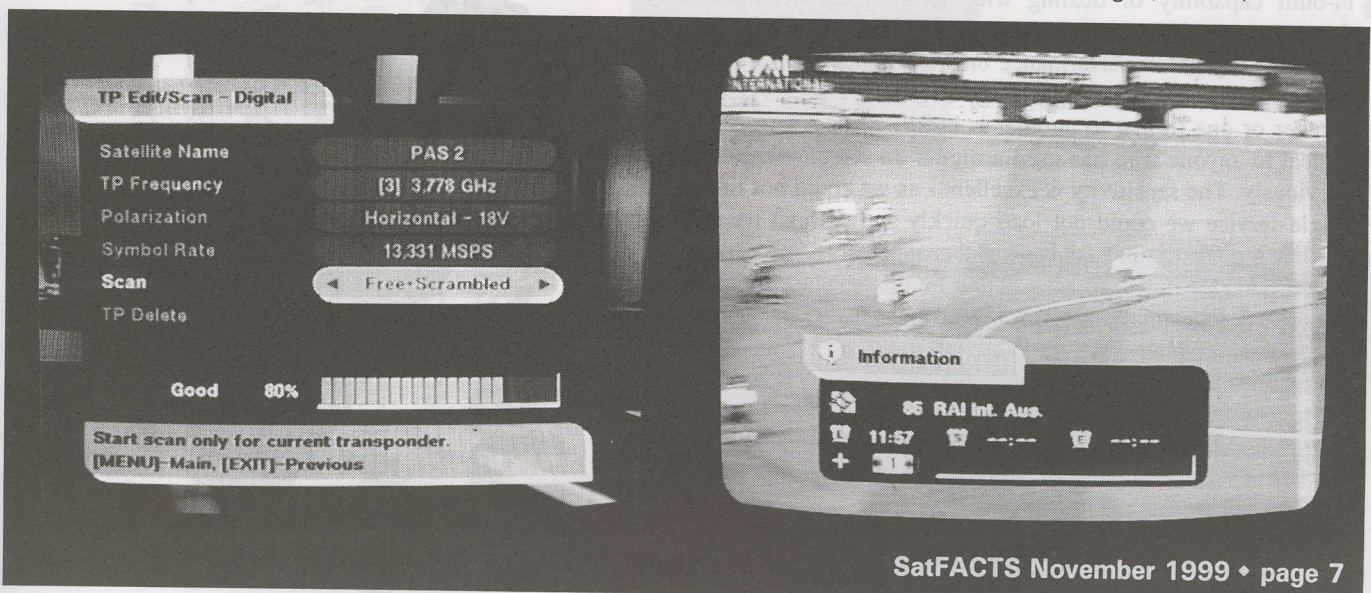



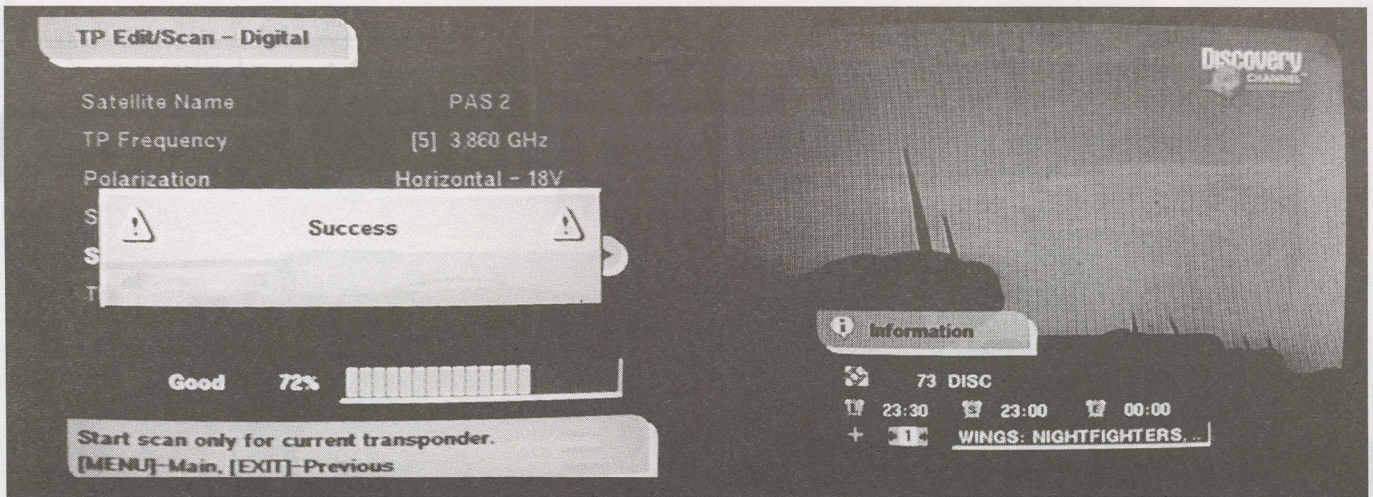

Nice touch. When new service is loaded and scanned, on screen advisory pops up telling you the loading was a "Success" (or "Failure" as the case may be). Right - With Irdeto CAM installed and appropriately authorised Foxtel or Austar smart card, up comes pay-TV services. Yes, Aurora as well.

experienced no problem getting a brand new Aurora card to authorise through the authorisation centre and they didn't even pause when we answered their question, "And the type of receiver?" with the full Hyundai description.

What makes the 800CI especially noteworthy is the ease with which it moves around between bouquets, types of services, even switching smart cards where required. The worst and slowest switching we found took 2 seconds (Aurora in one Irdeto CAM to a pay-TV service in a second Irdeto CAM). Normally, switching is split-second instant.

The 800CI comes out of the factory carton ready to load most of the SatFACTS listed SCPC and MCPC services. You can add new services, even new satellites, with the remote control keys, select NTSC or PAL output conversion, store more than 1,300 separate video (and audio) memory channels. Performance? Mediasat's TRT - no problem, of course. Yes - although we didn't need it for Mediasat, you can enter PID/PCR numbers for especially stubborn services. We located our standard list of "tough to load" SCPC and MCPC services and each of them (such as the PAS-2 Middle East bouquet on 3778Hz, 10 Australia service on I701 at 3765R, Miracle Net on JcSat3 at 3990Vt) promptly loaded. Even the ESPN PAS-2 PowerVu encrypted feeds loaded and played the audio side without encryption (3860Vt).

Most people will want this particular IRD because it has an in-built capability of dealing with virtually all of the CA formats currently around. It would be a mistake to overlook the really top notch performance on C-band, however. As the menu use screens here suggest, getting from one service to another or one format to another is both straight forward and logical to anyone who has used a digital on-screen-menu IRD previously. The sensitivity is excellent - as we could not find a single service we could not load quickly and without try and retry, it is difficult to rate it beyond that statement. And while a read of the above-average Instruction Manual is not a bad idea (otherwise you might miss some of the features such as Composite, RGB or Y/C video outputs), we had no difficulty or anxious moments simply taking it out of the box, connecting up the cables and pushing go. On a scale of 10, this is an 11. Suggestions? One very minor one. The battery weight in the hand held remote creates an awkward "balance point" which takes some getting used to.

### The Hyundai HSS800CI

A twin-smart-card capable common interface + Irdeto conditional access functional C + Ku band IRD that delivers brilliant performance on SCPC and MCPC bouquets, regardless of format including PowerVu and NTSC and all FTA services.

Frequency range: 950 to 2150 MHz; LNB switching: 14/18V, 22 kHz, 0/12V; Input: Single input with RF loop through for second receiver; Msym range: 2 through 45 Msps; Processor: 32 bit operating at 50 MHz; SDRAM: 2 Mbyte; Flash: 1 Mbyte; Outputs: Twin SCART, Audio L/R and Video RCA; LNB probe control: (polariser) skew control; RF modulator: PAL G/I/K adjustable 470-860 MHz; Operating voltage: 100 - 250V, 47-63 hertz, 30 watts max.

Source: Kristal Electronics, tel +61-7-4788 8902, fax +61-7-4788 8906; e-mail kristal@ultra.net.au and Web site www.kristal.com.au.





# The Most Advanced Free To Air Digital Satellite Receiver

## D7-MediaStar

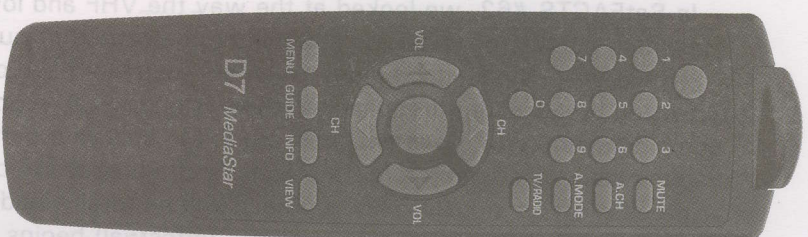
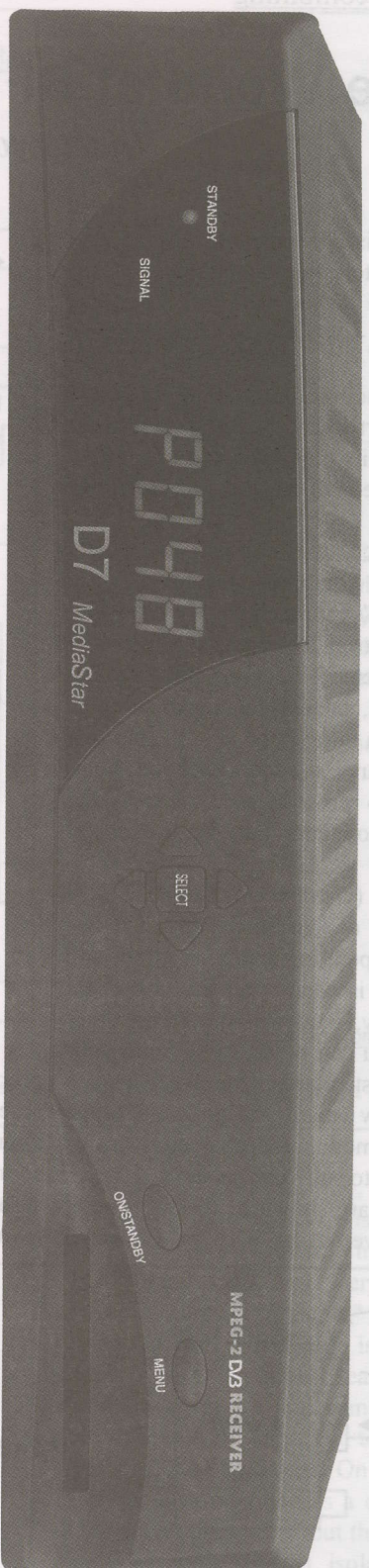

- MCPC/SCPC 2-36 Msym
- Direct channel selection from channel list
- Channel Edit menu Delete, Skip, ON.
- Fast response when changing channels
- No channel over-write
- 200 Video 100 Audio channels
- Automatic search and download
- 22 KHz switch
- PID Menu
- NTSC/PAL Auto switching NO NTSC Glitch
- NTSC converted to PAL-60Hz Free Option
- Audio L, R, Stereo selectable via remote control
- RF Modulator PAL-G, VCR/TV Scarts, RCA Audio/Video, SVHS outputs.
- 90-265VAC-50-60Hz power supply
- Low threshold performance



MediaStar Communications International  
24 Bosci Road  
Ingleburn NSW 2565 Australia

E-mail [opac@bigpond.com](mailto:opac@bigpond.com)  
Tel ++61 2 9618 5777  
Fax ++61 2 9618 5077



# The World of RF Distribution

## (part two)

A letter appearing in this issue suggests, "It is time commercial facilities such as motels found out that it is no longer adequate to stick an aerial on the roof and dump the output into a broadband amplifier - as a means of distributing TV signal to TV sets." A-men.

Actually, except in very small facilities with 30 or fewer TV sets, it never was the best or correct or properly engineered way to distribute TV. But old habits died hard and this one is going to cost millions (no - hundreds of millions) of dollars to kill and then correct.

The amazing truth is that processing multiple TV signals with separate (for each channel) equipment is only slightly more costly than the "broadband" approach. It is a rare day when five or six or seven terrestrial TV signals arrive at a receiving site with *identical* characteristics (same signal levels, same visual to aural carrier levels, same video signal to noise ratios). It is an even less common thing to be able to slap in a modulator on an unused TV channel at such a location, hook up an external video and audio programme source to the modulator, and then dump the modulator into the broadband system - without major problems.

As we illustrated in part one (October 15 SatFACTS), a coaxial cable network is a piece of "virgin territory." It has nothing inside of it, there is no operating spectrum at all, and what you create and feed into it is what receivers connected will receive. If installed properly, they will detect no other signals at all. And this means you can be creative, build your own channel list, shift away from standard channels (as long as the TV sets connected can follow where you go), and adjust the video and audio carrier and modulation characteristics of each channel inside of the system to suit your needs.

The sources for input signals are shown to the right here; off-air UHF (which can be converted to VHF in a channel

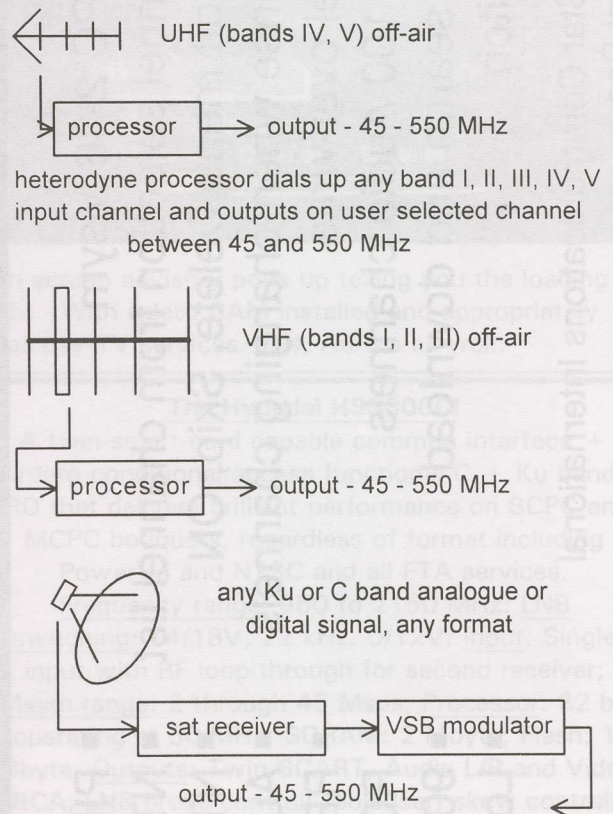

processor), VHF off-air, and modulators fed from satellite receivers (digital or analogue), tape decks, even PCs with appropriate software. Moreover, you can mix audio and video sources - video from a PC, audio from a radio station or off of a satellite radio or audio channel. Your limitations are your own skills - only.

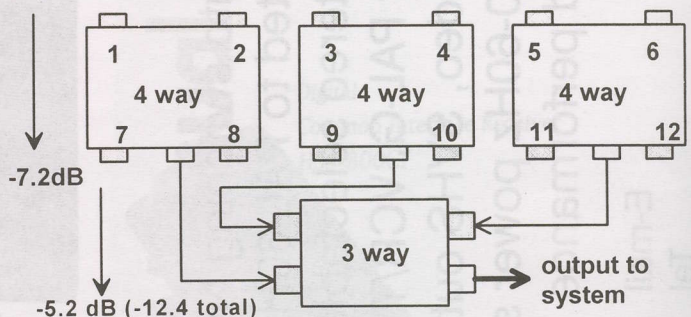
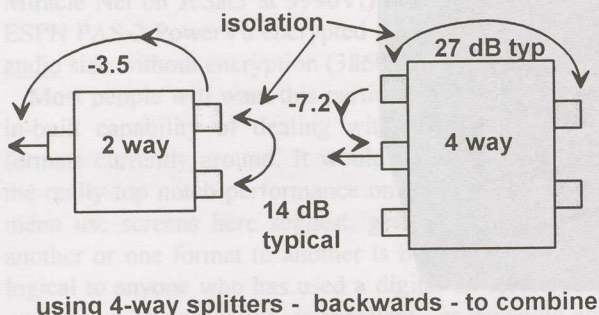

In SatFACTS #62, we looked at the way the VHF and lower UHF spectrums are partitioned to allow a maximum number of television channels to be carried through coaxial cable networks. And we learned that while various political regions (such as Australia) have created their own (unique) over-the-air set of television broadcasting frequencies, there is no logical reason to treat those channels as "mandatory" when equipment exists to move channels around to suit your particular need. Most to-date television distribution systems have relied upon a rooftop aerial and a broadband or set of "single channel" amplifiers to "headend" process off-air signals. This approach will be totally inadequate as DVB-T (digital video broadcasting - terrestrial) begins world-wide. To paraphrase a cartoon character,



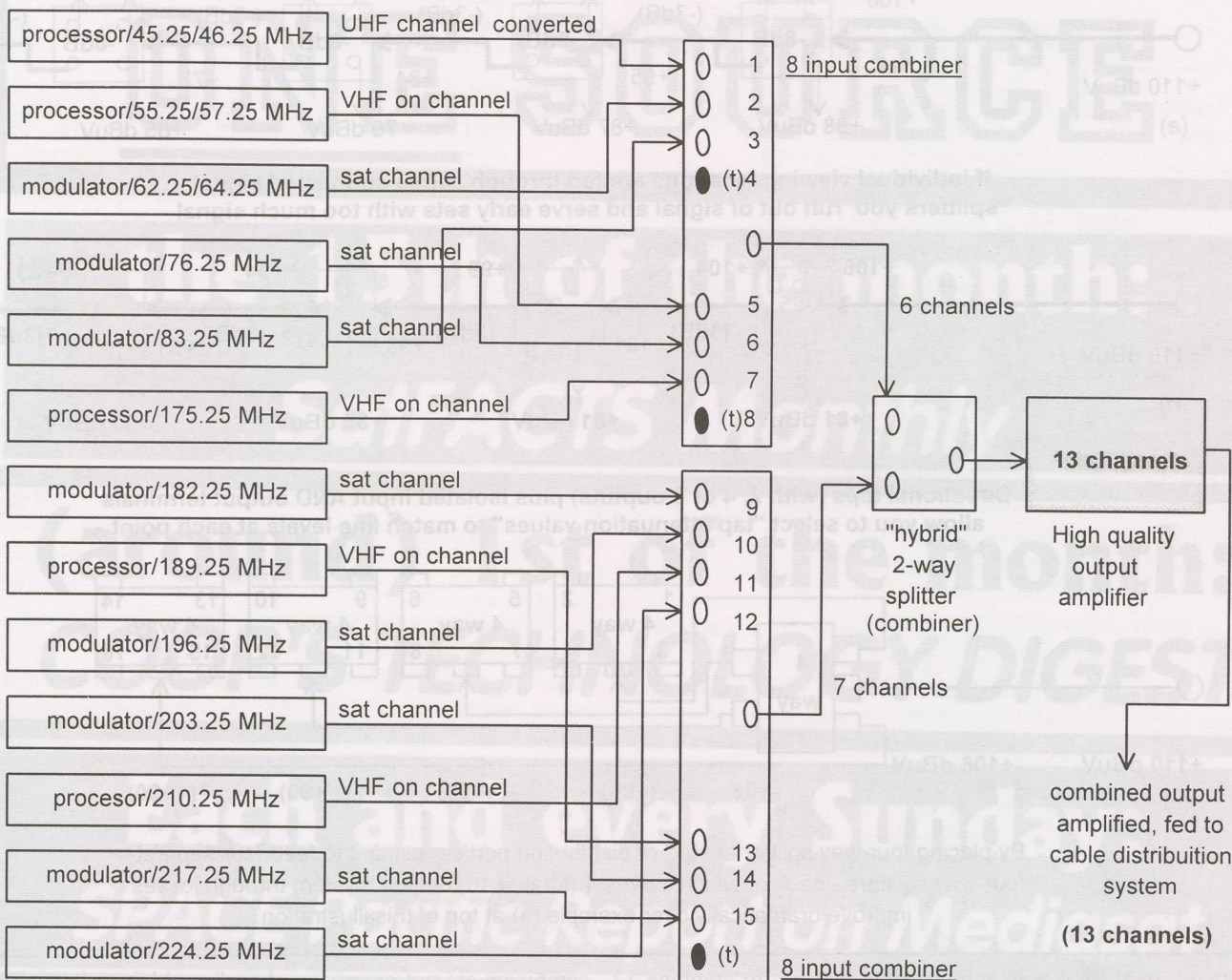

note: unused combiner inputs are "terminated" with 75 ohm resistor

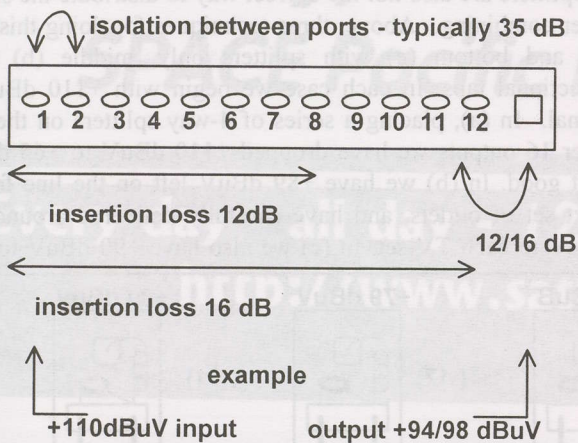

#### Assembling a spectrum -

A splitter (2-way, 3-way, 4-way, 8-way) can be wired up "backwards" so that what is normally the input becomes a single line output while the multiple outputs change to inputs. This is one quick, but not very good quality way to put two or more TV channels "together" into the same cable network. The reason why this is not good is "isolation" - a signal applied to one output (as an input) leaks or crosses over to the other output(s) - inputs - and some of it thereby feeds not to the newly designated output but to the equipment connected to the other output - input legs. On page 10, bottom, we see that a 2-way splitter operated as a combiner will typically have 3.7 dB of "combining loss" but the two outputs used as combining inputs are only 14 dB isolated from one another. And a

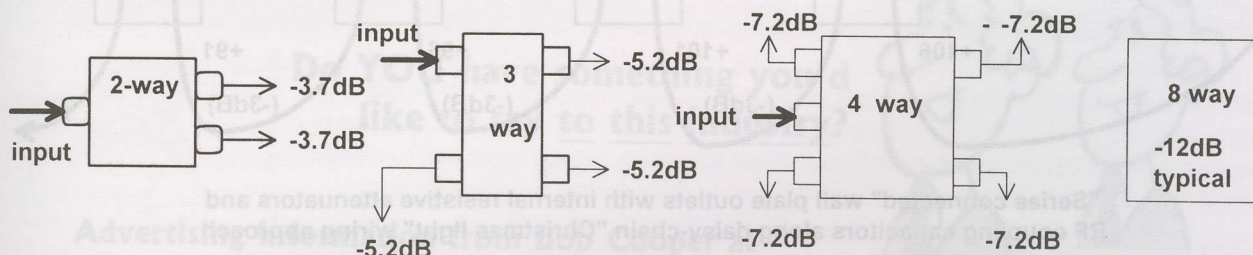

Basic "splitter loss" parameters - nominal



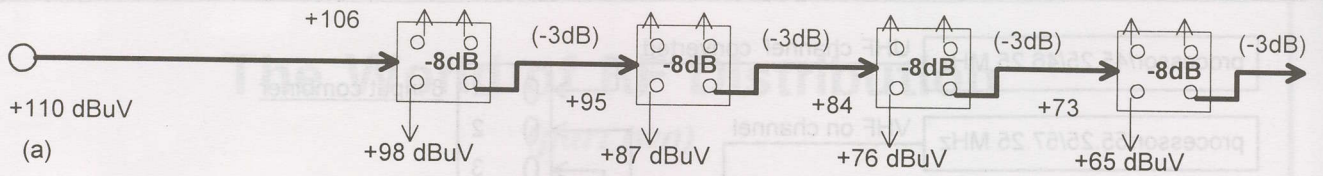

If individual viewing locations are fed through series connected signal splitters you run out of signal and serve early sets with too much signal

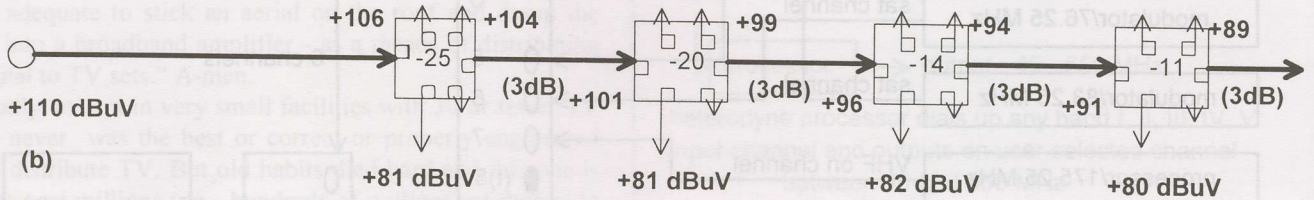

Directional taps (with 2, 4 or 8 outputs) plus isolated input AND output terminals allow you to select "tap attenuation values" to match line levels at each point

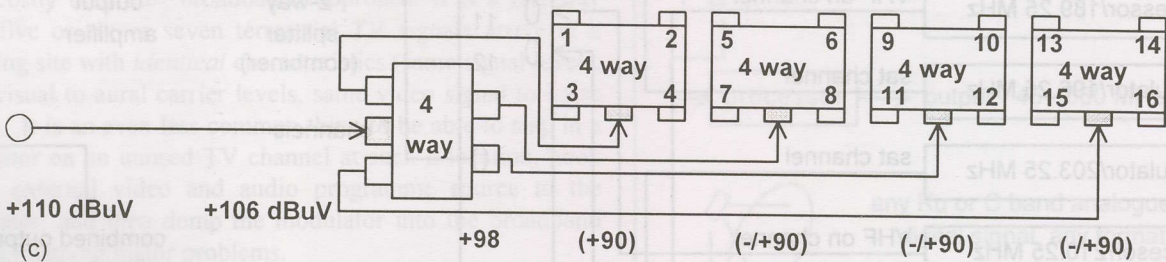

By placing four-way splitter at start of distribution portion, using it to feed four separate four-way splitters - each of which serves 4 (total of 16) outlets, system through losses improve dramatically over example (a) at top of this illustration.

network of three 4 way splitters plus a 3-way to combine 12 channels has a cumulative combining loss of 12.4 dB and isolation of not more than 27 dB.

Isolation is very important because it determines where the processor and modulator signals end up. Having a +110 dBuV system created signal on 55.25 MHz ending up only 14 dB down (-14 dB) on the output port of a 61.25 MHz signal processor is not healthy. Page 11 shows how by using a purpose-designed unit called a "headend combiner" you can isolate signals by a minimum of 35 dB. In any combining system, some signal will always "flow" to the wrong ports or connectors. The trick is to minimise this effect. Headend

combiners are not expensive, their "combining" losses similar to what you would have by using splitters (study carefully drawing at top and on left, p. 11).

Splitters are also not the correct way to distribute the signals after combining. Above, three techniques for doing this - top (a) and bottom (c) with splitters only, middle (b) using directional taps. In each case we begin with +110 dBuV of signal. In (a), placing a series of 4-way splitters on the line, after 16 outputs we have dropped +110 dBuV to +65 dBuV. Not good. In (b) we have +89 dBuV left on the line for the next set of outlets, and have carefully delivered around +80 dBuV to each TV set. In (c) we also have +90 dBuV to each

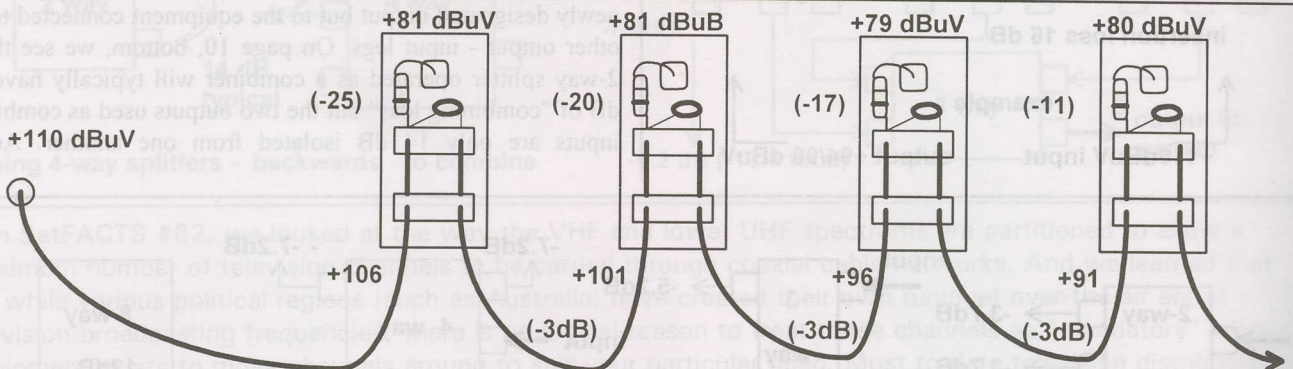

"Series connected" wall plate outlets with internal resistive attenuators and RF coupling capacitors along daisy-chain "Christmas light" wiring approach



# **ONE SOURCE**

**the 15th of the month:**

***SatFACTS Monthly***

**(around) 1st of the month:  
*COOP'S TECHNOLOGY DIGEST***

**Each and every Sunday:  
*SPACE Pacific Report on Mediasat***

**Monday, Wednesday and Friday:  
*SPACE Pacific Report on Westlink***

**Every day - all day - 12,202 "hits" during October:  
<http://www.satfacts.kwikkopy.co.nz>**

**Do YOU have something you'd  
like to say to this industry?**

**Advertising information from Bob Cooper at  
tel 64-9-406-0651, fax 64-9-406-1083,  
e-mail [Skyking@clear.net.nz](mailto:Skyking@clear.net.nz)**





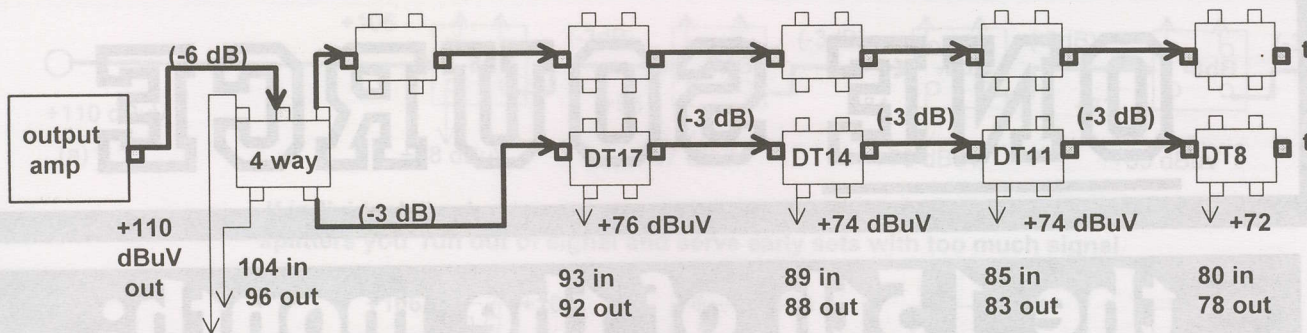

How much is enough signal? 75 dBuV is an adequate number for most TV sets. But the signal level at the DT output is not your level to the TV. When a 2-way splitter is inside the room/house, cable loss from DT to splitter + splitter losses must also be considered.

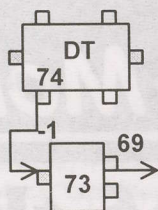

○ +110	55 versus 550	○ +110
□ P -12 dB	MHz? Passive	□ P -12 dB
≡ -28 dB	losses are the	≡ -10 dB
	same at both,	
	cable losses are	
	lower at 55	
	MHz. Left, 550	
	MHz; right, 55.	

TV set but the next splitter will be +82 and the one after that will be +74. Moreover, remember the isolation factor - with 27 dB of isolation in a typical 4-way splitter, a TV set connected to one leg of the splitter is but 27 dB "removed" or isolated from any other set fed by the same splitter.

Directional taps (also known as directional couplers) have superior isolation, and if you know or calculate the actual distribution line level at each location where a 'DT' is installed, you can then select the dB of "attenuation" for the DT. If you want 80 dB signal to the TV set, and have 90 dB of line level, the 'DT attenuation value' chosen would be 10 dB. Values available range from 4 dB to 30 dB.

At the bottom of p. 11, a rather antiquated way of series wiring a building. The first "tap point" has the distribution line 'loop-through' and the wall-plate tap has a unique set of resistor and capacitor values that attenuates the signal to and through the wall plug coaxial socket by a calculated number of dB. This is similar to the 'DT' approach except typically each wall-plate tap off has but a single output. The disadvantage of this is similar to what you experience with a set of bargain basement Christmas Tree lights - by having everything 'in series', any fault at one will kill it for all that follow.

#### How much signal?

Because there is a "spectrum" of channels involved in the typical installation, the designer must consider how different frequencies are attenuated through the coaxial network. The lower the frequency (such as 55.25 MHz), the lower the cumulative cable loss. Ideally, the lowest channel frequency in

the system and the highest channel frequency appear at each TV set "drop" point equal in level.

If we are using cable with 5 dB loss per 100 metres, and the longest cable length is 500 metres from the head end, the total cable loss will be 25 dB. But at what frequency is 5 dB loss?

You must know the cable losses at different frequencies within your spectrum - in particular at the lowest frequency used and again at the highest frequency. If 5 dB per 100m is at the highest frequency, a cable loss chart will suggest the lowest frequency loss in the same 100m will be 2 dB. So 500m of 2 dB loss is 10 dB loss; a 15 dB difference between the lowest and highest frequencies.

The design goal is to end up with equal signal levels at the far end. What this means is the headend output level must be adjusted to reflect the dB 'offset' between the two extremes - you leave the headend with 15 dB more signal at the highest frequency than at the lowest. Those channels in between lowest and highest are stair stepped accordingly.

Splitters, DTs have equal loss at all frequencies, called 'lumped loss.' Thus they contribute system loss but evenly across the full spectrum. Splitter losses are identified on the bottom of p. 11. DT 'losses' reflect the amount of signal being taken out of the line at each DT insertion point - varying from under 1 dB for 30 dB attenuation DTs to 3 dB for the 4 dB versions.

Planning a system involves making a paper plan, placing all parts where they should be, and summing the total losses (cable and passives) - a subject we will look at next time.

## small, medium and LARGE C and Ku antennas in stock!

Transmit and receive antennas from 1.2m to 13m (Intelsat Standard B). Linear and circular feeds (AsiaSat, Palapa, JcSat, Rimsat, PanAmSat, Intelsat and more) for transmit and receive-only applications. Receive and transmit electronics including inclined orbit tracking equipment with motor drives for elevation and azimuth to 50 tons. Complete system design, fabrication, installation + proof of performance.

P  
A  
C  
I  
F  
I  
C



Limited

A  
N  
T  
E  
N  
N  
A  
S

### Pacific Antennas Limited

Bryon G.G. Evans, PO Box 265, Whangaparaoa, NZ  
Tel/fax 64-9-424-0841 • Mobile 025-789-160



## MadMax Case Provokes International Reaction

Rolf Deubel was scheduled to appear (for the third time) before a Thai Judge in the Court of Intellectual Property Rights October 22. Case number '(Red) 1320/2542' was adjourned until November 3rd. On that date, Deubel and a local (Thai) man arrested with him on September 13 entered guilty pleas to charges of violating the Thailand 1994 Copyright Act. Specifically, they were pleading guilty to conspiracy to duplicate copyrighted material belonging to Mindport and licensed to UBC, the Thai pay television company. On entry of the 'Guilty Plea,' the judge sentenced the two men to 1 year in prison but then suspended the sentence for two years provided a fine of 200,000 Baht was paid.

On October 31, Stephen Jakobi of the London based Fair Trials Abroad agreed to assist the Deubel family in getting appropriate legal representation for Rolf. Fair Trials is a non-profit trust established to assist people who find themselves jailed in a strange land, unable to defend themselves and often unable to even understand the nature of the charges. On that same date, Amnesty International began a review of the case.

From the time of his arrest, Rolf Deubel's only apparent contact with the outside world was the German Embassy. Here, two men handled the case. Herr Schick - consul to Bangkok, and Herr Wiehauser - public relations officer, reluctantly took on the matter. They had no real choice - this was their job and Deubel was travelling with a German passport. Part of their job was to notify and provide information to Deubel's family. Mrs Deubel had but one advisory from the Embassy and that was October 12th - almost four weeks after MadMax "disappeared" into the inner sanctum of the Thai legal system. SatFACTS repeatedly attempted to talk with either Schick or Wiehauser - both refused to talk with us even after we came into contact with Rolf's wife in Cape Town and at her request carried messages from her to the German Embassy requesting information about Rolf's status. In desperation she would call them on November 3rd, after the scheduled adjourned 'court hearing,' and be told "We can tell you nothing but will advise when we know something." Mrs Deubel learned of the judge's ruling only from SatFACTS - the German Embassy never did call.

Fair Trials Abroad offers legal advice, legal representation and arranges on the ground investigation to assist "clients." It works only at the request of either the indicted or his/her immediate family. The request for assistance here had to

### -Letters to the Editor-

"After reading your report about 'MadMax lands in Thailand Jail,' I was quite surprised having walked through customs at Don Maung Airport, Bangkok some 19 times over the past 9 years with my modified (external pre-amp) short-wave radio. Does this mean I have avoided a possible 5 years in a Thai jail?"

"You would think the Economic Crimes Investigation Division (ECID) in Thailand would have bigger fish to fry than MM. They could start at Pantip Plaza where almost any piece of software for the PC, Mac, Sony P/S can be purchased for \$6 AUD per CD.

"But the Thai's are well known to care more about their own intellectual property rights (you can prove this by trying to locate a fake tape of a Thai recording artist). So it comes as little surprise (especially when a little tea money is involved) that MM was busted for nothing more than a modified radio and some intent to perhaps make cards to unlock the UBC encryption."

TW, Victoria, Australia

"PS - tea money is money for bribes and favours."

...

"What hypocrites! You can buy fake Rolex watches, CDs and DVDs from the entire world market, every computer programme ever offered for sale anywhere, in Bangkok on virtually any street corner or in any street market. The ECID is a joke in Thailand if you are a local. The only people they prosecute are those who fail to bribe the officers and the bribes are usually very small - a handful of CDs or videos typically does the trick."

LJH, Brisbane, Qld.

originate with Rolf's wife and daughter in Cape Town.

Amnesty International has a broader set of rules but because of their well known visibility is less able to respond as rapidly as Fair Trials. Amnesty does make available on the Web an excellent 30+ page tutorial titled Amnesty International Fair Trials Manual which establishes the basic legal rights of someone jailed without due process (<http://www.amnesty.org.ailib/themes/fairtria.htm>).

All of the evidence in this case - not withstanding the 'guilty plea' reported through the Intellectual Rights Court - suggested Deubel had been the target of a carefully orchestrated plan created by Mindport - the parent of Irdeto.

For example, SatFACTS learned that Deubel maintained all of his business records and smart card decryption data on or with a lap top PC he carried with him to Thailand. And the lap top became a primary "piece of evidence" after the arrest. Inside, probably in code but remember who now had their hands on the PC - names, addresses, products supplied, dates, remittances, e-mail exchanges. A virtual "gold mine" of information for Mindport. Were there additional records at his home or office in Cape Town? Mrs Deubel on November 2

had a surprise visit from a man she described as "Indian." He left her with his business card after asking a series of questions relating to Rolf's business activities and trip to Australia earlier this year. SatFACTS used the information on the business card to check this guy out. Nothing did. And for the record, Mrs Deubel was forced to follow the "Saga of MadMax" (her husband) on the SatFACTS Web site - at a friend's home because their only in-house PC is broken and "Rolf never found time to fix it." The strange visit significantly upset Mrs Deubel - and it was probably not a coincidence that he called on the Deubel homestead only days after Australian piracy Web sites were reporting the sudden arrival in Australia of equipment ordered just prior to Rolf's Bangkok trip. Was there somebody in Cape Town filling orders? Was Mrs Deubel filling in for her missing husband?

No to both suggestions. Rolf had no business 'partner' in Cape Town, and his wife (and family) only knew that he was in the "computer or satellite business" and "must travel a great deal." The late October arrival of equipment was quickly sorted - the postmarks revealed it had been shipped just days



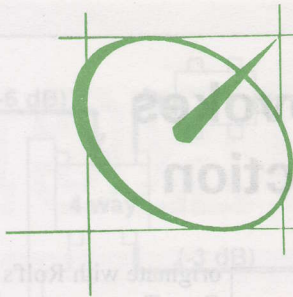

# SATECH

Satellite Communication Technology Pty. Ltd.

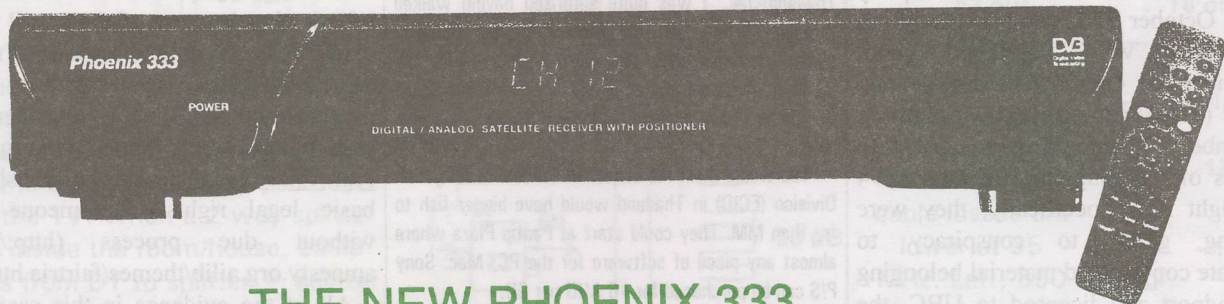

## THE NEW PHOENIX 333 with new software

Phoenix 333 - as quoted in November issue of SatFACTS " If we were forced to make a decision between owing any digital and any analogue receiver we would decide on owing the Phoenix 333"

- 3 in 1 Digital-Analogue-Positioner - High Sensitivity on Digital
- Low Threshold on Analogue - Heavy Duty Power Supply for Positioner



## THE NEW PHOENIX 111 " REVOLUTIONARY IN COST AND PERFORMANCE "

Phoenix 111 - power supply and software specially designed for Australian conditions

- Digital - High Sensitivity Loop through Tuner
- Built Digital NTSC to PAL Converter - Heavy Duty Power Supply

Sole distributor for Phoenix Worldwide

# SATECH

Satellite Communication Technology Pty. Ltd.

Head Office: 6/477 Warrigal Road Moorabbin East Victoria Australia 3189 Ph: 613 9553 3399 Fax: 613 9553 3393



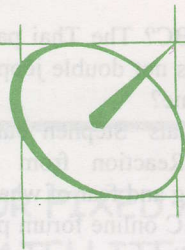

# SATECH

Satellite Communication Technology Pty. Ltd.

## SATECH Distributors for the full range of CALAMP

### CABLES

Times Fibre & Comscope

huge range of RG6 & RG11

- duel
- quad
- flooded
- messengered

also 5 core tracking system cable  
( available by reel or per meter )

RG 6  
dual  
\$99



- CALAMP C band 25k voltage switching LNBF
- CALAMP KU band 1db prime focus voltage switching LNBF
- CALAMP KU band 1 db off-set voltage switching LNBF
- CALAMP C band digi-ready phase locked loop 25k LNB
- CALAMP C band mini-mag 17k LNB
- CALAMP C band mini-mag digi extended 20k LNB
- CALAMP KU band 0.8 db LNB
- CALAMP KU band 1db high stability LNB
- CALAMP C band extended professional II low phase 20k
- CALAMP MMDS integrated antenna

also available cyclone 2.3m mesh dish

easy to install

reilable

cost effective

## CHECK OUT OUR WEB PAGE ON

[www.satech.com.au](http://www.satech.com.au) or email to us at [satellite@satech.com.au](mailto:satellite@satech.com.au)

### One Stop Shop

- receivers
- dishes
- cables
- fly leads
- wallplates
- feedhorns
- Lnbs
- tools
- tape
- poles
- deektite

**SATECH**  
Distributors  
for the  
full range of  
**PARACLIPSE**

Ring us for the latest products from Strong Technologies

- Dishes 65 cm, 90 cm and 2 - 3 m
- LNB's
- Digital Receiver

### DISHES

**SATECH your no.1 paraclipse distributor for the complete paraclipse range**

Paraclipse Dishes

- exceptional strength and wind resistance
- accurate reception

when  
quality  
counts

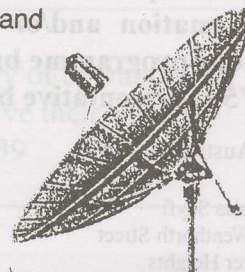

**Paraclipse**  
HIGH PERFORMANCE ANTENNAS

All products available through the following SATECH distributors:

- Satech (Victoria) Tel: (03) 9553 3399
- South Satellite (South Australia) Tel: (08) 8377 0955
- Network Satellite Services (NSW) Tel: (02) 9687 9903
- Norsat (Western Australia) Tel: (08) 9451 8300
- Mathews Electronic Service Services (New Zealand) Tel: (09) 634 5130, outside Auckland 0800-777 376



before Rolf left for Bangkok, via surface mail - a 7 to 8 week journey as it happened.

200,000 Baht? On the day of the sentence, this was US\$4,822.22. That's right - less than \$5,000 "total fine" (for both Deubel and his Thai co-defendant). SatFACTS has not been able to learn how the fine was paid, but it was. Nobody knew this at the time and the Deubel family was busy raising the funds from family members when the next bit of news came through.

"Immediately after the fine was paid, the police re-arrested Rolf Deubel." The charges which held him in Bangkok Special Prison on Ngam-wong-wan Road were brought by Mindport. Deubel's "admission of guilt" on November 3rd ended that case. His re-arrest? "New charges have now been brought by UBC - he is next scheduled before the court in a new request

for bail." UBC? The Thai pay-TV firm that uses Mindport's Irdeto. Is this not double jeopardy - being charged twice with the same crime?

Fair Trials' Stephen Jakobi: "*This is not unusual in Thailand.*" Reaction from Deubel's supporters was less understanding and fear of what might be said against Mindport on the THOIC online forum prompted the Webmaster to warn (November 7):

"*It would be appreciated if any 'Irdeto' oriented views or comments are kept off-topic from this board until I have received confirmation that Rolf has indeed rejoined his wife in South Africa. We all know Mindport scour these forums and I don't want to give them any material to work against Rolf.*"

The second charge. Mindport's original charge of violating (or conspiring to violate) the Mindport "copyright" of their data stream, under the 1994 Copyright Act, had the encryption company as the 'Plaintiff.' In Thailand, UBC is the by-contract user of the Mindport Irdeto system. When UBC puts their data stream out into the airwaves, it is a *combination* of Irdeto supplied software and their own unique-to-Thailand software. The second charge by UBC deals with the same situation as the first case - only this time it is Copyright Holder UBC as the plaintiff for that portion of the data stream which *they create* in Thailand. In effect, Rolf Deubel is back to September 15th all over again. Now, as then, the first step is to court and a (new) request for bail - the right to be released from jail in return for posting a cash bond to ensure his appearance at a future (UBC) trial. On four occasions during the Mindport case Rolf Deubel requested bail and the judge said "no" each time. A 500,000 Baht bail was set for the Thai man arrested with Rolf originally - around US\$12,000 - paid, and the man went free until the November 3rd appearance and entering of a guilty plea.

"*Has anyone considered a support fund to help MM? Maybe one of the members who is closer to him could organise the money to get to the right place. I'll kick in with \$100 if the forum is inclined.*"

This category of THOIC postings in support of Rolf Deubel began to appear on November 7th, and continue as SatFACTS goes to press.

"*I am sure to be MM's best friend and I have checked almost every day to see if Rolf is back home. I am sure he will call his wife the moment he gets out of jail! We are trying to get money together for his release. Information we have is that they ask 100,000 DM (US\$51,000 presently - ed). At this time we are short about 30% of this.*"

The writer, a European, has been previously mentioned in MadMax e-mails received by SatFACTS. Where the 100,000 DM number comes from is a mystery to us - but it may have originated through the German Embassy in Bangkok. Or it is simply someone's guesstimate of what the costs might be - either for a bail if set or a fine if assessed in the UBC case.

Other activity. Shortly after Rolf Deubel and his lap top were under Mindport control, European pirate provider Eurosat Electronics was raided. Then during the first week in November, two more pirate names were "visited" by Mindport and French firm Seca; Bakker Electronics and Multisat. Bakker had at one point provided over their Web site software that would convert the Nokia 9200 IRD to a "bullet proof" receiver using a blocker system. Bakker removed this information from their Web only weeks after it first appeared. As Mindport told SatFACTS in October, "*this is not a good time to have had any association with Madmax.*"

# WRN



English World Class radio from 14 nations, 24 hours.  
AsiaSat 2, 4000Hz, Sr 28.125, FEC 3/4 (select WRN  
from audio menu, left hand audio).

Listening tip of the month: **Car Talk**, live from  
National Public Radio USA 1600 UTC Saturdays.

## World Radio Network



# TV5

France, is available "free to air" 24 hours a day in digital on Asiasat2 (100.5E) and in analogue on PalapaC2 (113E). The quality of the reception is superb! For additional information and/or free subscription to a colour programme brochure, please contact TV5 representative below:

In Australia:

Natalia Sayfi  
32 Wentworth Street  
Dover Heights  
NSW 2030, Australia  
Mobile: 61 419 271 371  
Fax: 61 2 9371 4435  
E-Mail: FSAYFI@TPGI.COM.AU

In New Zealand:

Nelson Dimas  
56 Britannia Heights  
Nelson, NZ 7001  
Phone & fax: 64 3 546 9030  
E-Mail: TV5-France@clear.net.nz

TV5 WEBSITE

<http://www.tv5.org>

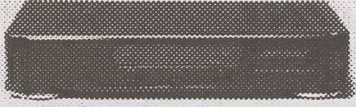

TURN YOUR FIXED ANALOG OR DIGITAL SYSTEM INTO A  
MULTI\_SATELLITE SYSTEM WITH THESE ACCESSORIES:

<p><b><u>Single Axis Positioner</u></b> Update your fixed satellite system with this positioner.</p>  <p>Cat # M1000 \$199</p>	<p><b><u>18 inch Actuator</u></b> Special price \$260. Order M1000 and M1510 together and pay only \$400 <i>SAVE \$60!</i></p> <p>Cat # M1510</p>	<p><b><u>24 inch Actuator</u></b> Special price \$280. Order M1000 and M1540 together and pay only \$420 <i>SAVE \$60!</i></p> <p>Cat # M1540</p>
<p><b><u>0/12v Coaxial Relay</u></b> Automatically switch between 2 C band dishes or a C and K band dish. Suits IRDs with 0/12V RCA outlet. \$49</p> <p>Cat # P1700</p>	<p><b><u>Manual Coax Switch</u></b> Manually switch between 2 dishes and one receiver. This switch carries DC to the LNB and is rated to 2000MHz. \$39</p> <p>Cat # S2000</p>	
<p><b><u>Dual Band Combiner</u></b> Mix the outputs of 2 LNBs at the dish and feed one cable. Saves the extra cable run and drilling through walls etc. Use a standard IF splitter like our X1550 to feed 2 receivers inside. \$39</p> <p>Cat # X1750</p>	<p><b><u>4 Way A/V Signal Switcher</u></b> Too many remotes in your house? Use this intelligent switcher to prioritize A/V sources. Input 1 has priority. If source to Input 1 is off, Input 2 assumes priority. Detects and switches the active input to 2 parallel outputs. \$99</p> <p>Cat # T1951</p>	
<p><b><u>Satmaster Lite for Windows 95/98</u></b> Use this 2 disk software to give pointing co-ords for all visible satellites from your location, calculate down-link budgets for digital and analog signals, make solar outage predictions show rain attenuation etc etc. Has huge multicountry database. \$199</p> <p>Cat # S 1101</p>	<p><b><u>Logsat Professional</u></b> CD ROM software shows visual display of multiple satellites to allow prediction of exact location of inclined satellites at any time. Updated Keplerian elements are available every day via the Internet. We use this to find inclined Gorizont, amateur and polar orbiting satellites. \$119</p> <p>Cat # S1150</p>	

**The Practical Guide to Satellite TV**

Second edition, printed this year has 122 pages of data, footprints, theory of operation and history of satellite TV. Find out how satellites work and how to receive their signals.

Written in easy to understand language, not Swahili! \$39

Cat # B1030

**AV-COMM PTY LTD** (ACN: 002 174 478)

P.O. Box 225 Balgowlah NSW 2093 Australia

TEL: 612 9949 7417 FAX: 612 9949 7095

Web: <http://www.avcomm.com.au> Email: [sales@avcomm.com.au](mailto:sales@avcomm.com.au)

You are welcome to join our E-Mail Newsletter Service.

Just send E-Mail to [addme@avcomm.com.au](mailto:addme@avcomm.com.au).

\* Prices do not include shipping and include Australian Sales Tax. ( if applicable )



a technical and marketing  
advisory

## memo

to the membership from your  
industry trade association

## SPACE Pacific

Satellite  
Programme  
Access  
CommittEe



A trade association for users, designers,  
installers, sellers of private satellite-direct  
systems in the Pacific Ocean & Asia Regions

From the creation of SPACE as a trade association, there has been a desire to create for members special money saving opportunities - a better reason to belong to the trade group, and, better opportunities to profit from the relationship. And, from time to time, there have been some reduced pricing from a small number of suppliers offered to members. Overall, it has not been an especially successful aspect of belonging to SPACE. Perhaps that is about to change.

SPACE Pacific Report is the reason. While hardly a runaway "hit" television series, the weekly programme now reaches thousands of people with an interest in satellite technology. Out of that has come renewed interest in making available to members additional incentives to belong.

Garry Cratt of Av-Comm Pty Ltd was one of the first to support the trade association as a commercial ("Distributor") member. His firm along with Satech and Sciteq presently contribute to the creation of the SPACE Pacific Report television series. Garry also appears in several of the early shows (9902, 9903, 9904) and "sponsored" Robin Colquhoun's participation in show 9905 (the Dr Overflow software report).

And he realised the importance of having an ongoing effort underway to create new, additional shows. Funding of the shows, even with the "donated" time of the participants, remains a challenge.

From conception to being on air at Mediasat and Westlink, a typical edition of SPR costs in the region of \$1,300. All of the costs are "below the line"; NTSC to PAL format tape conversions, analogue to digital reconversions, digital suite editing time, blank masters to supply edited programmes to the broadcasters, shipping charges for tapes are some of the line items of cost.

Garry's concept was to locate a product which SPACE members could utilise in their hobby or business activities, one capable of desirable performance, but priced in such a way that members would find it attractive. And built into the selling

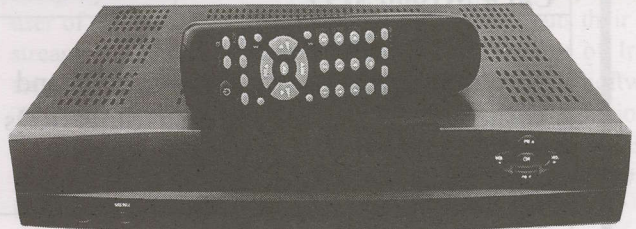

IRD allowing dealers to make money - the Xanadu.  
Biggest negative - no NTSC to PAL conversion.  
Biggest positive - special price for SPACE members.

### The Xanadu IRD

- ✓ Exceptionally straight forward, common sense on-screen menu system
- ✓ "All universe" and totally separate "Favourite channel" memories
- ✓ Preloaded with satellites and SCPC + MCPC transmission data, new transponders or new satellites quickly added
- ✓ Yes - you can enter "start" and "stop" parameters and while it takes a few hours to check, it will go through an entire satellite and load every service located thereby identifying new ones that have not even been reported yet
- ✓ LNB switching with memory (will handle up to 16 sets of antenna parameters), 0/12V, 14/18V, 22 kHz, DiSeqC
  - ✓ Handy for dealers programming IRDs for customers - RS232 "data link" to transfer full memory of a master (shop) unit to a new customer unit - ends laborious channel by channel programming
- ✓ Timer to activate receiver in user absence

## MEMBERSHIP IN SPACE

Membership in SPACE Pacific is open to any individual or firm involved in the "satellite-direct" world in the Pacific and Asia regions. There are four levels of membership covering "Individuals," the "Installer/Dealer," the "Cable/SMATV Operator," and the "Importer/Distributor/Programmer." All levels receive periodic programme and equipment access updates from SPACE, significant discounts on goods and services from many member firms, and major discounts while attending the annual SPRCS (industry trade show) each year. Members also participate in policy creation forums, have correspondence training courses available and their support makes possible the TV show SPACE Pacific Report. To find out more, contact (fax)

64-9-406-1083 or use information request card, page 34, this issue of SatFACTS. Page space within

SatFACTS is donated each month to the trade association without cost by the publisher.



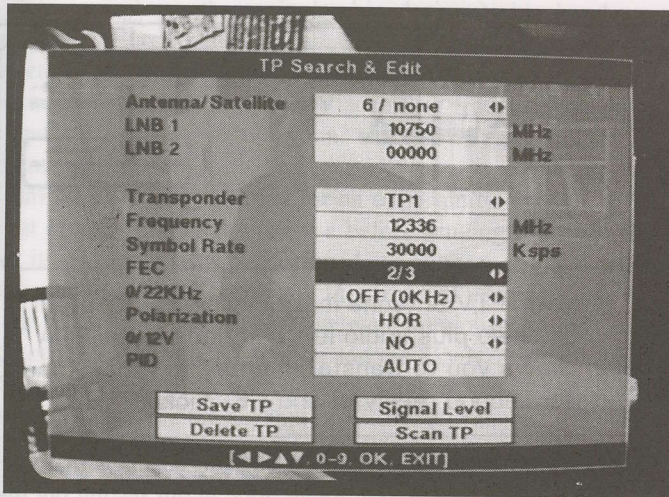

With a Chinese SCPC playing in the background, we entered our 10.750 Ku-band LO, Mediasat's 12.336 (30.000, 2/3) - above, and it instantly found 9 (TV and radio) programme channels (below).

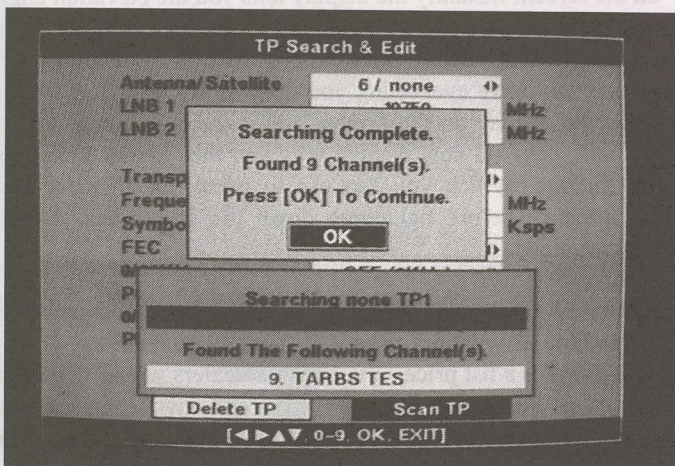

And within the Mediasat bouquet "file" TRT International in perfect format (below).



price of such a product, a "donation" to the SPACE Pacific Report TV show project. In a sense, Av-Comm is sharing profits from the product sale as a way of funding additional television programmes for the industry.

The Xanadu Digital IRD is the chosen product. As you might suspect, there is a temptation to make the product seem better than it is simply because we - like Garry - want to see the SPR series continue to grow.

## Scientific Atlanta 9708 Professional Receivers

- ✓ 99 channels C or Ku band; ✓ Tuneable audio;
- ✓ Built-in RF signal level display; ✓ UHF modulated output;
- ✓ Baseband audio and video; ✓ 950-1450 MHz L-band;
- ✓ Original cost \$2500!

**SURPLUS DEMO UNITS now \$150!!!**

**VIDEOSAT P/L, (61) (0) 2 9482 3100**

2/28 Salisbury Rd, Hornsby, NSW 2077

enquiries@videosat.com.au

The reality is no hype is required. This is a very nice IRD with a host of features and only one real negative (it does not do NTSC to PAL conversion internally). The Xanadu IRD has a number of features not commonly found in lower-price-end models.

The menu is straight forward, requires no special tricks, and operation is supported with a quality user manual. An example of this. We wanted to check out TRT reception within the Mediasat bouquet. Our B3 vertical dish has a slightly non-standard LNB on it with a 10.750 local oscillator. Each satellite can be assigned its own LNB LO switching numbers in memory and we followed the logically created menu string ending up by entering the LO and the Mediasat parameters. Instantly - as in right now - it found the bouquet and promptly listed nine services operating (radio and TV).

We then ran through the usual litany of AsiaSat 2 and 3 services working our way east to 1701. Xanadu loaded *every* service we entered, promptly and without retries or glitches. Very impressive.

There are some nice touches here suggesting the software creators have a considerable amount of first hand experience with chasing satellite signals. A few that we especially like:

**S-VHS output.** You don't hear a great deal about ultimate video quality these days and perhaps we should pay more attention to this aspect of home systems. With RGB input on a high quality receiver or monitor, the S-VHS signal produces around 50% better picture quality than standard PAL output.

**Alt-Audio.** Allows you to use remote to switch audio channels which is a shortcut to some of the TV services that carry radio channels as well.

**TV/Radio channel list.** Remote button overlays the list on the video you are watching for quick channel changing.

**EPG data.** Works (with services that transmit this information) on both TV and radio.

**Last channel recall.** Automatically turns IRD back on and to last viewed channel if AC mains power is lost (ideal for SMATV and cable use).

**Full UHF band modulator with menu set-up.**

**Teletext processing.** Does require teletext in TV set but advises you when digital signal has teletext as well.

**Organising channels.** 12 options here and you can move, skip, lock out, mark as favourite and delete in various combinations. It even does alphabetical sorts of all services in memory, from A-Z and Z-A so users don't have to remember all of the "which satellite, which channel" business - merely the name of the channel to relocate it on demand.



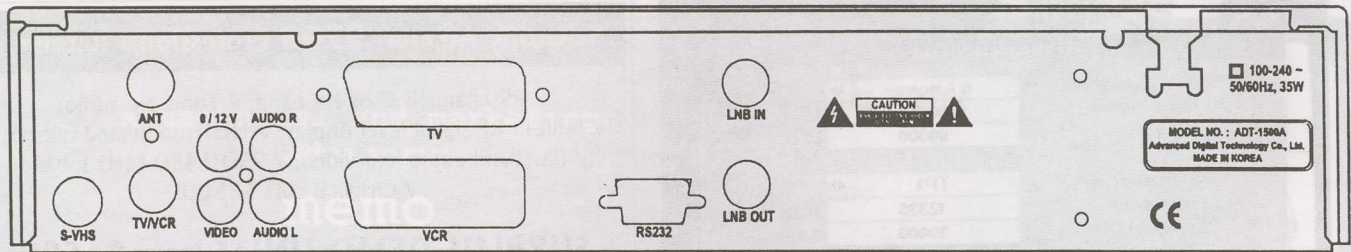

Xanadu left to right. S-VHS (high quality video) output, terrestrial TV antenna input, TV/VCR RF output (adjustable on screen through UHF range), 0/12V switching, Video plus audio left and audio right RCA sockets, twin SCART sockets for TV and VCR, RS232 which allows you to transfer memory to other Xanadu units, L-band input line, L-band loop through output (for second receiver) and CE "Ticked."

**Timer.** One of the hassles with consumer installs is trying to explain how they have to change their video taping habits. Pre-programming a VCR to record at a certain time doesn't accomplish much if the IRD is turned off. The timer allows you to set turn-on and turn-off times. Yes, it has an internal clock that includes "summer time" offset selection as well. Now to be really complete, wouldn't it be nice if you could also tell the IRD which channel to tune-to at what time! (When someone gets around to doing this software addition, might we suggest at least 8 separate time on - time off and channel selections to match typical VCR capabilities?)

**Channel search.** Ah yes, the \$64 question. Will this IRD find new services that have not previously been identified and reported by others? The answer is, "Yes it will!" but you best not be in a hurry. Say you want to scan AsiaSat 2. By using the preloaded As2 data already in the IRD, you can tell it to "Search all TP" in FTA or FTA and Scrambled modes. So far that's what most IRDs do and if a new service has come along since the memory was created, there are provisions for entering the new numbers through the menu. But if you don't know the numbers? Or don't even know the services are there?

Xanadu gives you two options:

"Added TP" uses the memory loaded original numbers as a reference, and then goes looking for new numbers not on the list.

"Detail Scan" is the "find it if it is there" mode. Xanadu asks you to define (with the remote) some parameters. For example, "Start Symbol Rate" and "End Symbol Rate." Here you are telling it the "window" of symbol rates you wish scanned. Entering "1.000" for low and "45.000" for high will catch everything in the air but adds greatly to the time required. The receiver is doing multiple scans simultaneously - first it selects a new frequency to scan (in sequence from 950 L-band upwards), then it has to do a secondary scan of the full SR range you have defined. If you were only interested in locating new SCPCs, you might enter 2.000 for low and 7.000 for high. Having done this following menu on-screen prompts, push start and go out for a nice dinner at a neighbourhood restaurant (or let it scan at night while you are sleeping). Come back in a few hours and it will present you with a list. When it finds a new transponder, it slows down and does the SR scan.

Logically, you would let it load all of the from-memory services first to establish a "base camp" and with those loaded, use the "Added TP" level of search to identify the new ones that have come along since the memory was factory loaded. Yes, with the RS232 on the rear, you can use Internet downloads to update the memory load as well.

**PID entry.** Supported for those difficult channels that won't load in a search routine (we found none in our testing but then KIBC is now off the air!).

**Dish set-up calculation.** This is cute. First you select "ANT direction help." Then you select a satellite from memory and enter your own longitude and latitude. And select "compute" on the screen. Instantly the display tells you the elevation angle and azimuth angle to the satellite. Armed with a compass, your magnetic declination information, and an "angle-finder" device, you have everything you need to set up a dish. If you leave the display on the screen, adjust the dish elevation and azimuth, next - a new display tells you the "Signal Level" of the satellite. Which you can use to tweak the dish for best performance before tightening down the adjustment settings for the antenna.

**The business deal -**

While we normally avoid pricing, there is no adequate way to explain this without prices.

1) There is a list price - the one that dealers would show to a consumer. It is A\$799. This is the price to anyone who goes to Av-Comm to buy this IRD unless they happen to be (and can validate) a currently paid-up Member of SPACE.

2) One receiver - SPACE Member price is \$649 including tax in Australia. A small adjustment to this price will apply to non-Australian SPACE Members to cover shipping charges.

3) And the best news for commercial members. If you are a SPACE "Installer/Dealer" class (or higher) member, the price is significantly lower when you purchase 5 Xanadu receivers at one time. How much lower? Talk with Garry Cratt.

**The numbers.** An "Individual Member" of SPACE pays a modest \$30 annual membership fee. In this case, it allows a A\$150 discount on the IRD. "Installer/Dealer" Members pay an equally modest \$75 per year but are allowed to buy at a very healthy discount to improve their profit for reselling.

Av-Comm will verify your SPACE Member status with us before accepting your order at the Member discount. If your dues are not current, we will e-mail (if possible) or fax you a notice and when you respond with the necessary renewal charge information (VISA, Mastercard + AMEX through Av-Comm), or authorise Av-Comm to tack the renewal onto your Xanadu invoice, the merchandise will be shipped. Yes, you can join SPACE as a new member simultaneous to ordering your Xanadu IRD.

That's it. You save money on a well designed, good working digital IRD and in the process assist in the funding of the industry's SPACE Pacific Report television programme. Contact SPACE Member Av-Comm Pty Ltd at tel +61-2-9949-7417, fax +61-2-9949-7095, e-mail at cgary@avcomm.au. We anticipate further "SPACE member incentives in the future" - stay tuned.



### On the other hand - the Nokia 9800 S

For several months a single-chip design Nokia has been available in Europe; the Mediamaster 9800 S. Initial European reports have been favourable, commending the ease of use, sensitivity, ability to add twin (Viaccess or Irdeto format) CA to switch between subscription services. Typical price is around UK375 pounds.

SatFACTS pestered Nokia for an opportunity test a 9800 S. What nobody bothered to advise before sending the IRD was that it has been software designed for Europe only. To the exclusion of any other region of the world, at this time.

In virtually any IRD we have ever previously tested - the exception being the UK Digibox and the Sky NZ clones of that IRD - you could at least create new satellite, new transponder listings by entering the appropriate menu. Not so with the 9800 S. If there is a trick to adding satellites, not only did we not discover it but repeated queries to Nokia for a clue what to do were unproductive.

There is a long list of European satellites preloaded in memory, each with the appropriate LNB and operating frequency information. If you can't add a new satellite to the memory, could we replace one or more of the European birds with Asia and Pacific satellites? The answer was no - for some reason the 9800 S only wants to be told to use a (Ku band) Universal LNB and while you can menu-modify the parameters by substituting say AsiaSat 2 for one of the preloaded European Ku band birds, when you ask it to do a search, the software jumps back to the Universal LNB settings. Not much good for C-band.

Strangely enough, 5150 LO is available in the menu, but the search routine refuses to recognise it. So is this totally useless out here? Almost. You can trick the receiver into searching for

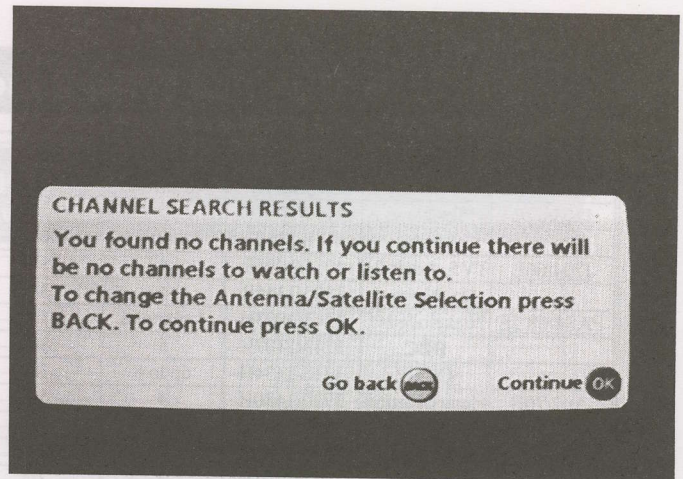

Where you end up when entering C-band parameters or 11.300 local oscillator frequency for Pacific Ku-band use.

C-band signals on a Ku band satellite but you end up with totally new (unique to the receiver) transponder frequencies and everything is "upside down" since the LO you must use of 11.300 is 219.41747% the LO of C-band (5150).

The 9800 S has all of the earmark of being another fine Nokia product and after we had pulled their chain for a week with requests for assistance, they came back asking "What new features would we like to see added for Asia-Pacific use." They subsequently suggested that when (they didn't say exactly "when") new software for the Pacific and Asia is created, our 9800 S could be reloaded with the new data and it would then perform out here. For now, unless you simply like to collect Nokia boxes, give this one a miss.

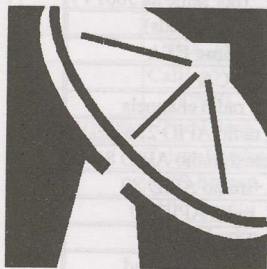

# MELBOURNE SATELLITES P/L

ACN 065 270 733

Established 1992

Direct importers and suppliers of the following world renown products.

KTI  
ORBITRON  
PATRIOT  
JONSA  
ANDREW

ECHOSTAR  
SCIENTIFIC ATLANTA  
NOKIA  
IKUSI  
DX

GARDINER  
CALIFORNIA AMPLIFIER  
MTI  
CHAPARRAL  
ADL

Full range of cables, splitters and connectors.

Phone, fax or write for our 1999 Product SATalogue.

Sales/Warehouse - 84 Bayfield Road, Bayswater Victoria  
Construction Services - 13 Elsum Avenue, Bayswater Victoria  
Postal Address - PO Box 901, Bayswater 3153 Victoria Australia

Phone: (03) 9738 0888

Fax: (03) 9729 8276

User Friendly Site!

[www.melbournesatellites.com.au](http://www.melbournesatellites.com.au)

e-mail: [sales@melbournesatellites.com.au](mailto:sales@melbournesatellites.com.au)



# SatFACTS Pacific/Asian MPEG-2 Digital Watch: 15 November 1999

Bird	Service	RF/IF &Polarity	# Program Channels	FEC	Msym	
I703/57E	Sky News	4143/1007R	1	3/4	5(.632)	
	CNBC	4018/1132L	1	3/4	6(.000)	
I704/66E	TV5, Adult 21	4055/1095R	4	3/4	27(.500)	
	Sky News +	3805/1345R	4	3/4	22(.520)	
PAS4/68.5E	Nickelodeon+	4147/1003H	1 reported	1/2	24(.000)	
	BBC	3743/1407H	5	3/4	21(.800)	
	CCTV	3716/1434H	up to 6	3/4	19(.850)	
Ap2/76E	Hmark/Kermit	3720/1430H	4	5/6	29(.270)	
	Channel "T"	3823/1327V	1	3/4	3(.570)	
	CCTV9	3833/1317H	1	3/4	12(.836)	
	TVB8 +	3849/1301H	4	3/4	13(.238)	
	Disney	3880/1270H	3	5/6	28(.125)	
	AXN	3920/1230H	up to 8	7/8	28(.340)	
	Them3/78.5E	ITC+	3520/1630H	up to 6+	2/3	26(.661)
	ITC	3569/1581H	1	2/3	13(.333)	
	MRTV	3666/1484H	1	2/3	4(.442)	
	UTV	3920/1230H	6	3/4	26(.662)	
	UTV/MCOT	3880/1270H	8	3/4	27(.500)	
	Mahar/DD1	3600/1550H	up to 8	3/4	26(.661)	
	PTV bouquet	3420/1730V	2	3/4	6(.666)	
	TV Maldives	3412/1738V	1	1/2	6(.312)	
	Thai Global+	3425/1725V	up to 7?	2/3	27(.500)	
	ST1/88E	NTSC bouq.	3441/1709H	2	3/4	5(.800)
		Pacific DTH	3468/1682V	up to 30		22(.000)
MeSt 1/91.5E	Malaysia TV3	4147/1004H	1	3/4	7(.030)	
As2/100.5E	Euro Bouquet	4000/1150H	5TV, 19r	3/4	28(.125)	
	Reuters	3909/1241H	1	3/4	5(.632)	
	Hubei/HBTV	3854/1296H	1	3/4	4(.418)	
	Hunan/SRTC	3847/1303H	1	3/4	4(.418)	
	Guan/GDTV	3840/1310H	1	3/4	4(.418)	
	Inn. Mongolia	3828/1322H	2	3/4	8(.397)	
	Saudi Arabia	3811/1339H	1	3/4	3(.905)	
	APTAN A-O	3799/1351H	1	3/4	5(.631)	
	WTN Jer/Lon	3790/1360H	1	3/4	5(.631)	
	Reuters/Sing.	3775/1375H	1	3/4	5(.631)	
	WorldNet/US	3764/1386H	1 + 20 radio	3/4	6(.100)	
	Liaoning/Svc2	3734/1416H	1	3/4	4(.418)	
	Jiangxi/JXTV	3727/1423H	1	3/4	4(.418)	
	Fujian/SETV	3720/1430H	1	3/4	4(.418)	
	Hubei TV	3713/1437H	1	3/4	4(.418)	
	Henan/Main	3706/1444H	1	3/4	4(.418)	
	As2/100.5E	TVSN	4033/1117V	1	3/4	4(.298)
Sky Racing		4020/1130V	up to 3TV	1/2?	18(.000)?	
EMTV		4006/1144V	1TV, 2 radio	3/4	5(.632)	
Jilin Sat TV		3875/1275V	1	3/4	4(.418)	
HeiLongJiang		3834/1316V	1	3/4	4(.418)	
JSTV		3827/1323V	1	3/4	4(.418)	
Anhui TV		3820/1330V	1	3/4	4(.418)	
Shaanxi/QQQ		3813/1337V	1	3/4	4(.418)	
Guang/GXTV		3806/1344V	1	3/4	4(.418)	
Fashion TV		3796/1354V	1	3/4	2(.533)	
Feeds		3785/1365V	1	3/4	5(.632)	
Myawady TV		3766/1384V	1	7/8	5(.080)	
Saudi TV1		3661/1489V	1	3/4	7(.128)	
As3S/105.5E		Arirang TV	3755/1395V	1	7/8	4(.418)
		Star TV	3780/1370V	17(+TV)	3/4	28(.100)
	Star TV	3860/1290V	14(+TV)	3/4	27(.500)	
	Star TV	3880/1270H	12(+TV)	7/8	26(.850)	
	CNNI	3960/1190H	4(+TV)	3/4	26(.000)	
Cak1/107.5E	Star TV	4000/1150H	7(+TV)	7/8	26(.850)	
	Indovision (S-band)	2.536, 2.566, 2.596, 2.626	33(+TV)	5/6	20(.000)	
Sinosat/110E	(occ) feeds	4134/1016V	1	3/4	5(.632)	
C2M/113E	Indosiar	4074/1076V	1	3/4	6(.500)	
	Space TV	4000/1150H	12TV, radio	3/4	26(.667)	
	C Net Taiwan	3760/1390H	11TV, radio	5/6	21(.091)	
JcSAT3/128E	RCTI	3475/1675H	1	3/4	8(.000)	
	Miracle Net	3990/1160V	3 up to 6	5/6	12(.997)	
	Asian bouquet	4100/1050H	up to 8	7/8	30(.000)	

## Receivers and Errata

NDS encrypted, often FTA
Feeds - typically FTA (SCPC)
FTA (Adult 21 believed off air)
Sky News 24 hr, sport, feeds; some FTA
Status unknown - was testing FTA
FTA; 2 audio channels
FTA
PowVu, typ. CA
Tests, FTA
FTA - tests, maybe MCPC shortly
PowVu, CA
PowVu, CA - operating?
Tests, promos, some FTA
many short term (Europeans) here
FTA
FTA; difficult to load
Irdeto (MOSC cards were available!)
Irdeto (MOSC cards were available!)
FTA (has included Indian, Egypt)
FTA, new service, testing
FTA (reaches SE Australia)
FTA
Open TV, Cosa TV
+3550, 3632 - some FTA
tests, possibly permanent, FTA
FTA (TV5 teletext)
FTA, occasional feeds
FTA SCPC, teletext
FTA SCPC, teletext
FTA SCPC, radio APID 81
FTA: #1 Chinese, #2 Mangolian
FTA SCPC, "Ch 1" (not same as 3661V)
FTA SCPC (news feeds)
Mostly CA; some FTA
FTA & CA
FTA; multiple radio channels
FTA SCPC, radio APID 256
FTA SCPC, teletext, radio APID 81
FTA SCPC, + radio APID 80
FTA SCPC, radio APID 80
FTA SDCPC, + radio
FTA SCPC - difficult to load
(Irdeto) CA; 1 & 3 occ. FTA
PowVu CA; poor signal level
FTA SCPC, + radio
FTA SCPC
FTA SCPC, + radio
FTA SCPC
FTA SCPC, radio APID 81
FTA SCPC, radio APID APID 257
FTA SCPC, now easy to load
FTA & CA, feeds
FTA SCPC - difficult to load
FTA SCPC; also see 3811H-not same
FTA SCPC; very strong signal
NDS CA (Pace DVS211)
NDS CA (Pace DVS211)
NDS CA (Pace DVS211)
PowVu CA; some FTA feed channels
NDS CA (Pace DVS211)
NDS CA using RCA/Thomson, Pace IRDs; improved reliability since June
FTA SCPC, difficult to load
May only be test - not reliable
CA uses "floating sequence" system
CA but subscriptions available
FTA SCPC; may not be permanent
PowerVu; TBN #3 FTA, some CA
CA and FTA, Japan, Taiwan, China



Bird	Service	RF/IF & Polarity	# Program Channels	FEC	Msym
LMI AP1/130	THT+NTV	3675/1475L	2 + 1 radio	3/4	12(.000)
Ap1A/134e	Gansu TV	3769/1381V	1	1/2	6(.930)
Ap1/138e	Reuters	3742/1408V	1	3/4	5(.632)
	Viacom	3860/1290V	up to 6	3/4	30(.000)
	SDTV	3980/1170V	1	3/4	4(.686)
Optus B3/156	Mediasat	12.336V	6TV, 3+ radio	2/3	30(.000)
	Aurora	12.407V		2/3	30(.000)
	Aurora	12.532V		2/3	30(.000)
	Aurora	12.595V		3/4	30(.000)
	Aurora	12.720V		3/4	30(.000)
	Austar/Foxtel	12.438H		3/4	29(.473)
	Austar/Foxtel	12.564H		3/4	29(.473)
	Austar/Foxtel	12.626H		3/4	29(.473)
	Austar/Foxtel	12.688H		3/4	29(.473)
Optus B1/160	ABC NTfeed	12.256V	1TV, 3 radio	3/4	5(.026)
	Central 7	12.354V	1TV	3/4	3(.688)
	Imparja TV	12.367H	1TV, 3 radio	3/4	5(.424)
	Sky NZ	12.391/418V		3/4	22(.500)
	Sky NZ	12.518/546V		3/4	22(.500)
	Sky NZ	12.643/671V		3/4	22(.500)
	Imparja feed	12.367H	1	3/4	5(.424)
PAS8/166E	Pacific Time	12.286V?	10TV	3/4	26(.470)
	ABCInterch.	12.312H	1	3/4	6(.978)
	ABCInterch.	12.321H	1	3/4	6(.978)
	Pacific Time	12.326V?	8TV	3/4	27(.500)
	ABCInterch.	12.330H	1	3/4	6(.978)
	Pacific Time	12.366V?	9TV	3/4	26(.470)
	TARBS	12.526H	12+ TV	3/4	28(.067)
	NHK Joho	4065/1085H	5TV, 1 radio	3/4	26(.470)
	CalBqt/PAS8	3940/1210H	up to 5TV	7/8	27(.690)
	CNNI	3780/1370H	3, up to 5 TV	3/4	25(.000)
PAS2/169E	GWN Perth	12.265V	4TV, 7 radio	1/2	16(.200)
	TelstraBendig	12.300V	2	1/2	21(.997)
	TCS-Singap.	4183/967V	2	1/2	6(.620)
	HK PowVu	4148/1002V	up to 8	2/3	24(.430)
	NBCHonKn	4093/1057V	5, up to 7	3/4	29(.473)
	Feeds	3942/1208V	1 or 2	2/3	7(.497)
	ESPN USA	3860/1290V	7TV, 2 data	7/8	26(.470)
	Middle East	3778/1372V	4	3/4	13(.331)
	Service 1	3761/1389V	1	3/4	6(.620)
	BBC + TFC	3743/1407V	3 to 5	3/4	21(.800)
	CCTVPowV	3716/1434V	5 typical	3/4	19(.850)
	NTV Japan	4174/976H	1	3/4	5(.632)
	Feeds	4138/1012H	1	3/4	6(.620)
	7thDyAdven	4034/1116H	1TV, 14 audio?	3/4	6(.620)
	CNNI HK	3996/1154H	1	3/4	9(.998)
	Feeds	3867/1183H	1	2/3	6(.618)
	7thDyAdven	3957/1193H	1TV, 14 audio	3/4	7(.000)
	Feeds	3939/1211H	2 (typ NTSC)	2/3	6(.620)/7(.498)
	Cal PowVu	3901/1249H	up to 8	3/4	30(.800)
	Disney	3804/1346H	3	5/6	21(.093)
	Discovery Sing	3776/1374H	8 typ	3/4	21(.093)
	Satcom 1-6	3743/1407H	up to 5	7/8	19(.465)
I702/177E	AFRTS	4177/973LHC	8TV, 12+ rad	3/4	26(.694)
	ThaiBouquet	12.650H	up to 3 TV	1/2	17(.800)
I701/180E	RFO/Canal+	11.610V	up to 13TV	3/4	30(.000)
	TVNZ	4195/955RHC	1	3/4	5(.632)
	TVNZ/BBC	4186/964RHC	1	3/4	5(.632)
	TVNZ	4178/972RHC	1	3/4	5(.632)
	TVNZ/APTN	4170/980RHC	1	3/4	5(.632)
	AFRTS Pac.	4175/975LHC	3 radio (only)	2/3	3(.679)
	RFO-Canal+	4095/1055L	7TV, 5+ radio	3/4	27(.500)

Receivers and Errata
inclined orbit +/-2.3 degrees
FTA SCPC (NT, Aust only)
FTA SCPC (NT, Aust only)
FTA, CA (NT, Aust only)
FTA SCPC (NT, Aust only)
PowVu but <b>mostly FTA</b> ; TRT, Thai5
CA, \$65 smart card required (p. 25)
CA, \$65 smart card required (p. 25)
CA, \$65 smart card required (p. 25)
CA, \$65 smart card required (p. 25)
CA, subscription available Australia
CA, subscription available Australia
CA, subscription available Australia
CA, subscription available Australia
FTA, Sydney -30 minutes time zone
FTA, purpose here unknown
FTA, purpose here unknown
NDS CA, subscription available NZ
NDS CA, subscription available NZ
NDS CA, subscription available NZ
FTA, difficult to load, not full time
Viaccess CA, some FTA at times
PowVu, FTA, news feeds
PowVu, FTA, news feeds
Viaccess CA, some FTA at times
PowVu, FTA, ABC Melbourne feeds
Viaccess CA, some FTA at times
'MDS' CA, IRDs useless other svcs
PowVu CA & FTA; subscription avail
PowVu CA & FTA
PowVu, FTA at this time
PowVu CA-WA only, D9234 required
PowVu CA, private, not available
PowVu FTA
PowVu CA, <b>some FTA</b>
Philips MPEG-2, FTA
(PowVu) FTA, occ. feeds
PowVu CA, Ch 12 bootloader updates
FTA - low level, difficult to load
(PowVu) FTA, occ. feeds
(PowVu) CA & FTA - <b>BBC #3 FTA</b>
(PowVu) FTA, # pgm chs varies
FTA SCPC feeds (occasional use)
FTA occasional feeds
0300-0400+; also see 3957H
Reverse link HK to Atlanta, feeds, FTA
FTA occ. (sport) feeds
1900-2030UTC; not daily, PowVu FTA
FTA-typ. NTSC-occ. sport, shuttle
(PowVu) CA & FTA
PowVu CA
PowVu CA
currently FTA, lowlevel, Mid East feeds
PowVu CA
Thai5 service, tests, FTA-inactive?
Testing-new pay-TV + FTA service
DMV/NTL occ. feeds, typ CA
DMV/NTL occ. feeds, typ CA
DMV/NTL occ. feeds, typ. CA
DMV/NTL occ. feeds, typ. CA
PowVu CA radio, very strong level
#1, 2 CA - rest FTA-France to Polyn.



## SatFACTS Digital Watch: Supplemental Reference Data / November 1999

Bird	Service	RF/IF & Polarity	# Program Channels	FEC	Msym	
(1701/180E)	<b>TVNZ feeds</b>	4044/1106R	1	3/4	5(.632)	<b>Receivers and Errata</b> SCPC, mixed CA and FTA feeds PowVu CA; Auckland net feeds FTA SCPC; East Hemi Beam-Tahiti SCPC, mixed CA & FTA, feeds SCPC, mixed CA & FTA, feeds PowVu CA & FTA; #3 TBN
	NZ Prime TV	4024/1126L	1	2/3	6(.876)	
	<b>RFO Polycast</b>	3858/1292L	1	3/4	4(.566)	
	TVNZ (TL)	3854/1293R	1	3/4	5(.632)	
	TVNZ	3846/1304R	1	3/4	5(.632)	
	10 Australia	3765/1385R	6	7/8	29(.900)	

**BOUQUETS - FTA vs. CA:** Listings here show SCPC (single channel per carrier) and MCPC (multiple channels per carrier) digital transmissions which "more or less" conform to the MPEG-2 DVB "standard." Unfortunately, "conforming to the standard" is interpreted differently by the various transmission equipment suppliers - of which, Scientific Atlanta is the most notorious with its PowerVu proprietary (that means "unique to SA") method of creating MPEG-2. If you want to see REAL MPEG-2 DVB-Compliant (as in world standard) signals - try AsiaSat 2, European Bouquet (4000/1150Hz). SA "modifies" their PowerVu format in an attempt to force each programmer using its uplink equipment to also use its proprietary (PowerVu) receivers. PanAmSat, closely linked to Scientific Atlanta, virtually insists that any digital service user of their satellites use PowerVu format transmission equipment. The good news is that some clever non-PowerVu receiver designers and receiver software writers have created "quasi-PowerVu" decoding routines which in many cases outperform the PowerVu originals. If your use requires access to one or more PowerVu CA (conditional access) service, you have no choice but to purchase a PowerVu receiver. If you are only interested in FTA (free to air) PowerVu services, there are many lower cost options (see below).

All services listed in bold face (i.e. **SPN Nauru**) are FTA. When MCPC services are FTA, they are also listed bold face (i.e. **Euro Bouquet**). When there are mixed CA and FTA programme channels in a MCPC bouquet, see right hand column for a bold face indication of this (i.e. **some FTA**). The primary (mostly or total) FTA MCPC bouquets are as follows: PAS4/68.5E: CCTV (3716H); Thaicom 3/78.5E: Mahar (3600H), Thai Global (3425V); As2/100.5E: European Bouquet (4000H); Optus B3 /156E: Mediasat (12.336V); PAS8/166E: NHK Joho (4065H), California Bouquet (3940H), CNNI (3780H); PAS2/169E: NBC Hong Kong (4093V), Middle East (3778V), BBC + (3743V), CCTV (3716V), California PowVu (3901H), Satcom 1-6 (3743H); Intelsat 701/180E: RFO (4095LHC), 10 Australia (3765RHC). There are far more SCPC FTA digital services than MCPC FTA digital services.

### **MPEG-2 DVB Receivers:** (Data here believed accurate; we assume no responsibility for correctness!)

- ADI MediaMate.** FTA, NTSC+PAL outputs. (Pacific Digital Sys. Pty Ltd, tel 61-2-8765-0270)
- AV-COMM R3100.** FTA, excellent sensitivity (review SF May 1998); new version Sept. '99. Av-COMM Pty Ltd, 61-2-9949-7417.
- Benjamin DB6600-CA.** FTA, Foxtel/Austar w/CAM+card. Try Steffen Holz +687-438-156.
- Grundig DTR1100.** Mfg by Panasat (SA), very similar to Panasat 630; out of production. Irdeto capable. See Av-COMM above.
- Humax F1-CI.** Primarily sold for TRT(Australia), does (limited) PowerVu, other claims unsubstantiated.
- Hyundai-TV/COM.** HSS100B/G (Pacific), HSS-100C (China) FTA. Different software versions; 2.26/2.27 good performers, 3.11 and those with Nokia tuners also good; later 5.0 not good. SATECH (V2.26) 61-3-9553-3399; Skandia (V3.11) 61-3-9819-2466.
- Hyundai HSS700.** FTA, PowerVu, SCPC/MCPC. Review SF March 1999. Kristal Electronics, 61-7-4788-8906.
- Hyundai HSS800CI.** FTA, Irdeto (with CAM) + other CA systems, PowerVu, NTSC. Kristal Electronics (see above; review p. 6).
- Mediasat.** Specific for RFO Canal+ pay-TV/FTA service. CA, no probable other use. Antenne-Cal at +687-438-156.
- MediaStar D7.** FTA, preloaded w/ known services, exc. software (review SF July 1998). MediaStar Comm. Int. 61-2-9618-5777
- MultiChoice (UEC) 660.** Essentially same as Australian 660, not grey market contrary to reports. Sciteq tel 61-8-9306-3738
- Nokia "d-box" (V1.7X).** European, FTA, may only be German language, capable of Dr. Overflow software. Tricky to use.
- Nokia 9200.** When equipped with proper CAM, does Aurora, pay-TV services provided software has been "modified" with Dr Overflow or similar program (www.BAKKERELECTRONICS.COM- Note: This site shut-down by Mindport early November - may not be functioning!). Has factory 12 mo. warranty. Peter Older, tel 61-3-5133-7911, mobile 61-0418-386287
- Nokia 9500/9600.** Numerous versions for different world parts; not distributed in Pacific but assistance from Av-Comm Pty Ltd.
- Nokia 9800.** Latest single chip version, with CI and Irdeto capable. No software for Pacific, Asia; not recommended.
- Pace DVS211.** NDS CA (no FTA) for Star Asia, previously used for Indovision. (Solution 42, 61-2-9820-5962)
- Pace DGT400.** Originally Galaxy (Now Foxtel+Austar). Irdeto, some FTA with difficulty (Foxtel Australia 1300-360818)
- Pace DVR500.** Original DGT400 modified for NBC (PAS-2) affiliate use, with CAM equivalent to DGT400 but more reliable.
- Pace "Worldbox"** (DSR-620 in NZ). Non-DVB compliant NDS CA including Sky NZ, no FTA; similar "Zenith" version.
- Pacific Satellite DSR2000.** Advises no longer current model (see. p. 2, here); Clone of Mediastar D7 (see above)
- Panasat 520/630/635.** MCPC FTA, Irdeto capable, forerunner UEC 642, 660. Out of production, spares fax ++27-31-593-370.
- Panasonic TU-DS10.** FTA + Irdeto CA; one of 2 IRDs approved by Optus for Aurora, but no longer available in Australia.
- Phoenix 111, 222.** PowVu capable, NTSC, good graphics, ease of use. (SF 111 review May 1999). SATECH - see below.
- Phoenix 333.** FTA SCPC, MCPC, analogue + dish mover. Detailed SF review Nov. 1998. SATECH 61-3-9553-3399.
- PowerCom.** FTA, PowVu, NTSC, excellent sensitivity. NetSat 61-2-9687-9903.
- PowerVu (D9223, 9225, 9234).** Non-DVB compliant MPEG-2 unless loaded with software through ESPN Boot Loader (see below). Primarily sold for proprietary CA (NHK, GWN+ PAS-2 Ku, CMT etc). Scientific Atlanta 61-2-9452-3388.
- Praxis/DigiMaster 9600 MKII/9800AD.** FTA, PowVu+analogue, withdrawn from sale in Pacific (was Skyvision-below)
- Praxis 9800 ADP.** FTA SCPC/MCPC, PowVu, analogue, positioner. SF review Dec '98; withdrawn from Pacific sale (below).
- Prosat 2102S.** FTA SCPC/MCPC, NTSC/PAL, SCART + RCA. Sciteq 61-8-9306-3738.
- Samsung DSR2400.** FTA, reported not sensitive, recently released Asia - no Pacific sources.
- SatCruiser DSR-101.** FTA SCPC/MCPC, PowVu, NTSC/PAL. (Skyvision Australia 61-2-6292-5850, Telsat 64-6-356-3749)
- SatCruiser DSR-201P.** FTA SCPC/MCPC, PowVu, NTSC/PAL, analogue, positioner - review this issue (Skyvision - see above).
- Skandia SK888** (aka DigiSkan-SMS). FTA MCPC, Irdeto CAM+software upgrade. Out of production; Skandia 61-3-9819-2466
- UEC642.** Designed for Aurora (Irdeto), approved by Optus; limited other uses. Nationwide 61-7-3252-2947.
- UEC660.** Upgraded UEC642, used by Sky Racing Aust., Foxtel-limited FTA. (Nationwide - above); power supply problems.
- Xanadu.** DVB compliant special receiver for members of SPACE Psific (Av-comm Pty Ltd, tel +61-2-9949-7417)
- Yuri HSS-100C.** FTA, clone of Hyundai, V2.27 software custom to Australia (Nationwide-above).

#### Accessories:

- Aurora smart cards.** Sold independent of IRD purchase by Sciteq (\$65), other sources require IRD purchase 61-8-9306-3738.
- PowerVu Software Upgrade:** PAS-2, 3860/1190V, 26.470, 7/8; Tune pgm ch 12 and follow instructions (do not leave early!)



## SatFACTS Pacific/Asian FTA ANALOGUE Watch: 15 November, 1999

Copyright 1999: SatFACTS, PO Box 330, Mangonui, Far North, New Zealand (<http://www.satfacts.kwikcopy.co.nz>)

BIRD/Location	RF/IF & Polarity	Service	Errata
1703/57E	3808/1342R	Udaya TV	
	4052/1098R	WorldNet	VOA subers.
	4178/972L	MTA Inter.	
1604/602/60E	4166/984	various feeds	
1704/66E	3765/1385R	tests	
	4015/1135L	Mongolia	(SECAM)
PAS4/68.5E	3743/1407V	RTPi	(+ radio subcr)
	3864/1286V	BBC World	
	3907/1243H	Sony TV	Hindi
	4034/1116V	Doordan	(various)
	4087/1063H	CNNI	
	4110/1040H	TNT/Cartoon	
	4113/1037V	Series Ch.	
	4182/968H	MTV	
PAS7/68.5E	3470/1680V	test signal	
AP2R/76E	3745/1405V	Vasta Music	(P5 in NSW)
	3760/1390H	TEN tests	
Thaicom3/78E	3871/1279H	TVT	
	3760/1390V	Army TV	
	3690/1460V	MRTV	
	3685/1465H	Myanmar TV	+ radio 7.6
	3616/1534V	ETN	
	3594/1556V	AGK	test card
	3576/1574V	ATN Bangalr	Bengali
	3554/1596V	RAJ Plus	
	3536/1614V	Punjabi TV	(occ service)
	3514/1636V	Falak TV	
	3489/1661H	Vasta Music	occ tests
	3465/1685V	RAJ-TV	
Express 6/80E	3672/1478L	TK Rossija	(north beam)
InSat 2E/83E	3481/1669V	Sun TV	
	3575/1575V	Vijay/Asianet	aud. 5.5/6.6
	3810/1340V	DD1-Tamil	"
	3850/1300V	DD1-National	"
	3930/1220V	DD2 Metro	"
	3970/1180V	Teluga 1	"
	3998/1152V	sport feeds	"
	4035/1115V	Sun TV	"
	4060/1090V	Surya/Sun TV	"
	4093/1057V	DD7	"
ChnStr1/87.5E	3880/1270H	occ feeds	P4 NSW, Ntsc
ST1/88E	3550/1600V	test card	
	3582/1568V	Nila TV	(vintage TV)
CIS S6/90E	3675/1475R	RTR1	P3 NSW
	3875/1275R	Orbita 1	
	3916/1234R	RTR II	
	3935/1215R	Orbita II	
MeSat-1/91.5E	3710/1440H	VTV1,2, 4	
	3880/1270H	RTM-1	
InSat 2B/93.5E	4165/985H	India Metro	NSW on 3.7m
	4125/1025V	India National	NSW on 3.7m
	4080/1070V	DD7 (Tamil)	
	4070/1080H	DD9	
	3970/1180V	DD9 (Kan.)	
	3882/1268V	DD1	
	3840/1310V	DD?	
	3762/1388V	DD4	
AsSat2/100.5E	3642/1508H	ERTU Egypt	
	3660/1490V	feeds, tests	
	3680/1470H	feeds	
	3860/1290V	feeds	

LMIAp2/142.5			
BIRD/Location	RF/IF & Polarity	Service	Errata
(As2/100.5E)	3885/1265H	WorldNet	VOA subers
	3960/1190H	CCTV4	
	3980/1170V	RTPi	+5 radio svcs
CIS S21/103E	3675/1475R	RTR	
	3875/1275R	Vrk Apt	
AsSat3S/105.5	3660/1490V	Z-Marathi	audio 6.6
	3680/1470H	CETV	
(temp FTA)	3800/1350H	Star Sport	NTSC
(temp FTA)	3840/1310H	Channel [V]	NTSC
	3900/1250H	AlphaTV Punja	
(temp FTA)	3920/1230H	Phoenix Ch	NTSC
	3940/1210V	Zee India	
	3980/1170V	Zee TV	
	4140/1010V	Angla Bangla	
	4060/1090V	Zee Cinema	(Starcrypt)
	4100/1050V	PTV2/World	
	4120/1030H	CCTV	NTSC
T'kom1/108E	4000/1150H	tests	
PalapC2/113E	4160/990H	(France) TV5	
	4140/1010V	Brunei + feeds	
	4120/1030H	MTV Asia	
	4080/1070H	Herbalife	+ tests
	4040/1110H	CNBC	
	3970/1180V	CNNI	
	3880/1270H	Aust ATN7	
	3840/1310H	TVRI	tests
	3742/1408V	RCTI	English suber
AsSat1/122E	3677/1473V	Test card	& 3933/1217H
ChinS 6/125E	4085/1065V	feeds	seldom seen
JcSat3/128E	3768/1382V	feeds	occ., P5 NZ
	4085/1065V	test card	NTSC. 6.8 aud.
Ap1A/134E	4160/1050V	CETV	
	3980/1170V	CETV1	
	3900/1250V	CETV2	
Ap1A/138E	4160/990H	CCTV7	
87/140E	3675/1475R	ORT Moscow	+/-4d. inclined
	3875/1275R	feeds, tests	
LMAp2/142.5	3675/1475L	occ. tests	+/- 3 deg inc.
Ag2/146E	3787/1363H	GMA	P1/2 s. eqtr
Me2/148E	4080/1070H	test card	occ. use
PAS8/166.5E	3880/1270V	test card	not full time
	3865/1285H	Napa test card	not fulltime
PAS2/169E	3940/1240V	Napa test card	
1802/174E	4166/984R	Feeds	
	4177/973R	Feeds	
I702/177E	4166/984R	Feeds	inc. KBS Korea
	4187/963R	Occ. feeds	
I701/180E	3810/1340R	Occ. feeds	
	3841/1309L	RFO	East Beam
	3845/1305R	Occ. feeds	inc. from USA
	3930/1220R	USA net feeds	FTA & encrypt
	3975/1175R	Occ. feeds	
PAS4/68.5E	3785/1365V	Discovery India	BMAC
	3860/1290H	ESPN India	BMAC
Ap2/76E	3960/1190H	HBO Asia	GI Digicipher2
C2/113E	3930/1220H	Filip. Peo. Net	GI 1.5 MPEG
Ap1/138E	4100/1050V	ESPN	BMAC
PAS2/169E	3836/1341H	ABS/CBN	GI 1.5 MPEG
	3989/1161V	Fox/Prime	SA1.5MPEG



## BEGINNER'S CORNER

Motor drives and actuators. The lure of "all of those channels" from "so many satellites" usually causes a new enthusiast to seriously consider installing a motor drive on his or her dish system. Let's talk about that. Not all dishes are designed for motor drive, some are intended to be adjusted and left pointing only at a single satellite. To be outfitted with a motor drive, the dish mechanics must be right - identified as a "polar mount dish." Actually, it is not the dish that is special - it is the mount. Polar mounts cost more than "fixed" dish mounts (also known as Az/El or azimuth [over] elevation mounts). A motor drive is typically a DC voltage (36 volt or less) ram screw - a motorised winding system that screws a large threaded bolt into and then out of a container (the "arm"). As the (jack) screw becomes physically longer while the motor turns a gear box, the position of the dish changes. In the Pacific, most arms mount on the west side of the pole that supports the dish - between the pole and an attachment point on the dish proper. The dish itself is on a swivel which allows the dish to move in a general east-west direction (and back). The jack screw provides the force to push the dish west, pull it east. The "Polar Mount" mechanism when properly installed allows the dish to trace in the sky the Clarke Orbit Belt - that imaginary arc in the sky where all satellites are located. A dish jack screw + motor is essentially useless unless there is (1) a way to direct the dish movement, and, (2) a way to know where the dish is pointing at all times. Even if you can "see" the dish from inside the house, it is not possible to determine precisely where it is directed without some instrumentation. Built into the mover is an electronic counter that keeps track of how many times the jack screw has rotated around. This counter is "read" by a circuit in your receiver or motor controller and translated into a message you can read on your TV screen or on a LED display built into the controller. This read-out can be "software modified" to reflect specific satellites by name, degrees of azimuth (east-west movement) at any instant. A non-motorised dish requires far less "smarts" to make work first time, and if you select a Polar Mount design, a motor can always be added later. See SPACE Pacific Report, #9910.

## ADVANCED INFORMATION

Polarotors and similar devices give you the ability to rotate the polarisation at the antenna feed with a remote control built into the receiver. The polarotor is a tiny motor driven device attached to a metallic "probe" - the real antenna in the receiving system. The motor, on instructions originating at the receiver (either from a memory load or as manually entered by the user), turns on and rotates a shaft with the probe attached.

The probe's relative position inside of the feed "throat" determines where it is peaked for horizontal or vertical reception from a particular satellite.

Not all 'polarotor' (tm) devices are of pristine quality. Some have unfortunate signal loss (fixed by throwing it away and getting a new, better quality device), some tend to wear out. A common problem is where the motor "jumps," "jitters," or "modulates" the received signal with a black "hum bar." There are fixes you can do to improve the performance of the motor drive part. Start by identifying the +5V line as it attaches to your receiver (typically the red wire). Now identify the ground connection (see above) for the polarotor connections on the receiver's rear deck. Between the two place a 470 up to 1,000 uF ceramic disc capacitor. This will improve the isolation between the two. Next, identify the +5V line again and place a small (1/2 watt) carbon 1 ohm resistor in series with the +5V connection. Finally, if the motor is still acting up, try a 100 pF (that is picofarad) from the pulse input to motor ground. Or, **same connections at motor proper** are best choice.

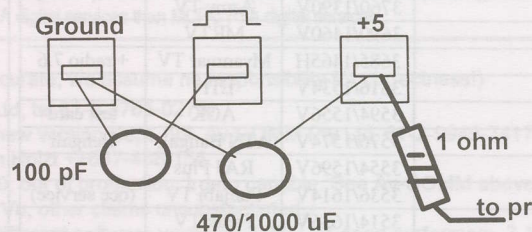

## TUNING IN THE INDUSTRY'S TV PROGRAMME

SPACE Pacific, the Asia-Pacific industry membership trade association, has produced (and continues to produce) a series of one hour television programmes. These "SPACE Pacific Report" shows, hosted by Bob Cooper, cover a range of topics of interest to installers and enthusiasts. Show numbers and content are as follows: #9901- Spectrum Analyser techniques, #9902- Feeds and LNBs, #9903- Dish antenna designs and problems, #9904- The dish marketplace, and, "tiny parts," #9905- Dr Overflow (Nokia) software, #9906- How the uplink works (tour of RCA's Vernon Valley site), #9907- Uplink Two, including uplink transmitters, #9908- Digital Basics (Mark Long), #9909- Real World Installs (Mark Long), #9910 - Installing a polar mount dish (in production); "Report" is broadcast by Mediasat on Optus B3, 12.336Vt, ad-hoc channel 3 (SR 30.000, FEC 2/3) with the following coming-weeks schedule: **Sunday November 21** - Show 9903 - 0300-0400 UTC (1600 NZDT, 1400 AESummerTime, 1100 Western Australia. **Sunday November 28** - #9904, same times as November 21; **Sunday December 5** - Show 9908, same times as November 21; **Sunday December 12** - #9909, same times as November 21; **Sunday December 19** - Show 9905, same times as November 21; **Sunday December 26** - #9906, same times as November 21. SPACE Pacific Report is also broadcast by Westlink, Aurora service on Optus B3, vertical (12.694, SR 30.000, FEC 3/4 - requires Optus Aurora card but is otherwise FTA). Schedule is Monday, Wednesday and Friday as follows: Mondays: 8AMWST/11AM AEST; Wednesdays 10AM WST/1PM AEST; Fridays 8AM WST/11AM AEST repeated 12noon WA/3PM AEST. Show schedule: Week **November 15-17-19**: Show 9903; week of **November 22-24-26**: Show 9904; week of **November 30, December 1-3**: Show 9905; week of **December 6-8-10**, Show 9906; week of **December 13-15-17**: Show 9907. Westlink goes into "hibernation" during the Christmas - January holidays, will return late in January (details in December SatFACTS - Shows 9908,9909, 9910 will follow). SPACE Pacific attempts to pre-announce which show(s) will appear through the SatFACTS Web site prior to each weekend (<http://www.satfacts.kwikcopy.co.nz>). Shows are digitally mastered and VHS copies are available from SPACE Pacific - see insert card between front cover and page 1 here.

Sponsorship of SPACE Pacific Report. In general answer to queries - AvComm, Satech and Sciteq have contributed corporate funding to make possible the production of the first set of ten SPACE Pacific Report programmes. Funds derived from sale of VHS tape copies are also an important element to meeting the \$1,300 overhead of each show. Mediasat and Westlink donate the time to broadcast the programmes, and both are to be commended for this support. As we move into the next group of (10) programmes now being scripted and shot, we solicit financial support from members of the industry with commercial activities they wish to have associated with the project. To discuss your own support, contact Bob Cooper at telephone 64-9-406-0651, fax 64-9-406-1083, e-mail Skyking@clear.net.nz. C-band wide area service is still being negotiated.



# WITH THE OBSERVERS

## AT PRESS DEADLINE

Additional 1701 RFO/Canal+ bouquet. As we go to press, apparently only unmodulated carrier is being transmitted. Signal level seems 3 dB low in Noumea, New Caledonia - which is boresight and possibly boresight is further west than it should be. Early days yet - updates <http://www.satfacts.kwikkopy.co.nz>.

ApStar 2R/76E: "CCTV-9 (English service) on and off at 3833/1317, SR 12.836, FEC 3/4" (Taylor, NSW)

AsiaSat 1/122E: "Test signals on 3677/1473Vt, 3933/1217Hz" (David Leach, NSW).

AsiaSat 2/100.5E: "Disagree (SF October) TVSN is weak - here it is best digital signal from As2, followed by Saudi 1" (D. Leach, NSW) - Are we talking about the same TVSN??? - ed.

AsiaSat 3/105.5E: "Alpha TV Punjabi is new on 3900/1250Vt, excellent signal" (David Hudson, Timaru, NZ).

ChinaStar 1/87.5E: "Feeds to Taiwan for TVRI and RCTI, analogue on 3880/1270Hz" (D. Leach, NSW).

Intelsat 701/180E: "Found signal on 11.610Vt November 5, first sign of new RFO/Canal+ bouquet. Measures 68.5 dBuV/10.5 C/N on 0.7dB noise figure Universal LNBF and 90cm offset" (Glen Makin, Brisbane). Parameters are 11.610Vt, SR 30.000, FEC 3/4 - ed. Newly activated occ. feed TVNZ channel at 4044/1106RHC, SR 5.632, FEC 3/4.

LMI AP1/130E: NTV/THT package parameters have changed - SR 12.000 now, FEC 3/4 on 3675/1475LHC.

JcSat 3/128E: Minor change in listed frequency - Miracle Net now 3996/1154Vt (TBN + others, SR12.997, FEC 5/6). "Test card is now at 4117/1033Vt, analogue P3" (D. Leach, NSW).

LM 1/75E: "There is an 'A' beam that includes Australian coverage, a 'B' beam which falls short. With 5m dish the B beam looks OK, on a 3.7M threshold extension is required. B frequencies of 3535/1615Hz and 3640/1510Vt" (David Pemberton, NSW). Also check 3459/1691Hz, 3619/1531 Hz, 3659/1491Hz - ed.

LMI AP2/142.5E: "They were testing 3675/1475 analogue again with test card, SECAM" (D. Leach, NSW).

Optus B1/160E: "New Sky NZ bouquet testing 12.671, SR 22.500, FEC 3/4 - 12 channels in all, FTA test cards initially" (P. Burton, Waipu, NZ). Yes - also check 12.643, same parameters for 8 channel bouquet, testing -ed. "Sky NZ has promo on programme channel 3 announcing terrestrial network TV3 will be there 01/01/00" (Jenkins, Auckland, NZ). "ABC NT feed did major upward swing in signal here - running 7.5/8 dB on 1.2m" (Stu McLeod, NZ).

Optus B3/156E: "Around 2AM October 21, most Aurora channels went down with announcement on ABC services advising service would restart at 2.55AM" (AI, Qld). "TARBS

**We apologise for this  
break in transmission  
and will return to normal  
programming as soon as possible.**

Y2K test? Major power failure in Sydney shutdown Foxtel, Austar for several hours (above). Are these guys ready for December 31st? *San Francisco* - Oakland Bay bridge looking east from ABC's KGO-TV HDTV feed sent as test on 1701 during October (below).



testing here within Mediasat on 12.336" (Howard, NSW). Mediasat is aggressively chasing new clients - they'd like to complete filling the first transponder so they can move on to a second one - ed.

**WITH THE OBSERVERS:** Reports of new programmers, changes in established programming sources are encouraged from readers throughout the Pacific and Asian regions. Information shared here is an important tool in our ever expanding satellite TV universe. Photos of yourself, your equipment or off-air photos taken from your TV screen are welcomed. TV screen photos: If PAL or SECAM, set camera to f3.5-f5 at 1/15th second with ASA 100 film; for NTSC, change shutter speed to 1/30th. Use no flash, set camera on tripod or hold steady. Alternately submit any VHS speed, format reception directly to SatFACTS and we will photograph for you. Deadline for December 15th issue: December 5 by mail (use form appearing page 34), or 5PM NZT July 6th if by fax to 64-9-406-1083 or Email [skyking@clear.net.nz](mailto:skyking@clear.net.nz).



### History of Norfolk Island's 10m dish revealed

"I have been absolutely engrossed in your September report concerning the Norfolk Island 10m antenna installation. And I take my hat off to Charles Shaw for his wonderful achievement. I always believed I would be called upon to install the 10m antenna, after all I purchased it and demounted the antenna from its' second home on channel 39 (WQRF-TV) in Rockford, Illinois (USA) in 1998. Here is some of the dish history. "This antenna was originally one of several 10m antennas manufactured in Cohasset, Massachusetts by RF

Systems Inc. That company was later absorbed into Comtech Systems of St Cloud, Florida. The antenna was created for the USAF as a radar antenna and was first installed at their Pacific Base in Guam. The antenna is the K.D. Astro Radial Design (model 103-10m -SP); the gearing on the tower is not really suitable for tracking. Next the antenna was demounted in Guam and shipped back to the USA where WQRF-TV purchased it and had it installed at Rockford. The third home for the antenna was originally to be a place known as Ellerstone near Scone in NSW. This plan failed to eventuate.

"Prior to this antenna being shipped from the USA to Australia, I discussed the antenna and its proposed new home with Thomas Christy and Glenn Higgins of Comtech Systems Inc. who recommended a conventional King Post Mount be adapted to the reflector; this would allow for C and Ku band tracking accuracy. I must say these chaps were extremely helpful and provided a full history of the antenna,

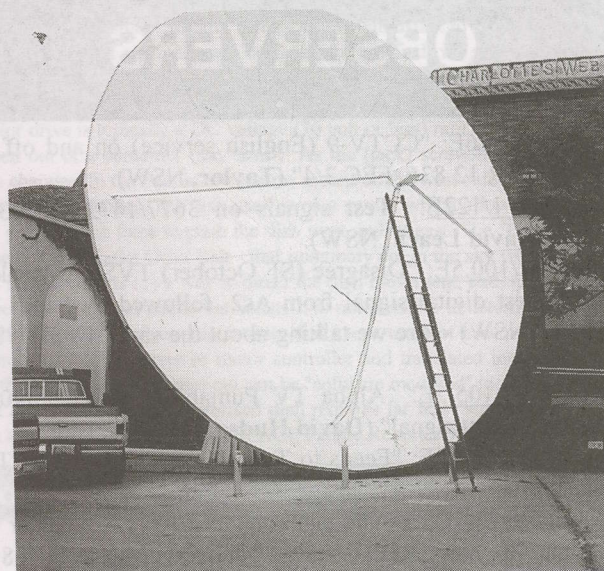

Coming down at WQRF-TV in Rockford, Illinois.



Lifting the beast in Illinois - it became known as "Mullane's White Elephant."

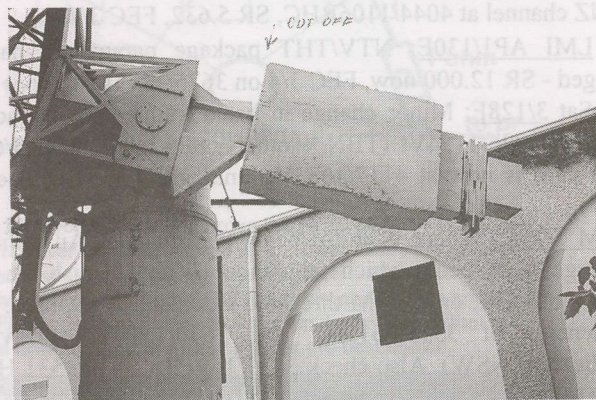

Original counterweight and balance plates before being oxy cut off in Rockford.

drawings for the correct mount for the antenna and its reassembly with a full set of details and foundation details. Glenn Higgins even volunteered to come to Australia to align the panels for installation in exchange for a set of aeroplane tickets.

"The original cruciform frame was not shipped along with the counterweight; they were oxy cut from the tower and scrapped in the USA. In Sydney a new cruciform frame was manufactured to support the antenna and RSJ fitted a counterweight box for concrete. Upon a close inspection in Australia of the pivoting elevation tubular frame that supports the cruciform it was discovered that most of the structure was badly rusted. Much of this was replaced but subsequently the tower and tower head were stored uncovered in the open and on its side in the Botany area of Sydney. Unfortunately this region is infamous for its acid rain content (many chemical plants in the



Lifting tower from foundation after oxy cutting cruciform frame.

area) and salty air from the adjoining Botany Bay Sea Terminal."

Ron S. Weatherall PhD AMIME.MIME, CEO, Professional Satellite Services, Sydney, Australia



# AT

## Sign-off

### What price a dish???

Sky New Zealand, Austar, Foxtel now buy 65cm dishes for under \$20. Quite a bit under, actually. Most of us suspect 65 (and 80/85) cm dishes are made in a giant cookie factory in Italy and even when a network pays as little as \$11 for it, the cookie company profits are huge. If you owned a cookie factory that sold 5 million of these things every year at \$5 profit each after all costs and overhead, you'd probably be a happy faced person.

Telstra, with the assistance of main contractor Ericsson, is turning under-\$20-cost 65cm dishes into a package of equipment for which they charge between \$1,326 and \$2,207 - installed. The installer gets + or - a few dollars of \$200 of this. This is the Big Pond satellite system (see pricing published by Ericsson, below).

There is a dish and mounting hardware, the LNBF, a not very generous allowance (20m) of RG6 Quad Shield cable, and for Telstra a PC card (called DAK) purchased from Hughes DirecPC. One could buy the DAK card for \$200 and that helps you figure out where the profit might be.

Add it up - \$200 to the installer, \$70 for the dish, LNBF, cable and hardware, \$200 for the DAK card. And we are shy of \$500. Of course that is before corporate overhead.

A one-man installer has corporate overhead. His vehicle, his test equipment, maintenance on both, his insurance (you do have insurance, don't you?). On his annual tax form, he may even stick a portion of his house on the expense roster in an attempt to cut down on the Government's share in all of this.

Now, in a purposefully unnamed Australian state where Optus has been trying to sell motels and hotels on a commercial package of satellite receiving equipment, we have another example of "corporate overhead." Before a motel can be an Optus programming subscriber, the facility must be rewired for multiple channel television. That includes as a bare minimum some modulators, a signal combiner, and some satellite receivers. When an Optus sales person gets a motel interested in the service, Optus asks a contractor to come in and "bid" on making the hardware installation less the satellite receivers. We've seen some bids that went from installers to Optus quoting prices in the range of \$1,000 for retrofitting the motel for satellite fed pay-TV. And we've seen

the same bids come back to the motel after being sent to Optus with a new price - like \$3,500.

There is value-added and there is Optus-added. The only thing Optus does when they review such a bid is to read it over and pass a glass of holy water above it. They add no new equipment, make no contribution to the installation.

So why - you ask - would Optus turn a \$1,000 hardware bid from an installer into a \$3,500 "formal bid" to the motel? The answer is "corporate overhead."

The bigger a company, the more difficult it becomes to control corporate overhead. Telstra has a list of overhead items that befuddle accountants and corporate managers. Retiring staff gets an annuity and that comes out of profits. Present staff have cars, offices bigger than the average home filled with expensive furniture, and \$500 lunches. It all adds up. Turning a \$20 antenna into a \$2,207 satellite installation (see table below) illustrates why big business is indeed big in every sense of the word. Adding "corporate overhead" to a motel satellite installation when the corporation has no involvement in the procedure except at most a few hours of somebody's desk time carries the process to a new level of mismanagement.

At the same time Ericsson+Telstra are collecting \$4,568 for a 1.5m dish installation in "remote" Australia, a half careful prudent buyer shopping on Internet or through industry catalogues can locate the same equipment for under \$600. And you have to notice that Ericsson charges \$3,590 for a 1.5m dish installed for a residence in remote Australia but adds \$978 for the same installation if the customer is "commercial" rather than residential. Does the installer get paid more money for a commercial job? Nope. Does the installer get more than the standard \$200 range fee if he works in a rural area rather than a city? Yes - about \$30 more. Should we all move to "rural Australia" and become contract installers for Ericsson? Probably not - they hire Comet to do the work nation-wide and if you have been paying close attention, Comet is placing their own corporate shares on the market November 22. Comet, in offering shares to present contract installers late in September, gave four reasons for going public. We especially liked number four:

"To demonstrate our standing in then business community."

Pardon me - I thought one did this by doing a good job, charging a fair price, treating employees with respect. Not by selling stock after joining the Australian Stock Exchange.

So there you have it. If you want to be a success in this world, figure out ways to increase your corporate overhead, then charge more to cover these costs and when somebody complains, offer to sell them stock in *your* company.

Dish	65cm	85cm	1.2m	1.5m	Existing Dish
<b>End User Price - Alternative 2: ONE OFF PAYMENT</b>					
<i>Residential / City</i>	\$ 1,326	\$ 1,349	\$ 2,319	\$ 3,441	\$ 1,023
<i>Residential / Rural Major</i>	\$ 1,399	\$ 1,422	\$ 2,379	\$ 3,463	\$ 1,023
<i>Residential / Rural Minor</i>	\$ 1,441	\$ 1,466	\$ 2,441	\$ 3,523	\$ 1,083
<i>Residential / Remote (1)</i>	\$ 1,483	\$ 1,507	\$ 2,505	\$ 3,590	\$ 1,207
<i>Commercial / City</i>	\$ 1,964	\$ 1,987	\$ 3,063	\$ 4,270	
<i>Commercial / Rural Major</i>	\$ 2,048	\$ 2,060	\$ 3,063	\$ 4,270	
<i>Commercial / Rural Minor</i>	\$ 2,134	\$ 2,144	\$ 3,191	\$ 4,418	
<i>Commercial / Remote (1)</i>	\$ 2,207	\$ 2,230	\$ 3,318	\$ 4,568	



# THE 1999 SATELLITE EXPLOSION IN THE PACIFIC/ASIA!

**Major Indian multi-language bouquet planned!**

**Stay tuned with SatFACTS!**

- ENTER my 12 MONTH subscription to SatFACTS starting with December 15th issue (rates below)  
 ENTER my 36 MONTH subscription to SatFACTS starting with December 15th issue (rates below)

NAME \_\_\_\_\_

Company (if applicable) \_\_\_\_\_

Mailing address \_\_\_\_\_

Town/city \_\_\_\_\_ Country \_\_\_\_\_

**Amount to send:** 1 year - NZ\$60(inside New Zealand) /A\$96 (inside Australia) /US\$60 (outside of NZ and Australia) or 3 years - NZ\$140/ A\$220/ US\$150 if by cheque. **VISA** or **Mastercard**? See form below and return with order. Return to: **SatFACTS, PO Box 330, Mangonui, Far North, New Zealand** or if by VISA or Mastercard fax to 64-9-406-1083

**IF YOU ARE IN AUSTRALIA - See AV-COMM Pty Ltd Advert p. 31!**

## USE THIS FORM ONLY WHEN CHARGING ON VISA/MASTERCARD

Please charge my **VISA/Mastercard** as follows:

- ONE Year of SatFACTS MONTHLY (NZ\$60, A\$96, US\$60)  
 THREE Years of SatFACTS MONTHLY (NZ\$140, A\$220, US\$150)  
 SATELLITE TELEVISION: The Booklet (NZ\$10, A\$12, US\$10)  
 One Year of COOP'S TECHNOLOGY DIGEST (NZ\$125, A\$125, US\$125)

Indicate charge card type:  VISA  Mastercard

Name (as it appears on **VISA / Mastercard**) \_\_\_\_\_

**VISA/Mastercard** Number \_\_\_\_\_ - \_\_\_\_\_ - \_\_\_\_\_ - \_\_\_\_\_

**VISA/Mastercard** expiration date \_\_\_\_\_

**Instructions:** If ordering by mail, return this complete (3-part) card or a copy of same (to **SatFACTS, PO Box 330, Mangonui, Far North, New Zealand**); if order by FAX, send full card as a single sheet to **64-9-406-1083**

**ALL COPIES OF SatFACTS Monthly are sent via Air Parcel Post world-wide!**

## SUPPLEMENTAL MATERIALS from SatFACTS MONTHLY: Order Form

- SATELLITE TELEVISION:** The Booklet. Excellent introduction to home dish ownership for the layman, including major contributions from the father of geostationary satellites - famed science fiction writer *Arthur C. Clarke*. The perfect tool to help the satellite system seller explain home satellite TV to the layman consumer. From SPACE Pacific. NZ\$10/ A\$12 / US\$10, airmail.
- COOP'S TECHNOLOGY DIGEST.** For the really serious enthusiast, investor, business person in satellite television and allied leading edge technologies. Ten issues each year, jam-packed with information you will not find anyplace else. "Coop" routinely culls more than 60 publications world-wide, terribly expensive newsletters, Internet and his hundreds of private contacts to keep you right at the leading edge of technology on the **REAL** changes underway in telecommunications. Conveniently issued near the **first of the month**, creating an excellent time-line-filler between the mid-month issues of SatFACTS. Now in the **6th year**, airmail world-wide. Normally NZ/A/US\$250 per year - for SatFACTS subscribers special **50% discounted** price of NZ/A/US\$125.



# OBSERVER REPORTING FORM - Due December 5, 1999

- NEW programming sources seen since November 1st: \_\_\_\_\_
- Changes (signal level, transponder, programming content) in pre-existing programming sources since November 1st: \_\_\_\_\_
- OTHER (including changes in your receiving system): \_\_\_\_\_

NOTE: Please use P1 - P5 code when describing signal levels and receiver IF/RF settings.

Your Name \_\_\_\_\_  
Town/City \_\_\_\_\_  
Make/size dish \_\_\_\_\_ LNB \_\_\_\_\_ Receiver \_\_\_\_\_

Your email address \_\_\_\_\_ if you have one!

RETURN: SatFACTS, PO Box 330, Mangonui, Far North, NZ, fax 64-9-406-1083, Email Skyking@clear.net.nz

## UPDATED for November - RFO/Canal + 1701 (clip and post)

Package of channels designed for New Caledonia, Vanuatu, Walls & Futuna (Islands) - available elsewhere subject to "clarification of programming rights."

Prices (as pre-announced) and services:

US\$64p/m: Eurosport, RTL9, Cartoon Net, Planete, MCM, RFM (music), Euronews (with English audio channel), TV New Caledonie (local to New Caledonia), Tempo and RFO-Sat.

US\$75p/m: All the above plus Cine Cinemas, TCM (movie service with English audio), Disney and 'XXL' (two adult films per night, starting at 11PM Sydney standard time).

US\$105p/m: All the above plus add Canal Caledonie (a terrestrial distributed pay-TV service linked here via satellite - 6 movies daily, major sporting events). Contact: Steffen Holzt tel +687-28 96 84.

**Technical parameters:** 11.610Vt (small chance of Hz), SR 30.000, FEC 3/4

**Equipment required:** In addition to Mediasat (with Mediaguard CA) IRD, appropriate 10.7 - 11.8 GHz LNB and feed, a dish. **What size:** Forecast footprints suggest the following: Noumea (New Caledonia) - 50 dBw/0.68m; Vanuatu - 48.5 dBw/0.82m; Brisbane, Norfolk - 47 dBw/0.9m; Fiji, Sydney - 45 dBw/1.16m; Melbourne - 42 dBw/1.61m; Wallis/Futuna Islands, Alice Springs, Cairns - 40 dBw/1.95m; North tip North Island (NZ) - 39 dBw/2.1m; Auckland, Solomons - 36 dBw/2.8m; northern portion South Island, NZ - under 30 dBw and not practical.

IS it just a COINCIDENCE  
Members of SPACE have more work  
than they can handle?



YES - send me information about how joining SPACE Pacific can lead me to more, profitable work!

NAME \_\_\_\_\_

Company affiliation (if any) \_\_\_\_\_

Mailing address \_\_\_\_\_

Town/city \_\_\_\_\_ postal code \_\_\_\_\_ Country \_\_\_\_\_



# Sky Vision Australia

*A Proudly Australian owned and operated company*



## SAT CRUISER DSR-101 MPEG 2 DVB / POWER Vu RECEIVER

***Latest Model – New Features  
Best value receiver in Australia !***

*Trade Price - quoted to established dealers*

- ✓ The ideal consumer orientated receiver with features that will please the enthusiast !
- ✓ Pre-programmed with all active TP's from Asiasat 2, Palapa, PAS 2 ,PAS 8 and more
- ✓ 10 spare user defined satellite positions for future satellite launches
- ✓ Simplified manual TP entry – TP Frequency is the only required parameter !
- ✓ Auto Symbol rate – Auto FEC – Auto PID's – Auto Polarity (LNBF)
- ✓ Satellite naming/editing – Channel naming/editing
- ✓ Alternate audio channels accessible from remote control
- ✓ On-board NTSC – PAL 50 Hz convertor – compatible with any PAL TV
- ✓ On-board Digital TELETEXT decoder – no need for Text capable TV
- ✓ 5 language menu - English (default) Spanish / Italian / French / German
- ✓ Consumer friendly graphical interface – Easy to install !
- ✓ UHF Ch 21-69 Software controlled RF Modulator – Low spurious emissions
- ✓ Low threshold dual bandwidth tuner – Dual SAW filter IF stage
- ✓ C Tick certified to comply with Australian Communications Authority standards
- ✓ Ultra reliable SMPS module – not a single reported failure to date !
- ✓ Full colour photographs and screen shots available from our web site
- ✓ 12 month replacement warranty – With an optional extended warranty plan
- ✓ Feel free to call one of our friendly staff for more information !

DSR-201P Analog/Digital/Positioner receiver ..*Trade Price - quoted to established dealers*

Export – Wholesale – Trade sales

Web Site: <http://www.bigfoot.com/~skyvision>

E-mail: [skyvision@bigfoot.com](mailto:skyvision@bigfoot.com)

Tel: 02 62925850

Fax: 02 62925890



# Millennium 2000

Full featured low threshold analog satellite receiver

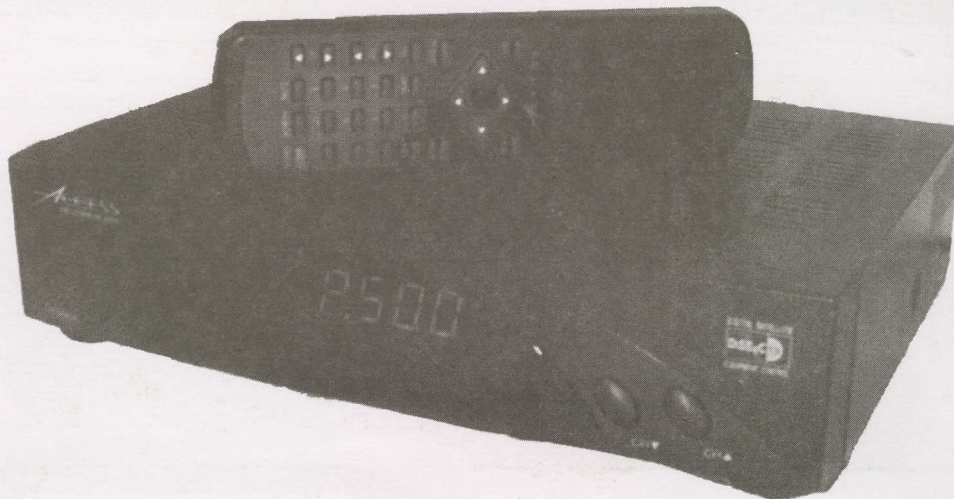

#### Features:

- On Screen Display 4 Language (English, French, Turkish, Arabic)
- 500 Channels Programmable
- 4 Digit display
- Favorite Channel Function (16 CH)
- Channel Copy Function
- Full Function Remote Control

#### Video:

- 32 Steps Low Threshold programmable
- Built-In Video Deviation Control Function (4 Steps)
- PAL/MAC/FILTERED/CANAL+ Decoder Interface

#### Audio:

- Switchable Audio Bandwidth (130/280/330/400KHz)
- 32 Steps Audio Volume Control Adjustable
- Multiple Audio De-Emphasis Control (50 $\mu$ SEC/75 $\mu$ SEC/J17/Dnr)
- Stereo & Mono all Audio Sub-Carrier (5.00~9.00MHz) receivable
- Panda-1 Compatible HIFI Stereo Super-DNR Sound Systems
- Audio Left & Right Individual Tuning System

#### Input:

- C/Ku-Band Switchable & Wide Band Tuner 900~2150 MHz
- 2 Input 2 Bandwidth (27/18MHz)
- Down-Link(Transponder) Frequency Direct Tuning System
- LNB L.O.F Select Function (5.150/9.750/10.000/10.750/11.000/11.475GHz & UNI-LNB-HI ,LO)
- L.O.F. Adjustable (+/-15MHz) Function
- Automatic Universal-LNB Control System
- LNB Pulse 22KHz & 60Hz Switching Programmable
- Diseqc 1.0 Built-in
- Multiple LNB control 0/12V Switchable
- Mechanical Polarizer

#### Output:

- 3-Scart In & Out & VCR Auto Loop Through
- 4-Phone Jack (Video, Audio L/R, Decoder)
- PLL RF Modulator 21 ~ 69 CH
- RGB D2-MAC Scart Interface Connection

#### Power:

- Switching Mode Power Supply ( 90 ~ 260VAC)

#### Dimensions:

- Small Chassis (280 X 200 X 65mm)

These quality products distributed by:



Phone: +61 8 9306 3738 Fax: +61 8 9306 3737  
sales@sciteq.com.au <http://www.sciteq.com.au>