

15-10-99-9AM

Bob Cooper's

OCTOBER 15 1999

SatFACTS

MONTHLY

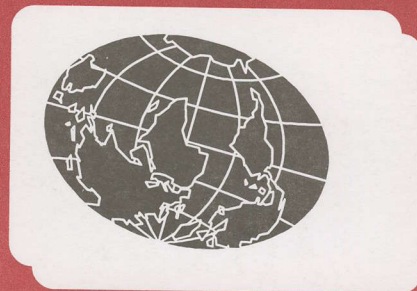

Reporting on "The World" of satellite television in the Pacific and Asia

IN THIS ISSUE

**Proper SMATV
RF distribution
Techniques**

**Piracy Supplier
MadMax goes to
jail in Bangkok**

**SPACE Pacific
Report now
on Mediasat!**

- ✓ Latest Programmer News
- ✓ Latest Hardware News
- ✓ Latest SPACE Pacific Reports
- ✓ Cable TV Connection

Vol. 6 ♦ No. 62
Price Per Copy:
NZ\$9/A\$10/US\$7

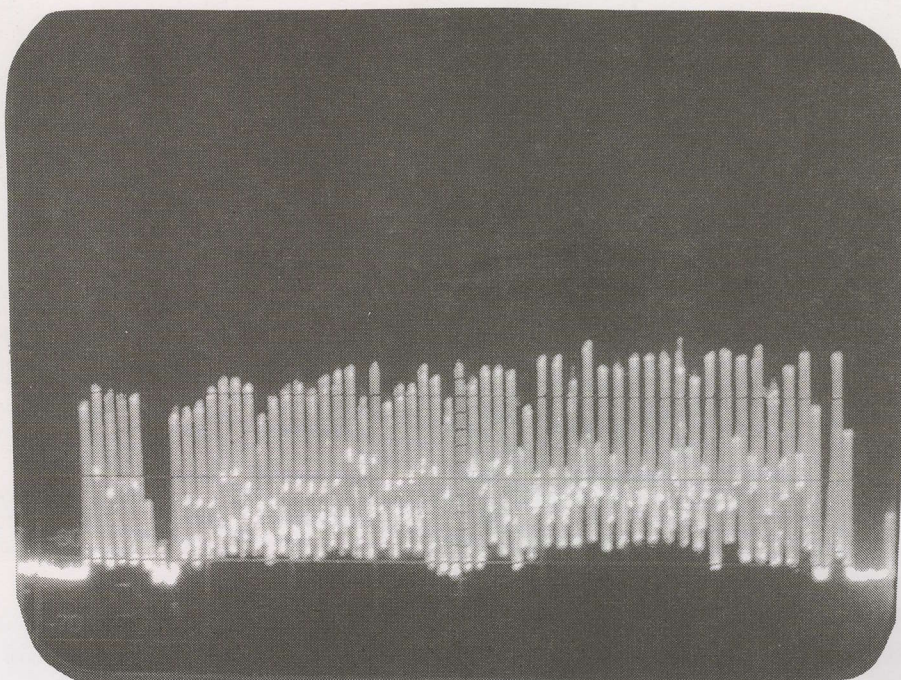

Paraclipse[®]

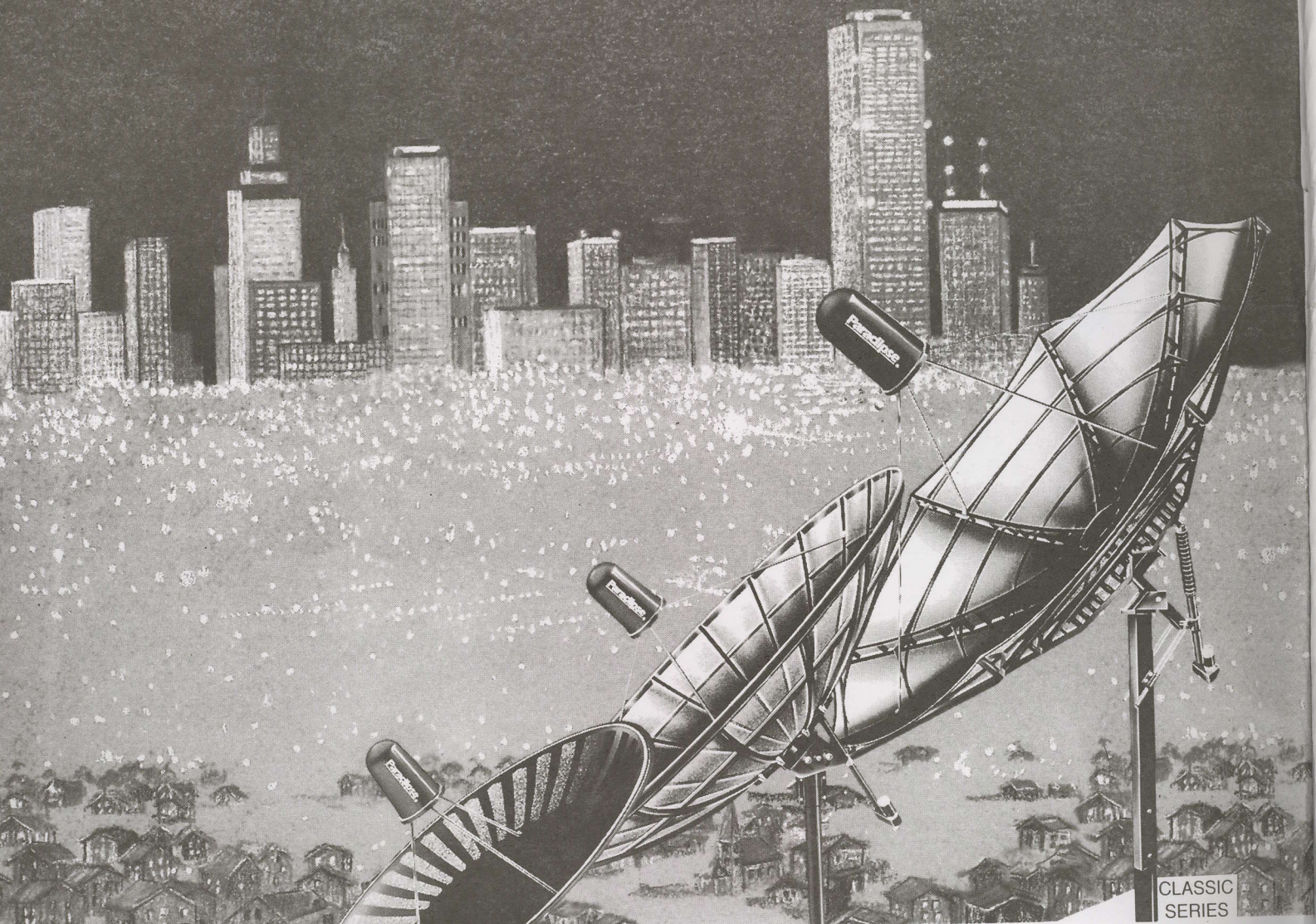

CLASSIC
SERIES

ECLIPSE
SERIES

HYDRO
SERIES

When quality, strength, and accuracy are your main requirements, **Paraclipse** antennas are your first choice.

Only **Paraclipse** offers such variety; four distinctly different series: the Truss-Ribbed Classic, the Courier Deliverable Eclipse, the Stretch Formed Hydro, the Commercial Patriot.

Every **Paraclipse** model sets the industry standard in its class, worldwide.

Distributed in Australia & the Pacific by

**SATECH Satellite
Communication
Technology Pty. Ltd.**

18/477 Warrigal Rd, Moorabbin
East, Victoria, Australia 3189
tel 61-3-9553-3399
fax 61-3-9553-3393

Paraclipse[®]
HIGH PERFORMANCE ANTENNAS

Paraclipse Inc.
2271 29th Avenue East, Columbus, Nebraska USA 68601
Telephone: (402) 563-3625 Fax: (402) 564-2109

★ **MADE IN
AMERICA**

SPACE PACIFIC REFERENCE MATERIALS

(updated October 15, 1999)

to help you do a better job, profitably

Some items in limited quantity (marked LtdQty); many have special SPACE member discounts

SPACE Pacific Report (# 9901, 9902, 9903, 9904)

The television programme, direct to you from digital master on E240 VHS tape, PAL format of course. Show 9901: "It is your signal, too" and "Fun and games with the spectrum analyser." Show 9902: "Feeds and LNBS" - understanding how products differ. And, "Mark Long's Thumbnail History of home satellite TV" featuring the real pioneers of the 70s and 80s! Show 9903: "Dish antenna critique," why some dishes work better than others, plus Mark Long on installing your own dish, and, Richard Brooks on PVRs. Show 9904: "Who buys DTH systems?" explores the marketplace, plus, "Understanding Tiny Parts" looks at connectors, line-amps and splitters. Four hours as currently running on Mediasat - digital mastered to you for the exceptional price of \$55 including shipping and two bonus items - "Satellite Television (The Booklet)" featuring material by Sir Arthur C. Clarke, and, the infamous CMT satellite pencil-writer! (see order form, below). In stock, shipped within 72 hours. (No SPACE discount)

Shows 9905, 9906, 9907, 9908 & 9909

The television programme - the latest releases (even before they appear on Mediasat!). As above. Show 9905: Robin Colquhoun illustrates the Dr Overflow software for the Nokia; Show 9906: How the uplink works - possibly the best programme topic ever created. Show 9907: Part two of uplink. Show 9908: Instructor Mark Long's "Digital Basics." Show 9909: Mark Long's "Installation Basics" with emphasis on Ku service. Shows 9905, 6, 7, & 8 now being shipped. \$60, no SPACE discount.

World Sat TV '96

If you are new to satellite TV, are not sure about the difference between the LNB and LNBF, or what vertical and horizontal means - this is the self-learning book for you. Written by Mark Long, it takes you from total novice to satellite expert in 13 well illustrated, carefully explained chapters. Originally written for Asia & Middle East, this 1996 version heavily discounted at \$15 (LtdQty); SPACE discount applies.

World Sat TV '92

Essentially the same book as World Sat TV '96 but released four-years earlier. All of the basic fundamentals are here, at a price that is too good to be true. Hey - the quantity is very limited (LtdQty) and we need to clear out the shelf space. \$10 and if you are a SPACE Member, it comes down 30% to \$7! Having a complete satellite TV reference book doesn't get any cheaper than this.

TB 9404 DTH Systems

Direct to Home: Satellite System Installation Techniques. Without question, the very best quick tutorial on what a home dish system is, how it works, where the problems develop. If you are new to the DTH field, buy this and commit it to memory. Very slight New Zealand bias, not enough to hurt its value world-wide. Prepared by Coop for an Asian DTH technology conference, LtdQty \$10 (SPACE discount).

TB 9405 SMATV Systems

Satellite to room - Commercial SMATV (Satellite) Dish Installations. The easy part is the satellite dish or dishes. The difficult challenge is getting all of those signals - including the terrestrials - balanced and into every room and each TV outlet at the proper level. If you plan to do multiple-outlet systems, start here with this Coop written tutorial. LtdQty and only \$10 per copy while they last! (SPACE discount)

Nelson Parabolic Manual

The Nelson Parabolic TVRO Manual. If you are the type of person who wants to build your own dish (up to 3.7m in size), or, you simply want to understand why some dishes work better than others, this step-by-step "how to build a dish" manual is the "Bible" of an industry. Nelson Ethier was a perfectionist and brilliant with hand tools. It shows here - the ultimate backyard project! Half original price at \$15, LtdQty, SPACE discount applies.

SPACE Pacific Order Form (also see SPECIAL PACKAGES on reverse side)

Please send the following:

SPACE Pacific Report - 9901-9904/ \$55 (no discount); Shows 9905-9908/ \$60 (no discount); Package deal - 9901-9908 (2 tapes)/ \$105 (no discount); World of Sat TV-'96/\$15; World Sat TV-'92/\$10; TB 9404 - DTH Systems/\$10; TB 9405 - SMATV Systems/\$10; Nelson Parabolic TVRO Manual/\$15. Total of order - \$ _____. If current SPACE member, multiply by 0.7 (70%) and write discounted total here: \$ _____

I wish to pay this by cheque (enclosed) VISA card Mastercard

Card number _____ expires ____/____

Ship to (name as it appears on card):

Company _____

Mailing address _____

Town/city _____

Your signature: _____

SPACE Pacific Terrestrial TV Reference Materials

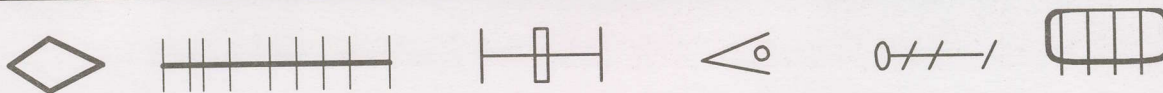

Each of these editions researched, created by "Coop" to help you solve tough aerial problems

**TB
9301**

Tech Bulletin 9301. Co-Channel & Antenna Phasing. How to grow a single antenna (Yagi, broadband antenna) into a complex array to greatly increase gain, sharpen receiving pattern to eliminate co (same) channel interference. Totally hands-on, very practical, up-to-date. Go from novice to professional!

**TB
9302**

Tech Bulletin 9302. Weak Signal Reception Techniques. If one cut-to-channel (Yagi) antenna won't do the job, will 2, 4 or 8??? How about 16? Stacking antennas, mating with carefully selected masthead amps, is an art. This explains how to do it for professional results up to 300 km from TV stations.

**TB
9303**

Tech Bulletin 9303. UHF - The Frontier. Using parabolic style antennas surfaced with low-cost poultry mesh, build UHF dishes up to 40 feet in size to extend UHF off-air reception out to 300 km. And - learn the tricks to "squirt" signals from a hilltop to a valley below using low-cost receiving equipment.

**TB
9304**

Tech Bulletin 9304. Beating Noise Interference & Combining Cross-Pole Signals: When TV and FM signals are weak, man-made interference from appliances, power lines can kill reception. Step-by-step instruction for identifying, locating, fixing noise sources + unique method of combining cross-pole TV signals.

**TB
9305**

Tech Bulletin 9305. Cable Television - Fact & Fiction. The story of how a cable TV system is designed, built, operated. The perfect "So this is how it works!" report. Who knows - you might even like the concept so well you take out a mortgage on your home and wire your town!

**Lost
Art**

Lost Art of Rhombic Antennas -27 dB of gain VHF & UHF. Everything you need to know to build the most sensitive VHF-UHF receiving antenna ever created. Rhombics are used for virtually all long haul military circuits. Includes super-Rhombic LaPorte design. 300 km? A piece of cake!

**40'
Dishes**

20 to 40' Poultry Mesh (Chicken Wire) Parabolics. Complete instructions to build UHF-TV off-air reception antenna system combines low cost reflector materials with Redwood or other durable "struts." 20 to 25 dB of gain, out to 300 km UHF reception. A backyard project with earnings potential.

**Half-
Bolics**

World-Famous Frias Half-Bolic Reflector. Amazing design allows simultaneous reception over sizeable arc of transmission locations. City grade (80 dBuV) reception from distances of 280 km on VHF (45 MHz) through UHF (900 MHz). This is huge, but easily the best all-around deep-deep fringe antenna system.

**Raw
Video**

SPRSCS '99. SPACE shot many hours of video during SPRSCS '99 to prepare for the (now available) 9901 - 9904 one-hour TV shows. In "Raw Video" you have everything shot, before editing, including material done by Robin Colquhoun for the Dr Overflow software explanation - all reshoots and mistakes! 4 hours, PAL.

ORDER FORM - and special discount packages

Please send the following:

- TB 9301/\$10; TB 9302/\$10; TB 9303/\$10; TB 9304/\$10; TB 9305/\$10; Lost Art-Rhombic/\$20; 20-40' Dishes/\$20; Frias Half-Bolic/\$20 - or
 TB9301/9302/9303/9304/9305 - \$40 -or- Rhombic/ 20-40' Dishes/ Half Bolics - \$50 -or-
 TB9301/9302/9303/9304/9305 + Rhombic/20-40' Dishes/Half Bolics - \$80.

Video: Space Raw Video/\$35; SPACE Videos - 9901-9908 + Raw Video/**3 tapes** \$135.

Total of order - \$ _____; If current SPACE member, multiply total by 0.7 to obtain discount price (NOTE: No discount applies to Raw Video or SPACE Pacific Report) - new discount total \$ _____. I wish to pay this by Cheque (enclosed) VISA Mastercard

Card number _____ expires ____/____

Ship to (name as it appears on card)

Company _____

Mailing address _____

Town/city _____

your signature _____

Return to: SPACE Pacific, PO Box 30, Mangonui, Far North, New Zealand or fax to 64-9-406-1083

SatFACTS MONTHLY

ISSN 1174-0779

is published 12 times each year (on or about the 15th of each month) by Far North Cablevision, Ltd.

This publication is dedicated to the premise that as we enter the 21st century, ancient 20th century notions concerning borders and boundaries no longer define a person's horizon. In the air, all around you, are microwave signals carrying messages of entertainment, information and education.

These messages are available to anyone willing to install the appropriate receiving equipment and, where applicable, pay a monthly or annual fee to receive the content of these messages in the privacy of their own home. Welcome to the 21st century - a world without borders, a world without boundaries.

Editor/Publisher
Robert B. Cooper (ZL4AAA)
Office Manager
Gay V. Cooper (ZL1GG)

Reaching SatFACTS

Tel: 64-9-406-0651
Fax: 64-9-406-1083
Mail: PO Box 330
Mangonui, Far North
New Zealand
Email: Skyking@clear.net.nz
<http://www.satfacts.kwikkopy.co.nz>

Subscription Rates

Within NZ: \$60 p/y
Australia: AV-COMM Pty Ltd, PO Box
225, Balgowlah, NSW 2093
61-2-9949-7417
Elsewhere: US\$60 p/y
All copies sent via airmail fast post
world-wide

ERRATA

SatFACTS Copyright 1999 by Robert B. Cooper; any form of copying is a violation of our international copyrights. Advertising rate sheet available upon request.

COOP'S COMMENT

I suggest you read pages 14-15-18 and 20-21 before reading this. Unless you are a person who reads the final chapter in a novel before starting at the front. This is your last warning - stop now.

The "Saga of MadMax" could make an interesting novel one day. Australians may liken him to Ned Kelly or Captain Moonlight - two notorious bushrangers who made a mockery of the federal police until done in by compatriots. Ned Kelly is remembered by a ballad, Captain Moonlight hardly rates a post script in contemporary history books.

Rolf Deubel (the name on his German passport) made *verification* of his arrest by Thai members of the Economic Crimes Investigation Division (ECID) complicated. Mindport (Irdeto) in an advisory to SatFACTS September 21 wrote, "*Over the past few months we have been working with a number of organisations monitoring Madmax and his affiliates. This activity culminated in Bangkok last week after Madmax travelled from his home in Cape Town - to record the (Thai) UBC transmissions (in Bangkok).*" Problem one - the name on his passport. Why important? Because it is nearly impossible to verify the arrest of someone unless you know the name under which they have been arrested. Calls (plural) to the ECID in Bangkok - with numerous language problems of course - told us repeatedly, "*Nobody from any country under any name has been arrested nor is being held for investigation relating to (television) piracy cards.*"

A friend of MadMax we located with some difficulty in Europe casually mentioned, "he is German." Was it possible he was using a German passport? In what name?

Mindport Solutions Australia finally advised after repeated questions from us, "*To our knowledge, Rolf Deubel is his real name.*" Next stop - the German Embassy in Bangkok through their Emergency Assistance number; Thai law requires when a foreigner is arrested that their embassy be notified within 48 hours. A lady speaking German, not pleased we had rung her on a Sunday, expressed surprise that we would be asking about Rolf. "*He was arrested sometime ago - this is NOT an emergency!*"

Tell that to Rolf - after 24 days in some unmarked Thai jail.

OK - so he was arrested and his name is Rolf Deubel. Or at least that is what his passport says. What next? The ECID was still denying they have any "*active investigation*" ongoing, nor anyone in custody.

His "affiliates" (Mindport's description - not ours) are card modification guys and gals. None showed any interest in talking with me, even after I suggested that if they were really friends of Rolf, they would try to do something to at least get him legal counsel in Thailand. We also asked if anyone had thought to console his wife and daughter in Cape Town, to see if his home office had been "ransacked" by "burglars" after his arrest in Bangkok. Serious guys chasing information about the piracy world would be looking for computer discs and hidden files, we suggested. I finally got the attention of one of his European friends when it was pointed out, "*Look - your name, and a record of his contacts with you could be stuck away on a disc in his laptop PC that the ECID confiscated when he was arrested. Or still in his home or office in Cape Town.*"

"*You mean they could come and get me - too?*" asked the synthesised voice on the phone? In my mind, this electronically altered voice I was listening to was probably originating at a pay phone (fone) in Belgium or France - a phone in an obscure location with no surveillance cameras - and the call was being paid for with a pirate phone card!

"*Talk to me*" said I, "*or I may be writing about your arrest next.*"

Post script: No, this story is not complete; <http://www.satfacts.kwikkopy.co.nz> for updates.

In Volume 6 ♦ Number 62

RF Distribution - Adjacent Channels is not a no-no -p. 6
MadMax arrested by Thailand special police, in jail -p. 14

Departments

Programmer/Programming Update -p.2; Hardware/Equipment Update -p. 4; SPACE Pacific Report (Death of a hacker) - p. 20; Cable Connection (Outfitting for a new Ku-band) - p. 22; SatFACTS Digital Watch -p. 24; Supplemental Digital Data -p. 26; SatFACTS Analogue Watch -p. 27; SPACE Pacific Report - TV Show schedule -p. 28; With The Observers -p. 29; At Sign-Off (Blackspot report) -p. 32

-ON THE COVER-

Each of those CRT blips is a separate TV channel - all sharing the same cable (p. 6).

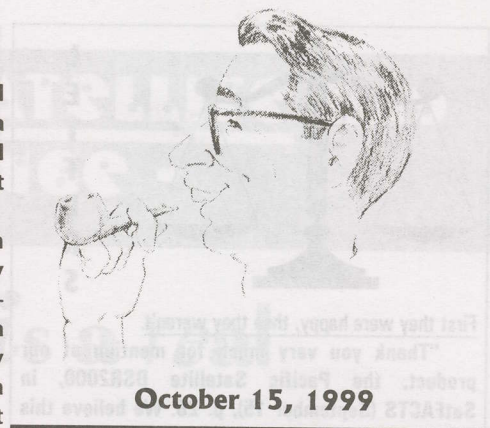

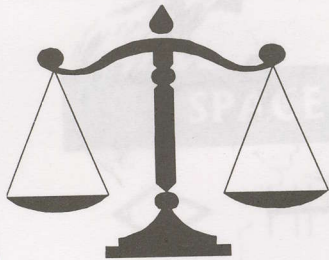

L
E
T
T
E
R
S

First they were happy, then they weren't

"Thank you very much for mention of our product, the Pacific Satellite DSR2000, in SatFACTS (September 15), p. 26. We believe this listing is a way to get more and more people to know our products. However, we wish your magazine would not introduce our Pacific Satellite DSR2000 as a 'clone of MediaStar D7,' especially when MediaStar has a one page advertisement in your magazine. With it stated this way, our present and potential clients could be misled to the 'other' company. All of the best to SatFACTS."

Cindy Wu, Pacific Satellite, Queensland

Our response was that with a DSR2000 and the MediaStar D7 side by side, it is immediately clear the only thing different between the two is the corporate labelling. And since MediaStar had their D7 months



before Pacific had their DSR2000, we reasoned the DSR was a second-source "clone" of the D7. And we told Cindy Wu this and then pointed her to Coop's Comment (p. 1) of September dealing with companies who operate around the periphery of this industry but fail to participate in any real industry activities - such as showing their support for SPACE, advertising in SatFACTS or otherwise doing anything other than taking people's money for products. Which led to: "Currently our Hong Kong headquarters' policy is for major marketing in Europe and Middle-East, not in Australia and New Zealand markets. As for the DSR2000, please remove it from your product list (as) it already fades out (to be) replaced with the DSR3000."

The premise behind the page 26 listing is to provide identification and where practical support information for any IRDs commonly available in the Pacific. That includes older products no longer sold but still requiring support. If you say the DSR2000 has been discontinued, our listing will reflect this but for those who need service, that it is a "clone" of the MediaStar D7 may help someone out of a tough spot as well. And we suspect the industry will "remember" less than full industry participation put forward by Pacific Satellite when they bring their next clone to market.

PROGRAMMER
PROGRAMMING
PROMOTION

UPDATE

October 15, 1999

ABC pulls it in. "NT" service (12.256Vt, B1) was salvation for "offshore" viewers without access to Aurora platform. More recently, Central 7 on 12.354Vt has been added but their coverage pattern has resulted in no ex-Australia reports. During third week of September, ABC service ran up and down in level for a few days, then dropped out for most non-Australian viewers (4m dish now required in NZ).



RFO pulling it in. The RFO Tahiti 1701 bouquet (4095/1055LHC) which has been difficult to receive in NSW and many other portions of Australia will get more difficult on February 1. They plan to reduce the bandwidth, cut back on the eirp, and go from three to two French-origin feeds there. Why? Because around 1 November New Caledonia is scheduled to begin testing a new 1701 Ku band spotbeam service which will have 13 programme channels on board - including 3 RFO services that will be FTA (the other 10 will be CA, including "hard-core" French XXX adult service). Price? Around A\$110 per month. IRDs? Mediasat with imbedded Mediaguard CA system - a purpose-design unit believed manufactured by Sagem (France). Can you receive it? See detail on insert card, middle p. 34 here. Can you subscribe to it from Melbourne or Cairns? Is the sky blue? Who to contact? Antenne'cal Communications at fax ++687-41-52-40, email antenne-cal@canl.nc. Is this "another" of those New Caledonia hype deals? No, this one is for real.

Men are just boys with bigger toys department. State owned telecaster TVNZ (New Zealand) has decided it will combine conversion to digital (from analogue) with additional pay-TV programme channels, and maybe 2.1 GHz MDS/MMDS frequencies. Private, Murdoch-News Corp controlled Sky Network, not pleased with threat of competition, responded by going to TVNZ competitor TV3/4 and signing them up to be part of Sky's satellite digital package. TVNZ then retaliated by yanking their newscasts away from Sky causing Sky's headman Nate Smith to tell the press, "We were going to dump TVNZ news anyway." Smith went on to tell press, "It wasn't out of concern (about what TVNZ did), we're just trying to teach them (TVNZ) some civility" (manners). In same week period, Smith's Sky decided they would not go through with purchase of 30% interest in NZ ISP IHUG - and IHUG responded by launching 12-15 channel terrestrial 12 GHz delivery service to compete with Sky. Confused? Don't be - it's just another episode of 'SOAP'!

KIBC shuts down - taking SPR off air. Subic Bay, Philippines based KIBC, carried on AsiaSat 2, shut down permanently at 6PM Hong Kong time October 1 - citing "a lack of advertising revenue" as the reason. With it went the 8 weekly showings of SPACE Pacific Report - the TV show. The good news (some will consider it better - especially those with small dishes in Australia and virtually everyone in NZ) - there is a replacement - Mediasat on Optus B3. Details on pages 23 and 28 here.

NHK - has made major improvement in "NHK World TV" service October 1 - "nearly all news programmes on the domestic network will be broadcast simultaneously." Weekend - sports programming and "regional" NHK programmes.

Home grown. SPACE Installer member Pietro Casoar wrote, directed and appears in newly produced SPACE Pacific Report (possibly 9910) showing how to assemble, install and track 3m+ size dishes. Helping - Joe Bonavia of IKUSI Australia with their new Promax Prolink 3. The SPR library grows and grows (now Mediasat Sundays).

IF YOU THINK DIGITAL SATELLITE HAS BEEN A CHALLENGE -

DVB-T in HDTV is a real eye @pener!

What the professional broadcasters are saying about HDTV:

Andy Setos, VP of Technology for Fox Network: "It stinks. But we believe it can be fixed. What we have learned in side by side testing of COFDM versus 8-VSB is that (present day) COFDM implementation is better than 8-VSB, not that 8-VSB cannot be made to work.

Executive at Zenith, developer of 8-VSB: "The Australian tests (of COFDM versus 8-VSB) were flawed by virtue of what they did not test, not by what they did test."

Bruce Jacobs, former head of PBS Network Engineering: "In the fringe areas, 8-VSB and COFDM were virtually identical. In urban areas, COFDM worked well, 8-VSB did not work at all."

Digital TV dealer in San Francisco: "In downtown (San Francisco), analogue reception is good but digital reception drops in and out with every passing street car and truck."

Nat Ostroff, VP Technology, Sinclair Broadcasting: "A fundamental egregious mistake was made when DTV was tested and the testers assumed all viewers would be utilising an outdoor, rooftop aerial for (digital) TV reception. Tests to date with indoor set-top antennas have been a miserable failure."

Australian report on their COFDM versus 8-VSB tests: "Around 30% of Australians watch FTA using indoor antennas. No testing was done with indoor antennas."

What we have shaping up here is a disaster. TV broadcasters will operate their terrestrial analogue services (in parallel to the new digital transmissions) only for a set period of years - then analogue will be switched off and only digital will continue. Driving this switchover will be consumer enthusiasm for and acceptance of digital TV receivers as a replacement for their present analogue TV sets. All evidence to date says the digital terrestrial system has serious flaws. Where to from here?

SEND ME THE COOP-SCOOP ON THE DIGITAL TERRESTRIAL DISASTER (Comprising Coop's Technology Digest for September 15, October 8)

ENCLOSED my cheque for NZ/A/US\$25 for airmail delivery of CTD's special twin reports on the Terrestrial Digital television mess -

CHARGE my VISA Mastercard _____ - _____ - _____
with card holder name of _____ expires ___/___

Send airmail to:

Name _____

Address _____

Town/City _____

Return order to: SatFACTS Monthly, PO Box 330, Mangonui, Far North, New Zealand
or fax order page to ++64-9-406-1083 or e-mail to Skyking@clear.net.nz

Different views

"I thank you very much for creating SatFACTS and pushing for the further development of the TVRO industry in the Pacific-Asia region. I am very pleased with your spirit! I am interested in Chinese TV services and would like to purchase an IRD and smart card for the SPACE TV service off of Palapa C2. Is there a contact for this?"

Jason Wu, NZ

Try Ming Leu at NetSat in Australia - tel 61-2-9687-9903, fax 61-2-9687-9906 or email mleu@rivernet.com.au.

"Your editorial in issue 61 reminded me of an old friend's speech. Elsie Wayne was the mayor of Saint John, New Brunswick and every year the Port of St John put on a fabulous dinner for people in New York who routed their goods through the Port. 'Thank you' she said in her speech, 'for shipping through our port. I know the Bay of Fundy tides make it difficult and we are not as close to the rail line access to Montreal and Toronto as you might like - so thank you a lot for doing business with us. And for those of you who have enjoyed our lobster and don't do business with us - I hope you choke!'"

KClark

"Gee Bob you print some crap sometimes. I have just been reading Coop's Comments in the September issue of SatFACTS and the tears of laughter are rolling down my face."

Robin Colquhoun, Auckland, NZ

Is it possible to choke on your own tears?

Support for SPACE Pacific TV Show on KIBC

"Dear Vince Waterson - Thank you for allowing air time for the SPACE Pacific Report on the KIBC satellite television channel. As a dealer member of SPACE Pacific, I greatly appreciate the programmes of news and installation tips which you are allowing us program time to distribute."

Gary Salisbury, Kan Sat, Gunalda, Qld.

"Dear Sir - Since KIBC has been broadcasting SPACE Pacific Report, there has been a sudden interest by the public in your channel. Everyone I have installed a digital system for has called me up to have KIBC programmed into their receiver so they can view the weekly program. This in turn has created increased interest in other KIBC programming and is quite often accessed each day by my clientele because of the English language content. Report is THE essential program for not only people in this industry but also for the average dish owner because it informs and enlightens the viewer of what would be the best way to approach satellite television system design and use. Thank you for making this possible!"

Pietro Casoar, DigitalSat Communications, Victoria

We encouraged anyone with access to email to compose letters to Vince Waterson, KIBC's head guy, and show support for the continued presence of SPACE Pacific Report on this channel. Unfortunately, KIBC has closed down but SPR is now on Optus B3 Mediasat each Sunday thanks to support of Paul Mullen and efforts of Av-Comm's Garry Cratt. By the way - shows 9905 (Dr Overflow), 9906 (Part one of TT&C uplink tour), 9907 (Part two of uplink tour), 9908 (Mark Long on digital installs), and 9909 (Mark Long on proper installation techniques) are now running.

HARDWARE EQUIPMENT PARTS

UPDATE

October 15, 1999

That cake. In SPACE Pacific Report 9907, guest host Paul Burton of Waipu Cable TV picks up a single layer cake covered in white frosting bearing the stylistic logo of American firm "RCA." And plants it squarely in Coop's face. 20 years prior, in an American TV show cable TV association President Ben Campbell did the same thing to your editor. All part of the "fun 'n games" associated with the RCA "Uplink Tour" currently running on Mediasat on weekends. The cake here? This is what remained after planting in Coop's kisser (see p. 28).

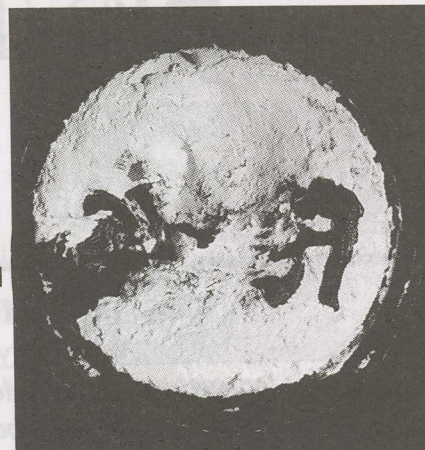

Humax F1-CI receiver. Big mystery. Does it do Aurora and Foxtel and Austar and PowerVu (and on and on)???? Grant Tormey, authorised dealer for R.G. Electronics, says, "I have personally seen it work on all of these and it can switch from free to air to pay-TV without a problem." Grant further advises that Optus has now added the Humax IRD to the "Aurora approved list - the first and only CI unit to be on that list." If true, and Grant has been told this by R.G. and has not seen it in writing yet - Humax sales should zoom from this point onward.

Leonids Meter Shower - phase two. 1998 was a bust, also was erroneously identified as "peak year." This year - November 18th is forecast peak this year but could be day earlier. Most in danger, satellites in 110E to 0E region including the AsiaSats. Maximum impact region will be Middle East, eastern Europe.

Correction: Big Pond Advance, Telstra's Internet download service at 400 kbps, is only on PAS-2 at this time - not PAS-8 nor any Optus satellite. Service offers Turbo-Internet through normal dial-up modem, or Package Delivery/Turbo Webcast as receive only terminal. Users dial Big Pond, are linked to satellite server complex in Sydney. Downloads requested are located at server complex, sent to Bendigo and thence to PAS-2. Nominal user dish size is 85cm but larger dishes are required in some areas. User installation cost is \$1500-\$1600 range, Comet is the contractor where installers are paid between \$190 and \$210 per job. Service is actually USA bred DirecPC, complete with Hughes service logos.

Just being different. SBS has selected NDS to expand the distribution of four channels of SBS programming, including two NDS multiplexes, eight E5610 encoders. Broadcasts originate in North Sydney where television and radio programmes are digitally encoded with the E5610 2U encoders. Output from the NDS multiplex is carried via the Optus TM network to Belrose where it is fed into a third multiplexer and uplinked to the Aurora B3 platform.

Digital format signal/BER meters? Still delayed although Peter Lacey's SBM-105 is in transit to SatFACTS for review and description, Ikusi versions are expected shortly - and the Spanish built, English sold hand held BER indicators are someplace between the UK and the Pacific. One problem - early versions of everyone's machine would not readily receive SCPC rates, a problem we suggested be corrected before products are offered in Pacific.

Ku-band LNB/LNBs for the new I701 RFO/Canal+ service (p. 21, 34) will be in short supply initially - better start your own quest now for that first one to test the signal after November 1st.

ADL[®]

BECAUSE PERFORMANCE IS ALWAYS YOUR FIRST PRIORITY

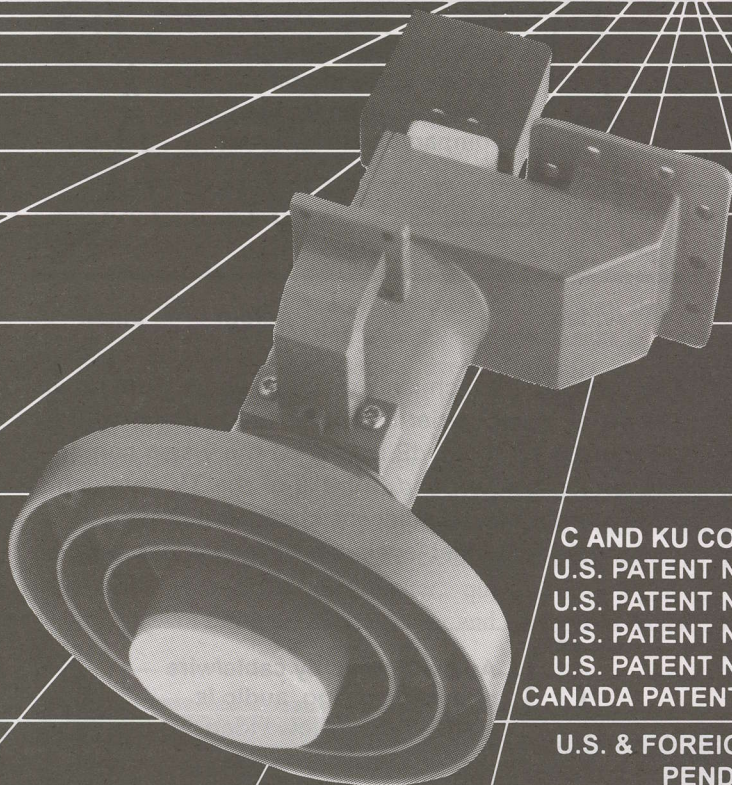

**RP3-CKU/ International
Adjustable Scalar Ring Feed
with Extended C Band**

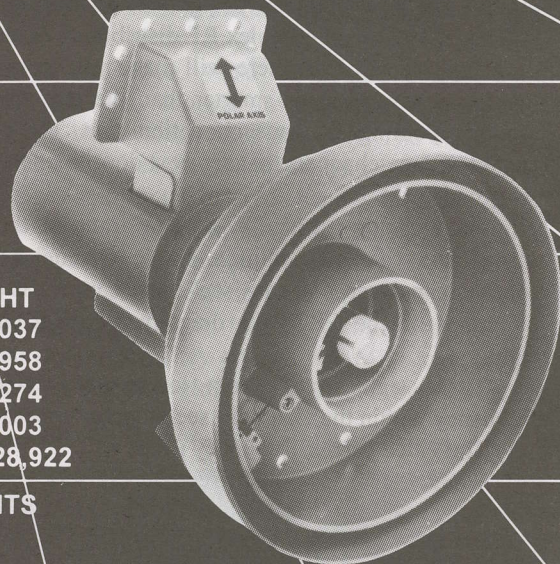

RPI-CKU Feed

**C AND KU CO-BORSIGHT
U.S. PATENT NO. 4,903,037
U.S. PATENT NO. 5,066,958
U.S. PATENT NO. 5,107,274
U.S. PATENT NO. 5,255,003
CANADA PATENT NO. 1,328,922**

**U.S. & FOREIGN PATENTS
PENDING**

ADL HYBRID MODING CIRCULAR POLARIZED INTELSAT FEEDS WITH EXCLUSIVE T.I. REJECTION



RP1-CP400



CP-300



CPOR-100

- C BAND LINEAR & CIRCULAR • C/KU LINEAR & CIRCULAR • KU 12 GHz FEEDS
 - INTELSAT 4 GHz CIRCULAR • ARABSAT S BAND FEEDS
- OPTIONAL: CO-BORSIGHT S BAND

2216 AGATE COURT, UNIT B, SIMI VALLEY, CALIFORNIA 93065 • (805) 526-5249 • FAX (805) 584-0634

NEW ADL Web site - www.adlfeed.com

The World of RF Distribution

(part one)

There is a myth - a misconception - that it is not practical to operate television service on *immediately adjacent* channels. What this means is that if you are in Australia, and you have a TV station operating on channel 7 (visual carrier frequency of 182.25), it is not practical to utilise either channel 6 (visual carrier frequency of 175.25) nor channel 8 (Vcf of 189.25). This is total and utter hogwash and we will explain why here. And when we are finished, you should have an entirely new outlook on how you can design, install and operate motel, hotel, and apartment complex RF distribution systems.

What you will learn here will make you money - and also make you several steps smarter than the guy who is running around spouting the misconception that TV programming cannot occupy channels that are next door to one another.

As broadcast-

Analogue terrestrial TV stations transmit three separate, identifiable carriers within a single channel (1). With a spectrum analyser, you can "see" these carriers as distinct blips or humps on the CRT. We diagram a typical channel upper right.

These signals are (from lowest frequency to highest frequency within the channel - see diagram upper right):

- 1) The video carrier frequency (Vcf)
- 2) The colour (sub) carrier frequency (Cscf)
- 3) The aural carrier frequency (Acf)

The Vcf in a Pal B channel plan is +1.25 MHz (megahertz) above the lower channel edge; for example, in the 7 MHz wide 174 - 181 MHz channel (channel 6 in Australia, channel 4 in New Zealand) the Vcf falls at 175.25. The Cscf falls another 4.43 MHz above the Vcf, or at 179.68 MHz. And the aural carrier is 5.5 MHz above the video at 180.75 MHz. This

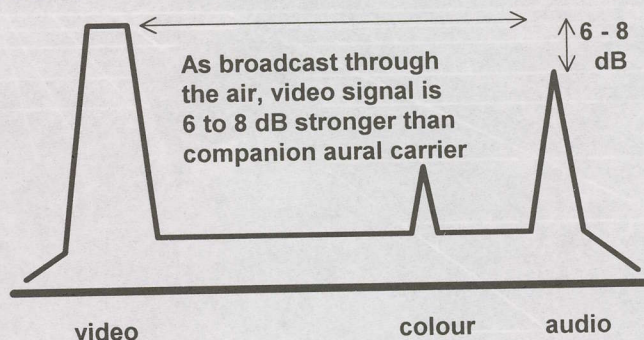

The "secret" - which isn't really a secret. Turn down the off-air aural carrier level (depicted above) so it is minus (-) 15 to 17 dB reference the vision carrier (depicted below), and, 99.9% of the TV sets can instantly handle adjacent channels - provided channel to channel levels are balanced (see text).

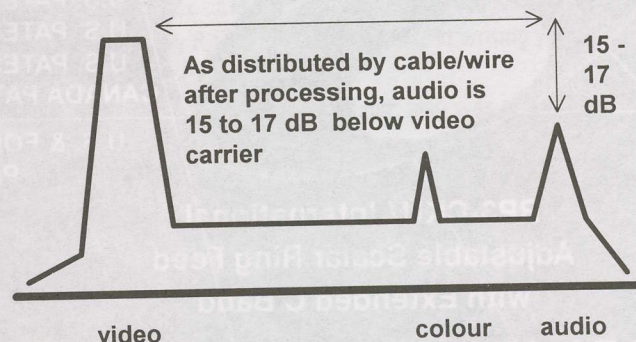

| | | | | | | | | | | | | | | |
|----------|--------|--------|--------|--------|--------|--------|--------|--------|--------|--------------------|--------|--------|--|--|
| NZ TV | 45.25 | 55.25 | 62.25 | | | | | | | | | | | |
| Ausr TV | 46.25 | 57.25 | 64.25 | | | 86.25 | 95.25 | 102.25 | | | | | | |
| Cable TV | 48.25 | 55.25 | 62.25 | 69.25 | 76.25 | 83.25 | 90.25 | 97.25 | 105.25 | 112.25 | 119.25 | 126.25 | | |
| NZ TV | | | | | | 175.25 | 182.25 | 189.25 | 196.25 | 203.25 | 210.25 | | | |
| Aust TV | | 138.25 | | | | 175.25 | 182.25 | 189.25 | 196.25 | | 209.25 | | | |
| Cable TV | 133.25 | 140.25 | 147.25 | 154.25 | 161.25 | 168.25 | 175.25 | 182.25 | 189.25 | 196.25 | 203.25 | 210.25 | | |
| NZ TV | 217.25 | 224.25 | | | | | | | | | | | | |
| Aust TV | 216.25 | | | | | | | | | | | | | |
| Cable TV | 217.25 | 224.25 | 231.25 | 238.25 | 245.25 | 252.25 | 259.25 | 266.25 | 273.25 | 280.25 | 287.25 | 294.25 | | |
| Cable TV | 303.25 | 311.25 | 319.25 | 327.25 | 335.25 | 343.25 | 351.25 | 359.25 | 367.25 | 8 MHz steps to 543 | | | | |

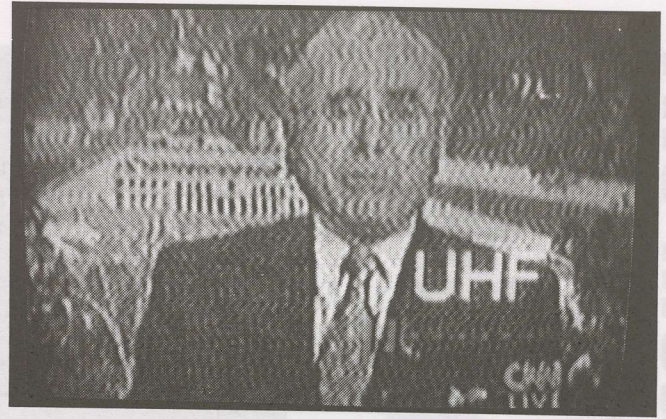
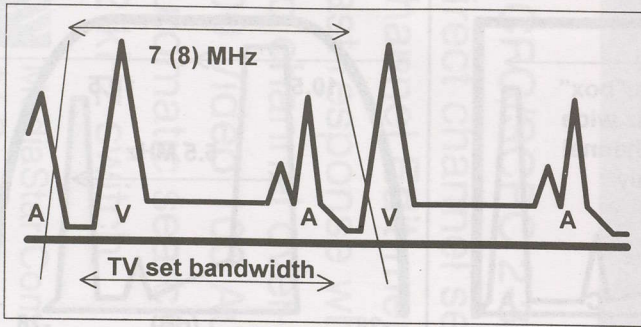

In processing the tuned-to-channel, the TV set must reject the lower channel (one below tuned-to-channel) aural carrier. If aural carrier is too strong, it puts herringbone/worms on video of tuned-to channel.

"channel plan" is uniformly followed through at least 230 MHz.

When the separate video and aural carriers, each modulated by their respective inputs, are combined for broadcast through the TV station's transmitting antenna, an adjustment is made between the Vcf and Acf carrier levels. Typically, the aural carrier is transmitted from 6 to 8 dB lower in power level than the Vcf. Why?

Bandwidth. The TV information occupies approximately 5 MHz of the channel while the aural carrier and its information occupies less than 1/4 MHz. At the receiving end, the TV set requires less Acf power to create clean audio than the wider bandwidth video. So the broadcaster, quick to save a penny, simply reduces the aural carrier power and attempts to balance

the two so that when the received signal level for the video is so weak as to produce a noisy picture, the sound is just starting to get noisy as well. If the aural was operated at the same power level as the video, you'd be getting perfect audio reception long after the video was unwatchable.

At the TV set, bandwidth comes into play. The tuner in the TV selects the desired channel, and the set's IF (intermediate frequency) stages amplify the desired channel. If you are trying to receive a weak signal level transmission on 189.25 (Australian 8, NZ 6) in the presence of a strong signal from 182.25, the TV set's IF "selectivity" causes the stronger aural carrier from 182.25's Acf at 187.75 to interfere with the weaker video at 189.25. They are but 1.5 MHz separated in frequency and this is too close together for the TV set to

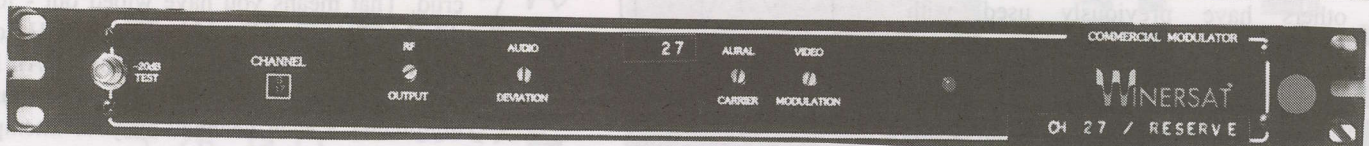

A "modulator" is a signal generator - low power transmitter - just like the big boys use, only at greatly reduced power. Virtually every VCR, satellite receiver has a built-in modulator. The "pro" models are "VSB" or "vestigial sideband" - which means a portion of the video transmission created by the modulator is "cut off" or "dumped" at the transmitter - the "lower sideband" portion is **not** broadcast, in the interest of spectrum efficiency, because the alternative - a double side band modulator - is redundant (see text).

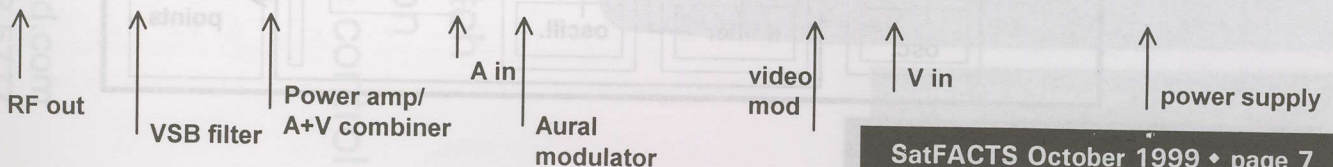
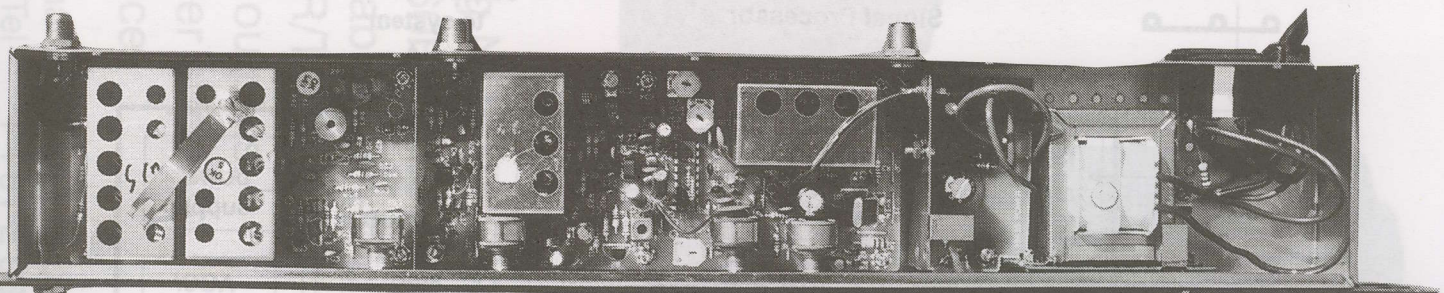

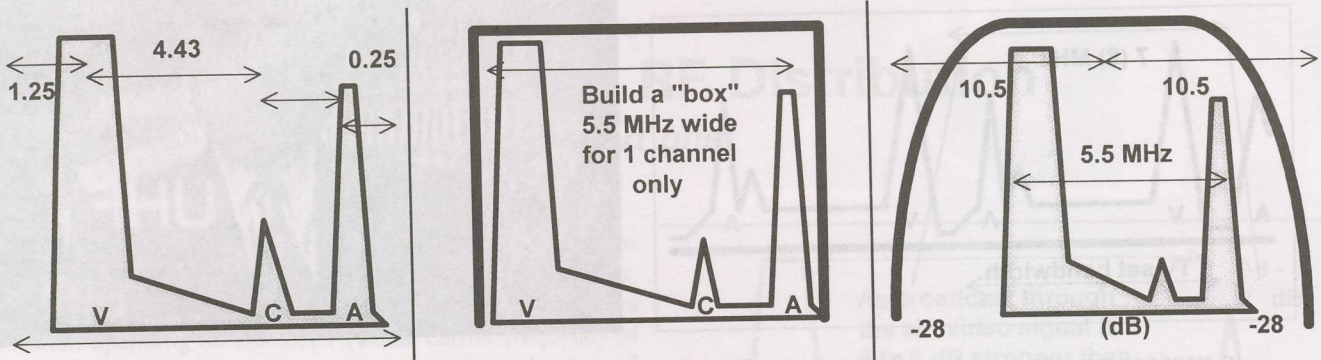

PAL "B" channel (48.25 through 294.25 - see table p. 11) is 7 MHz wide. Video carrier is +1.25 MHz up from lower channel edge, colour is +4.43 above video and aural is 0.25 MHz down from upper channel edge.

distinguish them. And thus the misconception that operating two TV channels on adjacent channels is a mistake. The problem, it turns out, is not that the TV set cannot separate the two but rather that the signal occupying 181-188 is far stronger than the signal occupying 188-195. When the audio from a "lower adjacent channel" is so strong as to interfere with the next channel up, you see interference (herringbone lines in the video) as is shown at the top right of p. 7.

MATV/SMATV equipment-

When designing an off-air terrestrial TV system, you work with what you have on hand and with the equipment others have previously used with success. The most common way to process from aerial to cable distribution off-air terrestrial channels is to install something called a "single channel (strip) amplifier."

The key words here are "single channel." If a PAL B format TV channel is 7 MHz wide, how "wide" (in bandwidth) then should a "single channel amplifier" be? The correct answer is 7 MHz - the same width as the TV channel. Unfortunately, products such as the widely used (Hills) Modulink (tm) Plus which are promoted as "single

channel" are in fact considerably "wider" than the 7 MHz channel. What that means is that a 181-188 MHz "single channel" amplifier actually covers (with varying degrees of performance) a frequency range of 174 to 195 MHz. If you have two "single channel" amplifiers processing (Australian) "7" and "9", their combined bandwidth of 174-209 MHz is as big as a barn door!

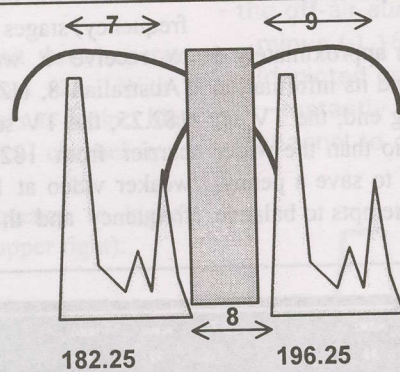

Now, suppose you are processing these two channels through a MATV/SMATV system. Between 174 and 209 MHz (plus typically several more megahertz below 174 and above 209), you are transmitting "garbage" through the MATV system - noise from the pickup aerials, amplifier noise, crud. That means you have wiped out - for that MATV system - more than 35 MHz of spectrum. 35 MHz? Well, if a single PAL B format signal is 7 MHz, you've just eliminated 5 such channels in your attempt to process two channels. And you will have a difficult - probably impossible - time using the 174-181, 188-195 and 202-209 MHz "spectrum" inside of that MATV/SMATV system as a result.

A more professional approach-

First, a single channel needs to be truly "single channel." Therefore when processing that single channel, you should not be building in bandwidth that wipes out other

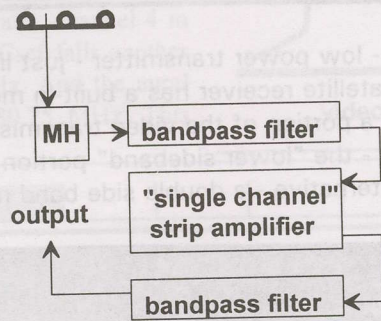

Frequency Agile Heterodyne Signal Processor

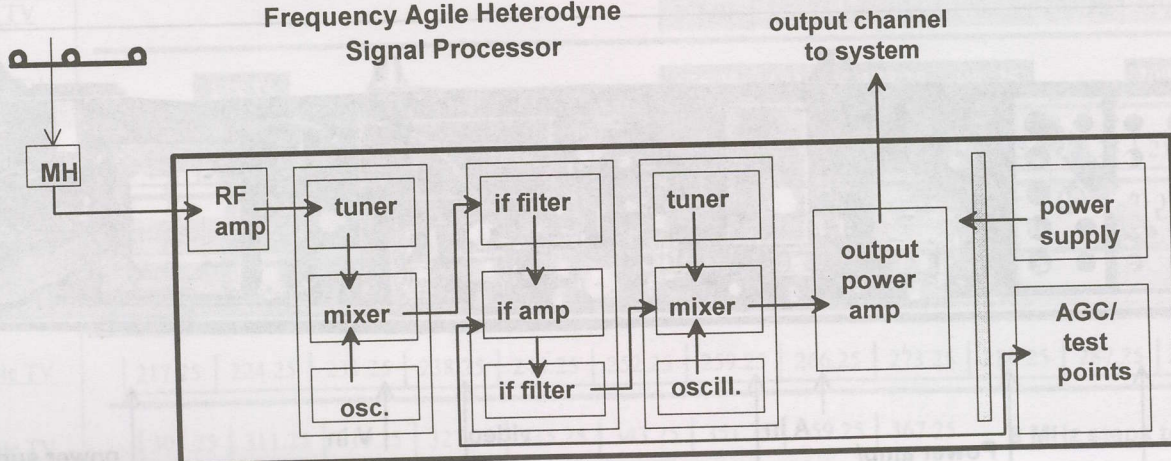

The Most Advanced Free To Air Digital Satellite Receiver

D7-MediaStar

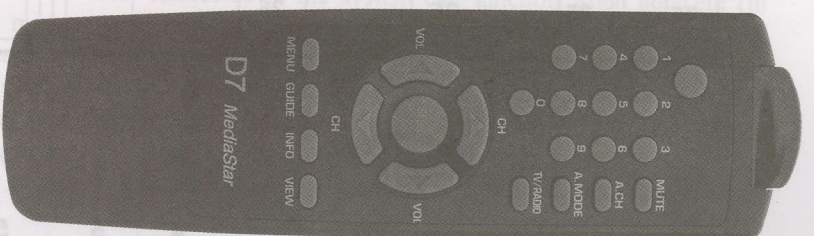
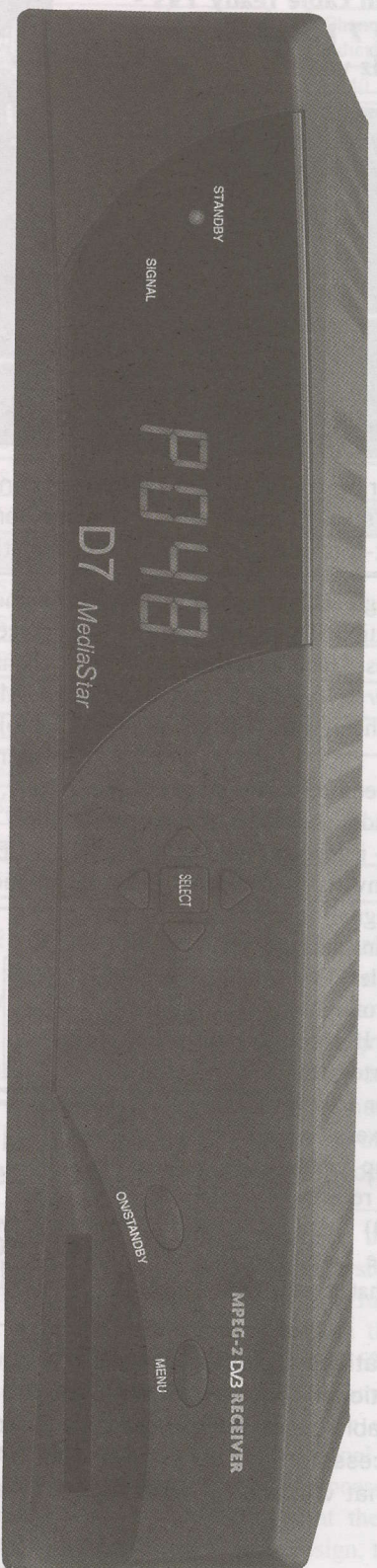

- MCPC/SCPC 2-36 Msym
- Direct channel selection from channel list
- Channel Edit menu Delete, Skip, ON.
- Fast response when changing channels
- No channel over-write
- 200 Video 100 Audio channels
- Automatic search and download
- 22 KHz switch
- PID Menu
- NTSC/PAL Auto switching NO NTSC Glitch
- NTSC converted to PAL-60Hz Free Option
- Audio L, R, Stereo selectable via remote control
- RF Modulator PAL-G, VCR/TV Scarts, RCA Audio/Video, SVHS outputs.
- 90-265VAC-50-60Hz power supply
- Low threshold performance



MediaStar Communications International
24 Bosci Road
Ingleburn NSW 2565 Australia

E-mail opac@bigpond.com
Tel ++61 2 9618 5777
Fax ++61 2 9618 5077

To match TV set tuners in cable ready TVs -
40-300 MHz channels are 7 MHz wide, above
300 - 8 MHz wide

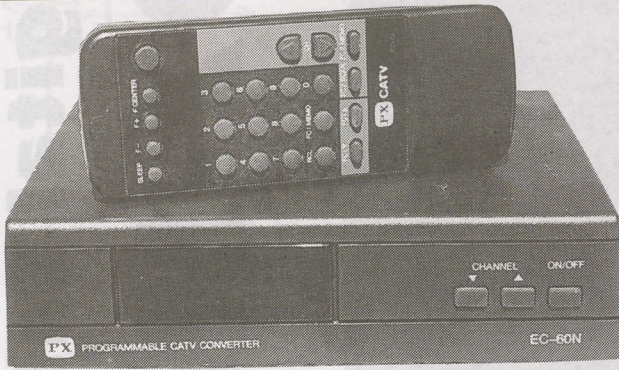

When you find yourself requiring more TV-set-channels than are available in your wired facility, there are two choices: Replace the TVs with "cable ready" (hyper-band tuning) TVs, or, equip each TV set with a frequency-extending "set-top-unit" (converter - above) that tunes the spectrum from 48 to 550 MHz.

channels in the process. A single channel amplifier is an obvious low-grade technical solution if you are interested in preserving spectrum for other uses - such as adding a satellite fed modulator. The answer is *throw out* the so-called single channel amplifiers and replace them with heterodyne signal processors. How's that?

We have to do something to ensure that a single channel stays inside of its 7 MHz bandwidth. A heterodyne processor does this by acting like a TV set - it receives the input channel (such as 181-188) and down converts that channel to an IF range (see p. 8). There the signal is amplified, and in the process the installer can adjust the aural (Acf) carrier level as it reappears at the output of the heterodyne processor. After the IF, the processed channel is upconverted to either the same channel again or to an entirely new channel. For example, because the processor has dial-up input and output frequencies, you can receive 208-215 (Australian channel 10) and after processing send it into the cable system on 209-216 MHz. What that

immediately does is correct the bureaucratic oversight that placed (Australian) TV channel 9 at 195-202 and Australian channel 10 at 208-215 MHz - leaving not 7 MHz but a skinny 6 MHz "opening" between 9 and 10. A single channel amplifier cannot "move" (shift) channel 10 up by one MHz - a heterodyne processor can. In the process, you gain one brand new, MATV distribution 7 MHz wide channel which you can now use for a satellite service fed modulator.

But of course heterodyne signal processors cost lots of money - right? Well, the Hills Modulink (tm) Plus list for one

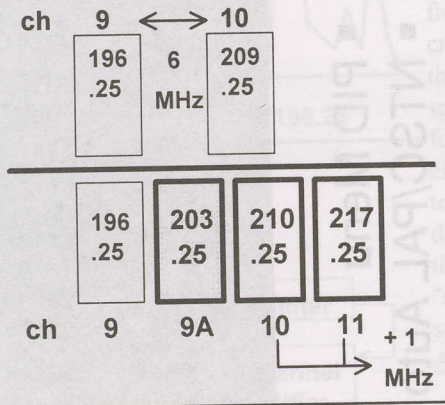

"single channel amplifier" is A\$653. A Winersat model WAP-600N/600SL heterodyne processor is A\$456. Yes, the heterodyne unit that cleans up the wide bandwidth of "single channel amps" actually costs less than the 1960 era device and works on any input or output channel. And if you are in love with "single channel amplifiers" - the Winersat WCA-400 is A\$94.

Clean and balanced-

Once you have "cleaned up" the MATV/SMATV spectrum by tossing out

When the TV channel allocations table has been screwed up by bureaucrats acting on political instructions, how do you "squeeze" additional channels into the spectrum such that "standard" TV sets can pick them up without the addition of a (cable type) set-top-converter? You can "gain" 2A and 2B as shown below, and by using heterodyne signal processors for 7, 9 and 10 add "9A" as shown above. Now you have 16 channels to "play with" that virtually all (Australian) TV sets can tune - without a converter.

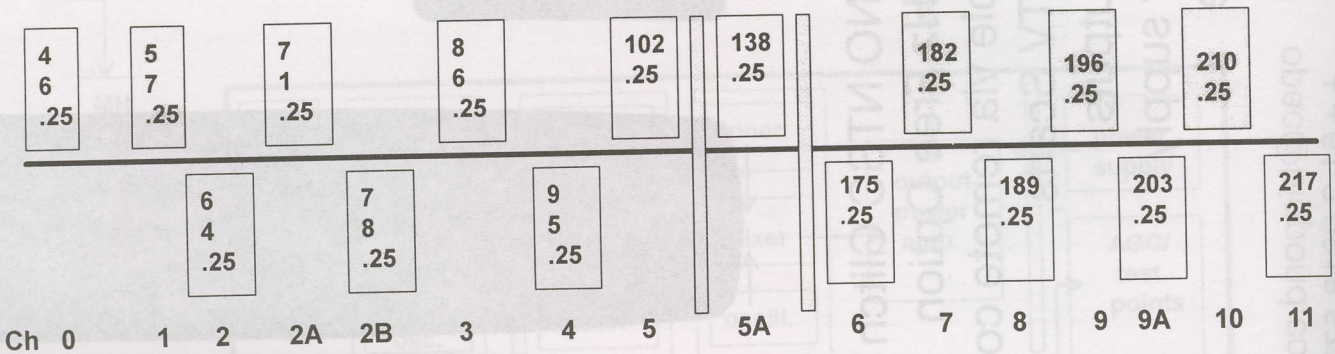

| Channel Indicator | Channel # | Video (MHz) | Audio (MHz) |
|-------------------|-----------|-------------|-------------|
| 2 | E2 | 48.25 | 53.75 |
| 3 | E3 | 55.25 | 60.75 |
| 4 | E4 | 62.25 | 67.75 |
| 93 | X | 69.25 | 74.75 |
| 94 | Y | 76.25 | 81.75 |
| 95 | Z | 83.25 | 88.75 |
| 96 | Z + 1 | 90.25 | 95.75 |
| 97 | Z + 2 | 97.25 | 102.75 |
| 98 | S1 | 105.25 | 110.75 |
| 99 | S2 | 112.25 | 117.75 |
| 13 | S3 | 119.25 | 124.75 |
| 14 | S4 | 126.25 | 131.75 |
| 15 | S5 | 133.25 | 138.75 |
| 16 | S6 | 140.25 | 145.75 |
| 17 | S7 | 147.25 | 152.75 |
| 18 | S8 | 154.25 | 159.75 |
| 19 | S9 | 161.25 | 166.75 |
| 20 | S10 | 168.25 | 173.25 |
| 5 | E5 | 175.25 | 180.75 |
| 6 | E6 | 182.25 | 187.75 |
| 7 | E7 | 189.25 | 194.75 |
| 8 | E8 | 196.25 | 201.75 |
| 9 | E9 | 203.25 | 208.75 |

| Channel Indicator | Channel # | Video (MHz) | Audio (MHz) |
|-------------------|-----------|-------------|-------------|
| 10 | E10 | 210.25 | 215.75 |
| 11 | E11 | 217.25 | 222.75 |
| 12 | E12 | 224.25 | 229.75 |
| 21 | S11 | 231.25 | 236.75 |
| 22 | S12 | 238.25 | 243.75 |
| 23 | S13 | 245.25 | 250.75 |
| 24 | S14 | 252.25 | 257.75 |
| 25 | S15 | 259.25 | 264.75 |
| 26 | S16 | 266.25 | 271.75 |
| 27 | S17 | 273.25 | 278.75 |
| 28 | S18 | 280.25 | 285.75 |
| 29 | S19 | 287.25 | 292.75 |
| 30 | S20 | 294.25 | 299.75 |
| 31 | S21 | 303.25 | 308.75 |
| 32 | S22 | 311.25 | 316.75 |
| 33 | S23 | 319.25 | 324.75 |
| 34 | S24 | 327.25 | 332.75 |
| 35 | S25 | 335.25 | 340.75 |
| 36 | S26 | 343.25 | 348.75 |
| 37 | S27 | 351.25 | 356.75 |
| 38 | S28 | 359.25 | 364.75 |
| 39 | S29 | 367.25 | 372.75 |

| Channel Indicator | Channel # | Video (MHz) | Audio (MHz) |
|-------------------|-----------|-------------|-------------|
| 40 | S30 | 375.25 | 380.75 |
| 41 | S31 | 383.25 | 388.75 |
| 42 | S32 | 391.25 | 396.75 |
| 43 | S33 | 399.25 | 404.75 |
| 44 | S34 | 407.25 | 412.75 |
| 45 | S35 | 415.25 | 420.75 |
| 46 | S36 | 423.25 | 428.75 |
| 47 | S37 | 431.25 | 436.75 |
| 48 | S38 | 439.25 | 444.75 |
| 49 | S39 | 447.25 | 452.75 |
| 50 | S40 | 455.25 | 460.75 |
| 51 | S41 | 463.25 | 468.75 |
| 52 | 21 | 471.25 | 476.75 |
| 53 | 22 | 479.25 | 484.75 |
| 54 | 23 | 487.25 | 492.75 |
| 55 | 24 | 495.25 | 500.75 |
| 56 | 25 | 503.25 | 508.75 |
| 57 | 26 | 511.25 | 516.75 |
| 58 | 27 | 519.25 | 524.75 |
| 59 | 28 | 527.25 | 532.75 |
| 60 | 29 | 535.25 | 540.75 |
| 61 | 30 | 543.25 | 548.75 |

Explanatory notes: Channels E2-E4, E5-E12, 21-30 can be tuned in by virtually any (PAL format) TV set. Channels X - Z + 2, S6-S10 can be tuned in by 90% of all (PAL format) TV sets. Channels S1-S5 are often left out (108-138 MHz) of non-cable-ready TV sets. Some (Sony in particular) will tune E2-Z + 2, S6-E12 and S21-30 missing S1-S5 and S11-S20. Modulators are sold and designated by second column ("Channel #") frequency listing. Note channel spacing changes from 7 MHz to 8 MHz at S21; the channels between S21 and S41 are known as "CATV Hyperband." Also note channel # designations change to European terrestrial channel numbers at 471.25 (as simply "21"), not to be confused with S21 appearing earlier! First column each row ("Channel Indicator") means cable set-top-box channel number.

"dirty" single channel amplifiers, the next step is to make your secure-in-cable spectrum mesh with the capability of the TV sets it will serve. *Observation:* Every TV set manufacturer seems to have his own technical rules for determining what spectrum the tuner in the set will actually tune-in. The Australian spectrum is one of the most "kludged" (look it up) in the world. This was done on purpose by political bureaucrats to try to preserve an Australian TV set manufacturing industry; create channel assignments no other country in the world utilises, they reasoned, to discourage those nasty guys in Asia from producing TV sets for the Australian market. Modern day varactor/IC controlled TV tuners have pretty much solved that one but for a couple of decades it worked.

As we show on page 10 (bottom), with some minor rearranging of a few channels here and there, you can create a 16 channel "TV spectrum" within a MATV or SMATV system which virtually all Australian TV sets can tune. That's at least 3 more than frequency planning bureaucrats originally intended - and with some luck, 16 could just as easily be 20 channels. We'll explain.

Remember the 6-8 dB difference in power level between the Acf and the Vcf created by the broadcaster? Well, that ratio is

fine for off-air reception but totally unnecessary for a cable (MATV) distribution system. A TV set that receives an appropriate (such as 80 dBuV) signal level on the Vcf does not need 72 to 74 dBuV on the Acf to produce quality sound. What it needs is around 63 dBuV - or, 17 dB less Acf than Vcf. What you need is some method to turn *down* the Acf, to balance the aural power versus the video power on each channel. A "single channel amplifier" offers no such control. Yes - the heterodyne processor does. With a signal level meter, you set up the Vcf at the level called for by the MATV distribution system design, then you tune-in the Acf and using a front panel adjustment set it 17 dB lower in level.

Why? Because this is your *key step* in making sure the TV sets connected to the system can function when adjacent (in frequency/channel) spectrum is used within the system. By turning the Acf down to -17 dB relative the Vcf, the TV set still produces fine audio - but when it is tuned to 181-188, the sound carrier from 174-181 (located at 180.75 MHz) no longer "crawls" into the video image centred on 182.25 MHz. This is the "secret" to how cable TV systems can stack one channel after another through the full spectrum from 54 to 550 MHz

(or higher) and not have "wormy pictures."

Now - what about modulators? Here the requirements are similar. A "real" TV station has a special type of modulator called Vestigial Sideband (VSB). What that means is the modulator occupies only a 7 MHz (PAL B format) bandwidth by eliminating redundant (duplicative) information. A TV modulator has a video carrier frequency and "modulation sidebands." There is a "lower" sideband and an "upper" sideband. It turns out the TV set only requires *one* of these to reproduce an image. And since a "double sideband" modulator (using both upper *and* lower) takes up nearly twice the spectrum as a VSB version, the transmitter eliminates one of these sidebands as unnecessary before transmitting through the air.

It costs more money to build a VSB modulator. The world is filled with DSB (double sideband) modulators - every VCR has one, video games use DSB, your satellite receivers as well. A DSB modulator operating on 181-188 MHz wipes out 175 -188 - at least. That extra (lower) sideband effectively ruins for alternate use the channel that is immediately below the operating channel.

So if VSB modulators cost more (eliminating the unwanted sideband is tedious) then we can expect MATV/SMATV modulators of the VSB family to cost more than the DSB units?

Maybe it is *where* you buy the DSB units - one brand "H" AVM1 version lists for A\$704. A Winersat WCM300 sells for A\$106. Both are single channel modulators but the AVM1 chews up two channels while the WCM300 is clean and can be used on adjacent channels. The AVM1 has a maximum output of +80 dBuV, the WCM300 is +115 dBuV. The WCM300 allows you adjust the output carrier level, set the aural carrier level (-17 dB from video is recommended for adjacent channel operation), adjust the video and aural modulation for best looking/sounding service. The AVM1 does none of the above.

Now - for the record, this report is neither a whack at Hills nor a promotion for Winersat. Both are cited as *examples* of your options - you can create a "dirty" MATV/SMATV spectrum with "single channel amps" and "double sideband modulators" or you can stack up 16 or more TV channels for present or future use confident that what you are installing today will not reduce your options tomorrow. There are more

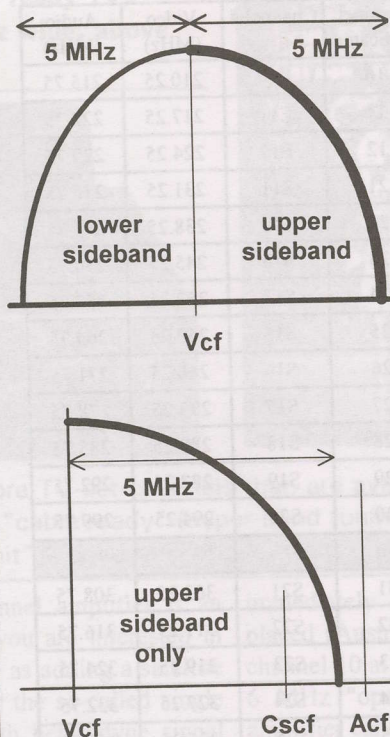

options - an agile modulator that allows you to dial up any frequency between 40 and 550 MHz - ideal for those installations where as DVB-T comes on line you may need to do channel rearrangements. Agile modulators? A\$311.

DVB-T ...

DVB-T stands for "digital video broadcasting - terrestrial." It is the FTA broadcast TV equivalent of the European bouquet and tests are already functioning (on [Australian] channel 8 - 188 - 195 MHz) in Sydney. Flip back now and look at the drawing in the middle of page 8. There is channel 7 (181-188) and channel 9 (195 - 202) and squarely between them is previously unused channel 8.

Sometime in 2001, commercial DVB-T launches in the major Australian cities. The channels in use will virtually always be those that are immediately adjacent to the existing analogue channels ("7" to 6-digital, "9" to 8 digital) and so on. A digital signal, operating on an immediately adjacent channel, will flow through existing single channel amps in a

degraded form. A "7" single channel amp will process channel 6 but very badly - because of the roll-off (reduced gain) of the "7" amplifier the further one goes away from "7." Moreover, the extra signal "power" from the new digital services (on 6, 8, 11) will create signal overload problems for those who are operating existing single channel strip amplifier distribution systems at "full gain" (50 + dB).

DVB-T testing has not included analysis of what the COFDM (modulation format) DVB-T signals will do to existing MATV systems. The answer, expected, is the digital signals will:

- 1) Not be usable through the existing analogue "single channel amplifiers," and
- 2) Are likely in many cases to cause significant signal degradation for the present analogue signals being processed.

This tells us that from this date forward, any use of "single channel amplifiers" must be carefully weighed against the future use of adjacent channels for digital broadcasting, and/or the need to create special service channels inside of an MATV/SMATV environment for carriage of satellite or other video services. We'll explore that further next month.

- 1/ The aural carrier frequency (Acf) can usually be isolated and identified on a signal level / field strength meter. The colour subcarrier frequency (Cscf) can only be identified on a spectrum analyser.

small, medium and LARGE C and Ku antennas in stock!

Transmit and receive antennas from 1.2m to 13m (Intelsat Standard B). Linear and circular feeds (AsiaSat, Palapa, JcSat, Rimsat, PanAmSat, Intelsat and more) for transmit and receive-only applications. Receive and transmit electronics including inclined orbit tracking equipment with motor drives for elevation and azimuth to 50 tons. Complete system design, fabrication, installation + proof of performance.

P
A
C
I
F
I
C



A
N
T
E
N
N
A
S

Limited

Pacific Antennas Limited

Bryon G.G. Evans, PO Box 265, Whangaparaoa.NZ
Tel/fax 64-9-424-0841 • Mobile 025-789-160

ON September 21st at 0900UTC
<http://www.satfacts.kwikkopy.co.nz>
posted a news report.

MADMAX jailed in Bangkok (September 21): The South African based Irdeto card piracy operator, known through Internet as MadMax, has been arrested in Bangkok, Thailand where he faces several years in a Thai jail. According to reports supplied to us by Mindport Solutions Australia, and other sources, MadMax flew from Cape Town to Thailand September 13. He was apprehended in Thailand with equipment designed to videotape the Thai (UBC et al) Irdeto protected pay-TV platform. Mindport tells us, "this was (to be) similar to what he did in Australia (earlier this year)." By recording encrypted Irdeto transmissions, apparently MadMax and his colleagues would then be able to analyse the taped materials to create MOSC cards for the Thailand market. He was arrested on Tuesday September 14th with equipment, and on Thursday September 16th a Thai judge refused him bail. On or before September 29 attorneys for Madmax are scheduled to lodge an appeal and if they fail, MadMax is expected to "be in jail in Thailand for a few years."

DURING the next 3 hours our average hourly log-in rose **28.2%**.

OVER the next 24 hours, it rose **222.1%**.

IN the first 52 hours of posting this item, we measured a cumulative rise of **39.8%**.

SatFACTS DAILY - the Web site -

is read, checked *and believed* by more members of the Pacific - Asia TVRO industry family than any other news oriented Web site in the world!

Which makes <http://www.satfacts.kwikkopy.co.nz> the most attractive advertising medium for selling, locating or trading equipment, personnel, or information in the Pacific - Asia satellite world!

Advertising rates - as low as A/NZ/US\$40 for seven days of PAGE ONE display space, and on page two - our "classified section - NON-COMMERCIAL (individual sale or purchase) listings" are without charge - *for two weeks*. And even lower per-week rates for month-long displays. PLUS - you can change the content *daily* if you wish - to reflect your changing in-stock or equipment-required status!

And discounted package prices - when you advertise on www.satfacts.kwikkopy.co.nz PLUS in SatFACTS Monthly Magazine PLUS on SPACE Pacific Report - *the TV show!* To reach the mushrooming Pacific - Asia professional satellite dealer at his place of work, we have the answer!

Bottom line?

SatFACTS reaches more installing dealers, repair shops, satellite professionals than all other news and information mediums *combined*.

If you have products or services for this rapidly growing marketplace, *talk to us*. We have the contacts and the delivery system to get your message delivered!

Talk with Bob Cooper at 64-9-406-0651, fax at 64-9-406-1083, e-mail at Skyking@clear.net.nz.

This guy ain't no Robin Hood-

MadMax lands in Thailand Jail - Mindport/Irdeto claims credit

MadMax (alias Madmax, alias Rolf Deubel) was reported to have been arrested and arraigned before a judge in Bangkok, Thailand on September 16 - three days after flying from Cape Town. Mindport (parent of encryption technology Irdeto) advised:

"Over the past few months we have been working with a number of organisations monitoring Madmax and his affiliates. This (activity) culminated after he flew from his home in Cape Town (to Bangkok) to record the UBC transmissions - similar to what he did in Australia mid year. He was caught red handed with his equipment. The judge refused bail and put Madmax into a Thai jail - not a nice place to be. There will probably be an appeal and if unsuccessful Madmax will be in jail (in Thailand) for a few years."

MadMax had turned the Australian smart card pay-TV world upside down. As recently as late August, his technology to modify pre-existing ex-Galaxy or Austar or Foxtel smart cards to operate without payment of a subscription fee to the programmer seemed to be winning a war with the programmers. He was a grey ghost in the night, using Internet and a few close associates to create havoc. In late July, the pay-TV programmers descended on Canberra and lobbied Government ministers and elected members of Parliament asking for urgent, new legislation to clearly define that tampering with pay-TV authorisation systems, dealing in modified smart cards, or providing information to others leading to avoidance of paying for pay-TV would be a criminal offence.

But MadMax was on a roll and hundreds - perhaps thousands - of Australians found his Internet sites and sent off money and non-functioning smart cards to an address in Cape Town (Promotec, 1 Broad Road, Milnerton) which he explained, "(Promotec) is NOT my firm but a good friends which we use for business. This company is used only as a relay address. Promotec themselves do nothing but nothing illegal at all. They do distribute SSDs which is absolutely legal to do in South Africa!" Something temporarily spooked MadMax in mid-July, and he notified, "We are moving the

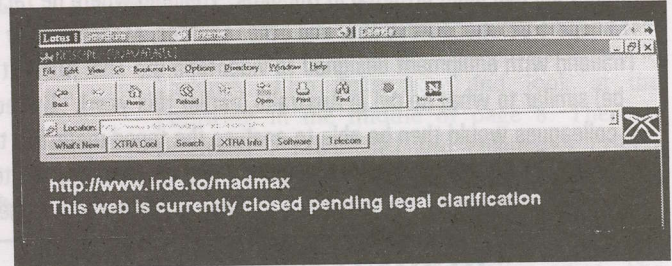

TOO clever for words: Madmax's Australian site
<http://www.lrdeto.com/madmax/aus>
was closed down by Internet Service Provider

MOSC/SSD operation out of this country, to one where what we do is not a problem - if you know what I mean!" For a brief period, e-mails from him were captioned in German and his return address was given as madmax@thoic.com - a site that would figure prominently in his activities by August.

His "midyear" visit to Australia, referenced by Mindport, bordered on disaster. First he linked with a Melbourne firm that was rumoured to have been active supplying MMDS and cable piracy equipment; that would be L&M. Even before he left the country, a Web site was advertising MOSC cards and SSD (Smartcard Slot Doubler) equipment through L&M. Within 24 hours, the advertising disappeared from the Web, and MadMax

now back in South Africa, issued an apology stating, "We made a mistake by putting L&M's contact details onto the website without them knowing." Indeed. Within a week, L&M had taken down all signs, turned off their phones, and seemingly disappeared from the face of the earth. Running scared was becoming contagious.

Most of the discussion about MadMax found on Internet assumes the biggest danger facing the man and his operation were legal responses from the authorities. He did not share that concern - yes, law and order was a threat. But there were worse things that could happen to him.

He wrote, "My friend Tron died under very suspicious circumstances." Tron was a gifted computer whiz, said to be

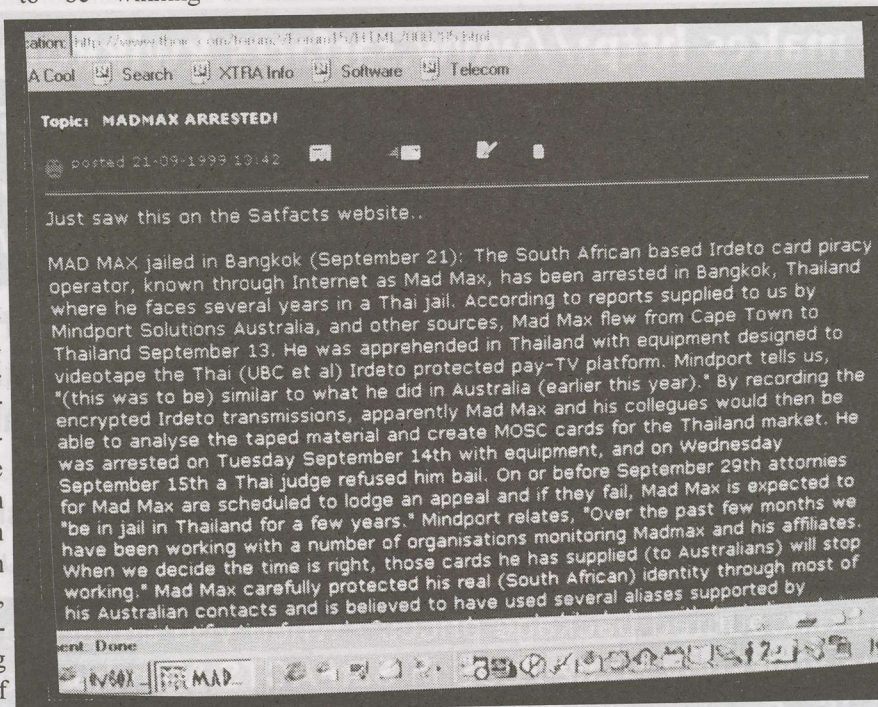

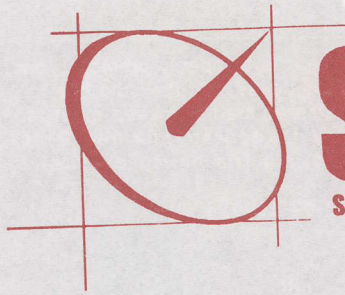

SATECH

Satellite Communication Technology Pty. Ltd.

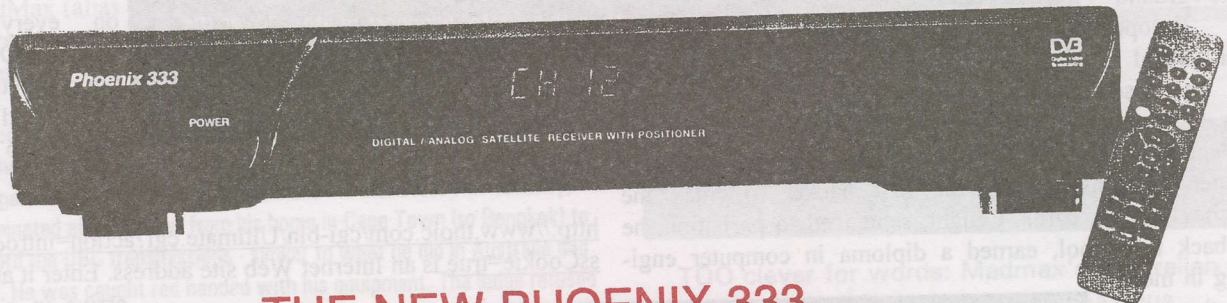

THE NEW PHOENIX 333 with new software

Phoenix 333 - as quoted in November issue of SatFACTS " If we were forced to make a decision between owing any digital and any analogue receiver we would decide on owing the Phoenix 333"

- 3 in 1 Digital-Analogue-Positioner
- High Sensitivity on Digital
- Low Threshold on Analogue
- Heavy Duty Power Supply for Positioner



THE NEW PHOENIX 111 " REVOLUTIONARY IN COST AND PERFORMANCE "

Phoenix 111 - power supply and software specially designed for Australian conditions

- Digital
- High Sensitivity Loop through Tuner
- Built Digital NTSC to PAL Converter
- Heavy Duty Power Supply



Sole distributor for Phoenix Worldwide



SATECH

Satellite Communication Technology Pty. Ltd.

Head Office: 6/477 Warrigal Road Moorabbin East Victoria Australia 3189 Ph: 613 9553 3399 Fax: 613 9553 3393



SATECH Distributors for the full range of CALAMP

CABLES

Times Fibre & Comscope

huge range of RG6 & RG11

- dual
- quad
- flooded
- messengered

also 5 core tracking system cable
(available by reel or per meter)

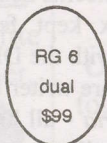

- CALAMP C band 25k voltage switching LNBF
- CALAMP KU band 1db prime focus voltage switching LNBF
- CALAMP KU band 1 db off-set voltage switching LNBF
- CALAMP C band digi-ready phase locked loop 25k LNB
- CALAMP C band mini-mag 17k LNB
- CALAMP C band mini-mag digi extended 20k LNB
- CALAMP KU band 0.8 db LNB
- CALAMP KU band 1db high stability LNB
- CALAMP C band extended professional II low phase 20k
- CALAMP MMDS integrated antenna

also available cyclone 2.3m mesh dish

- | | | |
|-----------------|----------|----------------|
| easy to install | reliable | cost effective |
|-----------------|----------|----------------|

CHECK OUT OUR WEB PAGE ON

www.satech.com.au or email to us at satellite@satech.com.au

One Stop Shop

- receivers
- dishes
- cables
- fly leads
- wallplates
- feedhorns
- Lnbs
- tools
- tape
- poles
- decktite

SATECH
Distributors
for the
full range of
PARACLIPSE

Ring us for the latest products from Strong Technologies

- Dishes 65 cm, 90 cm and 2 - 3 m
- LNB's
- Digital Receiver

DISHES

SATECH your no.1 paraclipse distributor for the complete paraclipse range

Paraclipse Dishes

- exceptional strength and wind resistance
- accurate reception

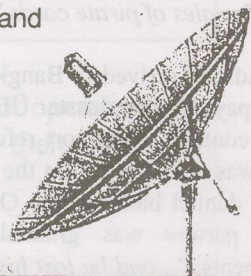
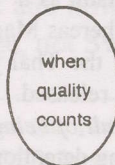

Paraclipse
HIGH PERFORMANCE ANTENNAS

All products available through the following SATECH distributors:

- Satech (Victoria) Tel: (03) 9553 3399
- South Satellite (South Australia) Tel: (08) 8377 0955
- Network Satellite Services (NSW) Tel: (02) 9687 9903
- Norsat (Western Australia) Tel: (08) 9451 8300
- Mathews Electronic Service Services (New Zealand) Tel: (09) 634 5130, outside Auckland 0800-777 376

(< continued from p. 15)

"Closed pending legal clarification."

Why Thailand?

On July 1, MadMax told SatFACTS, "*Yes we are the guys doing the smartcards and yes we are currently based in South Africa. We will move our HQ to a country where no IRDETO based Pay-TV can be purchased for legal reasons soon! Currently we are not only modifying Optus/Aurora smartcards but also 'old' Galaxy smartcards as well for the Foxtel/Austar platform. We also do Thai DTH Irdeto based smartcards and soon the new Hong Kong / China Irdeto based services. And yes ... you've guessed it, we also do all European and Middle East Irdeto based smartcards.*"

Thailand. The country has no laws specifically designed to inhibit card piracy, but unfortunately for MadMax it has a reputation for a "management style" which lends itself to persuasion. Mindport claims their influence on Thai authorities and as MadMax was apparently under surveillance from the moment he left his home in Cape Town through to his destination in Bangkok, Thailand would turn out to be a bad place to visit for the card shark. One Thai law buried deeply in the law books prohibits "*modification of radio receivers*" - a 5 year jail sentence is automatic - it is doubtful MadMax knew about this law before leaving Cape Town. Before he left on the trip, a number of exchanges occurred between him and a prominent contact in the UK.

"I was privileged to share much information with MM. The messages I have leading up to his venture in Thailand were dominated by his own concerns about a proposed meeting he was to have (in Thailand) with someone from the UK. MM was curious why this person insisted on meeting him at his hotel in Bangkok when he could have easily met him anytime in South Africa or even Europe! To cap the intrigue, after we had checked flight costs, this same person wanted to introduce his business partner to MM at the time of their meeting. MM was highly suspicious and copied me emails he received back from the UK contact whose content was bordering on insisting his partner attend."

The name of the person MM was concerned about is known to SF - we will not share it with you as we have been unable to encourage this person to respond to our queries. This individual is well known in Europe for "*his advertising and prolific sales of pirate cards.*"

MadMax arrived in Bangkok ready to record transmissions from pay-TV broadcaster UBC. He had a previously arranged local contact - Mindport refers to this person as a "partner" - who was also arrested in the bust. And whereas MadMax was twice denied bail through October 6 by the Thai judge, the Thai partner was granted bail and released. Mindport comments, "*...and he lost his job as a result of being involved in this activity.*" MadMax was facing a long detention, because as a Bangkok journalist reports, "*I am aware of people here who work at radio stations, who have been caught modifying equipment without permission, and who are arrested, held in jail for months with no formal charges brought, and then released. This wouldn't happen in a more Western country - it happens here all too often.*"

MadMax - The human being-

There are two distinct levels in the card piracy world - not counting the "consumers." Level one, the elite, are the guys and gals who bust the cards, the software writers. They are driven only by the challenge, and seldom get involved in the marketing of piracy products. An elitist tells SF,

"X (the individual who was pressing MadMax to meet him in Bangkok) *is commercial only.* He doesn't mix in the same circle of friends as me and we share no common interests. He is only motivated by money, I guess. I've since learned MM shared his concerns about this on a recent visit to Austria."

MadMax kept feet in both camps, clearly in direct competition with the DPSC folks (whom he feared), and also a skilled software writer in his own right. On August 2 he wrote, "*Am in Austria - all 'friends' are here for the wedding of our friend and colleague AlBundy.*" AlBundy is another card creator. Attending the wedding, "Snoopy, Sandokan, Cuba Libre, Dr Ice." The Austrian wedding was a closed affair, of course, but there were stories afterward. A UK source tells SatFACTS, "*MadMax shared his concerns about the insistence that (X) be allowed to bring his business partner to Bangkok to meet MM, with his friends in Austria.*"

Did Mindport have help in snagging MadMax? Only they know for sure - and are not saying. An elitist who knows MadMax "well enough" comments, "*While it appears that Mindport Australia have certainly done their homework, it may well have been the bumptious attitude MM had towards piracy and his openness with the media and net community that conspired to his downfall. I would have thought that he would have been better off to have maintained a low profile - I get the impression MM enjoyed the media attention.*"

(Bumptious? "Offensively self-assertive or conceited.")

"*He impressed me as so self-assured that he was dangerous to himself*" comments a European friend. "*He truly enjoyed living on the very edge, pushing the envelope. Moreover, not content with simply doing it - he wanted everyone to know he was doing whatever it was. I and others warned him constantly about his high profile, and that he was not being careful enough in his dealings.*"

The closure -

Thai authorities claim they know nothing about any of this - a perhaps not unusual scenario in a country where someone with resources can get the police force to act on their private behalf. Efforts by SatFACTS, through knowledgeable Thailand sources, to locate court records or even a story in the local press about the apprehension of MadMax and a "partner," have been non-productive. As the man says, "*this is a country where someone can be thrown in jail with no formal charges, held for several months and then released*" - without so much as a "thank you" or "sorry about that."

Mindport (Australia) is not so silent. This warning dated September 21: "*Sending money and cards for reprogramming is not a good investment at this stage, and when we decide the time is right, those cards he has programmed will stop working.*"

An update advisory dated October 5, says, "*Madmax, now in his third week of detention in a Thai jail, is singing like a bird to lighten the many charges against him. The Thai authorities have so far twice refused him bail. Madmax has provided us information on all contacts among the pirates as well as his customers. As the raid by the authorities in Belgium on Eurosat confirms, this is not a good time to have had any association with Madmax.*"

**TURN YOUR FIXED ANALOG OR DIGITAL SYSTEM INTO A
MULTI_SATELLITE SYSTEM WITH THESE ACCESSORIES:**

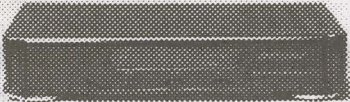
| | | |
|---------------------------------------------------------------------------------------------------------------------------------------------------------------------------------------------------------------------------------------------------------------------------------------------------------------------------------------------------------------------------------------------------------------------------------------------------------------------------------------------------------------------------------------------------|-----------------------------------------------------------------------------------------------------------------------------------------------------------------------------------------------------------------------------------------------------------------------------------------------------------------------------------------------------------------------|----------------------------------------------------------------------------------------------------------------------------------------------------------------------|
| <p><u>Single Axis Positioner</u> Update your fixed satellite system with this positioner.</p>  <p>Cat # M1000 \$199</p> | <p><u>18 inch Actuator</u> Special price \$260. Order M1000 and M1510 together and pay only \$400 SAVE \$60!</p> <p>Cat # M1510</p> | <p><u>24 inch Actuator</u> Special price \$280. Order M1000 and M1540 together and pay only \$420 SAVE \$60!</p> <p>Cat # M1540</p> |
| <p><u>0/12v Coaxial Relay</u> Automatically switch between 2 C band dishes or a C and K band dish. Suits IRDs with 0/12V RCA outlet. \$49</p> <p>Cat # P1700</p> | <p><u>Manual Coax Switch</u> Manually switch between 2 dishes and one receiver. This switch carries DC to the LNB and is rated to 2000MHz. \$39</p> <p>Cat # S2000</p> | |
| <p><u>Dual Band Combiner</u> Mix the outputs of 2 LNBs at the dish and feed one cable. Saves the extra cable run and drilling through walls etc. Use a standard IF splitter like our X1550 to feed 2 receivers inside. \$39</p> <p>Cat # X1750</p> | <p><u>4 Way A/V Signal Switcher</u> Too many remotes in your house? Use this intelligent switcher to prioritize A/V sources. Input 1 has priority. If source to Input 1 is off, Input 2 assumes priority. Detects and switches the active input to 2 parallel outputs. \$99</p> <p>Cat # T1951</p> | |
| <p><u>Satmaster Lite for Windows 95/98</u> Use this 2 disk software to give pointing co-ords for all visible satellites from your location, calculate down-link budgets for digital and analog signals, make solar outage predictions show rain attenuation etc etc. Has huge multicountry database. \$199</p> <p>Cat # S 1101</p> | <p><u>Logsat Professional</u> CD ROM software shows visual display of multiple satellites to allow prediction of exact location of inclined satellites at any time. Updated Keplerian elements are available every day via the Internet. We use this to find inclined Gorizont, amateur and polar orbiting satellites. \$119</p> <p>Cat # S1150</p> | |
| <p><u>The Practical Guide to Satellite TV</u> Second edition, printed this year has 122 pages of data, footprints, theory of operation and history of satellite TV. Find out how satellites work and how to receive their signals. Written in easy to understand language, not Swahili! \$39</p> <p>Cat # B1030</p> | | |
| <p>AV-COMM PTY LTD (ACN: 002 174 478) P.O. Box 225 Balgowlah NSW 2093 Australia TEL: 612 9949 7417 FAX: 612 9949 7095 Web: http://www.avcomm.com.au Email: sales@avcomm.com.au You are welcome to join our E-Mail Newsletter Service. Just send E-Mail to addme@avcomm.com.au.</p> <p><small>* Prices do not include shipping and include Australian Sales Tax. (if applicable)</small></p> | | |

a technical and marketing
advisory

memo

to the membership from your
industry trade association

SPACE Pacific

Satellite
Programme
Access
CommittEe



A trade association for users, designers,
installers, sellers of private satellite-direct
systems in the Pacific Ocean & Asia Regions

Death of a hacker -

He was a gifted computer whiz - one of the best, one who'd made the jump from illegal tinkering to the legitimate, potentially lucrative business of making codes crack-proof from hackers like himself.

But when Boris Floriciz was found hanging from a tree in a Berlin Park on October 22 (1998), his belt around his neck and his feet dragging on the ground, it drew attention even outside the tight-knit world of hackers.

His friends wonder whether he was caught up in the murkier side of the trade - one of spies, espionage, and black-market criminals. Was it a suicide as the police suspect? Or homicide?

Floriciz's friends wonder if he became a threat to someone on the wrong side of the business, leading to his death.

"His death was not a personal decision," Andy Mueller-Maguhn, a friend and fellow member of the Chaos Computer Club said. "For sure not. This was murder."

From childhood, Floriciz looked destined to be an engineer. He was always taking things apart to see how they worked. "Radios, televisions, clocks, the lawn mower - nothing was safe from him," his father told Stern Magazine.

He disassembled a telephone booth to get at computer data inside. He was the first hacker to crack the microchips on Deutsche Telekom telephone cards, used at pay phones in Germany. His home-made card reloaded as the credit ran out.

After getting caught in 1995 and sentenced to probation, Floriciz "felt the need to draw the line," says Mueller-Maguhn. He joined Chaos, a 10-year-old group of computer devotees, and he went back to college, earning his diploma in record time by developing a scrambler to encode telephone calls on high speed, digital lines. German media reports say Floriciz also was working on cracking codes for pay television - a booming business spreading across Europe. One of the key players is Rupert Murdoch, whose digital broadcasting research firm

NDS Ltd contacted Floriciz in 1996 about being a code-design consultant.

"He was an exceptionally talented engineer," said Margot Field, spokeswoman at the firm's London headquarters. NDS wanted to hire him but he couldn't accept the position because he had not yet graduated nor completed his compulsory (German) military service. NDS kept after Floriciz until mid-1998.

NDS was not the only one interested in Floriciz. His father says Floriciz talked several times about being approached by people he suspected worked for spy agencies, which are believed to have mined the 'hacker world' for talent in the past. Just a few months ago, Germany's spy agency tried to hire a hacker to get secrets out of Iran's military computers, the Chaos club reports. But the contact vanished when the hacker got Chaos involved.

Floriciz may also have attracted black marketers of counterfeit chips for telephone cards and mobile phones. Deutsche Telekom estimates it loses millions of dollars each year from counterfeit cards. And industry officials worry that TV decoder chips offer gangsters even bigger profits on the black market. Money was not a lure for Floriciz - he preferred to post his research on the Internet for all to see - and use.

"It was all the same to him if others raked in the bucks from what he developed," one friend Daniel told Stern Magazine. "The main thing for him was that he had proven what he was great at."

Mueller-Maguhn says Floriciz's open attitude about his work might have threatened those who didn't want competitors horning in on their business. "He had lots of jobs, but he didn't want to become a slave to one company. Maybe that was a problem."

Floriciz left his mother's apartment on October 17 (1998) at 2 PM. She didn't think he'd be gone long, because he didn't

MEMBERSHIP IN SPACE

Membership in SPACE Pacific is open to any individual or firm involved in the "satellite-direct" world in the Pacific and Asia regions. There are four levels of membership covering "Individuals," the "Installer/Dealer," the "Cable/SMATV Operator," and the "Importer/Distributor/Programmer."

All levels receive periodic programme and equipment access updates from SPACE, significant discounts on goods and services from many member firms, and major discounts while attending the annual SPRCS (industry trade show) held annually. Members also participate in policy creation forums, have correspondence training courses available, and their support makes possible the SPACE Pacific Report (weekly) television programme. To find out more, contact (fax)

64-9-406-1083 or use information request card, page 34,

this issue of SatFACTS. Page space within SatFACTS is donated each month to the trade association without cost.

take his beloved laptop computer with him. He never came back. Calls to his mobile telephone went unanswered.

A passer-by found his body five days later. His phone, keys, ID card and money were with him, evidence police say points to suicide. No sign of a struggle, nothing stolen, no drugs.

Police detectives waited patiently for test results - fingerprint fragments or chemical traces - before making a final determination. The Chaos Computer Club members were creating their own report which would be released at their annual convention. The death notice on the club's Web site states what Floriciz's friends believe happened:

"The circumstances under which he disappeared and his extraordinary capabilities lead us to the conclusion that he became a homicide victim."

Canal + Bouquet - the next business opportunity

As reported p. 2 and 34 here, the long anticipated Paris based Canal + ten channel pay-TV bouquet is scheduled to begin testing on Intelsat I701 (180E), Ku spot beam centred on Noumea (New Caledonia), on 1 November or thereabouts. Commercial operation is scheduled for "Christmas."

While Canal + may have been capable of making a decision in favour of launching this new service (which will also include 3 channels of RFO New Caledonia FTA programming as well), it has been two long years of dedication and devotion by SPACE Member Steffen Holz (Antenna'Cal Communications SARL, Noumea) which brought it to fruition. Holz, one of the more ardent supporters of SPACE, has been involved in our industry for about as long as SatFACTS and SPACE have been around. His firm is professional in every sense of the word.

Canal + is equally professional - actually larger than the Murdoch controlled pay-TV world by a few million subscribers. Their selection of Mediasat (not to be confused with Mediasat Sydney - the uplink operator) brand IRDs using something called Mediaguard CA is logical if little expected. Mediasat is a "branded-for-Canal +" Sagem built IRD, using a smart card approach, and totally controlled by Canal +.

As our forecast eirp table on page 34 indicates, the 180E steerable Ku beam "flows west" into significant portions of Australia. There is a positive attitude at Canal + concerning servicing customers beyond New Caledonia, Vanuatu, Wallis and Futuna (all French speaking regions). And Steffen reports a "conversation" ongoing about perhaps offering an English language version of EuroNews and EuroSports.

For a minority of enthusiastic viewers you will perhaps entice into a system, "hard core" triple-X rated adult programming will be the primary (if not only) reason for their subscription. Yes, there will be angry reaction, threats and fist shaking because the French adult programmers leave nothing to imagination (Steffen warns us in advance about this). And rights issues. Not all programming will be available in all markets - but some will be available in all. So we'll have the usual learning curve about which ones go where, and the usual attempts to "challenge" those rules.

Overall, this is one of the more positive new creations for 1999 - opening up pay television to an entirely new segment of the Pacific where previously there was none. The dishes are small, the equipment probably reasonable and if a viewer was really desperate, he or she could take a correspondence course in French. Our congratulations to Steffen Holz, proudly a Member of SPACE and an example for all of us that careful attention to detail does pay off.

Scientific Atlanta Professional Receivers

✓ 99 channels C or Ku band; ✓ Tuneable audio; ✓ Built-in RF signal level display; ✓ UHF modulated output; ✓ Baseband audio and video; ✓ 950 - 1450 MHz L-band; ✓ Original cost \$2500!

SURPLUS DEMO UNITS now \$150!!!

VIDEOSAT P/L, (61) (0) 2 9482 3100

2/28 Salisbury Rd, Hornsby, NSW 2077

Enquiries@videosat.com.au

DX Antenna DSA-646EIIA Receivers

Professional rack mount C/Ku band satellite receivers. Brand new, 40 units, A\$100 each, freight collect ex-Sydney. Also available - identical units in used condition at A\$50 each.

John Martin, + +61-2-9281-4481, Fax

+ +61-2-9212-4464, e-mail:

jmartin@compuserve.com

DISCOUNTS? Watch this space!!!

Exciting discounts on state-of-the-art digital DVB receivers - Discounts greater than your annual membership in SPACE (*) - to be announced soon.

AV-COMM Pty Ltd. e-mail *cgarry.avcomm.com.au*

(* YES - discounts available ONLY to SPACE members!)

PACE IRD50 Analog Cryptovision Receivers

Remanufactured, fully tested, serviced. On screen display, SCART outputs, remote control, C/Ku bands, UHF modulator, 920-2050 L-band, 14/18V polarity switching, 27 MHz IF bandwidth. A\$75 each, two for \$125 w/remotes and (untested)

Ku LNBF (+ freight). See *www.actec.com.au/ird50.hftml*.

Oh yes - stocking distributor for Winersat MATV/SMATV!

Advanced Circuit Technology

contact fax ++61-352-772-161 or email *actec@bigpond.com.au*

TEXT ONLY SatFACTS ADVERTISING

All advertising appearing on this page contributes towards keeping SPACE Pacific Report on your television set each weekend!
This size advertisement - perfect for disposing of surplus equipment - as low as US\$55 or Australia/New Zealand equivalent. Details from ++64-9-406-0651, e-mail *Skyking@clear.net.nz*

The CABLE Connection

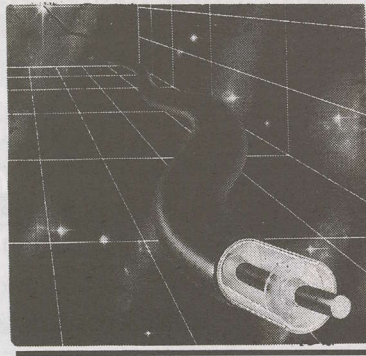

Understanding a "new" Ku band

Although we do not - at press deadline - have an advisory from RFO/Canal+ and Intelsat concerning the downlink operating frequency for the new I701/180E Ku service to include 3 FTA and 10 pay-TV digital programme channels, we can be certain that existing LNBS and feeds designed for the Optus satellites will not function for this new service. It is a matter of operating frequency.

Ku band has a number of versions. Optus B1 and B3 operate in the 12.25 to 12.75 GHz region. All services using either of these satellites falls someplace between those to points. Our satellite receivers do not tune these frequencies directly - rather they tune something we call "L-band" which in older days would have been known as "the satellite IF band." L-band is as a minimum .950 to 1.450 GHz (same as 950 MHz to 1450 MHz) and in more recently designed receivers/IRDs it is 0.950 to 2.150 GHz. If our receiver is going to tune-in the downlink frequency band, the actual downlink operating frequency must be "shifted" or "converted" to the L-band range our receiver actually tunes.

Intelsat 701 is a very flexible satellite and on board are four separate Ku-band transmission bands. Each is 250 MHz wide (whereas Optus satellites use a 500 MHz downlink width). The four "bands" which might be used for the new French services appear in the box at upper right (12.50-12.75 is not an option).

The first concern is that we have the correct (for the operating downlink band) LNB or LNBF. "Correct" means its input operating frequency range must correspond to the band actually used for the French service. Let us suppose, for discussion, the new bouquet is someplace within the frequency range of 11.45 to 11.70 GHz. What we have to do is shift or (down) convert this 11.45 to 11.70 region to someplace our receiver will tune. If the receiver tunes only .950 to 1.450 GHz, the answer to our quest is basic subtraction.

$$11.45 - .95 = 10.5$$

What is 10.5? The LO or local oscillator frequency for the LNB - to allow us to shift down to a receive frequency we can cope with. If 11.45 is the lowest frequency in the band, and .950 is the lowest L-band frequency, then with a 10.5 local oscillator built into the LNB - the top end of the 1701 frequency band (11.70) will come at:

$$11.70 - 10.5 = 1.2 \text{ GHz (1200 MHz).}$$

Fortunately for us, it is not necessary that we start 11.45 at .95 - all we have to do is land *someplace* between .950 and 1.450 and still have room left over for the top end of the frequency band at 11.7. For example:

$$11.45 - 9.75 = 1.7 \text{ (1700 MHz) and therefore 11.7 would equal 1.95 (1950 MHz).}$$

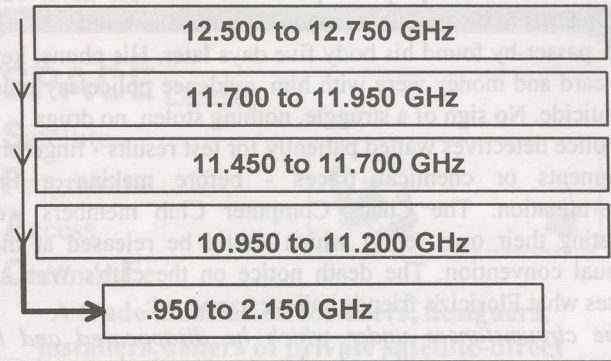

This is our first serious experience with a second Ku band in the Pacific. Europeans routinely use four or more distinctly different Ku bands, and there are dozens of LNB and LNBF products on the market to solve their reception combinations. One trick is to build LNB/LNBFs with two LOs inside, selected by a switching voltage or (kHz) signal.

And that brings us to the second challenge. Between 10.95 and 12.750 we have 1.8 GHz of spectrum space - equal to a 14% bandwidth (i.e., 1.800 is 14% of 12.750). Asking a feed horn, in whatever configuration, to produce optimised performance over a frequency bandwidth of 14% is asking a great deal. It can (and is) done - but with performance trade offs. For example - in C-band language, asking a feed that was designed to work well at 4.2 GHz to also work as well as 3.4

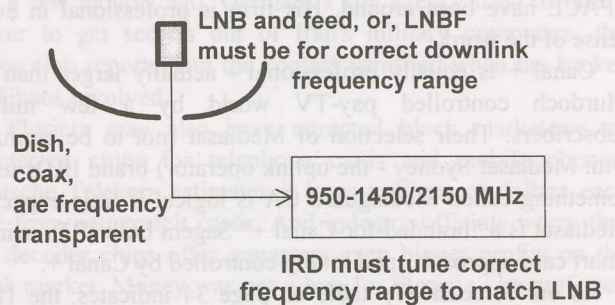

GHz (extended C-band) is quite a challenge. That works out to about a 19% bandwidth.

Virtually all of the off-the-shelf feeds we now have handy have in theory been optimised for the 12.25 to 12.75 GHz range of Optus. They will work, after a fashion, as low as 10.8 GHz but with about the same performance trade offs as we expect when we take a 4.2 GHz feed and try to use it at 3.4 GHz.

With a switchable LO LNB, "wide banded" to cover 10.8 to 12.75 GHz, and a "wide band feed" designed to cover the same range, you have the ingredients to be functional on any of the I701 capable Ku band downlink bands, as well as Optus

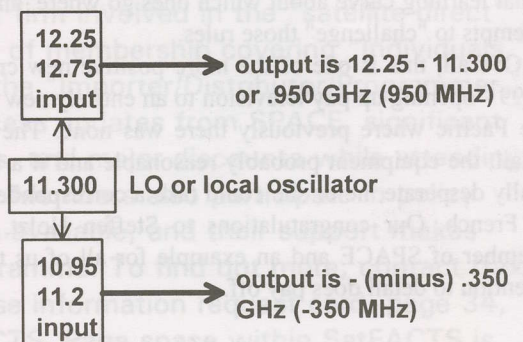

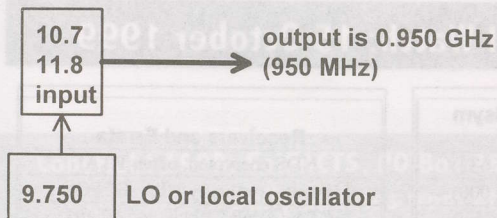

The goal is to select a LO frequency which places the down converted signal as close to the low end (950 MHz) as possible

B1 and B3. And if your DVB receiver has an L-band IF range covering .95 to 2.15 GHz, you can select from a range of available LNB/LNBF products to shift or downconvert the I701 Ku band signal down to something your receiver can tune-in.

There are warnings. If possible, select an LO frequency that keeps the L-band output as close to .950 as possible. Why? Because your downline cable losses are significantly lower at .950 than at 2.15 GHz. And your connector problems are reduced as well - an "F" fitting, for all of its attributes, really is not the best choice (although the only sensible choice) as we approach an L-band frequency in the 2.0 (2000 MHz) region.

If you select a dish size for the satellite that is weakest in your area (in Australia - this will be I701), equip it with a voltage/signal switching LO so that you can select the I701 or Optus downlink ranges at will, and put a "wideband" feed or LNBF on it, you are doing the correct thing to have multi-Ku band capability with a minimum of degradation.

TUNE US IN ...

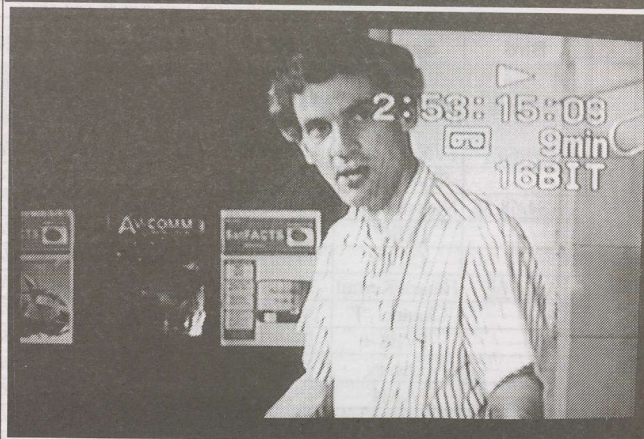

Show 9905: Robin Colquhoun (above) explains how the Dr Overflow software improves the Nokia series IRDs.

Show 9906: How the Uplink works - fascinating tour of a major uplink TT&C station.

Show 9907: How the uplink works - two. As well as TVRO pioneers.

Show 9908: Mark Long introduces you to "digital basics."

Show 9909: Mark Long reviews system install techniques.

It is your industry's "trade TV show" where you meet the people who make our technology happen!

On Mediasat B3 12.336Vt - see page 28 here.



MELBOURNE SATELLITES P/L

ACN 065 270 733
Established 1992

Direct importers and suppliers of the following world renown products.

KTI
ORBITRON
PATRIOT
JONSA
ANDREW

ECHOSTAR
SCIENTIFIC ATLANTA
NOKIA
IKUSI
DX

GARDINER
CALIFORNIA AMPLIFIER
MTI
CHAPARRAL
ADL

Full range of cables, splitters and connectors.

Phone, fax or write for our 1999 Product SA7alogue.

Sales/Warehouse - 84 Bayfield Road, Bayswater Victoria
Construction Services - 13 Elsum Avenue, Bayswater Victoria
Postal Address - PO Box 901, Bayswater 3153 Victoria Australia

Phone: (03) 9738 0888
Fax: (03) 9729 8276

User Friendly Site!

www.melbournesatellites.com.au

e-mail: sales@melbournesatellites.com.au

SatFACTS Pacific/Asian MPEG-2 Digital Watch: 15 October 1999

| Bird | Service | RF/IF & Polarity | # Program Channels | FEC | Msym | |
|---------------------|----------------------|----------------------------|--------------------|--------------|----------|-----------|
| I703/57E | Sky News | 4143/1007R | 1 | 3/4 | 5(.632) | |
| | CNBC | 4018/1132L | 1 | 3/4 | 6(.000) | |
| I704/66E | TV5, Adult 21 | 4055/1095R | 4 | 3/4 | 27(.500) | |
| | Sky News + | 3805/1345R | 4 | 3/4 | 22(.520) | |
| PAS4/68.5E | Nickelodeon+ | 4147/1003H | 1 reported | 1/2 | 24(.000) | |
| | BBC | 3743/1407H | 5 | 3/4 | 21(.800) | |
| | CCTV | 3716/1434H | up to 6 | 3/4 | 19(.850) | |
| Ap2/76E | Hmark/Kermit | 3720/1430H | 4 | 5/6 | 29(.270) | |
| | Channel "I" | 3823/1327V | 1 | 3/4 | 3(.570) | |
| | TVB8 + | 3849/1301H | 4 | 3/4 | 13(.238) | |
| | Disney | 3880/1270H | 3 | 5/6 | 28(.125) | |
| | AXN | 3920/1230H | up to 8 | 7/8 | 28(.340) | |
| Them3/78.5E | ITC | 3569/1581H | 1 | 3/4 | 10(.200) | |
| | MRTV | 3666/1484H | 1 | 2/3 | 4(.442) | |
| | UTV | 3920/1230H | 6 | 3/4 | 26(.662) | |
| | UTV/MCOT | 3880/1270H | 8 | 3/4 | 27(.500) | |
| | Mahar/DD1 | 3600/1550H | up to 89 | 3/4 | 26(.661) | |
| | Myanmar TV | 3666/1484H | 1 | 3/4 | 4(.442) | |
| | PTV bouquet | 3420/1730V | 2 | 3/4 | 6(.666) | |
| | TV Maldives | 3412/1738V | 1 | 1/2 | 6(.312) | |
| | Thai Global+ | 3425/1725V | up to 7? | 2/3 | 27(.500) | |
| | ST1/88E | NTSC bouq. | 3441/1709H | 2 | 3/4 | 5(.800) |
| Pacific DTH | | 3468/1682V | up to 30 | | 22(.000) | |
| MeSt 1/91.5E | Malaysia TV3 | 4147/1004H | 1 | 3/4 | 7(.030) | |
| As2/100.5E | Euro Bouquet | 4000/1150H | 5TV, 19r | 3/4 | 28(.125) | |
| | Reuters | 3909/1241H | 1 | 3/4 | 5(.632) | |
| | Hubei/HBTV | 3854/1296H | 1 | 3/4 | 4(.418) | |
| | Hunan/SRTC | 3847/1303H | 1 | 3/4 | 4(.418) | |
| | Guan./GDTV | 3840/1310H | 1 | 3/4 | 4(.418) | |
| | Inn. Mongolia | 3828/1322H | 2 | 3/4 | 8(.397) | |
| | Saudi Arabia | 3811/1339H | 1 | 3/4 | 3(.905) | |
| | APTIN A-O | 3799/1351H | 1 | 3/4 | 5(.631) | |
| | WTN Jer/Lon | 3790/1360H | 1 | 3/4 | 5(.631) | |
| | Reuters/Sing. | 3775/1375H | 1 | 3/4 | 5(.631) | |
| | WorldNet/US | 3764/1386H | 1 + 20 radio | 3/4 | 6(.100) | |
| | Liaoning/Svc2 | 3734/1416H | 1 | 3/4 | 4(.418) | |
| | Jiangxi/JXTV | 3727/1423H | 1 | 3/4 | 4(.418) | |
| | Fujian/SETV | 3720/1430H | 1 | 3/4 | 4(.418) | |
| | Hubei TV | 3713/1437H | 1 | 3/4 | 4(.418) | |
| | Henan/Main | 3706/1444H | 1 | 3/4 | 4(.418) | |
| | As2/100.5E | TVSN | 4033/1117V | 1 | 3/4 | 4(.298) |
| | | Sky Racing | 4020/1130V | up to 3TV | 1/2? | 18(.000)? |
| | | EMTV | 4006/1144V | 1TV, 2 radio | 3/4 | 5(.632) |
| Jilin Sat TV | | 3875/1275V | 1 | 3/4 | 4(.418) | |
| HeiLongJiang | | 3834/1316V | 1 | 3/4 | 4(.418) | |
| JSTV | | 3827/1323V | 1 | 3/4 | 4(.418) | |
| Anhui TV | | 3820/1330V | 1 | 3/4 | 4(.418) | |
| Shaanxi/QQQ | | 3813/1337V | 1 | 3/4 | 4(.418) | |
| Guang/GXTV | | 3806/1344V | 1 | 3/4 | 4(.418) | |
| Fashion TV | | 3796/1354V | 1 | 3/4 | 2(.533) | |
| Feeds | | 3785/1365V | 1 | 3/4 | 5(.632) | |
| Myawady TV | | 3766/1384V | 1 | 7/8 | 5(.080) | |
| Saudi TV1 | | 3661/1489V | 1 | 3/4 | 7(.128) | |
| As3S/105.5E | | Arirang TV | 3755/1395V | 1 | 7/8 | 4(.418) |
| | | Star TV | 3780/1370V | 17(+)-TV | 3/4 | 28(.100) |
| | Star TV | 3860/1290V | 14(+)-TV | 3/4 | 27(.500) | |
| | Star TV | 3880/1270H | 12(+)-TV | 7/8 | 26(.850) | |
| | CNNI | 3960/1190H | 4(+)-TV | 3/4 | 26(.000) | |
| | Star TV | 4000/1150H | 7(+)-TV | 7/8 | 26(.850) | |
| Cak1/107.5E | Indovision (S-band) | 2.536, 2.566, 2.596, 2.626 | 33(+)-TV | 5/6 | 20(.000) | |
| | Shanghai TV | 4106/1044V | 1 | 2/3 | 4(.443) | |
| C2M/113E | Space TV | 4000/1150H | 12TV, radio | 3/4 | 26(.667) | |
| | C Net Taiwan | 3760/1390H | 11TV, radio | 5/6 | 21(.091) | |
| | RCTI | 3475/1675H | 1 | 3/4 | 8(.000) | |
| JcSAT3/128E | Miracle Net | 3990/1160V | 3 up to 6 | 5/6 | 12(.997) | |
| | Asian bouquet | 4106/1050H | up to 8 | 7/8 | 30(.000) | |

3570 (2)
26.666, 314
+3539
IndSat 2E 88E
3531/VF-
6.000/314
3957/DDJ
TRC/Desh-
6.000/314
45

| Receivers and Errata |
|----------------------------------------|
| NDS encrypted, often FTA |
| Feeds - typically FTA (SCPC) |
| FTA (Adult 21 believed off air) |
| Sky News 24 hr, sport, feeds; some FTA |
| Status unknown - was testing FTA |
| FTA; 2 audio channels |
| FTA |
| PowVu, typ. CA |
| Tests, FTA |
| PowVu, CA |
| PowVu, CA - operating? |
| Tests, promos, some FTA |
| FTA |
| FTA; difficult to load |
| Irdeto (MOSC cards were available!) |
| Irdeto (MOSC cards were available!) |
| FTA (has included Indian, Egypt) |
| FTA, may not be active |
| FTA, new service, testing |
| FTA (reaches SE Australia) |
| FTA |
| Open TV, Cosa TV |
| +3550, 3632 - some FTA |
| tests, possibly permanent, FTA |
| FTA (TV5 teletext) |
| FTA, occasional feeds |
| FTA SCPC, teletext |
| FTA SCPC, teletext |
| FTA SCPC, radio APID 81 |
| FTA: #1 Chinese, #2 Mangolian |
| FTA SCPC; "Ch 1" (not same as 3661V) |
| FTA SCPC (news feeds) |
| Mostly CA; some FTA |
| FTA & CA |
| FTA; multiple radio channels |
| FTA SCPC |
| FTA SCPC, teletext |
| FTA SCPC, + radio |
| FTA SCPC |
| FTA SDCPC, + radio |
| FTA SCPC - difficult to load |
| (Irdeto) CA; 1 & 3 occ. FTA |
| PowVu CA; poor signal level |
| FTA SCPC, + radio |
| FTA SCPC |
| FTA SCPC, + radio |
| FTA SCPC |
| FTA SCPC |
| FTA SCPC |
| FTA SCPC, now easy to load |
| FTA & CA, feeds |
| FTA SCPC - difficult to load |
| FTA SCPC; also see 3811H-not same |
| FTA SCPC; very strong signal |
| NDS CA (Pace DVS211) |
| NDS CA (Pace DVS211) |
| NDS CA (Pace DVS211) |
| PowVu CA; some FTA fed channels |
| NDS CA (Pace DVS211) |
| NDS CA using RCA/Thomson, Pace |
| IRDs; improved reliability since June |
| FTA SCPC, difficult to load |
| CA uses "floating sequence" system |
| CA but subscriptions available |
| FTA SCPC; may not be permanent |
| PowVu; TBN #3 FTA, some CA |
| CA and FTA, Japan, Taiwan, China |

3990

| Bird | Service | RF/IF & Polarity | # Program Channels | FEC | Msym |
|--------------|----------------|------------------|--------------------|-----|---------------|
| LMI AP1/130 | THT+NTV | 3675/1475L | 2 + 1 radio | 3/4 | 6(108) |
| Ap1A/134e | Gansu TV | 3769/1381V | 1 | 1/2 | 6(930) |
| Ap1/138e | Reuters | 3742/1408V | 1 | 3/4 | 5(632) |
| | Viacom | 3860/1290V | up to 6 | 3/4 | 30(000) |
| | SDTV | 3980/1170V | 1 | 3/4 | 4(686) |
| Optus B3/156 | Mediasat | 12.336V | 6TV, 3+ radio | 2/3 | 30(000) |
| | Aurora | 12.407V | | 2/3 | 30(000) |
| | Aurora | 12.532V | | 2/3 | 30(000) |
| | Aurora | 12.595V | | 3/4 | 30(000) |
| | Aurora | 12.720V | | 3/4 | 30(000) |
| | Austar/Foxtel | 12.438H | | 3/4 | 29(473) |
| | Austar/Foxtel | 12.564H | | 3/4 | 29(473) |
| | Austar/Foxtel | 12.626H | | 3/4 | 29(473) |
| | Austar/Foxtel | 12.688H | | 3/4 | 29(473) |
| Optus B1/160 | ABC NTfeed | 12.256V | 1TV, 3 radio | 3/4 | 5(026) |
| | Central 7 | 12.354V | 1TV | 3/4 | 3(688) |
| | Imparja TV | 12.367H | 1TV, 3 radio | 3/4 | 5(424) |
| | Sky NZ | 12.391/418V | | 3/4 | 22(500) |
| | Sky NZ | 12.518/546V | | 3/4 | 22(500) |
| | Sky NZ | 12.644V | | 3/4 | 22(500) |
| | Imparja feed | 12.367H | 1 | 3/4 | 5(424) |
| PAS8/166E | Pacific Time | 12.286V? | 10TV | 3/4 | 26(470) |
| | ABCInterch. | 12.312H | 1 | 3/4 | 6(978) |
| | ABCInterch. | 12.321H | 1 | 3/4 | 6(978) |
| | Pacific Time | 12.326V? | 8TV | 3/4 | 27(500) |
| | ABCInterch. | 12.330H | 1 | 3/4 | 6(978) |
| | Pacific Time | 12.366V? | 9TV | 3/4 | 26(470) |
| | TARBS | 12.526H | 12+ TV | 3/4 | 28(067) |
| | NHK Joho | 4065/1085H | 5TV, 1 radio | 3/4 | 26(470) |
| | CalBqt/PAS8 | 3940/1210H | up to 5TV | 7/8 | 27(690) |
| | CNNI | 3780/1370H | 3, up to 5 TV | 3/4 | 25(000) |
| PAS2/169E | GWN Perth | 12.265V | 4TV, 7 radio | 1/2 | 16(200) |
| | TelstraBendig | 12.300V | 2 | 1/2 | 21(997) |
| | TCS-Singap. | 4183/967V | 2 | 1/2 | 6(620) |
| | HK PowVu | 4148/1002V | up to 8 | 2/3 | 24(430) |
| | NBCHonKn | 4093/1057V | 5, up to 7 | 3/4 | 29(473) |
| | Feeds | 3942/1208V | 1 or 2 | 2/3 | 7(497) |
| | ESPN USA | 3860/1290V | 7TV, 2 data | 7/8 | 26(470) |
| | Middle East | 3778/1372V | 4 | 3/4 | 13(331) |
| | Service 1 | 3761/1389V | 1 | 3/4 | 6(620) |
| | BBC + TFC | 3743/1407V | 3 to 5 | 3/4 | 21(800) |
| | CCTVPowV | 3716/1434V | 5 typical | 3/4 | 19(850) |
| | NTV Japan | 4174/976H | 1 | 3/4 | 5(632) |
| | Feeds | 4138/1012H | 1 | 3/4 | 6(620) |
| | CNNI HK | 3996/1154H | 1 | 3/4 | 9(998) |
| | Feeds | 3867/1183H | 1 | 2/3 | 6(618) |
| | 7thDyAdven | 3957/1193H | 1TV, 14 audio | 3/4 | 7(000) |
| | Feeds | 3939/1211H | 2 (typ NTSC) | 2/3 | 6(620)/7(498) |
| | Cal PowVu | 3901/1249H | up to 8 | 3/4 | 30(800) |
| | Disney | 3804/1346H | 3 | 5/6 | 21(093) |
| | Discovery Sing | 3776/1374H | 8 typ | 3/4 | 21(093) |
| | Satcom 1-6 | 3743/1407H | up to 5 | 7/8 | 19(465) |
| 1702/177E | AFRTS | 4177/973LHC | 8TV, 12+ rad | 3/4 | 26(694) |
| | ThaiBouquet | 12.650H | up to 3 TV | 1/2 | 17(800) |
| 1701/180E | TVNZ | 4195/955RHC | 1 | 3/4 | 5(632) |
| | TVNZ/BBC | 4186/964RHC | 1 | 3/4 | 5(632) |
| | TVNZ | 4178/972RHC | 1 | 3/4 | 5(632) |
| | TVNZ/APTN | 4170/980RHC | 1 | 3/4 | 5(632) |
| | AFRTS Pac. | 4175/975LHC | 3 radio (only) | 2/3 | 3(679) |
| | RFO-Canal+ | 4095/1055L | 7TV, 5+ radio | 3/4 | 27(500) |

| Receivers and Errata |
|------------------------------------------|
| NTV 2818/2819, THT 2946, 2947 |
| FTA SCPC (NT, Aust only) |
| FTA SCPC (NT, Aust only) |
| FTA, CA (NT, Aust only) |
| FTA SCPC (NT, Aust only) |
| PowVu but mostly FTA ; TRT, Thai5 |
| CA, \$65 smart card required (p. 25) |
| CA, \$65 smart card required (p. 25) |
| CA, \$65 smart card required (p. 25) |
| CA, \$65 smart card required (p. 25) |
| CA, subscription available Australia |
| CA, subscription available Australia |
| CA, subscription available Australia |
| CA, subscription available Australia |
| FTA, Sydney -30 minutes time zone |
| FTA, purpose here unknown |
| FTA, purpose here unknown |
| NDS CA, subscription available NZ |
| NDS CA, subscription available NZ |
| NDS CA, subscription available NZ |
| FTA, difficult to load, not full time |
| Viacess CA, some FTA at times |
| PowVu, FTA, news feeds |
| PowVu, FTA, news feeds |
| Viacess CA, some FTA at times |
| PowVu, FTA, ABC Melbourne feeds |
| Viacess CA, some FTA at times |
| 'MDS' CA, IRDs useless other svcs |
| PowVu CA & FTA; subscription avail |
| PowVu CA & FTA |
| PowVu, FTA at this time |
| PowVu CA-WA only, D9234 required |
| PowVu CA, private, not available |
| PowVu FTA |
| PowVu CA, some FTA |
| Philips MPEG-2, FTA |
| (PowVu) FTA, occ. feeds |
| PowVu CA, Ch 12 bootloader updates |
| FTA - low level, difficult to load |
| (PowVu) FTA, occ. feeds |
| (PowVu) CA & FTA - BBC #3 FTA |
| (PowVu) FTA, # pgm chs varies |
| FTA SCPC feeds (occasional use) |
| FTA occasional feeds |
| Reverse link HK to Atlanta, feeds, FTA |
| FTA occ. (sport) feeds |
| 1900-2030UTC; not daily, PowVu FTA |
| FTA-typ. NTSC-occ. sport, shuttle |
| (PowVu) CA & FTA |
| PowVu CA |
| PowVu CA |
| currently FTA, lowlevel, Mid East feeds |
| PowVu CA |
| Thai5 service, tests, FTA |
| DMV/NIL occ. feeds, typ CA |
| DMV/NIL occ. feeds, typ CA |
| DMV/NIL occ. feeds, typ. CA |
| DMV/NIL occ. feeds, typ. CA |
| PowVu CA radio, very strong level |
| #1, 2 CA - rest FTA-France to Polyn. |

SatFACTS Digital Watch: Supplemental Reference Data / October 1999

| Bird | Service | RF/IF & Polarity | # Program Channels | FEC | Msym |
|-------------|---------------------|------------------|--------------------|-----|----------|
| (1701/180E) | SPN Nauru | 4081/1055L | 1 | 3/4 | 4(.730) |
| | NZ Prime TV | 4024/1126L | 1 | 2/3 | 6(.876) |
| | RFO Polycast | 3858/1292L | 1 | 3/4 | 4(.566) |
| | TVNZ (TL) | 3854/1293R | 1 | 3/4 | 5(.632) |
| | TVNZ | 3846/1304R | 1 | 3/4 | 5(.632) |
| | 10 Australia | 3765/1385R | 6 | 7/8 | 29(.900) |

| Receivers and Errata |
|---------------------------------|
| FTA; currently off the air |
| PowVu CA; Auckland net feeds |
| FTA SCPC; East Hemi Beam-Tahiti |
| SCPC, mixed CA & FTA, feeds |
| SCPC, mixed CA & FTA, feeds |
| PowVu CA & FTA; #3 TBN |

BOUQUETS - FTA vs. CA: Listings here show SCPC (single channel per carrier) and MCPC (multiple channels per carrier) digital transmissions which "more or less" conform to the MPEG-2 DVB "standard." Unfortunately, "conforming to the standard" is interpreted differently by the various transmission equipment suppliers - of which, Scientific Atlanta is the most notorious with its PowerVu proprietary (that means "unique to SA") method of creating MPEG-2. If you want to see REAL MPEG-2 DVB-Compliant (as in world standard) signals - try AsiaSat 2, European Bouquet (4000/1150Hz). SA "modifies" their PowerVu format in an attempt to force each programmer using its uplink equipment to also use its proprietary (PowerVu) receivers. PanAmSat, closely linked to Scientific Atlanta, virtually insists that any digital service user of their satellites use PowerVu format transmission equipment. The good news is that some clever non-PowerVu receiver designers and receiver software writers have created "quasi-PowerVu" decoding routines which in many cases outperform the PowerVu originals. If your use requires access to one or more PowerVu CA (conditional access) service, you have no choice but to purchase a PowerVu receiver. If you are only interested in FTA (free to air) PowerVu services, there are many lower cost options (see below).

All services listed in bold face (i.e. **SPN Nauru**) are FTA. When MCPC services are FTA, they are also listed bold face (i.e. **Euro Bouquet**). When there are mixed CA and FTA programme channels in a MCPC bouquet, see right hand column for a bold face indication of this (i.e. **some FTA**). The primary (mostly or total) FTA MCPC bouquets are as follows: PAS4/68.5E: CCTV (3716H); Thaicom 3/78.5E: Mahar (3600H), Thai Global (3425V); As2/100.5E: European Bouquet (4000H); Optus B3 /156E: Mediasat (12.336V); PAS8/166E: NHK Joho (4065H), California Bouquet (3940H), CNNI (3780H); PAS2/169E: NBC Hong Kong (4093V), Middle East (3778V), BBC + (3743V), CCTV (3716V), California PowVu (3901H), Satcom 1-6 (3743H); Intelsat 701/180E: RFO (4095LHC), 10 Australia (3765RHC). There are far more SCPC FTA digital services than MCPC FTA digital services.

MPEG-2 DVB Receivers:

(Data here believed accurate; we assume no responsibility for correctness!)

ADI MediaMate. FTA, NTSC+PAL outputs. (Pacific Digital Sys. Pty Ltd, tel 61-2-8765-0270)

AV-COMM RB3100. FTA, excellent sensitivity (review SF May 1998); new version Sept. '99. Av-COMM Pty Ltd, 61-2-9949-7417.

Benjamin DB6600-CA. FTA, Foxtel/Austar w/CAM+card. Try Steffen Holzt ++687-438-156.

Grundig DTR1100. Mfg by Panasat (SA), very similar to Panasat 630; out of production, Irdeto capable. See Av-COMM above.

Humax F1-CI. Primarily sold for TRT(Australia), does (limited) PowerVu, other claims unsubstantiated.

Hyundai-TV/COM. HSS100B/G (Pacific), HSS-100C (China) FTA. Different software versions; 2.26/2.27 good performers, 3.11 and those with Nokia tuners also good; later 5.0 not good. SATECH (V2.26) 61-3-9553-3399; Skandia (V3.11) 61-3-9819-2466.

Hyundai HSS700. FTA, PowerVu, SCPC/MCPC. Review SF March 1999. Kristal Electronics, 61-7-4788-8906.

Hyundai HSS800CI. FTA, Irdeto (with CAM) + other CA systems, PowerVu, NTSC. Kristal Electronics (see above).

MediaStar D7. FTA, preloaded w/ known services, exc. software (review SF July 1998). MediaStar Comm. Int. 61-2-9618-5777

MultiChoice (UEC) 660. Essentially same as Australian 660, not grey market contrary to reports. Sciteq tel 61-8-9306-3738

Nokia "d-box" (V1.7X). European, FTA, may only be German language, capable of Dr. Overflow software. Tricky to use.

Nokia 9200. When equipped with proper CAM, does Aurora, pay-TV services provided software has been "modified" with Dr Overflow or similar program (www.BAKKERELECTRONICS.COM). Has factory 12 mo. warranty. Peter Older, tel 61-3-5133-7911, mobile 61-0418-386287

Nokia 9500/9600. Numerous versions for different world parts; not distributed in Pacific but assistance from Av-Comm Pty Ltd.

Nokia 9800. Latest single chip version (August 1999), with CI and Irdeto capable. No hands on experience yet.

Pace DVS211. NDS CA (no FTA) for Star Asia, previously used for Indovision. (Solution 42, 61-2-9820-5962)

Pace DGT400. Originally Galaxy (Now Foxtel+Austar). Irdeto, some FTA with difficulty (Foxtel Australia 1300-360818)

Pace DVR500. Original DGT400 modified for NBC (PAS-2) affiliate use, with CAM equivalent to DGT400 but more reliable.

Pace "Worldbox" (DSR-620 in NZ). Non-DVB compliant NDS CA including Sky NZ, no FTA; similar "Zenith" version.

Pacific Satellite DSR2000. Advises no longer current model (see. p. 2, here); Clone of Mediastar D7 (see above)

Panasat 520/630/635. MCPC FTA, Irdeto capable, forerunner UEC 642, 660. Out of production, spares fax ++27-31-593-370.

Panasonic TU-DS10. FTA + Irdeto CA; one of 2 IRDs approved by Optus for Aurora, but no longer available in Australia.

Phoenix 111, 222. PowVu capable, NTSC, good graphics, ease of use. (SF 111 review May 1999). SATECH - see below.

Phoenix 333. FTA SCPC, MCPC, analogue + dish mover. Detailed SF review Nov. 1998. SATECH 61-3-9553-3399.

PowerCom. FTA, PowVu, NTSC, excellent sensitivity. NetSat 61-2-9687-9903.

PowerVu (D9223, 9225, 9234). Non-DVB compliant MPEG-2 unless loaded with software through ESPN Boot Loader (see below). Primarily sold for proprietary CA (NHK, GWN+ PAS-2 Ku, CMT etc). Scientific Atlanta 61-2-9452-3388.

Praxis/DigiMaster 9600 MKII/9800AD. FTA, PowVu+analogue, withdrawn from sale in Pacific (was Skyvision-below)

Praxis 9800 ADP. FTA SCPC/MCPC, PowVu, analogue, positioner. SF review Dec '98; withdrawn from Pacific sale (below).

Prosat 2102S. FTA SCPC/MCPC, NTSC/PAL, SCART + RCA. Sciteq 61-8-9306-3738.

Samsung DSR2400. FTA, reported not sensitive, recently released Asia - no Pacific sources.

SatCruiser DSR-101. FTA SCPC/MCPC, PowVu, NTSC/PAL. (Skyvision Australia 61-2-6292-5850, Telsat 64-6-356-3749)

SatCruiser DSR-201P. FTA SCPC/MCPC, PowVu, NTSC/PAL, analogue, positioner - review this issue (Skyvision - see above).

Skandia SK888 (aka DigiSkan-SMS). FTA MCPC, Irdeto CAM+software upgrade. Out of production; Skandia 61-3-9819-2466

UEC642. Designed for Aurora (Irdeto), approved by Optus; limited other uses. Nationwide 61-7-3252-2947.

UEC660. Upgraded UEC642, used by Sky Racing Aust., Foxtel-limited uses for FTA. (Nationwide - above).

Yuri HSS-100C. FTA, clone of Hyundai, V2.27 software custom to Australia (Nationwide-above).

Accessories:

Aurora smart cards. Sold independent of IRD purchase by Sciteq (\$65), other sources require IRD purchase 61-8-9306-3738.

PowerVu Software Upgrade: PAS-2, 3860/1190V, 26.470, 7/8; Tune pgm ch 12 and follow instructions (do not leave early!)

SatFACTS Pacific/Asian FTA ANALOGUE Watch: 15 October, 1999

Copyright 1999: SatFACTS, PO Box 330, Mangonui, Far North, New Zealand (<http://www.satfacts.kwikkopy.co.nz>)

| BIRD/Location | RF/IF & Polarity | Service | Errata |
|----------------|-----------------------|-------------------|-----------------|
| I703/57E | 3808/1342R | Udaya TV | |
| | 4052/1098R | WorldNet | VOA subers. |
| | 4178/972L | MTA Inter. | |
| I604/602/60E | 4166/984 | various feeds | |
| I704/66E | 3765/1385R | tests | |
| | 4015/1135L | Mongolia | (SECAM) |
| PAS4/68.5E | 3743/1407V | RTPi | (+ radio suber) |
| | 3864/1286V | BBC World | |
| | 3907/1243H | Sony TV | Hindi |
| | 4034/1116V | Doordan | (various) |
| | 4087/1063H | CNNI | |
| | 4110/1040H | TNT/Cartoon | |
| | 4113/1037V | Series Ch. | |
| | 4182/968H | MTV | |
| PAS7/68.5E | 3470/1680V | test signal | |
| AP2R/76E | 3745/1405V | Vasta Music | (P5 in NSW) |
| | 3760/1390H | TEN tests | |
| Thaicom3/78E | 3871/1279H | TVT | |
| | 3760/1390V | Army TV | |
| | 3690/1460V | MRTV | |
| | 3685/1465H | Myanmar TV | |
| | 3616/1534V | ETN | |
| | 3594/1556V | AGK | test card |
| | 3576/1574V | ATN Bangalr | Bengali |
| | 3554/1596V | RAJ Plus | |
| | 3536/1614V | Punjabi TV | (occ service) |
| | 3514/1636V | Falak TV | |
| | 3489/1661H | Vasta Music | occ tests |
| | 3465/1685V | RAJ-TV | |
| Express 6/80E | 3672/1478L | TK Rossija | (north beam) |
| InSat 2E/83E | 3481/1669V | Sun TV | |
| | 3575/1550V | Vijay/Asianet | aud. 5.5/6.6 |
| | 3810/1340V | DD1-Tamil | " |
| | 3850/1300V | DD1-National | " |
| | 3930/1220V | DD2 Metro | " |
| | 3970/1180V | Teluga 1 | " |
| | 3998/1152V | sport feeds | " |
| | 4035/1115V | Sun TV | " |
| | 4060/1090V | Surya/Sun TV | " |
| | 4093/1057V | DD7 | " |
| ChnStr1/87.5E | 3875/1275H | occ feeds | P4 NSW, Ntsc |
| ST1/88E | 3550/1600V | test card | |
| | 3582/1568V | Nila TV | (vintage TV) |
| CIS S6/90E | 3675/1475R | RTR1 | P3 NSW |
| | 3875/1275R | Orbita 1 | |
| | 3916/1234R | RTR II | |
| | 3935/1215R | Orbita II | |
| MeSat-1/91.5E | 3710/1440H | VTV1,2, 4 | |
| | 3880/1270H | RTM-1 | |
| InSat 2B/93.5E | 4165/985H | India Metro | NSW on 3.7m |
| | 4125/1025V | India National | NSW on 3.7m |
| | 4080/1070V | DD7 (Tamil) | |
| | 4070/1080H | DD9 | |
| | 3970/1180V | DD9 (Kan.) | |
| | 3882/1268V | DD1 | |
| | 3840/1310V | DD? | |
| | 3762/1388V | DD4 | |
| AsSat2/100.5E | 3642/1508H | ERTU Egypt | |
| | 3660/1490V | feeds, tests | |
| | 3680/1470H | feeds | |

UN 1

02a-09a
150V
use w/center

PAS4/68.5E
150V
6.6

3881-3922
30V
Test (used)

| BIRD/Location | RF/IF & Polarity | Service | Errata |
|---------------|------------------|----------------|-----------------|
| (As2/100.5E) | 3860/1290V | feeds | |
| | 3885/1265H | WorldNet | VOA subers |
| | 3960/1190H | CCTV4 | |
| | 3980/1170V | RTPi | +5 radio svcs |
| CIS S21/103E | 3675/1475R | RTR | |
| | 3875/1275R | Vrk Apt | |
| AsSat3S/105.5 | 3660/1490V | Z-Marathi | audio 6.6 |
| | 3680/1470H | CETV | |
| (temp FTA) | 3800/1350H | Star Sport | NTSC |
| (temp FTA) | 3840/1310H | Channel [V] | NTSC |
| (temp FTA) | 3920/1230H | Phoenix Ch | NTSC |
| | 3940/1210V | Zee India | |
| | 3980/1170V | Zee TV | |
| | 4140/1010V | Angla Bangla | |
| | 4060/1090V | Zee Cinema | (Starcrypt) |
| | 4100/1050V | PTV2/World | |
| | 4120/1030H | CCTV | NTSC |
| PalapB2R/10E | 4000/1150H | TVRI | Telekom replace |
| PalapC2/113E | 4183/967V | TPI/TVRI | |
| | 4160/990H | (France) TV5 | |
| | 4140/1010V | Brunei + feeds | |
| | 4120/1030H | MTV Asia | |
| | 4080/1070H | Herbalife | 2100HK/NTSC |
| | 4040/1110H | CNBC | |
| | 3970/1180V | CNNI | |
| | 3880/1270H | Aust ATN7 | |
| | 3840/1310H | TVRI | tests |
| | 3765/1385H | NBC, CNBC | feeds |
| | 3742/1408V | RCTI | English suber |
| ChinS 6/125E | 4085/1065V | feeds | seldom seen |
| JeSat3/128E | 3768/1382V | feeds | occ., P5 NZ |
| | 4085/1065V | test card | NTSC. 6.8 aud. |
| Ap1A/134E | 4160/1050V | CETV | |
| | 3980/1170V | CETV1 | |
| | 3900/1250V | CETV2 | |
| Ap1A/138E | 4160/990H | CCTV7 | |
| S7/140E | 3675/1475R | ORT Moscow | +/-4d. inclined |
| | 3875/1275R | feeds, tests | |
| Ag2/146E | 3787/1363H | GMA | P1/2 s. eqtr |
| Me2/148E | 4080/1070H | test card | occ. use |
| PAS8/166.5E | 3880/1270V | test card | not full time |
| | 3865/1285H | Napa test card | not fulltime |
| PAS2/169E | 3940/1240V | Napa test card | |
| 1802/174E | 4166/984R | Feeds | |
| | 4177/973R | Feeds | |
| I702/177E | 4166/984R | Feeds | inc. KBS Korea |
| | 4187/963R | Occ. feeds | |
| I701/180E | 3810/1340R | Occ. feeds | |
| | 3841/1309L | RFO | East Beam |
| | 3845/1305R | Occ. feeds | inc. from USA |
| | 3930/1220R | USA net feeds | FTA & encrypt |
| | 3975/1175R | Occ. feeds | |

103300

Oddball Formats

| | | | |
|------------|------------|-----------------|----------------|
| PAS4/68.5E | 3785/1365V | Discovery India | BMAC |
| | 3860/1290H | ESPN India | BMAC |
| Ap2/76E | 3960/1190H | HBO Asia | GI DigiCipher2 |
| C2/113E | 3930/1220H | Filip. Peo. Net | GI 1.5 MPEG |
| Ap1/138E | 4100/1050V | ESPN | BMAC |
| PAS2/169E | 3836/1341H | ABS/CBN | GI 1.5 MPEG |
| | 3989/1161V | Fox/Prime | SA1.5MPEG |

BEGINNER'S CORNER

Common mistakes a beginner makes: #1) Buying too small a dish. The more you learn about Satellite TV reception, the bigger your TV viewing universe becomes. The larger and more accurate your dish, the greater your system sensitivity. Nothing - no super duper receiver, no special LNB, no hot-dog feed will substitute for the largest dish your family, neighbours and local council will tolerate (see SPACE Pacific Report, TV Show 9904). System "gain" (sensitivity) is directly related to dish size and dish quality. #2) Buying a "cheap" dish. Dishes that look like a bargain are not - usually. The surface accuracy of the dish - how well it emulates a parabolic shape - is key to performance. The dish surface accuracy is directly related to the structural integrity of the dish design. A dish that bends, flops in the wind, is easily misshapen by wind or your dog rubbing up against it will lose the required parabolic shape and in the process your system sensitivity will diminish. A "big" floppy, mis-shaped dish with reduced performance is a worse choice than a smaller, well designed dish (see SPACE Pacific Report, TV Show 9903). #4) Selecting the wrong "feed." The feed is the small antenna device attached to the LNB (or a part of the LNBF) which catches the satellite signal that bounces from and is focused by the parabolic "reflector." Each dish has design parameters - of which f/D (focal length to dish diameter) is crucial to feed antenna selection. Signal caught by the reflector is bounced or redirected to the feed antenna where it is captured and carried to the low noise amplifier inside of the LNB. The feed manufacturer tells you what "f/D" the feed is intended to work best with, and the dish manufacturer tells you what the dish's f/D is. Check one specification against the other and choose the feed that matches the dish (see SPACE Pacific Report, TV Show 9902).

ADVANCED INFORMATION

Irdeeto conditional access has been compromised by European card manipulators. Nokia model 9200 receivers equipped with version 2.X or higher CAMs are popular with hackers because when modified with "blocker" software, MOSC (modified original smart cards) appear at this stage to be immune from ECM (electronic counter measure) attempts by pay-TV operators to shut-down unauthorised cards. Virtually all of the hacker information exchange takes place using Internet. SatFACTS will not list Pacific region hacker sites but does recommend for your own education the Internet online discussion group: <http://www.thoic.com/cgi-bin/forumdisplay.cgi?action=topics&number=15&SUBMIT=Go>. Australian law is 20 years plus behind current technology, and very possibly is not modern enough to deal with current hacking techniques and technology. New Zealand law, in comparison, very specifically makes it a violation to deal in hacked products or services. Providers of MOSC devices operate from Africa, Europe and Asia and anyone dealing with these firms must send funds out of country. Card hackers do not accept credit cards and most will not accept bank checks (personal checks are NEVER accepted). Hackers of MOSC products used in Australia operate outside of normal business society, do not reveal their true identity nor location, and frequently change their (Internet) E-mail addresses. European hacked cards have reached a level of acceptance that includes local satellite dealers and installers actually stocking (for resale) cards for local customers. European satellite magazines (such as What Satellite, Tele-Satellit) routinely carry full page, four colour smart card advertisements. Nothing approaching this level of openness exists elsewhere although North American groups do make wide use of Internet. An Australian trade association of pay-TV operators has petitioned legislators to create new laws to deal with the threat of open distribution of hacked products; on September 2, (Australian) Attorney General Daryl Williams asked the House to approve 'Copyright Amendment (Digital Agenda) Bill 1999'. Details of this pending legislation are available at <http://www.aph.gov.au>. On September 21st, South African based piracy card supplier Rolf Deubel (alias MadMax) was reported arrested in Bangkok, Thailand. Mindport Australia, supplier of Irdeeto encryption, believes this has broken the supply line of MOSC cards for Foxtel, Austar into Australia (see p. 14 here).

TUNING IN THE INDUSTRY'S TV PROGRAMME

SPACE Pacific, the Asia-Pacific industry membership trade association, has produced (and continues to produce) a series of one hour television programmes. These "SPACE Pacific Report" shows, hosted by Bob Cooper, cover a range of topics of interest to installers and enthusiasts. Show numbers and content are as follows: #9901- Spectrum Analyser techniques, #9902- Feeds and LNBS, #9903- Dish antenna designs and problems, #9904- The dish marketplace, and, "tiny parts," #9905- Dr Overflow (Nokia) software, #9906- How the uplink works (tour of RCA's Vernon Valley site), #9907- Uplink Two, including uplink transmitters, #9908- Digital Basics (Mark Long), #9909- Real World Installs (Mark Long). "Report" is broadcast by Mediasat on Optus B3, 12.336Vt, ad-hoc channel 3 (SR 30.000, FEC 2/3) with the following coming-weeks schedule: **Sunday October 17** - Show 9905 - 0400-0500UTC (1700NZST, 1400AET, 1200 WA), repeating 0800-0900UTC; **Sunday October 24** - Show 9906 - same times as October 17; **Sunday October 31** - Show 9907 - 0300-0400UTC (1600 NZST, 1400 AEST, 1200 WAST), repeating 0700-0800UTC; **Sunday November 7** - Show 9901 - same times as October 31; **Sunday November 14** - Show 9902 - same times as October 31; **Sunday November 21** - Show 9903 - same times as October 31. SPACE Pacific attempts to pre-announce which show(s) will appear through the SatFACTS Web site prior to each weekend (<http://www.satfacts.kwikcopy.co.nz>). Shows are digitally mastered and VHS copies are available from SPACE Pacific - see insert card between front cover and page 1 here.

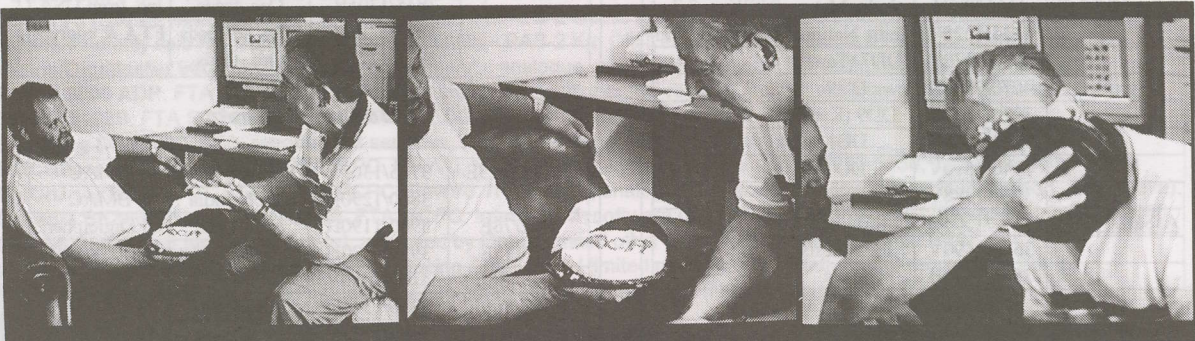

WITH THE OBSERVERS

AT PRESS DEADLINE

Telekom 1, replacing Indonesia (Telekom) B2R at 108E, should be firing up as or shortly after you read this. Testing at 122.5E showed surprising coverage south of the equator, east to Japan. As a Telekom satellite, only very minor video use is expected - but hope springs eternal! See Telekom listing here.

ApStar 2R/76E: CCTV9 reported again operating 3883/1267Hz, SR12.836, FEC 3/4 FTA. Channel "I" testing reported 3823/1327Vt, SR 3.570, FEC 3/4, FTA.

AsiaSat 1/122E: "Test signal, 4150/1000Hz in P3 to P4 range here; strange when this satellite was at 105.5E we did well at P1." (Leach, NSW)

AsiaSat 2/100.5E: KIBC-TV, uplinked from Subic Bay (Philippines) has shutdown permanently citing lack of advertising support (for update on SPACE Pacific Report, see p. 28). Newsforce Australia feeds (from East Timor?) on 4192/968Vt, SR 6.110, FEC 3/4. Occasional Reuters feeds on 3909/1241Hz, SR 5.632, FEC 3/4, FTA.

AsiaSat 3/105.5E: "Z-Marathi TV P5 on 3.657/1493, audio 6.58." (McLeod, NZ). Alpha TV Bangla new on 4140/1010Vt.

Intelsat 701/ 180E: "Found TRT within RFO bouquet for a period of time" (4095/1055LHC, SR 27.500, FEC 3/4)." (Gabriel Chingue, Tahiti)

Intelsat 801/ 174E: "Lots of news feeds out of East Timor and Asia here; NHK, Philippines TV, TVNZ, others (4166/984R, 4177/973R)." (Ernie Wright, Australia)

LMI AP-1/130E: New PIDs for 3675/1475LHC - NTV 2818, 2819 and THT 2946, 2947. Also - APID 2945 is Sport FM. Analogue service of NTV has ceased, now digital only. "With THT and NTV both on 75 watt (capable) super transponder, signals are really powerhouse - 0.0 E6 in Auckland." (Francis Kosmalski)

JcSat 3/128E: "Very strong (P5) analogue feeds including USA CBS network news on 3768/1382Vt, NTSC." (McLeod, NZ) "4100/1050Hz, SR 30.000 and FEC 7/8 has Taiwan, Japan and China services FTA and CA." (Ivory, Hong Kong)

Measat 1/91.5E: Malaysian TV3 is testing on 4147/1004Hz, SR 7.030, FEC 3/4.

Optus B1/160E: "ABC NT feed, 12.256Vt, dropped in level by approximately 8 dB late September, now only larger dish possible in many areas." (Bill Richards, Australia). "New broadcaster interchange channel, 12.702Vt, FTA analogue." (David Pemberton) Imparja test card reported 12.367Hz, Vpid 1040, Apid 1041 plus radio on Apid(s) 1056/1058 and 1059.

Optus B3/156E: "At 0545UTC September 25, data stream for Mediasat froze and their ad-hoc channel had 'Please Wait!' slide up. Afterwards, whole bouquet more difficult to load." (Adams, Wellington - they switched from PowerVu to NDS



BANGLA TV, one of several new FTA analogue Indian services appearing on AsiaSat 3 - rapidly becoming "the satellite" for Indian programming. Below - Thai 5 stylistic ID from testing on Mediasat B3 bouquet.



PCRs at that point. Answer is to re-enter PID/PCR numbers with PCR 7-less than VPIDs and everything will play OK - but only do this on problem channels such as TRT [PCR becomes 1853 - was 1860], Mega [becomes PCR 1753, was 1760] - editor)

WITH THE OBSERVERS: Reports of new programmers, changes in established programming sources are encouraged from readers throughout the Pacific and Asian regions. Information shared here is an important tool in our ever expanding satellite TV universe. Photos of yourself, your equipment or off-air photos taken from your TV screen are welcomed. TV screen photos: If PAL or SECAM, set camera to f3.5-f5 at 1/15th second with ASA 100 film; for NTSC, change shutter speed to 1/30th. Use no flash, set camera on tripod or hold steady. Alternately submit any VHS speed, format reception directly to SatFACTS and we will photograph for you. Deadline for November 15th issue: November 5 by mail (use form appearing page 34), or 5PM NZT November 6th if by fax to 64-9-406-1083 or Email to

Skyking@clear.net.nz.

Moments you may have missed - live

When Trinity Broadcasting Network (TBN) "switched on" their live-from-California feed through 180's 701 they cut to a group at Saturn Cable TV where TBN is now carried full-time to exchange blessings. Not so blessed was CNN feed through PAS-2 where unexplained interruptions in programming, replaced by the uplink ID slide shown here, were common during the equinox period. Another PanAmSat mystery?

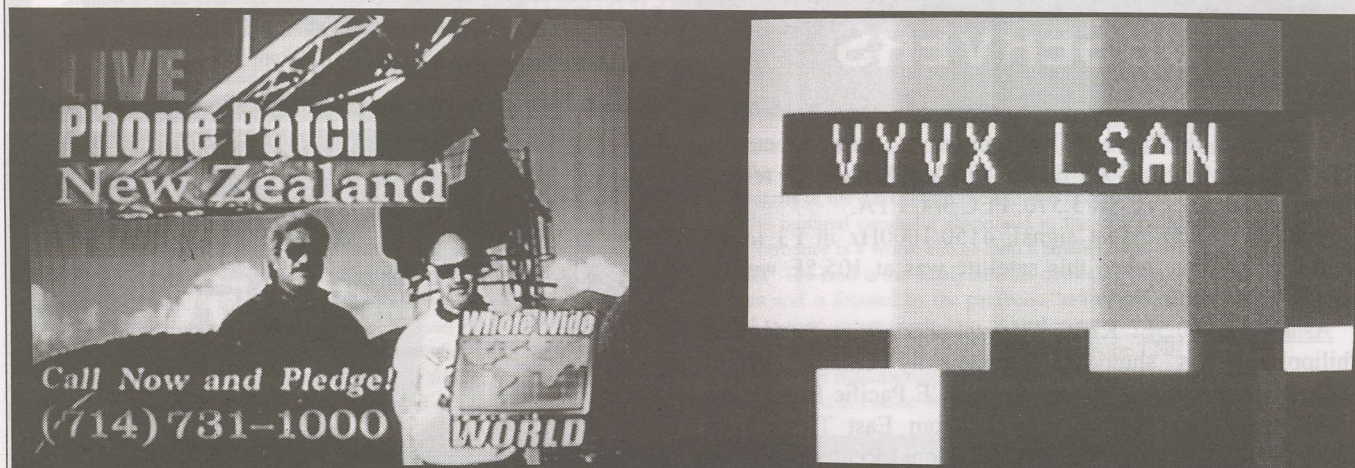

Palapa C2/113E: Malaysian TV3 is now gone from 3900/1250Vt (see Me-1 here). For the next time they drop CA - Space TV bouquet 3760/1390Hz SR is now 26.667.

PAS 2/169E: CMT within California bouquet FTA status during September - was a "computer fault" at Napá uplink, corrected 1 October (now CA again). Satellite went down for three hours September 11 (1300 UTC), no official explanation but insiders say TT&C operator (flying satellite) made mistake and satellite lost "earth lock," going into uncontrolled spin on its own axis. Recent - if not current: California bouquet 3901/1249Hz - (1) CMT CA, (2) CBS + Ad Hoc 1, (3) Chile TV feeding TARBS CA, (4) Ad Hoc 2, (5) BBC World (Vpid 1560, Apid 1520), (6) Bloomberg TV, (7) TARBS "Future" TV, (8) Moslem TV.

PAS 8/166E: "We are not supposed to see vertical side here - P3 (on 3m) analogue test card on 3880/1270Vt, audio 6.18." (McLeod, NZ) "Digital test SCPC on 4145/1005Vt, SR 5.956, FEC 3/4 - right on edge w/3m dish." (McLeod, NZ). "Tests for Discovery Channel on 3900/1250Hz, SR 21.087, FEC 3/4 had up to 6 programme channels, two of which briefly FTA, then testing stopped." (Dave Nolan, Australia) "Add to services available through UEC 642, from TARBS (12.526Hz) following FTA radio stations: (1) DZMM and (2) DWRR - both Manila, (3) EGPT, (4) EGAR and (5) TBA - not in use." (AI, Qld) "EWTN now loads as 3 channels (3940/1210Hz, SR27.690, 7/8) - 7, 8 and 10." (Mathews, NZ)

ST 1/88E: "3441/1709Hz (Tp1B), SR5.800, FEC 3/4, two NTSC services - Open TV and Cosa TV. Of perhaps interest - Open TV includes some strange programming including nude Karaoke singing!" (Hermosa, Sultanate of Oman) Check out 3468/3550/3632 MPEG-2 digital here - 'Pacific DTH' reported with 30 programme channels (all in Chinese) - SR 22.000 for 3468, 19.700 for others (but subject to change!).

Telekom 1/108E: "Test signals on 3645/1505Vt, 4022/1128Vt, 4180/970Hz, 3960/1190Hz approaching P5 on 3.7m dish when satellite was at 122.5E - now to see what it is from permanent 108E." (Leach, NSW - TV programming is not their priority - data, telephone is - editor) "Beacon signal at 4195/955Hz is quite strong." (David Pemberton, Australia)

Thaicom 3/78E: AGK test card reported 3594/1556Vt; ITC testing 3520/1630Hz, FTA (Vpid 513, Apid 630). Nile Drama

has replaced Sun TV3600/1550Hz (Vpid 513, Apid 660 - SR is 26.661, FEC 2/3 but programme channel number and content varies almost daily - editor). PTV World, PTV Sports testing 3420/1730Vt, SR 6.666, FEC 3/4.

Commentary: "I recently changed from a circular/linear feed to a MTI brand linear only and what an amazing difference - P2 signals went to P3.5, P4 to P5" (David Leach, NSW). "Prices of digital receivers with CI in Middle East are continuing downward trend. Eurostar brand with CI for Irdeto and Viaccess costs US\$210 while Vortec with CI capable of Irdeto, Conax, Viaccess, Nagravision and Cryptoworks US\$270. Both have twin card readers. An Irdeto CAM with built-in card reader is between US\$75 and \$100. Nokia 9200S are down to US\$100 range but are being sold with 1.0 version software. After a month, distributors try to convince users to upgrade the software with FTA 2.0 and then another upgrade with ES 2.0 - each upgrade costing US\$55! The Nokia 9800S is the most expensive here - US\$700 range." (Gregorio V. Hermosa, Jr. as gregorih@squ.edu.om) "My house, land and telephone call back agency has been sold - we leave Norfolk January 10. In theory, the island still needs someone to do Foxtel, general satellite, VCR and TV set repair plus all things electronic. My trading names and basic business is still available to someone willing to become an islander." (Charles Shaw, Norfolk Island as seashore@ni.net.ng) "Humax F1 CI receiver works with Aurora and pay-TV and 2 cards inserted, using Irdeto module CIM ver 00.03, software ver 2.05 (CI). Observations - slow to change channels, possibly because of CAM version and will sometimes lock up when changing polarity - only fix is to turn it off, then reboot." (BP, WA) "In May purchased Hyundai HSS700 as second receiver so could play two separate RFO programmes off of I701 simultaneously. The HSS100 plays Tom 1, 2 and 3 perfectly but the HSS700 has sensitivity problems. Strangely, this is only with the RFO feeds - on all other satellites, it plays perfectly. When levels are below 7.5 on HSS100 scale, the 700 simply refuses to play." (Jacques Monty, Sydney) "Cal Amp LNB pricing has gone up 30%, perhaps because they are now the only 11.3 GHz DRO (dielectric resonant oscillator) design discrete LNBs left in Australian marketplace and they are making the most of that situation." (Peter Merrett) "Group in Auckland is offering Zee TV channels, PTV with 3m range dishes imported from India - along with LNBs and

feeds and receivers." (Laurie Mathews - no slight on India but none of this looks very appealing - editor). "TRT programme guide on Internet as <http://www.trt.net.tr/tv/trtgunler.asp>" (Craig Sutton, NZ). "Advanced menu in Austar IRD is 2878." (Shane Lynd, Australia) "It is a natural evolution that (IRD) manufacturers would prefer to standardise production by introducing one box which would be compatible with any encryption system. The solution is a common CA CAM known as PCMCIA. UEC and ADB (used by Austar) have gone the other direction with the whole CA support hard wired to the main receiver board. Their advantage is slightly lower cost per IRD, disadvantage is the service provider is locked into the same encryption system for ever and ever. PCMCIA CAMs are available in Irdeto, Viaccess, Videoguard (NDS) and others. In Europe one can subscribe to two different pay-TV operators and with 2 CAMs can view say an Irdeto service and a Viaccess service using the same IRD. In the Australian outback, a person wanting Aurora + pay-TV ends up with the UEC + Optus card and a DGT400 or equivalent + Austar card. When Aurora is working properly on the newer IRDs - very soon - their 2 CAM slots will be able to do the lot." (Jacob Keness, Opac) "The only thing 'grey' about the Multichoice boxes being imported by Sciteq is the colour of the IRD. The Multichoice appears to run as well as the UEC, and a tad faster. My units have the RF modulator set for the South African band plan, ch 38 on Australian TV, and the RF output was down by a couple of dB from the UEC version. The general housekeeping menu lacks a channel deletion facility although channel shuffling is allowed. Things I liked: When you swap cards in the Foxtel units, the receiver goes through a tedious rescan of services; the Multichoice does not do this.

The Launch Pad

AsiaSat L-band (1452-1492) radio now scheduled to 105E 18 February
 InSat 3B will co-fly with AsiaStar also 18 February
 NSS-K (95E, 30 Ku) delayed to June 2000

Commentary:

Satellite launches for the Pacific and Asia have fallen behind schedule as the region struggles to find the correct balance between satellites operational and satellite business available. Many projects are adding 12 to 24 months to their projected launch dates to work out these operational and economic problems.

And the SCART sockets worked (the Foxtel do not). A very good owners manual is included and it works fine on Foxtel as well as Optus Aurora." (LA, Australia) "From AsiaSat 2, I actuated the dish to C2 using the positioner on my Palcom and up pops C-net. I realise both the Euro bouquet and C-net use the same downlink frequency, polarity and FEC; however, Euro uses SR of 28.125 while C-net is 26.667. In the Hyundai's SNR guide, both are the same. Can anyone explain?" (Steve Johnson, NZ)

AUSTRALIAN?

Av-Comm Pty Ltd. has the "best" service for subscriptions to SatFACTS Monthly and Coop's Technology Digest!

Tel 02-9949-7417 or

Email cgarry@avcomm.com.au

Proudly a sponsor of SPACE Pacific Report!

JACOBSON'S



THE NEW GENERATION OF DIGITAL
 SAT. RECEIVER IS HERE!
 НОВОЕ ПОКОЛЕНИЕ ЦИФРОВЫХ СПУТНИКОВЫХ
 РЕСИВЕРОВ!
 9800S

UNIQUE HIGHLY INTEGRATED ONE-CHIP SOLUTION WITH A TEN TIMES BETTER
 PROCESS CAPACITY....

MAKE SURE YOU BUY THE BEST! ASK US WHERE YOU CAN GET IT!

УНИКАЛЬНОЕ ВЫСОКОИНТЕГРИРОВАННОЕ РЕШЕНИЕ С ДЕСЯТИКРАТНЫМ
 УВЕЛИЧЕНИЕМ СКОРОСТИ ОБРАБОТКИ ИНФОРМАЦИИ....

БУДЬТЕ УВЕРЕНЫ - ВЫ ПОКУПАЕТЕ ЛУЧШЕЕ!

СПРОСИТЕ НАС, ГДЕ ВЫ МОЖЕТЕ ЭТО ПРИОБРЕСТИ!

NOKIA

Receiving Equipment
 Direct to home

EMITOR AB

Test equipment
 and accessories

Q2b

Digital cable-TV head
 equipment
 and Microwave links

ELCON

Multi switches

SMW

Digital professional LNB

Channel Master

Satellite Antenna

JACOBSON'S, авторизованный дистрибьютор в следующих странах: Россия, Беларусь, Украина, Молдова, Грузия, Армения, Азербайджан, Казахстан, Туркмения, Киргизия, Таджикистан, Эстония, Латвия и Литва.

NedraId S ■ 59197 Motala ■ SWEDEN ■ Phone: +46 141 220 331 ■ Fax: +46 141 220 111 ■ Website: www.jacobsons-t.s ■ E-mail: info@jacobsons-t.se
 Мы говорим и читаем по-русски! ■ Tel: +46 141 220 060 ■ Mob: +46 706 80 06 24 ■ Ask us for catalogue!

AT

Sign-off

Black Spot report-

Sometimes you have to think like a politician to get things done. Australian Federal Member for Braddon (a district in Tasmania) *Sid Sidebottom* apparently recognises an issue which has many in his electorate angry at Canberra. What better way to endear himself to his constituents than to ask them for advice!

The North-West coastal region of the island of Tasmania has notoriously poor broadcast reception. Not just television, but radio, mobile telephones - anything sent through the air from local - terrestrial - transmitters. In his electorate newsletter for September, Sidebottom includes a survey form asking residents to tell him about the quality of their telecommunications service. 40,000 people, in an estimated 11,000 residences, are being queried with postage paid reply cards. The survey form is in response to "complaints about non-existent television reception and mobile phone blackspots" he says he has received. He further writes:

"I was hoping some money would have been available from the further sale of Telstra to address the issue in regional areas like the North-West coast, but unfortunately, the problem continues to be overlooked.

"The Howard Government says money from the sale will give Tasmania access to advanced telecommunications systems yet for many they can't even get something as basic as proper television reception.

"Those experiencing problems don't need too be reminded that television reception in numerous parts of our region is very poor while SBS-TV still remains out of reach for many smaller communities.

"Those services and others like Triple J radio are taken for granted in major metropolitan areas, but are either sub standard or simply non-existent in many parts of the North-West. Mobile telephone blackspots are to numerous to list and it is a continuing source of frustration."

The survey form asks about four separate television service channels and the region has been asked to comment on the quality of reception for each.

Of course MP Sidebottom is aware of the Aurora programme and the availability of the same 7-9-10 network services via Ku band dish systems. And perhaps if his survey results are as strong as many industry participants in Tasmania anticipate, he could well end up urging that WIN/Tasmania and Southern Cross be somehow subsidised for their own Aurora allocation. You will recall that Imparja made a strong bid to be the 9-10 Networks provider in Tasmania (see SF for June - p. 18: "Could Alice Springs become the TV capital of Australia?"). You will also recall that when Imparja and Central-7 began to sign up hundreds of Tasmanian homes, the ABA decided they were in over their head and put a lid on further installations in what they called "grey areas" pending approval from Parliament. No, that approval; has not yet

No postage stamp required
if posted in Australia.

BUSINESS REPLY POST
Form 100
Postage and fee will be paid on delivery

SID SIDEBOTTOM MP
PO Box 826
Burnie Tas. 7320

TELECOMMUNICATIONS BLACKSPOT AUDIT

The intention of this audit is to identify major blackspot areas where coverage is either non-existent or very poor

(Please complete the survey form below and return postage paid)

TELEVISION

The following TV stations are not available where I live

Southern Cross Win ABC SBS

How I rate television reception where I live

| | Difficult to Watch | Unwatchable |
|-------------------|--------------------------|--------------------------|
| ABC | <input type="checkbox"/> | <input type="checkbox"/> |
| SBS | <input type="checkbox"/> | <input type="checkbox"/> |
| Southern Cross TV | <input type="checkbox"/> | <input type="checkbox"/> |
| WIN TV | <input type="checkbox"/> | <input type="checkbox"/> |

General Comments:

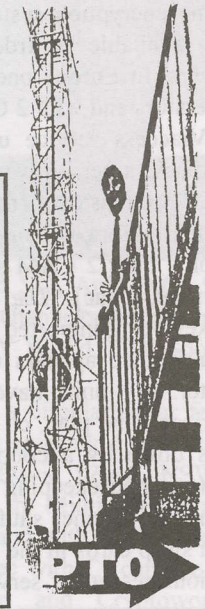

come and legislation to clarify the legal authority of the ABA to issue such approvals is buried in Parliament behind a long line of proposed telecommunication bills going nowhere at this time.

There is of course a solution to this problem - Triple J, SBS, ABC, and the 7-9-10 networks are *already available* on the Aurora satellite service. Plus much more. The Tasmanian WIN and Southern Cross television services could be easily added to the present Aurora bouquet and the families who at the moment will have to forego being a part of the national pride attached to hosting the 2000 Summer Olympics could have quality television reception very rapidly.

What MP Sidebottom probably does not yet realise is that while the snowy, ghostly, terrestrial analogue reception may be "difficult to watch" (his survey questionnaire description) now, when WIN and Southern Cross and SBS and ABC transition to the COFDM digital format, all of the people who now rate TV as "difficult" will instantly discover it is "unwatchable." Those who have been following our in-depth firsthand reports in Coop's Technology Digest of the COFDM/digital developments in the USA and Europe already know what Australia has yet to learn: DVB-T (terrestrial digital reception) is no different than below threshold DVB-S (satellite digital) service. When the signal level is weak, or the transmission path interrupted, unlike analogue where you may still be able to make out a picture and decipher the sound - there is *no reception* at all. "Unwatchable" takes on an entirely new meaning with digital as the screen goes blue and you sit in front of the box wondering when the reception will "start" again. When these poor folks learn the truth about their future entertainment options, they may decide to elect some new political leaders.

THE 1999 SATELLITE EXPLOSION IN THE PACIFIC/ASIA!

13 New French services coming on I701 Ku / Stay tuned with SatFACTS!

- ENTER my 12 MONTH subscription to SatFACTS starting with November 15th issue (rates below)
 ENTER my 36 MONTH subscription to SatFACTS starting with November 15th issue (rates below)

NAME _____
Company (if applicable) _____
Mailing address _____
Town/city _____ Country _____

Amount to send: 1 year - NZ\$60 (inside New Zealand) / A\$96 (inside Australia) / US\$60 (outside of NZ and Australia) or 3 years - NZ\$140 / A\$220 / US\$150 if by cheque. VISA or Mastercard? See form below and return with order. Return to: **SatFACTS, PO Box 330, Mangonui, Far North, New Zealand** or if by VISA or Mastercard fax to 64-9-406-1083

IF YOU ARE IN AUSTRALIA - See AV-COMM Pty Ltd Advert p. 31!

USE THIS FORM ONLY WHEN CHARGING ON VISA/MASTERCARD

Please charge my **VISA/Mastercard** as follows:

- ONE Year of SatFACTS MONTHLY (NZ\$60, A\$96, US\$60)
 THREE Years of SatFACTS MONTHLY (NZ\$140, A\$220, US\$150)
 SATELLITE TELEVISION: The Booklet (NZ\$10, A\$12, US\$10)
 One Year of COOP'S TECHNOLOGY DIGEST (NZ\$125, A\$125, US\$125)
Indicate charge card type: VISA Mastercard

Name (as it appears on **VISA / Mastercard**) _____
VISA/Mastercard Number _____
VISA/Mastercard expiration date _____

Instructions: If ordering by mail, return this complete (3-part) card or a copy of same (to **SatFACTS, PO Box 330, Mangonui, Far North, New Zealand**); if order by FAX, send full card as a single sheet to **64-9-406-1083**

ALL COPIES OF SatFACTS Monthly are sent via Air Parcel Post world-wide!

SUPPLEMENTAL MATERIALS from SatFACTS MONTHLY: Order Form

- SATELLITE TELEVISION: The Booklet.** Excellent introduction to home dish ownership for the layman, including major contributions from the father of geostationary satellites - famed science fiction writer *Arthur C. Clarke*. The perfect tool to help the satellite system seller explain home satellite TV to the layman consumer. From **SPACE Pacific**. NZ\$10 / A\$12 / US\$10, airmail.
- COOP'S TECHNOLOGY DIGEST.** For the really serious enthusiast, investor, business person in satellite television and allied leading edge technologies. Ten issues each year, jam-packed with information you will not find anyplace else. "Coop" routinely culls more than 60 publications world-wide, terribly expensive newsletters, Internet and his hundreds of private contacts to keep you right at the leading edge of technology on the **REAL** changes underway in telecommunications. Conveniently issued near the **first of the month**, creating an excellent time-line-filler between the mid-month issues of SatFACTS. Now in the **6th year**, airmail world-wide. Normally NZ/A/US\$250 per year - for SatFACTS subscribers special 50% discounted price of NZ/A/US\$125.

OBSERVER REPORTING FORM - Due November 5, 1999

- NEW programming sources seen since October 1st: _____
- Changes (signal level, transponder, programming content) in pre-existing programming sources since October 1st: _____
- OTHER (including changes in your receiving system): _____

NOTE: Please use P1 - P5 code when describing signal levels and receiver IF/RF settings.

Your Name _____
Town/City _____
Make/size dish _____ LNB _____ Receiver _____

Your email address _____ if you have one!

RETURN: SatFACTS, PO Box 330, Mangonui, Far North, NZ, fax 64-9-406-1083, Email Skyking@clear.net.nz

RFO / Canal + I701 at 180E Detail (clip and post)

Scheduled test start date: 1 November

Intelsat I701 at 180E using first-time turned-on steerable spot beam operating in 10.700 - 11.800 frequency range (exact downlink frequency and MCPC parameters posted on <http://www.satfacts.kwikkopy.co.nz> as soon as known - probably before you read this). Vertical polarity but remember the polarity skew to your location! Yes - you will probably have to order in a new LNB/LNBF and feed for this one. Contact for subscription: Steffen Holz, tel ++687-28.96.84, fax ++687-41.52.40, e-mail antenne-cal@canl.nc

Programming: 13 channels total, Viaccess CA of which 3 RFO channels will be FTA, 10 Canal + channels by subscription (exact figure not known at this time - around A\$110 per month). Included will be EuroNews, EuroSport, movie services, travel service, children's channel and more. Oh yes - an "Adult" French origin "hard-core" channel promoted as "*not the Anglo-Saxon everyday stuff*" - whatever that means!

Equipment required: In addition to Mediasat (with Mediaguard CA) IRD. appropriate 10.7 - 11.8 GHz LNB and feed, a dish. **What size:** Forecast footprints suggest the following: Noumea (New Caledonia) - 50 dBw/0.68m; Vanuatu - 48.5 dBw/0.82m; Brisbane, Norfolk - 47 dBw/0.9m; Fiji, Sydney - 45 dBw/1.16m; Melbourne - 42 dBw/1.61m; Wallis/Futuna Islands, Alice Springs, Cairns - 40 dBw/1.95m; North tip North Island (NZ) - 39 dBw/2.1m; Auckland, Solomons - 36 dBw/2.8m; northern portion South Island, NZ - under 30 dBw and not practical.

IS it just a COINCIDENCE
Members of SPACE have more work
than they can handle?



YES - send me information about how joining SPACE Pacific can lead me to more, profitable work!

NAME _____

Company affiliation (if any) _____

Mailing address _____

Town/city _____ postal code _____ Country _____

Sky Vision Australia

A Proudly Australian owned and operated company



SAT CRUISER DSR-101 MPEG 2 DVB / POWER Vu RECEIVER

***Latest Model – New Features
Best value receiver in Australia !***

Trade Price - quoted to established dealers

- √ The ideal consumer orientated receiver with features that will please the enthusiast !
- √ Pre-programmed with all active TP's from Asiasat 2, Palapa, PAS 2 ,PAS 8 and more
- √ 10 spare user defined satellite positions for future satellite launches
- √ Simplified manual TP entry – TP Frequency is the only required parameter !
- √ Auto Symbol rate – Auto FEC – Auto PID's – Auto Polarity (LNBF)
- √ Satellite naming/editing – Channel naming/editing
- √ Alternate audio channels accessible from remote control
- √ On-board NTSC – PAL 50 Hz convertor – compatible with any PAL TV
- √ On-board Digital TELETEXT decoder – no need for Text capable TV
- √ 5 language menu - English (default) Spanish / Italian / French / German
- √ Consumer friendly graphical interface – Easy to install !
- √ UHF Ch 21-69 Software controlled RF Modulator – Low spurious emissions
- √ Low threshold dual bandwidth tuner – Dual SAW filter IF stage
- √ C Tick certified to comply with Australian Communications Authority standards
- √ Ultra reliable SMPS module – not a single reported failure to date !
- √ Full colour photographs and screen shots available from our web site
- √ 12 month replacement warranty – With an optional extended warranty plan
- √ Feel free to call one of our friendly staff for more information !

DSR-201P Analog/Digital/Positioner receiver ..*Trade Price - quoted to established dealers*

Export – Wholesale – Trade sales

Web Site: <http://www.bigfoot.com/~skyvision>

E-mail: skyvision@bigfoot.com

Tel: 02 62925850

Fax: 02 62925890

Millennium 2000

Full featured low threshold analog satellite receiver

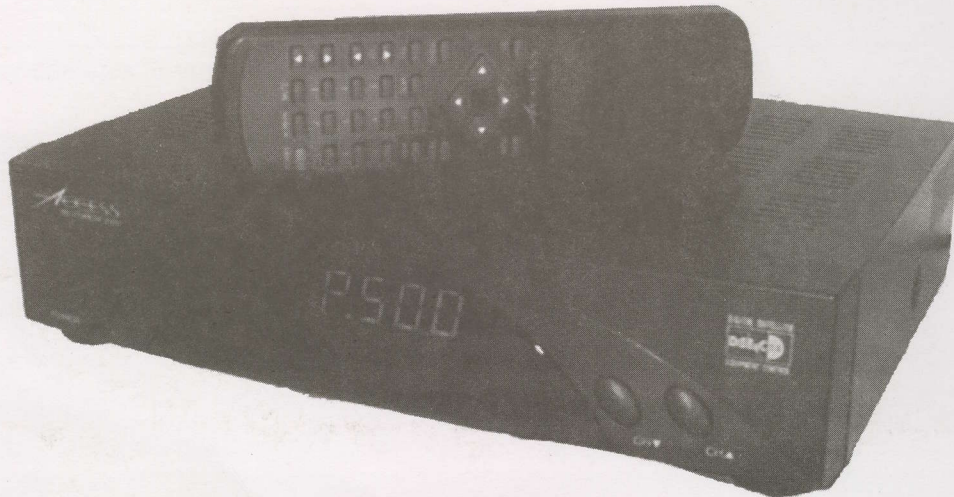

Features:

- On Screen Display 4 Language (English, French, Turkish, Arabic)
- 500 Channels Programmable
- 4 Digit display
- Favorite Channel Function (16 CH)
- Channel Copy Function
- Full Function Remote Control

Video:

- 32 Steps Low Threshold programmable
- Built-In Video Deviation Control Function (4 Steps)
- PAL/MAC/FILTERED/CANAL+ Decoder Interface

Audio:

- Switchable Audio Bandwidth (130/280/330/400KHz)
- 32 Steps Audio Volume Control Adjustable
- Multiple Audio De-Emphasis Control (50 μ SEC/75 μ SEC/J17/Dnr)
- Stereo & Mono all Audio Sub-Carrier (5.00~9.00MHz) receivable
- Panda-1 Compatible HIFI Stereo Super-DNR Sound Systems
- Audio Left & Right Individual Tuning System

Input:

- C/Ku-Band Switchable & Wide Band Tuner 900~2150 MHz
- 2 Input 2 Bandwidth (27/18MHz)
- Down-Link(Transponder) Frequency Direct Tuning System
- LNB L.O.F Select Function (5.150/9.750/10.000/10.750/11.000/11.475GHz & UNI-LNB-HI ,LO)
- L.O.F. Adjustable (+/-15MHz) Function
- Automatic Universal-LNB Control System
- LNB Pulse 22KHz & 60Hz Switching Programmable
- Diseqc 1.0 Built-in
- Multiple LNB control 0/12V Switchable
- Mechanical Polarizer

Output:

- 3-Scart In & Out & VCR Auto Loop Through
- 4-Phone Jack (Video, Audio L/R, Decoder)
- PLL RF Modulator 21 ~ 69 CH
- RGB D2-MAC Scart Interface Connection

Power:

- Switching Mode Power Supply (90 ~ 260VAC)

Dimensions:

- Small Chassis (280 X 200 X 65mm)

These quality products distributed by:



Phone: +61 8 9306 3738 Fax: +61 8 9306 3737
sales@sciteq.com.au http://www.sciteq.com.au