

11-09-99 11am

Bob Cooper's

SEPTEMBER 15 1999

SatFACTS



MONTHLY

Reporting on "The World" of satellite television in the Pacific and Asia

IN THIS ISSUE

**Norfolk Island's
10m
Aurora Dish**

**Australian Law
Targets Pay-TV
Piracy**

**Sat Cruiser's
DSR-201P,
Strong SRT 170LT**

- ✓ Latest Programmer News
- ✓ Latest Hardware News
- ✓ Latest SPACE Pacific Reports
- ✓ Cable TV Connection

**Vol. 6 ♦ No. 61
Price Per Copy:
NZ\$9/A\$10/US\$7**



Paraclipse[®]



When quality, strength, and accuracy are your main requirements, **Paraclipse** antennas are your first choice.

Only **Paraclipse** offers such variety; four distinctly different series: the Truss-Ribbed Classic, the Courier Deliverable Eclipse, the Stretch Formed Hydro, the Commercial Patriot.

Every **Paraclipse** model sets the industry standard in its class, worldwide.

HYDRO
SERIES

ECLIPSE
SERIES

CLASSIC
SERIES

Distributed in Australia & the Pacific by

**SATECH Satellite
Communication
Technology Pty. Ltd.**

18/477 Warrigal Rd, Moorabbin
East, Victoria, Australia 3189
tel 61-3-9553-3399
fax 61-3-9553-3393

Paraclipse[®]
HIGH PERFORMANCE ANTENNAS

★ **MADE IN
AMERICA**

Paraclipse Inc.
2271 29th Avenue East, Columbus, Nebraska USA 68601
Telephone: (402) 563-3625 Fax: (402) 564-2109

SPACE PACIFIC REFERENCE MATERIALS

(updated September 15, 1999)

to help you do a better job, profitably

Some items in limited quantity (marked LtdQty); many have special SPACE member discounts

SPACE Pacific Report (# 9901, 9902, 9903, 9904)

The television programme, direct to you from digital master on E240 VHS tape, PAL format of course. Show 9901: "It is your signal, too" and "Fun and games with the spectrum analyser." Show 9902: "Feeds and LNBS" - understanding how products differ. And, "Mark Long's Thumbnail History of home satellite TV" featuring the real pioneers of the 70s and 80s! Show 9903: "Dish antenna critique," why some dishes work better than others, plus Mark Long on installing your own dish, and, Richard Brooks on PVRs. Show 9904: "Who buys DTH systems?" explores the marketplace, plus, "Understanding Tiny Parts" looks at connectors, line-amps and splitters. Four hours as currently running on KIBC, SPN - digital mastered to you for the exceptional price of \$55 including shipping and two bonus items - "Satellite Television (The Booklet)" featuring material by Sir Arthur C. Clarke, and, the infamous CMT satellite pencil-writer! (see order form, below). In stock, shipped within 72 hours. (No SPACE discount)

Shows 9905, 9906, 9907, 9908 & 9909

The television programme - the latest releases (even before they appear on KIBC!). As described above. Show 9905: Robin Colquhoun illustrates the Dr Overflow software for the Nokia; Show 9906: How the uplink works - possibly the best programme topic ever created. Show 9907: Part two of uplink. Show 9908: Instructor Mark Long's "Digital Basics." Show 9909: Mark Long's "Installation Basics" with emphasis on Ku service. Shows 9905, 6, 7, & 8 available October 5. \$60, no SPACE discount.

World Sat TV '96

If you are new to satellite TV, are not sure about the difference between the LNB and LNBF, or what vertical and horizontal means - this is the self-learning book for you. Written by Mark Long, it takes you from total novice to satellite expert in 13 well illustrated, carefully explained chapters. Originally written for Asia & Middle East, this 1996 version heavily discounted at \$15 (LtdQty); SPACE discount applies.

World Sat TV '92

Essentially the same book as World Sat TV '96 but released four-years earlier. All of the basic fundamentals are here, at a price that is too good to be true. Hey - the quantity is very limited (LtdQty) and we need to clear out the shelf space. \$10 and if you are a SPACE Member, it comes down 30% to \$7! Having a complete satellite TV reference book doesn't get any cheaper than this.

TB 9404 DTH Systems

Direct to Home: Satellite System Installation Techniques. Without question, the very best quick tutorial on what a home dish system is, how it works, where the problems develop. If you are new to the DTH field, buy this and commit it to memory. Very slight New Zealand bias, not enough to hurt its value world-wide. Prepared by Coop for an Asian DTH technology conference, LtdQty \$10 (SPACE discount).

TB 9405 SMATV Systems

Satellite to room - Commercial SMATV (Satellite) Dish Installations. The easy part is the satellite dish or dishes. The difficult challenge is getting all of those signals - including the terrestrials - balanced and into every room and each TV outlet at the proper level. If you plan to do multiple-outlet systems, start here with this Coop written tutorial. LtdQty and only \$10 per copy while they last! (SPACE discount)

Nelson Parabolic Manual

The Nelson Parabolic TVRO Manual. If you are the type of person who wants to build your own dish (up to 3.7m in size), or, you simply want to understand why some dishes work better than others, this step-by-step "how to build a dish" manual is the "Bible" of an industry. Nelson Ethier was a perfectionist and brilliant with hand tools. It shows here - the ultimate backyard project! Half original price at \$15, LtdQty, SPACE discount applies.

SPACE Pacific Order Form (also see SPECIAL PACKAGES on reverse side)

Please send the following:

SPACE Pacific Report - 9901-9904/ \$55 (no discount); Shows 9905-9908/ \$60 (no discount); Package deal - 9901-9908 (2 tapes)/ \$105 (no discount); World of Sat TV-'96/\$15; World Sat TV-'92/\$10; TB 9404 - DTH Systems/\$10; TB 9405 - SMATV Systems/\$10; Nelson Parabolic TVRO Manual/\$15. Total of order - \$_____ . If current

SPACE member, multiply by 0.7 (70%) and write discounted total here: \$_____

I wish to pay this by cheque (enclosed) VISA card Mastercard

Card number _____ expires ____/____

Ship to (name as it appears on card):

Company _____

Mailing address _____

Town/city _____

Your signature: _____

SPACE Pacific Terrestrial TV Reference Materials

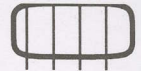
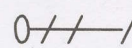
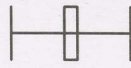
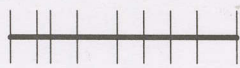

Each of these editions researched, created by "Coop" to help you solve tough aerial problems

TB 9301	Tech Bulletin 9301. Co-Channel & Antenna Phasing. How to grow a single antenna (Yagi, broadband antenna) into a complex array to greatly increase gain, sharpen receiving pattern to eliminate co (same) channel interference. Totally hands-on, very practical, up-to-date. Go from novice to professional!
TB 9302	Tech Bulletin 9302. Weak Signal Reception Techniques. If one cut-to-channel (Yagi) antenna won't do the job, will 2, 4 or 8??? How about 16? Stacking antennas, mating with carefully selected masthead amps, is an art. This explains how to do it for professional results up to 300 km from TV stations.
TB 9303	Tech Bulletin 9303. UHF - The Frontier. Using parabolic style antennas surfaced with low-cost poultry mesh, build UHF dishes up to 40 feet in size to extend UHF off-air reception out to 300 km. And - learn the tricks to "squirt" signals from a hilltop to a valley below using low-cost receiving equipment.
TB 9304	Tech Bulletin 9304. Beating Noise Interference & Combining Cross-Pole Signals. When TV and FM signals are weak, man-made interference from appliances, power lines can kill reception. Step-by-step instruction for identifying, locating, fixing noise sources + unique method of combining cross-pole TV signals.
TB 9305	Tech Bulletin 9305. Cable Television - Fact & Fiction. The story of how a cable TV system is designed, built, operated. The perfect "So this is how it works!" report. Who knows - you might even like the concept so well you take out a mortgage on your home and wire your town!
Lost Art	Lost Art of Rhombic Antennas -27 dB of gain VHF & UHF. Everything you need to know to build the most sensitive VHF-UHF receiving antenna ever created. Rhombics are used for virtually all long haul military circuits. Includes super-Rhombic LaPorte design. 300 km? A piece of cake!
40' Dishes	20 to 40' Poultry Mesh (Chicken Wire) Parabolics. Complete instructions to build UHF-TV off-air reception antenna system combines low cost reflector materials with Redwood or other durable "struts." 20 to 25 dB of gain, out to 300 km UHF reception. A backyard project with earnings potential.
Half-Bolics	World-Famous Frias Half-Bolic Reflector. Amazing design allows simultaneous reception over sizeable arc of transmission locations. City grade (80 dBuV) reception from distances of 280 km on VHF (45 MHz) through UHF (900 MHz). This is huge, but easily the best all-around deep-deep fringe antenna system.
Raw Video	SPRSCS '99. SPACE shot many hours of video during SPRSCS '99 to prepare for the (now available) 9901 - 9904 one-hour TV shows. In "Raw Video" you have everything shot, <u>before</u> editing, including material done by Robin Colquhoun for the Dr Overflow software explanation - still not edited into a TV show. 4 hours, PAL.

ORDER FORM - and special discount packages

Please send the following:

- TB 9301/\$10; TB 9302/\$10; TB 9303/\$10; TB 9304/\$10; TB 9305/\$10; Lost Art-Rhombic/\$20; 20-40' Dishes/\$20; Frias Half-Bolic/\$20 - or
 TB9301/9302/9303/9304/9305 - \$40 -or- Rhombic/ 20-40' Dishes/ Half Bolics - \$50 -or-
 TB9301/9302/9303/9304/9305 + Rhombic/20-40' Dishes/Half Bolics - \$80.

Video: Space Raw Video/\$35; SPACE Videos - 9901-9908 + Raw Video/**3 tapes** \$135.

Total of order - \$ _____; If current SPACE member, multiply total by 0.7 to obtain discount price (NOTE: No discount applies to Raw Video or SPACE Pacific Report) - new discount total \$ _____. I wish to pay this by Cheque (enclosed) VISA Mastercard

Card number _____ - _____ - _____ expires ____/____

Ship to (name as it appears on card)

Company _____

Mailing address _____

Town/city _____

your signature _____

Return to: SPACE Pacific, PO Box 30, Mangonui, Far North, New Zealand or fax to 64-9-406-1083

SatFACTS MONTHLY

ISSN 1174-0779

is published 12 times each year (on or about the 15th of each month) by Far North Cablevision, Ltd.

This publication is dedicated to the premise that as we enter the 21st century, ancient 20th century notions concerning borders and boundaries no longer define a person's horizon. In the air, all around you, are microwave signals carrying messages of entertainment, information and education.

These messages are available to anyone willing to install the appropriate receiving equipment and, where applicable, pay a monthly or annual fee to receive the content of these messages in the privacy of their own home. Welcome to the 21st century - a world without borders, a world without boundaries.

Editor/Publisher

Robert B. Cooper (ZL4AAA)

Office Manager

Gay V. Cooper (ZL1GG)

Reaching SatFACTS

Tel: 64-9-406-0651

Fax: 64-9-406-1083

Mail: PO Box 330

Mangonui, Far North

New Zealand

Email: Skyking@clear.net.nz

<http://www.satfacts.kwikkopy.co.nz>

Subscription Rates

Within NZ: \$60 p/y

Australia: AV-COMM Pty Ltd, PO Box

225, Balgowlah, NSW 2093

61-2-9949-7417

Elsewhere: US\$60 p/y

All copies sent via airmail fast post world-wide

ERRATA

SatFACTS Copyright 1999 by Robert B. Cooper; any form of copying is a violation of our international copyrights. Advertising rate sheet available upon request.

COOP'S COMMENT

This issue marks the 61st consecutive month that Gay and I have produced and mailed SatFACTS. There are thousands (and thousands) of eyes reading this issue - we had a few hundred with issue number one.

We come by this venture quite naturally having first launched a publication called "DXing Horizons" in January 1960. Over the ensuing decades there was TV Horizons (the first magazine anywhere in the world devoted to the cable television industry), Communication Horizons (professional two-way radio), CB Horizons (the world's first consumer magazine for CB radio - now that was a venture!), and VHF Horizons (for amateur radio operators).

In later years there was CADCO Monthly (a technical journal for cable TV engineers), CATJ - Community Antenna Television Journal, CSD (Coop's Satellite Digest, which launched the first home dish industry in 1979), CSD-2 (by 1982 the industry was large enough that we went to biweekly) - and others. CB Horizons grew to more than 50,000 subscribers in 18 months - pushing me first out of my spare bedroom publication creation area and then out of California to Oklahoma because we didn't have printers on the west coast capable of cranking out so many magazines each month. In between, several dozen books, the occasional (well, more than 2,000 before I lost count) articles for the likes of TV Guide, Wall Street Journal, and a list of semi-familiar electronic industry journals as long as this page. And TV shows.

My favourite magazine was Coop's Satellite Digest. We were very proactive, pretty much set the tone for the development of home dish systems between 1979 and 1987 and in the course of turning out issues that individually had as many printed pages as we run here all year long managed to make thousands of friends at every level of the industry, including (Sir) Arthur C. Clarke. Turning out SF would be more fun if we were to make any money doing this. Bryon Evans (Pacific Antennas) tells me, "If it were not for SatFACTS, there would not be any industry down here for home dishes." Garry Cratt (Av-Comm) asks me several times each year, "How long will you keep doing this and not make any money from it?" Leon Senior (Satech) and Peter Merrett (Sciteq) ask similar questions, concerned that one day I might wake up and ask myself the same question!

The answer is that I enjoy doing this, although Gay certainly could find better things to do with the 8-10 hours each day she spends watching over our subscriptions and record keeping. If I wasn't doing this (and keeping our tiny, neighbourhood cable TV system functioning), I would probably finally get around to finishing a couple of books which only see my attention once or twice a year now.

So here we are in the start of year six for a magazine that exists only because several thousand people spread through 55 countries want it badly enough to spend money for it. Not enough money to make it pay for us, barely enough to pay the cost of printing and mailing, in fact. And a couple of times each year - not even enough for that. We do this because it gives us some pleasure to provide information that would otherwise be impossible to find. And because, as Bryon Evans so aptly states, without SatFACTS there would be no home dish industry in the Pacific. For those firms who do advertise - you as a reader should show uncommon allegiance. For those firms who do not advertise - after 5 years of being here for them as well - you should perhaps remind them of the wisdom of Bryon Evans.

In Volume 6 ♦ Number 61

The ultimate antenna - 10m dish for Norfolk Aurora service -p. 6

Digital+Analogue+Positioner - Sat Cruiser DSR-201P -p. 15

Versatile Analogue Receivers at give-away pricing: Strong SRT-170LT -p. 20

Departments

Programmer/Programming Update -p.2; Hardware/Equipment Update -p. 4;

Cable Connection (testing LNB/LNBF products) - p. 22; SatFACTS Digital Watch -p. 24;

Supplemental Digital Data -p. 26; SatFACTS Analogue Watch -p. 27; With The Observers -p. 29;

At Sign-Off (Australian Legislation targets pirates) -p. 32

-ON THE COVER-

Charles Shaw on Norfolk Island with Laser Level inside 10m dish (p. 6).



September 15, 1999

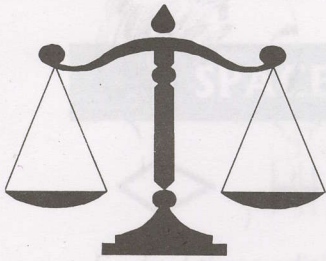

LETTERS

Good guys that we are ...

"Thank you very much for your assistance putting me in touch with someone who could help me solve a delicate technical problem. You said someone would call me and they did - spent nearly an hour on the telephone - one of the outstanding advantages of being a Member of SPACE!"

Brian Watson, Western Video Pty, Kings Meadow, Tasmania

People to people is what SPACE is all about - knowing who can help and arranging for that assistance. Those who do not belong to SPACE are missing out on a very important element of our industry - help when you need it from people who know the answers.

"I forgot to tell you on the telephone today - thank you for a great magazine, a true mine of information, very readable even for a non-algorithm head like myself!"

Claudio M. Paroli. RAI International Australia

"Just letting you know I managed to sell my Echostar receiver and positioner because of the listing on the SatFACTS Web site swap and trade section. Thanks for the great reader service!"

Elvin Slavik, Victoria

"You can remove my 'Wanted-Panasat 520' listing from the SatFACTS Web site - I have found one here in SA. This is a very nice service."

Tony Drexel, Free To Air Satellite Services

We do try - and between the wide reach of SatFACTS, Coop's Technology Digest, our Web Site and the weekly television programme, we believe most of the bases are covered. Next stop - a regular nightly call-in, talk-back radio show distributed by satellite to the Pacific and Asia. Is there someone out there with a few grand to spend to launch this next step?

Thai 5 service

"To answer David Leach's query (SF August 15), the Thai 5 service continues on Intelsat 702 (Ku) because they need to link from USA into Pacific. Moreover, no decision has been reached regarding the present test service on B3 (within the TRT bouquet) being available as a regular service."

Bill Richards, Adelaide

Which show on KIBC?

"I was watching the SPACE Pacific Report today at 1400 and it was #9902 - should have been 9903? Am I missing something or will KIBC show 9903 at a different time. Hey - I really enjoy this programme!"

Pietro Casoar, DigitalSat Communications

We do not have perfect communication with KIBC. They load their automatic tape servers Friday nights for the full weekend and sometimes there are mistakes. We've seen the "right" (as in as-scheduled) shows on Saturday and then a rerun of an earlier show on Sundays. Hang around - as we and they get the hang of this, it will get better.

PROGRAMMER PROGRAMMING PROMOTION

UPDATE

September 15, 1999

Norfolk issues. Although our emphasis is on technology, we should not lose sight of the human factors that ultimately dictate the ways technology is employed. Norfolk Islanders (p. 6) have their own IDD prefix (672), pay A\$1.50/min for calls to "mainland" Australia, \$1.99/min for calls to New Zealand. A local notes, "If Norfolk was really a part of Australia, we would have Telstra here long-lining the phone calls from their Paddington/Broadway cable terminal and would pay Australian country call charges. However, to maintain our 'independence' one has to pay a price." Pay-TV? \$44.95 per month because islanders purchase and install their own equipment which typically begins with a 2m dish. Charles Shaw, the electronics guy behind the 10m dish install, believes credit must be shared with Matt Bigg and Peter Ely - Bigg, a motor mechanic by trade and Ely, a fitter and turner, provided the perfect "balance" to Shaw. And after 23 years Shaw is departing Norfolk to return to the "mainland" in January. His business, home and a nice life style are available for someone willing to become the island's next electronics guru (email seashore@ni.net.nf, tel + +672-3-22789).

About time. First major modifications to Australian Copyright Law since 1968 introduced as proposed Bill to House of Representatives September 2, creates monetary fines and jail time for dealing in "circumvention devices" intended to get around pay-TV encryption routines. We analyse - p. 32.

Pacific Time's PAS-8 Ku transponders are variously reported throughout New Zealand, Australia, Pacific (such as New Caledonia); some at rather healthy signal levels (10 dB C/NR on 3m dish). While the three MCPC bouquets (12.286, 12.326, 12.366) are reported vertical, Steffen Holtz (Noumea) finds them on "same polarity as TARBS which is supposed to be horizontal." One New Zealand reporter found Cinemax movies in clear, others report the service loads but will not display programme channel numbers (varies between 8 and 10 per bouquet). The services are reported to be Viaccess CA, some purposefully FTA including - apparently - Barker Channel on 12.286 (VPID100, APID 101) and Global TV (VPID 200, APID 201). We need more people looking with a greater variety of IRDs - and reporting results. Yes, this is supposed to be "NE Asia Beam" but reports say PAS-8 Ku was damaged prior to launch so most anything is possible.

Wasted bandwidth. Those colour bar test patterns presently appearing within the CNBC/ex-NBC PAS-2 MPEG-2 MCPC bouquet. When NBC closed down, National Geographic replaced it. Now with National Geographic permanently moved to Star Asia, NBC apparently has no near or mid-term plans to place something useful on the programme channels previously occupied by programming. Perhaps we can talk them into running our SPACE Pacific Report there???

SATECH in NZ. Mathews Electronic Services (Auckland) is the newly appointed agency for products from distributor SATECH in Melbourne. This includes receivers, antennas, parts as well as service back up. Their telephone is 0800-777376, fax is 09-634-3019.

Steve Johnson, Franklin Aerial, Auckland area looking for NZ dealers who wish to share purchasing power for antennas; email steve-j@ihug.co.nz.

Solar outage time is upon us - just a reminder that as the sun approaches the equatorial crossing point, satellite services will be shutdown for several minutes per day (if your reception quits, run outside to check that the shadow from the prime focus feed is squarely in the centre of the dish - indicating the sun and the satellite are at the same elevation and azimuth from your location).

THE TRUTH IS HERE.....

HUMAX FI-CI

www.humax.co.kr/

Common Interface for VIACCESS(TM), Conax,
CryptoWorks(TM) Nagravision, Irdeto and more.
Humax CI is capable of interfacing CAMs of DVB
Common Interface Standard & F.T.A.

Humax IRD: \$699.00 (Aus. & Tax Incl.) Plus P & H
IRDETO CAM: \$115.00 (Aus. & Tax Incl.) Plus P & H

International Enquiries Welcome

SATSYSTEMS PTY LTD (ACN 081 755 722)

P.O. Box 2180, Fountain Gate, Victoria, Australia...3805

PH: +613 97965692 Fax: +613 97086478 Mobile: 0414 500 370 Email: tormey@ihug.com.au

Sales Agent For Humax in Conjunction with
R.G. Electronics P/L (Sole Importer for Humax)

Installer view

"To me, the hackers are a bloody nuisance. What percentage of viewers would pay-TV operators tolerate as freeloaders? I doubt the relatively small number out there would worry the programmers much. But with the publicity attached to the issue, it seems to be causing the programmers to run scared. And what is the incentive - around \$2 a day? Hardly worth the effort. If you do it yourself, you live in fear of being detected. If you purchase a reactivated smart card, how long will a hacked card operate? If it gets hit by an ECM, how long will the guy you bought it from replace the card? And after all of that, you settle down to watch this marvel and what you see is pretty ordinary and the repeats are legendary. Now the commercials are making their presence felt and the interruptions will eventually reach the level of FTA service. Yes, I earn a living from this - for the moment. But I very much doubt when it comes time to retire in say 15 years pay-TV will be still in existence."

CSS, New South Wales

We like the statement attributed to Sky NZ's John Fellet: "Pay television is really a bunch of very ordinary TV channels that you wouldn't pay 50 cents a month to have in your home individually - but for some reason you readily accept \$50 a month for the lot."

Optus mistake

"This morning a friend discovered the Aurora card in his UEC 642 will now allow access to GWN. Plus, all of the originally authorised services remain functional. He left it on for 8 hours, tried powering down and back up and it seems permanent. We do not live in a GWN authorised area. I wonder if an owner of a legitimate card, purchased at the time of buying the IRD, has any legal recourse against Optus if they destroy his card in a hit, mistakenly believing it to be a pirate card? That Optus makes mistakes is now clear to me. Once the IRD cards are out of warranty, Optus might randomly destroy Aurora smart cards allowing someone to profit from their replacement. I would hope that Optus will not be that heartless and dishonest."

A.I., Queensland

Seems like an accident to us; have others had new channels turned on without explanation by Optus? Of late, several SBS and even Central 7 have run FTA for periods of time to any IRD with a functioning card.

CNN status?

"I see in Digital Watch CNN, now on PAS-8, is temporary FTA. Two of my commercial sites with 1.8m dishes need to be upgraded to larger dishes - is it worth the effort? Would a better option be CNBC? And, there is a client with a 3.6m Orbitron that wants CMT. How can this be done?"

M.N., Alice Springs

CNN tells us their present FTA PAS-8 digital service will "one day" convert to CA, as virtually all other CNN feeds have done elsewhere in the world. CNBC says they "have no plans" for CA. CMT, once available to Australians on PAS-2 subscription, now refuses to authorise individual PAS-2 Australian clients citing their contracts with Austar, Foxtel and Optus as the reason. In fact, they simply don't want to mess with DTH.

HARDWARE EQUIPMENT PARTS

UPDATE

September 15, 1999

You work for yourself as an installer. And you think you have it rough. Think again. Comet Satellite and Cable (recently becoming a "Public" company), as the major contractor for Foxtel satellite has some very tough rules. For example? Well, Augat Snap 'N Seal connectors, a favourite of quality-conscious installers, are now forbidden. After September 1st - if you were caught using these "non-approved" fittings, this is "viewed as a breach of contract" and "will result in immediate termination of the contract agreement between the contractor and Comet." More? See synopsis p. 31 here.

The Nokia 9200 IRD is once again a "hot" item. Reason? This model works very well with the Dr Overflow (Internet available) software program that includes - if you know where to look for it - a "software blocker" that is reputed to stop ECM attacks on MOSC (modified original smart card) devices. Of course you have to know exactly what you are doing when loading the software, have to know where to get this unlisted software and know which version of Irdeto CAM to use for the "blocker" to work. We'll help you a tiny bit - CAM versions 2(X) and higher.

Humax IRDs. Or more specifically, Humax IRDs that will "do" PowerVu as well as Aurora's Irdeto CA. SF reported the "mess" created in the Australian-Turkish market (August 15) when a Melbourne firm (R.G. Electronics) began advertising using ethnic radio (and newspapers) that "*only our (Humax F1-CI) IRD is capable of providing TRT in a free-to-air format plus a planned (Irdeto CA) Turkish pay television service.*" Our Web site (<http://www.satfacts.kwikkopy.co.nz>) has updated this 'story' numerous times since mid-August. What seems to be missed by virtually everyone is that the Aurora Irdeto stream is NOT standard - *it is unique to Aurora*, a statement we have in writing from none other than Peter Iles, Irdeto's man in Australia. What this means is simply this - an Irdeto capable receiver must be custom programmed for Aurora and MUST be approved by Optus engineering before it can be sold for this purpose. The Humax IRD, as fine as it may be, at this point in time "fails the test" until it has the "stamp of approval" from Optus.

Grey market UEC IRDs. A letter over the signature of a UEC Middle Eastern executive made the rounds during late August, claiming that Multichoice (South Africa) sources for UEC660 IRDs being shipped into Australia would be shutdown. In fact, the letter appears to have been dictated in Australia with the apparent intention of "scaring" dealers away from purchasing Multichoice sourced IRDs from the western Australia supplier currently doing the importing. UEC-direct IRDs mysteriously dropped more than a hundred dollars in the face of Multichoice sourced IRDs according to reports - provided you purchase five or more at a time.

Telstra's "bold plan" to introduce satellite delivered "high speed Internet" to rural Australia is largely media hype. "Big Pond Advance powered by satellite" was announced with plenty of fanfare late in August but queries to Big Pond and other Telstra information sources have found nobody there who can explain the service, when it will be available, or how it will work. The system is simple enough - using Optus and PAS-8, a satellite dish connects to a satellite IRD PC card to deliver Internet at speeds up to 400 kbps. Getting to Big Pond to ask for an Internet connection will continue to be via existing terrestrial links. Telstra would like consumers to believe they are "first" in this technology - IHUG did it more than a year ago and several regional Internet providers now also offer this. As for new work for installers - it may be coming through firms such as Comet but don't expect a bonanza in new, profitable work here. *Soon.*

ADL[®]

BECAUSE PERFORMANCE IS ALWAYS YOUR FIRST PRIORITY

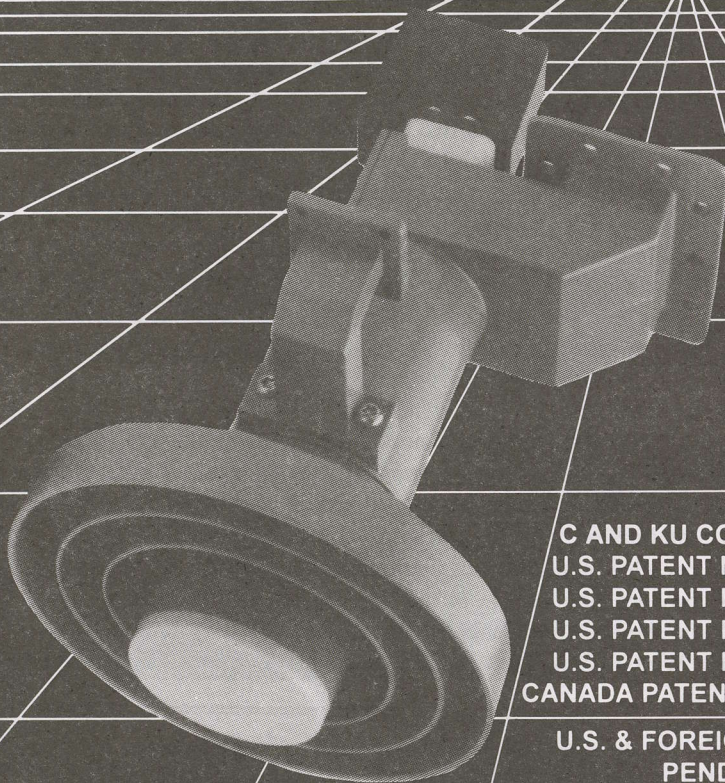

**RP3-CKU/ International
Adjustable Scalar Ring Feed
with Extended C Band**

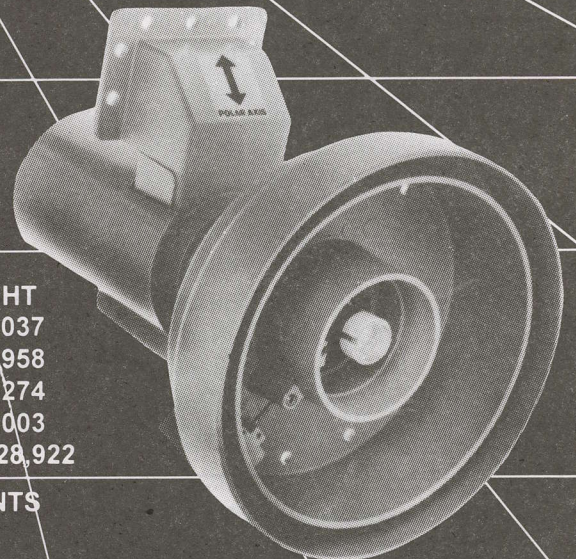

RPI-CKU Feed

**C AND KU CO-BORSIGHT
U.S. PATENT NO. 4,903,037
U.S. PATENT NO. 5,066,958
U.S. PATENT NO. 5,107,274
U.S. PATENT NO. 5,255,003
CANADA PATENT NO. 1,328,922**

**U.S. & FOREIGN PATENTS
PENDING**

ADL HYBRID MODING CIRCULAR POLARIZED INTELSAT FEEDS WITH EXCLUSIVE T.I. REJECTION



RP1-CP400



CP-300



CPOR-100

- C BAND LINEAR & CIRCULAR • C/KU LINEAR & CIRCULAR • KU 12 GHz FEEDS
- INTELSAT 4 GHz CIRCULAR • ARABSAT S BAND FEEDS

OPTIONAL: CO-BORSIGHT S BAND

2216 AGATE COURT, UNIT B, SIMI VALLEY, CALIFORNIA 93065 • (805) 526-5249 • FAX (805) 584-0634

NEW ADL Web site - www.adlfeed.com

Would you do this for 2,000 people???

The 10 Metre Antenna Challenge for Norfolk Island

Suppose your immediate *family* had around 2,000 people - cousins, second cousins, in-laws and the like. Moreover, suppose you all lived in a tightly confined area - like a large ranch - that measured 4 kilometres on one side and 9 on the other. Inside "the ranch" someone was responsible for making bread, someone else did the fishing, another tended a diesel generator to produce electricity, while yet another ran the school to teach the children. And a handful of "elders" from the family sat down every month or two for a day to discuss common problems and to search for a "democratic" way to resolve these problems.

Now suppose your "family" was very loosely related to some distant cousins who lived nearly a thousand miles away. And these distant cousins every now and again would try to convince you that you would be happier if you let them run your family affairs.

Norfolk Island sits in the Pacific east of Brisbane, and north of Auckland (NZ). In fact, Norfolk is only 450 miles from New Zealand. Within your 2,000 member family there are approximately 200 who come from the New Zealand "branch" of the clan, another 1,000 who have two or more generation

ties to Norfolk itself and the balance are recent arrivals largely from Australia and New Zealand, in that order.

Norfolk governs itself and residents have resisted attempts by Australia to hand over management of their affairs to Canberra for going on two centuries. It has been traditional for Norfolk to "hand back to Canberra" any aspect of day to day regulation which would cost Norfolk excessive amounts of money. For example - why set up a procedure and administration to process broadcasting licenses? There are a few "hams," a couple of transmitters at the Norfolk airport, and a few public broadcast transmitters. Creating an official government office to oversee such limited activity would cost more than the services would be worth (car registration, for example, costs \$95 and insurance is optional). So Norfolk, widely known for being populated by common-sense people, said, "No thank you - *Canberra can do that.*" And this has worked quite well, although in recent years as the number of satellite-fed broadcast transmitters has grown, Norfolk has been less conscientious about actually "asking" Canberra for a broadcasting license *in advance* of placing a new transmitter on the air. And Canberra has changed their attitude as well - "Well, if you don't see the wisdom of *asking* for a license

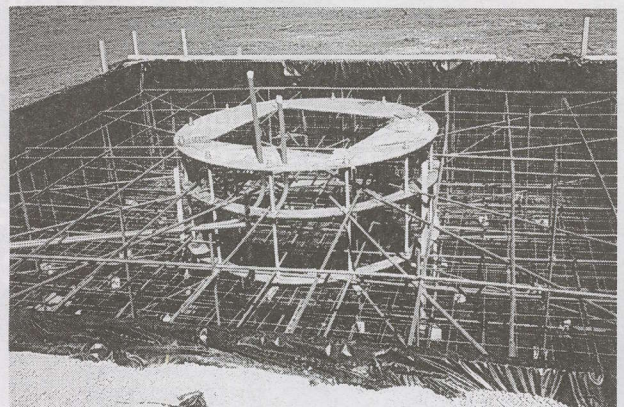
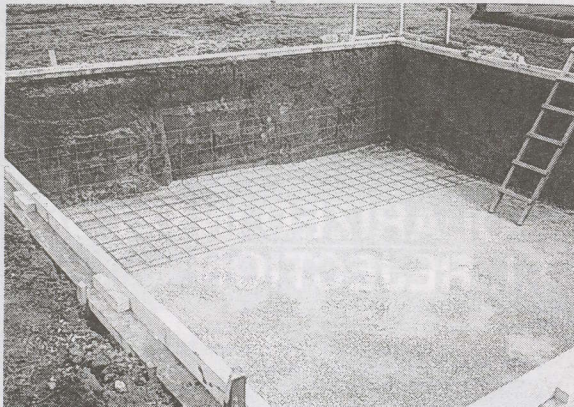

First you start with a hole in the ground (6m x 6m x 1.5m). Then you fill it up with steel to re-enforce the concrete. And round up everyone you can find to help with mixing and pouring more than 400 bags of cement. Then you allow the slab to set for a couple of weeks while tackling the antenna portion!

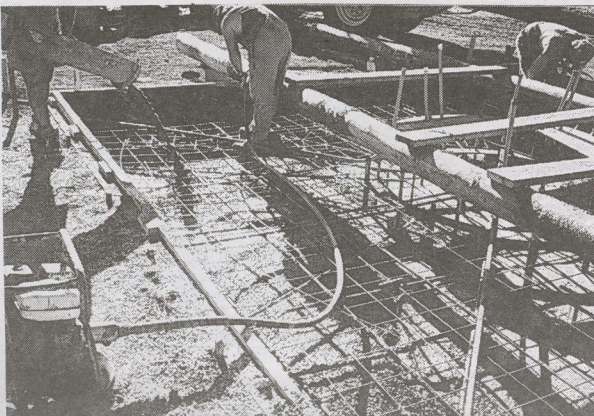

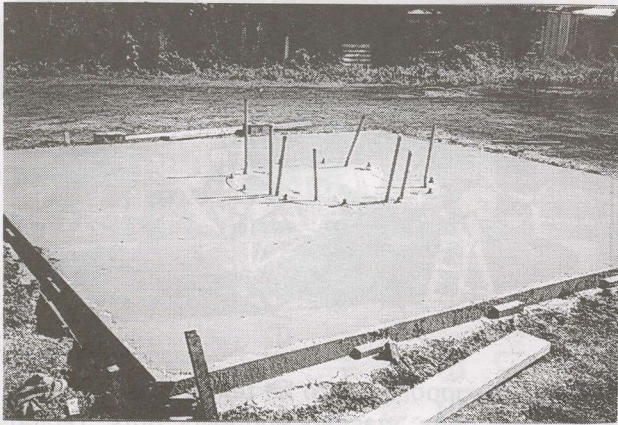

The bolts to hold the dish down were L-shaped, a metre in length. Conduits for power, coax and earthing conductors were buried. The base was bolted down, the motorised turret lifted and bolted into place. From 75 feet above ground, the "bosun's chair" view shows the mount ready for the reflector. A 1.8 tonne (concrete) counterweight, poured when the base was poured, was slid into position and bolted up.

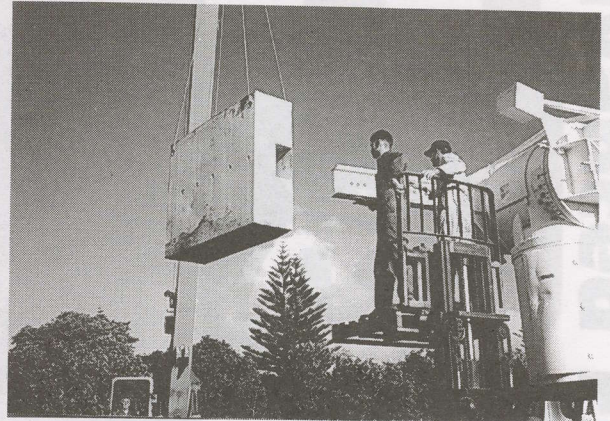
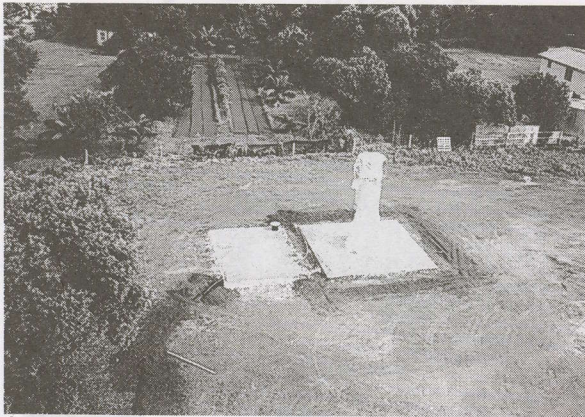
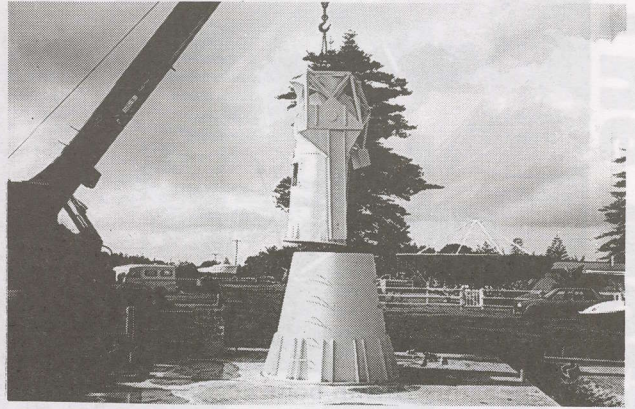

before turning on the new transmitter, perhaps you could advise us what you have done after the fact - *just so our records are complete here???*"

Into this "Live Free or Die" mindset of Norfolk has come television. While some very small communities have spent a great deal of money (per head of population) to generate local television, Norfolk saw no real reason to go down that road. Initially, television was not very important to their lifestyle, and if a few people wanted it - fine, let them have it. "Just don't tax the rest of us so that minority can have the damned box in their homes" was a popular view in the early 80s. A tiny handful of "enthusiasts" installed sizeable fringe area terrestrial TV aerials and imported sensitive receivers as early as 1960, content to have the snatch of long distance reception that always occurs each summer over the South Pacific. "Most of our reception - when there was any - came from South Island (New Zealand)" recalls Dale Petersen, who worked on Norfolk as a Chemist and maintained aircraft electronics at the

time. "We had a system of notifying neighbours when it happened and in minutes our living room filled up with people who sat there glued to the screen until the freak reception faded away. Sometimes it lasted for a few minutes, sometimes for days on end."

Alas, "DX" reception was hardly a substitute for full time quality TV and so in 1986, as Aussat created B-MAC relay of (initially) ABC and later SBS and regional services, Norfolk graduated to the live TV world. There were two possible ways to do this - each home would install their own dish and electronics (and in fact around 40 early birds did just this), or one common commercial grade dish followed by an appropriate low power transmitter to cover the 36 square kilometres of ground. A 3m dish, B-MAC receiver and 15 watt (peak pedestal power) transmitter on Australian channel 7 (182.25 MHz, vertical) made up the first serious service. Later SBS would be added (196.25, 25 watts peak sync) and eventually what we today call Central 7 shared time with SBS.

What - and where? - is Norfolk???

With 36 square kilometres of landmass, located at 29.05S and 167.59E, Norfolk is often described as an "Overseas Australian Territory." In fact, while Norfolk citizens may hold Australian passports, it is neither automatic nor mandatory. A (local) House of Assembly adopts laws they wish - in the absence of local law, Australian law is generally (but not always) followed. 2,000 people live on Norfolk, visitors may stay up to 30 days, anyone coming or going from any point goes through Customs and Immigration - including Australians. Norfolk has no income tax, residents pay a health care levy, 10% or more duty on imports.

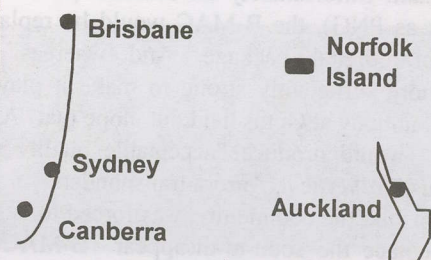

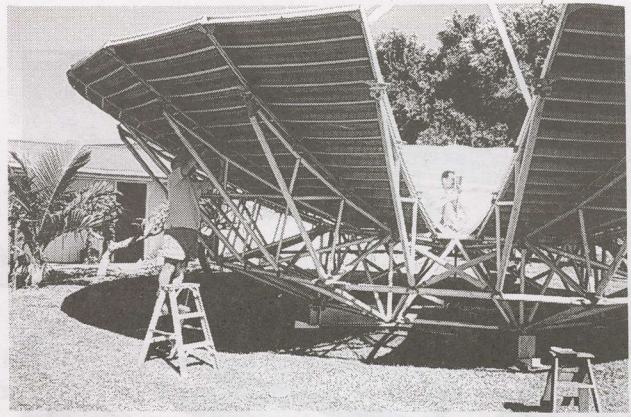
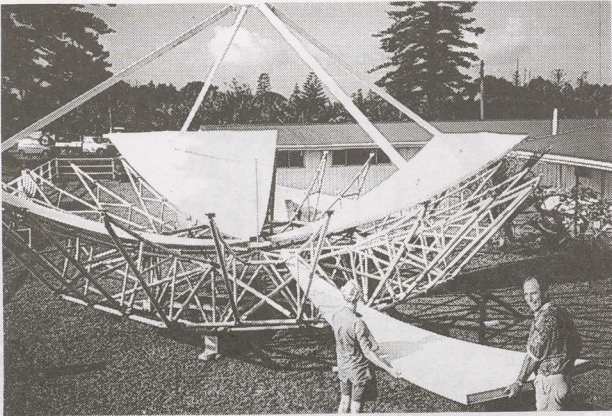

Four postholes with bolts concreted into position allowed the dish support ring to be temporarily "fixed" during assembly. Frame trusses were assembled using new stainless bolts, washers and nyloc nuts. Tedious hours - days were spent getting the frame level using a laser level. To preserve "level," wooden wedges were placed under each arm on the cross, assembling the dish in opposite segments to preserve balance. Rough levelling was followed by theodolite precision measurements. Shaw: "A week before I had never seen a theodolite up close; a week later, I was the island expert and had relearned high school trigonometry."

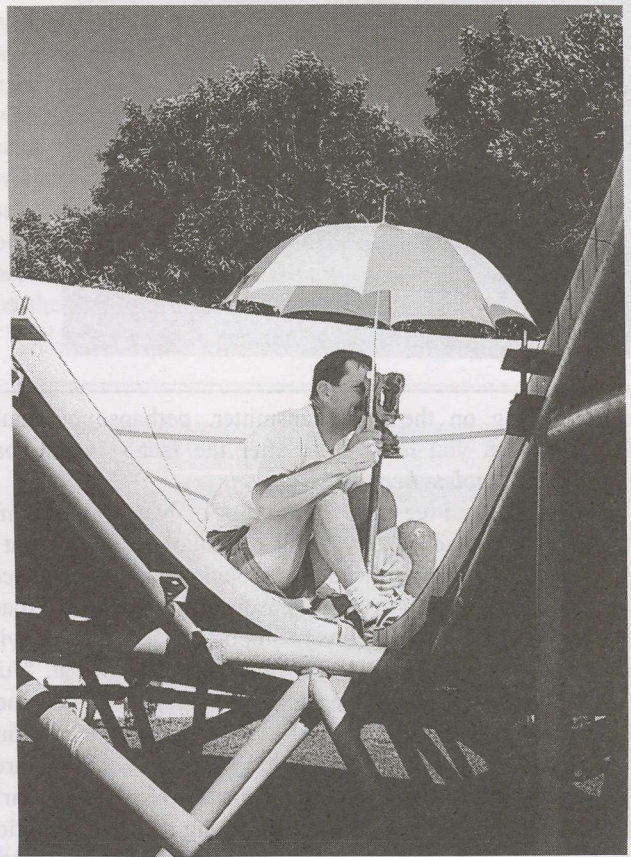

More would follow. And for as long as the "SE Beam" B-MAC services operated, service was acceptable if not brilliant. Unfortunately for Norfolk (and other offshore areas such as PNG), the B-MAC would be replaced with the new Aurora digital package. And whereas B-MAC sprayed offshore sufficiently strong to make it play on a 3m quality dish, nobody at Optus held out hope that "Any reasonable size dish" would produce "acceptable quality service" from the Optus B1, vertical, Aurora transponders.

Norfolk, the community, was forced to begin a serious effort to replace the soon-to-disappear B-MAC services early in 1999. Initial optimism that the transition to digital would be no

more complicated than replacing B-MAC receivers with appropriate digital IRDs would be dashed in April as tests for the Aurora services revealed no measurable signal on a 3m dish. Charles Shaw, handed the responsibility of making the transfer, reflects, "We were optimistic that perhaps a somewhat larger dish - perhaps 5 metre - would be required. We were not prepared, locally, for the necessity to jump all of the way to 10 metres!"

Indeed, even 10 metres would prove to be on the light side. Because Norfolk Islanders treasure their "independent status," and have learned over the decades that each time they accept some level of "assistance" from Australia, there is new erosion on their independent status, they were determined to do the job on their own. A 10 metre dish, ex-USA, ex-C-band, ex- a very

The Most Advanced Free To Air Digital Satellite Receiver

D7-MediaStar

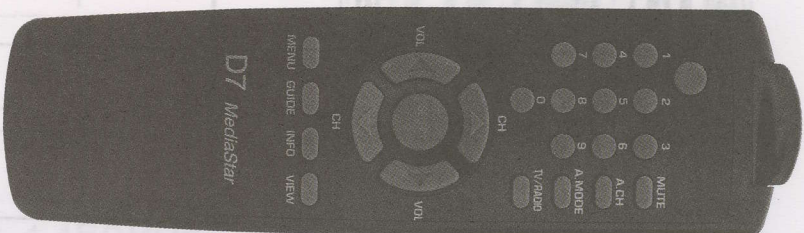
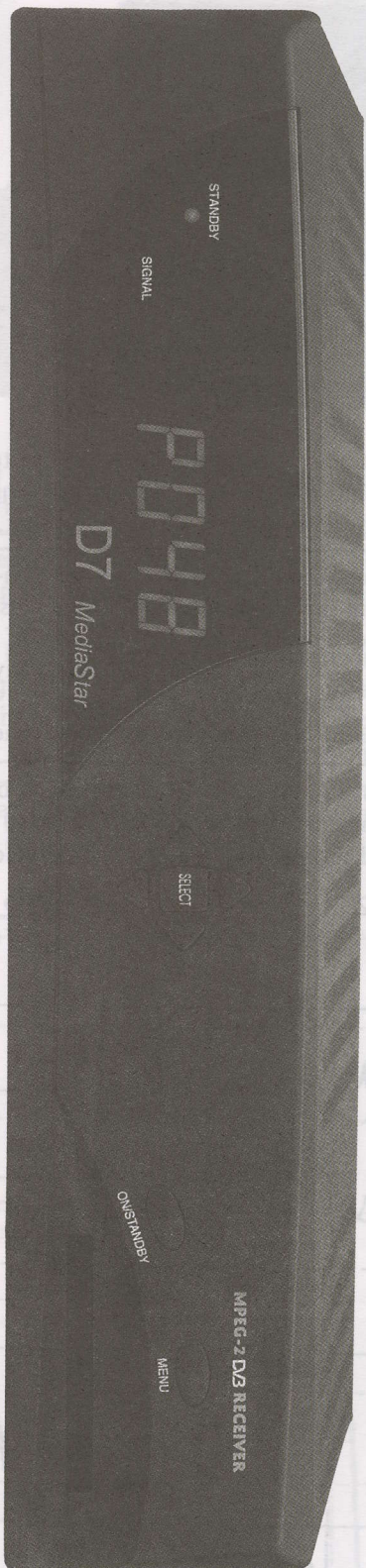

- MCPC/SCPC 2-36 Msym
- Direct channel selection from channel list
- Channel Edit menu Delete, Skip, ON.
- Fast response when changing channels
- No channel over-write
- 200 Video 100 Audio channels
- Automatic search and download
- 22 KHz switch
- PID Menu
- NTSC/PAL Auto switching NO NTSC Glitch
- NTSC converted to PAL-60Hz Free Option
- Audio L, R, Stereo selectable via remote control
- RF Modulator PAL-G, VCR/TV Scarts, RCA Audio/Video, SVHS outputs.
- 90-265VAC-50-60Hz power supply
- Low threshold performance



MediaStar Communications International
24 Bosci Road
Ingleburn NSW 2565 Australia

E-mail opac@bigpond.com
Tel + +61 2 9618 5777
Fax + +61 2 9618 5077

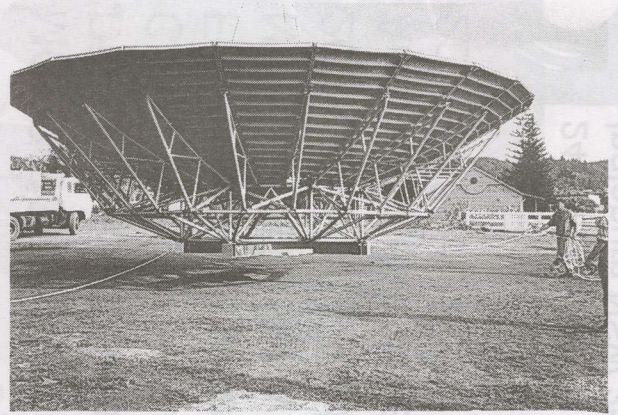
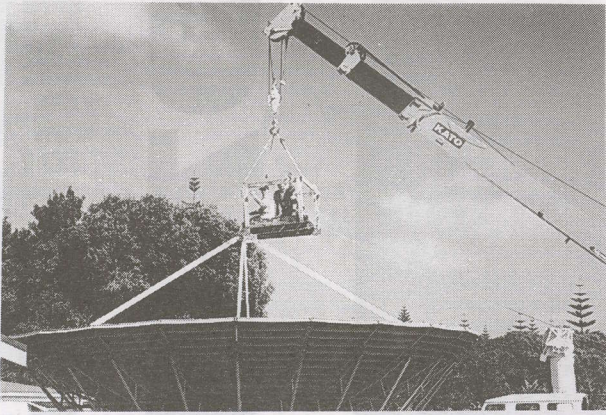

The dish focal point was initially "calculated" and would turn out to be a "soft focus" with around 1" of play in all directions. Optimism said there would be tons of signal - so the dish was installed in two hits while the crane moved one time (first to a pallet, then to the mount and stand).

cold climate (the heating arrangement to melt snow from the panels was a clue!) was located in storage in Australia. There had been some damage at some point between its removal from USA service and its arrival on Norfolk - three misshapen panels that required very tedious "panel beating" to bring back to even C-band perfection. Funds for the dish were generated

on-island; so too funding for the new electronics and installation of the huge antenna. For example, 54 cubic yards of concrete for the base - a major construction project anywhere, almost too much for a tiny island community.

Shaw was hopefully optimistic. "We had a limited budget, I knew this was a C-band rated dish and having inspected it

Ooops. Not so good. Optus B3, vertical, T3 (12.407) is barely discernible in the noise; T5 (12.532) and T6 (12.594) are below digital threshold while T8 (12.720) just nudges past 8 dB of signal reference noise.

Note date and time - May 27 and 3.40PM local time. A dark day for the project.

MKR: 1418.0MHz - 56.33dBm W: A
 RL: - 47.8dBm 2dB/ AT0dB ST 30s D: PK

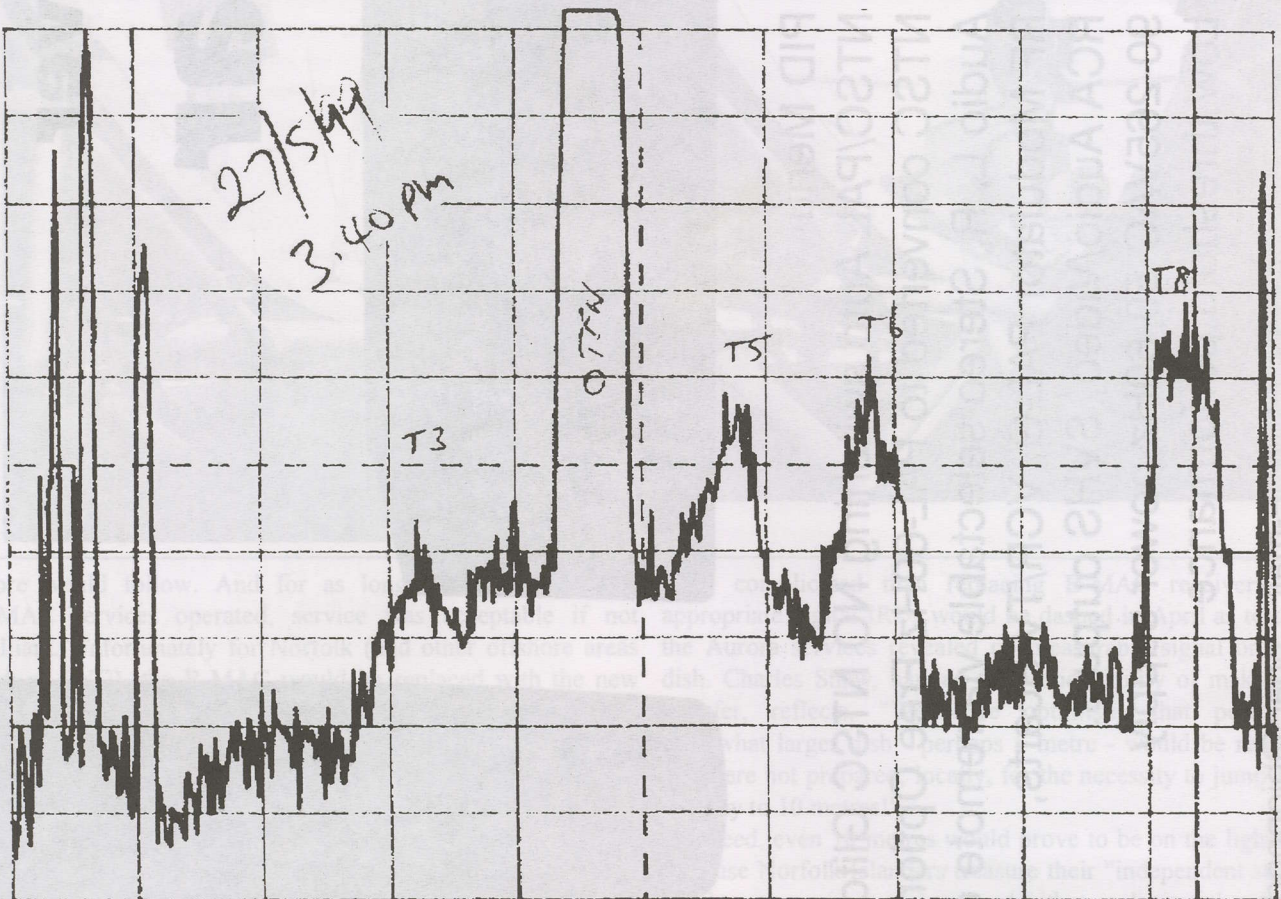

STF: 950MHz SOF: 1450MHz RB300kHz VB

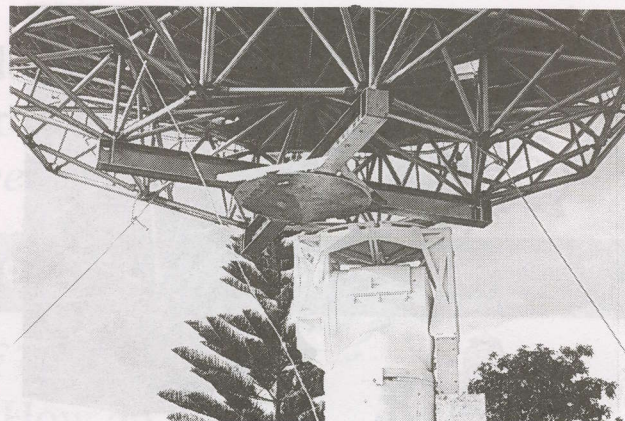
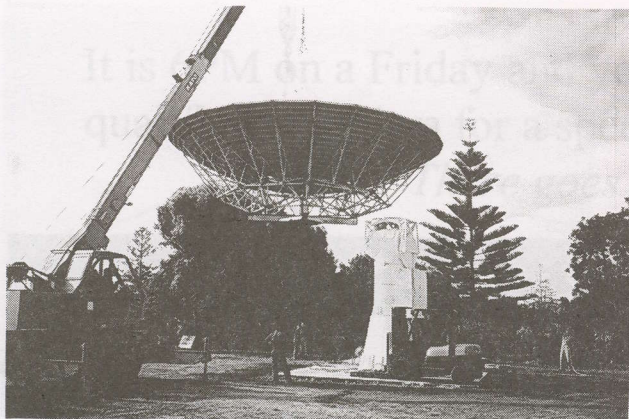

Lift to mount and a close up photo showing the heavy duty aluminium cruciform support as it was manoeuvred into position for the bolts.

prior to purchase, knew we had some very serious challenges to get it operational on Ku-band." At some point during the project virtually every member of the island "family" was touched by the effort. "The Administration Works Depot boys excavated the 6m x 6m x 1.5m hole for the base. It took more than 400 bags of cement, a celebratory fish-fry and cartons of beer to get the base installed!"

As the photos here depict, from hole in the ground to digital pictures was a journey of many steps. Some would be retraced and repeated.

There are not that many ten metre dishes in the world, seldom do they land on an island of 2,000 people and be wholly dependent upon local skills to make operational. This one was. Charles Shaw, an Australian by birth with 23 years

Looking better. May 31, 12.10PM. T3 is now at threshold level, T5 and T6 are comfortably 3 dB above threshold but now T8 has gone into a noise-dive and is straddling threshold for a 642 or 660 IRD.

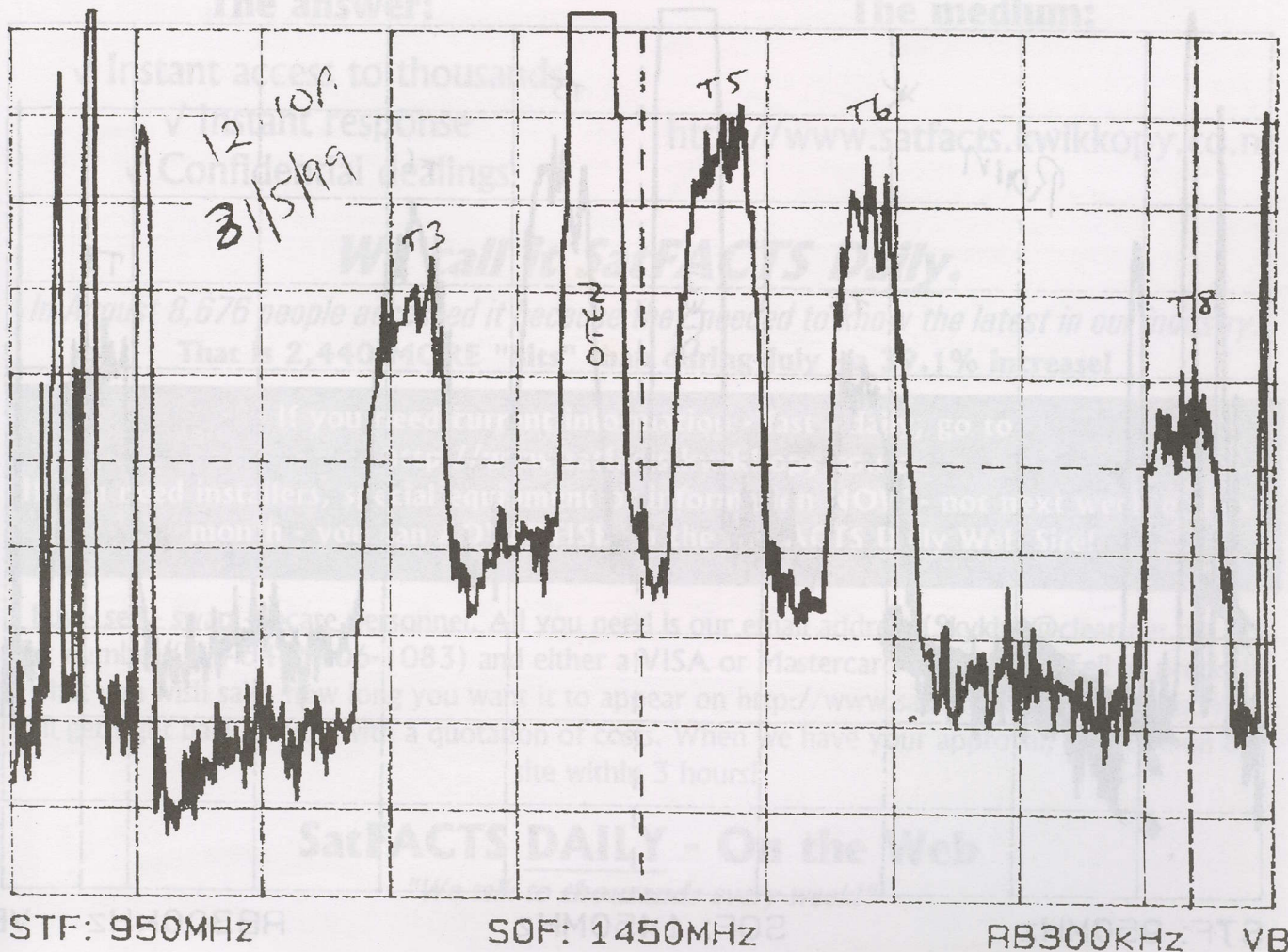

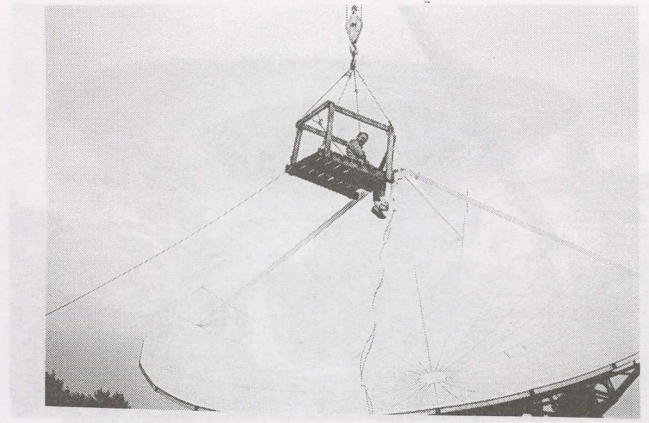
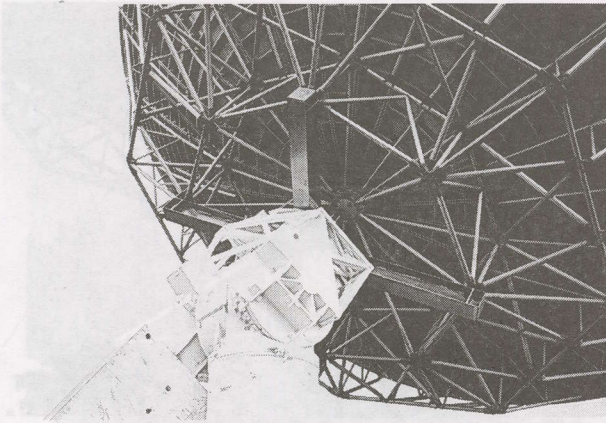

Pointed at B3 - the 10m has an elevation angle of approximately 54 degrees. On a dish this large, you don't "eyeball" the feed position or alignment! Right, feed testing on aerial pallet "bosun's chair."

on Norfolk, has been responsible for maintaining virtually all of the communication and high tech equipment for the island. "The locals say no matter how long a mainlander lives here, he becomes an islander in the same way a cat becomes a dog." The largest dish previously on Norfolk was 4.5m in size. Shaw expected a learning experience, but not quite what he got.

"Unfortunately, after initial tests, we knew there were problems. So the dish came off the mount and back to the

concrete supports. Now I found the centre hub needed to be rotated slightly. We missed this the first time around, mistakenly assuming the panels and frame would pull it to the correct angle (a trap for young players). It was a pity our 'friend' from Comtech had not alerted us to this possibility."

The dish gearing was designed for C-band adjustments; Ku wavelengths are one-third the size of C and when fine tweaking the dish for Aurora it was a bit like trying to fit a 1mm screwdriver into a 0.5mm hole that kept moving around

Effects of rain. May 28, 6.53AM and raining. T3 has headed down. T5 and T6 are down slightly while T8 is doing a tango with the UEC IRD's threshold point. "The signals float around, constantly, rain or shine."

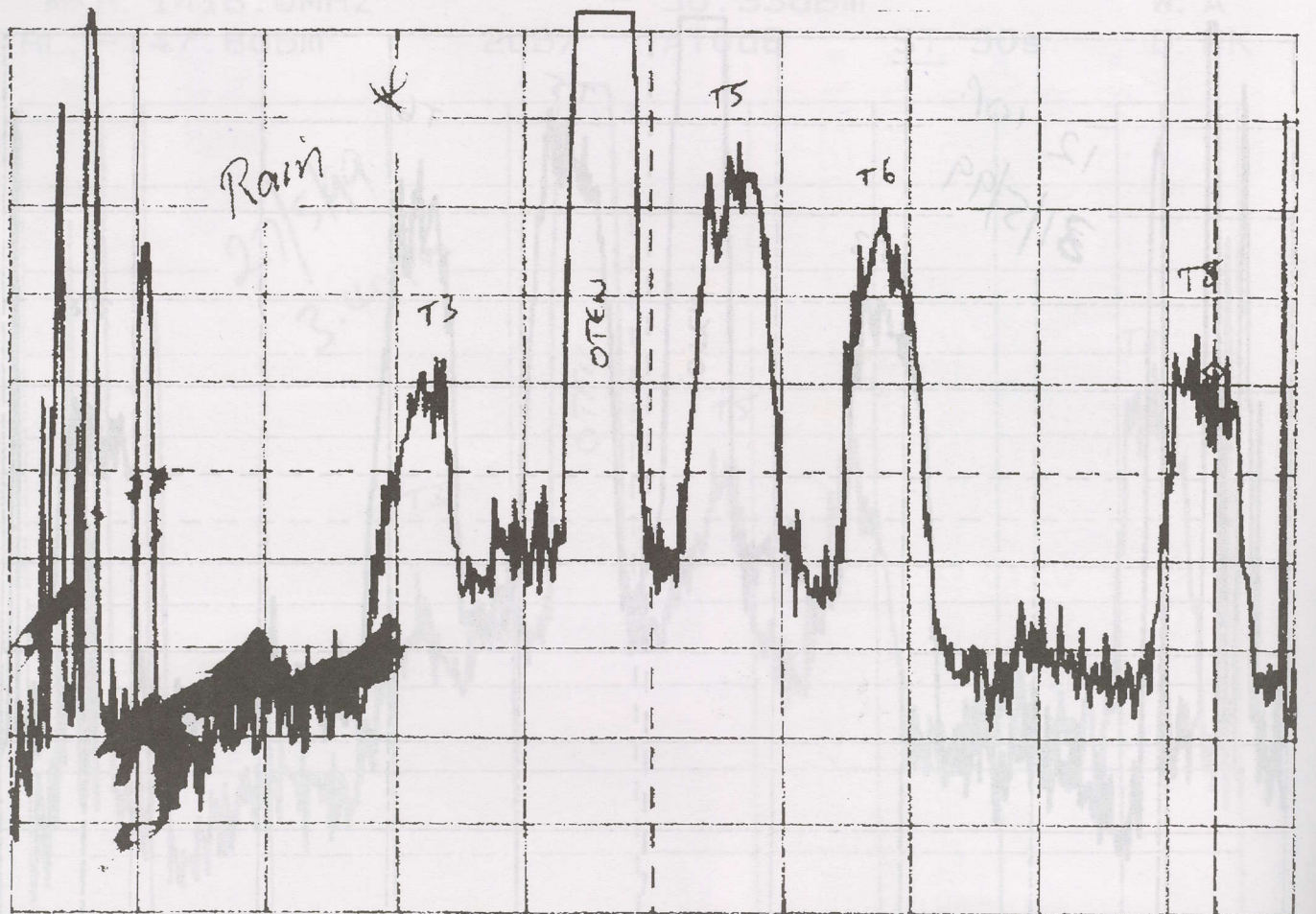

STF: 950MHz

SOF: 1450MHz

RB300kHz

VB

It is 6PM on a Friday and you suddenly need 20 qualified installers for a special project by 8AM Monday. *There goes the weekend.*

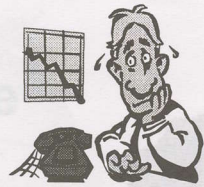

And perhaps - one heck of a good contract.

Two totally unexpected pallets of TRT capable receivers just arrived at the airport. How do you get the best price for them in the shortest period of time?



Perhaps you could look up "*Turkish Restaurants*" in the yellow pages?

You have been given 24 hours to locate a D9234 or equivalent *authorised* for WIN and GWN. And you don't know a single person in Western Australia!

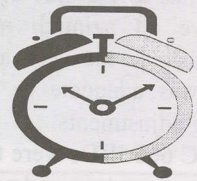

And Scientific Atlanta says, "You are on WHAT island in the Pacific???"

The answer:

- ✓ Instant access to thousands
- ✓ Instant response
- ✓ Confidential dealings

The medium:

<http://www.satfacts.kwikkopy.co.nz>

We call it SatFACTS Daily.

In August 8,676 people accessed it because they needed to know the latest in our industry. That is 2,440 MORE "hits" than during July - a 39.1% increase!

If you need current information - fast - daily, go to
<http://www.satfacts.kwikkopy.co.nz>

If you need installers, special equipment or information NOW - not next week or next month - you can ADVERTISE on the SatFACTS Daily Web Site!

Buy - sell - swap - locate personnel. All you need is our email address (Skyking@clear.net.nz) or fax number (+ +64-9-406-1083) and either a VISA or Mastercard credit card. Tell us precisely what you wish said, how long you want it to appear on <http://www.satfacts.kwikkopy.co.nz>. We will get right back to you with a quotation of costs. When we have your approval, it will be on our site within 3 hours!

SatFACTS DAILY - On the Web

*"We talk to **thousands** every week!"*

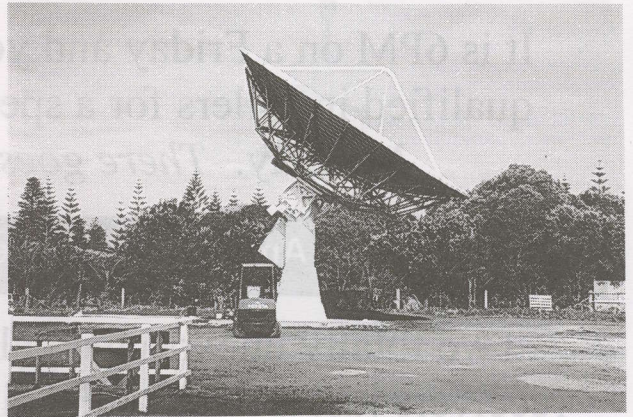
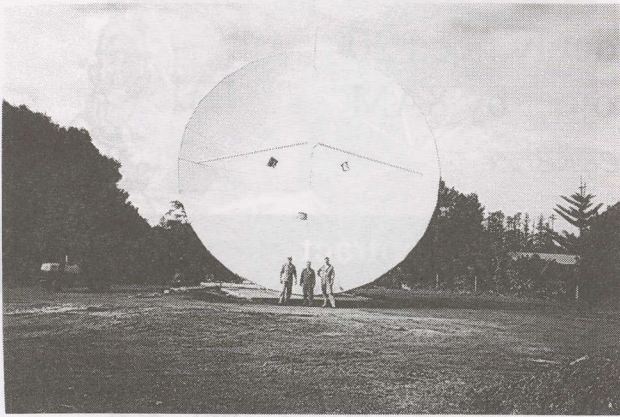

How big is 10m plus mount? Matt Bigg (who is not, here), Peter Ely and Charles Shaw with the antenna that connects Norfolk to the world. Finished product in front of radio station building. Alas, down it would come.

erratically. Shaw and company retrofitted a threaded rod and lock nuts to the side of the C-band adjustments. This helped remove all azimuth movement caused by the wind and backlash. In the vertical adjustment plane, the weight of the dish was adequate to hold the antenna steady during fine tuning adjustments.

UEC 660 IRDs were the final choice (642s hang when there is a power outage and come back on 12.407 whereas 12.720 is the Aurora channel of interest to Norfolk). The LNB is a CalAmp 0.7 dB and tests for the "best" feedhorn ended with selection of an Andrew feed which Shaw modified by cutting

off the scalar ring, replacing with a CalAmp prime focus adjustable front piece.

For Shaw, the 10 metre dish is a capper on his two+ decades on Norfolk; he plans a permanent return to "mainland" in January. He will be leaving behind four channels of terrestrial TV, 3 FM radio (+ one AM) and a massive steel and concrete monument to man's ingenuity. And the hope that when Optus C1 becomes operational in a few years, Norfolk will end up with some signal margin it does not now enjoy! Oh yes - Shaw is looking for a replacement to take over his business there. No 10m dish experience required! (see page 2, here)

The variations in Optus B3 - at Norfolk Island (averaged over 24 hour day)

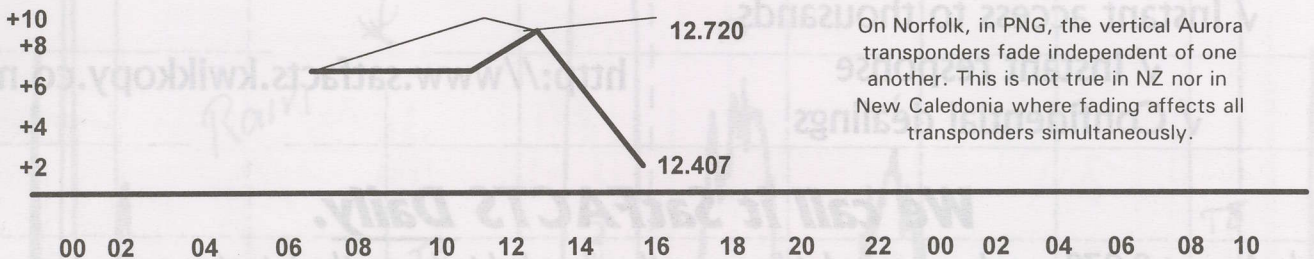

On Norfolk, in PNG, the vertical Aurora transponders fade independent of one another. This is not true in NZ nor in New Caledonia where fading affects all transponders simultaneously.

The variations in Optus B3 - North Island, New Zealand (averaged over 24 hours)

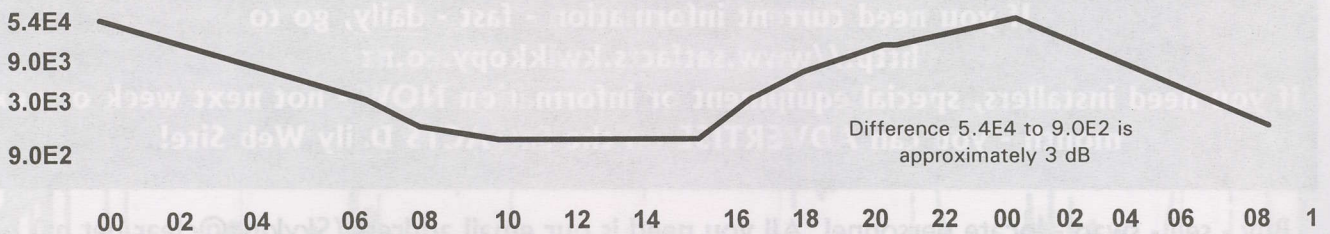

Difference 5.4E4 to 9.0E2 is approximately 3 dB

small, medium and LARGE C and Ku antennas in stock!

Transmit and receive antennas from 1.2m to 13m (Intelsat Standard B). Linear and circular feeds (AsiaSat, Palapa, JcSat, Rimsat, PanAmSat, Intelsat and more) for transmit and receive-only applications. Receive and transmit electronics including inclined orbit tracking equipment with motor drives for elevation and azimuth to 50 tons. Complete system design, fabrication, installation + proof of performance.

P
A
C
I
F
I
C



A
N
T
E
N
N
A
S

Limited

Sat Cruiser Digital + Analogue + Positioner Does it all



SatFACTS one year ago listed the Sat Cruiser 101 IRD as an FTA IRD capable of NTSC and PAL reception. During the ensuing 12 months a number of newer models have come into the Pacific under the Sat Cruiser / Skyvision Australia banner. The DSR-201P is the latest, a top end product that attempts to do everything in one container: PowerVu + FTA digital, low threshold and normal analogue, and dish positioning with a heavy duty actuator power supply and controller circuit. Sat Cruiser is a Skyvision Australia (the distributor) name, doubtless very similar or the same unit(s) appear elsewhere in the world (it is manufactured in Korea).

The danger with so many functions inside of a single software program is that operation becomes too complex for the "average" user. The challenge is to preserve a wide range of user functions without making access to the functions so cumbersome that only a "select few" can navigate the software. And there is a second danger - with any complex software program, it becomes increasingly more difficult to ensure that operational glitches do not foul up the functions. The Sat Cruiser 201P is at least a second generation down the road on both counts. It is very good, but not perfect.

This is a do-everything satellite signal receiving system for access to virtually every commonly used digital and analogue transmission format you are likely to encounter. Yes, that

includes the proprietary SA PowerVu system in its typical NTSC format.

If you have had experience with the "junior" member of this family - the DSR-101, the 201P will seem familiar. The graphics are virtually identical, although more inclusive (with the addition of an analogue receiving ability and motor controller for the dish actuator). Some functions are not clearly explained in the manual - for example, it is possible to enter only the (digital) transponder frequency and the receiver will search and identify the symbol rate and FEC. With a voltage switching LNB, the receiver will even identify the correct polarity. Then the "Edit TV List" sub-menu will get you to an on screen display of the parameters found. For the more difficult to load services (such as KIBC), PID/PCR numbers can be entered. For channels found automatically, a sub-menu will display the VPID, APID and PCR numbers - handy for passing along to others who need this information but who have less complete IRDs. Teletext is built-in (and works very well, including on the newly activated AsiaSat 2 Chinese services) and does not require a teletext-capable TV set.

Our impressions. The IRD has state-of-the art sensitivity on analogue, the threshold extension works as well as any we have tested. On digital, it runs circles around an SA D9223 and by measurement is as good as any we have tested for FECs

Rear deck includes SCART, baseband video and audio, 0-12V switching, L-band input and thruput, RS-232C fitting (handy for downloading newest software), modulator output and terrestrial antenna input, actuator connections for the motor drive.

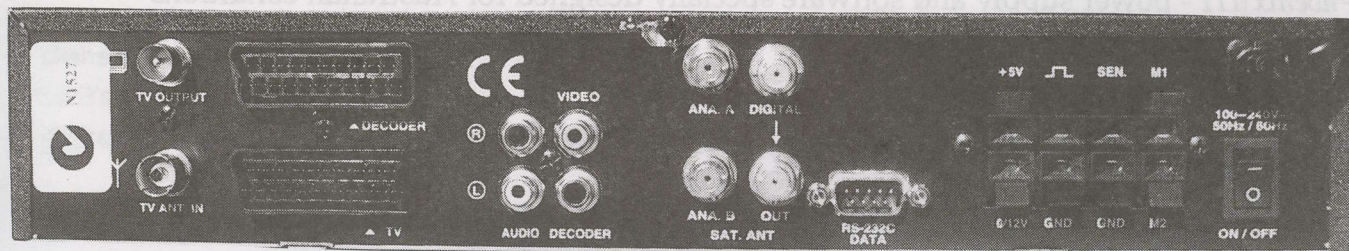

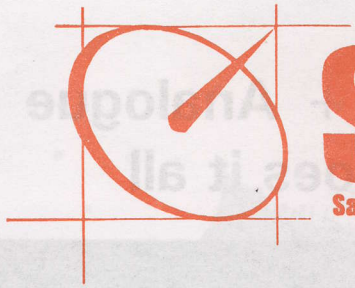

SATECH

Satellite Communication Technology Pty. Ltd.



THE NEW PHOENIX 333 with new software

Phoenix 333 - as quoted in November issue of SatFACTS " If we were forced to make a decision between owing any digital and any analogue receiver we would decide on owing the Phoenix 333"

- 3 in 1 Digital-Analogue-Positioner
- High Sensitivity on Digital
- Low Threshold on Analogue
- Heavy Duty Power Supply for Positioner



THE NEW PHOENIX 111 " REVOLUTIONARY IN COST AND PERFORMANCE "

Phoenix 111 - power supply and software specially designed for Australian conditions

- Digital
- High Sensitivity Loop through Tuner
- Built Digital NTSC to PAL Converter
- Heavy Duty Power Supply

Sole distributor for Phoenix Worldwide

SATECH

Satellite Communication Technology Pty. Ltd.

Head Office: 6/477 Warrigal Road Moorabbin East Victoria Australia 3189 Ph: 61 3 9553 3399 Fax: 61 3 9553 3393



SATECH Distributors for the full range of CALAMP

CABLES

Times Fibre & Comscope

huge range of RG6 & RG11

- dual
- quad
- flooded
- messengered

also 5 core tracking system cable
(available by reel or per meter)

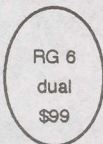

- CALAMP C band 25k voltage switching LNBF
- CALAMP KU band 1db prime focus voltage switching LNBF
- CALAMP KU band 1 db off-set voltage switching LNBF
- CALAMP C band digi-ready phase locked loop 25k LNB
- CALAMP C band mini-mag 17k LNB
- CALAMP C band mini-mag digi extended 20k LNB
- CALAMP KU band 0.8 db LNB
- CALAMP KU band 1db high stability LNB
- CALAMP C band extended professional II low phase 20k
- CALAMP MMDS integrated antenna

also available cyclone 2.3m mesh dish

- | | | |
|-----------------|----------|----------------|
| easy to install | reilable | cost effective |
|-----------------|----------|----------------|

CHECK OUT OUR WEB PAGE ON

www.satech.com.au or email to us at satellite@satech.com.au

One Stop Shop

- receivers
- dishes
- cables
- fly leads
- wallplates
- feedhorns
- Lns
- tools
- tape
- poles
- decktite

SATECH
Distributors
for the
full range of
PARACLIPSE

Ring us for the latest products from Strong Technologies

- Dishes 65 cm, 90 cm and 2 - 3 m
- LNB's
- Digital Receiver

DISHES

SATECH your no.1 paraclipse distributor for the complete paraclipse range

- Paraclipse Dishes
- exceptional strength and wind resistance
 - accurate reception

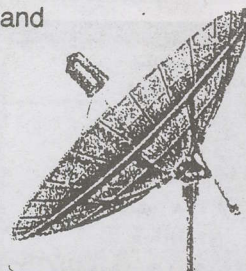
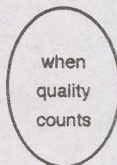

Paraclipse
HIGH PERFORMANCE ANTENNAS

All products available through the following SATECH distributors:

- Satech (Victoria) Tel: (03) 9553 3399
- South Satellite (South Australia) Tel: (08) 8377 0955
- Network Satellite Services (NSW) Tel: (02) 9687 9903
- Norsat (Western Australia) Tel: (08) 9451 8300
- Mathews Electronic Services (New Zealand) Tel: 0800-777376

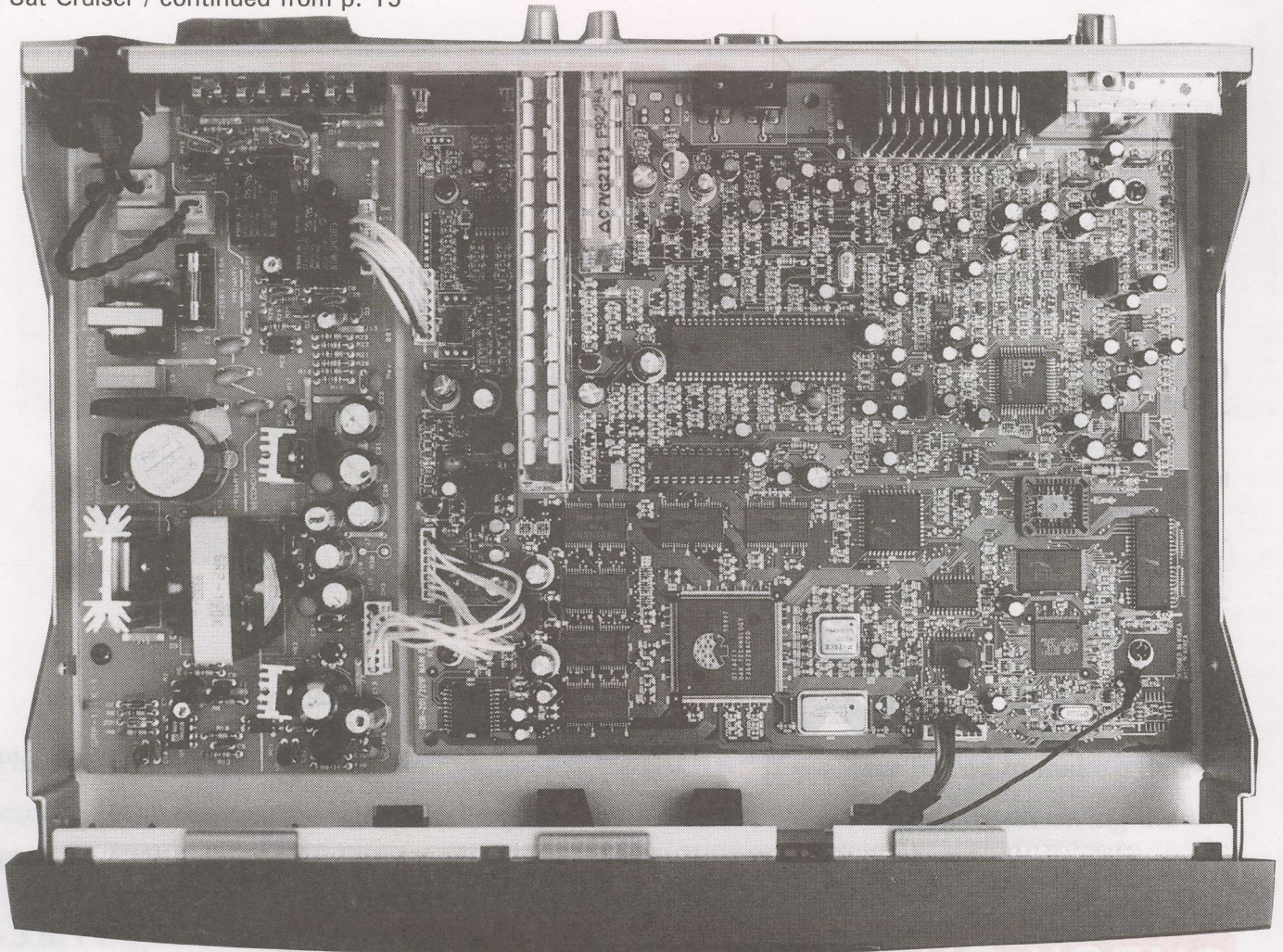

between 1/2 and 3/4. For 7/8, we are not so certain. There is one annoying glitch - on ABC B1 Vt (NT feed) the video freezes and audio stops after extended periods on the same service - it could be the service, but we don't think so as other IRDs don't have this problem. To restart, go up a channel, and back down again. Not annoying - just a fact. The bottom of screen signal level indicator (see below) is "relative" and should not be used as a dish peaking aid. A real carrier to noise ratio signal level indicator would have been a useful addition and is about the only feature missing here.

This is a receiver for the super enthusiast who demands everything in one box. If you plan to sell it to consumers, as an installer you will need to take an extra few hours in set-up to ensure the consumer gets the top notch performance possible. This IRD will command top retail dollar but only if it is properly programmed and the consumer is willing to go through a step by step learning process to access its rich features. This means you should carefully judge the level of skills and dedication of the consumer before you automatically sell him or her a DSR-201P.

The DSR-201P will locate anything on the air, analogue or digital. But the menu sequence is rigid and must be followed exactly. A labelling screen allows you to custom "tag" channels and reception settings.

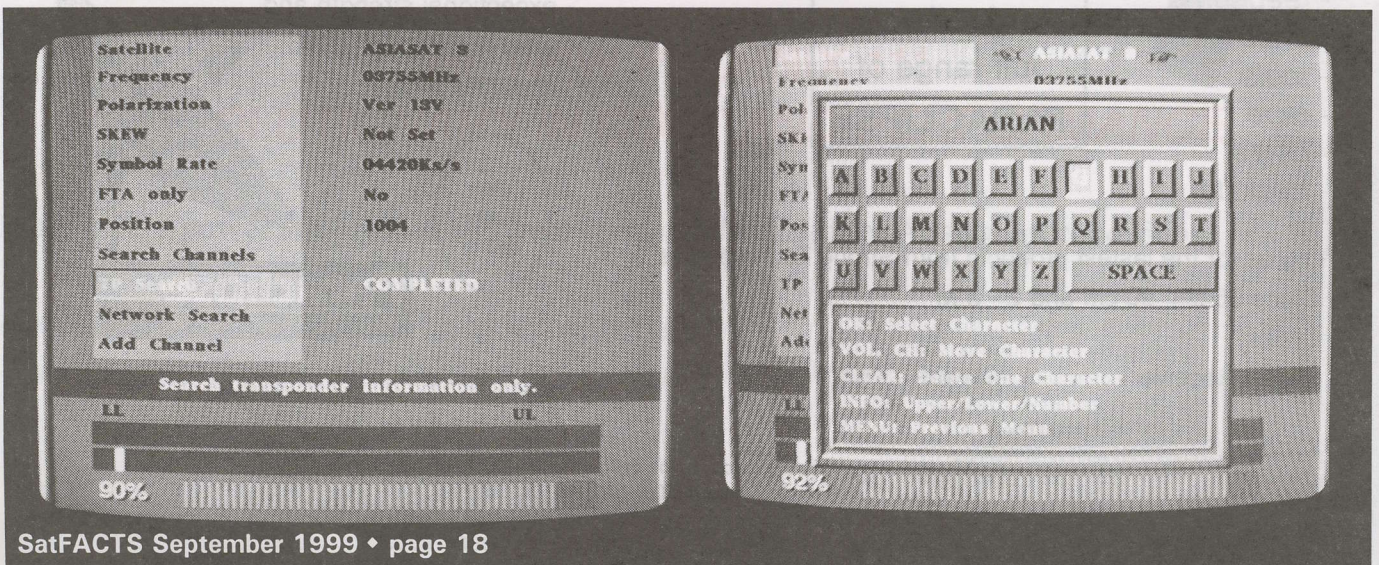

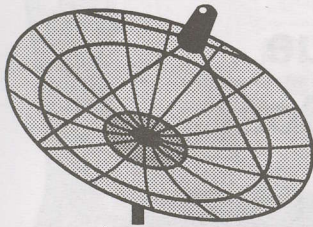

AV-COMM SATELLITE TV EQUIPMENT

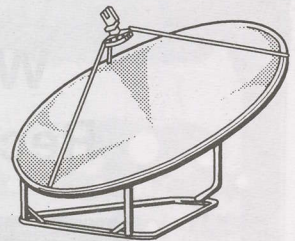

FREE TO AIR DIGITAL SATELLITE RECEIVER R3100

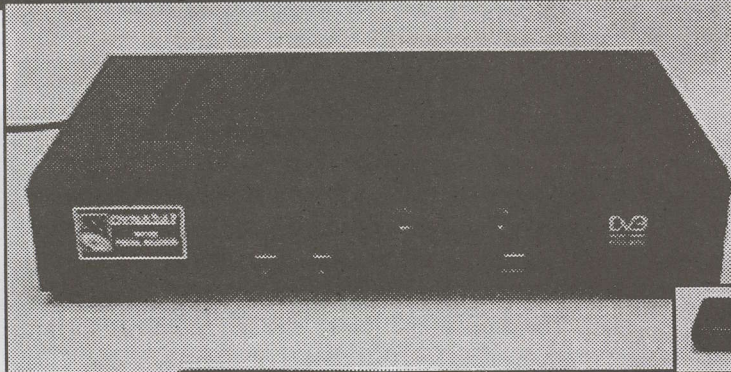

Cat # R3100

ONLY
\$1145

Call
for
export
price

FEATURES

- ◆ 950-2150 extended frequency coverage, C & K band
- ◆ 14/18V LNB polarity selection
- ◆ MCPC & SCPC
- ◆ 22KHz tone switching for dual input ops.
- ◆ Downlink signal margin indicator
- ◆ Dual channel audio
- ◆ Channel "edit" facility
- ◆ 0-12V output for dish selection
- ◆ S-VHS video output
- ◆ Auto FEC detect

DYNALINK MANUAL TUNED RECEIVER R1100

SPECIFICATIONS

- ◆ 950 - 2050MHz IF Input range
- ◆ Low threshold operation
- ◆ Stereo audio
- ◆ 14/18V LNB switching
- ◆ 18/27MHz IF Bandwidth.

Ideal for band scanning, channel monitoring, or as the heart of any home satellite receiving system.

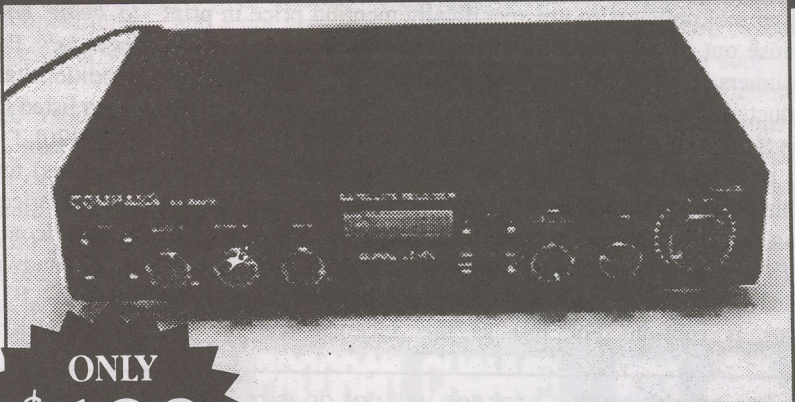

ONLY
\$199

Call for
export price

Cat # R1100

AV-COMM PTY. LTD.

DIRECT IMPORTER ACN 002 174 478
PO BOX 225, BALGOWLAH 2093

TEL: 61 2 9949 7417 9948 2667

FAX: 61 2 9949 7095

VISIT OUR WEB SITE AT

<http://www.avcomm.com.au>

*We reserve the right to improve product performance without notice.

✓YES GARRY, Please send me more info...

Name: _____

Address: _____

P'code: _____

Phone: _____

Approaching throw-away-when broken status

Wonderful World of Analogue Receivers Approaching Zero-Cost

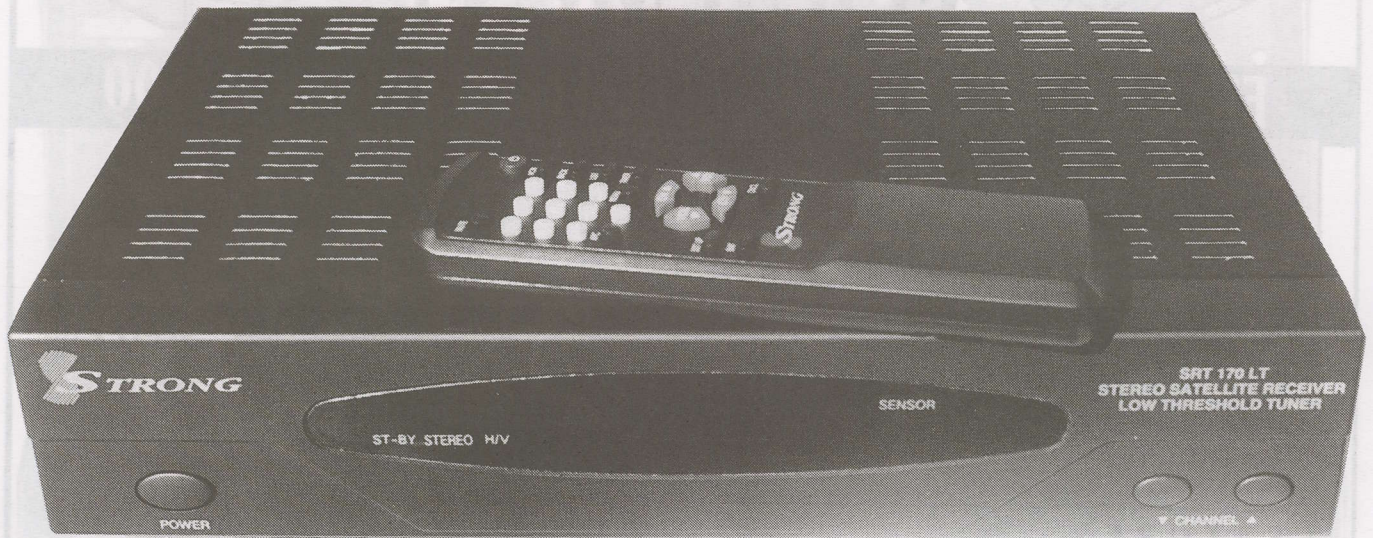

One of the intriguing aspects of our industry is the way pricing always seems to catch up with technology. The first of anything new costs an arm and a leg, and then within some reasonable period of time if the innovation is worthwhile and sales follow, the pricing begins to drop. We are now witnessing what some claim is the "end of the analogue era" with fully featured analogue receivers now dropping to pricing unheard of just a year ago. Witness the Strong SRT-170LT. Our normal policy is to not specifically mention price in print because out of the several thousand readers some are in fact consumers and it becomes increasingly difficult to "sell" product at the retail level if those sharp eyed readers know from SatFACTS what the dealer pays for a gadget.

So here is a puzzle. This threshold extension, nothing-missing analogue receiver costs the installing dealer about the same amount in Australian dollars as someone pays in US dollars to subscribe to SatFACTS for three years. Which makes this item one of the bargains of our time. And the timing is spot-on. For just as this receiver has become

available through SATECH (tel 62-3-9553-3399), the emergence of the analogue market for transmissions from AsiaSat 3 has caught fire. Built around this receiver, a suitable As3 plus InSat 2E home system package can deliver more than a dozen channels of Indian programming, plus a selection from Pakistan and China - to consumers throughout Australia.

Seventeen months ago, a standing advertisement appearing on page 17 of SatFACTS was headlined "The next best thing to being hard wired to the bird ...". It promoted the now legendary Palcom SL-7900RP, a receiver which in a used condition state still commands pricing in the region of (A)\$400 when listed for sale on our SatFACTS Web site. Surprise. The SRT-170LT does virtually everything "the legend" did (and still does) for less than 40% of today's second hand "legend" asking price. The only thing really missing is the dish actuator/controller function. It tunes 900-2150 MHz, has a pair of IF bandwidths (18 and 27 MHz), low-threshold extension for below P5 signals, a range of audio IF bandwidths (110 kHz to 500 kHz), powering for 13 or 18 volt LNBs,

The only thing this package will not do is move your dish. Virtually every analogue encrypted plus FTA format is covered and using a "host/slave" approach, the receiver can be loaded with new memory quickly.



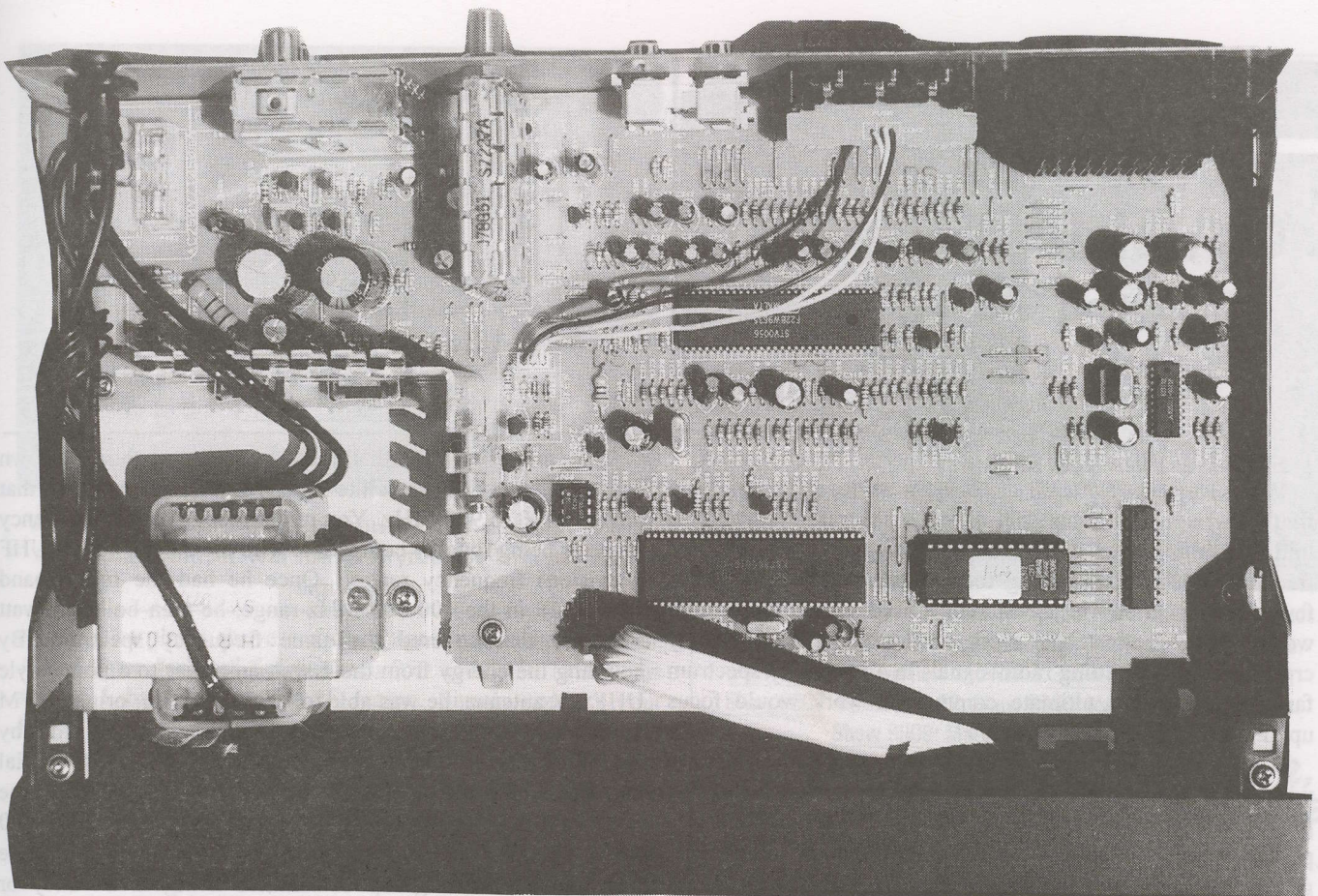

D2-MAC/Filmnet/Videocrypt outputs for external decoders through a pair of SCART sockets and even receiver to receiver "data transfer" using the VCR SCART sockets.

Negatives? The manual is terrible, one of the worst we have seen unless you happen to be an enthusiast. For the consumer, it will make no sense whatsoever. That's the bad news. The good news is that once the installer has the receiver programmed, the IR handheld unit is so similar in operation to most TV and VCR handhelds that anyone can operate it with only a few minutes coaching.

The receiver has a screwdriver adjusted UHF modulator spanning 15 channels, with built in TSG (test signal generator). With two, separate, LNB inputs you can happily operate different antennas for C and Ku or separate LNBs on the same dish. RCA sockets output video and audio (L and R) in addition to the SCART sockets. A "Polarotor" family mechanical polariser strip offers the usual pulse/+5V and ground circuit needed to operate a probe skew device in the feed antenna. The set-up menu is straight forward and once you have entered the satellites and individually located each analogue transponder, the receiver memorises the particular parameters for each channel. Once entered, a "Channel List" button on the remote allows the user to scroll from service to service selecting the one they wish. A factory programmed set of satellites and channels is essentially for people who live in the Middle East and the first thing you will do after turning it on is wipe out the various PAS-4/ArabSat/Turksat listings and start over. It can take 45 minutes to an hour to do this for all satellites in view, which makes the "data transfer" function very handy. If you elect to stock and sell this unit, and keeping one "master" in the shop which has been programmed with all of the available analogue channels, by connecting SCART socket B12 on the "host" receiver to SCART connector B11 on the "slave" receiver, in two minutes time the host has done

all of the in-memory programming transfer to the new unit. One note - you will need a "fully wired" SCART male to male jumper bundle here - pins 10 and 12, often not wired for normal use, are employed for this transfer.

One other note. Not much is likely to go wrong with this receiver. Note in the chassis photo above the total number of parts has been reduced to two monster ICs, three smaller ICs and a not very impressive quantity of resistors and capacitors. The power transformer is a healthy size, the power supply easy and open to work on, and in truth they could have crammed all of this into a box about the size of a LNB. That would have been a mistake however - the consumer wants to show off his satellite receiver and size still counts for something! Oh yes - check page 34 here - *we are giving away a SRT-170LT.*

Everything you need to know is on screen during set-up.



The CABLE Connection

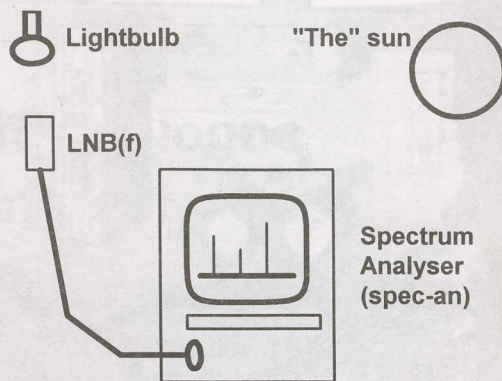
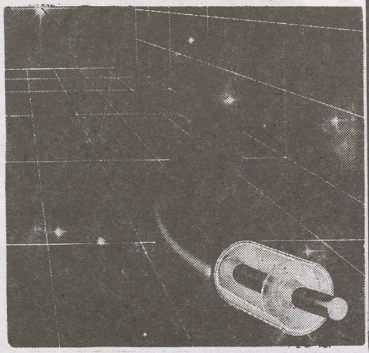

Testing LNB/LNBF units

When Heinrich Hertz first created a device that sent radio frequency signals through the air to a separate receiver, his initial laboratory tests were - quite by accident - conducted in a frequency range approaching today's microwaves. When, a few decades after Hertz, Marconi used his parent's attic workshop to duplicate the work of Hertz, he too began by creating and transmitting radio signals in a frequency spectrum far higher than his ultimate commercial work would focus upon.

If you take a spark plug on your lawn mower and couple (by winding a wire loosely around the spark plug lead near the plug itself) energy from the spark plug to a wire antenna perhaps a metre in length, you can then radiate the radio signal generated by the spark plug all over the neighbourhood. A spark plug is a notorious creator of "square wave pulses" which are - in turn - rich in harmonics. That means that one spark plug, coupled to a suitable length of wire as an antenna, can radiate a rather significant amount of pulsating radio energy over a quite wide area. If you took a rooftop TV antenna and coupled (by winding the center conductor of the coax feed line) to the spark plug, square wave pulses radiated from the TV aerial would probably wipe out several neighbour's TV pictures.

What this illustrates is not a way to be a mean and nasty citizen but rather that all around us, often overlooked, are devices which potentially generate radio frequency signals well into the microwave region. Some of these can be quite useful when you are faced with determining whether one or more pieces of satellite TV equipment is working properly.

More than a decade ago, when C-band TVRO was just getting underway in North America, an innovative firm built a device that generated a 4 GHz region test signal. You could plug in a VCR video and audio line and set the device at the end of your test bench (or several hundred meters away) and then using this test signal as a source, hook up an LNB (LNBF), hold it in your hand and point the open mouth end at the signal source. The test device was basically a "frequency down converter in reverse"; an LNBF backwards as it were. Rather than down convert a 4 GHz signal to a lower IF, this device up converted a lower frequency signal (modulated with the VCR A and V lines or a test bar generator built into the device) to 4 GHz. Some inquisitive folks discovered you could place the feed portion of this device on a 3m dish and recover P5 signals up to several miles away on a second 3m dish equipped with a standard LNB. With 40 dB of antenna gain on both ends, it doesn't take very much actual 4 GHz "power" to cover several miles of distance.

Then a fellow in South Dakota created a method of down converting the 4 GHz satellite signals to a non-standard IF that covered 400 to 900 MHz. You might recognise this frequency range as being roughly compatible with the band 4 and 5 (UHF television) frequency range. Once he had the full C-band "block" IF in the 400-900 MHz range, he then built a 1 watt amplifier that covered the same frequency spectrum. By coupling the energy from the 1 watt amplifier to a home-style UHF TV antenna, he was able to send the entire, original, FM modulated C-band IF range over a distance of up to 5 miles by equipping the receiving locations with another UHF-TV aerial and then employing satellite TV receivers which tuned not the normal 950-1450 IF region but rather the special 400-900 MHz region. With this approach, he was able to install one dish antenna for a group of families living in a valley or isolated area, retransmit the C-band (it could have been Ku as well of course) single polarity 500 MHz IF span to each home. Now individual homes had independent access to any of the satellite TV channels, using inexpensive UHF-TV aerials (some had to be equipped with masthead amplifiers of course - always in the quest for greater distance!).

This particular "experiment" culminated when the South Dakotan created a modification to a commonly available 14" colour home TV receiver that allowed it to tune-in directly the frequency modulated satellite TV signals down converted to the 400-900 MHz region. Using a technique called "slope detection," he was able to get reasonably good quality FM reception on a standard TV set by adding less than (US)\$5 in parts to the TV set.

All of this points up that it is possible to be very creative with UHF and microwave signals if you return to the basics of signal generation and transmission. Start out with a common incandescent filament light bulb. Perhaps you never gave much thought to that Edison device - but it generates a measurable amount of radio frequency energy right through the microwave

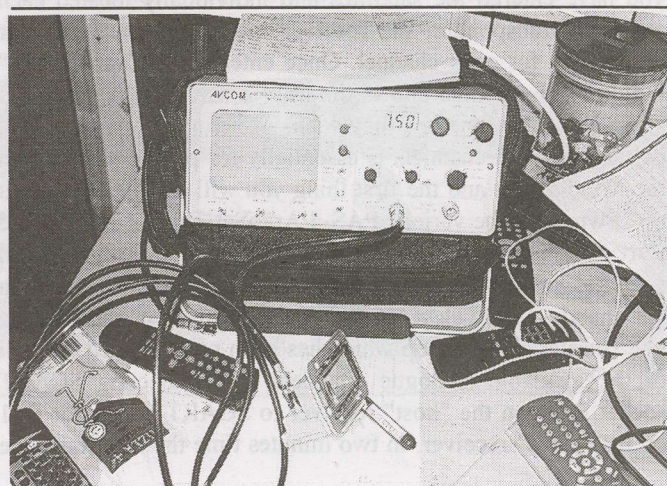

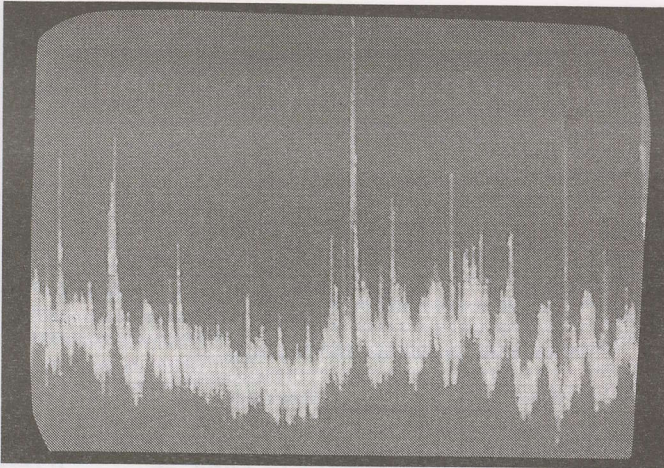

When you point the open mouth of an LNB (or LNBF) around a room, it will find a myriad of "microwave" signals.

region. The photo above is from a spectrum analyser screen. All of those "spikes" fall between 950 and 1450 MHz - the normal L-band or satellite IF region. Simply connect your LNB(f) to an analyser, power them up and point the open end or mouth of the LNB(f) towards a nearby light bulb. With some care you can even calibrate a bench test set-up using an existing light fixture (flescent fixtures also work but not usually as well as incandescent bulbs). Wonder whether an LNB is working? It takes about ten seconds to find out. How well is it working? Create a "calibrated" test range by marking locations on your bench as guides to placing the LNB(f) using a known-good LNB for a reference initially. The world of microwaves - all around you all the time!

TUNE US IN...



Show 9901: Spectrum Analysers - and you. Show 9902: LNBs, feeds.
 Show 9903: Dish antenna critique. Show 9904: Dish marketplace.
 Show 9905: Dr Overflow and Nokia. Show 9906: Uplink tour #1.
 Show 9907: Uplink tour #2. Show 9908: Mark Long's Install tips.
 Show 9909: Mark Long's Digital installs.

Every Saturday and Sunday on AsiaSat 2, KIBC, 8 complete showings of the SPACE Pacific Report, hosted by Bob Cooper.

Full tune-in details, show timings on page 27 here. Sponsored by Av-Comm Pty Ltd, SATECH and Sciteq Pty Ltd. VHS tape copies available - see insert card before page 1.

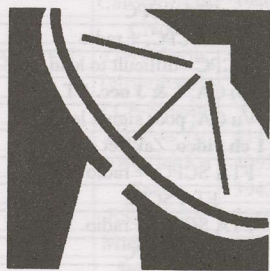

MELBOURNE SATELLITES P/L

ACN 065 270 733
 Established 1992

Direct importers and suppliers of the following world renown products.

KTI
ORBITRON
PATRIOT
JONSA
ANDREW

ECHOSTAR
SCIENTIFIC ATLANTA
NOKIA
IKUSI
DX

GARDINER
CALIFORNIA AMPLIFIER
MTI
CHAPARRAL
ADL

Full range of cables, splitters and connectors.

Phone, fax or write for our 1999 Product SATalogue.

Sales/Warehouse - 84 Bayfield Road, Bayswater Victoria
 Construction Services - 13 Elsum Avenue, Bayswater Victoria
 Postal Address - PO Box 901, Bayswater 3153 Victoria Australia

Phone: (03) 9738 0888
 Fax: (03) 9729 8276

User Friendly Site! www.melbournesatellites.com.au e-mail: sales@melbournesatellites.com.au

SatFACTS Pacific/Asian MPEG-2 Digital Watch: 15 September 1999

Bird	Service	RF/IF & Polarity	# Program Channels	FEC	Msym
I703/57E	Sky News	4143/1007R	1	3/4	5(.632)
	CNBC	4018/1132L	1	3/4	6(.000)
I704/66E	TV5, Adult 21	4055/1095R	4	3/4	27(.500)
	Sky News +	3805/1345R	4	3/4	22(.520)
PAS4/68.5E	Nickelodeon+	4147/1003H	1 reported	1/2	24(.000)
	BBC	3743/1407H	5	3/4	21(.800)
	CCTV	3716/1434H	up to 6	3/4	19(.850)
Ap2/76E	Hmark/Kermit	3720/1430H	4	5/6	29(.270)
	TVB8 +	3849/1301N	4	3/4	13(.238)
	Disney	3880/1270H	3	5/6	28(.125)
	AXN	3920/1230H	up to 8	7/8	28(.340)
Them3/78.5E	ITC	3569/1581H	1	3/4	10(.200)
	MRTV	3666/1484H	1	2/3	4(.442)
	UTV	3920/1230H	6	3/4	26(.662)
	UTV/MCOT	3880/1270H	8	3/4	27(.500)
	Mahar/DD1	3600/1550H	up to 8	3/4	26(.662)
	Myanmar TV	3666/1484H	1	3/4	4(.442)
	TV Maldives	3412/1738V	1	1/2	6(.312)
As2/100.5E	Thai Global+	3425/1725V	up to 7?	2/3	27(.500)
	Euro Bouquet	4000/1150H	5TV, 19r	3/4	28(.125)
	Hubei/HBTV	3854/1296H	1	3/4	4(.418)
	Hunan/SRTC	3847/1303H	1	3/4	4(.418)
	Guan./GDTV	3840/1310H	1	3/4	4(.418)
	Inn. Mongolia	3828/1322H	2	3/4	8(.397)
	Saudi Arabia	3811/1339H	1	3/4	3(.905)
	APTN A-O	3799/1351H	1	3/4	5(.631)
	WTN Jer/Lon	3790/1360H	1	3/4	5(.631)
	Reuters/Sing.	3775/1375H	1	3/4	5(.631)
As2/100.5E	WorldNet/US	3764/1386H	1 + 20 radio	3/4	6(.100)
	Liaoning/Svc2	3734/1416H	1	3/4	4(.418)
	Jiangxi/JXTV	3727/1423H	1	3/4	4(.418)
	Fujian/SETV	3720/1430H	1	3/4	4(.418)
	Hubei TV	3713/1437H	1	3/4	4(.418)
	Henan/Main	3706/1444H	1	3/4	4(.418)
	TVSN	4033/1117V	1	3/4	4(.298)
	Sky Racing	4020/1130V	up to 3TV	1/2?	18(.000)?
	EMTV	4006/1144V	1TV, 2 radio	3/4	5(.632)
	KIBC	3940/1210V	1TV, 4 data	2/3	26(.655)
	Jilin Sat TV	3875/1275V	1	3/4	4(.418)
	HeiLongJiang	3834/1316V	1	3/4	4(.418)
	JSTV	3827/1323V	1	3/4	4(.418)
	Anhui TV	3820/1330V	1	3/4	4(.418)
	Shaanxi/QQQ	3813/1337V	1	3/4	4(.418)
Guang/GXTV	3806/1344V	1	3/4	4(.418)	
Fashion TV	3796/1354V	1	3/4	2(.533)	
Feeds	3785/1365V	1	3/4	5(.632)	
Myawady TV	3766/1384V	1	7/8	5(.080)	
Saudi TV1	3661/1489V	1	3/4	7(.128)	
As3S/105.5E	Arirang TV	3755/1395V	1	7/8	4(.418)
	Star TV	3780/1370V	17(+)-TV	3/4	28(.100)
	Star TV	3860/1290V	14(+)-TV	3/4	27(.500)
	Star TV	3880/1270H	12(+)-TV	7/8	26(.850)
	CNNI	3960/1190H	4(+)-TV	3/4	26(.000)
	Star TV	4000/1150H	7(+)-TV	7/8	26(.850)
Cak1/107.5E	Indovision (S-band)	2.536, 2.566, 2.596, 2.626	33(+)-TV	5/6	20(.000)
Sinosat/110E	Shanghai TV	4106/1044V	1	2/3	4(.443)
C2M/113E	Space TV	4000/1150H	12TV, radio	3/4	26(.655)
	Mega TV	3780/1370V	5TV (?)	3/4	27(.500)
	C Net Taiwan	3760/1390H	11TV, radio	5/6	21(.091)
RCTI	3475/1675H	1	3/4	8(.000)	
JcSAT3/128E	Miracle Net	3990/1160V	3 up to 6	5/6	12(.997)

Receivers and Errata
NDS encrypted, often FTA
Feeds - typically FTA (SCPC)
FTA (Adult 21 believed off air)
Sky News 24 hr, sport, feeds; some FTA
Status unknown - was testing FTA
FTA; 2 audio channels
FTA
PowVu, typ. CA
PowVu, CA
PowVu, CA
Tests, promos, some FTA
FTA
FTA; difficult to load
Irdeto CA (MOSC cards available)
Irdeto (MOSC cards available)
FTA (has included Indian, Skai-TV)
FTA, may not be active
FTA (reaches SE Australia)
FTA
FTA (TV5 teletext)
FTA SCPC, teletext
FTA SCPC, teletext
FTA SCPC, radio APID 81
FTA: #1 Chinese, #2 Mangolian
FTA SCPC, "Ch 1" (not same as 3661V)
FTA SCPC (news feeds)
Mostly CA; some FTA
FTA & CA
FTA; multiple radio channels
FTA SCPC
FTA SCPC, teletext
FTA SCPC, + radio
FTA SCPC
FTA SDCPC, + radio
FTA SCPC - difficult to load
(Irdeto) CA; 1 & 3 occ. FTA
PowVu CA; poor signal level
FTA 1 ch video , ZakNet data CA
FTA SCPC, + radio
FTA SCPC
FTA SCPC, + radio
FTA SCPC
FTA SCPC
FTA SCPC
FTA SCPC, now easy to load
FTA & CA, feeds
FTA SCPC - difficult to load
FTA SCPC; also see 3811H-not same
FTA SCPC; very strong signal
NDS CA (Pace DVS211)
NDS CA (Pace DVS211)
NDS CA (Pace DVS211)
PowVu CA; some FTA fed channels
NDS CA (Pace DVS211)
NDS CA using RCA/Thomson, Pace IRDs; improved reliability since June
FTA SCPC, difficult to load
CA uses "floating sequence" system
CA, unknown system
CA but subscriptions available
FTA SCPC; may not be permanent
PowerVu; TBN #3 FTA , some CA

Bird	Service	RF/IF & Polarity	# Program Channels	FEC	Msym
LMI AP1/130	THT	3725/1425L	1	3/4	6(.108)
	THT	3675/1475L	1	3/4	6(.108)
Ap1A/134e	Gansu TV	3769/1381V	1	1/2	6(.930)
Ap1/138e	Reuters	3742/1408V	1	3/4	5(.632)
	Viacom	3860/1290V	up to 6	3/4	30(.000)
Optus B3/156	SDTV	3980/1170V	1	3/4	4(.686)
	Mediasat	12.336V	6TV, 3+ radio	2/3	30(.000)
Optus B1/160	Aurora	12.407V		2/3	30(.000)
	Aurora	12.532V		2/3	30(.000)
	Aurora	12.595V		3/4	30(.000)
	Aurora	12.720V		3/4	30(.000)
	Austar/Foxtel	12.438H		3/4	29(.473)
	Austar/Foxtel	12.564H		3/4	29(.473)
	Austar/Foxtel	12.626H		3/4	29(.473)
	Austar/Foxtel	12.688H		3/4	29(.473)
PAS8/166E	ABC NTfeed	12.256V	1TV, 3 radio	3/4	5(.026)
	Central 7	12.354V	1TV	3/4	3(.688)
PAS2/169E	Sky NZ	12.391/418V		3/4	22(.500)
	Sky NZ	12.518/546V		3/4	22(.500)
	Sky NZ	12.644V		3/4	22(.500)
	Imparja feed	12.367H	1	3/4	5(.424)
	Pacific Time	12.286V?	10TV	3/4	26(.470)
	ABCInterch.	12.312H	1	3/4	6(.978)
	ABCInterch.	12.321H	1	3/4	6(.978)
	Pacific Time	12.326V?	8TV	3/4	27(.500)
	ABCInterch.	12.330H	1	3/4	6(.978)
	Pacific Time	12.366V?	9TV	3/4	26(.470)
	TARBS	12.526H	12+ TV	3/4	28(.067)
	NHK Joho	4065/1085H	5TV, 1 radio	3/4	26(.470)
CalBqt/PAS8	3940/1210H	up to 5TV	7/8	27(.690)	
CNNI	3780/1370H	3, up to 5 TV	3/4	25(.000)	
PAS2/169E	GWN Perth	12.265V	4TV, 7 radio	1/2	16(.200)
	TelstraBendig	12.300V	2	1/2	21(.997)
	TCS-Singap.	4183/967V	2	1/2	6(.620)
	HK PowVu	4148/1002V	up to 8	2/3	24(.430)
	NBCHonKn	4093/1057V	5, up to 7	3/4	29(.473)
	Feeds	3942/1208V	1 or 2	2/3	7(.497)
	ESPN USA	3860/1290V	7TV, 2 data	7/8	26(.470)
	Middle East	3778/1372V	4	3/4	13(.331)
	Service 1	3761/1389V	1	3/4	6(.620)
	BBC + TFC	3743/1407V	3 to 5	3/4	21(.800)
	CCTVPowV	3716/1434V	5 typical	3/4	19(.850)
	NTV Japan	4174/976H	1	3/4	5(.632)
	Feeds	4138/1012H	1	3/4	6(.620)
	CNNI HK	3996/1154H	1	3/4	9(.998)
	Feeds	3867/1183H	1	2/3	6(.618)
	7thDyAdven	3957/1193H	1TV, 14 audio	3/4	7(.000)
	Feeds	3939/1211H	2 (typ NTSC)	2/3	6(.620)/7(.498)
	Cal PowVu	3901/1249H	up to 8	3/4	30(.800)
	Disney	3804/1346H	3	5/6	21(.093)
	Discovery Sing	3776/1374H	8 typ	3/4	21(.093)
Satcom 1-6	3743/1407H	up to 5	7/8	19(.465)	
I702/177E	AFRTS	4177/973LHC	8TV, 12+ rad	3/4	26(.694)
I701/180E	ThaiBouquet	12.650H	up to 3 TV	1/2	17(.800)
	TVNZ	4195/955RHC	1	3/4	5(.632)
	TVNZ/BBC	4186/964RHC	1	3/4	5(.632)
	TVNZ	4178/972RHC	1	3/4	5(.632)
	TVNZ/APTN	4170/980RHC	1	3/4	5(.632)
	AFRTS Pac.	4175/975LHC	3 radio (only)	2/3	3(.679)
RFO-Canal+	4095/1055L	7TV, 5+ radio	3/4	27(.500)	

Receivers and Errata
PAL typ. 0500-2100UTC, FTA Russia
Parallel - 3725 after analog shut down
FTA SCPC (NT, Aust only)
FTA SCPC (NT, Aust only)
FTA, CA (NT, Aust only)
FTA SCPC (NT, Aust only)
PowVu but mostly FTA ; TRT, Thai5
CA, \$65 smart card required (p. 25)
CA, \$65 smart card required (p. 25)
CA, \$65 smart card required (p. 25)
CA, \$65 smart card required (p. 25)
CA, subscription available Australia
CA, subscription available Australia
CA, subscription available Australia
CA, subscription available Australia
FTA, Sydney -30 minutes time zone
FTA, purpose here unknown
NDS CA, subscription available NZ
NDS CA, subscription available NZ
NDS CA, subscription available NZ
FTA, difficult to load, not full time
Viaccess CA, some FTA at times
PowVu, FTA, news feeds
PowVu, FTA, news feeds
Viaccess CA, some FTA at times
PowVu, FTA, ABC Melbourne feeds
Viaccess CA, some FTA at times
'MDS' CA, IRDs useless other svcs
PowVu CA & FTA; subscription avail
PowVu CA & FTA
PowVu, FTA at this time
PowVu CA-WA only, D9234 required
PowVu CA, private, not available
PowVu FTA
PowVu CA, some FTA
Philips MPEG-2, FTA
(PowVu) FTA, occ. feeds
PowVu CA, Ch 12 bootloader updates
FTA - low level, difficult to load
(PowVu) FTA, occ. feeds
(PowVu) CA & FTA - BBC #3 FTA
(PowVu) FTA, # pgm chs varies
FTA SCPC feeds (occasional use)
FTA occasional feeds
Reverse link HK to Atlanta, feeds, FTA
FTA occ. (sport) feeds
1900-2030UTC; not daily, PowVu FTA
FTA-typ. NTSC-occ. sport, shuttle
(PowVu) CA & FTA
PowVu CA
PowVu CA
currently FTA, lowlevel, Mid East feeds
PowVu CA
Thai5 service, tests, FTA
DMV/NTL occ. feeds, typ CA
DMV/NTL occ. feeds, typ CA
DMV/NTL occ. feeds, typ. CA
DMV/NTL occ. feeds, typ. CA
PowVu CA radio, very strong level
#1, 2 CA - rest FTA-France to Polyn.

SatFACTS Digital Watch: Supplemental Reference Data / September 1999

Bird	Service	RF/IF & Polarity	# Program Channels	FEC	Msym								
(1701/180E)	SPN Nauru	4081/1055L	1	3/4	4(.730)	<table border="1" style="width: 100%; border-collapse: collapse;"> <thead> <tr> <th style="text-align: center;">Receivers and Errata</th> </tr> </thead> <tbody> <tr> <td style="text-align: center;">FTA; currently off the air</td> </tr> <tr> <td style="text-align: center;">PowVu CA; Auckland net feeds</td> </tr> <tr> <td style="text-align: center;">FTA SCPC; East Hemi Beam-Tahiti</td> </tr> <tr> <td style="text-align: center;">SCPC, mixed CA & FTA, feeds</td> </tr> <tr> <td style="text-align: center;">SCPC, mixed CA & FTA, feeds</td> </tr> <tr> <td style="text-align: center;">PowVu CA & FTA; #3 TBN</td> </tr> </tbody> </table>	Receivers and Errata	FTA; currently off the air	PowVu CA; Auckland net feeds	FTA SCPC; East Hemi Beam-Tahiti	SCPC, mixed CA & FTA, feeds	SCPC, mixed CA & FTA, feeds	PowVu CA & FTA; #3 TBN
Receivers and Errata													
FTA; currently off the air													
PowVu CA; Auckland net feeds													
FTA SCPC; East Hemi Beam-Tahiti													
SCPC, mixed CA & FTA, feeds													
SCPC, mixed CA & FTA, feeds													
PowVu CA & FTA; #3 TBN													
	NZ Prime TV	4024/1126L	1	2/3	6(.876)								
	RFO Polycast	3858/1292L	1	3/4	4(.566)								
	TVNZ (TL)	3854/1293R	1	3/4	5(.632)								
	TVNZ	3846/1304R	1	3/4	5(.632)								
	10 Australia	3765/1385R	6	7/8	29(.900)								

BOUQUETS - FTA vs. CA: Listings here show SCPC (single channel per carrier) and MCPC (multiple channels per carrier) digital transmissions which "more or less" conform to the MPEG-2 DVB "standard." Unfortunately, "conforming to the standard" is interpreted differently by the various transmission equipment suppliers - of which, Scientific Atlanta is the most notorious with its PowerVu proprietary (that means "unique to SA") method of creating MPEG-2. If you want to see REAL MPEG-2 DVB-Compliant (as in world standard) signals - try AsiaSat 2, European Bouquet (4000/1150Hz). SA "modifies" their PowerVu format in an attempt to force each programmer using its uplink equipment to also use its proprietary (PowerVu) receivers. PanAmSat, closely linked to Scientific Atlanta, virtually insists that any digital service user of their satellites use PowerVu format transmission equipment. The good news is that some clever non-PowerVu receiver designers and receiver software writers have created "quasi-PowerVu" decoding routines which in many cases outperform the PowerVu originals. If your use requires access to one or more PowerVu CA (conditional access) service, you have no choice but to purchase a PowerVu receiver. If you are only interested in FTA (free to air) PowerVu services, there are many lower cost options (see below).

All services listed in bold face (i.e. **SPN Nauru**) are FTA. When MCPC services are FTA, they are also listed bold face (i.e. **Euro Bouquet**). When there are mixed CA and FTA programme channels in a MCPC bouquet, see right hand column for a bold face indication of this (i.e. **some FTA**). The primary (mostly or total) FTA MCPC bouquets are as follows: PAS4/68.5E: CCTV (3716H); Thaicom 3/78.5E: Mahar (3600H), Thai Global (3425V); As2/100.5E: European Bouquet (4000H); Optus B3 /156E: Mediasat (12.336V); PAS8/166E: NHK Joho (4065H), California Bouquet (3940H), CNNI (3780H); PAS2/169E: NBC Hong Kong (4093V), Middle East (3778V), BBC + (3743V), CCTV (3716V), California PowVu (3901H), Satcom 1-6 (3743H); Intelsat 701/180E: RFO (4095LHC), 10 Australia (3765RHC). There are far more SCPC FTA digital services than MCPC FTA digital services.

MPEG-2 DVB Receivers: (Data here believed accurate; we assume no responsibility for correctness!)

ADI MediaMate. FTA, NTSC+PAL outputs. (Pacific Digital Sys. Pty Ltd, tel 61-2-8765-0270)
AV-COMM R3100. FTA, excellent sensitivity (review SF May 1998); new version Sept. '99. Av-COMM Pty Ltd, 61-2-9949-7417.
Benjamin DB6600-CA. FTA, Foxtel/Austar w/CAM+card. Try Steffen Holz 687-438-156.
Grundig DTR1100. Mfg by Panasat (SA), very similar to Panasat 630; out of production, Irdeto capable. See Av-COMM above.
Humax F1-CI. Primarily sold for TRT (Australia), does (limited) PowerVu, other claims unsubstantiated.
Hyundai-TV/COM. HSS100B/G (Pacific), HSS-100C (China) FTA. Different software versions; 2.26/2.27 good performers, 3.11 and those with Nokia tuners also good; later 5.0 not good. SATECH (V2.26) 61-3-9553-3399; Skandia (V3.11) 61-3-9819-2466.
Hyundai HSS700. FTA, PowerVu, SCPC/MCPC. Review SF March 1999. Kristal Electronics, 61-7-4788-8906.
MediaStar D7. FTA, preloaded w/ known services, exc. software (review SF July 1998). MediaStar Comm. Int. 61-2-9618-5777
MultiChoice (UEC) 660. Essentially same as Australian 660, not grey market contrary to reports. Sciteq tel 61-8-9306-3738
Nokia "d-box" (V1.7X). European, FTA, may only be German language, capable of Dr. Overflow software. Tricky to use.
Nokia 9200. When equipped with proper CAM, does Aurora, pay-TV services provided software has been "modified" with Dr Overflow or similar program (www.BAKKERELECTRONICS.COM). Has factory 12 mo. warranty. Peter Older, tel 61-3-5133-7911, mobile 61-0418-386287
Nokia 9500/9600. Numerous versions for different world parts; not distributed in Pacific but assistance from Av-Comm Pty Ltd.
Nokia 9800. Latest single chip version (August 1999), with CI and Irdeto capable. No hands on experience yet.
Pace DVS211. NDS CA (no FTA) for Star Asia, previously used for Indovision. (Solution 42, 61-2-9820-5962)
Pace DGT400. Originally Galaxy (Now Foxtel+Austar). Irdeto, some FTA with difficulty (Foxtel Australia 1300-360818)
Pace DVR500. Original DGT400 modified for NBC (PAS-2) affiliate use, with CAM equivalent to DGT400 but more reliable.
Pace "Worldbox" (DSR-620 in NZ). Non-DVB compliant NDS CA including Sky NZ, no FTA; similar "Zenith" version.
Pacific Satellite DSR2000. Clone of Mediastar D7 (see above).
Panasat 520/630/635. MCPC FTA, Irdeto capable, forerunner UEC 642, 660. Out of production, spares fax ++27-31-593-370.
Panasonic TU-DS10. FTA + Irdeto CA; one of 2 IRDs approved by Optus for Aurora, but no longer available in Australia.
Phoenix 111, 222. PowVu capable, NTSC, good graphics, ease of use. (SF 111 review May 1999). SATECH - see below.
Phoenix 333. FTA SCPC, MCPC, analogue + dish mover. Detailed SF review Nov. 1998. SATECH 61-3-9553-3399.
PowerCom. FTA, PowVu, NTSC, excellent sensitivity. NetSat 61-2-9687-9903.
PowerVu (D9223, 9225, 9234). Non-DVB compliant MPEG-2 unless loaded with software through ESPN Boot Loader (see below). Primarily sold for proprietary CA (NHK, GWN+ PAS-2 Ku, CMT etc). Scientific Atlanta 61-2-9452-3388.
Praxis/DigiMaster 9600 MKII/9800AD. FTA, PowVu+analogue, withdrawn from sale in Pacific (was Skyvision-below)
Praxis 9800 ADP. FTA SCPC/MCPC, PowVu, analogue, positioner. SF review Dec '98; withdrawn from Pacific sale (below).
Prosat 2102S. FTA SCPC/MCPC, NTSC/PAL, SCART + RCA. Sciteq 61-8-9306-3738.
Samsung DSR2400. FTA, reported not sensitive, recently released Asia - no Pacific sources.
SatCruiser DSR-101. FTA SCPC/MCPC, PowVu, NTSC/PAL. (Skyvision Australia 61-2-6292-5850, Telsat 64-6-356-3749)
SatCruiser DSR-201P. FTA SCPC/MCPC, PowVu, NTSC/PAL, analogue, positioner - review this issue (Skyvision - see above).
Skandia SK888 (aka DigiSkan-SMS). FTA MCPC, Irdeto CAM+software upgrade. Out of production; Skandia 61-3-9819-2466
UEC642. Designed for Aurora (Irdeto), approved by Optus; limited other uses. Nationwide 61-7-3252-2947.
UEC660. Upgraded UEC642, used by Sky Racing Aust., Foxtel-limited uses for FTA. (Nationwide - above).
Yuri HSS-100C. FTA, clone of Hyundai, V2.27 software custom to Australia (Nationwide-above).

Accessories:

Aurora smart cards. Sold independent of IRD purchase by Sciteq (\$65), other sources require IRD purchase 61-8-9306-3738.
PowerVu Software Upgrade: PAS-2, 3860/1190V, 26.470, 7/8; Tune pgm ch 12 and follow instructions (do not leave early!)

SatFACTS Pacific/Asian FTA ANALOGUE Watch: 15 September, 1999

Copyright 1999: SatFACTS, PO Box 330, Mangonui, Far North, New Zealand (<http://www.satfacts.kwikkopy.co.nz>)

BIRD/Location	RF/IF & Polarity	Service	Errata
<u>I703/57E</u>	3808/1342R	Udaya TV	
	4052/1098R	WorldNet	VOA subcrs.
	4178/972L	MTA Inter.	
<u>I604/602/60E</u>	4166/984	various feeds	
<u>I704/66E</u>	3765/1385R	tests	
	4015/1135L	Mongolia	(SECAM)
<u>PAS4/68.5E</u>	3743/1407V	RTPi	(+ radio subcr)
	3864/1286V	BBC World	
	3907/1243H	Sony TV	Hindi
	4034/1116V	Doordan	(various)
	4087/1063H	CNNI	
	4110/1040H	TNT/Cartoon	
	4113/1037V	Series Ch.	
	4182/968H	MTV	
<u>PAS7/68.5E</u>	3470/1680V	test signal	
<u>AP2R/76E</u>	3745/1405V	Vasta Music	(P5 in NSW)
	3760/1390H	TEN tests	
<u>Thaicom3/78E</u>	3871/1279H	TVT	
	3760/1390V	Army TV	
	3690/1460V	MRTV	
	3685/1465H	Myanmar TV	
	3616/1534V	ETN	(new ch name)
	3576/1574V	ATN Bangalr	Bengali
	3554/1596V	RAJ Plus	
	3536/1614V	Punjabi TV	(occ service)
	3514/1636V	Falak TV	
	3489/1661H	Vasta Music	occ tests
	3465/1685V	RAJ-TV	
<u>Express 6/80E</u>	3672/1478L	TK Rossija	(north beam)
<u>InSat 2E/83E</u>	3481/1669V	Sun TV	
	3575/1575V	Vijay/Asianet	aud. 5.5/6.6
	3810/1340V	DD1-Tamil	"
	3850/1300V	DD1-National	"
	3930/1220V	DD2 Metro	"
	3970/1180V	Teluga 1	"
	3998/1152V	sport feeds	"
	4035/1115V	Sun TV	"
	4060/1090V	Surya/Sun TV	"
	4093/1057V	DD7	"
<u>ChnStr1/87.5E</u>	3875/1275H	occ feeds	P4 NSW, Ntsc
<u>ST1/88E</u>	3550/1600V	test card	
	3582/1568V	Nila TV	(vintage TV)
<u>CIS S6/90E</u>	3675/1475R	RTR1	P3 NSW
	3875/1275R	Orbita 1	
	3916/1234R	RTR II	
	3935/1215R	Orbita II	
<u>MeSat-1/91.5E</u>	3710/1440H	VTV1,2, 4	
	3880/1270H	RTM-1	
<u>InSat 2B/93.5E</u>	4165/985H	India Metro	NSW on 3.7m
	4125/1025V	India National	NSW on 3.7m
	4080/1070V	DD7 (Tamil)	
	4070/1080H	DD9	
	3970/1180V	DD9 (Kan.)	
	3882/1268V	DD1	
	3840/1310V	DD?	
	3762/1388V	DD4	
<u>AsSat2/100.5E</u>	3642/1508H	ERTU Egypt	
	3660/1490V	feeds, tests	
	3680/1470H	feeds	

BIRD/Location	RF/IF & Polarity	Service	Errata
(As2/100.5E)	3860/1290V	feeds	
	3885/1265H	WorldNet	VOA subcrs
	3960/1190H	CCTV4	
	3980/1170V	RTPi	+5 radio svcs
<u>CIS S21/103E</u>	3675/1475R	RTR	
	3875/1275R	Vrk Apt	
<u>AsSat3S/105.5</u>		CETV	
(temp FTA)	3800/1350H	Star Sport	NTSC
(temp FTA)	3840/1310H	Channel [V]	NTSC
(temp FTA)	3920/1230H	Phoenix Ch	NTSC
	3940/1210V	Zee India	
	3980/1170V	Zee TV	
	4060/1090V	Zee Cinema	(Starcrypt)
	4100/1050V	PTV2/World	
	4120/1030V	CCTV	NTSC
<u>PalapB2R/10E</u>	4000/1150H	TVRI	Telekom replace
<u>PalapC2/113E</u>	4183/967V	TPI/TVRI	
	4160/990H	(France) TV5	
	4140/1010V	Brunei + feeds	
	4120/1030H	MTV Asia	
	4080/1070H	Herbalife	2100HK/NTSC
	4040/1110H	CNBC	
	3970/1180V	CNNI	
	3900/1250V	Malaysia TV3	CA and FTA
	3880/1270H	Aust ATN7	
	3840/1310H	TVRI	tests
	3765/1385H	NBC, CNBC	feeds
	3742/1408V	RCTI	English subcr
<u>AsSat 1/122E</u>			+/-1d. inclined
<u>ChinSat 6/125E</u>	4085/1065V	feeds	seldom seen
<u>JcSat3/128E</u>	4085/1065V	test card	NTSC. 6.8 aud.
<u>AMI-LP1/130E</u>	3675/1475L	NTV/Moscow	off 1400 UTC
<u>Ap1A/134E</u>	4160/1050V	CETV	
	3980/1170V	CETV1	
	3900/1250V	CETV2	
<u>Ap1A/138E</u>	4160/990H	CCTV7	
<u>S7/140E</u>	3675/1475R	ORT Moscow	+/-4d. inclined
	3875/1275R	feeds, tests	
<u>Ag2/146E</u>	3787/1363H	GMA	P1/2 s. eqtr
<u>Me2/148E</u>	4080/1070H	test card	occ. use
<u>PAS8/166.5E</u>	3865/1285H	Napa test card	not fulltime
<u>PAS2/169E</u>	3940/1240V	Napa test card	
<u>1802/174E</u>	4166/984R	Feeds	
	4177/973R	Feeds	
<u>I702/177E</u>	4166/984R	Feeds	inc. KBS Korea
	4187/963R	Occ. feeds	
<u>I701/180E</u>	3810/1340R	Occ. feeds	
	3841/1309L	RFO	East Beam
	3845/1305R	Occ. feeds	inc. from USA
	3930/1220R	USA net feeds	FTA & encrypt
	3975/1175R	Occ. feeds	
	4060/1090L	Occ. feeds	
	4130/1020L	Occ. feeds	

Oddball Formats

PAS4/68.5E	3785/1365V	Discovery India	BMAC
	3860/1290H	ESPN India	BMAC
<u>Ap2/76E</u>	3960/1190H	HBO Asia	GI Digicipher2
<u>C2/113E</u>	3930/1220H	Filip. Peo. Net	GI 1.5 MPEG
<u>Ap1/138E</u>	4100/1050V	ESPN	BMAC
<u>PAS2/169E</u>	3836/1341H	ABS/CBN	GI 1.5 MPEG
	3989/1161V	Fox/Prime	SA1.5MPEG

BEGINNER'S CORNER

Analogue transmission is forgiving of installation or receiving system errors. Digital is not. An analogue weak signal, caused by your installation mistake or because the satellite signal is weak, simply results in noisy, poor quality reception. Digital reception has a built-in "squelch" circuit - if the signal is not strong enough to produce a blemish free picture, there is no reception at all. Analogue receivers with "threshold extension" partially compensate for weak reception; there is no corresponding "threshold extension" device available for digital reception. Installation of a digital system requires some method of determining when the antenna, feed, LNB(f) are "peaked" to the satellite signal source. Some receivers have an on-screen display to assist in peaking reception. Lacking that, a "Bit Error" (BER) measuring device is recommended. Failure to peak the receiving system often results in no-reception when it rains or when the dish gyrates during high winds. If a satellite has both digital and analogue transmissions, you can use an analogue signal to peak the reception (even an untrained eye will quickly be able to discern when the picture is better or worse during dish adjustments) - and once the dish is peaked "to the satellite" using an analogue signal, the digital transmissions from the same satellite will also be peaked.

DISH: At C-band, either a mesh or solid reflector give equivalent performance. No, signals do not go "through" the mesh at C-band. At Ku-band, mesh is not always a good choice - at the very least, it should be "micro-mesh" or otherwise Ku-rated. This means it has much smaller holes than is acceptable at C-band. **LNB(f):** Sensitivity is determined by the noise figure (C-band) or noise temperature (Ku). Gain is less critical - anything greater than 50 dB is usually adequate. C-band noise temperatures in the region of 20 degrees (K or Kelvin) is state-of-the-art. Ku-band noise figures of 0.6dB are state-of-the-art. **Feed:** Energy from the satellite is intercepted by the parabolic reflector, and focused to a point in front of the dish. To collect this energy, a small "feed antenna" is installed at this focal point. The feed antenna must be mated or matched to the reflector - not all feeds work properly with all reflectors and significantly better system performance results from a properly "matched" system.

ADVANCED INFORMATION

Irdeto conditional access has been compromised by European card manipulators. Nokia model 9200 receivers equipped with version 2.X or higher CAMs are popular with hackers because when modified with "blocker" software, MOSC (modified original smart cards) appear at this stage to be immune from ECM (electronic counter measure) attempts by pay-TV operators to shut-down unauthorised cards. Virtually all of the hacker information exchange takes place using Internet. SatFACTS will not list Pacific region hacker sites but does recommend for your own education the Internet online discussion group: <http://www.thoic.com/cgi-bin/forumdisplay.cgi?action=topics&number=15&SUBMIT=Go>. Austar and Foxtel are preparing a major effort to correct for ex-Galaxy technology and smart card techniques. Australian law is 20 years plus behind current technology, and very possibly is not modern enough to deal with current hacking techniques and technology. New Zealand law, in comparison, very specifically makes it a violation to deal in hacked products or services. Providers of MOSC devices operate from Africa, Europe and Asia and anyone dealing with these firms must send funds out of country. Card hackers do not accept credit cards and most will not accept bank checks (personal checks are NEVER accepted). Hackers of MOSC products used in Australia operate outside of normal business society, do not reveal their true identity nor location, and frequently change their (Internet) E-mail addresses. European hacked cards have reached a level of acceptance that includes local satellite dealers and installers actually stocking (for resale) cards for local customers. European satellite magazines (such as What Satellite, Tele-Satellit) routinely carry full page, four colour smart card advertisements. Nothing approaching this level of openness exists elsewhere although North American groups do make wide use of Internet. New Zealand's terrestrial pay-TV encryption system, based upon European technology, is widely discussed at Internet hacker sites with step-by-step instructions for hacking cards. The New Zealand NDS based satellite system cards have not been hacked to date, although a similar system in use in North America has been widely hacked (<http://www.gladiaortestcards.com>). An Australian trade association of pay-TV operators has petitioned legislators to create new laws to deal with the threat of open distribution of hacked products; on September 2, (Australian) Attorney General Daryl Williams asked the House to approve 'Copyright Amendment (Digital Agenda) Bill 1999'. Details of this pending legislation are available at <http://www.apf.gov.au> (also see p. 32 here).

TUNING IN THE INDUSTRY'S TV PROGRAMME

SPACE Pacific, the Asia-Pacific industry membership trade association, has produced (and continues to produce) a series of one hour television programmes. These "SPACE Pacific Report" shows, hosted by Bob Cooper, cover a range of topics of interest to installers and enthusiasts. Show numbers and content are as follows: #9901- Spectrum Analyser techniques, #9902- Feeds and LNBS, #9903- Dish antenna designs and problems, #9904- The dish marketplace, and, "tiny parts," #9905- Dr Overflow (Nokia) software, #9906- How the uplink works (tour of RCA's Vernon Valley site), #9907- Uplink Two, including uplink transmitters, #9908- Digital Basics (Mark Long), #9909- Real World Installs (Mark Long). "Report" is broadcast by Subic Bay uplinked service KIBC on AsiaSat 2 (3940/1210Vt, SR 26.655, FEC 2/3), typically to the following UTC schedule: Saturdays: 00.30 (12.30NZ, 10.30Aust East, 08.30 WA); 15.05 (03.05 Sunday NZ, 01.05 Sunday AE, 23.05 Saturday WA); 19.05 (07.05 Sunday NZ, 05.05 Sunday AE, 03.05 Sunday WA); 22.30 (10.30 Sunday NZ, 08.30 Sunday AE, 06.30 Sunday WA). Sundays: 04.00 (16.00NZ, 14.00AE 12.00WA), 09.10 (21.10NZ, 19.10AE, 17.10WA), 17.10 (05.10NZ Monday, 03.10AE Monday, 01.10WA Monday), 21.25 (09.25NZ Monday, 07.25AE Monday, 05.25WA Monday). Note: Because KIBC is mixed with the ZakNet (Internet) delivery service, you MUST load PID numbers to bring up reception. This requires an IRD that is capable of accepting specific PID/PCR numbers. The procedure is to load KIBC in the normal manner, then enter the PID entry menu of your IRD and enter (following your IRD instructions) VPID 35, APID 36, PCR 35. KIBC will then play and be recallable at will once loaded in this manner. The show number is given at the start of each showing; KIBC does vary the show sequence and may begin with one version on Saturday and switch to another on Sunday. SPACE Pacific attempts to pre-announce which show(s) will appear through the SatFACTS Web site prior to each weekend (<http://www.satfacts.kwikcopy.co.nz>). Shows are digitally mastered and VHS copies are available from SPACE Pacific - see insert card between front cover and page 1 in this issue.

WITH THE OBSERVERS

AT PRESS DEADLINE

Word that the failed Orion 3 satellite will be replaced through a leasing arrangement with ApStar raised hopes 139E would fire up soon. Sadly, not so. Ap2R has been leased, in place at 76E, by Orion as an "interim service provider" until Orion 3R can be built and launched. Yes, 76E may come alive - alas, not 139E - yet.

ApStar 1/138E: Macau TV is now on 3885/1265Vt, SR 4.444, FEC 3/4.

ApStar 1A/134E: Hainan TV new on 3745/1405Vt, SR 6.930, FEC 1/2.

AsiaSat 1/122E: Unmodulated test carriers reported 3760/1390Hz, 3920/1230Hz and 4120/1030Hz, all northern beam.

AsiaSat 2/100.5E: On again - off again. Hainan TV test card on 4133/1017Hz, SR y.032, FEC 3/4.

AsiaSat 3S/105.5E New India service Zee Marathi on 3660/1490Hz, audio 6.6 and 7.2 (Johnson, NZ).

InSat 2E/83E: Jaya TV in PAL analogue now functional on 3597/1553Vt. Vijay TV is at 3555/1595Vt (D. Leach, NSW). DD1-National testing on 3831/1319Vt, SR 6.000, FEC 3/4. DD8-Andhra Pradesh testing 3951/1199Vt, SR 6.000, FEC 3/4, not full time.

JcSat3/128E: A new marginal level (to Australia) MCPC package on 3946/1204Vt, SR 6.110, FEC 3/4 with PowerVu VPID 1160/APID 1120 for Singapore Telecom tests plus two CA channels. NTSC test card on 4085/1065Vt P2 on 3m dish in Auckland (L. Mathews). Revised numbers for Trinity-included MCPC: 3990/1160Vt, SR 13.612, FEC 5/6 (almost as bad as 7/8) with Trinity "Miracle Network" VPID 1360/APID 1320 (yes - that is PowerVu).

Optus B1/160E: Seven Central has appeared on 12.354Vt, SR3.688, FEC 3/4. Network 9 feeds in PAL are found on occasional basis 12.508Hz.

Optus B3/156E: Greek TV (GATV) has replaced Disney and Australian Christian Channel has replaced Odyssey TV on the Optus package (12.564Hz). "PIDs for That 5 (Mediasat bouquet, 12.336Vt) keep changing, apparently to discourage regular viewing or sale of dishes in Australia" (B. Richards).

Palapa C2/113E: C-NET/Space TV channels on 4000/1150Hz are again CA; corrected numbers are SR26.667, FEC 3/4 (A. Mobasher, NZ). "Asian games feeds seen 3720/1430Hz SR 27.295, FEC 3/4" (David Pemberton, Aust.)

PAS2/169E: CMT within California Bouquet FTA as we go to press (3901/1249Hz, SR 30.800, FEC 3/4). "The Golf Channel" has gone from same bouquet, replaced with FTA test card. CNBC advisory of programme channel lineups on PAS-2 (4093/1057Vt, SR 29.473, FEC 3/4): #1-CNBC Regional, #2-CNBC Australia, #3- test bars, #4- CNBC India, #5- test bars,



MediaStar Communications' Jacob Keness at '99 China CATV Show, Beijing, with SatFACTS enthusiast Luo Shi Gang of Shenzhen, PRC.

#6-CNBC Taiwan with part of day subtitling, #7-syndication feeds. Queries to Tina Quah, email tina_quah@cnbcasia.com.sg.

PAS8/166E: All TARBS channels are now CA with rare exception; Mentor Data Systems (Taiwan) IRDs checked for SatFACTS are not capable of being programmed for any other useful purpose. "Digital signal testing 4000/1150Vt, SR6.620, FEC 3/4 - note this was vertical" (David Pemberton, Aust.) "New signal, possibly data, 12.675Hz, much stronger than TARBS" (Bill Richards, Adelaide).

ST1/88E: Nila TV reported off, on in erratic fashion on 3582/1568Vt

Telekom/108E: Tests underway from temporary 122.5E location, carriers reported 4120/1030Hz and 4140/1010Vt. This satellite due to replace B2R at 108E mid-October.

Thaicom 3/ 78E: ITC/Infochannel active on 3569/1581H, SR 13.330, FEC 3/4 (B. Richards). Skai-TV on 3423/1727Hz, SR 3.366, FEC 2/3 (D. Leach, NSW). JAIN-TV tests on 3536/1614Vt replaced by TV India tests. MRTV reported again on 3666/1484Hz, SR 4.442, FEC 2/3. KCTV (North Korea) reported on 3423/1727Hz, SR 3.366, FEC 2/3.

WITH THE OBSERVERS: Reports of new programmers, changes in established programming sources are encouraged from readers throughout the Pacific and Asian regions. Information shared here is an important tool in our ever expanding satellite TV universe. Photos of yourself, your equipment or off-air photos taken from your TV screen are welcomed. TV screen photos: If PAL or SECAM, set camera to f3.5-f5 at 1/15th second with ASA 100 film; for NTSC, change shutter speed to 1/30th. Use no flash, set camera on tripod or hold steady. Alternately submit any VHS speed, format reception directly to SatFACTS and we will photograph for you. Deadline for October 15th issue: October 5 by mail (use form appearing page 34), or 5PM NZT October 6th if by fax to 64-9-406-1083 or Email

skyking@clear.net.nz.

The strange world of contract dish installation

The Australian dish installation world has evolved into a trio of separate activities. The fully independent installer usually offers a "completely installed system" and provides the equipment (major pieces such as IRD, dish as well as small parts) in addition to his labour. There is profit for both. The independent contract installer works on a piece basis, doing the labour portion of installs for equipment sellers who package TRT, European Bouquet, Indian or other systems. This level of install work is generally "piece meal" because sales of such systems seldom achieve a level that will support working 8-5 daily, week in and week out. Finally there is the option of being a "contract installer" on behalf of Austar, or Foxtel. In the case of Foxtel, satellite installs are handled under intermediary contract with Comet Satellite & Cable firm. Installers for Austar and Foxtel depend upon the mass marketing of the firms to create steady work either through new installs or service calls. Installer profits are typically maximised when he assumes responsibility for equipment and installation. This includes the marketing (sale or promotion) of the system and it is here where many would-be satellite business people do not measure up and in fact many people are uncomfortable doing more than the mechanics of the installation work.

When you agree to become a contract installer for a service such as Foxtel, you also agree to play by the rules created by the service. As the equipment does not belong to you (it belongs to the service provider), fairly elaborate paperwork follows to keep track of where each piece of equipment is at all times. This leads to regular "inventory taking" which means you are required to place everything you have out "on consignment" from the service provider into your van for a physical count. The time to do this is typically unpaid, may involve a full Saturday. And you may be required to only use "parts" which have been approved by the service provider. In a 28 August memo, Comet advises contract installers (Augat) "*Snap & Seal connectors are a NON approved part and are not allowed to be installed on any (Foxtel) job site.*" Never mind that Snap & Seal are perhaps the best satellite fittings ever created - "*Any Snap & Seal connectors found to be installed from September 2 onwards will be viewed as a breach of contract and will result in immediate termination of the contract agreement.*" Pretty stiff language for using a "non-approved connector," especially when the "approved" connector uses a hex crimp format notoriously susceptible to moisture ingress. It gets more intimidating. A September 3rd bulletin warns that monetary fines up to \$150 will be assessed against contract installers for work not done in a timely fashion nor to (Comet) standards. An example? A \$20 fine for not using a drop sheet, a \$50 fine for "Insufficient clean up at job site." Sometimes being in business for yourself is not such a bad option after all.

ADI MediaMate

Digital Satellite Receiver

**SPECIAL
INTRODUCTORY
PRICE** INCLUDES TAX

**ONLY
\$695**

CALL FOR EXPORT \$\$\$

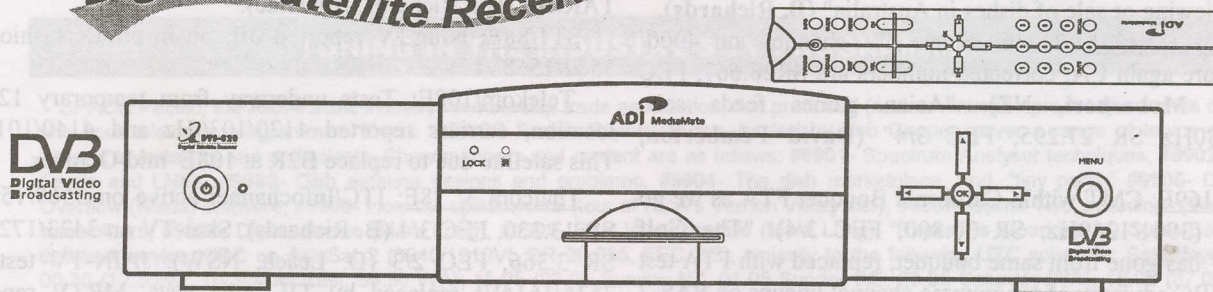

- Low Threshold Performance
- Easy to use Graphic Interface
- 2 - 32 Msymbols (FTA Power View)
- NTSC & PAL Outputs
- 22Khz / DiSeQ / 12VDC Aux
- Teletext Output in Video
- 90 - 264 VAC 47 - 63 Hz Power supply
- 27 / 36 Mhz Tuner
- PID Menu
- RS232 Computer Control & Software Download

Also Available 1.8m & 2.4m Solid Steel Dishes & MTI Dual Pol C Band LNBFs

Pacific Digital Systems Pty Ltd Ph. 61 2 8765 0270 Fax. 61 2 8765 0275

EXCLUSIVE AUSTRALIAN, NEW ZEALAND, PACIFIC ISLANDS DISTRIBUTOR

Recent Transponder Changes - Summary

AsiaSat 2/100.5E: 4133/1017Vt, Hainan TV test, SR 7.032, FEC 3/4 (new)

AsiaSat 3/105.5E: 3660/1490Hz Zee Marathi (new)

ApStar 1/138E: 3885/1265Vt, Macau TV, SR4.444, FEC 3/4 (new)

JcSat 3/128E: 3990/1160Vt, MCPC including TBN, SR12.997, FEC 5/6 (revision)

Optus B1/160E: 12.354Vt, Central 7, SR3.688, FEC 3/4 (new)

Optus B1/160E: 12.256Vt, ABC NT feed, SR5.026, FEC 3/4 (new)

Thaicom 3/78.5E: 3569/1546Hz., Info TV, SR13.330, FEC 3/4 (revision)

Thaicom 3/78.5E: 3423/1727Hz., Skai-TV, SR3.366, FEC 2/3 (revision)

Letter from Gregory Hermosa in Oman

"Upon returning from a month long holiday at home (Philippines), I find new activity on several satellites which also reach the eastern Asia and Pacific regions. On my 2m solid dish with 20 degree LNB and M60e analogue receiver:

Thaicom 3/78E: 3640/1510V, Test (P4); 3616/1534V, ETN (P4); 3583/1567V, ATN (P4); 3558/1592V, RAJ (P4); 3537/1613V, JAIN-TV (P5); 3515/1635V, RAJ News (P5); 3480/1670V, Lashkara (P3). InSat 2E/83E: 3563/1587V, Vijay (P5); 3600/1550V, Java-TV (P5); 3650/1500V, Asianet (P5); 3812/1338V, DD1 Tamil (P4); 3855/1295V, DD1 National (P5); 3930V/1220V, DD2 Metro (P5); 3965/1185V,

The Launch Pad

KoreaSat 3 to 116E, 16 Ku replacing Ks1; launched September 4.

NSS-K to 95E, 30 HP Ku; delayed to June 2000

InSat 3A, no date certain, will go to 83E

AsiaSat L-band radio (1452-1492) to 105E, rescheduled to November

Commentary:

Many launches previously scheduled for later 1999 and first half of 2000 have been delayed, some indefinitely. There is a slowdown in launch activities, a partial result of failures (example: Orion 3) and some because of a recognition that satellite transponder capacity now exceeds demand in the Asia-Pacific region.

DD8 Telugu (P4); 4094/1056V, DD7 Bangla (P3). ST1/88E: 3590/1560V, Nila-TV (P5+++). "

Letter from Steffen Holzt in New Caledonia

"Regarding satfacts-daily Web site comments on Benjamin DB6000 IRDs. Have imported around 45 of these to date, no failures, good performance. Conversely, of 10 SA IRDs, 4 are stuffed and 2 are beyond repair."

AUSTRALIAN?

Av-Comm Pty Ltd. has the "best" service for subscriptions to SatFACTS Monthly and Coop's Technology Digest!

Tel 02-9949-7417 or

Email [cgarry@avcomm.com.au](mailto:cgary@avcomm.com.au)

Proudly a sponsor of SPACE Pacific Report!

JACOBSON'S

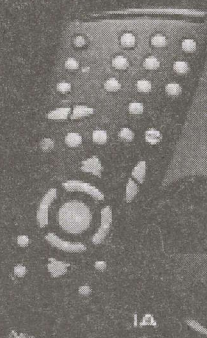

THE NEW GENERATION OF DIGITAL
SAT. RECEIVER IS HERE!
НОВОЕ ПОКОЛЕНИЕ ЦИФРОВЫХ СПУТНИКОВЫХ
РЕСИВЕРОВ!
9800S

UNIQUE HIGHLY INTEGRATED ONE-CHIP SOLUTION WITH A TEN TIMES BETTER
PROCESS CAPACITY....

MAKE SURE YOU BUY THE BEST! ASK US WHERE YOU CAN GET IT!

УНИКАЛЬНОЕ ВЫСОКОИНТЕГРИРОВАННОЕ РЕШЕНИЕ С ДЕСЯТИКРАТНЫМ
УВЕЛИЧЕНИЕМ СКОРОСТИ ОБРАБОТКИ ИНФОРМАЦИИ....

БУДЬТЕ УВЕРЕНЫ - ВЫ ПОКУПАЕТЕ ЛУЧШЕЕ!

СПРОСИТЕ НАС, ГДЕ ВЫ МОЖЕТЕ ЭТО ПРИОБРЕСТИ!

NOKIA

Receiving Equipment
Direct to home

EMITOR AB

Test equipment
and accessories

316

Digital cable-TV head
equipment
and Microwave link

ELCON

Multi switches

SMW

Digital professional L

Channel Master

Satellite Antenna

JACOBSON'S, авторизованный дистрибьютор в следующих странах: Россия, Беларусь, Украина, Молдова, Грузия, Армения, Азербайджан, Казахстан, Туркмения, Киргизия, Таджикистан, Эстония, Латвия и Литва.

Nedralid S ■ 59197 Motala ■ SWEDEN ■ Phone: +46 141 220 331 ■ Fax: +46 141 220 111 ■ Website: www.jacobsons-t.se ■ E-mail: info@jacobsons-t.se
Москва, Ленинградская область ■ Tel: +46 141 220 060 ■ Mob: +46 706 80 06 24 ■ Ask us for catalogue!

AT

Sign-off

Law - at last

On September 2, Australia's Attorney-General Daryl Williams asked the House to consider 'Copyright Amendment (Digital Agenda) Bill 1999'. Simultaneous to the introduction, a press campaign distributed stories headlined "Pay TV piracy to be outlawed." The AAP story, intended for newspapers, got scant attention. There are some quotes worth repeating:

"The reforms will update Australia's copyright standards to meet the challenges posed by rapid developments in communications technology. It will outlaw the manufacture, import or distribution of devices to allow for the unauthorised reception of pay television services. Such devices include decoders which allow the unauthorised viewing of pay TV signals. These provisions will enable subscription broadcasters to control the reception of their encoded broadcasts."

As we go to press, the proposed legislation has gone only to the House of Representatives. You can access the 75 page document by going to Internet, entering <http://www.aph.gov.au> and then selecting the "House Bills" detail looking for the (Digital Agenda) line entry. What is ahead is passage of the legislation by the house, introduction into the Senate, passage by the Senate. And then, a six month moratorium which is described as, "a period of time to allow the industries affected to adjust to the new law."

The proposed legislation is not a new law, rather it is an amendment to the last complete Copyright Act - dated 1968. What the proposed law seems to verify is that it is not - today - illegal to manufacture nor distribute piracy smart cards or decoders in Australia.

In fact, it is probably well known in serious piracy circles that Australia remains - for the moment at least - an "island" where piracy activities can be conducted quite openly without fear of prosecution. One glaring example of this is found on Internet (<http://www.gladiatorstestcards.com>) where a USA firm offers "test cards" for the USA satellite pay-TV DSS and DISH services. For US\$600 this European origin group offers to provide smart cards which they claim will decode all 200-plus DSS or DISH channels including pay-per-view. And the Australian connection? They offer "live interaction with an agent" to anyone dialling a number that begins with 61-2-9475 (XXXX). Yes, that appears to be a Sydney number! They also provide an email address and a caveat about the "time zone differences between the USA and the live agent."

Actually, fronting for American piracy cards in Australia (or elsewhere outside of the USA) is a common practice for piracy card suppliers. For example, pick up *What Satellite* (the highly regarded English publication) and you will find page after page of four colour advertisements for cards and decoders. But all are for devices intended to open up non-British channels - a method of "getting around" the British law that would close them down instantly if they openly advertised UK pay-TV piracy products. Then open up a copy of Germany's

ALIEN 3 auto upgrading card	only £69
ALIEN 4 auto upgrading card	only £89
HORNET digital cards you choose the package	only £179
HUMAX P1000 digital receiver with built in and twin common interface	
PLAYSTATION cheat	
PLAYSTATION	
PICBUSTER & EEPROM PROGRAMMER - Avoid paying costly upgrade fees	
with our easy to use programmer.	
€ Programs Wafer and Chip Cards € Built-in Card Reader	£45
€ Programs 24Cxx Eeproms € inc PSU € Software	MEGA-DU
STEALTH MULTI-PICBUSTER - As above plus the ability to programme a wider range of chips, e.g. 12C508, 16C622 etc.	£55
STEALTH SMARTMOUSE - Popular programmer for updating MAC and Digi Cards. Standard 3.5 MHz Version	
STEALTH SMARTMOUSE PRO - Switchable 3.5 and 6MHz Version	
STEALTH PC TO DECODER INTERFACE - Enables your PC to view D2-MAC viewing card	
STEALTH PC TO DECODER INTERFACE - Enables your PC to view D2-MAC viewing card	
FACE - Reprogramme your NOKIA Box with new NVB2000	
1 CHIP PCB WITH DILL SOCKET	ONLY £0.25

Tele-Satellit and here you will find advertisements for devices intended to grant access to *British* pay-TV services! Of course you don't have to hold a British magazine in your hands in Germany or a copy of Tele-Satellit in the UK to locate piracy device sources. Internet flows world-wide and reaches everyone no matter where they might be.

The proposed new law, Part V, paragraph 116A makes it an offence to:

- (i) make a circumvention device capable of circumventing, or facilitating the circumvention of, the effective technological protection measure;
- (ii) sell, let for hire, or by way of trade offer or expose for sale, or hire, any such circumvention device;
- (iii) distributes such a circumvention device for the purpose of trade, or for any other purpose that will affect prejudicially the owner of the copyright;
- (iv) exhibits such a circumvention device in public by way of trade;
- (v) import such a circumvention device into Australia"

These are all reasonable, good, needed first steps to curtail piracy. The law allows six years from the date of any offending act for prosecution to be brought - although acts committed prior to adoption of the law are not punishable (indeed, if they were, there would be no need for the new revised law). Penalties include up to five years in prison and fines up to 550 penalty units.

Contrary to initial reports, the proposed law does not deal solely with piracy for pay-TV. In fact, this attracts only a small portion of the revisions. Also included in the changes - a procedure that will allow terrestrial free to air broadcasters to extract a fee from pay-TV operators (cable systems, for example) transmitting the FTA services to subscribers. And newly defined regulations to protect copyrighted computer software programs or "digital watermarks" inserted onto or within copyrighted material as a method of tracing illegal copies of virtually anything. Libraries with copying machines will be affected, so too any business that makes a copy machine available to the public for a per use fee.

That a new law affecting so many people and businesses will slide through Parliament without attracting opposition is questionable. Or, that piracy will suddenly stop anytime soon is debatable.

THE 1999 SATELLITE EXPLOSION IN THE PACIFIC/ASIA!

SatFACTS with this issue begins year six!
Stay tuned with SatFACTS!

- ENTER my 12 MONTH subscription to SatFACTS starting with October 15th issue (rates below)
 ENTER my 36 MONTH subscription to SatFACTS starting with October 15th issue (rates below)

NAME _____
Company (if applicable) _____
Mailing address _____
Town/city _____ Country _____

Amount to send: 1 year - NZ\$60 (inside New Zealand) / A\$96 (inside Australia) / US\$60 (outside of NZ and Australia) or 3 years - NZ\$140 / A\$220 / US\$150 if by cheque. **VISA** or **Mastercard**? See form below and return with order. Return to: **SatFACTS, PO Box 330, Mangonui, Far North, New Zealand** or if by VISA or Mastercard fax to 64-9-406-1083

IF YOU ARE IN AUSTRALIA - See AV-COMM Pty Ltd Advert p. 31!

USE THIS FORM ONLY WHEN CHARGING ON VISA/MASTERCARD

Please charge my **VISA/Mastercard** as follows:

- ONE Year of SatFACTS MONTHLY (NZ\$60, A\$96, US\$60)
 THREE Years of SatFACTS MONTHLY (NZ\$140, A\$220, US\$150)
 SATELLITE TELEVISION: The Booklet (NZ\$10, A\$12, US\$10)
 One Year of COOP'S TECHNOLOGY DIGEST (NZ\$125, A\$125, US\$125)
Indicate charge card type: VISA Mastercard

Name (as it appears on **VISA / Mastercard**) _____

VISA/Mastercard Number _____

VISA/Mastercard expiration date _____

Instructions: If ordering by mail, return this complete (3-part) card or a copy of same (to **SatFACTS, PO Box 330, Mangonui, Far North, New Zealand**); if order by FAX, send full card as a single sheet to **64-9-406-1083**

ALL COPIES OF SatFACTS Monthly are sent via Air Parcel Post world-wide!

SUPPLEMENTAL MATERIALS from SatFACTS MONTHLY: Order Form

- SATELLITE TELEVISION:** The Booklet. Excellent introduction to home dish ownership for the layman, including major contributions from the father of geostationary satellites - famed science fiction writer *Arthur C. Clarke*. The perfect tool to help the satellite system seller explain home satellite TV to the layman consumer. From *SPACE Pacific*. NZ\$10/ A\$12 / US\$10, airmail.
- COOP'S TECHNOLOGY DIGEST.** For the really serious enthusiast, investor, business person in satellite television and allied leading edge technologies. Ten issues each year, jam-packed with information you will not find anyplace else. "Coop" routinely culls more than 60 publications world-wide, terribly expensive newsletters, Internet and his hundreds of private contacts to keep you right at the leading edge of technology on the **REAL** changes underway in telecommunications. Conveniently issued near the **first of the month**, creating an excellent time-line-filler between the mid-month issues of SatFACTS. Now in the **6th year**, airmail world-wide. Normally NZ/A/US\$250 per year - for SatFACTS subscribers special **50% discounted** price of NZ/A/US\$125.

OBSERVER REPORTING FORM - Due October 5, 1999

- NEW programming sources seen since August 1st: _____
- Changes (signal level, transponder, programming content) in pre-existing programming sources since August 1st: _____
- OTHER (including changes in your receiving system): _____

NOTE: Please use P1 - P5 code when describing signal levels and receiver IF/RF settings.

Your Name _____

Town/City _____

Make/size dish _____ LNB _____ Receiver _____

Your email address _____ if you have one!

RETURN: SatFACTS, PO Box 330, Mangonui, Far North, NZ, fax 64-9-406-1083, Email Skyking@clear.net.nz

THIS MONTH - WIN A STRONG SRT 170LT ANALOGUE RECEIVER!

This time - there are no "trick" questions. Simply remove this perforated section from SatFACTS, place it into an envelope (no Fax or email entries) and mail to "Strong/SatFACTS, PO Box 330, Mangonui, Far North, New Zealand." On October 15th, staffer Seth Cooper will randomly draw one card from a container holding all entry cards and that person will win the Strong receiver.

Your name _____

Mailing address _____

Town/city _____

Telephone number _____ Email address _____

IS it just a COINCIDENCE
Members of SPACE have more work
than they can handle?



YES - send me information about how joining SPACE Pacific can lead me to more, profitable work!

NAME _____

Company affiliation (if any) _____

Mailing address _____

Town/city _____ postal code _____ Country _____

Sky Vision Australia

A Proudly Australian owned and operated company



SAT CRUISER DSR-101 MPEG 2 DVB / POWER Vu RECEIVER

***Latest Model – New Features
Best value receiver in Australia !***

Trade Price - quoted to established dealers

- √ The ideal consumer orientated receiver with features that will please the enthusiast !
- √ Pre-programmed with all active TP's from Asiasat 2, Palapa, PAS 2 ,PAS 8 and more
- √ 10 spare user defined satellite positions for future satellite launches
- √ Simplified manual TP entry – TP Frequency is the only required parameter !
- √ Auto Symbol rate – Auto FEC – Auto PID's – Auto Polarity (LNBF)
- √ Satellite naming/editing – Channel naming/editing
- √ Alternate audio channels accessible from remote control
- √ On-board NTSC – PAL 50 Hz convertor – compatible with any PAL TV
- √ On-board Digital TELETEXT decoder – no need for Text capable TV
- √ 5 language menu - English (default) Spanish / Italian / French / German
- √ Consumer friendly graphical interface – Easy to install !
- √ UHF Ch 21-69 Software controlled RF Modulator – Low spurious emissions
- √ Low threshold dual bandwidth tuner – Dual SAW filter IF stage
- √ C Tick certified to comply with Australian Communications Authority standards
- √ Ultra reliable SMPS module – not a single reported failure to date !
- √ Full colour photographs and screen shots available from our web site
- √ 12 month replacement warranty – With an optional extended warranty plan
- √ Feel free to call one of our friendly staff for more information !

DSR-201P Analog/Digital/Positioner receiver ..**Trade Price** - *quoted to established dealers*

Export – Wholesale – Trade sales

Web Site: <http://www.bigfoot.com/~skyvision>
E-mail: skyvision@bigfoot.com

Tel: 02 62925850

Fax: 02 62925890

Millennium 2000

Full featured low threshold analog satellite receiver

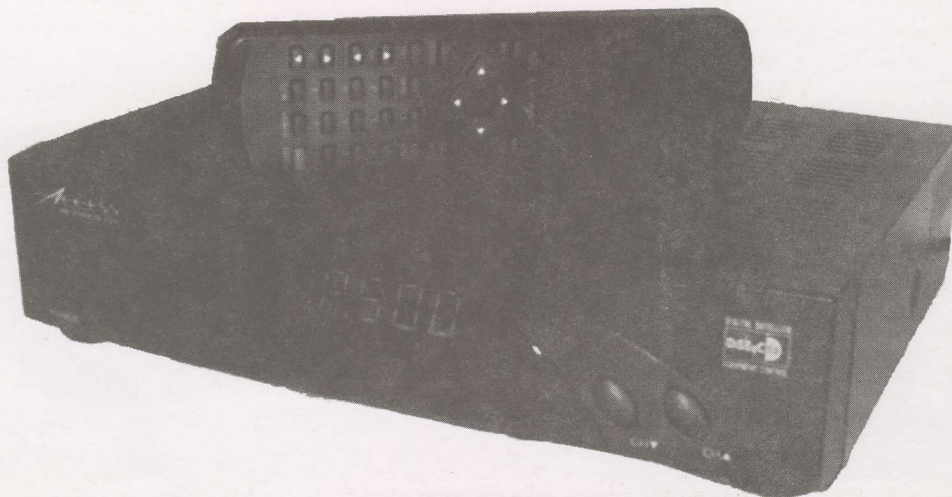

Features:

- On Screen Display 4 Language (English, French, Turkish, Arabic)
- 500 Channels Programmable
- 4 Digit display
- Favorite Channel Function (16 CH)
- Channel Copy Function
- Full Function Remote Control

Video:

- 32 Steps Low Threshold programmable
- Built-In Video Deviation Control Function (4 Steps)
- PAL/MAC/FILTERED/CANAL+ Decoder Interface

Audio:

- Switchable Audio Bandwidth (130/280/330/400KHz)
- 32 Steps Audio Volume Control Adjustable
- Multiple Audio De-Emphasis Control (50 μ SEC/75 μ SEC/J17/Dnr)
- Stereo & Mono all Audio Sub-Carrier (5.00~9.00MHz) receivable
- Panda-1 Compatible HIFI Stereo Super-DNR Sound Systems
- Audio Left & Right Individual Tuning System

Input:

- C/Ku-Band Switchable & Wide Band Tuner 900~2150 MHz
- 2 Input 2 Bandwidth (27/18MHz)
- Down-Link(Transponder) Frequency Direct Tuning System
- LNB L.O.F Select Function (5.150/9.750/10.000/10.750/11.000/11.475GHz & UNI-LNB-HI ,LO)
- L.O.F. Adjustable (+/-15MHz) Function
- Automatic Universal-LNB Control System
- LNB Pulse 22KHz & 60Hz Switching Programmable
- Diseqc 1.0 Built-in
- Multiple LNB control 0/12V Switchable
- Mechanical Polarizer

Output:

- 3-Scart In & Out & VCR Auto Loop Through
- 4-Phone Jack (Video, Audio L/R, Decoder)
- PLL RF Modulator 21 ~ 69 CH
- RGB D2-MAC Scart Interface Connection

Power:

- Switching Mode Power Supply (90 ~ 260VAC)

Dimensions:

- Small Chassis (280 X 200 X 65mm)

These quality products distributed by:



Phone: +61 8 9306 3738 Fax: +61 8 9306 3737
sales@sciteq.com.au <http://www.sciteq.com.au>