

13-8-99 - 9AM

Bob Cooper's

AUGUST 15 1999

# SatFACTS

MONTHLY

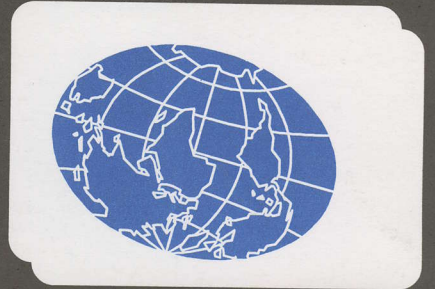

Reporting on "The World" of satellite television in the Pacific and Asia

## IN THIS ISSUE

**TRT-tanic  
threatens to sink  
industry!**

**God arrives,  
French porno  
demonstrating**

**Broadcasting  
Services  
Amendment Bill**

- ✓ Latest Programmer News
- ✓ Latest Hardware News
- ✓ Latest SPACE Pacific Reports
- ✓ Cable TV Connection

Vol. 5 ♦ No. 60  
Price Per Copy:  
NZ\$9/A\$10/US\$7



# Paraclipse<sup>®</sup>

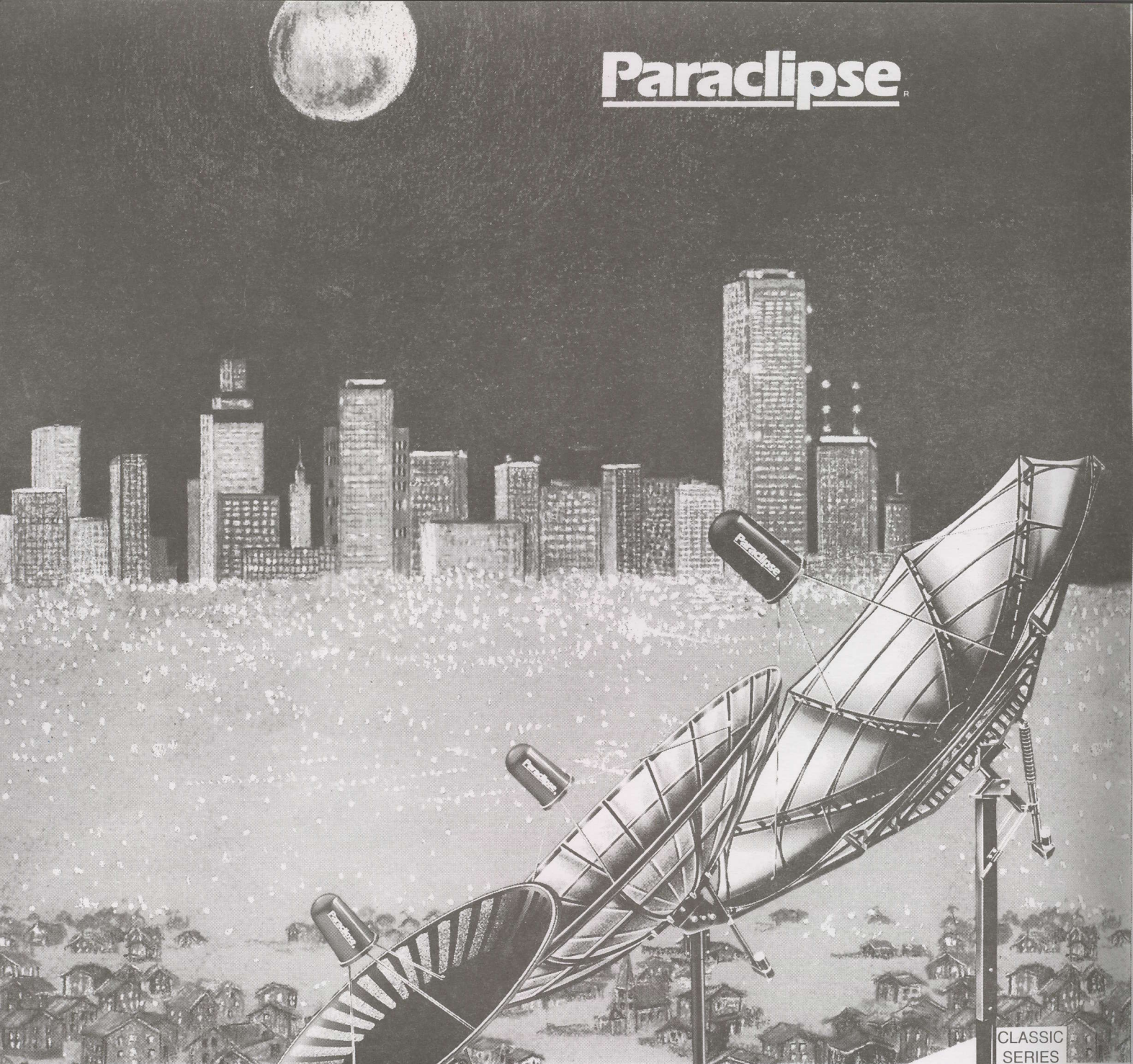

CLASSIC  
SERIES

ECLIPSE  
SERIES

Distributed in Australia & the Pacific by

When quality, strength, and accuracy are your main requirements, **Paraclipse** antennas are your first choice.

HYDRO  
SERIES

Only **Paraclipse** offers such variety; four distinctly different series: the Truss-Ribbed Classic, the Courier Deliverable Eclipse, the Stretch Formed Hydro, the Commercial Patriot.

Every **Paraclipse** model sets the industry standard in its class, worldwide.

**SATECH Satellite  
Communication  
Technology Pty. Ltd.**

18/477 Warrigal Rd, Moorabbin  
East, Victoria, Australia 3189  
tel 61-3-9553-3399  
fax 61-3-9553-3393

**Paraclipse<sup>®</sup>**  
HIGH PERFORMANCE ANTENNAS

★ **MADE IN  
AMERICA**

Paraclipse Inc.  
2271 29th Avenue East, Columbus, Nebraska USA 68601  
Telephone: (402) 563-3625 Fax: (402) 564-2109

# SPACE PACIFIC REFERENCE MATERIALS

(updated August 15, 1999)

to help you do a better job, profitably

Some items in limited quantity (marked LtdQty); many have special SPACE member discounts

## SPACE Pacific Report (the TV show)

The television programme, direct to you from digital master on E240 VHS tape, PAL format of course. Show 9901: "It is your signal, too" and "Fun and games with the spectrum analyser." Show 9902: "Feeds and LNBS" - understanding how products differ. And, "Mark Long's Thumbnail History of home satellite TV" featuring the real pioneers of the 70s and 80s! Show 9903: "Dish antenna critique," why some dishes work better than others, plus Mark Long on installing your own dish, and, Richard Brooks on PVRs. Show 9904: "Who buys DTH systems?" explores the marketplace, plus, "Understanding Tiny Parts" looks at connectors, line-amps and splitters. Four hours as currently running on KIBC, SPN - digital mastered to you for the exceptional price of \$55 including shipping and two bonus items - "Satellite Television (The Booklet)" featuring material by Sir Arthur C. Clarke, and, the infamous CMT satellite pencil-writer! (see order form, below). In stock, shipped within 72 hours. (No SPACE discount)

## The Wireless Primer

Now that TARBS has turned the ex-Galaxy MDS/MMDS system back on in Australia, this is "the book" that explains to you just how this service works. From top to bottom. Extensive references, real-world hardware, service challenges and solutions. Written by the acknowledged "Dean" of MDS/MMDS world-wide, the late Glyn Bostick of Communications & Energy Corporation, Syracuse, NY. Be quick - this is a limited quantity (LtdQty) item at \$20 per copy (SPACE Member discounts apply).

## World Sat TV '96

If you are new to satellite TV, are not sure about the difference between the LNB and LNBF, or what vertical and horizontal means - this is the self-learning book for you. Written by Mark Long, it takes you from total novice to satellite expert in 13 well illustrated, carefully explained chapters. Originally written for Asia & Middle East, this 1996 version heavily discounted at \$15 (LtdQty); SPACE discount applies.

## World Sat TV '92

Essentially the same book as World Sat TV '96 but released four-years earlier. All of the basic fundamentals are here, at a price that is too good to be true. Hey - the quantity is very limited (LtdQty) and we need to clear out the shelf space. \$10 and if you are a SPACE Member, it comes down 30% to \$7! Having a complete satellite TV reference book doesn't get any cheaper than this.

## TB 9404 DTH Systems

Direct to Home: Satellite System Installation Techniques. Without question, the very best quick tutorial on what a home dish system is, how it works, where the problems develop. If you are new to the DTH field, buy this and commit it to memory. Very slight New Zealand bias, not enough to hurt its value world-wide. Prepared by Coop for an Asian DTH technology conference, LtdQty \$10 (SPACE discount).

## TB 9405 SMATV Systems

Satellite to room - Commercial SMATV (Satellite) Dish Installations. The easy part is the satellite dish or dishes. The difficult challenge is getting all of those signals - including the terrestrials - balanced and into every room and each TV outlet at the proper level. If you plan to do multiple-outlet systems, start here with this Coop written tutorial. LtdQty and only \$10 per copy while they last! (SPACE discount)

## Nelson Parabolic Manual

The Nelson Parabolic TVRO Manual. If you are the type of person who wants to build your own dish (up to 3.7m in size), or, you simply want to understand why some dishes work better than others, this step-by-step "how to build a dish" manual is the "Bible" of an industry. Nelson Ethier was a perfectionist and brilliant with hand tools. It shows here - the ultimate backyard project! Half original price at \$15, LtdQty, SPACE discount applies.

## SPACE Pacific Order Form (also see SPECIAL PACKAGES on reverse side)

Please send the following:

SPACE Pacific Report - The TV Show/ \$55 (no discount);  The Wireless Primer/ \$15;  World of Sat TV-'96/\$15;  World Sat TV-'92/\$10;  TB 9404 - DTH Systems/\$10;  TB 9405 - SMATV Systems/\$10;  Nelson Parabolic TVRO Manual/\$15. Total of order - \$ \_\_\_\_\_. If current SPACE member, multiply by 0.7 (70%) and write discounted total here: \$ \_\_\_\_\_

I wish to pay this by  cheque (enclosed)  VISA card  Mastercard  
Card number \_\_\_\_\_ expires \_\_\_\_/\_\_\_\_

Ship to (name as it appears on card):

Company \_\_\_\_\_

Mailing address \_\_\_\_\_

Town/city \_\_\_\_\_

Your signature: \_\_\_\_\_

Return to: SPACE Pacific, PO Box 30, Mangonui, Far North, New Zealand or fax 64-9-406-1083

# SPACE Pacific Terrestrial TV Reference Materials

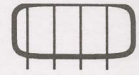
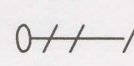
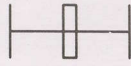
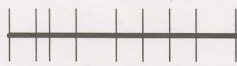

Each of these editions researched, created by "Coop" to help you solve tough aerial problems

<b>TB 9301</b>	<b>Tech Bulletin 9301. Co-Channel &amp; Antenna Phasing.</b> How to grow a single antenna (Yagi, broadband antenna) into a complex array to greatly increase gain, sharpen receiving pattern to eliminate co (same) channel interference. Totally hands-on, very practical, up-to-date. Go from novice to professional!
<b>TB 9302</b>	<b>Tech Bulletin 9302. Weak Signal Reception Techniques.</b> If one cut-to-channel (Yagi) antenna won't do the job, will 2, 4 or 8??? How about 16? Stacking antennas, mating with carefully selected masthead amps, is an art. This explains how to do it for professional results up to 300 km from TV stations.
<b>TB 9303</b>	<b>Tech Bulletin 9303. UHF - The Frontier.</b> Using parabolic style antennas surfaced with low-cost poultry mesh, build UHF dishes up to 40 feet in size to extend UHF off-air reception out to 300 km. And - learn the tricks to "squirt" signals from a hilltop to a valley below using low-cost receiving equipment.
<b>TB 9304</b>	<b>Tech Bulletin 9304. Beating Noise Interference &amp; Combining Cross-Pole Signals.</b> When TV and FM signals are weak, man-made interference from appliances, power lines can kill reception. Step-by-step instruction for identifying, locating, fixing noise sources + unique method of combining cross-pole TV signals.
<b>TB 9305</b>	<b>Tech Bulletin 9305. Cable Television - Fact &amp; Fiction.</b> The story of how a cable TV system is designed, built, operated. The perfect "So this is how it works!" report. Who knows - you might even like the concept so well you take out a mortgage on your home and wire your town!
<b>Lost Art</b>	<b>Lost Art of Rhombic Antennas -27 dB of gain VHF &amp; UHF.</b> Everything you need to know to build the most sensitive VHF-UHF receiving antenna ever created. Rhombics are used for virtually all long haul military circuits. Includes super-Rhombic LaPorte design. 300 km? A piece of cake!
<b>40' Dishes</b>	<b>20 to 40' Poultry Mesh (Chicken Wire) Parabolics.</b> Complete instructions to build UHF-TV off-air reception antenna system combines low cost reflector materials with Redwood or other durable "struts." 20 to 25 dB of gain, out to 300 km UHF reception. A backyard project with earnings potential.
<b>Half-Bolics</b>	<b>World-Famous Frias Half-Bolic Reflector.</b> Amazing design allows simultaneous reception over sizeable arc of transmission locations. City grade (80 dBuV) reception from distances of 280 km on VHF (45 MHz) through UHF (900 MHz). This is huge, but easily the best all-around deep-deep fringe antenna system.
<b>Raw Video</b>	<b>SPRSCS '99.</b> SPACE shot many hours of video during SPRSCS '99 to prepare for the (now available) 9901 - 9904 one-hour TV shows. In "Raw Video" you have everything shot, <u>before</u> editing, including material done by Robin Colquhoun for the Dr Overflow software explanation - still not edited into a TV show. 4 hours, PAL.

## ORDER FORM - and special discount packages

Please send the following:

- TB 9301/\$10;  TB 9302/\$10;  TB 9303/\$10;  TB 9304/\$10;  TB 9305/\$10;  Lost Art-Rhombic/\$20;  20-40' Dishes/\$20;  Frias Half-Bolic/\$20 - or  
 TB9301/9302/9303/9304/9305 - \$40 -or-  Rhombic/ 20-40' Dishes/ Half Bolics - \$50 -or-  
 TB9301/9302/9303/9304/9305 + Rhombic/20-40' Dishes/Half Bolics - \$80.

**Video:**  Space Raw Video/\$35;  SPACE Pacific Report (see top, first side) + Space Raw Video/\$85. Total of order - \$ \_\_\_\_\_; If current SPACE member, multiply total by 0.7 to obtain discount price (NOTE: No discount applies to Raw Video or SPACE Pacific Report) - new discount total \$ \_\_\_\_\_. I wish to pay this by  Cheque (enclosed)  VISA  Mastercard

Card number \_\_\_\_\_ - \_\_\_\_\_ - \_\_\_\_\_ - \_\_\_\_\_ expires \_\_\_\_/\_\_\_\_

Ship to (name as it appears on card)

\_\_\_\_\_ Company \_\_\_\_\_

Mailing address \_\_\_\_\_

Town/city \_\_\_\_\_

your signature \_\_\_\_\_

Return to: SPACE Pacific, PO Box 30, Mangonui, Far North, New Zealand or fax to 64-9-406-1083

# SatFACTS MONTHLY

ISSN 1174-0779

is published 12 times each year (on or about the 15th of each month) by Far North Cablevision, Ltd.

This publication is dedicated to the premise that as we enter the 21st century, ancient 20th century notions concerning borders and boundaries no long define a person's horizon. In the air, all around you, are microwave signals carrying messages of entertainment, information and education.

These messages are available to anyone willing to install the appropriate receiving equipment and, where applicable, pay a monthly or annual fee to receive the content of these messages in the privacy of their own home. Welcome to the 21st century - a world without borders, a world without boundaries.

## Editor/Publisher

Robert B. Cooper (ZL4AAA)

## Office Manager

Gay V. Cooper (ZL1GG)

## Reaching SatFACTS

Tel: 64-9-406-0651

Fax: 64-9-406-1083

Mail: PO Box 330

Mangonui, Far North

New Zealand

Email -Skyking@clear.net.nz

<http://www.satfacts.kwikkopy.co.nz>

## Subscription Rates

Within NZ: \$60 p/y

Australia: AV-COMM Pty Ltd, PO Box

225, Balgowlah, NSW 2093

61-2-9949-7417

Elsewhere: US\$60 p/y

All copies sent via airmail fast post world-wide

## ERRATA

SatFACTS Copyright 1999 by Robert B. Cooper; any form of copying is a violation of our international copyrights. Advertising rate sheet available upon request.

## COOP'S COMMENT

Buried deeply within the current Australian Government plan to sell off a piece of national telecommunication provider Telstra is a "bone" for the television world; A\$120 million to be spent in fixing what the bureaucrats label "Black Spots" - areas where terrestrial TV reception is poor or impossible. In a paper created to support the hoped for passage of (the) Broadcasting Services Amendment Bill (1999), the Department of Communications, Information Technology and the Arts tells us how Government plans to implement "black spot" eradication.

"Television Fund - Issues Paper" suggests (and I quote) "The black spots program will require a 'decision-maker' whose key responsibility will be to make final determinations on which applications will be approved and funded. Applications (for funding) would be assessed against guidelines developed in consultation with industry and community groups."

The very next paragraph says, " An independent Board will be appointed by the Minister to perform the 'decision-maker' role. Although, the Minister will appoint the members of the Board and approve the guidelines for assessing black spots applications, he/she will have no involvement in determining which projects are to be funded under the black spots program."

The first quotation says "a decision-maker's key responsibility will be determining which applications will be funded" while the second says "he/she (presumably the Minister) will have no involvement in determining which projects are to be funded." Unfortunately, most of the Issues Paper reads as if it were written by a committee with widely divergent views only a paragraph removed. The section devoted to explaining how a single home with poor or no quality terrestrial TV reception will gain ABA approval to access Central 7, Imparja, WIN or GWN provides very little comfort. Common sense tells me that if a home is willing to lay \$1,500 on the line to purchase a satellite receiving system just to gain access to one or two of the satellite delivered "super stations," the real decision has already been made. A home with \$700 invested in a TV set and half that again already spent - *with no result* - in a rooftop aerial and mast does not rush out on a whim and agree to spend \$1,500 to get Central 7 and/or Imparja. They must really get bad (or no) terrestrial reception to have made the \$1,500 satellite decision. And no amount of bureaucratic fine tuning by the ABA should derail that decision. *Who* is better to judge whether existing TV reception is too poor to watch than the people who *live* at the intended location for the satellite dish? Can the ABA do a better job of deciding how good or bad the reception really is from a desk in Canberra?

The Television Fund paper strongly suggests that an entirely new level of bureaucracy, and meddling in people's lives, is the ransom the ABA demands to "approve" individual DTH installations. We are betting the "person responsible" for approving or denying individual applications will not be available by telephone, will not have an e-mail address, and won't answer letters. We are further betting everything possible will be done to disguise who this person is, or to explain how he/she does the assigned job. It will be frustrating to those who have to sell and install DTH terminals, to the consumers who have made the only decision that really counts (spending \$1,500) and will slow down the wheels of commerce without offsetting benefits. There must be a better way to do this.

## In Volume 5 ♦ Number 60

TRT provokes "Boom Town" and "Bust" mentality -p. 6

TBN Religion is new viewing / selling opportunity -p. 10

French fire latest pay-TV missile to 142.5E -p. 12

Broadcasting Services Amendment Bill challenges Australia -p. 14

## Departments

Programmer/Programming Update -p.2; Hardware/Equipment Update -p. 4;

SPACE Pacific Report (life in the political lane) -p. 20;

Cable Connection (problems in digital terrestrial world) - p. 22; SatFACTS Digital Watch -p. 24;

Supplemental Digital Data -p. 26; SatFACTS Analogue Watch -p. 27; With The Observers -p. 29;

At Sign-Off (how thin our line really is) -p. 32

## -ON THE COVER-

TRT. Under 1m coverage via Optus B3 to Australia AND New Zealand. (p. 6).



August 15, 1999

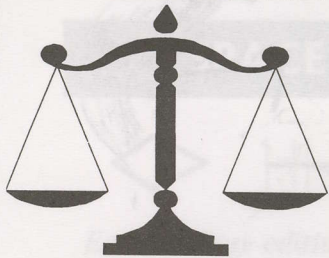

L  
E  
T  
T  
E  
R  
S

Condom on the cover

"My wife thought it was a pacifier which small children sometimes use."

LM, NZ

"Prophetic prophylactic prophesy. Phooey!"

RLD, Victoria

"Do I have your permission to refer people to SatFACTS July 15th for everything they need to know about smart card splitters?"

MadMax, South Africa

"OK - I give up. After months of telling myself there was nothing useful to learn here, I have ordered an MK-13 which arrives tomorrow."

SMM, NZ

"The guy who was found hanging from a tree outside his home in Germany was a nice, quiet, devoted fellow who loved his hacking just a little bit too much. He was a friend and I miss him."

DO, Europe

"If those damned cards are so great, why did I feel like I was committing a terrible act when I sent off two ex-Galaxy cards to South Africa (which were promptly replaced with one very nicely working MOSC)?"

PTY, Qld

"I think you got the attention of the authorities at Foxtel and suggest you lay off the subject of hacked cards for awhile."

PC, NSW

"So now the lid is off, how long before the poison soaks into our water supply and we all die?"

AZT, WA

"You may cancel my subscription immediately. I don't care if everyone else in Australia is hacking, I don't want this trash in my house. I love my Foxtel and willingly pay for it!"

GD, Qld

"After I read this report, I thought hackers were strange people with social problems. I went to visit a friend with a dish, noticed SatFACTS on his table and asked him about it. He smiled and pulled a cloth off a table under which he had card splitters and a computer running full-time. I would never have guessed his interest or talents. Now I am really upset - hackers are just people, like you and me!"

HL, Sydney

"Your editorial was correct - it did upset me. Then I spent a few hours in a library researching the status of Australian law concerning things like smart cards. And you know what? It is a wonder that people aren't hacking telephone cards and the like - the law here is decades behind technology. If Foxtel and Austar want this to stop - the first thing they should do is get some current legislation adopted."

LSS, Melbourne

Surprise. Telephone cards are hacked - with MK13s.

PROGRAMMER  
PROGRAMMING  
PROMOTION

UPDATE

AUGUST 15, 1999

**Arirang TV** went to full 24 hour schedule August 12 featuring 30% English audio and 70% English subtitles. Service is on AsiaSat 3, FTA MPEG-2 DVB compliant, available for home, SMATV and cable systems.

◆ Arirang TV's Technical Information ◆  
 Satellite: Asiasat 3S C-Band  
 Color System: PAL Standard  
 Transmission: MPEG2/DVB Free-To-Air  
 Type of Access: SCPC  
 FEC Rate: 7/8  
 Downlink Polarization: Vertical  
 Frequency: 3755.15 MHz  
 Symbol Rate: 4.4179

**SPN** - Sports Pacific Network out of Nauru (I1701, 180E), signed off the air with an abrupt notice July 5 and notified cable and broadcast stations "We expect to be off for about one month while doing some work on our uplink." Attempts to get a concise answer concerning when service expects to resume have been unproductive at press deadline.

**TBN** - Trinity Broadcasting Network, new on I1701, will - under "certain conditions" - provide "free digital receiver to cable and SMATV affiliates" in Pacific and Asia. First check out the service (3765/1385RHC, SR 29.900, FEC 7/8 - yes, that is a killer - programme channel 3) and then contact Ben Miller as [bmiller@tbn.org](mailto:bmiller@tbn.org).

**Astra**, a trade organisation of pay-TV providers in Australia, has imported Carter Elzoth from European anti-piracy trade association AEPOC to meet with Members of Parliament and their aides - purpose? To explain first hand the steps being taken in Europe to identify, control or shut down "piracy card suppliers" there. Astra is urging Parliament to amend existing laws which they admit are totally out of date and "inadequate" to deal with threat of pay-TV piracy in Australia. If you have ever wondered why there have not been highly visible court cases charging piracy in Australia the answer is unfortunately that attorneys advise such cases would most likely be lost if those accused of piracy have adequate defence attorneys.

"Adequate?" Meaning, "Anyone who researches the present law realises that card piracy is probably not a crime at this time." AEPOC has had modest success shutting down card piracy in select European countries but only at the "street vendor" level. The manufacturers keep moving further and further east into what was part of the USSR years ago. Bulgaria is presently center of major DPSC (digital pirate smart card) manufacturing operations. And because pirates can pack everything they need into the boot of a compact vehicle, these guys are very difficult to catch even with the (rare) assistance of eastern European police agencies. Astra is managed by Debra Richards who can be reached [richardd@astra.org.au](mailto:richardd@astra.org.au).

**Members only club.** Annual "meeting" of leading card hackers in world scheduled for late August in small German town. At least one member of "press" has been invited (no - not us! Dr. something-or-rather from Holland) to join with regular attendees such as Cuba Libre, Dr Ice, AlBundy, Snoopy, Sandokan and more. Wouldn't you like to be a fly on the wall as they discuss the latest in card technology? Wouldn't Mindport love to buy a transcript of the discussions!

**www.  
skandia.  
com.  
au**

Skandia Electronics Pty Ltd  
183 Burwood Rd  
Hawthorn 3122  
Tel: (03) 9819 2466  
Fax: (03) 9819 4281  
Email: [skandia@skandia.com.au](mailto:skandia@skandia.com.au)  
Website: [www.skandia.com.au](http://www.skandia.com.au)

### Serious stuff

"I was more curious than serious when ordering the SPACE Pacific 'Deep-Deep Fringe Aerialist Engineering data'. Wow! Double WOW!! It really is possible, even practical, to haul terrestrial TV (and FM) signals over 300 km paths with sufficient quality to satisfy most viewers. The Rhombic and Frias-Half Bolic plans are superb, very well done. And the Surface Wave Logi looks like a perfect winter-type shop project. I had no idea this sort of technology existed - thank you for making it available!"

LJ Joiner, (extreme) northern Queensland

This super-antenna technology was developed in the early 1950s in North America. For most of us, large, finely tuned, sensitive antennas for terrestrial VHF - UHF reception are outmoded because of the ready availability of satellite signals. But there are many sections of Australia (and elsewhere) that only have a partial TV service with the nearest alternate networks outlets well beyond reach of "normal" antenna systems. Here is something to think about - the additional "path loss" of a terrestrial TV signal travelling 200 km is a mere 6 dB more than the same signal at 100 km. And 300 km is only 9 dB less signal than at 100 km. Basically, people give up too easily when their favourite limited-gain off-the-shelf so-called deep fringe antenna fails to deliver. A Rhombic, Half-Bolic or Logi is the next step beyond the largest commercially available consumer antennas.

FM radio at 150 miles?

"I have a client on a (Texas) ranch 150 miles from the FM radio stations he wishes to hear. On top of a hill behind his house is a 50 foot tower, on top a Winegard (brand) 16' long fringe FM yagi. There is 100 metres of RG-6 buried from the antenna to the receiver. The reception levels vary, rapid fading, sometimes gone totally. Should we look for a better spot for the antenna, build a taller tower?"

David Jeter, Dallas, Texas

First, while the 16 foot long yagi may be as big as Winegard builds, it is not large enough - it lacks sufficient "capture area" to smooth out the peaks and valleys of fading. Step one - a larger antenna with significantly more capture area (a Rhombic if you have the space and most Texas ranches will). Step two - a antenna mounted low noise, moderate gain (not more than 20 dBg) amplifier - but only if there are no local stations that might overload the pre-amp. Step-three, investigate the quality of the FM tuner being used.

There are some really sensitive tuners available - contact Mike Bugaj at ikon@netcom.com for advice on the best tuner currently available.

Sorry - wrong number

"When you telephone L&M (Melbourne) you hear a recorded message saying they have gone into voluntary liquidation. I will have to find another place that can repair power supplies!"

Jack Smith, Victoria

L&M created quite a stir in June because they somehow gave MadMax the South African MOSC card specialist the impression they would represent his service and ECM blockers in Australia. When they realised what they had done, they apparently went into a panic mode and ran - fast - to the nearest exit.

## HARDWARE EQUIPMENT PARTS

## UPDATE

AUGUST 15, 1999

**Fine tuning** linear and circular signals. ADL has come out with their AZOP-120 Scalar Ring equipped with a motor driven bezel. Remotely, you drive the polarisation determining portion of the system by rotating the feed. A 5-turn pot allows precision setting of polarisation as you scan the skies from bird to bird. Various C and Ku or C and C feeds can be accommodated to solve virtually any single dish reception problem. Details from ADL on p. 5 here.

**The photo** may not be too spectacular but the device is attracting interest. In place of your normal smart card, it plugs into the CAM on your IRD. In the middle, a "two card switch" that you operate to select which of the cards you want active, and a "blocker" to ensure the cards are not hit by unfriendly bits.

**How big** is European piracy smart card market? A "tracking agency" there that monitors such transactions reports just over 10,000 "Bulgarian" created DPSC (digital pirate smart cards) were sold during July. Average price? US\$150 each.

**UEC grey market receivers.** Nationwide's pricing for UEC 642 and 660 models (late July) is quoted as \$780 for single quantity, \$720 for 5 - 9. Another UEC 660 version is being imported directly from Multichoice (the pay TV company) in South Africa; Sciteq Pty Ltd, for example, offers it at \$581, others have higher pricing on same unit. Internet postings anonymously suggest the Multichoice IRD is "grey market" (meaning slightly illegal, immoral or fattening - take your pick), also claim it has no warranty, won't work properly in Australia, does not have "proper" Irdeto codes. Sciteq says none of this is true, our SatFACTS Web site posts reports from people who have both and say they are essentially the same - the Multichoice "may be faster" while the Australian version has the proper UHF modulator output channel software. In a letter written late in July, David Dargie of Nationwide wrote, "May I point out there have been some decoders (660s) imported illegally from South Africa. *In all likelihood, they were stolen from Multichoice.*" Indeed. We suspect those purchasing directly from Multichoice would be pleased to show their invoice provided Nationwide shows their invoice from UEC (and we'd publish both here side by side). To which MadMax in Web site posting adds, "I personally don't think the UEC decoders are stolen in South Africa because they are freely available in large quantities and cost a fraction of the price asked in Oz." Like what price? "The going price in bulk buys is around ZAR 1700 which is +/- A\$420; for 100+ the price comes down to around A\$350." There is one more element - Multichoice "subsidises" UEC 660 IRDs through South African distributors which means the street price for a South African consumer can be even lower than the numbers quoted by MadMax. If the Multichoice units coming into Australia are being subsidised for South African use - then all bets are off!

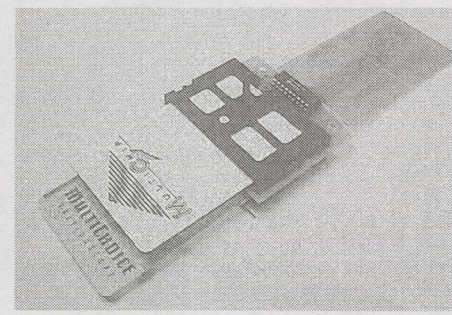
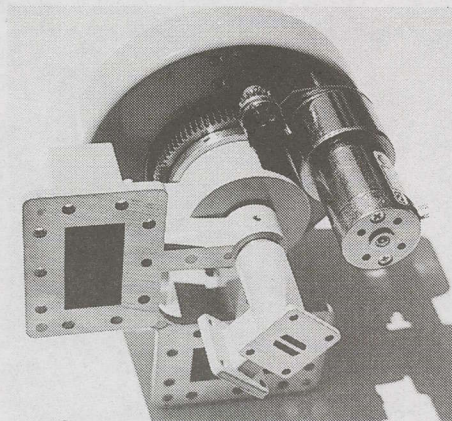



# ADL<sup>®</sup>

BECAUSE PERFORMANCE IS ALWAYS YOUR FIRST PRIORITY

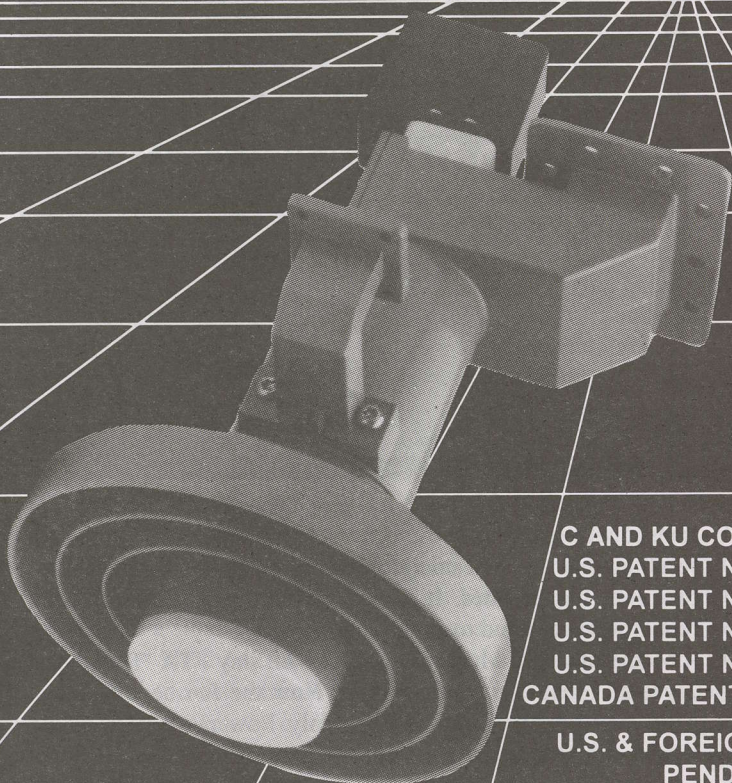

**RP3-CKU/ International  
Adjustable Scalar Ring Feed  
with Extended C Band**

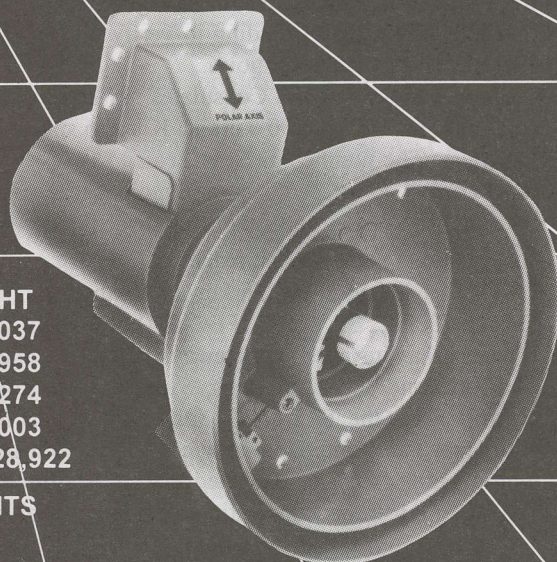

**RPI-CKU Feed**

C AND KU CO-BORSIGHT  
U.S. PATENT NO. 4,903,037  
U.S. PATENT NO. 5,066,958  
U.S. PATENT NO. 5,107,274  
U.S. PATENT NO. 5,255,003  
CANADA PATENT NO. 1,328,922

U.S. & FOREIGN PATENTS  
PENDING

## ADL HYBRID MODING CIRCULAR POLARIZED INTELSAT FEEDS WITH EXCLUSIVE T.I. REJECTION



**RP1-CP400**



**CP-300**



**CPOR-100**

- C BAND LINEAR & CIRCULAR • C/KU LINEAR & CIRCULAR • KU 12 GHz FEEDS
- INTELSAT 4 GHz CIRCULAR • ARABSAT S BAND FEEDS
- OPTIONAL: CO-BORSIGHT S BAND

2216 AGATE COURT, UNIT B, SIMI VALLEY, CALIFORNIA 93065 • (805) 526-5249 • FAX (805) 584-0634

NEW ADL Web site - [www.adlfeed.com](http://www.adlfeed.com)

Nobody saw it coming

## TRT Turn-On Cleans Out Distributor Hardware Inventories

Never - in the brief history of DTH in the Pacific - has a single new free to air (FTA) service created such chaos. TRT, national television for Turkey, is now being transmitted on Optus B3, vertical polarity, on 12.336 GHz. The good news is that this is a very potent signal with a most unusual (first time ever employed) "NANZ" beam that squirts 44 to 47 dBw signals over a very wide area - from Perth to all of New Zealand. We show the official coverage map below. Reports from New Caledonia indicate the signal barely makes it there to a quality 3m dish - tending to verify the "twin illumination footprints" the map here shows.

Sources at the Turkish Consulates in Melbourne and Sydney suggest there are "40,000 Turkish/Kurdish speaking homes" in Australia. The number in New Zealand is less well defined - not believed to exceed 2,500. Suppliers such as Av-Comm, Satech, Sky Vision and others believe they have heard from "every one of these at least twice!"

TRT is linked from Turkey to Perth through Thaicom 3 C-band (3.565, SR 5.698, FEC 3/4). In Perth, a firm called Mediasat has installed a "gateway station" to take TRT off of Thaicom, and link it to their Sydney TOC (toll operations centre). There the TRT (INT - for International) feed is mixed with other video and audio services and re-uplinked to B3 (see tuning parameters, p. 7). Mediasat is a firm that provides "links" to Australian domestic and international clients. They

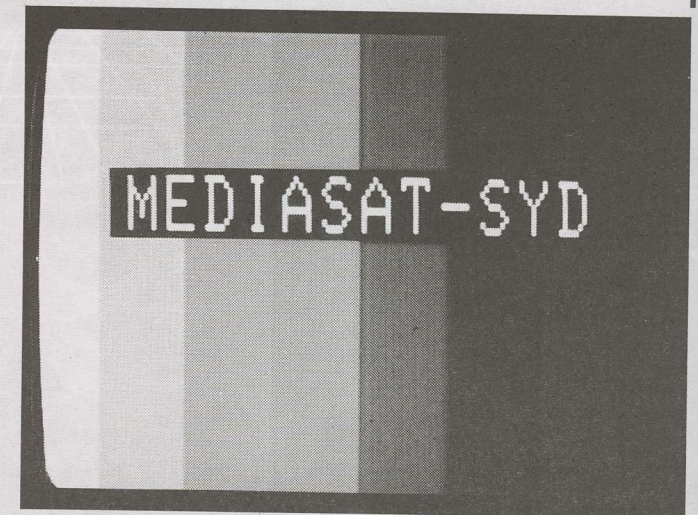

act as a service provider by purchasing large amounts of transponder space at the lowest possible rates and then reselling that space in smaller increments for shorter periods of time - at higher rates. It is the age-old "buy wholesale, sell retail" world applied to satellite.

Mediasat's Paul Mullen says TRT will stay FTA "for at least 2 years" - that is a contract term. Now the fun begins. When TRT first appeared on 12.336, only PowerVu IRDs would load it straight away - because, Mediasat utilises the PowerVu

Possibly you have not seen this Optus footprint previously. "NANZ" beam places 42 dBw over Darwin, 43 dBw over Sydney, 44 dBw over Perth and Brisbane, 45 dBw over Melbourne, parts of Tasmania, 46 dBw over Auckland, Wellington, Christchurch and 47 dBw over a sheep ranch in Otago.

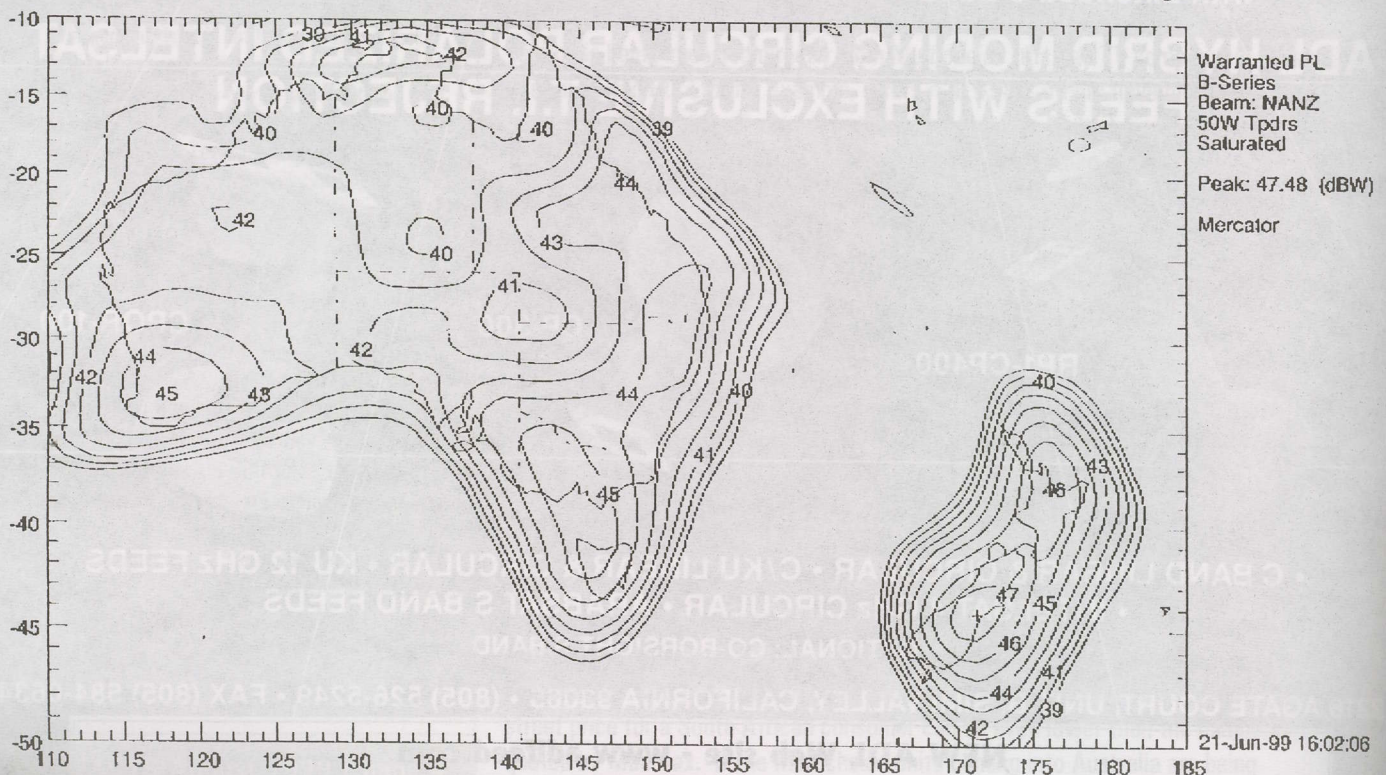

**Footprint (eirp) level (from map) versus dish size for 3 different noise figures (Nf) of LNBF (top line)**

	1.2 dB Nf	1.0 dB Nf	0.6 dB Nf
47 dBw	90 cm	75 cm	60 cm
46 dBw	1m	82 cm	68 cm
45 dBw	1.2m	90 cm	75 cm
44 dBw	1.3m	1m	82 cm
43 dBw	1.5m	1.2m	90cm
42 dBw	1.6m	1.3m	1m
41 dBw	1.8m	1.5m	1.2m

Note: Antenna size and LNBF Nf given for 3 dB above threshold margin - typical IRD.



The objective - TRT-International

MPEG-2 format. Mullen describes PowerVu as "the only truly DVB-Compliant MPEG format" which sounds very much like something SA would say. And nobody - including Intelsat, agrees with that statement. So there was TRT on 12.336 and surprise - many of those IRDs that normally can handle PowerVu were not getting in. Sky Vision Australia quickly found that if you used PID/PCD numbers, their IRDs would play TRT (VPID 1360, APID 1320, PCR 1360). However, by August 2, Mediasat had modified the TRT data stream such that those IRDs that normally play PowerVu without PID/PCR entry were now working normally. Mullen told SatFACTS, "We did a small change in the data stream to correct this." Of interest - UEC 642/660 IRDs not only would not play TRT, but until the data stream modification was done, these IRDs locked up so totally on TRT that the only way you could get the UEC to work again on *anything* was pull the mains plug and reboot it!

TRT has done an excellent job of notifying the Turkish/Kurdish community of its availability on satellite. And this has attracted some new "competition" for the established dealers and distributors. The timing could not have been worse.

Even with the data stream "fix" the user requires a PowerVu compatible IRD. This says older models (example: SK888) are of no use for this service. Leon Senior at Satech: "In the first week, I believe we could have sold 2,000 IRDs. Unfortunately, we were cleaned out of inventory in the first

couple of days and in our case, our (normal) Korean factory is shutdown and not shipping for virtually all of August - because of summer (there) vacation time. We faced a tremendous demand and no equipment!" Garry Cratt at Av-Comm: "We somehow got onto the 'preferred supplier list' and our phone has rung off the hook. I have several observations. First, most of the callers want the lowest possible price and refuse to accept that cheap hardware equals poor reception and reliability. I have never encountered such a bargain hungry group before in all my life! Second, I am not going to compromise our standard guarantee of performance or backup warranty by being forced to come down to \$850 installed."

Price is a concern here. Enter into the equation a Turkish businessman who is making a number of interesting "promises" to his fellow country men. First, he is importing a Korean built Humax IRD. There is concern - which may be settled before you read these words - *that Humax is PowerVu compatible*. Humax is available in several models, *all* designed for Europe. The F1-CI version is the one coming to TRT subscribers and it has a "common interface" slot for a smart card. The importer also claims, "It will do Irdeto." There is no confirmation of this, either. The Humax F1-CI is advertised in European magazines for the equivalent of Australia \$600. Then there is the second half of the promise - perhaps a "carrot" to entice customers to his package of equipment. He says he has talked with Optus about adding "one or two Turkish pay-TV (read movie) channels" to the Aurora platform. "If you purchase our (Humax) IRD package, we will guarantee you access to these services when they become available." Which makes the claim that the F1-CI will do PowerVu and Irdeto most important.

With the assistance of a New South Wales dealer of some reputation who has been enlisted to round up installers, the Turkish businessman has gone back into his ethnic community to offer a \$850 package - IRD, dish, antenna - all installed. The installers are to receive around \$100 for their labour - and be provided everything but the cable, clips and connectors. As SatFACTS was heading to press, he was promising "hundreds of install orders as soon as the equipment (Humax IRDs) arrive." (see p. 29, here for update)

Obviously there is going to be quite a but of fall out from this one. As Garry Cratt pungently observes, "one day they are selling washing machines, and the next day they are satellite

**PowerVu Tuning Parameters for Mediasat Bouquet**

Channel	Service	VPID	APID	PCR
1	Maharishi	1,550	1,520	1,550
2	(audio)		1122/23	
3	Mediasat 1	1,260	1,220	1,260
4	Mediasat 2	1,160	1,120	1,160
5	TRT	1,360	1,320	1,360
6	(audio)		1322/23	
7	Medisat 3	1,460	1420/21	1,460
8	#1012			3,191
9		4,000		4,000

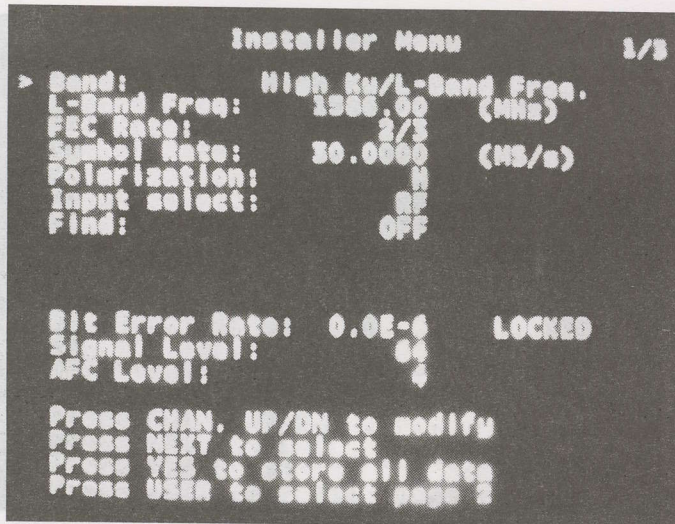

No bit errors - or as close to it as you are likely to see. BER 0.0E-6 of TRT signal in NZ on SA D9223.



TRT newscasts, much like Sky News London, brings viewers the daily Ankara front page.

TV experts. " And lest you think that sounds like sour grapes, consider how many mistakes you made yourself in breaking into this industry and how glad you were afterwards those mistakes were small enough that they didn't bury you in the process.

Even if the \$850 price does not stick (the antennas, LNBFs reportedly were first sourced from Hills, then cancelled), the memory of the low-ball pricing will stay with us as a legacy for years to come. And if it does stick - well, perhaps you have noticed that inside of the Mediasat bouquet have been some tests for some Thailand feeds. What is that about? Paul Mullen is not saying but there seems to be an excellent chance that other countries will follow the Turkish lead and link their own national feeds to Australia for redistribution on an Optus satellite. Dare we suggest that one year down the road, there will be several ethnic FTA services available off of Optus? Or perhaps PAS-8?

Which leads us back to the hardware. For virtually all existing Optus consumer installations, a single dish equipped with a single LNBF has been the standard format. Meanwhile, in Europe and North America, the more common antenna configuration is a single reflector equipped with two (or even three) LNBFs - each for a separate satellite. We have previously seen how PanAmSat has provided users of the PAS 2 + PAS 8 satellites with modified C-band feed systems capable of simultaneous reception from both satellites. This format, on a much cheaper scale, is the way most installations are done elsewhere. You start with a single (offset) reflector,

place a horizontal arm across the LNBF support, and hang two or more LNBFs at appropriate spots on the arm to coincide with the focal point for different satellites. We diagram that below.

In New Zealand, for example, twin LNBFs for B1 vertical (Sky New Zealand) and B3 vertical (TRT and others in the Mediasat bouquet). In Australia, as the uses for B1 grow during the next 6 months (Internet distribution is coming here very shortly; Telstra's package before the end of this month), twin LNBFs on existing or slightly larger than existing dishes will allow simultaneous use of B1 at 160E and B3 at 156E with a single reflector. A similar package could be offered to add PAS-8 Ku to B1 (and B3) antenna systems. TARBS, as another example, does not really require a separate dish from 166E - only a new LNBF appropriately fitted to existing (or slightly larger) B3/B1 antennas.

Of course when a single reflector is chosen for two or more satellites, it should be a size or two larger (such as 75 cm where 60 cm is now being used) to compensate for the 1 to 3 dB loss that always happens when a reflector is "split" between two satellites. And that is one of the "dangers" associated with people who become over night satellite experts from yesterday's washing machine sales floor. Without some reasonable knowledge base in what satellite TV installation is all about, and how it is growing by the month, you make mistakes in selecting antenna size and type, LNBF format and mounting configurations which can come back to haunt you. The players here will only learn this the hard way.

What size dish in New Zealand to co-mount separate LNBFs for B1 vertical (Sky NZ, ABC NT Australia) and B3 vertical (TRT bouquet)? See drawing to right - table below for dish size versus LNBF noise temperature with a 3 dB headroom margin for rain fading.

	1.2 dB Nf	1.0 dB Nf	0.6 dB Nf
47 dBw	1.2m	90 cm	75 cm
46 dBw	1.2m	1m	82 cm

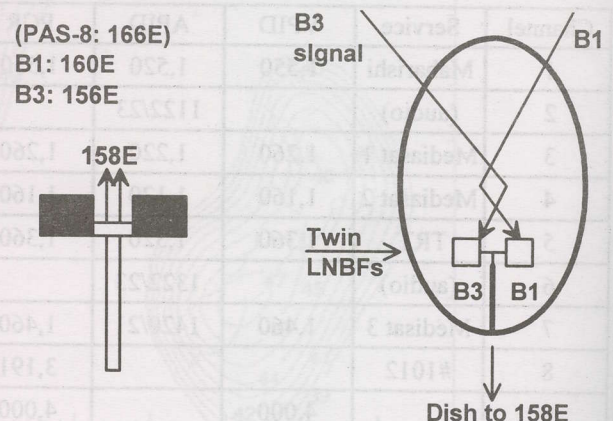

# The Most Advanced Free To Air Digital Satellite Receiver D7-MediaStar

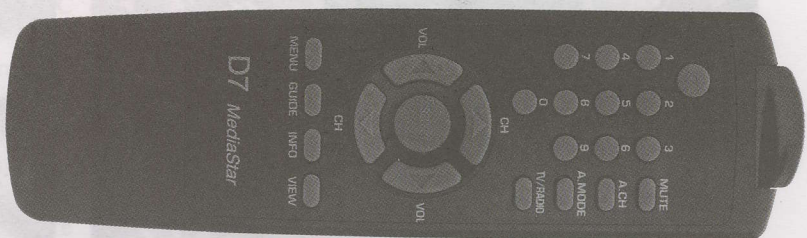
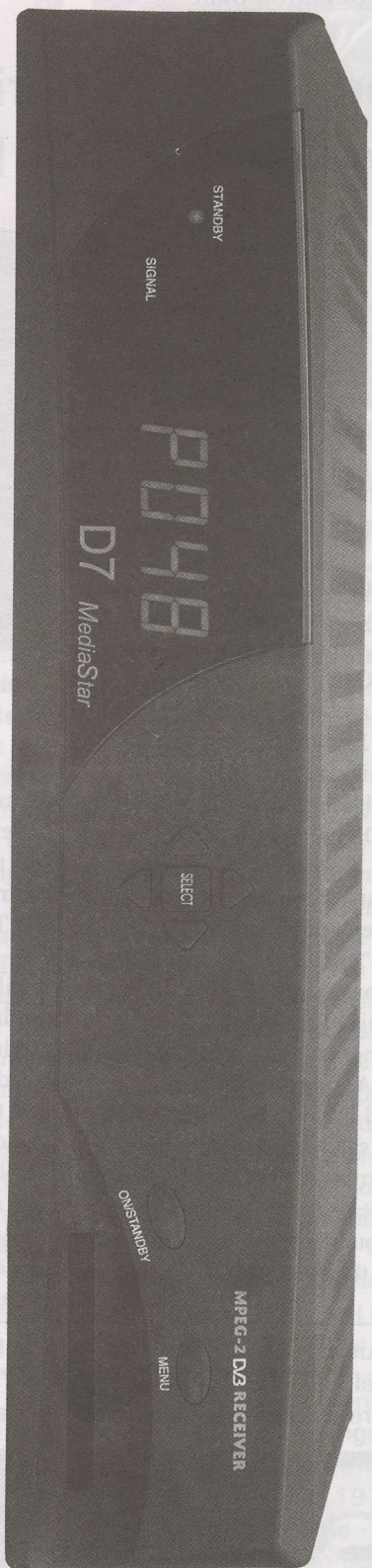

- MCPC/SCPC 2-36 Msym
- Direct channel selection from channel list
- Channel Edit menu Delete, Skip, ON.
- Fast response when changing channels
- No channel over-write
- 200 Video 100 Audio channels
- Automatic search and download
- 22 KHz switch
- PID Menu
- NTSC/PAL Auto switching NO NTSC Glitch
- NTSC converted to PAL-60Hz Free Option
- Audio L, R, Stereo selectable via remote control
- RF Modulator PAL-G, VCR/TV Scarts, RCA Audio/Video, SVHS outputs.
- 90-265VAC-50-60Hz power supply
- Low threshold performance



MediaStar Communications International  
24 Bosci Road  
Ingleburn NSW 2565 Australia

E-mail [opac@bigpond.com](mailto:opac@bigpond.com)  
Tel + +61 2 9618 5777  
Fax + +61 2 9618 5077

Praise the Lord and pass the donation plate

## Full-time, Live, American TV Religion is Available in the Pacific & Asia

The oldest, most established and some would say the most respected "religious telecaster" in North America - and the world - is Trinity Broadcasting Network (TBN). Trinity is now - since July 31 - available in the Pacific and is scheduled to be available in Asia as well from 1 September. In fact, the first report of Trinity being available was through JcSat3 at 128E where Trinity first appeared on July 28 (3.990/1160Vt, SR 5.026, FEC 3/4). Within days Trinity's live from the USA feed also appeared on Intelsat at 180E buried inside of the partially FTA / partially CA PowerVu bouquet on 3765/1385RHC (SR 29.900, FEC 7/8 - unfortunately). This 180E MCPC bouquet has been home to CNN feeds, networking links for the daily Jerry Springer, Oprah Winfrey and other shows for approximately one year. Officially, the bouquet originates in Los Angeles (Pacific Television Center - often seen on test cards here) with "10 Australia" as a client. There is something slightly amusing about noting that Jerry Springer and TBN are only a dial position separated on this bouquet. (1)

The "Ten Australia" bouquet, although listed here from the beginning of its operation in our Digital Watch tables, has not previously attracted major interest. TBN is likely to change the situation - perhaps to the extent that other users of this bouquet will be more conscious of what they are transmitting. There is already evidence that "adjustments" may be underway. (2)

TBN began as a single low power UHF station serving a small portion of Southern California. That was 1973. In 1978, the station went nation-wide using an RCA operated cable television programming satellite. A surprise at the time - the station was only slightly interested initially in getting carriage by cable TV. Rather, they saw the satellite (correctly) as a way to feed their local Southern California originated programming to what would grow into a 650+ station "network" spread literally all over the world. The founders of the small station, Paul and Jan Crouch, followed in the footsteps of Ted Turner

TBN founder (Dr) Paul Crouch (left) has led TBN from a local UHF station serving a portion of Southern California to an international network of more than 600 TV stations from Russia and South Africa to the USA. Station promos feature instantly recognised personalities - such as former President Ronald Reagan.

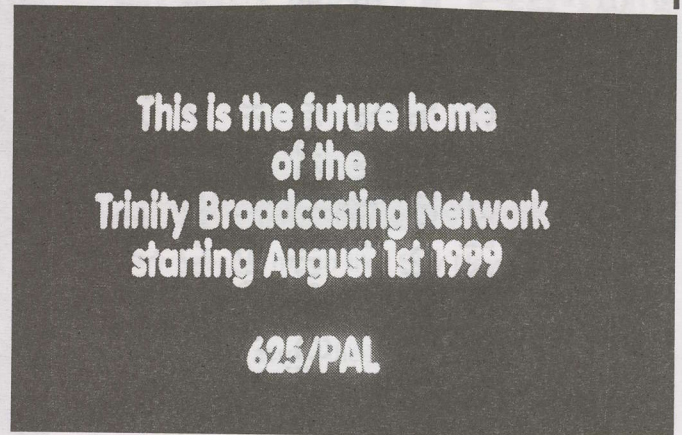

This was the announcement up late in July advising the new transmission location for TBN (which began July 31).

in making the satellite their link to hundreds of affiliated outlets. What Turner did for commercial television, Trinity did for religion. And they soon had imitators, including the controversial PTL service that was begun by TBN alumni Jim and Tammy Bakker.

Trinity is an eclectic blend of revival religion and family-values-television. It is 24 hours a day from studios and production centres scattered across America, mixing live productions (largely religious and family values talk shows laced with revivalist singing and guest appearances) with 30 and 60 minute slots purchased by a wide range of television preachers. The time sold to preachers is a source of revenue to TBN (the revivalists buy the time to be on the TBN system) and each in turn raises his or her revenue from the viewers. They offer prayer books, jewellery, special editions of the Bible, and offers to "pray for you - the viewer" in return for a (financial) donation. Some find this type of television



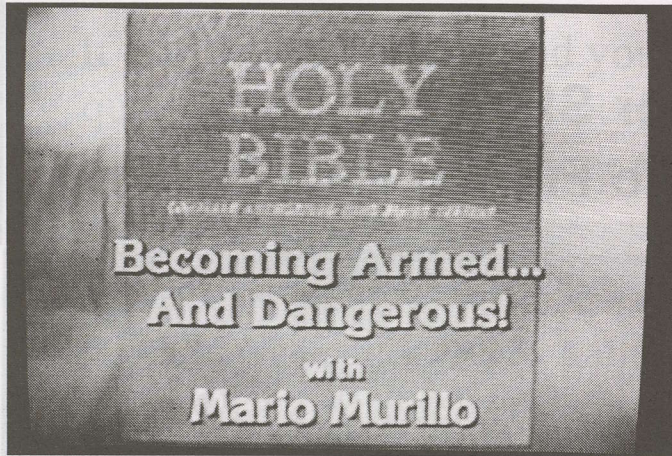

Although Trinity relies heavily on a cross section of preachers/ministers/pastors each of whom bring their own "take" on religion to the schedule, it basically follows three covenants: "Faith in God, Love of family, (American) Patriotic Pride." And, it offers unique "gifts" to the faithful such as the TBN anniversary medallion (right) which it promotes as a "Gift of Love for a loved one."

offensive and that includes most traditional religious professionals.

One of the early battles TBN fought was a fear that by importing "professional," evangelical preachers into a community via television, the local churches would lose attendance (and financial support). And in fact there has been a certain loss wherever TBN (and others who have followed their example) have gone. Balanced against this loss is the spiritual value viewers place in having TBN available in those many regions of the world where no organised religious facility exists anyhow.

It should go without saying that TBN is a free to air service, and will actually help persuade cable (and larger SMATV as well as broadcast) stations to carry them by arranging for equipment - such as IRDs - for this purpose. Their new I180 feed replaces S-VHS tapes that have been bicycling around between New Zealand, Australia, Samoa, Fiji and other island destinations for more than a decade. Director of Engineering Ben Miller advises, "Our tests on JcSat3 are part of our plan to serve all of Asia as well. We have many interested Indian cable systems waiting for service, but we will have to find the correct satellite and the best footprint to make this happen." They have a 1 September target date for Asia - JcSat3 does reach India in the 35-36 dBw range and a tiny amount of signal spills into New Zealand and Australia as well (in the 28 dBw and down region - you'll need a quality 3.7m dish to see this feed).

The I180E feed - primarily because of the unfortunate FEC 7/8 choice - is going to make watching this service difficult for any but professional installations - even if they leave the eirp (power) "up." Engineer Miller has no illusions about this feed, "It was never intended to reach individual homes." And in fact with the 7/8 FEC, the difference in reliability into New Zealand and Australia at this point between JcSat3 and I180 is very small indeed (the JcSat3 test signal to date has been FEC 3/4, much more friendly to smaller dishes).

If you sell and install satellite dish systems - as most readers of SatFACTS do for a living - who are the potential customers for Trinity? Chances are the reputation of the service will get to any potential clients before you do - TBN is synonymous throughout the "family value" world for what they have now spent more than three decades polishing into a fine art. There is far more here than simply "religion" although the religious

message (in its many forms - there are Catholic, Jewish and nondenominational presenters on TBN in addition to the obvious born-again Baptist flavour) is very strong. If the full 24 hour, 7-day schedule is too much for any but the cable operator searching for a new category of programming to help balance out his existing programming, segments of the broadcast week may not be. Perhaps the way to approach locating clients for a TBN installation is to acquaint yourself with the content ([www.tbn.org](http://www.tbn.org)) and then select those scheduled shows which might have some appeal to specific target groups. The programme schedule as a whole is or can be overwhelming and because there are multiple "faiths" on TBN, there are conflicts between programmes which may do more to anger potential dish system owners than convince them they need this service. Their standard broadcast "day" is another challenge - because of time zones. Like any intelligent network with a broad range of programming to choose from, TBN slots programming based upon time of day at the intended receiving site. This creates special problems for the Pacific feed on I180 because when it is the correct time for the TBN children's material in Perth, prime time (evening viewing) is in force in Tonga. TBN is delaying the Pacific feed by 8 hours from California release - perhaps not the correct delay but a recognition that we are not a part of the USA and require some consideration for where we are!

1/ Slightly more amusing was a "shared transponder" arrangement between the Playboy Channel and another North American religious broadcaster in the 1978-1980 era. Playboy started at 8PM local time - religion quit only seconds before. More often than not, the church folks were slow to switch off the religious feed at 8PM - it was all on an "honour" system in those days and completely FTA!

2/ Tony Drexel of Free to Air Satellite, South Australia, reported to SatFACTS Daily he found the bouquet went down 3 dB in level two days after TBN started there. His call to Intelsat in Washington, DC restored the level within hours proving the power of the telephone.

## Pacific Sat or Skytel? Another Hat in the Pacific French Pay-TV Ring

What is it about people who live on islands in the Pacific? They want to play "the game" but somehow never bother to read the "rule book?" Yes, the promised multi-channel French language pay-TV service is back. Well, sort of back. Then again - it may not be the *same one* we were previously promised!

The detail. Gorizont at 142.5E was so badly inclined that for all useful purposes it had no useful purpose. So the Russians, combining financial forces with American firm Lockheed, quietly decided to shift the ex-on-loan AsiaSat G from 122E to 142.5E. This in spite of previously announced Russian intentions to stick ex-G around 75E. So now 142.5E has a *less* inclined Gorizont (which the Russians and Lockheed have renamed LMI-AP2 - the 2 being in sequence from AP1 which as we all should know is hanging out at 130E). On July 29 (UTC) up comes a powerful signal on 3675 - transponder 6 in the Russian way of counting. This is the 75 watt capable global beam which has been a trademark of the last series of Russian birds. The signal is analogue, PAL, consisting of a continuous video "loop" that repeats itself every 12 minutes or so. Sitting through the full loop, you are introduced to a new "8 channel pay-TV package from Pacific Sat(ellite)." The package, unlike the looping promotion, is to be digital, and you are led to believe it will be located on the same transponder you are watching - TR6 of LMI-AP2.

Pacific Satellite? They turn out to be a firm in Noumea (New Caledonia). A search of the records reveals there are some court awarded judgements against the firm amounting to many thousands of (US value) dollars. What do they do for a living? Apparently they have installed satellite TV systems, do general television work.

And the 8 programme channels appear to be an almost carbon copy of the Skytel promised package we wrote about in



May (see p. 32 that month for a refresher). Skytel had promised 8 digital channels using a Russian satellite (130E was so-mentioned at the time). Skytel claims Pacific Satellite is not them, they "know nothing" about it. Strangely, both are headquartered in Noumea, both have the same basic programme channels, both are identifying inclined orbit Russian satellites as their home base. Oh yes, Skytel in May identified Pacific Satellite as "*our installation firm.*"

Why would either of the firms be on 142.5E for a brief three days? Possibly to "save face" over an embarrassing situation; possibly because they got "free uplink time" - so why not!

The "real" French Islands pay-TV service - we are betting - will be the Canal + package still scheduled for Intelsat 180E on a steerable Ku beam to 80 cm dishes - they hope by Christmas (see p. 2, SatFACTS July). And these other guys? Well, it makes for amusing reading on our Web site.

French Canal + officials "went into a frenzy" when the continuous loop promotion for the perhaps hastily renamed "Pacific Satellite" went on the air from 142.5E.

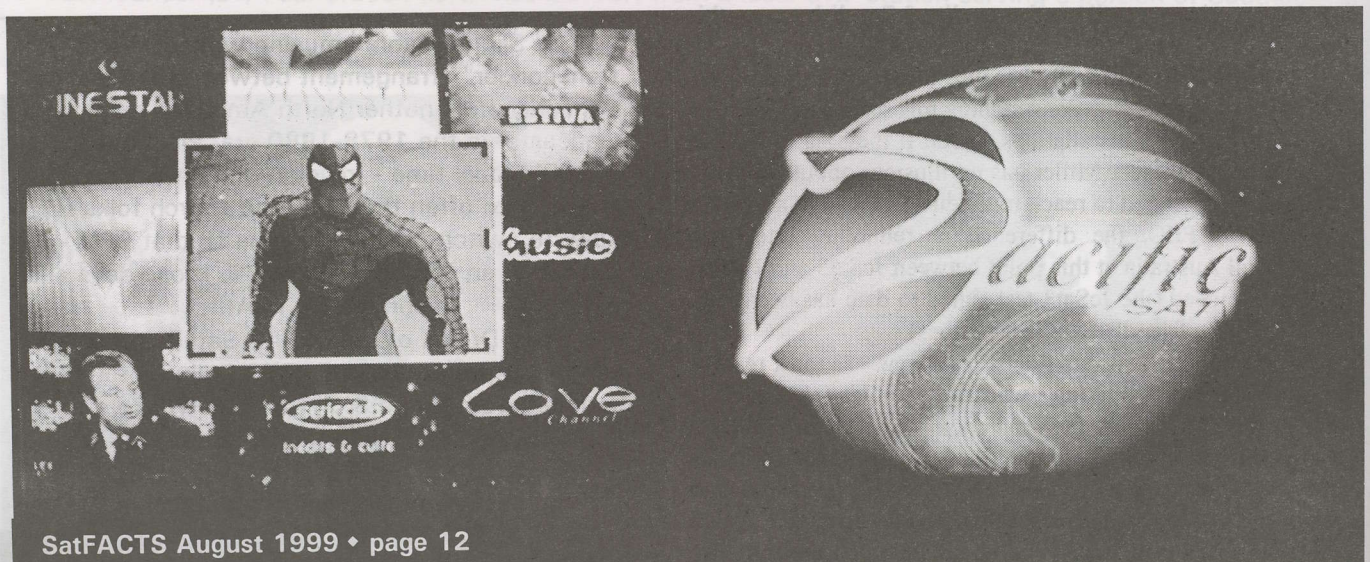



It is 6PM on a Friday and you suddenly need 20 qualified installers for a special project by 8AM Monday. *There goes the weekend.*



And perhaps - one heck of a good contract.

Two totally unexpected pallets of TRT capable receivers just arrived at the airport. How do you get the best price for them in the shortest period of time?



Perhaps you could look up "*Turkish Restaurants*" in the yellow pages?

You have been given 24 hours to locate a D9234 or equivalent *authorised* for WIN and GWN. And you don't know a single person in Western Australia!

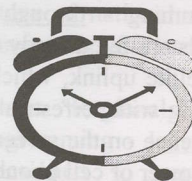

And Scientific Atlanta says, "You are on WHAT island in the Pacific???"

### The answer:

- ✓ Instant access to thousands
- ✓ Instant response
- ✓ Confidential dealings

### The medium:

<http://www.satfacts.kwikkopy.co.nz>

## ***We call it SatFACTS Daily.***

*During July 6,236 people accessed it because they needed to know the latest in our industry.*

If you need current information - fast - daily, go to  
<http://www.satfacts.kwikkopy.co.nz>

If you need installers, special equipment or information **NOW** - not next week or next month - you can **ADVERTISE** on the **SatFACTS Daily Web Site!**

Buy - sell - swap - locate personnel. All you need is our email address (Skyking@clear.net.nz) or fax number (+ +64-9-406-1083) and either a VISA or Mastercard credit card. Tell us precisely what you wish said, how long you want it to appear on <http://www.satfacts.kwikkopy.co.nz>. We will get right back to you with a quotation of costs. When we have your approval, it will be on our site within 3 hours!

## **SatFACTS DAILY - On the Web**

*"We talk to thousands every week"*

Is this a sneaky way to "kill" terrestrial TV?

## Australia's Broadcasting Services Amendment Bill has very curious language and intentions

First there was terrestrial TV (transmitted through the air on VHF and UHF by government licensed broadcasters). Then there was satellite TV (transmitted through the air using microwave frequencies from satellites with some programmers licensed [Austar for example] and some not licensed [KIBC, for example]). The terrestrial broadcasters have "squatter rights"; they were there first, have made piles of money with their licenses, and terribly resent any intrusion into what they now call "their territory."

In the United States and the UK, satellite TV viewers can receive satellite programming as well as terrestrial TV programming - through their satellite dish. UK terrestrial channels are fed directly from the studios of the broadcaster to the satellite uplink, which eliminates any need for consumers grappling with terrestrial rooftop aerials, ghostly images, and interference on the screen when their neighbour cranks up his lawn mower or cell phone.

New Zealand's Sky service and the New Zealand terrestrial networks (TV1, TV2, TV3 and TV4) tried to work out such an arrangement two years ago; they could not agree on the terms. The New Zealand situation is unique, perhaps in the world, because the Government regulators have essentially eliminated all rules and regulations leaving the future development of television (and radio) broadcasting to "the free market." (1) In the United States, while many cumbersome regulations have been eliminated, the watchdog agency (Federal Communications Commission) still intervenes when it believes "the best interest of the public is involved." Now Australia comes to decision making time. How will terrestrial (the original "free to air") television and satellite TV coexist in the future? Should they follow the New Zealand format, eliminate all rules and then stand back to see which side has the most clout and cunning? Should they take the UK road and mandate that terrestrial TV services shall be carried by satellite TV as a condition to satellite TV being allowed to operate? Or the American approach where the Government steps in to recommend direction for development, establishes a few ground rules and then steps back to allow market forces to settle the fine points?

### Broadcasting Services Amendment Bill - 1999

Here is the problem. Television broadcasting and computer based communications are merging; "live" television is available on Internet, within the foreseeable future the technology to deliver what we now call television broadcasting through a telephone company owned and operated wire/cable/fibre optic network will challenge over the air broadcasting. On a parallel development path, satellite

1/ New Zealand law allows a firm to gain a dominant position in the marketplace as long as (they) do not use that position for the purpose of preventing, deterring or eliminating competition (Commerce Act of 1986).

delivery of television as we now know it, and Internet as we now know that format, are merging into a single "seamless data stream." Already Government agencies are confused who should be regulated and how the regulation should proceed. If Telstra offers video over their telephone lines in Australia, have they crossed the line into "television broadcasting?" If C&W Optus offers telephone and Internet connections through their cable television network, what are they - a telephone company or a television broadcaster? If Austar adds Internet services to their satellite TV package, are they a telco?

It is all a matter of timing. Regulations created to administer telephone circuits are and have for all time - until now - been quite separate from regulations created to administer television broadcasting. And within television broadcasting, regulations built around the concept of terrestrial free to air services fall apart when applied to limited access pay-TV services.

Further complicating the job of regulators is the transition to digital television. Analogue TV licenses are based upon one licence for one transmitter which equates to one TV programming channel. When the telecaster converts to digital, one TV "channel" will support four or five (or more) separate *programme* channels. Moreover, within a TV channel spectrum, the broadcaster could elect to transmit one (digital) TV programme channel and with spectrum left over from that also transmit Internet delivery, radio paging services, even telephony. Obviously the rules created for analogue no longer fit. And the demarcation line between television broadcasting and data delivery / telephony blurs again.

The BSAB is an attempt - some are saying a convoluted effort - to establish new ground rules for at least portions of this quandary. The bill is being introduced by the sitting Government, and is tied to "political objectives" of the present Government.

### The role of existing free-to-air broadcasters

As virtually 100% of all existing television sets in use rely upon terrestrial FTA television, and there is a 43 year record of terrestrial broadcasting in Australia, Government does not want to see any new technology applied in a manner which jeopardises the continuation of FTA terrestrial TV service. The broadcasters argue they were there first, provide a national service, deserve to have senior status with protection from the new guys. The new guys argue for a chance to become old guys.

Point. Numbers released early in August from something called the ACNielsen survey of pay television audience in Australia. For the first time ever, an accurate statistical analysis of who pay-TV viewers are and how having pay has changed their viewing habits. Two facts jump out - those who have pay-TV now spend 46% of their TV viewing time watching pay-TV. That's 46% *less time* they spend with free to air terrestrial television. And while only 7.3% of all Australian homes have pay-TV, the percentage of homes with pay rises sharply for the higher income, better educated families. Australia, like elsewhere, has seen the quick take up of pay by homes with more money to spend. It happens that these are the

---

**Title:** Broadcasting Services Amendment Bill - 1999

**Proposes:** To amend the Broadcasting Services Act 1992

**Introduced:** Second reading before Parliament occurred June 28 (1999)

**Debate scheduled:** Anytime from August 9 onward during "Spring Session" of Parliament

---

people many advertisers most wish to "reach." For homes with \$140,000 annual income, 43% already have pay-TV; for homes with \$100,000 and up, 33%.

Advertising for pay-TV is new, amounted to only \$20 million in the first year. That's in a TV advertising universe of \$2 billion - 1% of total. In USA, where pay-TV reaches 75% of all homes, pay advertising amounts to 20% of all TV advertising. Terrestrial broadcasters (7, 9, 10 and their regional affiliates) know what happens next - pay-TV grows, pay-TV advertising grows, and revenue for free to air advertisers *drops* as FTA broadcaster profits go down.

There are other challenges to FTA terrestrials. Pay-TV generally delivers blemish free picture and sound. FTA terrestrial delivers but the final link, the TV receiving aerial at the home, determines how good the image is. And the terrestrial broadcasters have absolutely nothing to say about whether a home installs an adequate aerial or not. If a home with tarnished FTA terrestrial signs up for pay, and finds the quality of picture so dramatically better on pay (whether satellite or cable), even less time is spent with the terrestrials. What the terrestrials would like - as they have opted for in the USA and UK - is to stay as FTA services but somehow manage to have their service delivered as a part of the pay-TV package. In this way, they get at least the same *quality* image and sound into the home as the pay-TV folks. And this means viewers choose their programming based upon programming content, not whether the image is crisp and clear.

So how does the terrestrial broadcaster muscle into the pay-TV delivery stream without letting on how worried he is about the future? There is a very short window of opportunity here - as they have learned in the UK and USA. For a brief period while pay-TV is serving 25 percent or less of the homes, pay-TV will benefit from having FTA terrestrial services in their channel packages. Once pay reaches a critical mass of viewers, it doesn't need FTA to boost their growth. And looking down the road to sale of advertising on pay-TV, at some point pay would prefer FTA terrestrials *off* their data stream because to keep them there gives the terrestrials more clout when selling advertising time to sponsors.

#### The proposals

In a "white paper" entitled **Television Fund - Issues Paper**, produced by the Department of Communications, Information Technology and the Arts, the Government proposes (parallel to the Broadcasting Services Amendment Bill) to do the following:

1) Identify areas (called 'Black Spots' in the paper) where terrestrial television does not reach

2) Study how the Black Spots can be turned into regular coverage areas, using a variety of technologies, and at what costs to Government (and the public).

Here are the possibilities debated in the paper.

1) Build more low power relay / translator stations

2) Create a scheme that either mandates (forces) or encourages (optional) pay-TV broadcasters to add to their

service bouquets the existing free to air channels making up the 7, 9, 10, ABC, SBS and where applicable 'community TV' services

3) Create a system that encourages existing free to air broadcasters to place their own existing terrestrial signals on satellite such that viewers in their designated licence areas could access the signals via satellite where terrestrial aerial reception does not work.

The UK model simply places all five national networks on satellite and viewers receive the exact same signal via satellite (although typically at better quality) as they could or would with an aerial in or on their home. Australia differs from the UK in that non-metropolitan markets (regions) are served by "Regional Broadcasters" who exist independent from the three national networks (7, 9 and 10). The USA model is similar to Australia but on a larger scale - there are seven national networks and in 230 "markets" or regions each of the national networks has a local affiliate station. The affiliates are like the Australian Regional Broadcasters - typically owned separate from the networks, carrying a mixture of national network originated programmes plus programming the affiliate creates or supplies on their own.

The USA "affiliate" and the Australian "Regionals" share a major area of locally important programming - local news, locally produced programming designed to serve the geographic region where they operate. In the UK model, there is virtually no local or regional service except that provided by the national network. The Australian and USA systems encourage local service and this local service is the strength of the system. It also creates major problems for linking the services to satellite.

In the UK it takes five programme channels out of a satellite bouquet of 160 programme channels to bring national network television to each home in the country. In the USA, it would require 230 markets times 7 network affiliates in each or 1,610 satellite programme channels to put all of the network affiliated stations on satellite - in a universe of approximately 500 total satellite channels. This is clearly impossible with existing technology and costs. Australia would require sufficient satellite programme channels to allow each regional broadcaster to place his regional and sub-regional mix of network (7, 9 and 10) plus local programming on satellite; the exact number of programme channels is not known but more than the 5 of the UK and less than the 1,610 of the USA. This model looks good on paper, but is probably not practical simply because there is not sufficient satellite transponder space available to accommodate all of these versions of regional service plus a growing pay-TV channel selection. Nor is there presently the funding available to allow regional operators to pay the cost of satellite transponder space if it was available.

In the Television Fund - Issues Paper, the Ministry argues in favour of establishing a "panel" to make final decisions as to which "black spots" will gain additional terrestrial service, and who will pay for these extensions. When "black spots" are individual households, or a cluster of households too small to justify their own terrestrial relay, the paper suggests "(Government could) *provide assistance to individual households to obtain DTH reception.*" This is one proposal of many, included for debate not necessarily indicating a direction the Ministry favours in new legislation. The key to

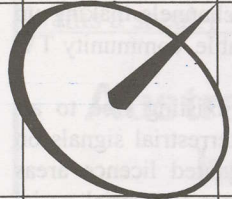

# SATECH

Satellite Communication Technology Pty. Ltd.



## Phoenix 333

### "THE BENCHMARK IN A NEW GENERATION"



### Phoenix 333

As quoted in November Issue of SatFACTS

*"If we were forced to make a decision between owning any digital and any analogue receiver we would decide on owning the Phoenix 333"*

3 in 1 Digital-Analogue-Positioner

High Sensitivity on Digital

Low Threshold on Analogue

Heavy Duty Power Supply for Positioner



## Phoenix 111

### "REVOLUTIONARY IN COST AND PERFORMANCE"



### Phoenix 111



**Power Supply and Software  
Specially Designed for  
Australian Conditions**

Digital

High Sensitivity Loop through Tuner

Built in Digital NTSC to PAL Converter

Heavy Duty Power Supply



Sole distributor for Phoenix Worldwide



# SATECH

Satellite Communication Technology Pty. Ltd.

Head Office: 6/477 Warrigal Road Moorabbin East Victoria Australia 3189 Ph: 61 3 9553 3399 Fax: 61 3 9553 3393

**One Stop Shop**

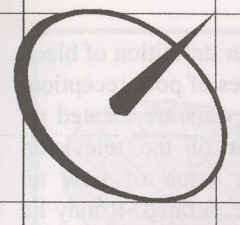

**SATECH**  
Satellite Communication Technology Pty. Ltd.

**ATTENTION!**

This is not a clearance sale  
of our old stocks like other companys'  
**BUT**  
a genuine sale for 1 month only!

**SATECH**  
**Distributors for the**  
**Full Range of CALAMP**

**CHECK THIS OUT!**

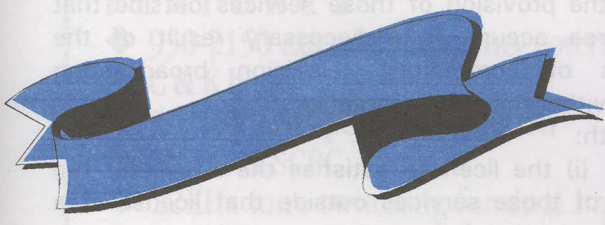

- CALAMP C BAND 25K VOLTAGE SWITCHING LNBF
- CALAMP KU BAND 1dB PRIME FOCUS VOLTAGE SWITCHING LNBF
- CALAMP KU BAND 1dB OFF-SET VOLTAGE SWITCHING LNBF
- CALAMP C BAND DIGI-READY PHASE LOCKED LOOP 25K LNB
- CALAMP C BAND MINI-MAG 17K LNB
- CALAMP C BAND MINI-MAG DIGI EXTENDED 20K LNB
- CALAMP KU BAND 0.8 dB LNB
- CALAMP KU BAND 1dB HIGH STABILITY LNB
- CALAMP C BAND EXTENDED PROFESSIONAL II LOW PHASE 20K
- CALAMP MMDS INTEGRATED ANTENNA

**PACKAGE DEAL**

2.3M Polar mount dish  
Phoenix 111 digital receiver  
17k Voltage switching LNBF

**\$799.00**  
ex tax  
plus freight

**SATECH your No.1 Paraclipse distributor  
for the complete Paraclipse range**

- Paraclipse Dishes
- Exceptional strength and wind resistance
  - Accurate reception

**WHEN  
QUALITY  
COUNTS**

**Paraclipse**  
HIGH-PERFORMANCE ANTENNAS



**All products available through the following SATECH Distributors:-**

- Southern Satellite - South Australia -Tel: 08 8377 0955
- Norsat - Western Australia -Tel: 08 9451 8300
- Network Satellite Services - NSW -Tel: 02 9687 9903
- Satech - Head Office Melbourne Victoria -Tel: 613 9553 3399

"black spot" correction, the paper urges, is to first determine the number of people affected by reception problems and then (2) quantify the size of the black spot, (3) define the number of channels with inadequate reception within the black spot, (4) suggest how many additional channels should be available, (5) determine that as all terrestrial television transitions from analogue to digital format, whether the present analogue black spot will be covered by a new digital transmitter, and, (6) the cost of the preferred solution.

At this stage, nobody is even estimating how many black spots might be catalogued. If one home standing alone in a poor reception area is a black spot, the total number could easily pass 50,000 nation-wide - some of which will contain thousands of homes, others only one or two. The sheer size of a project to identify every black spot across Australia is the stuff bureaucracies (and years of tedious, expensive studies) are made of. Identifying black spots first, and then deciding how to resolve their dilemma, could easily consume 3 to 5 years of bureaucratic work. In that 3 to 5 years, frustrated black spot viewers increasingly will turn to pay-TV delivery while the terrestrial broadcasters are changing over from analogue to digital - and because DTT (digital terrestrial television) covers far less area than ATT (analogue terrestrial television), by the time the bureaucrats have identified the analogue black spots there will be an entire new world of digital black spots to tackle. None of this bodes well for the frustrated TV viewers who could at least be gaining access to the limited services of GWN + WIN (in Western Australia) or Imparja + Central 7 (in the balance of the country) if the ABA would approve their individual requests to become Aurora viewers.

About which the Television Fund paper notes:

"The new regime will retain existing flexibility for the retransmission by self-help groups of terrestrial and satellite-delivered services, both within and beyond the licence area of the originating service (with ABA permission). The new regime will also clarify the ABA's power to approve direct to home (DTH) reception of commercial satellite broadcasting services, beyond the licence area of those services, in order to address black spot reception problems."

Which brings us back almost full circle to some candid admissions in the Fund paper. "There is no simple, uniformly agreed, definition of what constitutes a black spot television reception area." Or, "Operating guidelines for the black spots program will need to address whether black spots funding should be restricted to fixing genuine 'holes' in the coverage

area of a television transmitter, or if a wider definition of black spots should be adopted to cover other cases of poor reception. This may include, for example, where viewers are located on the edge of the primary coverage area of the television transmitter. This will in turn raise the issue of how an acceptable 'quality' of reception should be defined. It may be necessary for operating guidelines to incorporate a technical standard which addresses this issue."

Obviously the Ministry, in creating the Television Fund paper, is some distance from concrete decisions regarding correcting for black spots. Unfortunately, this honesty to admit they don't have either the answers nor a plan to proceed is not stopping the Government from pushing ahead for the early adoption of the BSAB '99 Act "during the spring session of Parliament."

The proposed amendment reads:

Schedule 2 / subclause 7(2), add (2) as follows:

"(2A) Each commercial television broadcasting licence is also subject to the condition that the licensee will not provide commercial television broadcasting services under the license outside the licence area of the license unless:

- a) the provision of those services outside that licence area occurs accidentally; or
- b) the provision of those services outside that licence area occurs as a necessary result of the provisions of commercial television broadcasting services within the licence area; or
- c) both:

- (i) the licensee satisfies the ABA that the provision of those services outside that licence area occurs in exceptional circumstances; and

- (ii) the ABA has given permission in writing; or

- (d) all of the following subparagraphs apply:

- (i) the first-mentioned licensee satisfies the ABA that there is a person (the **eligible person**) who is in a commercial television broadcasting licence area (the **second licence area**) that is not the same as the first-mentioned licence area and who is not receiving adequate reception of a commercial broadcasting service provided by a commercial television broadcasting licensee for the second licence area;

- (ii) the provision of the first-mentioned services outside the first-mentioned licence area occurs only to the extent necessary to provide adequate reception of the first-mentioned services to the eligible person;

- (iii) the ABA has given permission in writing."

Obviously, interesting days - and years - are ahead.

## small, medium and LARGE C and Ku antennas in stock!

Transmit and receive antennas from 1.2m to 13m (Intelsat Standard B). Linear and circular feeds (AsiaSat, Palapa, JcSat, Rimsat, PanAmSat, Intelsat and more) for transmit and receive-only applications. Receive and transmit electronics including inclined orbit tracking equipment with motor drives for elevation and azimuth to 50 tons. Complete system design, fabrication, installation + proof of performance.

P  
A  
C  
I  
F  
I  
C



A  
N  
T  
E  
N  
N  
A  
S

### Pacific Antennas Limited

Bryon G.G. Evans, PO Box 265, Whangaparaoa, NZ  
Tel/fax 64-9-424-0841 • Mobile 025-789-160

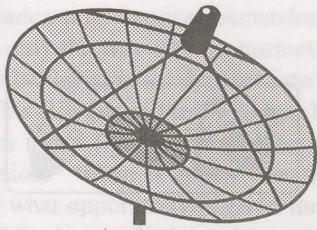

# AV-COMM SATELLITE TV EQUIPMENT

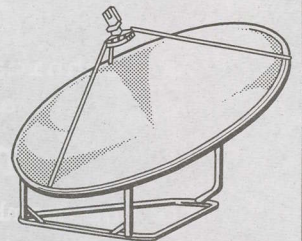

## FREE TO AIR DIGITAL SATELLITE RECEIVER R3100

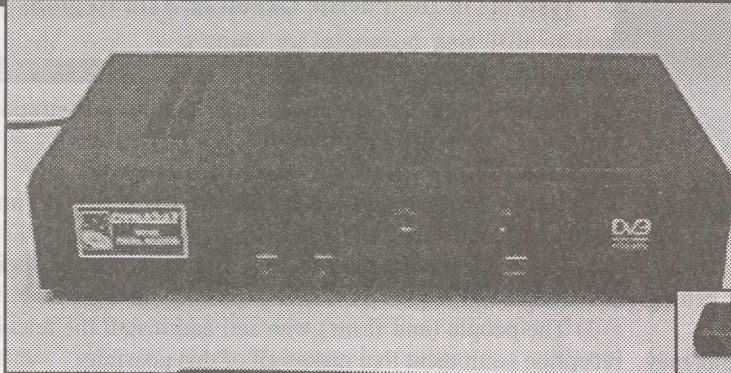

Cat # R3100

ONLY  
**\$1145**

Call  
for  
export  
price

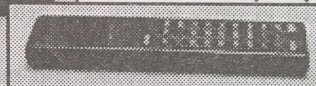

### FEATURES

- ◆ 950-2150 extended frequency coverage, C & K band
- ◆ 14/18V LNB polarity selection
- ◆ MCPC & SCPC
- ◆ 22KHz tone switching for dual input ops.
- ◆ Downlink signal margin indicator
- ◆ Dual channel audio
- ◆ Channel "edit" facility
- ◆ 0-12V output for dish selection
- ◆ S-VHS video output
- ◆ Auto FEC detect

## DYNALINK MANUAL TUNED RECEIVER R1100

### SPECIFICATIONS

- ◆ 950 - 2050MHz IF Input range
- ◆ Low threshold operation
- ◆ Stereo audio
- ◆ 14/18V LNB switching
- ◆ 18/27MHz IF Bandwidth.

Ideal for band scanning, channel monitoring, or as the heart of any home satellite receiving system.



ONLY  
**\$199**

Call for  
export price

Cat # R1100

## AV-COMM PTY. LTD.

DIRECT IMPORTER ACN 002 174 478  
PO BOX 225, BALGOWLAH 2093

TEL: 61 2 9949 7417 9948 2667

FAX: 61 2 9949 7095

VISIT OUR WEB SITE AT

<http://www.avcomm.com.au>

\*We reserve the right to improve product performance without notice.

✓YES GARRY, Please send me more info...

Name: \_\_\_\_\_

Address: \_\_\_\_\_

\_\_\_\_\_ P'code: \_\_\_\_\_

Phone: \_\_\_\_\_

a technical and marketing  
advisory  
**memo**  
to the membership from your  
industry trade association

## SPACE Pacific

Satellite  
Programme  
Access  
CommittEe



A trade association for users, designers,  
installers, sellers of private satellite-direct  
systems in the Pacific Ocean & Asia Regions

### Playing politics

For most citizens, laws are made by elected officials (or by bureaucrats hiding behind some regulatory scheme) and the process of how a proposal turns into law is foreign and mysterious. Setting aside the live coverage of Parliament on ABC-TV (and Parliament radio on Aurora), most of what we hear or are told about is cloaked in party loyalty and getting something down and dirty on "the other side."

Some proposed laws cut across party platforms and may actually have few opponents. The proposed Broadcasting Services Amendment Bill (No. 1, 1999) *should be* such a proposal. The new Bill is a near carbon copy of an offering of the same name from 1998, a bill that lapsed into obscurity within the calling of the most recent Federal Election. "Near carbon copy" but not quite. There are important additions which deal with the recent revelations by the ABA that this agency does not (now) believe it has the authority to approve "out of market/region DTH reception" for would-be subscribers to Imparja and/or Central 7. We, more than any other group, have been badly shaken by a sudden reversal in late June that saw routine approvals for Imparja and Central 7 shut down. The ABA advised Imparja and Central 7 that viewers who live inside of a paper predicted coverage region of another station (such as WIN-TV) would no longer be granted "special approval" for DTH reception, almost simultaneously to the Second Reading of the 1999 Bill.

Mr McGauran (Gippsland, Minister for the Arts and the Centenary of Federation) speaking to Parliament on June 28th, told the members -

"The government has consulted widely with all relevant interest groups on the proposed retransmission arrangements, and on associated provisions to protect regional broadcasters from the rebroadcast of programs on regional pay TV services,

which are substantially similar to prime time metropolitan television programming."

There are three "interest groups" in this action:

- 1) The terrestrial television broadcasters who fear the arrival of competition from satellite delivered programming,
- 2) The residents of homes located in areas served by regional broadcasters,
- 3) The people (and firms) who sell and install the television reception equipment that makes all of this possible.

The third group is us, you and me. Do you recall being "consulted" (widely or otherwise) by anyone prior to the introduction of the Broadcasting Services Amendment Bill? Thought not.

Every year there are several thousand bills considered, and a few hundred manage to attract serious interest. The difference between a bill that is well thought out but left to lapse or never even make first reading - and a bill that goes through the process of debate and vote - is public interest. Or, private interest. Public interest serves everyone - or a wide body of the populace. Private interest serves a narrow group or even a single individual or firm. Public attracts wide spread interest, private tends to be buried out of public view and is the stuff that competitive political parties salivate to dig out and bring to public view in hopes of embarrassing the party in power.

Each of you has a Member in Parliament. He or she appeared by name on the ballot you studied when voting. This person is your link to Parliament. If your Member is a current and up to date person, there will be an Internet Web site with their name on it. Most such Web sites have a feature to allow sending of e-mail to the Member. Unless you are already on a first name basis with your Member and can pick up the telephone to gain his or her ear, using the e-mail input system is by far the best way of making your Member aware of your concerns about a pending piece of legislation.

## MEMBERSHIP IN SPACE

Membership in SPACE Pacific is open to any individual or firm involved in the "satellite-direct" world in the Pacific and Asia regions. There are four levels of membership covering "Individuals," the "Installer/Dealer," the "Cable/SMATV Operator," and the "Importer/Distributor/Programmer."

All levels receive periodic programme and equipment access updates from SPACE, significant discounts on goods and services from many member firms, and major discounts while attending the annual SPRCS (industry trade show) next March. Members also participate in policy creation forums, have correspondence training courses available. To find out more, contact (fax) 64-9-406-1083 or use information request card, page 34, this issue of SatFACTS. Page space within SatFACTS is donated each month to the trade association without cost by the publisher.



This issue of SatFACTS contains several reports devoted to the pending legislation (see p. 1, 14, and 22 as well as here). Each of these presents a different perspective on how the Broadcasting Services Amendment Bill (1999) might affect not only the way you do business but the way your customers watch television for decades into the future.

This Bill can in theory appear before Parliament at any stage from today (August 9th in fact) until the end of the "Spring Session." When it appears on the floor, how it is presented, and what opportunity is given for serious input to be voiced by all Members will depend largely on how the Government of the day views its chances for success.

This is a technical Bill. It does not create a new law, it modifies an existing law (from 1992 - the original Act to be modified). When you study the proposed new Bill, it only makes full sense if you have open before you a copy of the 1992 Act since the new Bill's language is written around "delete paragraph this and substitute paragraph that." The Bill deals with far more than simply redefining DTH coverage areas - and of all that it tries to fix, DTH coverage areas are at the bottom of the list for most Members of Parliament because this procedure is almost impossible to understand for anyone outside the ABA, the television broadcaster's club, and the satellite DTH industry. For example - also in the Bill and sure to attract interest - a requirement that cable (and satellite) firms picking up and carrying free to air terrestrial signals first have the written approval of the broadcaster. And, a section dealing with clarifying some of the regulations found in the Copyright Act of 1968 as the new satellite and cable technologies require. And a change in law that would prevent broadcasters such as 9 from buying up sport event coverage rights and then sitting on those rights and denying the public access to the event at all.

The opportunity to actually influence the outcome of a Bill such as this is not great, but the situation is by no means hopeless. The first step is to gain access to the Member representing you and your district. The second step is to try to educate him or her on why some aspects of the proposed legislation may not be good for the district. The third step is to gain publicity for your views. One way to do this is to spend an hour with a reporter for a local or regional newspaper, explaining what is at stake here and why a wrong decision in 1999 could have significant impact on TV viewing options as soon as 2001 - when DTT (digital terrestrial television) launches.

We cannot and will not tell you what you should say or how you should say it. That is up to you to decide based upon the best information you can locate to study the likely problems facing television reception. What we will suggest is this. The decisions about to be made will cast into stone technical standards which will outlive most of us. There is at least a chance that the approach of the Broadcasting Services Amendment Bill (1999) is based upon faulty reasoning, faulty engineering studies or both.

If COFDM terrestrial TV (see p. 22) is not the best choice for Australia, the only way out of that decision after 2001 will involve junking every new digital TV set built and sold for COFDM reception and starting all over with something more appropriate to the Australian environment. Members of Parliament should be made aware that their "vote" for something this complex and technical should not be done without adequate opportunity to hear alternative views. Mistakes made here will be expensive and difficult to correct.

## Your IRD should be set-up to receive



where **SPACE Pacific Report** appears 8 times each weekend - your industry's one hour "television report" produced for your information!

**Saturdays:** 00:30UTC/12.30NZ/10.30AE/08.30AWA; 15.05UTC/03.05NZSun/01.05AE Sun/23.05AWA Sat.; 19.05UTC /07.05NZ Sun /05.05AE Sun /03.05AWA Sun; 22.30UTC/10.30NZ Sun, 08.30AE Sun, 06.30AWA Sun. **Sundays:** 04.00UTC/16.00NZ/14.00AE/12.00AWA; 09.10UTC/ 21.10NZ/19.10AE/17.10AWA; 17.10UTC/05.10 NZ Mon, 03.10 AE Mon, 01.10 AWA Mon; 21.25UTC/ 09.25 NZ Mon, 07.25AE Mon, 05.25AWA Mon.

### Tuning Parameters:

3940/1210Vt/26.655/ 2/3 Video PID 35, Audio PID 36, PCR PID 35 (see full tuning instructions p. 31 here)

PUT STAR POWER  
ON YOUR SIDE!

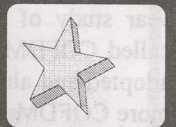

**Star VIVA Cinema (Filipino)**  
**NOW** available outside of Australia  
as well as throughout Australia!

**Star India News**  
India's MOST watched and MOST popular  
24 hour news channel  
(Hindi and English)

### C-BAND SUBSCRIPTION TV

available to your DTH customers through exclusive license granted by Star TV Asia including Star TV decoders and smart cards. Inquiries sought from established, creditable satellite installers/retailers only.

Bill Kahn, **Solution 42 Pty Ltd.**, PO Box 461, Ingleburn NSW 2560 Phone 61-2-9820-5962; Fax 61-2-9820-1769, Mobile 0411 122 427

# The CABLE Connection

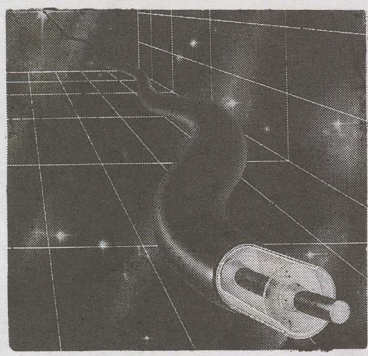

## Selecting the best digital terrestrial TV standard

During July something quite unexpected happened in the United States. Two years after the television broadcast industry and the federal regulators made an informed decision about which standard would be utilised to transmit digital terrestrial television, a panic attack has swept the industry. What is most unusual is that as we write these words more than 60 brand new digital TV stations are now operating and another 110 are planning to operate as soon as their construction is completed (by the end of this year). Already several billion (US) dollars have been spent to allow TV stations to change over from analogue to digital.

The panic attack involves the now three year old decision to utilise something called 8-VSB transmission protocol. This format, developed by American firm Zenith, creates the precise method of marrying digital data streams to a transmission carrier. If you understand how analogue works, 8-VSB is the "FM" part of analogue.

Four different "modulating techniques" were considered in the States, each had advantages and disadvantages. A late entry, developed in Europe and not available during the five year study of modulation techniques until the very end, is called COFDM. It is the COFDM technique which has been adopted and already put into operation in Europe; the UK has more COFDM operating today than all of the rest of the world put together. Australia is testing with COFDM, has made a formal decision to use this modulation technique when HDTV (high definition television) is launched there commercially in 2001. Standards New Zealand, a quasi-official but not Government run agency, has voiced its approval for COFDM as well. There is another name for COFDM - one preferred by Australia and New Zealand technical people - they call it DVB-T.

A major television broadcaster, Sinclair, in the States has installed a COFDM transmitter in Baltimore along side their pre-existing 8-VSB transmitter. The two can operate simultaneously and every care has been taken to ensure that in terms of transmission power, the two are equal. Sinclair believes the American decision selecting 8-VSB may have been a mistake. Their side by side demonstrations hope to provide a test bed where the issue can be re-examined.

Meanwhile, the 60 (and growing) 8-VSB format transmitters have been battling a puzzle. Areas close in to the transmitters, where the signals are strong, are having significant problems resolving a digital image with sufficient quality to get above the bit error rate threshold. Plenty of signal, and, plenty of errors. The 8-VSB format TV receivers are simply rejecting the digital data stream because of corrupted data bits. The

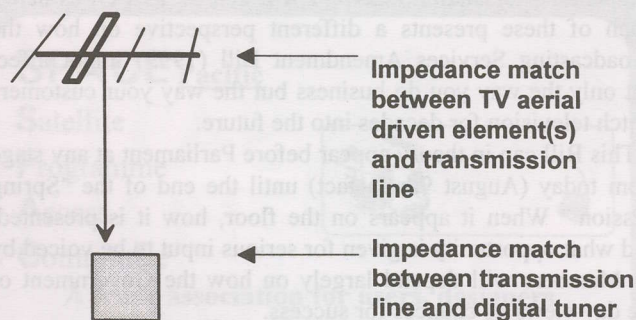

problem has been traced to multi-path reflections. Strong signals, to the point of overloading the sensitive DVB-T receiver terminals, are arriving at the TV set location by multiple routes. Signals travel directly from transmitting antenna to the receiving antenna, and simultaneously, hop, skip and bounce from tall buildings, metal roadway signs, concrete walls and sheets of tinted glass to the receiving location. Some of these hop-skip-bounce signals arrive significantly delayed in time from the direct signal. "Significant" in the case of DVB-T is 0.2 microseconds - that is enough to make the data bits in the data stream "overlap" inside of the receiver. Just as the receiver is processing a "1-0-1" sequence here comes a slightly weaker and delayed in time "0-1-0" sequence. The DVB-T receiver is confused by two sets of instructions, cannot sort it

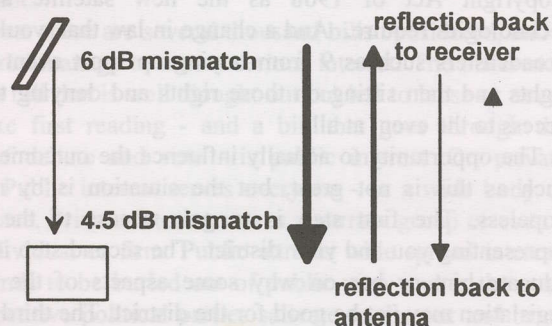

out, and goes into a shutdown mode. As a satellite professional, you recognise this symptom - pixelation when a signal is on the edge and then a freeze frame and lockup of the image.

COFDM, on the other hand, has been demonstrated to handle these delayed or echo signals with better results. The answer - and there is one - is multi-layered. If the receiving site installs an outdoor antenna of appropriate "digital quality," the echo or delayed signals are reduced if not eliminated. Unfortunately, when you live in a high rise building in New York City (or Baltimore) and the "roof" where your TV antenna would go is 300 feet above you, installing your own dedicated "digital quality" TV antenna may not be an option. This is a serious problem for metropolitan would-be digital TV watchers. Sinclair, the people running the tests, say "This is not acceptable." They mean - "8-VSB was a mistake and we should stop right now and convert to COFDM." With billions of dollars already invested in 8-VSB transmission facilities, and digital TV receivers rolling off the production lines in increasing quantity, this is a tough pill to swallow. There may be an alternative - but if there is, it has not happened yet. And that would be "better software" in the DVB-T receivers, capable of distinguishing between the "real" signal and the "echo" signals and eliminating the false ones. DVB-T receiver

manufacturers (such as Sony) don't yet claim they *will* be able to do this, and that is worrying the US TV broadcasters who have years of work and billions of dollars invested in 8-VSB.

There is a flip side. 8-VSB may be a challenge close in to the transmitter sites, but everyone - even the British who champion COFDM - agree it is superior to COFDM for long haul fringe area reception. 8-VSB in our satellite language is akin to a satellite signal with an FEC of 1/2. COFDM is akin to a satellite signal with an FEC of 7/8. We all know what that means - FEC 1/2 works to smaller antennas, or in the terrestrial world, travels further before pixelating. This would be a good point to remind you that Australia will use COFDM, New Zealand says they plan to. COFDM works in the UK because over the decades of TV development, main stations and relays have been situated such that virtually no area is more than 40 km from a relay station. COFDM works quite well to 40 km; 100 is quite out of the question. In the USA, TV stations build huge towers (2,000 feet is not unusual) and cover very large circular regions - often as much as 300 km across (or from the station, out to a point 150 km distant). Australia's "fringe" areas - as well as those in New Zealand, where signals are already weak and degraded on analogue will simply disappear totally with COFDM. Think of it this way - the present analogue coverage is like FEC 1/2 service; when the digital turns on and attempts to cover the same region, the FEC will jump to 7/8. The fringe areas will move in - British experience suggests it will shrink by no less than 20% (or 8 km if the analogue coverage is a 40km circle).

And there are other problems related to "echoes." Terrestrial TV aeriels are basically low tech devices put together by firms with spare time on their aluminium lawn chair production lines. Real engineers with degrees in antenna physics are as

rare in lawn chair production facilities as real politicians who pay for their own lunches.

Because 8-VSB is so sensitive to echo signals, the American TV aerial industry has gone through a revolution during the past 12 months. Real engineers with real degrees have been hired to sort out what is happening to the delicate 8-VSB signal as it flows over the rooftop aerial and offers some of its precious energy to the attached transmission line. The answers are not revolutionary but a reminder that analogue was pretty damned forgiving! As we show on the opposing page, if there is an impedance mismatch between the transmission line and the TV set tuner, some of the energy (we show a 4.5 dB mismatch) is refused passage to the tuner. It goes backwards (is reflected) towards the TV antenna. If there is also a mismatch between the transmission line and the antenna (we show a 6 dB mismatch), some of that energy is rejected by the antenna as well and it flows again to the tuner. By bouncing from antenna to tuner to antenna and back to the tuner - transit time is added to the signal. This creates an echo - a *delayed* signal. Which compounds the 8-VSB DVB-T receiver's decision to accept or reject the data stream it is given. A 30 metre transmission line between antenna and receiver adds around 0.2 microseconds delay (echo) to the data stream. Worse yet, the echo keeps recycling until after four or five up and down trips it runs out of steam. And since the data stream is constant, there is a never ending circle of energy flowing in both directions because of antenna-transmission line-tuner mismatches. In effect, multi-path is built into the antenna-transmission line - digital tuner system!

All of this strongly suggests terrestrial digital television has a long ways to go before it is successful under the same conditions as analogue is today. Welcome to the 21st century.



# MELBOURNE SATELLITES P/L

ACN 065 270 733

Established 1992

Direct importers and suppliers of the following world renown products.

**KTI**  
**ORBITRON**  
**PATRIOT**  
**JONSA**  
**ANDREW**

**ECHOSTAR**  
**SCIENTIFIC ATLANTA**  
**NOKIA**  
**IKUSI**  
**DX**

**GARDINER**  
**CALIFORNIA AMPLIFIER**  
**MTI**  
**CHAPARRAL**  
**ADL**

Full range of cables, splitters and connectors.

Phone, fax or write for our 1999 Product SATalogue.

Sales/Warehouse - 84 Bayfield Road, Bayswater Victoria

Construction Services - 13 Elsum Avenue, Bayswater Victoria

Postal Address - PO Box 901, Bayswater 3153 Victoria Australia

Phone: (03) 9738 0888

Fax: (03) 9729 8276

User Friendly Site!

[www.melbournesatellites.com.au](http://www.melbournesatellites.com.au)

e-mail: [sales@melbournesatellites.com.au](mailto:sales@melbournesatellites.com.au)

# SatFACTS Pacific/Asian MPEG-2 Digital Watch: 15 August 1999

BIRD	Service	RF/IF & Polarity	# Program Channels	FEC	Msym	
I703/57E	Sky News	4143/1007R	1	3/4	5(.632)	
	CNBC	4018/1132L	1	3/4	6(.000)	
I704/66E	TV5. Adult 21	4055/1095R	4	3/4	27(.500)	
	Sky News +	3805/1345R	4	3/4	22(.520)	
PAS4/68.5E	Nickelodeon +	4147/1003H	1 reported	1/2	24(.000)	
	BBC	3743/1407H	5	3/4	21(.800)	
	CCTV	3716/1434H	up to 6	3/4	19(.850)	
Ap2/76E	HMark/Kermt	3720/1430H	4	5/6	29(.270)	
	TVB-8 +	3849/1301H	4	3/4	13(.238)	
	Disney	3880/1270H	3	5/6	28(.125)	
	AXN	3920/1230H	up to 8	7/8	28(.340)	
Thcm3/78.5E	ITC	3569/1581H	1	3/4	10(.200)	
	MRTV	3666/1484H	1	2/3	4(.442)	
	UTV	3920/1230H	6	3/4	26(.662)	
	UTV/MCOT	3880/1270H	8	3/4	27(.500)	
	Mahar./DD1	3600/1550H	up to 8	3/4	26(.662)	
	Myanmar TV	3666/1484H	1	3/4	4(.442)	
	TV Maldives	3412/1738V	1	1/2	6(.312)	
	Thai Global +	3425/1725V	up to 7	2/3	27(.500)	
	As2/100.5E	Euro Bouquet	4000/1150H	6TV,12r	3/4	28(.125)
		Hubei/HBTV	3854/1296H	1	3/4	4(.418)
Hunan/SRTC		3847/1303H	1	3/4	4(.418)	
Guan./GDTV		3840/1310H	1	3/4	4(.418)	
Inn Mongolia		3828/1322H	2	3/4	4(.418)	
Saudi Arabia		3811/1339H	1	3/4	3(.905)	
APTN A-O		3799/1351H	1	3/4	5(.631)	
WTN Jer/Lon		3790/1360H	1	3/4	5(.631)	
Reuters/Singap		3775/1375H	1	3/4	5(.631)	
WorldNet		3764/1386H	1 + 20 radio	3/4	6(.100)	
Liaoning/Svc2		3734/1416H	1	3/4	4(.418)	
Jiangxi/JXTV		3727/1423H	1	3/4	4(.418)	
Fujian/SETV		3720/1430H	1	3/4	4(.418)	
Hubei TV		3713/1437H	1	3/4	4(.418)	
Henan /Main		3706/1444H	1	3/4	4(.418)	
As2/100.5E		TVSN	4033/1117V	1	3/4	4(.298)
		Sky Racing	4020/1135V	3?	1/2?	18(.000)?
	EMTV	4006/1144V	1TV, 2radio	3/4	5(.632)	
	KIBC	3940/1210V	1TV, 4 data	2/3	26(.655)	
	Jilin Sat Ch	3875/1275V	1TV	3/4	4(.418)	
	HeiLongJiang	3834/1316V	1	3/4	4(.418)	
	JSTV	3827/1323V	1	3/4	4(.418)	
	Anhui TV	3820/1330V	1	3/4	4(.418)	
	Shaanxi/QQQ	3813/1337V	1	3/4	4(.418)	
	Guang GXTV	3806/1344V	1	3/4	4(.418)	
	Fashion TV	3796/1354V	1	3/4	2(.533)	
	Feeds	3785/1365V	1	3/4	5(.632)	

Receivers and Errata
NDS encrypted; often FTA
Feeds-FTA SCPC
FTA (Adult 21 off air???)
Sky News 24 hr, sport, feeds FTA?
Ws testing FTA - still active???
FTA; 2 audio channels?
FTA
PowVu typ CA
PowerVu CA
PowVu CA
Tests, promos, some FTA
FTA
FTA; difficult to load
Irdeto CA
Irdeto CA
FTA (Indian, Skai-TV)
FTA - may be only test
FTA (seen Australia)
FTA
FTA (TV5 teletext)
FTA SCPC, teletext
FTA SCPC, teletext.
FTA SCPC; radio APID 81
FTA - #1 Chinese, #2 Mongolian
FTA SCPC - "Ch. 1"; also 3661V
FTA SCPC
Mostly CA SCPC, some FTA
Some FTA SCPC
FTA, multiple radio channels
FTA SCPC
FTA SCPC; teletext
FTA SCPC, radio
FTA SCPC
FTA SCPC, radio
FTA SCPC - difficult
Now Irdeto; 1 & 3 occ. FTA
PowVu CA-very poor signal level
FTA 1 video ch; ZakNet data CA
FTA SCPC, radio
FTA SCPC
FTA SCPC, radio
FTA SCPC
FTA SCPC
FTA SCPC
(remains) FTA-difficult to load
Was Eastern TV - now SCPC feeds

BIRD	Service	RF/IF & Polarity	# Program Channels	FEC	Msym
(As1-cont)	Myawady TV	3766/1384V	1	7/8	5(.080)
	Saudi Ch 1	3661/1489V	1	3/4	7(.128)
As3S/105.5E	Arirang TV	3755/1395V	1	7/8	4(.418)
	Star TV	3780/1370V	17TV?	3/4	28(.100)
	Star TV	3860/1290V	14 TV	3/4	27(.500))
	Star TV	3880/1270H	12TV	7/8	26(.850)
	CNNI	3960/1190H	4(+?) TV	3/4	26(.000)
	Star TV	4000/1150H	7TV	7/8	26(.850)
Cak1/107.1E	Indovision S-band	2.536, (.566, .596, 2.626)	33+	5/6	20(.000)
Sinoat 1/110E	Shanghai	4106/1044V	1	2/3	4(.443)
C2M/113E	Space TV	4000/1150H	11	53/4	26(.655)
	Mega TV	3780/1370V	5?	3/4	27(.500)
	C Net Taiwan	3760/1390H	11TV, 10 r	5/6	21(.091)
	RCTI	3475/1675H	1	3/4	8(.000)
JcSat3/128E	Trinity Best	3990/1160V	1	3/4	5(.026)
LMI API/130	THT	3725/1425L	1 (PAL format)	3/4	6(.108)
AP1A/134E	Gansu TV	3769/1381V	1	1/2	6(.930)
AP1/138E	Reuters	3742/1408V	1	3/4	5(.632)
	Viacom	3860/1290V	up to 6	3/4	30(.000)
	SDTV	3980/1170V	1	3/4	4(.686)
Optus B3/156	Mediasat	12.336V	5+TV, 3+ rad.	2/3	30(.000)
Optus B3/156	Aurora	12.595,.720V	17+, 21+ rad.	3/4	30(.000)
	Aurora	12.407,532V	17+, 21+ rad.	2/3	30(.000)
	Austar/Foxtel	12.438(.564, .626, .688)	45+TV, 12 radio	3/4	29(.473)
Optus B1/160	ABC NT feed	12.256V	1TV, 3 radio	3/4	5(.026)
	Sky NZ	12.391,(418)V	19+TV	3/4	22(.500)
	Imparja feed	12.367H	1TV	3/4	5(.424)
PAS8/166E	ABC Interchg	12.332H	1+1+1 TV	3/4	6(.978)
	TARBS	12.524H	10(+TV)	3/4	28(.062)
	NHK Joho	4065/1085H	5 TV, 1 radio	3/4	26(.470)
	Cal Bqt/PAS8	3940/1210H	4 or 5 TV	7/8	27(.690)
	CNN	3780/1370H	3 up to 5	3/4	25(.000)
PAS-2/ 169E	GWN Perth	12.265V	4TV, 7 radio	1/2	16(.200)
	Telstra Bend.	12.300V	2	1/2	21(.997)
(#2)	HK PowVu	4148/1002V	up to 8	2/3	24(.430)
(#3)	NBC HK	4093/1057V	5 typical	3/4	29(.473)
	Feeds	3942/1208V	1 or 2	2/3	7(.497)
	ESPN USA	3860/1290V	7TV, 2 data	7/8	26(.470)
(#4)	Middle East	3778/1372V	4	3/4	13(.331)
	Service 1	3761/1389V	1	3/4	6(.620)
(BBC temp)	BBC + TFC	3743/1407V	5	3/4	21(.800)
(#5)	CCTVPowVu	3716/1434V	5 typical	3/4	19(.850)
	TCS-Singap.	4183/967V	2	1/2	6(.620)
	NTV Japan	4174/976H	1	3/4	5(.632)
	Feeds	4138/1012H	1	3/4	6(.620)
	CNNI HK	3996/1154H	1TV	3/4	9(.998)
	Feeds	3967/1183H	1+	2/3	6(.618)
	7th Day Adv.	3957/1193H	1, 14 audio	3/4	7(.000)
	PAS-2 feeds	3939/1211H	2 (NTSC)	2/3	6(.620/7.498)
(#8)	Cal PowVu	3901/1249H	up to 8	3/4	30(.800)

Receivers & Errata
FTA SCPC - difficult
FTA SCPC; also see3811V
FTA SCPC - strong!
NDS CA (Pace DVS211)
NDS CA (Pace DVS211)
NDS CA (Pace DVS211)
PowerVu-some FTA chs
NDS CA (Pace DVS211)
RCA/Thomson IRD. Now more dependable operation
FTA SCPC-difficult to load
temp FTA, inc. adult porn
unknown encryption format
all TV now CA but subs available
FTA SCPC
Trinity test feed to Asia - Pv FTA
typ. 0500-2100UTC, FTA Russian
FTA SCPC
FTA SCPC
FTA & CA MCPC
FTA SCPC
PowVu, TRT /Maharishi FTA
CA, \$50 smart card required
CA, \$50 smart card required
DGT400 CA except FTA TVSN and radio
FTA SCPC, Sydney - 30 minutes
NDS CA, 12.391 primary
backhaul feed/ hard to load
+12.324, .315 (was PAS-2 Ku)
CA announced for July 15
1CA (D9234),, 4 FTA
mixed CA + FTA (EWTN)
PowVu, temp FTA
PowVu CA (D9234)
PowVu typ. CA (D9223 only)
PowVu, mostly CA, some FTA
Philips mux format FTA
FTA occ. feeds
PowVu CA; #12 bootloader
FTA -hard to load
occ feeds, FTA SCPC
PowVu; CA and FTA (BBC#3)
FTA (# pgm chs varies)
PowVu FTA/snews ch coming
FTA SCPC feeds (occasional)
FTA SCPC
FTA - occasional feeds
FTA - World Cup Cricket
1900-2030UTC, not daily
FTA (NBA , shuttle-typ NTSC)
Some CA, some FTA ( NTSC)

## SatFACTS Digital Watch: Supplemental Reference Data / August 1999

PAS-2/169E	Disney	3804/1346H	3	5/6	21(.093)
	Discovery Sing	3776/1374H	8	3/4	21(.093)
	Satcom 1-6	3743/1407H	5	7/8	19(.465)
I702/177E	AFRTS	4177/973L	8TV, 12r.+	3/4	26(.694)
inactive?	Thai Bouquet	12.650H	up to 3 TV	1/2	17(.800)
I701/180E	TVNZ Gennet	4195/955R	1 (CA)	3/4	5(.632)
		4186/964R	BBC/Gennet	3/4	5(.632)
		4178/972R	1 (CA)	3/4	5(.632)
		4170/980R	APT-N-Tokyo	3/4	5(.632)
	AFRTS Pac.	4175/975L	3 radio	2/3	3(.679)
(#9)	RFO-Canal+	4095/1055L	7TV, 5+ radio	3/4	27(.500)
	SPN Nauru	4081/1069R	1	3/4	4(.730)
	NZ Prime TV	4024/1126L	1	2/3	6(.876)
	RFO Polycast	3858/1292L	1	3/4	4(.566)
	TVNZ TL	3854/1293R	1	3/4	5(.632)
	TVNZ	3856/1294R	1	3/4	5(.632)
	TVNZ	3846/1304R	1	3/4	5(.632)
	10 Australia	3765/1385R	6	7/8	29(.900)

PowVu (D9234) CA
PowVu (D9234) CA
currently Middle East (4 chs)
PowVu (D9234) CA
FTA, replaced Space TV
DMV/NTL CA, all channels occ. use, <b>FTA irregular</b> around special event coverage
PowVu, CA audio (3 chs.)
Canal + (2) CA, rest FTA
FTA SCPC; weak signal
PowVu CA; network feeds
East hemi beam to Tahiti
SCPC mixed FTA, CA feeds
SCPC mixed FTA, CA feeds
SCPC mixed FTA, CA feeds
PowVu CA; #3 TBN

**Bouquets:** MCPC (multiple [program] channels per carrier) MPEG-2 content frequently changes. Primary FTA (free to air) MCPC bouquets are as follows: 1) European Bouquet: (1) **Deutsche Welle**, (2) **MCM**, (3) **RAI International**, (4) **RTVE** (Spain), (5) **TV5 Paris** + up to 17 radio (some stereo) - see p. 2 ; 2) Hong Kong PowVu: (5) **Ad Hoc NTSC feeds**, (6) **Ad Hoc PAL feeds**; (3) **NBC HK** (Hong Kong): (1) **CNBC Asia**, (2) **CNBC Australia**, (3) **Test card** (4) **CNBC India**, (5) **Test card**, (6) **Occ feeds**, (7) **CNBC test card-feeds**; (4) **Middle East** [testing]: (1) **Antenne 1**, (2) **Lebanon LBC**, (3) **ART Australia**, (4) **RAI Australia**; (5) **CCTV PowVu**: (1) **CCTV4**, (2) **CCTV3**, (3) **CCTV 9**, (4) **test bar**, (5) **CCTV1**; (7) **NHK JoHo**: (1) **NTSC Japanese**, (2) **NTSC English**, (3) **PAL Japanese**, (4) **PAL English**, (5) **NHK Radio**, (6) **NHK Premium**; (8) **Cal PowVu**: (1) **CMT [NTSC]** (CA 01/07), (2) **Ad-hoc/CBS [NTSC]**, (3) **BBC[NTSC]**, (4) **NAPA card, feeds** . (5) **Ad hoc feeds**, (6) **Bloomberg Financial [NTSC]**, (7) **Golf Channel [NTSC]**, (8) **MTA**; (9) **RFO-Canal+**: (1) **Canal+ [Polynesia]**, (2) **Canal+ [New Caledonia]**, (3) **test**, (4) **test**, (7) **TOM1**, (10) **TOM2**, (13) **TOM3** + radio on 5,6,8,9,11,12,14,15. **NOTE:** In digital listings, **bold face** denotes FTA or partly FTA.

### MPEG-2 DVB Receivers: (Data believed accurate; we assume no responsibility for correctness!)

**ADI MediaMate.** FTA, NTSC-PAL outputs. (Pacific Digital Sys. Pty Ltd, tel 61-2-8765-0270)  
**AV-COMM R3100.** FTA, excellent sensitivity (reviewed SF May 1998). Av-Comm Pty Ltd., tel 61-2-9949-7417  
**Grundig DTR1100.** Mfg by Panasat S. Africa, similar to Panasat 630; out of production, Irdeto capable (see AV-Comm, above)  
**Hyundai-TV/Com.** HSS-100B/G (Pacific) and HSS-100C (China) FTA. Versions 2.25/2.26 good performers, 3.11 later offered and those with Nokia tuners good performers. Version 5.0 not so good. SATECH ([V2.26] 61-3-9553-3399), Skandia ([V3.11] 61-3-9819-2466).  
**Hyundai HSS700.** FTA, PowerVu, search, SCPC/MCPC. (Kristal Eletronics 61-7-4788-8906) [review March99]  
**MediaStar D7.** FTA, preloaded with known services, exc. software (review SF July 1998). MediaStar Comm. Int. (61-2-9618-5777)  
**Mulichoise (UEC) 660.** Essentially same as Australian 660, not "grey market" contrary to reports. Sciteq (tel 61-8-9306-3738)  
**Nokia "d-box" (V1.7X).** European, FTA, typically German menu, capable of "Dr. Overflow" Internet updates. **Caution on this one!**  
**Nokia 2000S (Asia/Pacific).** Released Oct. 1998; equipped with CAM/PCMCA slot, capable of Irdeto, others (factory will NOT supply CAMs at this time); no Asia-Pacific sources known at this time (but readily available through European sources); review 11/98.  
**Nokia 9200/9500/9600/9800.** FTA, factory software does PowVu poorly, but has significant Internet software support. Ultimate play-around hobby machine but not consumer friendly. Original V1.63 had unique ability to search entire satellite to locate and list all SCPC/MCPC services; latest (V5.X software) versions compatible with Dr. Overflow (V8.X) software from Internet. CI (common interface) versions available in Europe can be Irdeto compatible. No Pacific/Asia support; help from Av-Comm (61-2-9949-7417), and software from www.BAKKERELECTRONICS.COM. 9800S single chip released mid-May 1999.  
**PACE DVS-211.** NDS CA only (no FTA); Indovision, Star TV Asia. (Viva, Star News to Aust - Solution 42 61-2-9820-5962)  
**PACE DGT400.** Original Galaxy (now Foxtel Sat/Austar) IRD, Irdeto, FTA with difficulty. (Foxtel Australia 1300-360818).  
**PACE DVR500.** Original NBC affiliate IRD; FTA or Irdeto (w/CAM). Similar to DGT400, more reliable. No sources.  
**PACE "World Box." (DSR-620)** Created for NDS non-DVB compliant MPEG-2, including Sky NZ. Info, ++49-211-526-9833.  
**Panasat 520/630/635.** MCPC FTA, Irdeto capable. Out of production; spares from UEC (fax ++27-31-593-370.)  
**Panasonic TU-DS10.** FTA, Irdeto CA. (see SF Aug. 1998). Aurora, (Evcom 61-2-9316-5055),  
**Phoenix 111 & 222.** FTA, PowVu. Exceptional graphics, ease of use. (SATECH 61-3-9553-3399) (111 review May 1999)  
**Phoenix 333.** FTA MPEG-2, analogue, positioner. Detailed review SF Nov. 1998. (SATECH 61-3-9553-3399).  
**PowerCom.** FTA, PowVu, exc. sensitivity. (NetSat 61-2-9687-9903)  
**PowerVu /PowVu D9223, 9225, 9234.** Non DVB compliant proprietary format capable MPEG-2 FTA with optional software. 9234 sold for GWN and NHK Joho PAS-2, EMTV As2, CA access; others for various CA services. (Scientific Atlanta 61-2-9452-3388)  
**Praxis DigiMaster 9600 MKII/9800AD.** FTA, PowVu + analogue.; (no longer supported in Pacific), was Skyvision - see below)  
**Praxis 9800 ADP.** FTA, PowVu, analogue, positioner. Review December 1998. (no longer supported in Pacific, see Skyvision below)  
**Prosat 2102S.** FTA, NTSC + PAL, SCART + RCA. (Sciteq 61-8-9306-3737)  
**Samsung DSR2400:** FTA, not especially sensitive, newly released in Asia; no common sources.  
**SatCruiser DSR-101.** FTA, PowVu, NTSC + PAL. (Skyvision Australia 61-2-6292-5850; Telsat 64-6-356-2749)  
**SatCruiser DSR-201P.** FTA, NTSC & PAL digital, analogue, positioner. (Skyvision Australia - see above)  
**SK888.** (aka DigiSkan from Sun Moon Star). FTA MCPC, Irdeto CAM capable. (Skandia 61-3-9819-2466)  
**UEC 642.** FTA, Irdeto built-in, for Aurora + Optus DTH. ("Mondec" rack mount industrial version) (Nationwide 61-7-3252-2947)  
**UEC 660.** Aust. Sky Ch. (1 version), Foxtel Aust. (2nd version); (now available for retail users at Nationwide 61-7-3252-2947)  
**YURI HSS-100C.** FTA, rebadged Hyundai V.2.27 software custom to Australia (Nationwide 61-7-3252-2947)

# SatFACTS Pacific/Asian FTA ANALOGUE Watch: 15 August 1999

Copyright 1999: SatFACTS, PO Box 330, Mangonui, Far North, New Zealand (email Skyking@clear.net.nz)

BIRD / Location	RF/IF & Polarity	Service	Errata
I703/57E	3808/1342R	Udaya TV	
	4052/1098R	WorldNet	VOA subcar.
	4178/972L	MTA Inter.	
I604/602/60E	4166/984	feeds	
I704/66E	3765/1385R	Tests	
	4015/1135L	Mongolia	(SECAM)
PAS4/68.5E	3743/1407V	RTPi	
	3864/1286V	BBC World	
	3907/1243H	Sony TV	Hindi
	4034/1116V	Doordan	
	4087/1063H	CNNI	
	4110/1040H	TNT/Cartoon	
	4113/1037V	Series Ch.	
	4182/968H	MTV	
PAS7/68.5E	3470/1680V	Test Signal	
Ap2R/76E	3745/1405V	Vasta Music	P5 NSW
	3760/1390H	TEN tests	
Thaic3/78E	3871/1279H	TVT	
	3760/1390V	Army TV	
	3690/1460V	MRTV	
	3685/1465H	Mynamar	
	3616/1534V	ETN	(name chnge)
	3576/1574V	ATN Bangla	Bengali
	3554/1596V	RAJ Plus	
	3536/1614V	Punjabi TV	unreliable
	3514/1636V	Falak TV	
	3489/1661H	Vasta Music	tests
	3465/1685V	RAJ-TV	
Exp. 6/80E	3672/1478L	TK Rossija	(north only)
Insat2E/83E	3481/1669V	Sun TV	
	3575/1575V	Vijay/Asianet	Aud 5.5/6.6
	3810/1340V	DD1-Tamil	"
	3850/1300V	DD1 National	"
	3930/1220V	DD2 Metro	"
	3970/1180V	Teluga I	"
	3998/1152V	sport feeds	"
	4035/1115V	Sun TV	"
	4060/1090V	Surya/SunTV	"
	4093/1057V	DD7	"
ChiStr1/87.5	3875/1275H	occ. feeds	P4 NSW Ntsc
ST1/88E	3550/1600V	test card	
	3582/1568V	Nila TV	(operational)
CIS S6/90E	3675/1475R	RTR1	P3 NSW
	3875/1275R	Orbita I	
	3916/1234R	RTR II	
	3935/1215R	Orbita II	

MeSat-1/91.5E	3710/1440H	VTV 1,2, 4	
	3880/1270H	RTM-1	
Insat2B/93.5E	4165/985H	India Metro	Aust on 3.7m
	4125/1025V	Ind. National	Aust on 3.7m
	4070/1080H	India DD9	
	4080/1070V	DD7 (Tamil)	
	3970/1180V	DD9 (kan.)	
	3882/1268V	India DD1	
	3840/1310V	India DD	
	3762/1388V	India DD4	
AsSat2/100.5E	3642/1508H	ERTU Egypt	
	3660/1490V	Test Card	
	3680/1470H	Feeds/Iran	
	3860/1290V	Feeds #	
	3885/1265H	WorldNet	VOA Subcar.
	3960/1190H	CCTV4	
	3980/1170V	RTPi	+5 radio svcs.
CIS S21/103E	3675/1475R	RTR	
	3875/1275R	Vrk.Apt	
AsSat3S/105.5	3680/1470H	CETV	
(temp FTA )	3800/1350H	Star Sports	NTSC
(temp FTA)	3840/1310H	Channel [V]	NTSC
(temp FTA)	3920/1230H	Phoenix Chin.	NTSC
	3940/1210V	Zee India	
	3980/1170V	Zee TV	
	4060/1090V	Zee Cinema	(starcrypt)
	4100/1050V	PTV2/World	teletext
	4120/1030V	CCTV4	NTSC
PalB2R/108E	4000/1150H	TVRI	
PalC2/113E	4183/967V	TPI/TVRI	
	4160/990H	(France) TV5	
	4140/1010V	Brunei, feeds	
	4120/1030H	MTV Asia	
	4080/1070H	Herbalife	2100HK/NTSC
	4040/1110H	CNBC	
	3970/1180V	CNNI	(was 3980)
	3900/1250V	Malaysia TV3	CA and FTA
	3880/1270H	Aust. ATN7	
	3840/1310H	TVRI	temporary?
	3765/1385H	NBC, CNBC	Feeds, Herbalif
	3742/1408V	RCTI	English subcar
AsSat-1122E			Now on station
ChinSat 6/125	4085/1065V	feeds	is it really here?
JcSAT3/128E	4085/1065V	test card	NTSC, 6.8
G'zont29/130E	3675/1475L	NTV (+8hrs)	off 1400 UTC
Ap1A/134E	4160/1050V	CETV	

53.2	55	57	66	68.8	76	78.5	80	87.5	88	91.5	93.5	100.4	103	105.5	107.1	108	110.5	1,103	120	(122)
S27	2DT	I703	I704	PAS4 PAS7	Ap2	Th3	Ex2	Cs1	St1	Me-1	In2B	As2	S21	As3S	Ck1	B2R	Ss1	C2	Th1/ 2	As1
C	C	C	C	C	C	C	C	C,Ku	C	C,Ku	C	C,Ku	C	C,Ku	"S"	C	C,Ku	C,Ku	C	C

128	130	134	138	(139)	140	142.5	145	146	148	(151)	152	156	160	166.5	169	174	177	180	177	148
Jc3	AP1	Ap1a	Ap1	Or3s	S7	AP2	S16	Ag2	Me2	C1	A3	B3	B1	PAS8	PAS2	I801	I702	I701	IF3	Es4
C,Ku	C	C	C	C,Ku	C	C	C	C,Ku	C,Ku	C	Ku	Ku	Ku	C,Ku	C,Ku	C	C,Ku	C	C,Ku	Ku

Ap1A/134E	3900/1250V	CETV2	
	3980/1170V	CETV1	
Ap1/138E	4160/990H	CCTV7	
S7/140E	3675/1475R	Test Card	mod. inclined
AP2/142.5E	3675/1475L	Tests	PacSat demo
S16/145E	3675/1475R	ORT	high inclined
	3875/1275R	Feeds, tests	high inclined
Ag2/146E	3787/1363H	GMA	poor s. eqtor
Me2/148E	4080/1070H	test card	occ. use
C1/150E	4160/990H	TPI	occ. use
PAS8/166.5	3865/1285H	Napa test card	not full time
PAS2/169E	3940/1240V	CNNI	1/2 Tr format
I802/174E	4166/984R	Feeds	
	4177/973R	Feeds	
I702/177E	4166/984R	Feeds	KBS Korea
	4187/963R	Feeds	Feeds
I701/180E	3810/1340R	Feeds	
	3841/1309L	RFO	East beam
	3845/1305R	Feeds	inc. USA
	3930/1220R	USA Feeds	Typ. encrypt.
	3975/1175R	Feeds	
	4060/1090L	Feeds	
	4130/1020L	Feeds	

### Major Changes - Next 30 Days

If successfully launched late in August, Telekom 1 at 108E will be replacing Palapa B2R. The advance footprints do not look encouraging for most of Australia - or New Zealand but such predictions are not always accurate. Look for announcement late August of new initiative by Australian Telstra to provide Ku-band satellite Internet downloading via Optus B3 and (this is the interesting part) PAS-8. Installers will find new "work" here as Telstra rolls out direct-to-home data feeds - an answer to the Austar plan to do something similar "late this year."

### Optus B3 at 156E / Ku only

12.720/1420V	Aurora MPEG	Irdeto CA IRD	see p.15,18 May
12.688/1388H	Austar MPEG	Irdeto CA IRD	list p.31
12.626/1326H	Austar MPEG	Irdeto CA IRD	list p.31
12.594/1296V	Aurora MPEG	Irdeto RABS	see p.15,18 May
12.564/1263H	Austar MPEG	Irdeto CA IRD	list p. 31, July
12.532/1232V	Aurora MPEG	Irdeto RABS	see p.15,18 May
12.480/1180V	HBN	Analogue PAL	
12.438/1138H	Austar MPEG	Irdeto CA IRD	list p. 31, July
12.407/1107V	Aurora MPEG	Irdeto RABS	see p.15,18 May
12.366/1066V	Mediasat	PowerVu FTA	see p. 6, Aug.

### Optus B1 at 160E / Ku only

12.730/1430H	RHEF, NZ feeds	typ FTA anal.	occ. use
12.576/1276H	ABC Radio	digital	
12.570/1270V	OmniCast		FM/FM
12.546/1246V	Sky NZ	NDS-MPEG	&12.518(CA)
12.520/1220H	Net 9 feeds	typ. BMAC	
12.518/1218V	Sky NZ	NDS MPEG	& 12.546 (CA)
12.482/1182V	Net 10 feeds	typ. E-PAL	
12.480/1180H	Net 9 feeds	typ E-PAL	
12.455/1155V	Net 10 feeds	typ. analogue	
12.418/1118V	Sky NZ	NDS-MPEG	& 12.391 (CA)
12.391/1091V	Sky NZ	NDS MPEG	& 12.418 (CA)
12.256/956V	ABC NT feeds	MPEG-2	Sydney -30 min

### Oddball Formats

PAS-4/68.8	3785/1365V	Discov. India	BMAC
PAS-4/68.8	3860/1290H	ESPN Indian	BMAC
Ap2/76E	3960/1190H	HBO Asia	GI Digiciph2
C2/113E	3930/1220H	Fil. Peo. Net	GI 1.5 MPEG
Ap1/138E	4100/1050V	ESPN	B-MAC
PAS2/169E	3836/1314H	ABS/CBN	GI 1.5 MPEG
PAS2/169E	3989/1161V	Fox/Prime	Sa1.5MPEG

DAILY UPDATES: Find out the latest changes in Asia-Pacific satellite activity, daily, on our Web site:  
<http://www.satfacts.kwikkopy.co.nz>

### August Alert

There are no new satellite launches until late August. With increased Ku-band activity in the offering, this might be a good time to locate a Ku-quality dish in the 2.4 - 3m size range which can be motor driven on a polar mount.

### Upcoming Satellite Launches

NSS-K to 95E - 30 HP Ku, (still) "late August"  
 Chinasat 8 to 115.5E- (date unknown) 32C, 16Ku  
 Telekom 1 to 108E - "late August", replace B2R

KoreaSat 3 to 116E -12-18 August, 16 Ku to replace Ks1  
 Express A1 to 80E - August 30, 12 C, 5 Ku  
 GE1-A to 108E - 28 HP Ku (Nov-Dec.)



# WITH THE OBSERVERS

## AT PRESS DEADLINE

Thai TV5 is reported operating within the Mediasat 12.336 bouquet (see p. 6) on programme channel 7 (VPID 1460, APID 1420, PCR 1460) by Bill Richards and others as this issue goes to the printer. Meanwhile, Humax IRD deployment has been delayed for TRT; daily updates on <http://www.satfacts.kiwickopy.co.nz>.

**ApStar 1/138E:** "Time to update your listings - those available here are Reuters HK (3742/1408Vt, SR 5.632, FEC 3/4), Viacom - including MTV (3860/1290Vt, SR 30.000, FEC 3/4), SDTV-Play 1 (4195/955Vt, SR 4.686, FEC 3/4) plus analogue 4160/990Hz CETV at P3 and ESPN B-MAC at 4100/1050Vt" (Nolan, Katherine, NT).

**ApStar 1A/134E:** Two digital signals here, available in northern Australia - Gansu TV 3769/1381Vt (SR 6.930, FEC 1/2) and Chongqing TV, SR 6.930, FEC 1/2. (Nolan, NT).

**AsiaSat 2/100.5E:** Saudi Channel 1 is now on 3661/1489Vt, SR 7.128, FEC 3/4. Audio feeds have been added at 7.02/7.56, 7.20, 7.74/7.92, 8.10/8.28 and 8.46 (Euro Sport) for RTPi on 3980/1170Vt. New Chinese radio stations - Henan Economic Radio (APID 81) on 3706/1444Hz, Fujian Economic Radio (APID 81) on 3720/1430Hz, Jiangu People's Radio (APID 256, right channel) on 3827/1323Vt, Jilin People's Radio (APID 1211, right channel) on 3875/1275Vt. "Missing audio on WorldNet (3764/1386Hz) is traced to personnel at Kuwaiti turnaround uplink station who have been negligent - USIA in Washington DC promises more diligent management of their services" (Burton, NZ).

**AsiaSat 3S/105.5E:** CETV has switched from 3760 to 3680/1470Hz. "Check PTV2 for new teletext service" - 4100/1050Vt (Hudson, NZ).

**Gorizont 30/LMI-API/130E:** "When NTV analogue on 3675/1475 shuts down at end of broadcast day, try entering this frequency with SR6.108, FEC 3/4 into digital IRD. The THT service which runs on 3725/1425L appears here in parallel (two channel) operation and is the strongest digital signal I have ever seen - plus it holds in far longer on this frequency (without moving dish to track) than on 3725" (Kosmalski, NZ).

**InSat 2E/83E:** Sun TV is replacement for Udaya TV, 3481/1669Vt. "Testing of the various Indian channels audio has been ongoing, try 5.5 (old frequency) and 6.6 to locate audios" (Leach, NSW).

**Intelsat 701/180E:** The "Ten Australia" bouquet on 3765/1385R (SR29.900, FEC 7/8) is now carrying the Trinity Broadcasting Network (TBN) feeds full time, FTA. "This bouquet was down by 3 dB for five days early in August, a telephone call to Intelsat Operations Control resulted in a prompt return to former levels - it pays to complain!" (Tony Drexel, SA). French Canal + Ku-band bouquet on Ku steerable beam 2 will be horizontal and somewhere in the

As of 31 July 1999,  
National Geographic Channel  
will terminate its transmission  
on PAS2. NGC transmissions  
have been migrated to AsiaSat3.

For further information contact  
+852 26217777.

NBC's National Geographic Channel was 50% purchased by Star TV Asia in 1998; and on July 28 this slide appeared advising all NGEOS service has been moved off of PAS-2 FTA to As3S and inside of the Star Asia bouquet (CA and not available to DTH except in limited areas).

frequency range of 10.950 - 11.700 (Holzt, New Caledonia relaying advisory from Intelsat - note contact on this is Abraham Chemuit at tel 1-202-944-7037, fax 1-202-944-8130, Email [abraham.chemuit@intelsat.int](mailto:abraham.chemuit@intelsat.int).) Programme package likely to include - but not confirmed - is Cine Cinema (Movies), LCI (News), Eurosport, XXL (real hard core stuff for adults), MCM, Fox Kids (in French of course), Planete (a Discovery like service). Packages likely to be priced - also not confirmed - as RFO1, RFO2, RFOSAT FTA, Canal + Caledonie pay-TV channel plus 3 FTA channels - around US\$70, and up - for FTA plus all but XXL with XXL offered as an optional fourth tier (source, Canal +).

**Intelsat 702/177E:** "Thai 5 bouquet is still running FTA here, strange because there is no real reason for it to be here" (Leach, NSW).

**JcSAT3/128E:** TBN testing on 3990/1160V, SR5.026, FEC 3/4; is PowerVu and levels are up and down, service is not always FTA (Kosmalski, NZ). "This is a test, we have made no decision yet which satellite will be used to service Asia" (Ben Miller, TBN, USA). "Solid signal here with VPID 1160, APID 1120 - only problem - it is PowerVu and NTSC - yuk!"

**WITH THE OBSERVERS:** Reports of new programmers, changes in established programming sources are encouraged from readers throughout the Pacific and Asian regions. Information shared here is an important tool in our ever expanding satellite TV universe. Photos of yourself, your equipment or off-air photos taken from your TV screen are welcomed. TV screen photos: If PAL or SECAM, set camera to f3.5-f5 at 1/15th second with ASA 100 film; for NTSC, change shutter speed to 1/30th. Use no flash, set camera on tripod or hold steady. Alternately submit any VHS speed, format reception directly to SatFACTS and we will photograph for you. Deadline for September 15th issue: September 3 by mail (use form appearing page 34), or 5PM NZT September 6th if by fax to 64-9-406-1083 or Email to [Skyking@clear.net.nz](mailto:Skyking@clear.net.nz).

(Zapara, WA). ""Our Hyundai locks it 30% of time on 3.7m KTI, but our D9223 locks it 80% of time" (Hudson, Timaru, NZ). "Analogue test card seen here on 4085/1065Vt, P4, audio 6.8 and video NTSC July 22nd - so it is not totally off the air" (Leach, NSW).

**LMI-AP2/142.5E:** "Requires dish realignment about every 90 minutes; audio on Pacific Satellite promo started on 6.03, moved to 7.20" (D. Leach, 3.7m, NSW). "Pacific Sat promo French text crawl on bottom of screen says 'The best French bouquet of the Pacific will soon start on LMI-AP2 in digital' " (Kosmalski, NZ). "Is there also a digital service testing at 3785/1365? I get indication of one here" (Alek Zapara, WA). "P5 (peak) reception here with 3m KTI" (**Bannister**, WA).

**Optus B1/160E:** "ABC for NT, plus 3 radio services, now running on 12.256Vt, SR 5.026, FEC 3/4 - hope it lasts!" (Colquhoun, NZ). "Is Sydney minus 30 minutes feed" (Sharp, NSW).

**Optus B3/156E:** "(We have chosen PowerVu) for the Mediasat (TRT) bouquet due to their true DVB compliance" (**Paul Mullen**, Mediasat). "Unless there is a cheap fix for the UEC IRDs to receive TRT, I believe there will be plenty of second hand 642 and 660 IRDs for sale!" (**Jack Smith**, Victoria). "Some TRT information from Turkish Consulate at 03-9696-6066" (**Pietro**, Victoria). HBN appears now on 12.480Vt, FTA analogue (McLeod, NZ). "Are these data services at 12.267 and 12.280Vt - SR 4.000, FEC 3/4?" (McLeod, NZ). "Austar testing of new software that changes on-screen graphics was a disaster here - now I have to reset the decoder daily, it won't do Aurora and when I try to go back to factory default settings it hangs up and just gives me the channel listings. This is not an improvement!" (**Johnson**,

WA). If Weather Channel will not load on 12.438Hz, try VPID 520, APID 658, PCR 520. Fox News is August 1 starter on 12.438Hz with VPID 519, APID 657, PCR 519. "The best Aurora signal here is at least 2 dB lower in level than Austar/Foxtel carriers - 12.407Vt with only 0.5 dB headroom before tiling. 12.532 is at threshold and sputters, 12.720 is watchable only for a few peak signal hours each day, while 12.595 has never locked here - on 3.6m Orbitron micromesh and 0.6 dB Gardiner LNB" (Holzt, New Caledonia).

**Palapa C2/113E:** Still FTA as we go to press, C-Net/Space TV package at 4000/1150Hz (SR26.660, FEC 3/4) has added BBC World to bouquet; up to 12 TV programme channels, crawl announcement says they will encrypt soon (SR was 21.095, FEC 5/6).

**PAS2/169E:** CNBC test card is holding down previous two National Geographic program channels on NBC Bouquet 4093/1057Vt. Someone testing on 3822/1328Hz, SR 10.000, FEC 3/4, no identification but exceptionally strong here (McLeod, NZ). "Boot loader software download for D9223 carried by ESPN bouquet (3860/1290Vt, SR 26.470, FEC 7/8) - go to channel 12 and in 15-20 minutes time, latest SA software will load. At end message comes up on screen saying download is complete. After doing this - with sweaty palms - found the IRD would load anything, C or Ku, SCPC or MCPC, PAL or NTSC. Amazing" (**Hendriks**, Tasmania). "This service actually works surprisingly well, and typically it takes me 12 minutes to download the latest software" (**Philips**, Australia). Jet-TV has - once again - left 3963/1187Vt. Discovery Channel is quoting price of US\$650 plus freight for SA D9234 shipped directly from Canada, model 9234BSR is even less (advisory from Discovery).

# JACOBSON'S

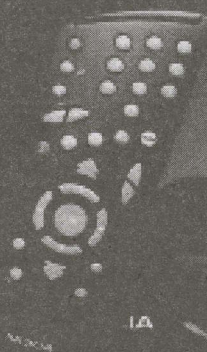

THE NEW GENERATION OF DIGITAL  
SAT. RECEIVER IS HERE!  
НОВОЕ ПОКОЛЕНИЕ ЦИФРОВЫХ СПУТНИКОВЫХ  
РЕСИВЕРОВ!  
9800S

UNIQUE HIGHLY INTEGRATED ONE-CHIP SOLUTION WITH A TEN TIMES BETTER  
PROCESS CAPACITY....

MAKE SURE YOU BUY THE BEST! ASK US WHERE YOU CAN GET IT!  
УНИКАЛЬНОЕ ВЫСОКОИНТЕГРИРОВАННОЕ РЕШЕНИЕ С ДЕСЯТИКРАТНЫМ  
УВЕЛИЧЕНИЕМ СКОРОСТИ ОБРАБОТКИ ИНФОРМАЦИИ....  
БУДЬТЕ УВЕРЕНЫ - ВЫ ПОКУПАЕТЕ ЛУЧШЕЕ!  
СПРОСИТЕ НАС, ГДЕ ВЫ МОЖЕТЕ ЭТО ПРИОБРЕСТИ!

**NOKIA**  
Receiving Equipment  
Direct to home

**EMITOR AD**  
Test equipment  
and accessories

**425**  
Digital cable-TV head  
equipment  
and Microwave link

**ELCON**  
Multi switches

**SMW**  
SWEDISH MICROWAVE  
Digital professional link

**Channel Master**  
Satellite Antennas

JACOBSON'S, авторизованный дистрибьютор в следующих странах: Россия, Беларусь, Украина, Молдова, Грузия, Армения, Азербайджан, Казахстан, Туркмения, Киргизия, Таджикистан, Эстония, Латвия и Литва.

Nedradal S • 59197 Motala • SWEDEN • Phone: +46 141 220 331 • Fax: +46 141 220 111 • Website: www.jacobsons-t.s • E-mail: info@jacobsons-t.se  
+46 141 220 080 • Mob: +46 706 80 06 24 • Ask us for catalogue!

### Tuning In KIBC on AsiaSat 2

KIBC operates on 3940/1210 vertical, AsiaSat 2 with a SR of 26.655 and FEC of 2/3. However, there is a problem. KIBC (which is a mostly English language Filipino ex-pat service) is combined with an Internet service provider's data stream (ZakNet) and as such must accept the parameters established by the ISP. Early in June, ZakNet modified their data stream and suddenly IRDs that would previously load the service could no longer do so. The answer is that your IRD will load the service provided you have the IRD-ability to enter the KIBC "PID/PCR" numbers. Nokia IRDs will, the current Av-Comm IRDs will, Sat Cruiser models will. Hyundai will not, SK888 will not and so on.

You may not be familiar with PID/PCR loading. If your IRD will accept these "direct load" numbers, your instruction manual will guide you. Some IRDs, such as the Sky Vision Australia Sat Cruiser line are supported with a Web site that gives step by step instruction ([www.bigfoot.com/~skyvision/support.html](http://www.bigfoot.com/~skyvision/support.html)). Our own SatFACTS site ([www.satfacts.kwikkopy.co.nz](http://www.satfacts.kwikkopy.co.nz)) also has extensive instruction. First, enter the frequency/SR/FEC parameters. If your IRD loads but refuses to show the signal (treating it as a CA service), then while on the memory channel which loaded KIBC enter your PID/PCR sub-menu routine and enter Video PID 35, Audio PID 36, PCR 35. This should instantly play KIBC and from this point onward KIBC will play whenever you select its IRD memory channel on your IRD. *And happy viewing of SPACE Pacific Report!*

**PAS8/166E:** "With a 3.6m Orbitron micromesh dish, Gardiner 0.6 dB LNB, I locate the following Ku-band signals here: 12.285 (Phoenix 111 loads and locks but does not play - 10 dB C/NR, Pacific Time Entertainment), 12.331 (ABC Interchange, 7.5 dB C/NR), 12.366 (2 dB C/NR, Pacific Time Entertainment), 12.466 (3 dB C/NR, unknown), 12.526 (TARBS, no lock with 7 dB C/NR), 12.640 (unknown data, 7 dB C/NR), 12.687 (unknown data, 10 dB C/NR) and 12.724 (unknown data, 10 dB C/NR)" (Steffen Holz, New Caledonia). 'Night Moves' now sharing with TARBS promo (VPID 512, APID 640) after 22.45 Sydney. "TARBS package and ABC Interchange both solid here on 65cm dish" (Leach, NSW). "ABC Interchange (12.332Hz) on 3.7m Orbitron 42% on Phoenix 333, but drops out after 5PM daily" (Hudson, Timaru, NZ).

**ST1/88E:** Cosa TV 3441/1709Hz is FTA (VPID33, APID 34). Open TV, test card in two channel MPEG-2 FTA 3547/1603Vt, SR 5.800, FEC 3/4.

**Telekom/108E:** Launch delayed because of rocket problem to August 12/13 within 22.52 - 00.42 window. "Footprint map does not look promising for Australia/Pacific" (Tony Drexel, SA).

**Thaicom 3/78E:** TRT is being fed through to Australia on 3525/1625Hz, SR 5.698, FEC 3/4 with TRT-FM and others tagging along.

### AUSTRALIAN?

Av-Comm Pty Ltd. has the "best" service for subscriptions to SatFACTS Monthly and Coop's Technology Digest!

Tel 02-9949-7417 or

Email [cgarry@avcomm.com.au](mailto:cgarry@avcomm.com.au)

Proudly a sponsor of SPACE Pacific Report!

# ADI MediaMate

## Digital Satellite Receiver

**SPECIAL INTRODUCTORY PRICE** INCLUDES TAX

**ONLY \$695**

CALL FOR EXPORT \$\$\$

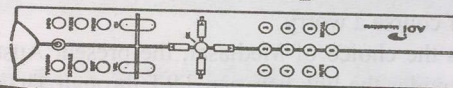

**DVB**  
Digital Video Broadcasting

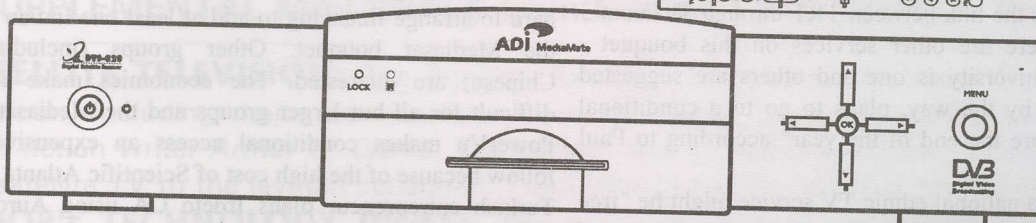

- Low Threshold Performance
- Easy to use Graphic Interface
- 2 - 32 Msymbols (FTA Power View)
- NTSC & PAL Outputs
- 22Khz / DiSeQ / 12VDC Aux
- Teletext Output in Video
- 90 - 264 VAC 47 - 63 Hz Power supply
- 27 / 36 Mhz Tuner
- PID Menu
- RS232 Computer Control & Software Download

Also Available 1.8m & 2.4m Solid Steel Dishes & MTI Dual Pol C Band LNBFs  
**Pacific Digital Systems Pty Ltd Ph. 61 2 8765 0270 Fax. 61 2 8765 0275**

**EXCLUSIVE AUSTRALIAN, NEW ZEALAND, PACIFIC ISLANDS DISTRIBUTOR**

# AT

## Sign-off

### Be careful what you wish for ...

Rumours that a Turkish TV channel would be made available to Australian viewers have been creeping around the edges of the industry since March. Prior to that, we had an "official" statement from the Board of Directors managing the affairs of the European Bouquet explaining that if MCM Music could work out the technical details, it would leave the bouquet and be replaced with a Turkish channel. We have no reason to believe that plan is dead, or that TRT Turkey was in fact the Turkish service which was negotiating this with MCM.

Turkey is a country of nearly 64 million, placing it in the same league as the UK, Germany and France. TRT is a major supplier of television, but hardly the only one. Turksat 1C, a satellite, operates from 42E and provides a variety of services for Turkey and neighbouring countries.

The usually spot-on Australian bureau of statistics is not certain how many Turkish immigrant families reside in Australia - the Turkish Consulate in Melbourne suggests 40,000. New Zealand statistics give no clue how many Turkish immigrants are in the country. Turkey and a group called the "Kurds" share an almost common language and you may recall that Kurds live (amongst other places) in northern Iran bordering on Turkey.

In a country of 18.5 million, it is challenging to accept that a group as small as 40,000 households (132,000 people give or take a few) could create total chaos in our industry. Yet that is precisely what happened when TRT appeared on satellite.

As we report on p. 6 here, the Scientific Atlanta PowerVu format TRT signal is free to air and we have the assurances of both the Turkish Consulate and bouquet provider Mediasat it will stay that way "for at least two years." That there is a time line attached to how long they might stay FTA is itself curious. That it could revert to conditional access PowerVu after two-years is of course a worry.

PowerVu is the choice of Mediasat, the present Australian carrier that provides the link between TRT through Thaicom 3 and Optus B3. There are other services on this bouquet - Maharishi Open University is one and others are suggested very soon. 'MOU', by the way, plans to go to a conditional access format "before the end of the year" according to Paul Mullen at Mediasat.

The concept that a national ethnic TV service might be "free to air" is novel inside of Australia although an accepted way of doing business elsewhere. With C&W Optus cable charging as much as \$19.95 for a single ethnic channel, and Foxtel offering ethnic cable or satellite services at \$9.95 per month, groups such as the Greeks have good reason to be upset. "If the Turks can supply FTA service to their ex-pats, why should our country charge us for service?" Of course the fees being paid for Greek TV and others are largely going into the pocket of the cable or satellite supplier, not the Greek or other point of origin supplier. What the Turks appear to have done is to



Maharishi Open University is on programme channel 1 of the new Mediasat Optus B3 Vt bouquet; 12.336

arrange for domestic satellite distribution inside of Australia at absolutely no direct fee to the viewers. There is a hint as to why this might have happened.

More than one business group is talking about bringing into Australia one or more movie and other special event channels. These additional channels would be CA (conditional access). As we report starting on p. 6 here, a Turkish businessman importing Korean built Humax IRDs believes he can marry PowerVu FTA and Irdeto conditional access with a single IRD - and using TRT in a free to air format as a magnet, attract sufficient Turkish viewers to make possible an optional CA service. Putting up free to air service as an enticement to viewers to use their own money to purchase receiving equipment is not a new technique. Rupert Murdoch employed a similar approach when launching the original four-channel analogue BSKyB service nearly a decade ago. In this case, if an entrepreneur can somehow talk the Turkish Government into paying the cost of a digital programme channel slot for two initial years, at the end of this period there may well be sufficient potential users out there to make a conditional access channel or channels viable. What nobody knows for sure is whether the chosen Humax receiver will do all of this.

Mullen's Mediasat footprint creates some interesting business opportunities; a New Zealand group, anxious to bring Indian TV programming with small dish size here, is working hard to arrange financing to add at least one Indian channel to the Mediasat bouquet. Other groups (including Thai's, Chinese) are interested. The economics make free to air difficult for all but larger groups and the Mediasat choice of PowerVu makes conditional access an expensive route to follow because of the high cost of Scientific Atlanta IRDs. The Turkish entrepreneur plans Irdeto CA using Aurora for his pay-TV channels. *It could be a difficult marriage.*

What this tells all of us is that there are very few roadblocks to progress which cannot be worked around. Some have expressed surprise that PowerVu was "allowed" on Optus, possibly because competitor PanAmSat will allow only PowerVu except with special dispensation. In fact, while Optus may not be a fan of Scientific Atlanta and PowerVu, there is no logical reason to keep a good client such as Mediasat from selecting any MPEG format they wish. Mediasat has a second Optus transponder on order - hopes to activate it by the end of the year. All of which suggests that dish terminal growth will not be slowing down anytime soon.

## THE 1999 SATELLITE EXPLOSION IN THE PACIFIC/ASIA!

**Telekom 1 to 108E? French Porno Flicks at 142.5E? The explosion continues!  
Stay tuned with SatFACTS!**

- ENTER my 12 MONTH subscription to SatFACTS starting with September 15th issue (rates below)  
 ENTER my 36 MONTH subscription to SatFACTS starting with September 15th issue (rates below)

NAME \_\_\_\_\_  
Company (if applicable) \_\_\_\_\_  
Mailing address \_\_\_\_\_  
Town/city \_\_\_\_\_ Country \_\_\_\_\_

**Amount to send:** 1 year - NZ\$60 (inside New Zealand) / A\$90 (inside Australia) / US\$60 (outside of NZ and Australia) or 3 years - NZ\$140 / A\$210 / US\$150 if by cheque. **VISA or Mastercard?** See form below and return with order. Return to: **SatFACTS, PO Box 330, Mangonui, Far North, New Zealand** or if by VISA or Mastercard fax to 64-9-406-1083

**IF YOU ARE IN AUSTRALIA - See AV-COMM Pty Ltd Advert p. 31!**

### USE THIS FORM ONLY WHEN CHARGING ON VISA/MASTERCARD

Please charge my **VISA/Mastercard** as follows:

- ONE Year of SatFACTS MONTHLY (NZ\$60, A\$90, US\$60)  
 THREE Years of SatFACTS MONTHLY (NZ\$140, A\$210, US\$150)  
 SATELLITE TELEVISION: The Booklet (NZ\$10, A\$12, US\$10)  
 One Year of COOP'S TECHNOLOGY DIGEST (NZ\$125, A\$125, US\$125)  
Indicate charge card type:  VISA  Mastercard

Name (as it appears on **VISA / Mastercard**) \_\_\_\_\_  
**VISA/Mastercard** Number \_\_\_\_\_  
**VISA/Mastercard** expiration date \_\_\_\_\_

**Instructions:** If ordering by mail, return this complete (3-part) card or a copy of same (to **SatFACTS, PO Box 330, Mangonui, Far North, New Zealand**); if order by FAX, send full card as a single sheet to **64-9-406-1083**

**ALL COPIES OF SatFACTS Monthly are sent via Air Parcel Post world-wide!**

### SUPPLEMENTAL MATERIALS from SatFACTS MONTHLY: Order Form

- SATELLITE TELEVISION:** The Booklet. Excellent introduction to home dish ownership for the layman, including major contributions from the father of geostationary satellites - famed science fiction writer *Arthur C. Clarke*. The perfect tool to help the satellite system seller explain home satellite TV to the layman consumer. From *SPACE Pacific*. NZ\$10 / A\$12 / US\$10, airmail.
- COOP'S TECHNOLOGY DIGEST.** For the really serious enthusiast, investor, business person in satellite television and allied leading edge technologies. Ten issues each year, jam-packed with information you will not find anyplace else. "Coop" routinely culls more than 60 publications world-wide, terribly expensive newsletters, Internet and his hundreds of private contacts to keep you right at the leading edge of technology on the **REAL** changes underway in telecommunications. Conveniently issued near the **first of the month**, creating an excellent time-line-filler between the mid-month issues of SatFACTS. Now in the **6th year**, airmail world-wide. Normally NZ/A/US\$250 per year - for SatFACTS subscribers special 50% discounted price of NZ/A/US\$125.

## OBSERVER REPORTING FORM - Due September 4, 1999

- NEW programming sources seen since August 1st: \_\_\_\_\_
- Changes (signal level, transponder, programming content) in pre-existing programming sources since August 1st: \_\_\_\_\_
- OTHER (including changes in your receiving system): \_\_\_\_\_

NOTE: Please use P1 - P5 code when describing signal levels and receiver IF/RF settings.

Your Name \_\_\_\_\_

Town/City \_\_\_\_\_

Make/size dish \_\_\_\_\_ LNB \_\_\_\_\_ Receiver \_\_\_\_\_

Your email address \_\_\_\_\_ if you have one!

RETURN: SatFACTS, PO Box 330, Mangonui, Far North, NZ, fax 64-9-406-1083, Email Skyking@clear.net.nz

### Do YOU Know Someone Who Would Benefit From SatFACTS???

**SEND US THEIR NAME AND MAILING ADDRESS -  
and we will send them a FREE sample copy!**

YES - send a FREE sample copy of SatFACTS to ...

NAME \_\_\_\_\_

Company (if applicable) \_\_\_\_\_

Mailing address \_\_\_\_\_

Town/city \_\_\_\_\_ postal code \_\_\_\_\_ Country \_\_\_\_\_

Return to: SatFACTS, PO Box 330, Mangonui, Far North, New Zealand or fax to 64-9-406-1083

**IS it just a COINCIDENCE  
Members of SPACE have more work  
than they can handle?**



YES - send me information about how joining SPACE Pacific can lead me to more, profitable work!

NAME \_\_\_\_\_

Company affiliation (if any) \_\_\_\_\_

Mailing address \_\_\_\_\_

Town/city \_\_\_\_\_ postal code \_\_\_\_\_ Country \_\_\_\_\_

# Sky Vision Australia

*A Proudly Australian owned and operated company*



## SAT CRUISER DSR-101 MPEG 2 DVB / POWER Vu RECEIVER

***Latest Model – New Features  
Best value receiver in Australia !***

*Trade Price - quoted to established dealers*

- √ The ideal consumer orientated receiver with features that will please the enthusiast !
- √ Pre-programmed with all active TP's from Asiasat 2, Palapa, PAS 2 ,PAS 8 and more
- √ 10 spare user defined satellite positions for future satellite launches
- √ Simplified manual TP entry – TP Frequency is the only required parameter !
- √ Auto Symbol rate – Auto FEC – Auto PID's – Auto Polarity (LNBF)
- √ Satellite naming/editing – Channel naming/editing
- √ Alternate audio channels accessible from remote control
- √ On-board NTSC – PAL 50 Hz convertor – compatible with any PAL TV
- √ On-board Digital TELETEXT decoder – no need for Text capable TV
- √ 5 language menu - English (default) Spanish / Italian / French / German
- √ Consumer friendly graphical interface – Easy to install !
- √ UHF Ch 21-69 Software controlled RF Modulator – Low spurious emissions
- √ Low threshold dual bandwidth tuner – Dual SAW filter IF stage
- √ C Tick certified to comply with Australian Communications Authority standards
- √ Ultra reliable SMPS module – not a single reported failure to date !
- √ Full colour photographs and screen shots available from our web site
- √ 12 month replacement warranty – With an optional extended warranty plan
- √ Feel free to call one of our friendly staff for more information !

DSR-201P Analog/Digital/Positioner receiver ..*Trade Price - quoted to established dealers*

Export – Wholesale – Trade sales

Web Site: <http://www.bigfoot.com/~skyvision>  
E-mail: [skyvision@bigfoot.com](mailto:skyvision@bigfoot.com)

Tel: 02 62925850

Fax: 02 62925890

# ANTEL

## Precision Spun Aluminium Dishes

### Antel 2.3

Single piece spun aluminium dish.

Total Diameter	2.4m
Reflector Diameter	2.3m
Pole size	102mm
F/D ratio:	0.4
Focal Distance	930mm
Gain: (>60% efficiency)	
4GHz	37.7dBi
12GHz	47.2dBi
Beamwidth 12GHz	0.53°
Maximum Wind Speed	
Operational	120kph
Survival	160kph

Finish:

Dish	Epoxy-Polyester Powder Coated
Mount	zinc plated

Weight

Polar mount	44kg
Reflector	33kg
Two mount options:	Fixed & Polar



### Antel 1.8

Single piece spun aluminium dish

Total Diameter	1.9m
Reflector Diameter	1.8m
Pole size	89mm
F/D ratio:	0.41
Focal Distance	740mm
Gain: (>60% efficiency)	
12GHz	45.5dBi
Beamwidth 12GHz	1°
Maximum Wind Speed	
Operational	140kph

Finish:

Dish	Epoxy-Polyester Powder Coated
------	-------------------------------

Two mount options:

<b>Luxury Mount (fixed)</b>
Spun aluminium ring, stainless steel elevation rod, fully galvanised pole cap.
<b>Standard Mount (fixed)</b>
Zinc plated ring, elevation rod and pole cap.

These quality products distributed by:



Phone: +61 8 9306 3738 Fax: +61 8 9306 3737  
sales@sciteq.com.au <http://www.sciteq.com.au>