

Bob Cooper's

JUNE 15 1999

# SatFACTS

MONTHLY



Reporting on "The World" of satellite television in the Pacific and Asia

## IN THIS ISSUE

**COOL & COLD  
LNBS -  
the difference**

**As3S Settles In  
for the long haul  
and making money**

**PAS-8 Ku;  
Trick Cards;  
Imparja Ambitions**

- ✓ Latest Programmer News
- ✓ Latest Hardware News
- ✓ Latest SPACE Pacific Reports
- ✓ Cable TV Connection

**Vol. 5 ♦ No. 58  
Price Per Copy:  
NZ\$9/A\$10/US\$7**

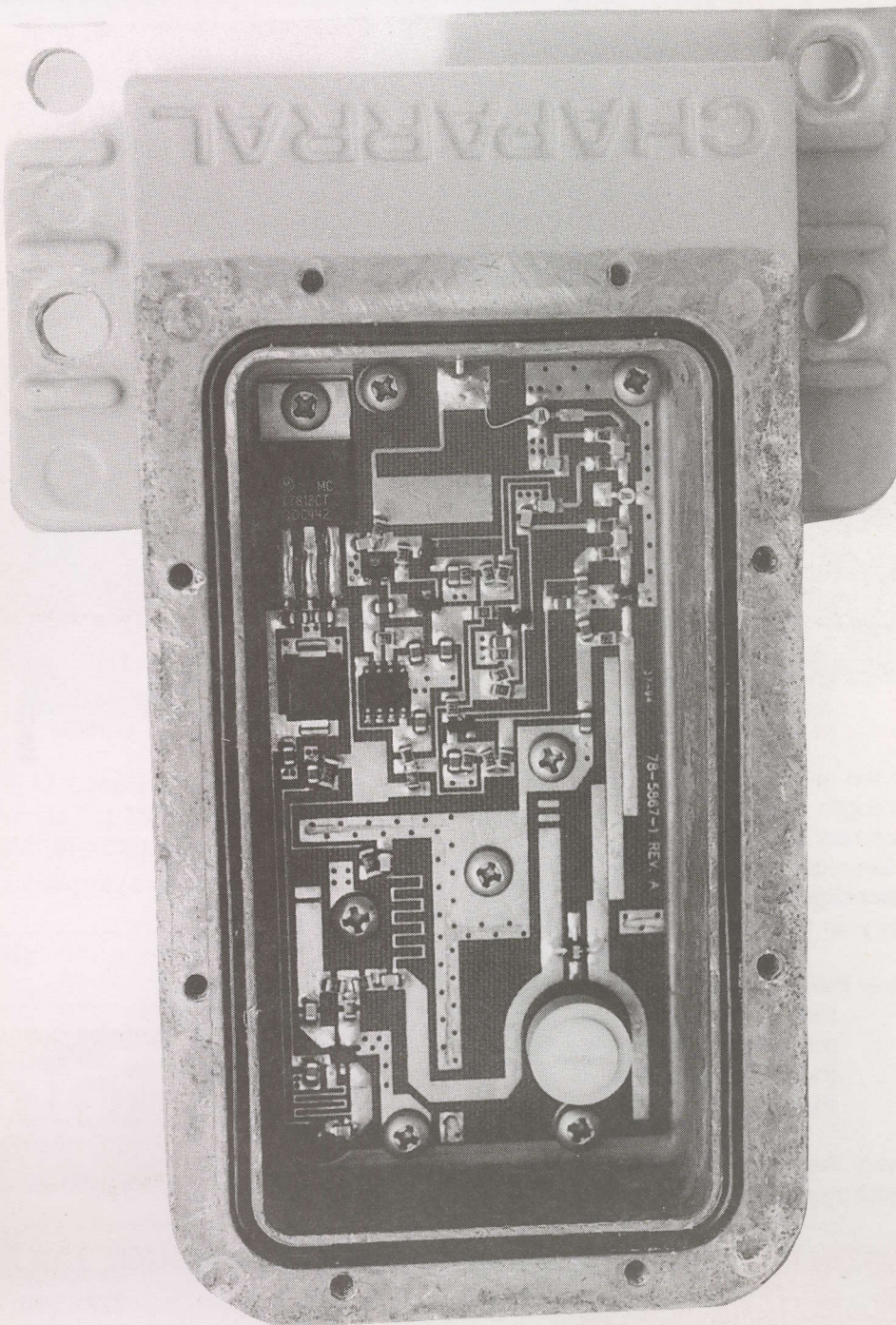

# Paraclipse<sup>®</sup>

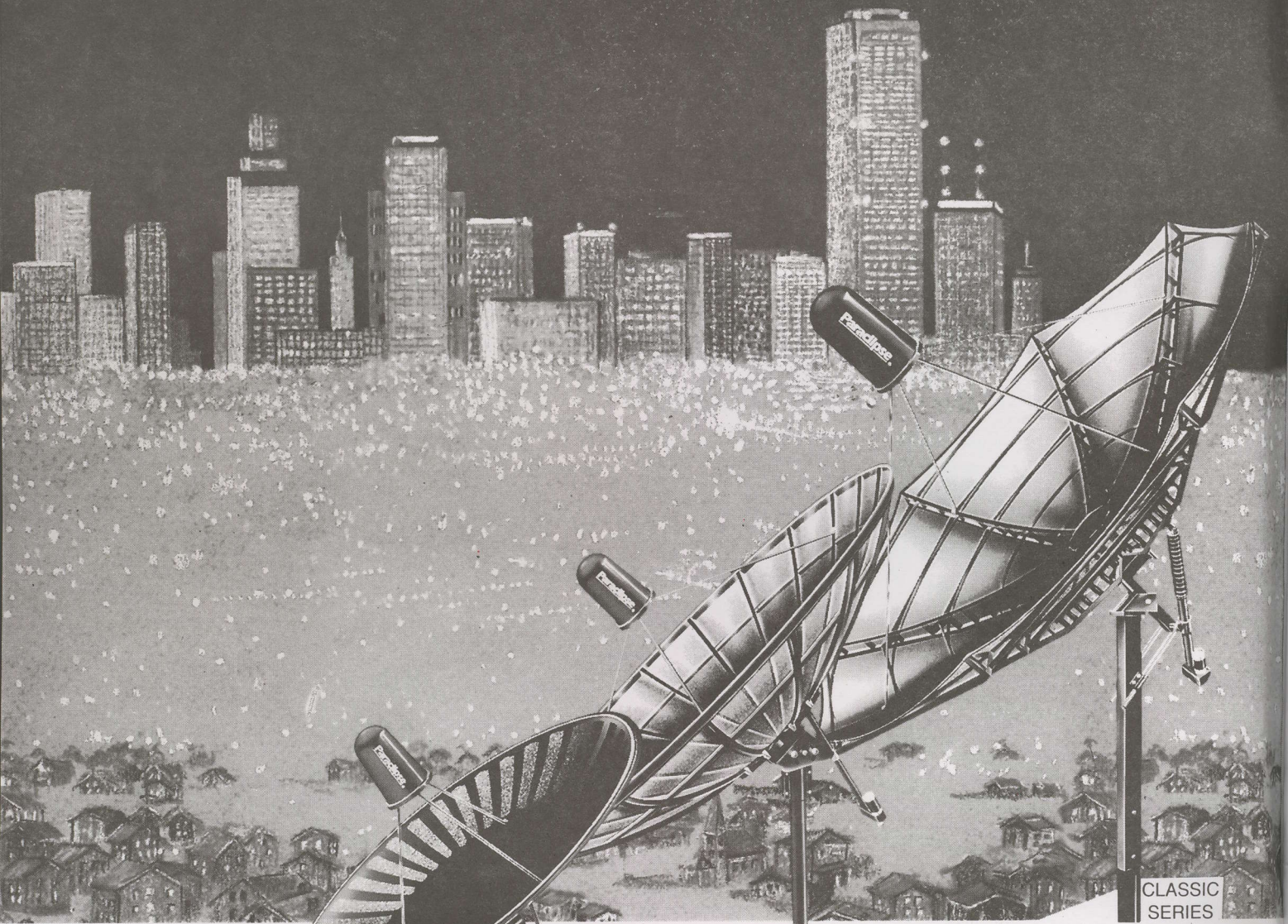
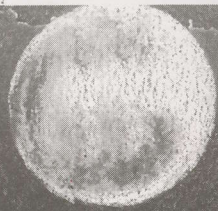

CLASSIC  
SERIES

ECLIPSE  
SERIES

HYDRO  
SERIES

When quality, strength, and accuracy are your main requirements, **Paraclipse** antennas are your first choice.

Only **Paraclipse** offers such variety; four distinctly different series: the Truss-Ribbed Classic, the Courier Deliverable Eclipse, the Stretch Formed Hydro, the Commercial Patriot.

Every **Paraclipse** model sets the industry standard in its class, worldwide.

Distributed in Australia & the Pacific by

**SATECH Satellite  
Communication**

**Technology Pty. Ltd.**

18/477 Warrigal Rd, Moorabbin  
East, Victoria, Australia 3189  
tel 61-3-9553-3399  
fax 61-3-9553-3393

**Paraclipse<sup>®</sup>**  
HIGH PERFORMANCE ANTENNAS

★ **MADE IN  
AMERICA**

Paraclipse Inc.  
2271 29th Avenue East, Columbus, Nebraska USA 68601  
Telephone: (402) 563-3625 Fax: (402) 564-2109

# SPACE PACIFIC REFERENCE MATERIALS

to help you do a better job, profitably

*Some are in limited quantity (marked LtdQty); most have special SPACE member discounts*

Gibson  
Navigator

**The Gibson Satellite Navigator Manual.** Geo-stationary (Clarke Orbit belt) satellites "fly" along a very precise highway. Celestial navigator Steve Gibson makes it all very simple to understand, explains how polar mounts (and others) work, gives you step by step instructions to make your dish systems "track" the orbit belt. This manual established the basics for several decades of satellite enthusiasts - everyone who knows his "satellite tracking" starts off with "Gibson." It is the final word on dish tracking systems. Reprint of original. (LtdQty) at half of cover marked price.

Coop's  
Basic  
Manual

**Coop's Basic Manual on Fine Tuning Private Satellite Terminals.** Solar outage, connectors, receiver peaking, tracking unusual orbit birds (including Molniya), measuring signal to noise ratios, footprint maps and what they mean, simple ways to adjust dish elevation and azimuth, installing and peaking the feed antenna, coaxial cable interfacing from dish to receiver(s), polarisation

**SORRY - Sold Out for now!**

Coop's  
Operations  
Manual

**Coop's Satellite Operations Manual.** Geometry of a satellite dish (dry stuff but important to get maximum gain from your system), peaking the LNB for maximum performance (location is critical), azimuth and elevation sweep for satellites, C/N and S/N numbers - what they mean, the satellite design and the footprints it creates, rebroadcasting through the air to "friends" and neighbours, tuning in sub-carrier signals (with construction project), narrow band audio and data interception, circular polarised feeds you can build, sound in synes decoder, and much-much more. This is one GREAT manual! Reprint of original (LtdQty), 1/2 original price.

Nelson  
Parabolic  
Manual

**The Nelson Parabolic TVRO Manual.** It take a very special person to want to build his or her own dish. Tens of thousands have done so, virtually all of them have done so by using this manual as their step-by-step manual. Nelson Ethier was one of a kind (rest his soul) and here he describes everything important in logical step by step format to build a professional quality dish up to 12 feet (3.7m) in diameter. Even if you never intend to build a dish, this manual will become a constant companion as you evaluate dish antennas others have built. This is the "bible" of antenna people (reprint of original, LtdQty); half original price.

**AS LOW AS THESE PRICES ARE - THERE ARE SPECIAL PACKAGE PRICES ON BACKSIDE!**

World  
Sat TV 92

**The World of Satellite TV (1992)/ Asia, Middle East, Pacific Rim.** (Mark Long) Yes, it is somewhat out of date but the first 12 chapters (of 14) are basic and basics don't change. Nobody does it better than Long, some people we know collect one-each of every one of his books believing they will soon become collector items. We have a tiny number (LtdQty) and when these are gone at \$10, that is it for this edition.

World  
Sat TV 96

**The World of Satellite TV (1995)/ Asia, Middle East.** (Mark Long) Updated version of above, 13 very useful chapters + two that are slightly dated (including the then new world of digital). Hey - it is Mark Long and his writing is clear and concise and accurate. Bargain priced at \$15. (QtyLtd)

TB 9404  
DTH  
Systems

**Direct to Home: Home Satellite System Installation Techniques.** Without question, the very best quick tutorial on what a home dish system is, how it works, where the problems develop. If you are new to the field or need to teach someone the ground rule basics, this is the right one. (Very) slight New Zealand bias, not enough to damage its teaching abilities no matter where you are. Plain language, in the best style of Coop. \$10 but quantity very limited - one to a customer.

TV 9405  
SMATV

**Satellite to Room - Commercial Satellite Dish Systems / SMATV.** Originally prepared for international satellite conference in Thailand, this is the "best of" companion to 9404 (above). If you are doing or plan to do motel, hotel, condo distribution systems fed by satellite, and need to know what you will be facing - start here. \$10, quantity very limited - one to a customer.

**SPACE Pacific Order Form (also see SPECIAL PACKAGES on reverse side)**

Please send the following:

- Gibson Navigator/\$15;  Coop's Operations/\$15;  Nelson Antenna/\$15;  
 World Sat TV(1992)/\$10;  World Sat TV(1995)/\$15;  Home DTH/\$10;  SMATV/ \$10.

Total of order: \$ \_\_\_\_\_. If CURRENT SPACE Member, multiply by 0.7 for discount total: \$ \_\_\_\_\_

I wish to pay this by  cheque (enclosed)  VISA card  Mastercard

Card number \_\_\_\_\_ expires \_\_\_\_/\_\_\_\_

Ship to (name as appears on credit card): \_\_\_\_\_

Company \_\_\_\_\_

Mailing address \_\_\_\_\_

Town/city \_\_\_\_\_

your signature \_\_\_\_\_

Return to SPACE Pacific, PO Box 30, Mangonui, Far North, New Zealand or fax 64-9-406-1083

**THREE NEW REFERENCE SOURCES - See page 34 of this issue!**

**Terrestrial TV Antenna Handbooks**



*Each of these editions researched, created by "Coop" to help you solve tough aerial problems*

**TB  
9301**

**Tech Bulletin 9301.** *Co-Channel & Antenna Phasing:* How to turn a simple antenna (one Yagi or broadband antenna) into a complex array with the ability to separate stations on the same channel ("co-channel interference"). Totally hands on, very practical, detailed how-to instruction covering VHF and UHF theory and practice. Go from Novice to advanced aerial installer right here! (LtdQty)

**TB  
9302**

**Tech Bulletin 9302.** *Weak Signal Reception Techniques.* If one cut-to-channel (Yagi) antenna won't do the job, will 2, or 4, or 8? How about 16? Stacking antennas, mating with hand selected masthead amplifiers is an art. This explains in hands-on practical language and drawings exactly how to do it - building terrestrial antennas that will work to distances of 300+km!. (LtdQty)

**TB  
9303**

**Tech Bulletin 9303.** *UHF - The Frontier.* Using parabolic style antennas and chicken wire mesh, it is possible to build 20-40 foot SUPER antennas for UHF-TV that will capture high quality pictures over distances of 300+km. Moreover, you can build on-channel relays using the techniques described here to "Squirt" signals through the air from a hilltop to a valley below - all quite legal, and very economical. The "tricks" here have been well hidden from general view previously - this is exciting, state-of-the-art stuff! (LtdQty)

**TB  
9304**

**Tech Bulletin 9304:** *Beating Noise & Combining Cross-Pole Signals.* When TV (and FM radio) signals are weak, man-made noise from appliances, power lines can kill reception. Here is the complete step by step story on identifying, locating and curing noise generation devices that inhibit fringe area reception. BONUS - if you have vertical and horizontal polarised signals at the same location, it is possible to "combine" them into a single downline to the TV set! (LtdQty)

**TB  
9305**

**Tech Bulletin 9305:** *Cable Television Fact and Fiction.* The story of how a cable TV system is designed, built, operated. The perfect "So this is how it works!" report. Who knows, you may get so excited by the prospects of becoming a cable TV operator, you will rush out and mortgage your house to build your own after reading this! (LtdQty)

**TB  
9403(t)**

**Tech Bulletin 9403(t):** *VHF/UHF Receiving Antenna Design.* This one started a "war" because it explains how to build your own deep-deep fringe "Logi" TV & FM antennas with three and four times

**SORRY - Sold out for now!**

the gain of the

**BRAND NEW - NOW shipping for those who can't wait! "RAW" SPACE Pacific Video!**

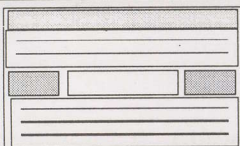

Shot at SPRSCS '99. The complete video "shoots" from the March Satellite + Cable Show, unedited, just as it was shot. Four hours on VHS T240 (SP) tape, direct from digital masters. "Feeds & LNBS" (41+ minutes); "What is the Market" (31+ m.); "What's Wrong With These Satellite Antennas?" (38+ m.); "Hard Drives Replacing VHS Tape?" (11+ m.); "With These Parts ..." (24+ m.); "Robin Colquhoun and Dr Overflow" (51+++ minutes).. Can't wait for the TV Show? Love out-takes? This is for you. Note to SPACE Members - NO discount on this one only!

**SPECIAL DISCOUNT BONUS PACKAGES with FREE extras!**

**MANUALS**

Gibson/Operations/Nelson Package - save \$5. All three postage paid (surface mail, printed matter rate) + bonus to first 25 ordering - a copy of SatFACTS Number ONE (September 1994)!

**Tech Bulletins**

9301/9302/9303/9304/9305 (note: does NOT include 9403). Save \$10. All five postage paid (surface mail, printed matter)

**MAN's + Bull**

All three manuals (listed above), all five Tech Bulletins (not 9403[t])- save \$30 (surface mail, printed matter rate) + bonus of "The Wireless Primer" (the full MMDS story) as long as supply lasts.

**Please send the following:**

- TB 9301/\$10;  TB9302/\$10;  TB9303/\$10;  TB9304/\$10;  TB9305/\$10.

OR -

- Gibson/Operations/Nelson Package/\$40;  Weak Signal/Co-Channel/UHF/Interference/ Cable TV Package/ \$40;
- Gibson/Operations/Nelson + Weak Signal/Co-Channel/UHF/Interference/ Cable TV Super Package/ \$65;  SPACE Pacific "Raw Video"/ \$35 (Note: No SPACE member discount applicable this item only). Total of order: \$ \_\_\_\_\_. If CURRENT SPACE Member, multiply by 0.7 for discount total (**not** including "Raw Video") for discount total of \$ \_\_\_\_\_

**I wish to pay this by**  cheque (enclosed)  VISA card  Mastercard

Card number \_\_\_\_\_ - \_\_\_\_\_ - \_\_\_\_\_ - \_\_\_\_\_ expires \_\_\_\_/\_\_\_\_

Ship to (name as appears on credit card): \_\_\_\_\_

Company \_\_\_\_\_

Mailing address \_\_\_\_\_

Town/city \_\_\_\_\_

your signature \_\_\_\_\_

**Return to SPACE Pacific, PO Box 30, Mangonui, Far North, New Zealand or fax 64-9-406-1083**

# SatFACTS MONTHLY

ISSN 1174-0779

is published 12 times each year (on or about the 15th of each month) by Far North Cablevision, Ltd.

This publication is dedicated to the premise that as we enter the 21st century, ancient 20th century notions concerning borders and boundaries no longer define a person's horizon. In the air, all around you, are microwave signals carrying messages of entertainment, information and education.

These messages are available to anyone willing to install the appropriate receiving equipment and, where applicable, pay a monthly or annual fee to receive the content of these messages in the privacy of their own home. Welcome to the 21st century - a world without borders, a world without boundaries.

#### Editor/Publisher

Robert B. Cooper (ZL4AAA)

#### Office Manager

Gay V. Cooper (ZL1GG)

#### Reaching SatFACTS

Tel: 64-9-406-0651

Fax: 64-9-406-1083

Mail: PO Box 330

Mangonui, Far North

New Zealand

Email -Skyking@clear.net.nz

<http://www.satfacts.kwikcopy.co.nz>

#### Subscription Rates

Within NZ: \$60 p/yr

Australia: AV-COMM Pty Ltd, PO Box

225, Balgowlah, NSW 2093

61-2-9949-7417

Elsewhere: US\$60 p/yr

All copies sent via airmail fast post world-wide

#### ERRATA

SatFACTS Copyright 1999 by Robert B. Cooper; any form of copying is a violation of our international copyrights. Advertising rate sheet available upon request.

## COOP'S COMMENT

Page 4 - SatFACTS for January.

"Code of Practice for Victoria includes damaging to satellite business proposals to limit dish size, location. Proposed amendments to Clause 52.19 in 'Victoria Planning Provisions' defines dish antenna, 'A radio communication dish is a circular dish antenna used to send and receive radio frequency communications'."

In March the new rules went into effect. And the adopted rules added a sentence to definitions: "A radio communications dish includes a dish for satellite TV reception."

The Code of Practice apparently began as an attempt to control the spread of telecommunication facilities; microwave transmitters, cellular telephone sites. There were honest concerns relating to potential radiation hazards - microwave dishes connected to microwave transmitters spewing out watts of bone cooking energy. Somehow between the public announced rules and the final adopted rules, the Victoria planners lost sight of their target.

Although the new rules are frequently ambiguous, we believe this is what they mean:

- 1) If a dish is 1.2m in diameter or smaller, it can go anywhere on private property.
- 2) If it is larger than 1.2m, the location can't be visible to any neighbour. It cannot exceed 2.4m in diameter under any circumstances.

3) If it is larger than 1.2m in diameter (not to exceed 2.4m) and will be visible to neighbours, you have to get a building permit to install the dish. This involves either the written consent of the neighbours with the application or publishing a public notice (in a newspaper). The application for a building permit is a killer - detailed site profiles done to scale, written description of the project, arguments why a dish greater than 1.2m is required, engineering statements explaining why the proposed installation location has been chosen (that is, justify why it must go where it can be seen by one or more neighbours). After careful study of what an application must include, we believe you may be looking at up to \$500 in professional studies done by engineers and other "consultants" just to complete the application in the format required.

So what began as an honest attempt to control the careless placement of microwave transmission equipment (which they call a "Telecommunications Facility") has become an obstacle course for anyone desiring satellite TV reception beyond the Austar or Foxtel size dish installation. And all because a bureaucrat, perhaps with the encouragement of someone with an axe to grind in the pay-TV broadcast industry, managed to get 11 words inserted into the Code of Practice.

Victoria is the home of Australia's most ethnically diverse population. Italian, Greek, Chinese - the list is quite long - are more apt to live in Victoria than any other portion of the country. And if these immigrants wish to employ equipment for receiving country-of-origin television, they will have to climb over those 11 words before they can install a suitable satellite dish.

This problem is a perfect opportunity for those who work in the FTA industry in Victoria to come together as a group of professionals to work on getting the 11 words eliminated from the Code. Attempts to determine why and when "A radio communications dish includes a dish for satellite TV reception" was added to the new Code so far have failed to uncover the individual or group responsible. Those 11 words did not get there without some help and they won't leave without an effort.

#### In Volume 5 ♦ Number 58

Peltier Effect LNB Cooling - Practical Tips (Richard A. Brooks) -p. 6

AsiaSat As3S Reality - Not a Perfect Bird -p. 14

Could Alice Springs Become the TV Capital of Australia? -p. 18

#### Departments

Programmer/Programming Update -p.2; Hardware/Equipment Update -p. 4;

SPACE Pacific Report (Get this show on the road!) -p. 20;

Cable Connection (PVR - hard drives for time shifting) - p. 22; SatFACTS Digital Watch -p. 24;

Supplemental Digital Data -p. 26; SatFACTS Analogue Watch -p. 27; With The Observers -p. 29;

At Sign-Off (Trick smart cards out of control?) -p. 32

#### -ON THE COVER-

Inside the LNB. Before you can think seriously about cooling it down, let's take a look at what damage we might do inside (p. 6).

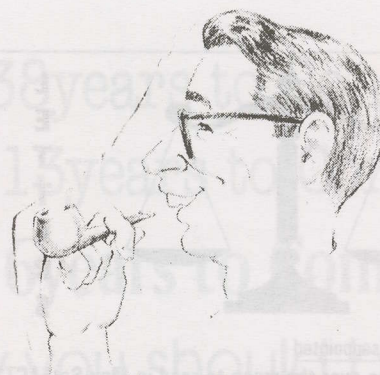

June 15, 1999

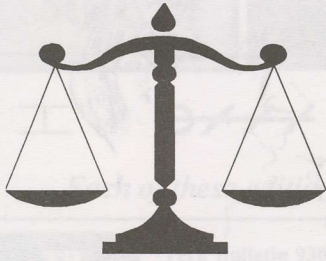

L  
E  
T  
T  
E  
R  
S

Badly Disappointed

"I was over the moon to read in May SatFACTS that up to 12 Star TV Asia channels would be available to us here in Thailand. I have this moment spoken to ASTEQ, the company name and telco you gave in SatFACTS. The information is wrong, they claim. The channels you wrote about are only available to hotels, and other commercial outlets and they say their policy forbidding DTH has not changed. So please confirm your sources as either they or ASTEQ are wrong and many SatFACTS readers will be badly disappointed."

Morris, Bangkok, Thailand

We received several similar notes after May SatFACTS began arriving all over the Pacific and Asia.

Our source was the STAR TV web site (<http://www.startv.com>) and we have reread it again to be certain we read what we did read. We did. The web site makes NO mention of commercial installations, is clearly designed for DTH viewers to wander around and we feel Star should do a better job of posting their limits on who can subscribe. Then we went to Star itself through the various contact numbers on the web site and learned (on the telephone) that their policy does not include accepting DTH viewers in "some countries" at this time. They would not give us a list of "which" countries are included in "some countries" so we hung up and tried again, this time acting like a potential commercial client. We found out that if we were in (for example) Vanuatu we could connect a commercial account such as a hotel to (1) Star World, (2) Viva Cinema, (3) Sky News, (4) Fox News, (5) Channel [V] International, (6) National Geographic for 50 (US) cents per outlet per month per channel. The Pace DVS211 IRDs would cost us US\$475 FOB Hong Kong. We also found out we could have ESPN Sport and Star Sport for US\$.80 per outlet per month but would have to deal with ESPN/STAR in Singapore for this one. Other 'approved' countries have slightly different channel sets, and some channels drop to US\$0.35 per month per outlet. There are different rates for clubs and pubs in the approved countries, always on a per channel basis. We don't fault Star for not accepting home-class clients at this stage (at rates around US\$35 per month, most hotels and commercial establishments would misrepresent themselves as home DTH if they had the chance) but believe they could be more up front with their web site description of who qualifies for their services. So - Morris - get ten neighbours to join you, string some cable and call yourself a motel.

Agrees

"I totally support your stance on no colour in favour of faster turn around of latest facts!"

Stu McLeod, Napier, NZ

You will probably like our new Web site as well (<http://www.safacts.kwikcopy.co.nz>)

PROGRAMMER  
PROGRAMMING  
PROMOTION

UPDATE

JUNE 15, 1999

**Star TV** memo to affiliates is warning NBC bouquet on PAS-2 is scheduled to drop National Geographic service June 15 - after which it will only be available in Asia through the Star digital bouquet. There has been no confirmation from NBC but you will know by the time this arrives in your mailbox.

**Aurora to PNG.** "There is a PhD for somebody who works out what is happening to the Optus B3 signals" according to an executive at ABC. What is happening is unpredictable signal outages that sometimes follow daily-cyclic pattern, sometimes do not (independent of rain outages). ABC, SBS, Central 7, Imparja delivered via B-MAC were important services to PNG cable viewers - the switch to digital has been tantamount to losing these channels to PNG even with an 11 meter dish installed! Moreover, the same problem has hit Norfolk Island with a 10m installed.

**PAS-8 Ku abnormality?** Perhaps. There are reports that while the TARBS to-be-ethnic bouquet on PAS-8 Ku on the Australia beam is very powerful, that two other PAS-8 Asian beam transponders are above digital threshold on a 2.4m dish in NSW. Switch your Ku feed to vertical (opposite of TARBS on 12.562, Msym 28.062, FEC 3/4) and go to 12.286 and/or 12.366 (Msym 26.888, FEC 3/4) and tell us what you see! (You will remember this bird is skewed 17 degrees from normal and "spurious footprints" could pop up almost anywhere.)

**TARBS ethnic bouquet.** "No official announcement of rates, installation charges until July 1" is the unofficial word from the promoters. Try A\$29.95 per month for The Filipino Channel (lifted off of PAS-2 feed) and \$24.95 for some others, many lifted directly from FTA C-band. Comet is in line to do the installations, TARBS is staffed with ex-Galaxy, ex-Optus personnel who claim to specialise in service launches.

**CNN PAS-2 analogue shutdown** scheduled for May 31 delayed by problems at Globecast uplink (Los Angeles) to PAS-8. Seems a hole in their waveguide (transmission line) was leaking RF, didn't find problem until late in May, which bought 15 more days of continued PAS-2 analogue operation. CNN on AsiaSat 3S (3960/1190Hz, Msym 26.000, FEC 3/4) showed up May 21, FTA - but scheduled to go CA (PowerVu) June 15 as well.

**TNT/Cartoon PAS-2 digital service** did shut down (in favour of the new PAS-8 service) on schedule May 31 leaving some commercial clients such as Fiji TV without service. The PAS-8 bouquet uses FEC of 7/8 and TNT (along with EWTN) are simply not reaching as many places now as with PAS-2. Fiji (pay) TV is running tapes of prior transmissions while it tries to sort this out.

**KIBC gone?** No, try reloading it (AsiaSat 2, 3940/1210Vt, Msym 26.655, FEC 2/3). And see announcement concerning SPACE Pacific Report TV show p. 20.

**Hardware names.** California Amplifier has assumed the Gardiner product line while KTI has taken over Orbitron. Sciteq carries them all now.

**Comparison levels.** Using 65cm offset consumer dish with Autosat Dual polarisation 1 dB noise figure LNBF - ACT in Victoria measures Foxtel on Optus B3 at 80 dBuV (12.438Hz), TARBS on PAS-8 at 78 dBuV (12.526Hz), and the Thai Bouquet on I702 at 74 dBuV (12.650Vt).

**Changes?** ABC "Interchange" on PAS-2 Ku is reported to be readying for a move to PAS-8 Ku; we are unable to confirm this.

**C-net Taiwan pay-TV bouquet (C2).** Information concerning subscription from + +886-2-2789-1818.

skandia.com.au

RADIO - 50 Million Users - 38years to Connect  
T.V. - 50 Million Users - 13years to Connect  
INTERNET - 50 Million Users - 6years to Connect

That is 50 million reasons why you should buy a MODEM from SKANDIA.

It's happening fast, and as a valued customer, we would like to help you stay ahead of the rest!

### AusLinx

Supports X2/ITU-T V.90

56000bps Download Speed

Supports V.17/V.29/V.27ter Fax Transmission/Receiving

Supports V.42/V.42bis/MNP Class 2 to 5 Error Correction and Data Compression

Telephone Answering Machine/ Speakerphone

Auto Diagnostic

RS-232 Interface

Free Communication Software

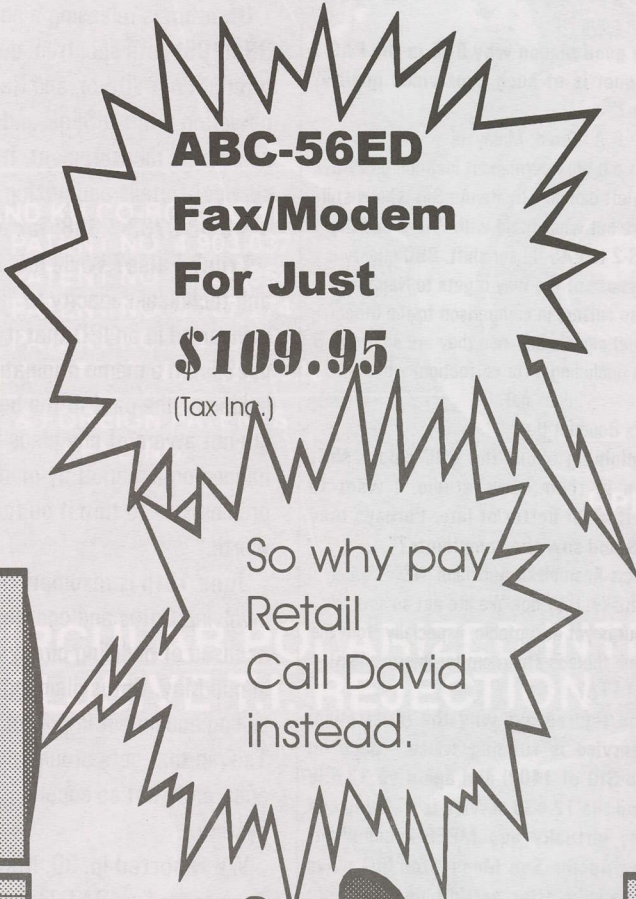

**ABC-56ED  
Fax/Modem  
For Just**

**\$109.95**  
(Tax Inc.)

So why pay  
Retail  
Call David  
instead.

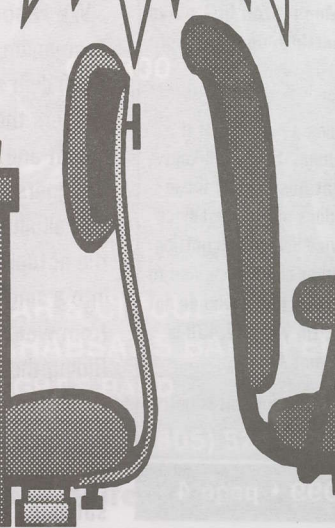
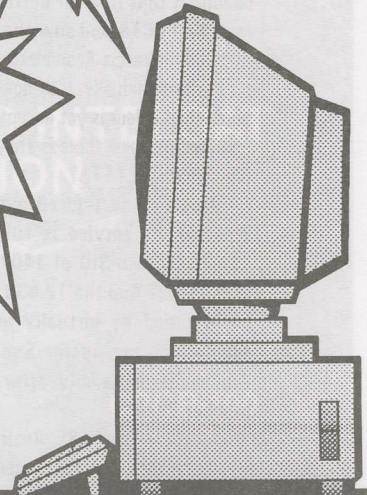

**Skandia Electronics Pty Ltd**  
183 Burwood Road  
Hawthorn, Vic, 3122  
Ph: 03 9819 2466  
Fax: 03 9819 4281

**Or E-Mail Me**  
[david@skandia.com.au](mailto:david@skandia.com.au)

Delivery cost  
not included

Iranian TV

"Reference question in SatFACTS April concerning availability of Iranian TV on As2. I don't think it is still there, not certain it was ever there except for brief tests. The last time I saw it routinely was on PAS-4 Ku band 11.170H. And that won't do the fellow in New Zealand any good at all!"

Gregorio V. Hermosa, Oman

From noon June 2 to noon June 9 on PAS-2 in the C-band California Bouquet, Muslim Television Ahmadiyya was carried as a "test" to the Pacific and Asia. We are unclear why they labelled this a "test" since everyone knows where the California Bouquet goes (and does not go) and if you are where it reaches, the MTA transmissions were merely a dial click away from the likes of CMT and BBC World. MTA was once available to the Pacific on Gorizont at 142E (years ago) and perhaps it will be routinely available again in digital format this time. At this point, there is no official word but you can ask Mr Rafiq Hayat (MTA International) at ++44-171-437-0879 (or fax ++44-171-437-8936).

BBC in California Bouquet

"Is there any good reason why BBC in the PAS-2 California bouquet is of such poor video quality? Don't they care?"

B.A. Kored, Malaysia

They care, want a proper permanent location on PAS-2 and have been left dangling by PanAmSat who is still trying to figure out what to do with PAS-8 and the once solid PAS-2 to PAS-8 user shift. BBC quality is degraded because of the way it gets to Napa for uplinking, also suffers in comparison to the other California bouquet signals because they are all run at 5 Mbit/s bit rate (including error correction) while BBC does not.

BBC in California Bouquet II

"After complaining about the BBC colour shift when they are in their news studio, I want to comment that it is far better of late. Perhaps they read SatFACTS and saw the complaints?"

Francis Kosmalski, Auckland, NZ

Perhaps (actually, they do). We are not so sure we agree their colour is yet acceptable, especially from the studio. We think there is still room for improvement.

Why Weather 21 FTA?

"Has anyone figured out why the (Australian) Weather 21 service is running twice - once on 12.626 (with a SID of 1402) and again on 12.438 (SID 1102)? And the 12.438 service is FTA and can be watched by virtually any MPEG-2 compliant IRD? Also - my Austar Sun Moon Star IRD plays Aurora quite happily after setting up using pin number 2878."

SS, Australia

The W21 FTA service remains a mystery. If it suddenly goes CA shortly after June 15th, we'll know it was a mistake and someone at Austar read these words. Of course we hope that does not happen since there is a measure of public service involved in getting W21 as Australia's only live weather channel service to as many people as possible - including those who do not (or cannot) subscribe to Austar. Oh yes - 12.438 is used by Foxtel services, not Austar.

Note: Some letters edited to fit, but content is not altered.

## HARDWARE EQUIPMENT PARTS

## UPDATE

JUNE 15, 1999

**Praxis IRDs.** Handan, a Korean outfit, created what we know now to be the Phoenix 333 (AD+P) and the Echostar AD2000IP. A Hong Kong / Middle Eastern firm called Praxis bought rights to the same IRD (calling it the 9800ADP) for sale in the Middle East and Asia. But they made a mistake and got their version reviewed first in What Satellite TV (UK) and then Tele-Satellite (Germany) and in direct competition to Echostar offered it for sale in Europe. Echostar responded by convincing Handan they should cut off Praxis totally (yes - the same 9800ADP was briefly available in Australia - perhaps another Praxis "mistake"). The 333 is safe - Satech was in on the ground floor and kept their marketing "at home" which is what Praxis should have done.

**Unaohm** is releasing a new installer level digital + analogue meter (model SBM105) with spectrum display plus critical BER measurements at three levels: Pre Viterbi, Post Viterbi, and Reed Solomon. Symbol rate range 4 to 30, built-in LNB powering (with DiSEqC and 22 kHz switching). Also built in - (analogue) carrier to noise ratio measurement, frequency marking. Know how close you are to losing the service! Details and pricing (not yet announced) from Lacey's Australia (tel ++61-3-9783-2388; fax ++61-3-9783-5767 or Email placey@netlink.com.au).

**True? False?** While it is known that several of the newer IRDs have the software and technical capacity to "link" the smart card to the IRD (by verifying that the card is inserted in an IRD that it was originally mated with), is this procedure actually in use? From a memo originating at a popular pay-TV programmer, this summary. "The linking of the card to the box is a feature that can be enabled on any of our boxes. I am not aware of any plans to enable that capability anytime soon. I'd expect it to happen on a market-by-market basis as a response to the perception of piracy problems as to turn it on for no good reason would cause us more problems than it is worth."

**June 15th** is resumption date for court case in Burwood (NSW) Local Court involving Optus and one Raymond Milland dba Access Satellite Systems. Milland is accused of peddling piracy equipment. Magistrate Peter Ashton heard initial charges in mid-May, Optus claiming Milland has deprived them of \$2.5 million in revenue by selling equipment imported from Taiwan that gets around their apparently not so secure "security system."

**We reported** (p. 30, May) how Tasmanian firm SAT-TV has designed 2.4m dish system for sale to DTH viewers there. Now comes a H to H mount and rotation system which designers say is virtually fail-proof. The all aluminium design integrates the actual dish mover and the mount into a single assembly, well enclosed from weather and the elements. Riding the back of the Imparja TV promotion programme (see p. 18, here) in Tasmania, they are appearing throughout the state with a mobile satellite "Show 'n Tell" display.

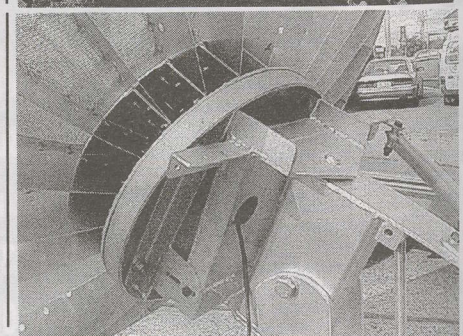



# ADL<sup>®</sup>

BECAUSE PERFORMANCE IS ALWAYS YOUR FIRST PRIORITY

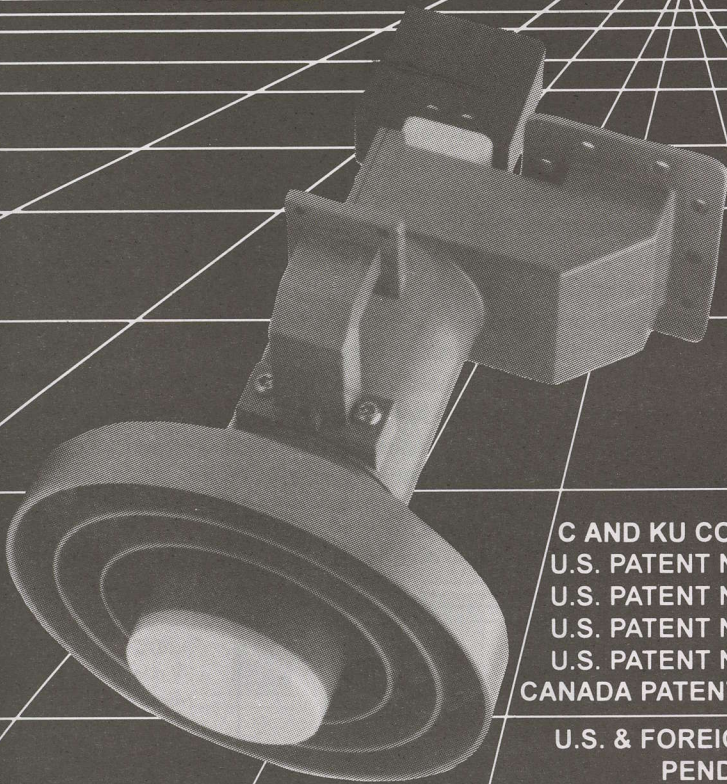

**RP3-CKU/ International  
Adjustable Scalar Ring Feed  
with Extended C Band**

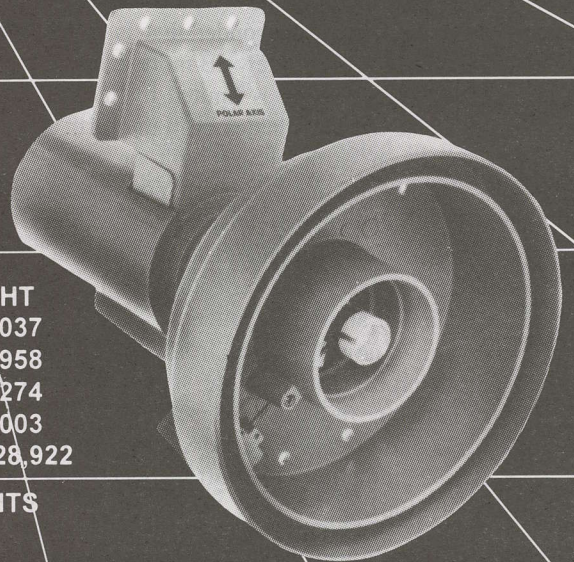

**RPI-CKU Feed**

**C AND KU CO-BORSIGHT  
U.S. PATENT NO. 4,903,037  
U.S. PATENT NO. 5,066,958  
U.S. PATENT NO. 5,107,274  
U.S. PATENT NO. 5,255,003  
CANADA PATENT NO. 1,328,922**

**U.S. & FOREIGN PATENTS  
PENDING**

## **ADL HYBRID MODING CIRCULAR POLARIZED INTELSAT FEEDS WITH EXCLUSIVE T.I. REJECTION**



**RP1-CP400**



**CP-300**



**CPOR-100**

- C BAND LINEAR & CIRCULAR • C/KU LINEAR & CIRCULAR • KU 12 GHz FEEDS
- INTELSAT 4 GHz CIRCULAR • ARABSAT S BAND FEEDS
- OPTIONAL: CO-BORSIGHT S BAND

2216 AGATE COURT, UNIT B, SIMI VALLEY, CALIFORNIA 93065 • (805) 526-5249 • FAX (805) 584-0634

**NEW ADL Web site - [www.adlfeed.com](http://www.adlfeed.com)**

## Peltier Cooling of LNBS - Tips for Experimentation

From the very first crude experiments with small dish reception of C-band signals in 1976 people have been driven by the urge to improve picture quality without resorting to a larger dish. For some the quest is practical - larger dishes often will not "fit" into available space (or attract the anger of neighbours who dislike "seeing" the structure out of their window). For others, it is an endless chase of elusive signals. No matter how big your dish (within reasonable limits) there is always at least one transponder that is just beyond reach. If only you could get just a few dB more gain!

All satellite reception is limited by "noise." There are two types of noise. One originates from the earth and those objects which grow on earth or are built on earth. This is called "earth" or "background" noise. You attempt to reduce or eliminate this category of noise from your receiving system by properly designed feed antennas that "look at" and "see" only the surface of the (dish) reflector - and not the earth which exists behind or around the antenna.

"Thermal noise" comes from the electronic equipment utilised to process the satellite signal. As soon as electricity flows through resistors, capacitors, wire, solder joints, transistors and voltage regulators - thermal noise results. This is a catch 22 situation - shut off the electricity and the flow of electrons stops. No more noise. Also, no more signal processing!

"Thermal noise" level or strength is measured by the rated "noise figure" of the LNB. At C-band, noise figure is expressed in degrees Kelvin. An LNB with a 0 degree Kelvin noise temperature would be noise free - but impossible because electron motion creates noise. By very careful circuit design and even more careful LNB construction, thermal noise can be reduced. *But never eliminated.* At Ku band, a different measurement system exists although the principal is the same. A Ku-band LNB with a 0 dB noise figure would be ideal. In the real world, 0.6 dB is very-very good and 1.0 dB is more common.

Thermal noise - generated by the LNB - is sensitive to the physical temperature of the component parts of the LNB. An LNB will work much better (produce lower noise performance) at the North Pole than it will on the equator. Same LNB, two different locations. Why? Because when electronic circuits are made physically cooler, they create less thermal noise.

Which brings us to artificially cooling an LNB. The LNB (and feed and feed support system) sit open to the elements. Sun strikes the metal parts and warms them. At the same time, those electronic parts inside of the LNB have electrons running

around and that generates heat inside of the LNB. So what happens if you place the LNB into a cooler environment? The case temperature goes down, the component part temperature is lowered, and the thermal noise reduces. In theory - a 1 dB noise figure Ku LNB could become a 0.5 dB noise figure LNB. Or better.

### The Peltier Effect

Thermoelectric (TE) technology is based upon a 19th century discovery. When electric current flows through two dissimilar conductors, at the *junction* of the two heat will be absorbed or released. A semiconductor, such as Bismuth Telluride, is a frequent choice for the material because designers can control the flow of electricity. A Peltier device or thermoelectric module built around a 'pellet' of semiconductor material creates the necessary physics to make it work. A basic module is shown here.

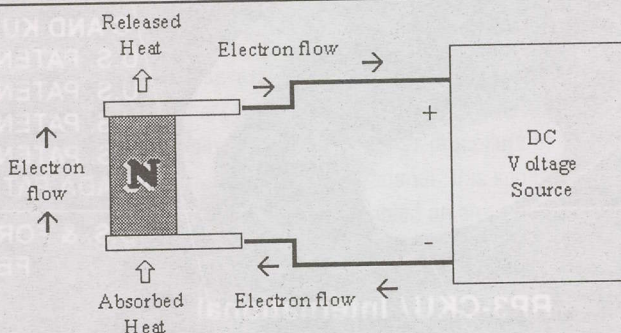

Note (above) the semiconductor material is "N" type. Negative charge electrons produce the bulk of the Peltier effect. How? Electrons are repelled by the negative pole and attracted by the positive pole of the (power) supply. This forces electrons to move in a clockwise direction absorbing heat at the bottom and releasing it at the top. Theorists state, "the heat is effectively pumped through the semiconductor pellet by the charge carriers." If you substitute P-type material for the N-type shown, the direction of heat flow reverses, relative to the flow of electricity. Now you can stack two pellets - one with N-type semiconductor material and one with P-type and have an effective (but small capacity) "heat pump".

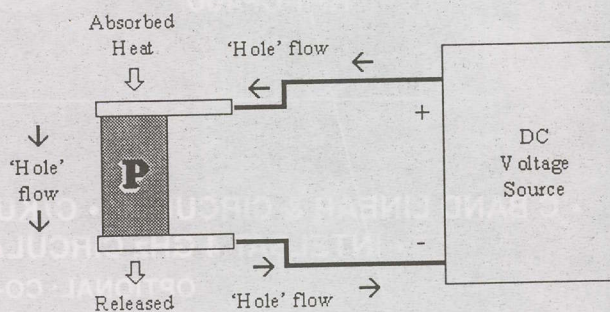

By arranging multiple N and P-type pellets in a 'couple' and forming a junction between them with a plated copper tab, a

from a SPRSCS '99 paper by  
Richard A. Brooks, PO Box 8458, APO, AP 96557  
USA tel + +1-617-981-2462, Email  
brooks@kmmail.kmr.ll.mit

### The practical need for better performance from LNBS

During SPRSCS '98, attendee Horst Wieser (Germany) took a Philips LNBF, wrapped the rear portion in a plastic bag filled with crushed ice and demonstrated how much better reception was on a 1.2m dish. The science project drew suitable praise from attendees who were witnessing for the first time how an LNB(f) can work more efficiently if the surrounding environment is closer to 0 degrees C than 25 degrees C. At SPRSCS '99 attendee Richard Brooks (Marshall Islands, Central Pacific) circulated a "what if" technical paper proposing technology to replace the plastic bag of crushed ice with a permanent mechanical cooler (consistently replenishing the crushed ice is not a very practical consumer option).

Early in May, Australia's Optus satellites shut down analogue B-MAC service for Queensland viewers of SBS, ABC and Central 7. And although the trio of services was intended for use by Australians only, in fact offshore several hundred miles there were others also using these feeds. And where the B-MAC analogue services were working "offshore" on 5m size dishes, the replacement Aurora B3 digital packages not only did not work on 5m dishes, they also would not work properly on 10 and 11m dishes! Getting a few extra dB of "circuit margin" has suddenly become more than a science project for thousands of viewers. Could cooled LNBS provide that extra margin required?

series circuit is created that causes the heat to move in one direction. That is because the electrons flow continuously from the negative pole of a power supply through the N pellet, through the copper tab junction, through the P pellet, and back to the positive pole of the supply. Yet, because we are using the two different types of semiconductor material, the charge carriers and heat are both flowing in the same direction through the pellets (bottom to top in drawing below). Using these special properties of the TE 'couple', it is possible to team many pellets together in rectangular shaped arrays to

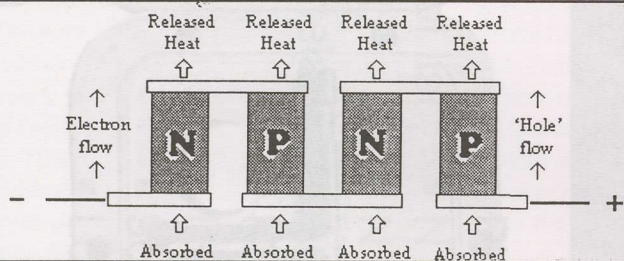

create practical thermoelectric modules. The most common now available connect 254 alternating P and N-type pellets and they run nicely on DC supplies of from 12 to 16 volts and

draw between 4 and 5 amps of current. All of this is well within the range of low-cost power supplies.

#### Practical Problems

When you are attempting to build around multi-pellet arrays, placing the arrays where they will collect and transport away the maximum amount of heat is a challenge. Studies indicate most of the internal LNB heat is generated in the voltage regulator(s), the output driver and the final output stages. Voltage regulators, because they generate several watts of heat, are often physically connected to the LNB enclosure (on the inside of course) which turns the aluminium case into a "heat sink." Think of this as fins on a radiator - heat generated in the hot component part is allowed to travel to the case where the large surface area of the case dissipates the heat into the ambient air surrounding. Unfortunately, in the process, the heat turns the LNB case into a miniature oven, raising the temperature of everything inside.

And that is where the trouble occurs. Internal heat married to solar heating elevates the LNB temperature. And heats the air trapped inside the usually sealed enclosure. Now, while the ambient (surrounding air) temperature may be 25C, the parts and air inside are easily 40C. Hotter parts, more thermal noise.

### Finding your way around inside an LNB

Although they may not "look" alike, virtually all C-band LNBS are designed like all other C-band LNBS; ditto for Ku-band to Ku-band. All have two or three stages of "gain" (amplification) at the input frequency (C or

Ku band) using various formats of field effect transistors (FETs/HMETs). These stages are the primary noise-figure (noise temperature) establishing devices. In photo at left below, the top-centre square and pin soldered to it is the input from the LNB probe; the low noise gain stages are at the right. Next the input C or Ku band signals must be down converted (frequency shifted) to L-band (950-1450+). To make this happen, a "local oscillator" stage creates a signal which "mixes" with the incoming C or Ku band signals to produce a new output frequency at L-band. In photo below right, a "DRO" (dielectric resonant oscillator) - the round gadget - provides the source energy for the mixing action. After the mixing, new output stage amplification (one or more gain stages) before sending the signals to the output "F" connector. Heat? Note the 3-legged square device screwed to the case (upper left in left hand photo) - see text.

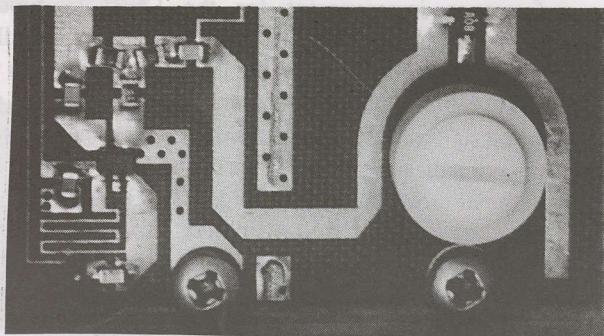
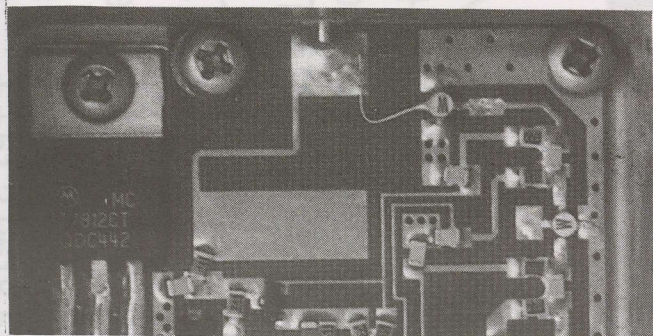

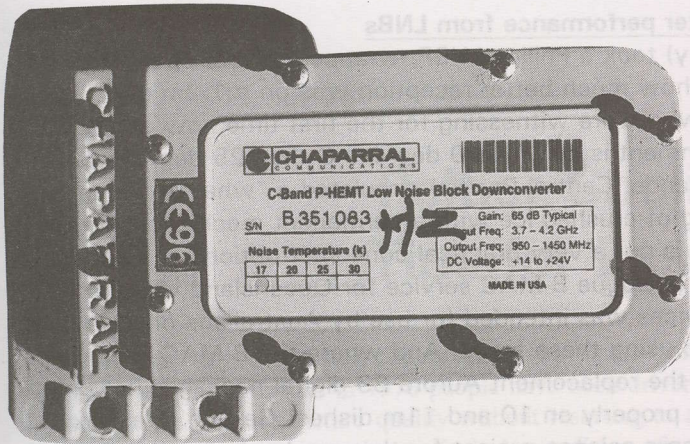

Case entry - some are dead simple, some are not. Chaparral C-band Sidekick has 8 screws to remove and you are inside.

Ideally, the pellet array would be located such that it captures the heat from the voltage regulator(s), output driver and output amplifier (stages) and quickly transports it away before the internal case temperature can be heated.

Most LNB designs don't leave you adequate room inside of the case to mount a pellet array. Moreover, foreign objects implanted inside the LNB are likely to dramatically affect tuning of the LNB causing degraded performance which is potentially more of a threat than the heat.

This suggests the pellet array(s) must remain *outside* of the case, "sucking" the heat away from the case and disposing of it as a means of lowering the overall case (and internal parts) temperature. Is there a mechanical means of holding everything together? Fortunately, manufacturers of Peltier devices have partially solved this problem. A ceramic substrate creates a sandwich forming a thermal interface between the Peltier device and the 'outside world'.

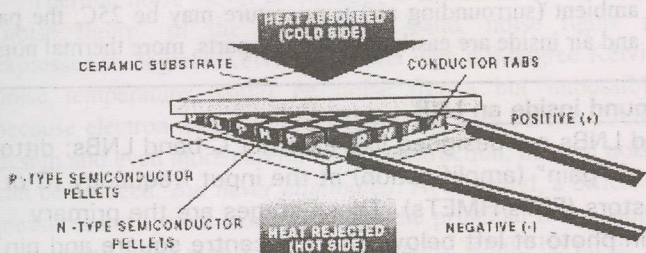

Conceptually, consider the LNB is a rectangular aluminium enclosed container. We want to cool the air inside of the LNB as a means of lowering the LNB operating temperature. If we could 'gather' heat from inside of the box, and release the heat outside of the box to the ambient air, there would be a performance improvement for the LNB. In food cooler devices, two heat sink / fan combinations are installed. One goes outside the box, one on the inside in conjunction with one or more Peltier devices. We cannot install a fan and probably cannot install a heat sink inside of the LNB; there is simply no room, and, the metal of the heatsink fins is likely to cause operational problems with a standard LNB.

In a situation where a heatsink *could* be mounted inside the LNB, it becomes a 'cold side' sink with a larger sink on the hot (out) side. In this case, the Peltier device is mounted on the outside of the case (see right) but effectively between the hot

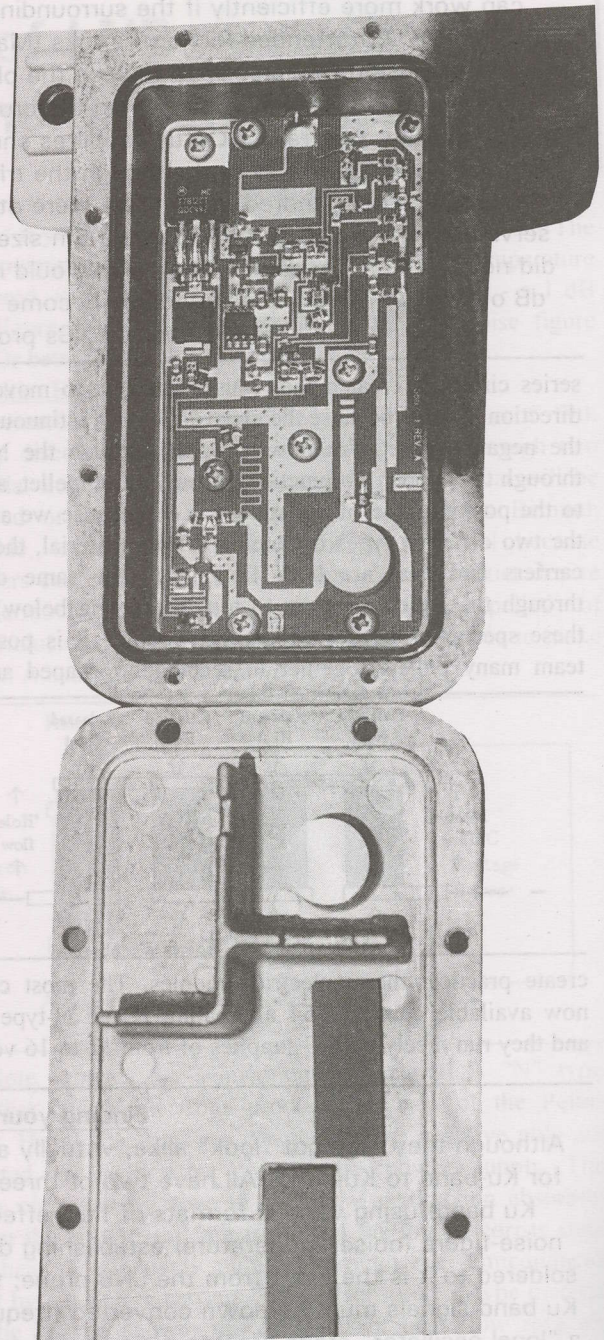

Cover may be *more* than a cover. Those "ridges" cast into the cover do two important tasks: (1) they provide inter-stage shielding to keep each section of LNB electrically "isolated". And, (2) they are a part of the circuit tuning - just like a tuning knob on a receiver, only "fixed" in value.

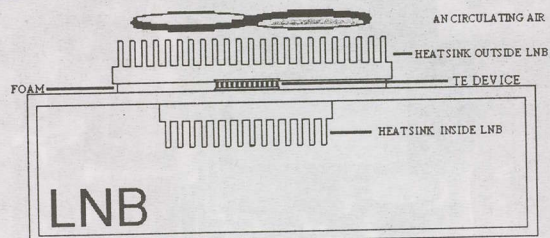

# The Most Advanced Free To Air Digital Satellite Receiver D7-MediaStar

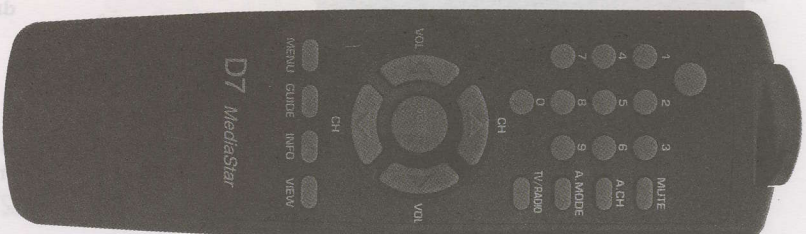
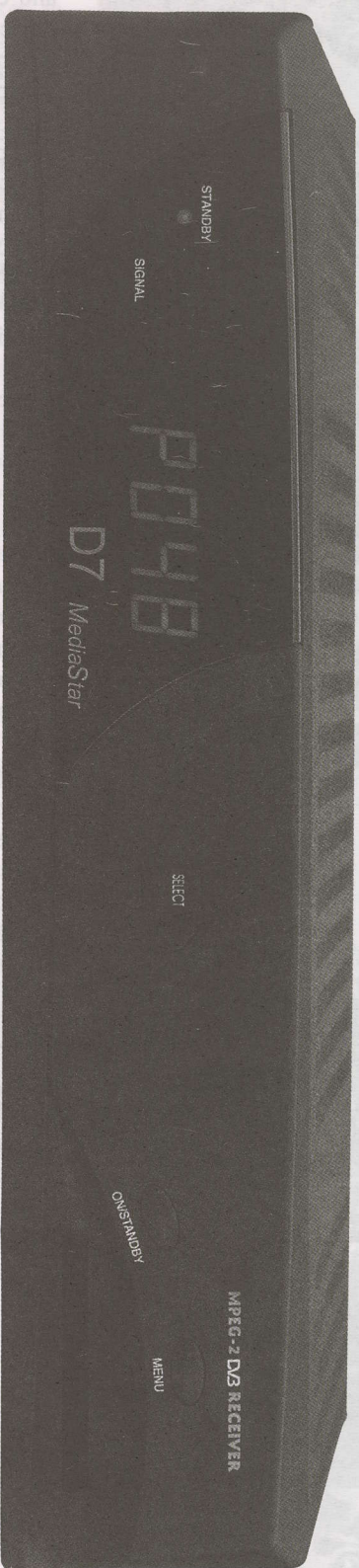

- MCPC/SCPC 2-36 Msym
- Direct channel selection from channel list
- Channel Edit menu Delete, Skip, ON.
- Fast response when changing channels
- No channel over-write
- 200 Video 100 Audio channels
- Automatic search and download
- 22 KHz switch

- PID Menu
- NTSC/PAL Auto switching NO NTSC Glitch
- NTSC converted to PAL-60Hz Free Option
- Audio L, R, Stereo selectable via remote control
- RF Modulator PAL-G, VCR/TV Scarts, RCA Audio/Video, SVHS outputs.
- 90-265VAC-50-60Hz power supply
- Low threshold performance



MediaStar Communications International  
24 Bosci Road  
Ingleburn NSW 2565 Australia

E-mail [opac@bigpond.com](mailto:opac@bigpond.com)  
Tel ++61 2 9618 5777  
Fax ++61 2 9618 5077

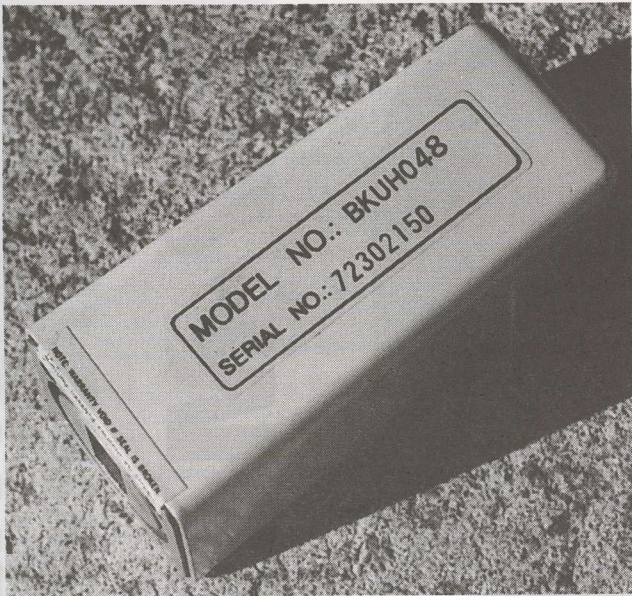

Ku-band LNB (above) separates from weather case by simply removing nut that holds output "F" fitting (in shadow, right) in place and busting paper warranty seal (lower left).

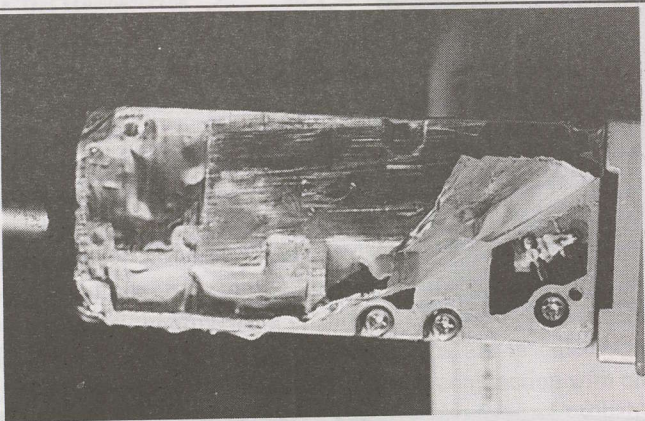
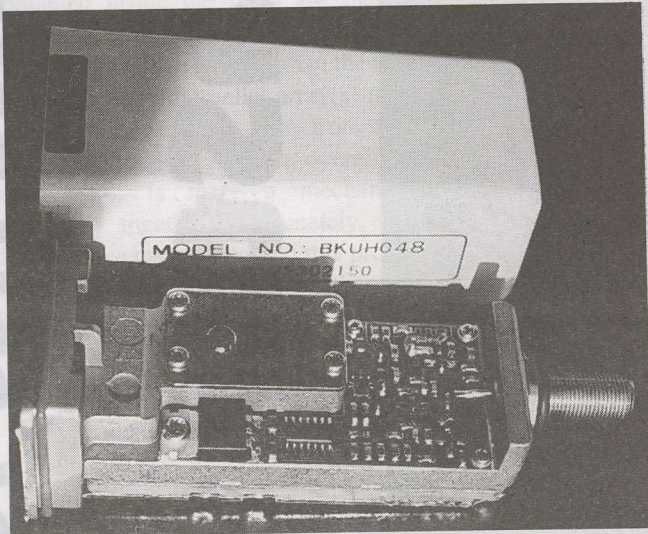

Out of case (middle photo) reveals metal encased (enclosed) "DRO" (left centre), output amplification (pin from "F" fitting, right). Input side? This is a tri-level LNB (see lower photo) with 12 GHz amplification hidden in die-cast compartments sealed with aluminium foil. Think of these stages as potential moisture reservoirs - not good.

and cold side sinks. As direct current passes through the TE device, heat is pumped from the cold side sink to the hot side. A fan on the hot side would then improve hot side fin (sink) dissipation of collected heat.

To create a temperature drop from 20C to 3C inside the LNB will probably require a cold sink temperature of 0C. A Peltier device drawing 4.1 amps at 10.4V will dissipate 25 watts from the thermal load plus 42.6 watts to power the TE module (total - 67 watts). If we install a hot side heat sink with an effective thermal resistance of 0.148C/w, the temperature of the hot side sink will rise approximately 10C above ambient. Note that in creating a 17C drop between the box temperature and ambient requires a 30C temperature difference across the Peltier device.

Unfortunately for the designer, overheating of the TE device is another challenge. If the TE overheats reaching the reflow temperature of the solder, the unit will self destruct. Dissipating hot side heat to air typically requires a fan.

Yes, it might be more practical to use the LNB enclosure as the cold side heatsink. The efficiency would be lower, but no internal access to the LNB would be required. However, lacking cold side heat fins to collect the heat, the LNB case becomes the transfer medium.

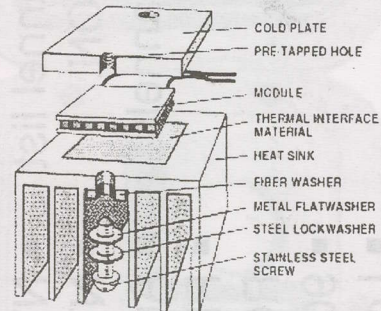

#### How Much Cooler?

A Delta T (hot side to cold side) drop of 75C is theoretically possible. But as a practical matter, a single stage device is unlikely to exceed 30C and 20C might be a better design goal. It is also possible to "stack" Peltier devices but this brings new design problems beyond the scope of this discussion. Perhaps it might not be wise to drop below (or to) 0C anyhow - can you imagine a "frostbite" LNB?

#### Building a Peltier Sandwich

Virtually any design attempting to marry Peltier to an existing LNB will involve 'clamping' the two parts together. Some cautions. TE devices are not terribly strong, will not stand 'uneven' compression. A sandwich with cold plate, TE module, and heat sink requires near perfect surface to surface bonding of three layers.

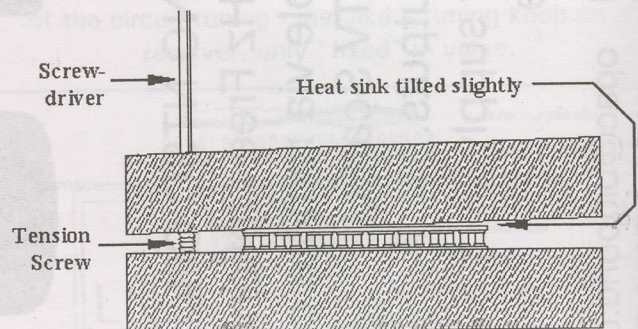

Machine screws could be used providing care is taken to create even compression (pressure) across the full surface to surface line. A common error of first-time TE builders is to tighten one side and then the other. Rather, each side should be adjusted in tandem with the other, a quarter turn each back and forth to maintain even pressure on the module in the middle. Space the tension screws (two shown) to even up the pressure on the TE device.

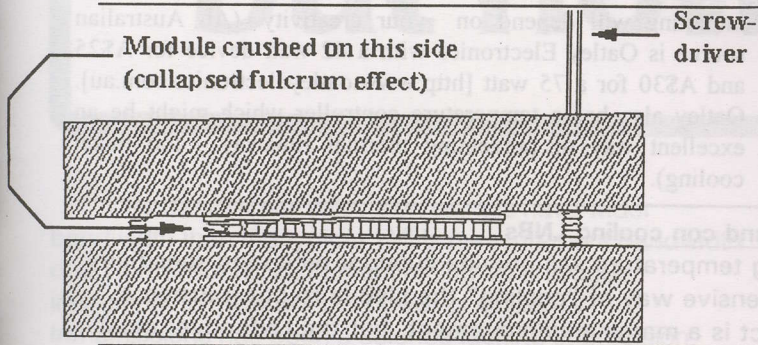

#### Flying Blind

A modest amount of trial and error experimentation could be done with generally locally available parts. By placing two TE devices on opposing flat sides of the LNB, holding them in place with tie-wraps or even hose clamps would at least allow some measurements to be completed (see drawing below).

The area between the LNB and heatsinks, surrounding the TE device, would be filled with a closed-cell foam (use only two-part, not one part) plus a bead of silicone. These should keep moisture out of the TE device (it will fail if it becomes wet). Thermally conductive heatsink compound should also be applied on both sides of the TE device which will improve the thermal path between the heatsink on one side and the LNB case on the other.

#### The \$64 Water Question

If you cool the LNB below the dew point, moisture will condense. There are potentially two water problems.

Water condensing *inside* of the LNB is a proven concern (see SatFACTS May 1999, p. 22). And, water pooling inside of the Peltier (TE) device is equally damaging. TE manufacturers often recommend RTV silicone as a barrier to water ingress to the TE parts. What this overlooks is vapour

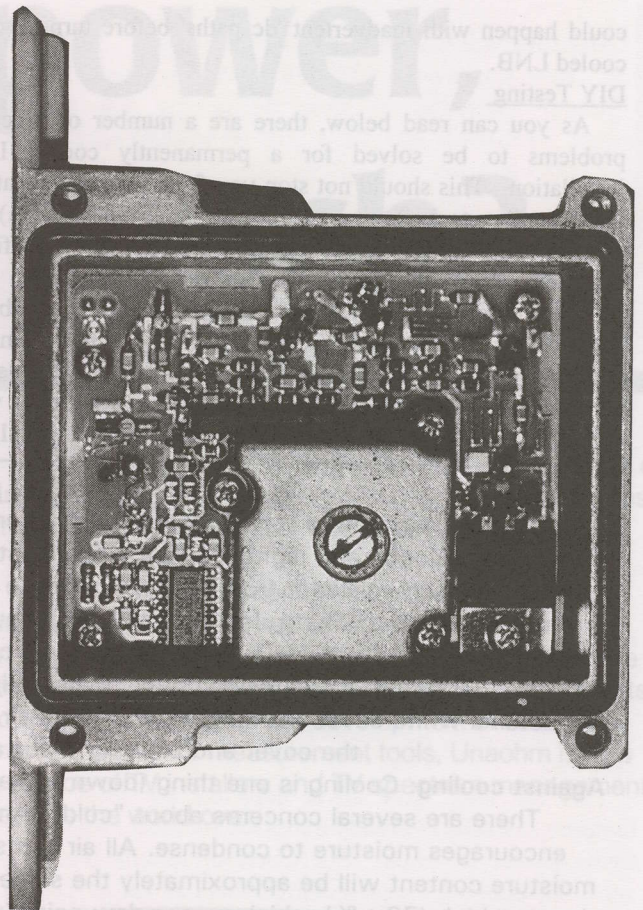
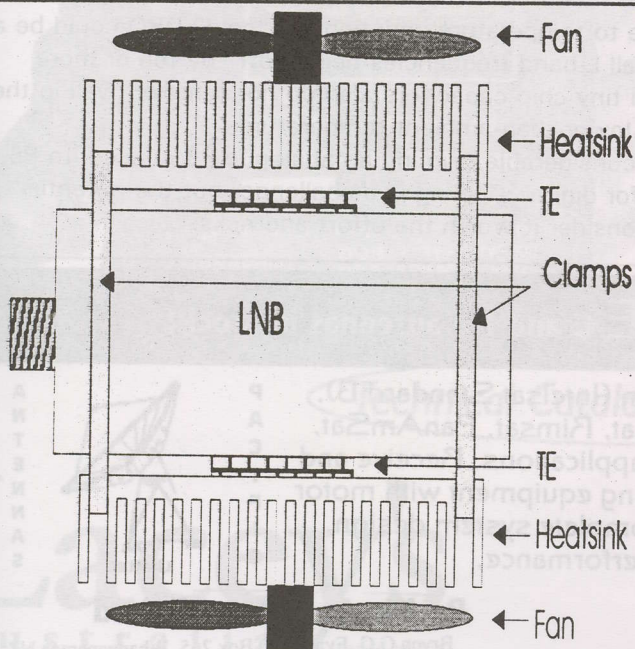

Dynasat C-band LNB has now familiar parts - DRO (bottom, centre), C-band input (left, centre) and heat generating voltage regulator (bottom, right).

migration and the ill effects of moisture laden air trapped inside of the sealed TE device segment before it was sealed up with RTV.

There are only two substances known to be impervious to water vapour - metal and glass. Neither is convenient for sealing thermoelectric devices (on LNBs). One solution offered by Tellurex is a proprietary polyamide epoxy sealant which has proven successful in three year trials.

Effective vapour protection does not stop with a perimeter seal. It is highly recommended that Peltier devices be surrounded by a two-part, closed-cell foam insulation to further seal moisture from the interior of the subassembly. When insulated wire is used to connect power to the Peltier device (and this is typical), it is a good idea to seal the wire leads at both ends to prevent vapour migration through air passages around the leads.

#### Safety concerns

Never power up a Peltier device (even for a 'quick test') unless one side is properly mounted to a suitable heat sink. The heat sink must be capable of dissipating the rated heat transfer. How long could you hold a lighted 60w bulb in your palm? A 60w Peltier device gets much hotter, much faster and without someplace to dump the heat will quickly self destroy.

DC power for the device is typically relatively low in amperage (a few amps) and the voltage similar to that used for LNB powering. With dissimilar metals and electricity flowing, you have the makings of a battery leading to electrolysis at the dish feed and LNB. Look carefully at what is happening or

could happen with inadvertent 'dc paths' before turning on a cooled LNB.

#### DIY Testing

As you can read below, there are a number of practical problems to be solved for a permanently cooled LNB installation. This should not stop you from having a go at the basic cooling technique, carefully noting (writing down) the results, and reporting them to SatFACTS for the benefit of other experimenters.

One quick approach is to purchase and disassemble a portable TE food cooler (Coleman, Igloo are two common brands). Buy the least expensive, typically the smallest, since all contain the basic TE hardware. This will include a (12 volt) power cord for automobile use. As an example - the Igloo

KoolMate Rider 6 quart Thermoelectric Roadster has the system encased in the lid. Remove the screws to access the module. There are a finned aluminium heat sinks attached to both sides; one of these must be detached to remove the module from the lid.

Another source for parts is Alpha & Omega Computers (<http://www.aoc-cooler.com/>). They have small TE devices created for CPU cooling in computers but the heat sinks and mounting will depend on your creativity. (An Australian source is Oatley Electronics with a 42 watt device for A\$25 and A\$30 for a 75 watt [<http://www.oatleyelectronics.com.au>]. Oatley also has a temperature controller which might be an excellent way of preventing thermal runaway - too much cooling).

#### The arguments pro and con cooling LNBs

**In favour:** An LNB with a lower case/ambient operating temperature will provide superior reception sensitivity to both analogue and digital services. The least expensive way of "cooling" the LNB is to put it inside a container which shields it from the sunlight. The effect is a marginal improvement, but the LNB cover must not absorb heat. That rules out any dark colour (such as black) LNB cover - although several antenna manufacturers do provide a black or dark grey cover (black absorbs heat - white does not). An LNB cover that fits "too tightly" creates an "oven" where air stagnates. One simplistic LNB cooling technique might be to install a white cover with a fan that forces air over the LNB at all times, sucking air in at the high end of the cover and blowing it out at the lower (towards the ground) end.

**Against cooling:** Cooling is one thing (down to perhaps 2-3 degrees C). "Cold" is something totally different.

There are several concerns about "cold." Any inside-of-LNB temperature that reaches "dew point" encourages moisture to condense. All air has some moisture content. If the LNB "breathes" freely, the moisture content will be approximately the same inside the LNB as outside. In the tropics, that content can be very high (70+%) which means dew point (when moisture condenses inside the LNB) will occur much sooner (such as 6 degrees C). You want to avoid reaching "dew point" or worse - frost forming. If cooling results in the creation of water inside the LNB, premature failure is likely. Cooling an LNB, allowing it to return to ambient temperature, and then cooling it again is another way of creating moisture - once cooled, the LNB should stay cooled. Draining moisture out of the LNB can help, but then electronics inside may prevent your positioning it such that a low spot inside (where moisture could collect) is not crammed full of delicate electronic parts (see interior photos of LNBs with this report).

One more complex way of preventing moisture condensing is to pump an inert gas - nitrogen is one easily available - under slight pressure (2 pounds reference the atmosphere) into the case. The nitrogen drives out the air and with it the moisture. It is probably easier to pump nitrogen in than it is to totally seal off an air-evacuated LNB (a "vacuum" inside the LNB case means very little air - moisture - is left and therefore cannot condense).

Going "cold" raises the threat that electronic component parts will cease to function as designed. Dielectric resonant oscillators (DROs) produce the local oscillator (LO) frequency required in each LNB to create an L-band IF output. The DRO is in the best case sensitive to temperature variations; a "cold" DRO could be a DRO with a badly mis-tuned oscillator (resulting in all L-band frequencies being "off" by ten or more megahertz). Some miniature electrolytic capacitors and tiny chip capacitors also do not function well in the cold unless specifically designed for lower-than-ambient temperatures.

The cooled LNB rewards - on the other hand - can be considerable, turning an analogue P3 image into P5, giving a 1m Ku band dish the reach of a 2.4m dish for digital. Cooling is a challenge, but the potential rewards are large enough that many consider it worth the effort and risks.

### small, medium and LARGE C and Ku antennas in stock!

Transmit and receive antennas from 1.2m to 13m (Intelsat Standard B). Linear and circular feeds (AsiaSat, Palapa, JcSat, Rimsat, PanAmSat, Intelsat and more) for transmit and receive-only applications. Receive and transmit electronics including inclined orbit tracking equipment with motor drives for elevation and azimuth to 50 tons. Complete system design, fabrication, installation + proof of performance.

P  
A  
C  
I  
F  
I  
C



A  
N  
T  
E  
N  
N  
A  
S

Limited

#### Pacific Antennas Limited

Bryon G.G. Evans, PO Box 265, Whangaparaoa, NZ  
Tel/fax 64-9-424-0841 • Mobile 025-789-160



# Digital power, but how much?

As most digital Television signals have wider bandwidth than the typical 1MHz measurement bandwidth of a TV measuring instrument, using an analogue instrument to measure the power of digital TV transmissions has been a science lacking in precision, until now.

Unaohm has developed an automatic Digital Channel Power measurement system. The user marks the limits of the channel to be measured and then the instrument quickly makes a large number of power measurements across the channel, from which an effective average is calculated, and displayed in a digital format.

The new EP318 from Unaohm offers a wide range of standard analogue and digital TV measurement functions with precision Bit Error Rate measurement options.

If you want instrumentation that can keep you in touch with what is really happening in your systems, consider Unaohm. From more than 60 years experience in the manufacture of electrical measurement instruments and a leading position in the development of DVB compliant digital TV measurement tools, Unaohm is now the choice of TV installers and TV spectrum management agencies the world over.

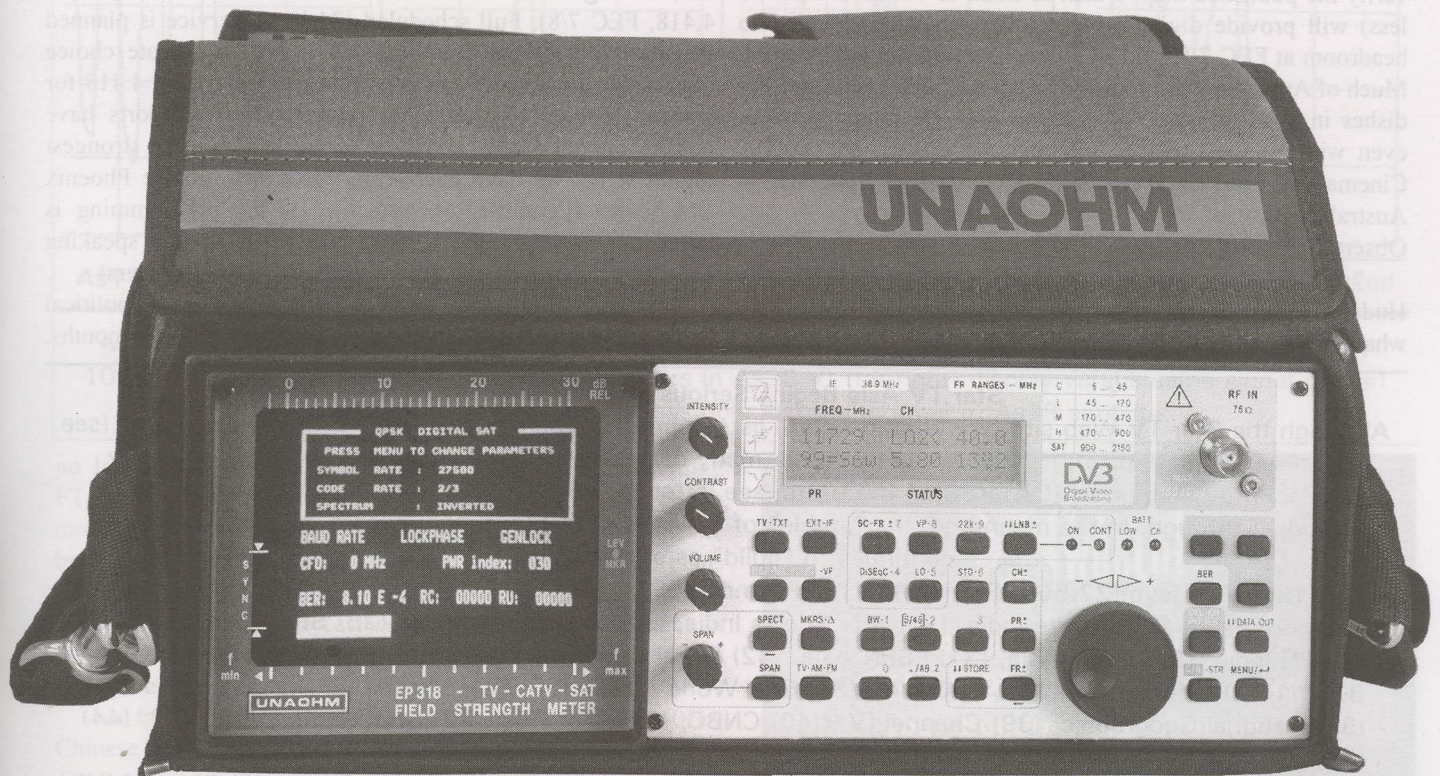

Technical Catalogue available now!

**Lacey's**  
Australia

ACN 006 893 438

12 Kitson St. Frankston VIC 3199  
Tel:(03) 9783 2388  
Int+613 9783 2388

Fax:(03) 9783 5767  
Int+613 9783 5767

e-mail: [placey@netlink.com.au](mailto:placey@netlink.com.au)

Branches in Sydney, Ulverstone & Woolgoolga

## AsiaSat 3S Settles In for the long haul

How do you know that As3S is more powerful into China than As1 was? By noticing that the Chinese authorities began reminding people on May 8th that it is illegal and a crime punishable by jail sentence to have equipment in private hands which is receiving "foreign TV broadcasts." They did this, and Chinese domestic TV showed truck loads of "illegal" C-band TVRO hardware (antennas, Pace IRDs, LNBs, feeds) being hauled down the street against a warning that violation of the 1993 ban is a crime. Hong Kong originated Phoenix TV, by Star TV, seems to be a specific target and a spokesperson there told a Hong Kong newspaper, "*This is not a really good time to say anything; we hope it will not affect us significantly.*" Close-up video shots of the confiscated hardware prominently featured "Made in Taiwan" labels. (As1 levels in China were 32-34 dBw, near the present south-eastern Australia levels from As3.)

As our May issue cover depicted, the most powerful footprint (39 dBw) virtually traces the political map outline of China proper (+ India). Our Observer reports pretty much verify the published map; a dish as small as 1m (at C-band no less) will provide digital service (although with virtually no headroom at FEC 7/8) and analogue P5 reception at threshold. Much of Australia was predicted to have 35 dBw; in fact, 1.8m dishes in Victoria have full lock on Star TV digital services even with an FEC of 7/8 (although, of course, only VIVA Cinema and Star TV News India are available from Star in Australia).

### Observer Reports

"All analogue P5 on 2.2m and Winersat WR850" (D. Hudson, Timaru, NZ). "Everything is P5 on 4m dish - just what Australia needed" (D. Leach, NSW). "All P5 on Phoenix

333 and 3.7m" (Tocsin System, WA). "All signals P5+ on 2.3m" (H. Strecker, NSW). "Nokia d-box with red menu loads 23 TV on 3780Vt, 14 TV on 3850Vt, 24 TV on 3880Hz and 8 TV on 4000Hz. Of course that is the count today only and none of these are viewable here because of CA status" (McLeod, Napier, NZ). "CCTV4 P4, rest P5 on 2.3m and Echostar SR730" (Steiner, Brisbane, Qld). "All P4 or P5 on 3m with Drake ESR 300e" (Beinke, Quorn, SA).

### Errata

The As2 Star services are being shut down, methodically, in favour of the new As3S transponders. The last of the As2 services is scheduled for close down by 1 July; that being the 3700Vt which melds into the 3860Vt (Msym 27.500, FEC 3/4). The 3900Vt and 3740Vt packages have already shut down on As2.

The CNNI bouquet (3960/1190Hz, Msym 26.000, FEC 3/4) is a "carbon copy" of the ApStar 2R 3980/1170Vt service. CNNI, FTA initially, is scheduled to become CA June 15.

Korea's first FTA Asia-Pacific wide ex-pat service, Arirang TV, has begun trial test transmissions on 3755/1395Vt (Msym 4.418, FEC 7/8). Full scheduled (24 hour) service is planned August 12. Although the FEC 7/8 is an unfortunate choice (and makes little sense as there is no room at Msym 4.418 for another channel to share the spectrum), early reports have nothing but good news about the service. "This is the strongest digital signal we have ever seen, 90 to 95% on the Phoenix 111 scale" (Leon Senior, Satech). If the programming is attractive, there will be a rapid growth in Korean speaking users shortly - good news for system sellers and installers!

Will Zee TV and Zee News encrypt? "Because of political upheaval here with no sitting government for last six months.

### Star TV Asia Begins Serious Bouquet Building

Although the Star TV Web site ([www.startv.com](http://www.startv.com)) lists countries where subscription service is available (see SatFACTS May, p. 6), it now turns out that in many cases the services listed as "available" are only available to commercial (CATV, SMATV) users (see letter, p. 2 here). This is obviously a problem to be worked through. In the meantime, the "stable" of services available to *some* users in *some* locations continues to "build" as shown below.

**3860/1290Vt (Msym 27.500, FEC 3/4):** (1) ESPN India (EPG), (2) Star Sports (EPG), (23) ESPN India, (24) Star Sports, (25) Star Sports India, (26) Star Sports India, (27) Star Sports Asia, (28) Star Sports Asia, (29) ESPN India, (30) ESPN Asia, (31) ESPN Asia, (32) ESPN Asia, (33) ESPN Taiwan, (34) ESPN Taiwan.

**3780/1370Vt (Msym 28.100, FEC 3/4):** (35) Star World (EPG), (36) Star Movies (EPG), (37) Star News (38) National Geographic, (39) Channel [V], (40) CNBC, (41) Star Plus, (42) Star Movies, (43) 509, (44) 508, (45) 505, (46) 504, (47) 503, (46) 504, (47) 503, (48) 502, (49) 501.

**3880/1270Hz (Msym 26.850, FEC 7/8):** (3) Viva Cinema, (4) Fox News, (5) Sky News, (6) Channel [V] International, (7) UKtv, (8) Star World, (9) Viva Cinema, (10) UKtv, (11) Sky News, (12) Fox News, (13) Movies International/China/S, (14) Channel [V] International.

**4000/1150Hz (Msym 26.850, FEC 7/8):** (15) Movies International China/S, (16) National Geographic, (17) Channel [V], Taiwan, (18) Star Movies International Taiwan, (19) Star Movies, (21) Phoenix Movies, (22) Subtitle Test (Phoenix Movies) ( EPG)

Note: Different IRDs load some or all of these in different order (this list from an UEC 642). Multiple listings of the same service (such as ESPN Asia, 3860) indicates same video, *different audio* (language) transmission planned.

### This Cross-Pole business - what it means

The key phrase is "frequency reuse." Because an LNB antenna probe aligned for an incoming horizontally polarised signal will ignore any vertically polarised signals even in the same frequency band and from the same satellite, modern satellites use the same C-band downlink frequency band (3.620 - 4.200 in the case of AsiaSat 3S) twice; one set of transponders sends out vertically polarised service, another sends horizontal.

Most feeds (whether rotating probe driven by a servo motor, fixed probes that switch on receiver command, or ortho-mode for simultaneous reception from both polarities) have no difficulty "nulling" the opposite polarity to the extent that when nulled, you

cannot "see" or "measure" the unwanted side. But suppose the unwanted side is actually "leaking" through the satellite? Some of the horizontal signal ends up being rebroadcast by the vertical side and vice-versa. Then what?

Well, you can't null it. Which means when you are trying to get a clean signal off of one side, you also end up with "signal leakage" from the opposite side. Which is what tests to date indicate is happening with As3S. Where this will hurt is when there are signals on most transponders on both polarities and the two-way leakage causes interference between services. The answer to this problem may be there is no answer.

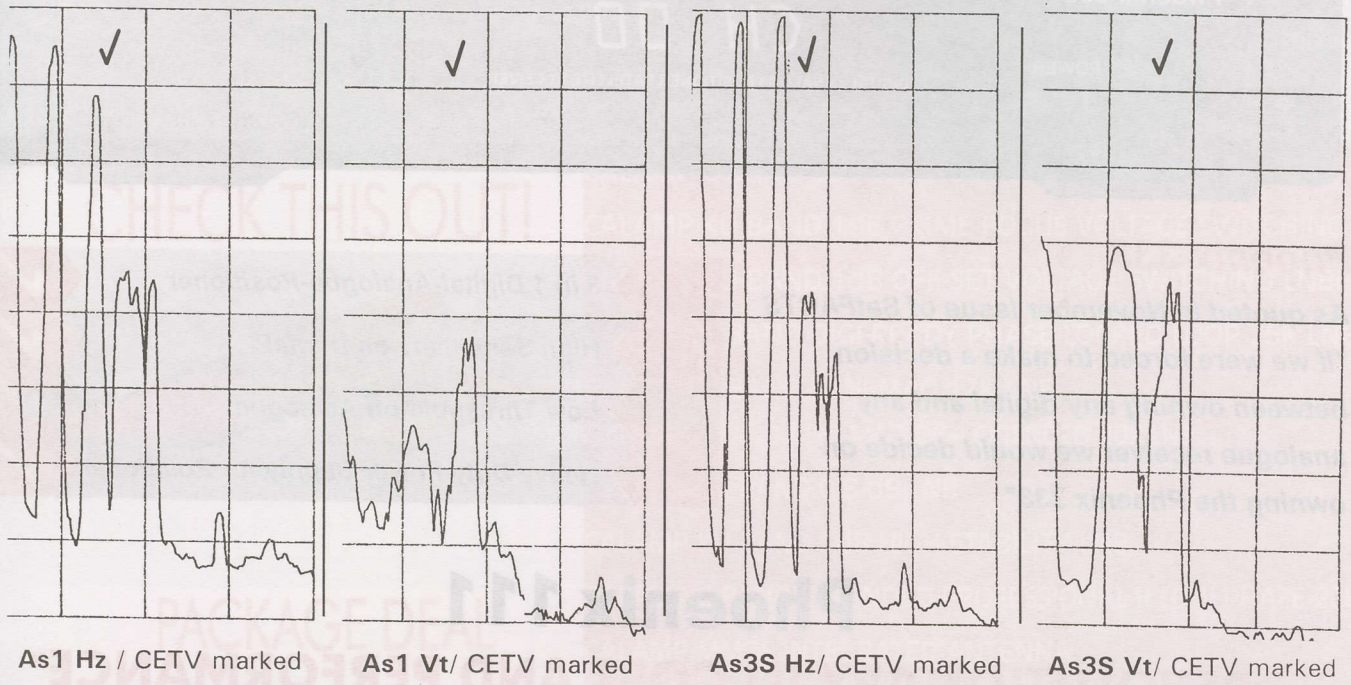

Measurements made in Singapore on 5m dish of As1 Hz and Vt (May 6th, before changeover) and May 10th (after changeover). Note how CETV appears in As3S Vt (far right) display versus same signal on As1 vertical (second from left); cross pole leakage internal to As3S satellite.

no Indian decision maker can really make plans concerning FTA or CA. It is simply unthinkable here in India at the moment to deal with issues like this. Most domestic broadcasters here start with their internal (inside India) plans and then take those plans abroad. So you can report that, 'It is expected that Indian telecasters will not make any changes in their signal until the Indian Broadcast Bill is adopted - not anticipated before Christmas or January'."

Ku band tests are reported on 12.300Vt and 12.460Hz; Chinese beam.

#### The game plan

As1 carried Star Sport, Phoenix, Channel [V] and Star World free to air. Star World was shut down only hours prior to the As3S switchover and an announcement (see right) appeared. Star wants SMATV systems, especially in Hong Kong, to convert to digital for all of these channels. By taking Star World off of FTA analogue, they hope to speed this transition along. Those remaining FTA are scheduled to leave analogue in favour of digital - it is just a matter of time. No

Star TV FTA analogues will remain on As3S when the transition to digital is complete.

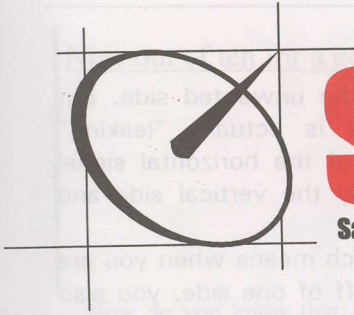

# SATECH

Satellite Communication Technology Pty. Ltd.



## Phoenix 333

**"THE BENCHMARK IN A NEW GENERATION"**



### Phoenix 333

As quoted in November Issue of SatFACTS  
*"If we were forced to make a decision between owning any digital and any analogue receiver we would decide on owning the Phoenix 333"*

3 in 1 Digital-Analogue-Positioner

High Sensitivity on Digital

Low Threshold on Analogue

Heavy Duty Power Supply for Positioner



## Phoenix 111

**"REVOLUTIONARY IN COST AND PERFORMANCE"**

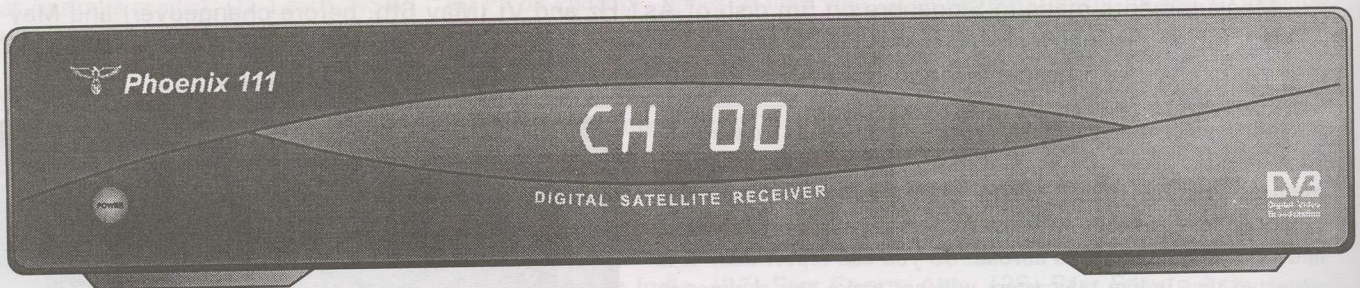

### Phoenix 111



Power Supply and Software  
Specially Designed for  
Australian Conditions

Digital

High Sensitivity Loop through Tuner

Built in Digital NTSC to PAL Converter

Heavy Duty Power Supply



Sole distributor for Phoenix Worldwide



# SATECH

Satellite Communication Technology Pty. Ltd.

Head Office: 6/477 Warrigal Road Moorabbin East Victoria Australia 3189 Ph: 61 3 9553 3399 Fax: 61 3 9553 3393

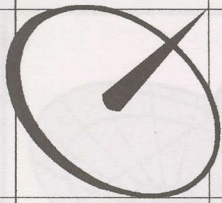

# SATECH

Satellite Communication Technology Pty. Ltd.

**One Stop Shop**

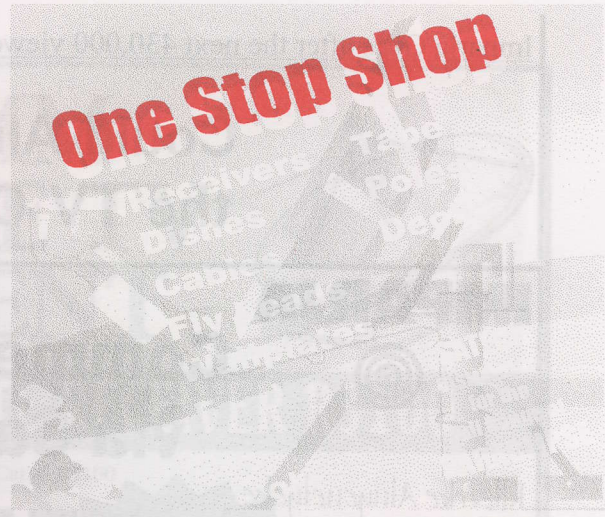

## ATTENTION!

This is not a clearance sale  
of our old stocks like other companys'

**BUT**

a genuine sale for 1 month only!

## SATECH

**Distributors for the  
Full Range of CALAMP**

## CHECK THIS OUT!

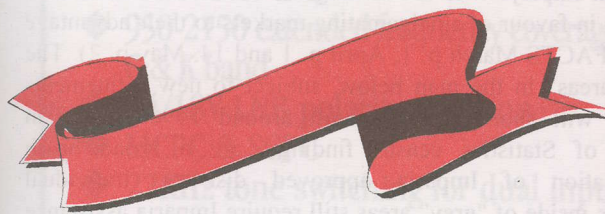

## PACKAGE DEAL

2.3M Polar mount dish  
Phoenix 111 digital receiver  
17k Voltage switching LNBF

**\$799.00  
ex tax  
plus freight**

- CALAMP C BAND 25K VOLTAGE SWITCHING LNBF
- CALAMP KU BAND 1dB PRIME FOCUS VOLTAGE SWITCHING LNBF
- CALAMP KU BAND 1dB OFF-SET VOLTAGE SWITCHING LNBF
- CALAMP C BAND DIGI-READY PHASE LOCKED LOOP 25K LNB
- CALAMP C BAND MINI-MAG 17K LNB
- CALAMP C BAND MINI-MAG DIGI EXTENDED 20K LNB
- CALAMP KU BAND 0.8 dB LNB
- CALAMP KU BAND 1dB HIGH STABILITY LNB
- CALAMP C BAND EXTENDED PROFESSIONAL II LOW PHASE 20K
- CALAMP MMDS INTEGRATED ANTENNA

**SATECH your No.1 Paraclipse distributor  
for the complete Paraclipse range**

### Paraclipse Dishes

- Exceptional strength and wind resistance
- Accurate reception

**WHEN  
QUALITY  
COUNTS**



**Paraclipse**  
HIGH PERFORMANCE ANTENNAS

**All products available through the following SATECH Distributors:-**

Southern Satellite - South Australia -Tel: 08 8377 0955

Norsat - Western Australia -Tel: 08 9451 8300

Network Satellite Services - NSW -Tel: 02 9687 9903

Satech - Head Office Melbourne Victoria -Tel: 613 9553 3399

# Could Alice Springs Become the TV Capital of Australia?

**IMPARJA**



Rlerrke Alnyenetyeke  
Keeping Strong

## Commercial Television via Satellite to rural TASMANIA



Aboriginal owned Imparja TV has done its homework, identifying all of the areas in Australia where Capital City broadcast networks 9 and 10 do not reach - either directly or through regional affiliates. And they have produced a map (see below) which spells out "white areas" - regions where Imparja satellite service can be authorised without any special permission.

Now Imparja is teaming with regional and local equipment distributors and dealers to get the message out to potential viewers. Recently, Imparja supported local Tasmanian distributors of satellite equipment during the AGFEST 99 show. A colourful brochure headlined "(Imparja) Commercial Television via Satellite for Tasmania" identified regions and communities where Imparja authorisation was automatic - just put in a dish and have the service turned on. Dealers such as Western Video Pty Ltd (Kings Meadow) report, "The support

has been nothing short of fantastic, producing brochures, bumper stickers (above) and sending down station personnel to help us explain satellite TV and Imparja service."

The brochure succinctly explains to consumers what their options are if they live in "unserved or under-served areas." As SatFACTS has been urging for several months, there is a "marriage" here between equipment dealers/installers and the people at Imparja who are turning the December 1998 ABA decision in favour of amalgamating markets to their advantage (see SatFACTS March p. 1, April p. 1 and 14, May p. 2). The "white areas" in the map below, subject to new refinements Imparja will shortly release built around 1996 Australian Bureau of Statistics census findings, are a broad brush identification of Imparja approved districts. Individual locations inside of "grey" areas still require Imparja assistance for approval; telephone 1300-301-683.

**IMPARJA**

Rlerrke Alnyenetyeke  
Keeping Strong

**IMPARJA TELEVISION**  
Head Office  
Telephone: (08) 8950 1411  
Facsimile: (08) 8950 1422

*\* Indicative interim map. The precise details are defined in the respective ABA report.*

SatFACTS June 1999 ♦ page 18

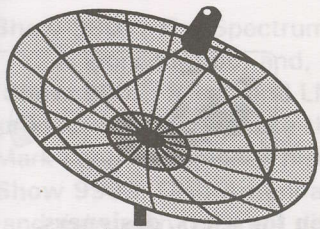

# AV-COMM SATELLITE TV EQUIPMENT

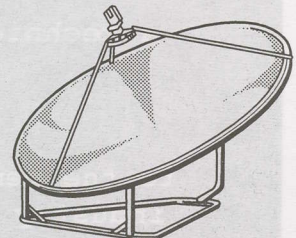

## FREE TO AIR DIGITAL SATELLITE RECEIVER R3100

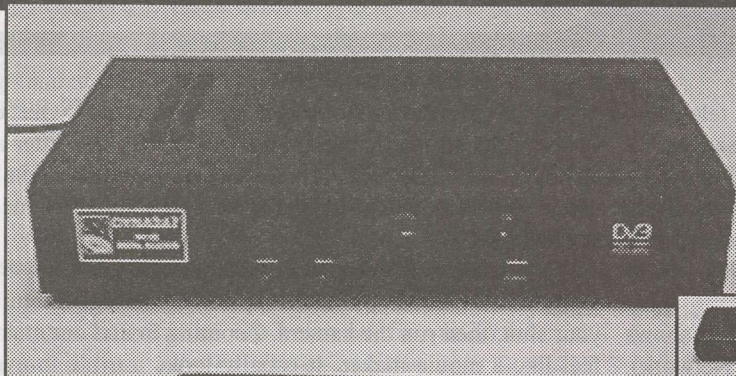

Cat # R3100

**ONLY**  
**\$1145**

Call  
for  
export  
price

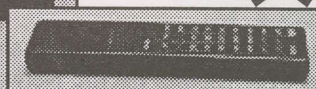

### FEATURES

- ◆ 950-2150 extended frequency coverage, C & K band
- ◆ 14/18V LNB polarity selection
- ◆ MCPC & SCPC
- ◆ 22KHz tone switching for dual input ops.
- ◆ Downlink signal margin indicator
- ◆ Dual channel audio
- ◆ Channel "edit" facility
- ◆ 0-12V output for dish selection
- ◆ S-VHS video output
- ◆ Auto FEC detect

## DYNALINK MANUAL TUNED RECEIVER R1100

### SPECIFICATIONS

- ◆ 950 - 2050MHz IF Input range
- ◆ Low threshold operation
- ◆ Stereo audio
- ◆ 14/18V LNB switching
- ◆ 18/27MHz IF Bandwidth.

Ideal for band scanning, channel monitoring, or as the heart of any home satellite receiving system.

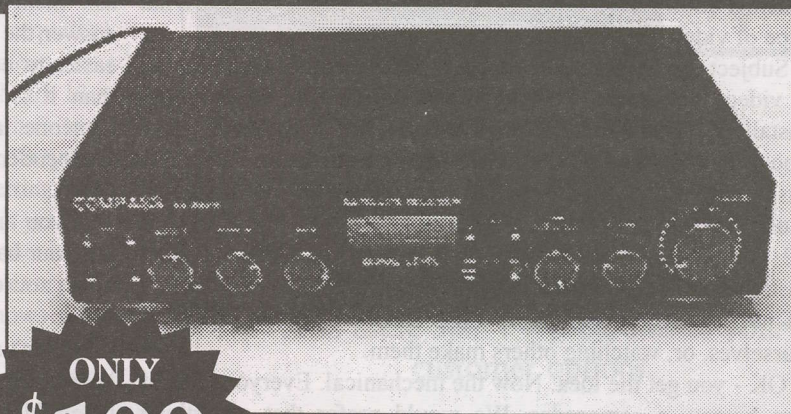

**ONLY**  
**\$199**

Call for  
export price

Cat # R1100

## AV-COMM PTY. LTD.

DIRECT IMPORTER ACN 002 174 478  
PO BOX 225, BALGOWLAH 2093

TEL: 61 2 9949 7417 9948 2667

FAX: 61 2 9949 7095

VISIT OUR WEB SITE AT

<http://www.avcomm.com.au>

\*We reserve the right to improve product performance without notice.

✓YES GARRY, Please send me more info...

Name: \_\_\_\_\_

Address: \_\_\_\_\_

P'code: \_\_\_\_\_

Phone: \_\_\_\_\_

a technical and marketing  
advisory

## memo

to the membership from your  
industry trade association

## SPACE Pacific

Satellite  
Programme  
Access  
Committee



A trade association for users, designers,  
installers, sellers of private satellite-direct  
systems in the Pacific Ocean & Asia Regions

### Get this show on the road!

The first four SPACE Pacific Report one hour television programmes are in final editing as this issue of SatFACTS heads for the printer. The shows combine materials shot during SPRSCS '99 with subjects such as spectrum analyser instruction and a few video contributions from our own Mark Long. A quick summary of the content of shows 9901 - 9904 appears on the opposing page.

About the time you are reading these words, the four shows will be arriving at KIBC and SPN (Sports Pacific Network). KIBC will notify us of their schedule dates and we will in turn notify you (see box on next page). Once this series begins to appear routinely, advance schedules will appear here in SatFACTS each month.

A number of readers have sent in videotape of material which they suggest might be useful in future shows. SPACE member Brian Watson (Western Video Pty Ltd, Tasmania) shot video of the satellite TV booths set up during AGFEST 99 (a Tasmanian farm/consumer show) which happens to include first-time video from the newly named "Tassie Devil" antenna (SatFACTS May, p. 30 and this issue, p. 2). What type of video are we looking for?

Subject matter first. A Victoria SPACE member is producing a video that shows "a typical day in the life of a Foxtel installer." Sound dull? Watch him fall off a tile roof. How about the trials and tribulations of trying to make an 10 or 11m dish play on Aurora service "far" outside of mainland Australia? Or assembling a 5m PanAmSat dish for PAS-2 & 8? Another Australian dealer is collecting video of "bad installations" - systems done poorly, guaranteed to raise the ire of neighbours and councils. We learn by making mistakes ourselves, or watching others make them.

OK - you get the idea. Now the mechanical. Everyone has or can borrow a camcorder. We would prefer that everything

turned in for consideration be shot on S-VHS if in analogue, or in one of the newer consumer digital formats. Our editing system does all final editing digitally (this is 1999 after all!) so analogue materials first have to be converted to digital, time coded and then put through the editing routine. Some quick suggestions:

1) If you are new to camera work, don't do the following - Don't use the zoom when the tape is recording. Zoom in, get your shot, then run the camera. Zooming in and out makes you feel like a movie maker. It usually looks terrible to everyone except the guy or gal who shot it. When in doubt, don't zoom either in or out. Don't pan (move the camera sideways) against static objects (like the side of a building or a stationary dish). Pan the camera to following *moving* objects only. If you are panning a scene, do it very slowly, preferably with your camera on a tripod.

2) Do-do the following. Speak up when you are shooting. tells us what we are looking at. We may (or may not) use your voice track. If we don't use it, we will at least understand what we are looking at. Talk a lot. If there are people being taped, ask them questions from behind the camera and let them answer the questions fully before asking the next one. It is far easier to edit around a long monologue (one person talking) than it is to try to cut in and out around interruptions to someone talking. Yes, we can edit the audio and the video independently and using one does not marry us to using the other.

If you are in a noisy environment, move someplace else, or put your back (and the rear of the camera + microphone) to the noise source. If it is windy, get the camera mike out of the wind.

3) Don't send us a VHS "dub" of your work. Make a dub and keep it. *Send us the original.* VHS (even Hi-8) won't tolerate many "dubbing downs" before it falls apart. If we have your

## MEMBERSHIP IN SPACE

Membership in SPACE Pacific is open to any individual or firm involved in the "satellite-direct" world in the Pacific and Asia regions. There are four levels of membership covering "Individuals," the "Installer/Dealer," the "Cable/SMATV Operator," and the "Importer/Distributor/Programmer."

All levels receive periodic programme and equipment access updates from SPACE, significant discounts on goods and services from many member firms, and major discounts while attending the annual SPRSCS (industry trade show) next March. Members also participate in policy creation forums, have correspondence training courses available. To find out more, contact (fax) 64-9-406-1083 or use information request card, page 34, this issue of SatFACTS. Page space within SatFACTS is donated each month to the trade association without cost by the publisher.



### The first four shows - how to find the schedule

**Show 9901:** The Spectrum Analyser - how to make it work for you, and, It is your signal too.

**Show 9902:** Feeds and LNBS - how to understand product specs and make the correct selection, and, Mark Long's thumbnail history of home satellite TV.

**Show 9903:** Dish Antenna Critique - what is wrong and right with different dish antenna designs, how you make better choices, and, Mark Long - a funny thing happened to me on the way to satellite TV, and, Richard Brooks on the end of the VHS tape era as PVRs enter the marketplace.

**Show 9904:** What is the Market - a discussion of who buys satellite dishes and why they buy, and, Understanding Tiny Parts - a look at fittings, splitters, cable and other 'harmless' creations. To find out when these shows are scheduled on KIBC or SPN, make certain you have your Email address on file with SatFACTS (send your address to Skyking@clear.net.nz). We will be posting notices as soon as we have confirmation from the broadcasters. And/or, check out the new SatFACTS Web Site (<http://www.satfacts.kwikkopy.co.nz/>) anytime after June 22. By the July SatFACTS we hope to have an advance schedule worked out with at least KIBC (AsiaSat 2) which will become a regular fixture on this page.

original, we can go to digital for editing only one generation (of tape) away from the master tape. A second generation (dub) is significantly degraded and by the time we get it on air, quality is lost that cannot be rejuvenated.

Are there any "taboo" subjects? Two answers - we haven't found one yet and yes - we can (and will upon request) keep the identity of the tape's creator confidential. Someone asked if we would run a tape of them showing how their Mark 13 smart card creator works. They wanted to demonstrate how to take a stock (Austar) card and turn it into a "watch everything on Austar and Foxtel" piece of plastic. That's getting close to taboo - but we haven't seen their "production" yet and will reserve final judgement until we do. Sometimes there is a very fine line between "education" and commercial thievery.

Commercial advertising. In the first four shows there are three "sustaining" commercial sponsors. They are (alphabetically) AV-Comm Pty Ltd., SATECH and SCITEQ. Commercial support goes directly to the costs associated with producing SPACE Pacific Report - there is no "profit centre" here and even the commercial firm doing the final editing is doing so on a donation basis. For those who cannot tune-in the broadcasts and make their own off-air tape dubs, there will be digital to VHS one generation removed dubs available starting in next month's SatFACTS. And proceeds from sale of these dubs will also go directly to the production costs for the show.

Finally, materials created for SPACE Pacific Report are being shared with the Dr Dish European counterpart television show which re-debuts this September in digital format on an Astra satellite over all of Europe.

This project is all about who we are, what we do, and how we deal with our own industry's problems. You are invited to be a participant even if you limit yourself to sitting in front of the TV set each week for one hour.

## **YOUR QUARTER PAGE display advertisement here ...**

...would have been  
read by

FTA DTH dealers,  
CATV/SMATV operators,  
satellite broadcasters  
and satellite groupies  
living in 54 countries...

...at a cost as low as  
**US\$76.94 per month.**

Advertising lets potential  
customers know you exist.

Details from tel ++64-9-406-0651, fax  
++64-9-406-1083, Email Skyking@clear.net.nz

### **PUT STAR POWER ON YOUR SIDE**



**Star VIVA Cinema (Filipino)**  
&  
**Star India News (Hindi & English)**

**C-BAND SUBSCRIPTION TV!**  
Add these Star TV programs to your  
customer options.

Star TV Decoders and subscription now  
available under license (Australia only).

**Inquiries sought from established,  
creditable satellite installers/retailers only.**

Please inquire to:  
Bill Khan, **Solution 42 Pty Ltd**, PO Box  
461, Ingleburn NSW 2560  
Ph 02-9820-5962; Fax 02-9820-1769  
Mobile 0411 122 427

# The CABLE Connection

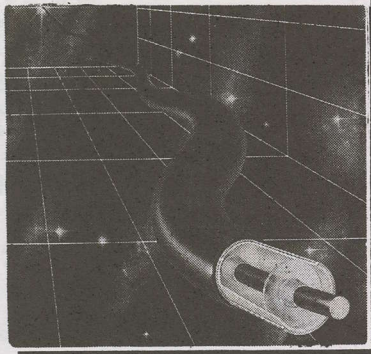

## TV Browser - hard drives for video

As wonderful as VHS (and its many variants including S-VHS) may be, anyone who has to create a system that depends upon video recording and playback as a part of a commercial system of distributing entertainment and information knows it is a less than perfect technology. More importantly, it cannot record and playback simultaneously and although people call it a time shift machine, it is more of a suspended animation device.

Comes now Personal Video Recorders (PVRs for short). They have replaced tape with gigabits of hard drive memory and like any reasonably software powerful personal computer, a PVR allows you to record and view at the same time.

An example: The viewer is watching a sporting match and the telephone rings. He could push record on a VCR and go to the phone, and when done come back and restart the match delayed by the time of the call. But the minute the play button is pushed, the recording function ceases. With a PVR, same scenario. Now re-enter the match after the call, push play while the recording continues to move onward. If the viewer fast forwards through commercials, slow play moments, he can catch up to "live action" in a few minutes time.

PVRs are now on sale in North America. They range in price from US\$499 to US\$1,499. They use hard drive memory (up to 20 gigabits presently, 36 by the end of the year), digital compression, and take an analogue input from a built-in tuner to convert the selected programming to digital storage and when told to playback output in analogue again. There are two serious consumer PVR manufacturers, both Silicon Valley start-up firms closely corporately connected to the likes of Philips, Hewlett Packard and Microsoft. Presently available (NTSC format) PVRs will hold from 6 to 30 hours of video.

Think of it as a temporary rather than a permanent storage medium since when the drive fills up, material must be removed or replaced to make room for new material.

TiVo with the support of Philips believes PVR users will want to select specific programs from an EPG menu service and an in-built modem downloads the next day's EPG schedule every night. The user clicks their way through the menu selecting TV channel, programme by programme for recording. It is faster than programming even the best VHS machines, and when you want to watch your selections, the clicked on programme comes up instantly because there is no tape to wind or rewind to locate the recording.

Replay TV, the competitor, believes the future of PVRs is not in stand alone units (although it has a range on offer), rather they see PVR technology built into future satellite TV receivers and digital TV sets. Both start-ups offer a menu

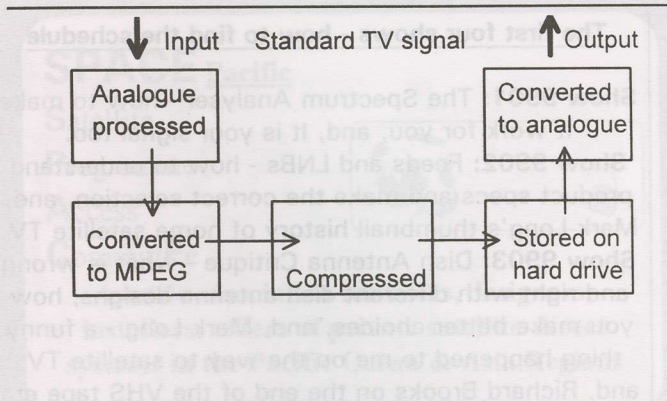

ReplayTV	TiVo
6 hrs/\$699	14 hrs/\$499
28 hrs/\$1499	30 hrs/\$999

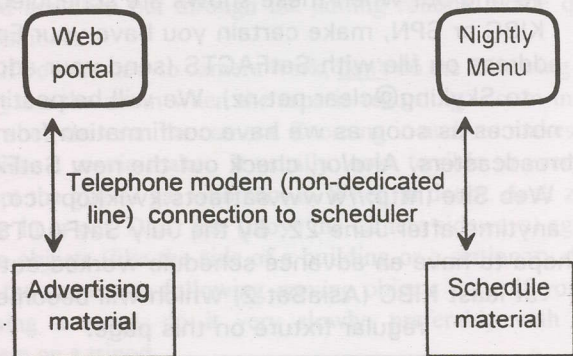

driven point and shoot IR control system that reduces to seconds the set-up routine for selecting programmes to record in your absence.

Hard drives will not wear out (as tape does), won't get clogged or dirty heads, and will present no storage problems for the recording mechanism. How does any of this affect the CATV/SMATV operator?

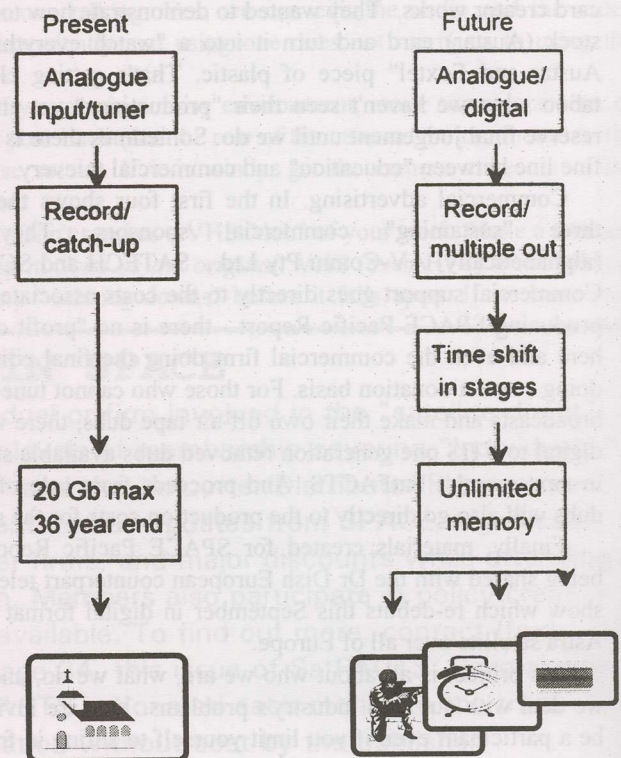

The early hardware is of limited attraction although you could take a stock (NTSC unfortunately) PVR and use it to time shift a service that is west of you by several hours to a "replay" the next day at more advantageous viewing hours. You could do this on a totally new CATV/SMATV channel, giving viewers the live broadcast where it now resides and a more comfortable viewing hour replay on a second channel.

We are but a few months away from the second plateau of PVRs. Yes, PAL format will be here soon and with them will come multiple output versions. Here the input signal will record when instructed, and you will select output one for say a two hour delayed replay and output 2 for a four hour time shifted replay. A movie service now run on one channel could become three (or more) movie services, showing the same features from a single download (input) over a series of time shifted outputs. By programming the PVR to restart a new recording sequence at midnight each day, you would have a nearly full automation hands-off multiple (cable) channel service package.

DirecTV (an American DBS operator) and Echostar (a competitor DBS operator as well as hardware producer) both are planning last quarter 1999 DBS receivers with PVR capability built-in. This is to be a consumer level device, ending forever the tangle of wire required to interface a satellite receiver to a separate recording device. By the first quarter of 2000, we would expect Asian manufacturers to be offering FTA format digital receivers with PVR capability along with stand alone PVRs. If the initial USA pricing seems quite reasonable - we believe it is for a start-up product - wait around a year to see how inexpensive PVR stand alones and attachments become. The secret of course will be the constant improvement in hard drive memory capacity at ever lowering

pricing. For the past three years, memory capacity (cache ability) has doubled every 12-14 months at the same price level (i.e. 40 Gb at today's price of 20 Gb by June-July of 2000).

PVRs may not replace VHS tape and in fact their use may be so new and different that the two don't even compete for a few years down the road. PVR technology is more likely to be to TV viewing what the Internet "browser software" has been to the development of Web sites. Before browsers, manual searches for subjects of interest was very time consuming. With browsers, enter a key word and the PC does the surfing and searching. The hard drive PVR is likely to have a similar social impact on TV watching, changing forever the way people collect around their TV sets at specific times and forcing their living schedules to conform to the TV broadcasting schedules.

You can learn more about PVRs by checking for the SPACE Pacific Report television programme number 9303 (see p. 20/21 here), or by asking your Web surfer to look for material under the heading of "Time-Shifted Television".

**DAILY:** <http://www.satfacts.kwikkopy.co.nz>

**WEEKLY:** SPACE Pacific Report on a satellite dish near you

**First of month:** Coop's Technology Digest

**15th of month:** SatFACTS Monthly

# ADI MediaMate

## Digital Satellite Receiver

**SPECIAL INTRODUCTORY PRICE** INCLUDES TAX

**ONLY \$695**

CALL FOR EXPORT \$\$\$

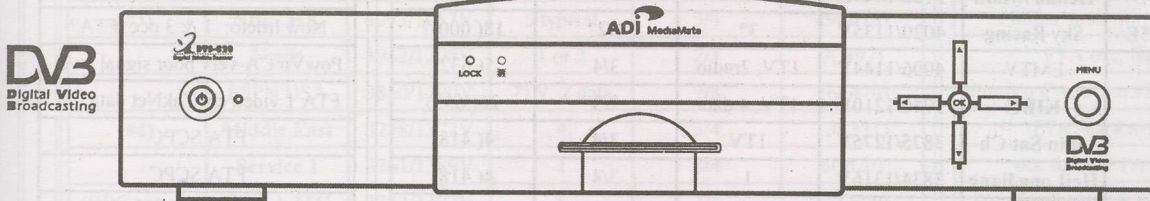

- Low Threshold Performance
- Easy to use Graphic Interface
- 2 - 32 Msymbols (FTA Power View)
- NTSC & PAL Outputs
- 22Khz / DiSeQ / 12VDC Aux
- Teletext Output in Video
- 90 - 264 VAC 47 - 63 Hz Power supply
- 27 / 36 Mhz Tuner
- PID Menu
- RS232 Computer Control & Software Download

Also Available 1.8m & 2.4m Solid Steel Dishes & MTI Dual Pol C Band LNBFs

**Pacific Digital Systems Pty Ltd Ph. 61 2 8765 0270 Fax. 61 2 8765 0275**

**EXCLUSIVE AUSTRALIAN, NEW ZEALAND, PACIFIC ISLANDS DISTRIBUTOR**

# SatFACTS Pacific/Asian MPEG-2 Digital Watch: 15 June 1999

BIRD	Service	RF/IF & Polarity	# Program Channels	FEC	Msym
I703/57E	Sky News	4143/1007R	1	3/4	5(.632)
	CNBC	4018/1132L	1	3/4	6(.000)
I704/66E	TV5. Adult 21	4055/1095R	4	3/4	27(.500)
	Sky News +	3805/1345R	4	3/4	22(.520)
PAS4/68.5E	Nickelodeon +	4147/1003H	1 reported	1/2	24(.000)
	BBC	3743/1407H	5	3/4	21(.800)
	CCTV	3716/1434H	up to 6	3/4	19(.850)
Ap2/76E	HMark/Kermt	3720/1430H	4	5/6	29(.270)
	TVB-8 +	3849/1301H	4	3/4	13(.238)
	Disney	3880/1270H	3	5/6	28(.125)
	AXN	3920/1230H	up to 8	7/8	28(.340)
Them3/78.5E	ITC	3569/1581H	1	3/4	10(.200)
	MRTV	3666/1484H	1	2/3	4(.442)
	UTV	3920/1230H	6	3/4	26(.662)
	UTV/MCOT	3880/1270H	8	3/4	27(.500)
	Mahar./DD1	3600/1550H	up to 8	3/4	26(.662)
	Myanmar TV	3666/1484H	1	3/4	4(.442)
	TV Maldives	3412/1738V	1	1/2	6(.312)
	Thai Global +	3425/1725V	up to 7	2/3	27(.500)
As2/100.5E	Euro Bouquet	4000/1150H	6TV,12r	3/4	28(.125)
	Hubei/HBTV	3854/1296H	1	3/4	4(.418)
	Hunan/SRTC	3847/1303H	1	3/4	4(.418)
	Guan./GDTV	3840/1310H	1	3/4	4(.418)
	Inn Mongolia	3828/1322H	2	3/4	4(.418)
	Saudi Arabia	3811/1339H	1	3/4	3(.905)
	APTN A-O	3799/1351H	1	3/4	5(.631)
	WTN Jer/Lon	3790/1360H	1	3/4	5(.631)
	Reuters/Singap	3775/1375H	1	3/4	5(.631)
	(off air???) Reuters M-E	3770/1380H	1	3/4	5(.632)
	WorldNet	3764/1386H	1 + 20 radio	3/4	6(.100)
	Liaoning/Svc2	3734/1416H	1	3/4	4(.418)
	Jiangxi/JXTV	3727/1423H	1	3/4	4(.418)
	Fujian/SETV	3720/1430H	1	3/4	4(.418)
	Hubei TV	3713/1437H	1	3/4	4(.418)
	Henan /Main	3706/1444H	1	3/4	4(.418)
	As2/100.5E	Sky Racing	4020/1135V	3?	1/2?
EMTV		4006/1144V	1TV, 2radio	3/4	5(.632)
KIBC		3940/1210V	1TV, 4 data	2/3	26(.655)
Jilin Sat Ch		3875/1275V	1TV	3/4	4(.418)
HeiLongJiang		3834/1316V	1	3/4	4(.418)
JSTV		3827/1323V	1	3/4	4(.418)
Anhui TV		3820/1330V	1	3/4	4(.418)
Shaanxi/QQQ		3813/1337V	1	3/4	4(.418)
Guang GXTV		3806/1344V	1	3/4	4(.418)
Fashion TV		3796/1354V	1	3/4	2(.533)
Feeds		3785/1365V	1	3/4	5(.632)

Receivers and Errata
NDS encrypted: often FTA
Feeds-FTA SCPC
FTA (Adult 21 off air???)
Sky News 24 hr, sport, feeds FTA?
Ws testing FTA - still active???
FTA: 2 audio channels?
FTA
PowVu typ CA
PowerVu CA
PowVu CA
Tests, promos, some FTA
FTA
FTA: difficult to load
Irdeto CA
Irdeto CA
FTA (Indian, Skai-TV)
FTA - may be only test
FTA (seen Australia)
FTA
FTA (TV5 teletext)
FTA SCPC, teletext
FTA SCPC, teletext
FTA SCPC
FTA - #1 Chinese, #2 Mongolian
FTA SCPC - "Ch. 1"
FTA SCPC
Mostly CA SCPC, some FTA
Some FTA SCPC
Some FTA SCPC
FTA, multiple radio channels
FTA SCPC
FTA SCPC: teletext
FTA SCPC
FTA SCPC
FTA SCPC
Now Irdeto: 1 & 3 occ. FTA?
PowVu CA-very poor signal level
FTA 1 video ch; ZakNet data CA
FTA SCPC
FTA SCPC
FTA SCPC
FTA SCPC
FTA SCPC
(remains) FTA-difficult to load
Was Eastern TV - now SCPC feeds

BIRD	Service	RF/IF & Polarity	# Program Channels	FEC	Msym
(As1-cont)	Myawady TV	3766/1384V	1	7/8	5(.080)
As3S/105.5E	Arirang TV	3755/1395V	1	7/8	4(.418)
	Star TV	3780/1370V	17TV?	3/4	28(.100)
	Star TV	3860/1290V	14 TV	3/4	27(.500)
	Star TV	3880/1270H	12TV	7/8	26(.850)
	CNNI	3960/1190H	4(+?) TV	3/4	26(.000)
	Star TV	4000/1150H	7TV	7/8	26(.850)
Cak1/107.1E	Indovision S-band	2.536, (.566, .596, 2.626)	38+	5/6	20(.000)
Sinoat 1/110E	Shanghai	4106/1044V	1	2/3	4(.443)
C2M/113E	TV Indosiar	4073/1077V	1	3/4	6(.500)
	Feeds	3995/1155Hz	1	3/4	6(.620)
	Mega TV	3780/1370V	5?	3/4	27(.500)
	C Net Taiwan	3760/1390H	11TV, 10 r	5/6	21(.091)
	RCTI	3475/1675H	1	3/4	8(.000)
JcSat3/128E	NK-J	3990/1160V	1	1/2	6(.100)
LMI API/130	THT (TNT)	3725/1425L	1	3/4	6(.108)
API/138E	Taiwan Bqt	3800/1350H	up to 8	3/4	26(.697)
	Laos Nat. TV	3924/1226V	1	3/4	2(.522)
	CNNI	3980/1170V	4	3/4	26(.000)
Optus B3/156	Aurora	12.595, 720V	17+, 21+ rad.	3/4	30(.000)
	Aurora	12.407, 532V	17+, 21+ rad.	2/3	30(.000)
	Austar/Foxtel	12.438(.564, .626, .688)	45+TV, 12 radio	3/4	29(.473)
Optus B1/160	Sky NZ	12.391(.418)V	19+TV	3/4	22(.500)
PAS-8/166E	TARBS	12.524H	10(+TV)	3/4	28(.062)
	NHK Joho	4065/1085H	5 TV, 1 radio	3/4	26(.470)
	Cal Bqt/PAS8	3940/1210H	4 or 5 TV	7/8	27(.690)
	CNN	3780/1370H	3 up to 5	3/4	25(.000)
	Test bouquet	3740/1410H	4 or 5 TV	7/8	27(.690)
PAS-2/ 169E	GWN Perth	12.265V	6TV, 7 radio	1/2	16(.200)
	Telstra Bend.	12.300V	2	1/2	21(.997)
	ABC Interchange	12.629, (.638, .646)V	1 TV each	3/4	6(.980)
(off air?)	Mediasat	12.655V	1TV	1/2 & 3/4	6(.610)
(#2)	HK PowVu	4148/1002V	up to 8	2/3	24(.430)
(#3)	NBC HK	4093/1057V	5 typical	3/4	29(.473)
	Feeds	3942/1208V	1 or 2	2/3	7(.497)
	ESPN USA	3860/1290V	7TV, 2 data	7/8	26(.470)
(#4)	Middle East	3778/1372V	4	3/4	13(.331)
	Service 1	3761/1389V	1	3/4	6(.620)
(BBC temp)	BBC + TFC	3743/1407V	5	3/4	21(.800)
(#5)	CCTVPowVu	3716/1434V	5 typical	3/4	19(.850)
	TCS-Singap.	4183/967H	2	1/2	6(.620)
	NTV Japan	4174/976H	1	3/4	5(.632)
	Feeds	4138/1012H	1	3/4	6(.620)
(#7)	NHK Joho	4035/1115H	5TV, 1 radio	3/4	26(.470)
	CNNI HK	3996/1154H	1TV	3/4	9(.998)
	Feeds	3967/1183H	1+	2/3	6(.618)
	7th Day Adv.	3957/1193H	1, 14 audio	3/4	7(.000)
	PAS-2 feeds	3939/1211H	2 (NTSC)	2/3	6(.620/7.498)
(#8)	Cal PowVu	3901/1249H	up to 8	3/4	30(.800)

Receivers & Errata
FTA SCPC - difficult
FTA SCPC - strong!
NDS CA (Pace DVS211)
NDS CA (Pace DVS211)
NDS CA (Pace DVS211)
PowerVu-some FTA?
NDS CA (Pace DVS211)
RCA/Thomsom IRD. Now more dependable operation
FTA SCPC-difficult to load
FTA SCPC, maynot be permanent
SCPC FTA. test card
unknown encryption format
all TV now CA but subs available
FTA SCPC
Unknown/CA?
typ. 0500-2100UTC. FTA Russian
FTA MCPC
FTA SCPC
CNN FTA
CA. \$50 smart card required
CA. \$50 smart card required
DGT400 CA except FTA
TVSN and radio
NDS CA. 12.391 primary
Test (some FTA) of ethnic service
1CA (D9234), 4 FTA
mixed CA + FTA (EWTN)
PowVu. temp FTA
mixed CA-FTA/duplicates 3940
PowVu CA (D9234)
PowVu typ. CA (D9223 only)
format PowVu, nominally FTA. except 0000-0400UTC wkdays
FTA, occassional service. feeds
PowVu, mostly CA. some FTA
Philips mux format FTA
FTA occ. feeds
PowVu CA. avoid #8.9 w/9223!
FTA -hard to load
occ feeds, FTA SCPC
PowVu; CA and FTA (BBC#3)
FTA (# pgm chs varies)
PowVu FTA/news ch coming
FTA SCPC feeds (occassional)
FTA SCPC
1 CA (D9234), 4 FTA to 31/05/99
FTA - occasional feeds
FTA - World Cup Cricket
1900-2030UTC. not daily
FTA (NBA . shuttle-typ NTSC)
Some CA. some FTA ( NTSC )

## SatFACTS Digital Watch: Supplemental Reference Data / June 1999

PAS-2/169E	Disney	3804/1346H	3	5/6	21(.093)
	Discovery Sing	3776/1374H	8	3/4	21(.093)
	<b>Satcom 1-6</b>	3743/1407H	5	7/8	19(.465)
1702/177E	AFRTS	4177/973L	8TV, 12r.+	3/4	26(.694)
inactive?	<b>Thai Bouquet</b>	12.650H	up to 3 TV	1/2	17(.800)
1701/180E	TVNZ Gennet	4195/955R	1 (CA)	3/4	5(.632)
		4186/964R	BBC/Gennet	3/4	5(.632)
		4178/972R	1 (CA)	3/4	5(.632)
		4170/980R	APT-N-Tokyo	3/4	5(.632)
	AFRTS Pac.	4175/975L	3 radio	2/3	3(.679)
(#9)	<b>RFO-Canal+</b>	4095/1055L	7TV, 5+ radio	3/4	27(.500)
	<b>SPN Nauru</b>	4081/1069R	1	3/4	4(.730)
	NZ Prime TV	4024/1126L	1	2/3	6(.876)
	<b>RFO Polycast</b>	3858/1292L	1	3/4	4(.566)
	TVNZ TL	3854/1293R	1	3/4	5(.632)
	TVNZ	3856/1294R	1	3/4	5(.632)
	TVNZ	3846/1304R	1	3/4	5(.632)
	10 Australia	3765/1385R	6	7/8	29(.900)

PowVu (D9234) CA
PowVu (D9234) CA
recently Middle East (4 chs)
PowVu (D9234) CA
FTA, replaced Space TV
DMV/NTL CA, all channels occ. use. <b>FTA irregular</b> around special event coverage
PowVu, CA audio (3 chs.)
Canal + (2) CA, <b>rest FTA</b>
FTA SCPC: weak signal
PowVu CA; network feeds
East hemi beam to Tahiti
SCPC <b>mixed FTA</b> , CA feeds
SCPC <b>mixed FTA</b> , CA feeds
SCPC <b>mixed FTA</b> , CA feeds
PowVu CA: <b>#5,6 occ FTA</b>

**Bouquets:** MCPC (multiple [program] channels per carrier) MPEG-2 content frequently changes. Primary FTA (free to air) MCPC bouquets are as follows: 1) **European Bouquet:** (1) **Deutsche Welle**, (2) **MCM**, (3) **RAI International**, (4) **RTVE** (Spain), (5) **TV5 Paris** + up to 17 radio (some stereo) - see p. 2; 2) **Hong Kong PowVu:** (5) **Ad Hoc NTSC feeds**, (6) **Ad Hoc PAL feeds:** (3) **NBC HK** (Hong Kong): (1) **CNBC Asial**, (2) **CNBC Australia**, (3) **National Geographic [English]**, (4) **CNBC India**, (5) **National Geographic [subtitled Taiwan]**, (6) **Occ feeds**, (7) **CNBC test card-feeds:** (4) **Middle East** [testing: (1) **Antenne 1**, (2) **Lebanon LBC**, (3) **ART Australia**, (4) **RAI Australia**]; (5) **CCTV PowVu:** (1) **CCTV4**, (2) **CCTV3**, (3) **CCTV 9**, (4) **test bar**, (5) **CCTV1:** (7) **NHK JoHo:** (1) **NTSC Japanese**, (2) **NTSC English**, (3) **PAL Japanese**, (4) **PAL English**, (5) **NHK Radio**, (6) **NHK Premium**; (8) **Cal PowVu:** (1) **CMT [NTSC]** (CA 01/07), (2) **Ad-hoc/CBS [NTSC]**, (3) **BBC[NTSC]**, (4) **EWTN** + Global Catholic Radio, (5) **Ad hoc feeds**, (6) **Bloomberg Financial [NTSC]**, (7) **Golf Channel [NTSC]**, (8) **Feeds:** (9) **RFO-Canal+:** (1) **Canal+ [Polynesia]**, (2) **Canal+ [New Caledonia]**, (3) **test**, (4) **test**, (7) **TOM1**, (10) **TOM2**, (13) **TOM3** + radio on 5.6,8,9,11,12,14,15.

### MPEG-2 DVB Receivers: (Data believed accurate; we assume no responsibility for correctness!)

**ADI MediaMate.** FTA, NTSC-PAL outputs. (Pacific Digital Sys. Pty Ltd, tel 61-2-8765-0270)  
**AV-COMM R3100.** FTA, excellent sensitivity (reviewed SF May 1998). Av-Comm Pty Ltd., tel 61-2-9949-7417  
**Grundig DTR1100.** Mfg by Panasat S. Africa, similar to Panasat 630; out of production, Irdeto capable (see AV-Comm. above)  
**Hyundai-TV/Com.** HSS-100B/G (Pacific) and HSS-100C (China) FTA. Versions 2.25/2.26 good performers. 3.11 later offered and those with Nokia tuners good performers. Version 5.0 not so good. SATECH ([V2.26] 61-3-9553-3399), Skandia ([V3.11] 61-3-9819-2466).  
**Hyundai HSS700.** FTA, PowerVu, search, SCPC/MCPC. (Kristal Eletronics 61-7-4788-8906) [review March99]  
**MediaStar D7.** FTA, preloaded with known services, exc. software (review SF July 1998). MediaStar Comm. Int. (61-2-9618-5777)  
**Nokia "d-box" (V1.7X).** European, FTA, typically German menu, capable of "Dr. Overflow" Internet updates. Caution on this one!  
**Nokia 2000S (Asia/Pacific).** Released Oct. 1998; equipped with CAM/PCMCIA slot, capable of Irdeto, others (factory will NOT supply CAMs at this time); no Asia-Pacific sources known at this time (but readily available through European sources); review 11/98.  
**Nokia 9200/9500/9600/9800.** FTA, factory software does PowVu poorly, but has significant Internet software support. Ultimate play-around hobby machine but not consumer friendly. Original V1.63 had unique ability to search entire satellite to locate and list all SCPC/MCPC services; latest (V5.X software) versions compatible with Dr. Overflow (V8.X) software from Internet. CI (common interface) versions available in Europe, do not presently allow Irdeto however. No Pacific/Asia support; help from Av-Comm (61-2-9949-7417), and software from www.BAKKERELECTRONICS.COM. 9800S single chip released mid-May 1999.  
**PACE DVS-211.** NDS CA only (no FTA); , Indovision, Star TV Asia. (Viva, Star News to Aust - Solution 42 61-2-9820-5962)  
**PACE DGT400.** Original Galaxy (now Foxtel Sat/Austar) IRD, Irdeto, FTA with difficulty. (Foxtel Australia 1300-360818).  
**PACE DVR500.** Original NBC affiliate IRD; FTA or Irdeto (w/CAM). Similar to DGT400, more reliable. No sources.  
**PACE "World Box."** (DSR-620) Created for NDS non-DVB compliant MPEG-2, including Sky NZ. Info. ++49-211-526-9833.  
**Panasat 520/630/635.** MCPC FTA, Irdeto capable. Out of production; spares from UEC (fax ++27-31-593-370.)  
**Panasonic TU-DS10.** FTA, Irdeto CA. (see SF Aug. 1998). Aurora, (Evcom 61-2-9316-5055).  
**Phoenix 111 & 222.** FTA, PowVu. Exceptional graphics, ease of use. (SATECH 61-3-9553-3399) (111 review May 1999)  
**Phoenix 333.** FTA MPEG-2, analogue, positioner. Detailed review SF Nov. 1998. (SATECH 61-3-9553-3399).  
**PowerCom.** FTA, PowVu, exc. sensitivity. (NetSat 61-2-9687-9903)  
**PowerVu /PowVu D9223.** 9225, 9234). Non DVB compliant proprietary format capable MPEG-2 FTA with optional software. 9234 sold for GWN and NHK Joho PAS-2, EMTV As2, CA access; others for various CA services. (Scientific Atlanta 61-2-9452-3388)  
**Praxis DigiMaster 9600 MKII/9800AD.** FTA, PowVu + analogue.; (no longer supported in Pacific), was Skyvision - see below)  
**Praxis 9800 ADP.** FTA, PowVu, analogue, positioner. Review December 1998. (no longer supported in Pacific, see Skyvision below)  
**Prosat 2102S.** FTA, NTSC + PAL, SCART + RCA. (Sciteq 61-8-9306-3737)  
**SatCruiser DSR-101.** FTA, PowVu, NTSC + PAL. (Skyvision Australia 61-2-6292-5850; Telsat 64-6-356-2749)  
**SatCruiser DSR-201P.** FTA, NTSC & PAL digital, analogue, positioner. (Skyvision Australia - see above)  
**SK888.** (aka DigiSkan from Sun Moon Star). FTA MCPC, Irdeto CAM capable. (Skandia 61-3-9819-2466)  
**UEC 642.** FTA, Irdeto built-in, for Aurora + Optus DTH. ("Mondec" rack mount industrial version) (Nationwide 61-7-3252-2947)  
**UEC 660.** Aust Sky Ch. (1 version), Foxtel Aust. (2nd version); (now available for retail users at Nationwide 61-7-3252-2947)  
**YURI HSS-100C.** FTA, rebadged Hyundai V.2.27 software custom to Australia (Nationwide 61-7-3252-2947)

# SatFACTS Pacific/Asian FTA ANALOGUE Watch: 15 June 1999

Copyright 1999: SatFACTS, PO Box 330, Mangonui, Far North, New Zealand (FAX 64-9-406-1083)

BIRD / Location	RF/IF & Polarity	Service	Errata	
<b>I703/57E</b>	3760/1390R	Sun TV		
	3808/1342R	Udaya TV		
	3886/1264R	Surya TV		
	3980/1170R	AsiaNet		
	4052/1098R	WorldNet	VOA subcar.	
	4178/972L	MTA Inter.		
<b>I604/602/60E</b>	4166/984	feeds		
<b>I704/66E</b>	3765/1385R	Tests		
	4015/1135L	Mongolia	(SECAM)	
<b>PAS4/68.5E</b>	3743/1407V	RTPi		
	3864/1286V	BBC World		
	3907/1243H	Sony TV	Hindi	
	4034/1116V	Doordan		
	4087/1063H	CNNI		
	4110/1040H	TNT/Cartoon		
	4113/1037V	Series Ch.		
	4182/968H	MTV		
	<b>PAS7/68.5E</b>	3470/1680V	Test Signal	
	<b>Ap2R/76E</b>	3745/1405V	Vasta Music	P5 NSW
		3760/1390H	TEN tests	
	<b>Thaic3/78E</b>	3871/1279H	TVT	
3760/1390V		Army TV		
3690/1460V		MRTV		
3685/1465H		Mynamar		
3616/1534V		ATN		
3576/1574V		ATN Bangla	Bengali	
3554/1596V		RAJ Plus		
3536/1614V		Punjabi TV	unreliable	
3514/1636V		Falak TV		
3489/1661H		Vasta Music	tests	
	3465/1685V	RAJ-TV		
<b>Exp. 6/80E</b>	3672/1478L	TK Rossija	(north only)	
<b>InSat2E/83E</b>	3696/1454V	Teluga		
	3808/1342V	AIR-Tamil		
	3849/1301V	DDI National		
	3929/1221V	DD2 Metro	P5 Aust.	
	3971/1179V	DD8	Andre Prades	
	3998/1152V	sport feeds		
	4014/1136V	feeds		
	4081/1069	DD7	West Bengal	
	<b>ChiStr1/87.5</b>	3875/1275H	occ. feeds	P4 NSW Ntsc
	<b>ST1/88E</b>	3550/1600V	test card	
3582/1568V		Nila TV		
<b>CIS S6/90E</b>	3675/1475R	RTR1	P3 NSW	
	3875/1275R	Orbita I		
	3916/1234R	RTR II		
	3935/1215R	Orbita II		

<b>MeSat-1/91.5E</b>	3710/1440H	VTV 1,2, 4	
	3880/1270H	RTM-1	
<b>Insat2B/93.5E</b>	4165/985H	India Metro	Aust on 3.7m
	4125/1025V	Ind. National	Aust on 3.7m
	4070/1080H	India DD9	
	4080/1070V	DD7 (Tamil)	
	3970/1180V	DD9 (kan.)	
	3882/1268V	India DD1	
	3840/1310V	India DD	
	3762/1388V	India DD4	
<b>CIS-S20/96.5E</b>	3675/1475R	ORT	(this satellite
	3825/1325R	Madagascar +	may be out
	3875/1275R	Test Card	of service)
<b>AsSat2/100.5E</b>	3642/1508H	ERTU Egypt	
	3660/1490V	Test Card	
	3680/1470H	Feeds/Iran	
	3860/1290V	Feeds #	
	3885/1265H	WorldNet	VOA Subcar.
	3960/1190H	CCTV4	
	3980/1170V	RTPi	Radio Subcar.
<b>CIS S21/103E</b>	3675/1475R	RTR	
	3875/1275R	Vrk.Apt	
<b>AsSat3S/105.5</b>	3760/1390H	CETV	
	(temp FTA)	3800/1350H	Star Sports NTSC
	(temp FTA)	3840/1310H	Channel [V] NTSC
	(temp FTA)	3920/1230H	Phoenix Chin. NTSC
	3940/1210V	Zee India	
	3980/1170V	Zee TV	
	4060/1090V	Zee Cinema	(starcrypt)
	4100/1050V	PTV2/World	0900-2400 PST
	4120/1030V	CCTV4	NTSC
<b>PalB2R/108E</b>	4000/1150H	TVRI	
<b>PalC2/113E</b>	4183/967V	TPI/TVRI	
	4160/990H	(France) TV5	poor audio
	4140/1010V	Brunei. feeds	
	4120/1030H	MTV Asia	
	4080/1070H	Herbalife	2100HK/NTSC
	4040/1110H	CNBC	
	4020/1130V	ANteve	(left air?)
	3970/1180V	CNNI	(was 3980)
	3900/1250V	Malaysia TV3	CA and FTA
	3880/1270H	Aust. ATN7	
	3840/1310H	TVRI	temporary?
	3765/1385H	NBC, CNBC	Feeds, Herbalif
	3742/1408V	RCTI	English subcar
<b>AsSat-G/122E</b>	3675/1475L	bird moving	to 77.5E
<b>ChinSat 6/125</b>	4085/1065V	feeds	is it really here?
<b>G'zont29/130E</b>	3675/1475	NTV (+8hrs)	off 1400 UTC
<b>Ap1A/134E</b>	3820/1330H	CETV SD	

53.2	55	57	66	68.8	76	78.5	80	87.5	88	91.5	93.5	100.4	103	105.5	107.1	108	110.5	1.103	120	(122)
S27	2DT	1703	1704	PAS4 PAS7	Ap2	Th3	Ex2	Cs1	St1	Me-1	In2B	As2	S21	As3S	Ck1	B2R	Ss1	C2	Th1/ 2	As1
C	C	C	C	C	C	C	C	C	C	C,Ku	C	C,Ku	C	C,Ku	"S"	C	C,Ku	C,Ku	C	C

128	130	134	138	(139)	140	145	146	148	(151)	152	156	160		166.5	169	174	177	180	177	148
Jc3	ANI	Ap1a	Ap1	Or3s	S7	S16	Ag2	Me2	C1	A3	B3	B1		PAS8	PAS2	1801	1702	1701	IF3	Es4
C,Ku	C	C	C	C,Ku	C	C	C,Ku	C,Ku	C	Ku	Ku	Ku		C,Ku	C,Ku	C	C,Ku	C	C,Ku	Ku

Ap1A/134E	3900/1250V	CETV2	
	3980/1170V	CETV1	
Ap1/138E	4160/990H	CCTV7	
S7/140E	3675/1475R	Test Card	mod. inclined
S16/145E	3675/1475R	ORT	high inclined
	3875/1275R	Feeds, tests	high inclined
Ag2/146E	3787/1363H	GMA	poor s. eqtor
Me2/148E	4080/1070H	test card	occ. use
C1/150E	4160/990H	TPI	occ. use
PAS8/166.5	3865/1285H	Napa test card	not full time
PAS2/169E	3940/1240V	CNN1	1/2 Tr format
1802/174E	4166/984R	Feeds	
	4177/973R	Feeds	
1702/177E	4166/984R	Feeds	KBS Korea
	4187/963R	Feeds	Feeds
1701/180E	3810/1340R	Feeds	
	3841/1309L	RFO	East beam
	3845/1305R	Feeds	inc. USA
	3930/1220R	USA Feeds	Typ. encrypt.
	3975/1175R	Feeds	
	4060/1090L	Feeds	
	4130/1020L	Feeds	

### Major Changes - Next 30 Days

CNN1 analogue PAS-2, originally scheduled to shut down May 31, now postponed to June 15th - subject to resolving PAS-8 digital uplink problem. CNN1 digital in new bouquet, As3S, scheduled June 15th to CA. "Business is booming" in major Australian markets for Indian TV systems - as low as \$900, as high as \$1,500 installed, for analogue systems. Driving this is combination of As3S Indian/Pakistani channels plus newly available InSat 2E services which although at low look angles along Australian east coast are very desirable because of quantity and quality of programming.

### Optus B3 at 156E / Ku only

12.720/1420V	Aurora MPEG	Irdeto CA IRD	see p.15.18 May
12.688/1388H	Austar MPEG	Irdeto CA IRD	list p.31
12.626/1326H	Austar MPEG	Irdeto CA IRD	list p.31
12.594/1296V	Aurora MPEG	Irdeto RABS	see p.15.18 May
12.564/1263H	Austar MPEG	Irdeto CA IRD	list p.31
12.532/1232V	Aurora MPEG	Irdeto RABS	see p.15.18 May
12.438/1138H	Austar MPEG	Irdeto CA IRD	list p.31
12.407/1107V	Aurora MPEG	Irdeto RABS	see p.15.18 May

### Optus B1 at 160E / Ku only

12.730/1430H	RHEF, NZ feeds	typ FTA anal.	occ. use
12.576/1276H	ABC Radio	digital	
12.570/1270V	OmniCast		FM/FM
12.541/1241H	Herbalife	Mon, Wed	1000-1100UTC
12546/1246V	Sky NZ	NDS-MPEG	& 12.518(CA)
12.520/1220H	Net 9 feeds	typ. BMAC	
12.518/1218V	Sky NZ	NDS MPEG	& 12.546 (CA)
12.482/1182V	Net 10 feeds	typ. E-PAL	
12.480/1180H	Net 9 feeds	typ E-PAL	
12.455/1155V	Net 10 feeds	typ. analogue	
12.418/1118V	Sky NZ	NDS-MPEG	& 12.391 (CA)
12.391/1091V	Sky NZ	NDS MPEG	& 12.418 (CA)

### Oddball Formats

PAS-4/68.8	3785/1365V	Discov. India	BMAC
PAS-4/68.8	3860/1290H	ESPN Indian	BMAC
Ap2/76E	3960/1190H	HBO Asia	GI Digiciph2
C2/113E	3930/1220H	Fil. Peo. Net	GI 1.5 MPEG
PAS2/169E	3836/1314H	ABS/CBN	GI 1.5 MPEG
PAS2/169E	3989/1161V	Fox/Prime	Sa1.5MPEG

### UEC 642/660 Decoder "Hit" Override

**Problem: After receiving HIT, IRD only receives 7 channels (12.438 bouquet). (1) Go to menu, (2) Go to advanced options-OK, (3) Go to Change dish installation -OK, (4) Enter 9949, (5) Tune & Rescan -OK.**

### June Alert

**There is no significant "new" satellite activity scheduled for this month. However, Arirang TV testing on As3S SCPC (3755/1395 - 4.418, 3/4) should be monitored. New high power Ku NSS-K to 95E could be an eye opener worth checking.**

### Upcoming Satellite Launches

NSS-K to 95E - 30 HP Ku, "early June"  
 Chinasat 8 to 115.5E - "June-Aug." 32C, 16Ku  
 Telekom 1 to 108E - July 2, replace B2R  
 co-launched with  
 AsiaStar to 105E (1452-1492 L-band radio) - July 2  
 KoreaSat 3 to 116E -12-18 August, 16 Ku to replace Ks1  
 Express A1 to 80E - August, 12 C, 5 Ku



# WITH THE OBSERVERS

## AT PRESS DEADLINE

THT on Gorizont at 130E is rapidly developing a schedule which goes far beyond the "TNT in Russian" format initially launched. USA sporting events, ESPN segments, movies, pop music and more. Francis Kosmalski suggests you will find this inclined orbit satellite crossing the equator around 1600 UTC. Question: Is this FTA digital in SECAM? It appears to be.

AsiaSat 2/100.5E: Sky Racing (channel 1), now Irdeto rather than NDS, frequently in clear while sorting out subscriber addressing problems (4010/1030Vt). KIBC has not left this satellite; try reloading parameters (3940/1210Vt, Msym 26.655, FEC 2/3). Occasional feeds on 3786/1364Vt (old Eastern TV channel?) at Msym 5.632 and FEC 3/4.

AsiaSat G/122E: Reported moving west, announced new location to be 77.5E but very limited use likely at this location.

AsiaSat 3S/105.5E: Arirang TV (Korea FTA) began test transmissions June 7, will launch full daily 24 hour schedule August 12 (3755/1395Vt, Msym 4.418, FEC 7/8). CNNI bouquet, parallel to ApStar 1 package, now on 3960/1190Hz (Msym 26.000, FEC 3/4). Four channels (some report six), CNNI (#1) and news feeds (#3) FTA, Cartoons/TNT (#2) and Cartoons/TNT Taiwan (#4) CA; CNNI scheduled to be CA June 15. Video on CNNI is "soft" (**Jepson, NZ**).

Express 6/80E: Tests on 4080/1070RHC Msym 8.678, FEC 1/2 (probably not visible south of equator).

JcSat3/128E: "Service still operating that loads on Nokia V1.63 as NK-J (3990/1160Vt, Msym 6.100, FEC 1/2). Also, GAORA loads at 4000/1150Vt (Msym 6.111, FEC 3/4) - both appear to be CA. Does anyone else load these?" (**Kosmalski, NZ**)

Gorizont 29/130E: "Is THT extending hours? Signed off 2220UTC (3725/1425LHC) Sunday June 6. Strangely, while my Nokia V.1.63 will load, reception is more out than in while SA D9223 with FTA software upgrade holds image clean and stable - but often only after agonising 5 minutes to load - BER peaks 7.2E4, similar to California Bouquet here" (**Kosmalski, NZ**). Note: <http://www.THT.ru> is schedule - in Russian!

InSat 2E/83E: Occ. feeds 3564/1586Vt. AIR transmissions 3808/1342Vt are in Tamil language. "P5 services DD2/Metro (3930/1220Vt), sporting feeds (3998/1152Vt); P4 DD1 Metro (3844/1306Vt), DD8 (3971/1179Vt), DD7 Tamil 3810/1340Vt; P3 DD7 Bangladesh (4081/1069Vt; **D. Leach**, NSW on 4m). 3849/1301Vt very strong into Europe, also into WA (**Zapara**). 3696/1454Vt in Teluga (Zapara, WA).

Intelsat 701/180E: RFO Polycast operating 3858/1291LHC, SE beam, with Msym 4.566, FEC 3/4.

Palapa C1/ ex150.5E: Bird seems to be free wheeling, moving past 151E and now they admit it is not usable, being allowed to drift.

Palapa C2/113E: "Anyone else notice that audio quality (noise level) of CNNI (3970/1180Vt) suddenly got worse



Gradual development of Star TV Asia bouquets will continue over the remainder of the year on As3S with specific service groups defined by geographic location and class of service; above, authorised cable/SMATV to (some) Pacific Islands.

week of May 20?" (**Colin Frost, Qld**). "CNNI audio here around June 1 suddenly came clear for first time ever" (**Kosmalski, NZ**). Anteve MPEG-2 is gone (again) from 4193/957Vt. MCM Asia has left 3800/1350Hz (again). 3995/1155Hz (Msym 6.620, FEC 3/4) FTA test card with 4 different loading audio channels (**McLeod, NZ**). "What have they done to the audio on TV5 (France)? The video remains P5 (analogue on 4160/990Hz) but the sound portion hisses and sputters while the subcarrier radio (RFI) is fine" (**Kosmalski, NZ**).

Optus B1/160E: Herbalife now 12.541Hz, English audio 7.356 + Japanese 7.38, 1000-1100UTC Monday, Wednesday. ABC SE B-MAC has shutdown on 12.644Vt; SBS SE same on 12.670Vt. Sky (racing) Channel has shut down B-MAC service on 12.594Vt. 7 Central has shut down on 12.677Hz B-MAC.

Optus B3/156E: Massive signal level swings on Aurora Vt channels, as much as 10dB on 11m dish (Papua New Guinea).

Optus C1: Latest word is Optus has abandoned plans to include C-band for lease to Asia, will be Ku-only and not launch before 2001. They had intended to include C but point it north and lease out to other countries.

**WITH THE OBSERVERS**: Reports of new programmers, changes in established programming sources are encouraged from readers throughout the Pacific and Asian regions. Information shared here is an important tool in our ever expanding satellite TV universe. Photos of yourself, your equipment or off-air photos taken from your TV screen are welcomed. TV screen photos: If PAL or SECAM, set camera to f3.5-f5 at 1/15th second with ASA 100 film; for NTSC, change shutter speed to 1/30th. Use no flash, set camera on tripod or hold steady. Alternately submit any VHS speed, format reception directly to SatFACTS and we will photograph for you. Deadline for July15th issue: July 5 by mail (use form appearing page 34), or 5PM NZT July 6th if by fax to 64-9-406-1083 or Email [skyking@clear.net.nz](mailto:skyking@clear.net.nz).

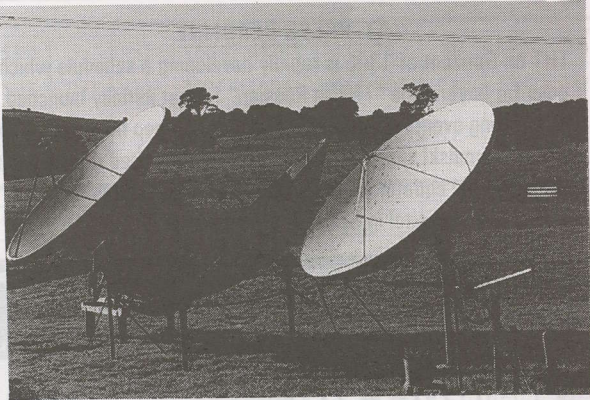

Part of the dish farm at Waipu Cable TV (NZ). 4-dish field covers PAS2/8, I1701, search and PAS-2 Ku. Note metal arrow and UHF antenna below dish on As2. UHF aerial backhauls through Videosender transmitter the BER readings out of D9223 to dish location 300+ metres from cable headend; arrow indicates wind direction on hill high above sheltered headend!

Orion 3/200 miles up: Satellite has been written off following second stage burn launch mishap. No word on replacement (I39E).

PAS2/169E: MTA International (Muslim TV) in California Bouquet was 7-day test only at this stage. Maharishi Open University/Telstra test card now gone from 12.664Vt. Herbalife has left 12.354Vt. In California Bouquet, Discovery Channel (Animal Planet) CA is replaced with PAS-Napa test card and occasional feeds. Delay in turning off CNNI analogue

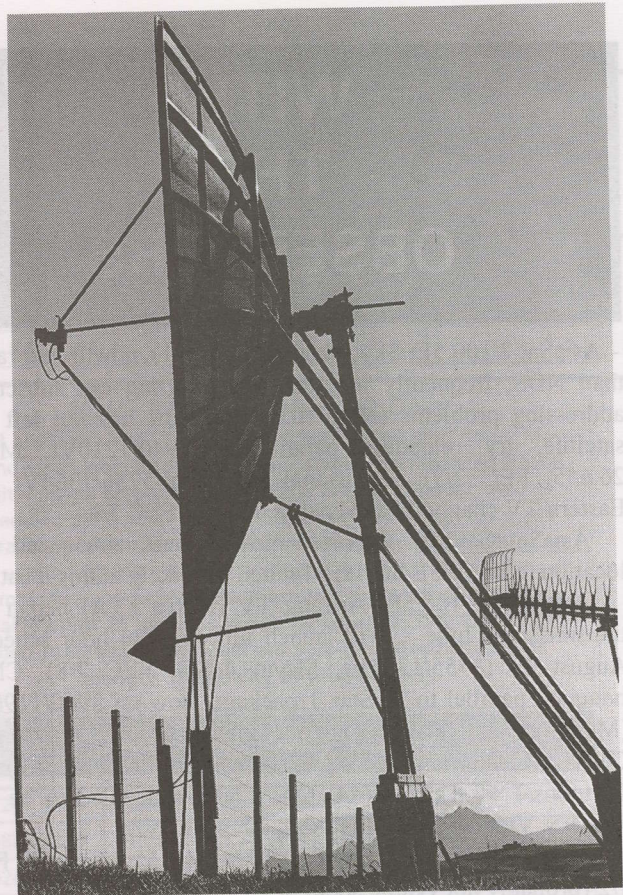

(3940/1210Vt) caused by defective waveguide to PAS-8 dish at Globecast uplink in Los Angeles; now scheduled June 15. NBC HK feed of National Geographic announced to close down June 15th, switching exclusively to As3S inside of Star

# JACOBSON'S

THE NEW GENERATION OF DIGITAL  
SAT. RECEIVER IS HERE!  
НОВОЕ ПОКОЛЕНИЕ ЦИФРОВЫХ СПУТНИКОВЫХ  
РЕСИВЕРОВ!  
9800S

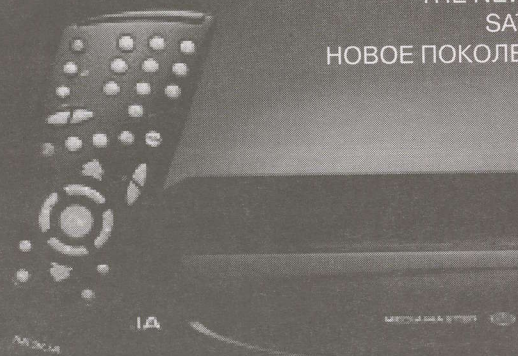

UNIQUE HIGHLY INTEGRATED ONE-CHIP SOLUTION WITH A TEN TIMES BETTER  
PROCESS CAPACITY....

MAKE SURE YOU BUY THE BEST! ASK US WHERE YOU CAN GET IT!

УНИКАЛЬНОЕ ВЫСОКОИНТЕГРИРОВАННОЕ РЕШЕНИЕ С ДЕСЯТИКРАТНЫМ  
УВЕЛИЧЕНИЕМ СКОРОСТИ ОБРАБОТКИ ИНФОРМАЦИИ....

БУДЬТЕ УВЕРЕНЫ - ВЫ ПОКУПАЕТЕ ЛУЧШЕЕ!

СПРОСИТЕ НАС, ГДЕ ВЫ МОЖЕТЕ ЭТО ПРИОБРЕСТИ!

JACOBSON'S, авторизованный дистрибьютор в следующих странах: Россия, Беларусь, Украина, Молдова, Грузия, Армения, Азербайджан, Казахстан, Туркмения, Киргизия, Таджикистан, Эстония, Латвия и Литва.

Nedralid S • 59197 Motala • SWEDEN • Phone: +46 141 220 331 • Fax: +46 141 220 111 • Website: www.jacobsons-t.s • E-mail: info@jacobsons-t.s  
Moldova • Tel: +46 141 220 060 • Mob: +46 706 80 06 24 • Ask us for catalogue!

**NOKIA**  
Receiving Equipment  
Direct to home

**EMITOR AB**  
Test equipment  
and accessories

**020**  
Digital cable-TV head  
equipment  
and Microwave link

**ELCON**  
Multi switches

**SMW**  
SWEDISH MICROWAVE  
Digital professional

**Channel Master**  
Satellite Antenna

TV Asia bouquet. NHK close down here continues day by day to be put off. SPN Guam Games coverage marred by problems with uplink- it was not your system.

**PAS8/166E:** TARBS service registers 85% on Phoenix 333, 12.524Hz (Msym 28.062, FEC 3/4) - much stronger than 20% from PAS-2 Ku feeds (P Cook, Qld). TARBS package C/N maximum 7 dB on 3m with 0.6 dB Gardiner - not usable here (**Holz**t, New Caledonia). Asian beam start-ups - FTA initially

(but not for long!): 12.366Vt (Msym 26.888, FEC 3/4 ) and 12.286Vt (Msym 26.888, FEC 3/4)

**Optus/Austar/Foxtel transponder loading**

<b>12(.438)</b>	<b>29(.473)</b>	<b>3/4</b>
SID 1101	BBC	
SID 1102		W21/fta
SID 1103	FOX	
SID 1104	UKTV	
SID 1105	HALL	Hallmark
SID 1106	FX	
SID 1107	KIDS	Fox Kids
<b>12(.564)</b>	<b>29(.473)</b>	<b>3/4</b>
SID 1301	MAIN	Main Evt
SID 1302	CMT	
SID 1303	SKYR	Sky Rac
SID 1304		open
SID 1305	MOV1	Movies 1
SID1306	MOVX	Movie Ex
SID1307	MOVG	Movie Gr
SID 1308	C7S	Sport 1

SID 1309	C7S2	Sport 2
SID 1310	ODYS	Odyssey
SID 1311	MTV	
SID 1312	SKYN	SkyNews
SID 4301	Ra 1	
SID 4302	Ra 2	
SID 4303	Ra 3	
SID 4304	Ra 4	
<b>12(.626)</b>	<b>29(.473)</b>	<b>3/4</b>
SID 1401	TNT	
SID 1402	W21	
SID 1403	CNBC	
SID 1404	WMOV	
SID 1405	TVSN	fta
SID 1406	CNNI	
SID 1407	ESPN	
SID 1408	OVAT	Ovation

SID 1409	A	
SID 1410	B	
SID 4401	Ra 5	
SID 4402	Ra 6	
SID 4403	Ra 7	
SID 4404	Ra 8	
SID 4405	Ra 9	
SID 4406	Ra 10	
SID 4407	Ra 11	
SID 4408	Ra 12	
SID 4409		
SID 9992	Pace	0x0202
SID 9998	SMS	0x0602
<b>12(.688)</b>	<b>29(.473)</b>	<b>3/4</b>
SID 0001	TV1	
SID 0002	SHOW	Showtime
SID 0003	ENCR	Encore

SID 0004	FS1	Fox Spt1
SID 0005	ARENA	
SID 0006	[V]	
SID 0007	NICK	
SID 0008	DISC	Disc Ch.
SID 0009	FS2	Fox Spt2
SID 0010	LIFE	Lifestyle
SID 0011	CMDY	Comedy
SID 0012	NGEO	Nat Geo.

By "interrogating" a Tandberg commercial MPEG-2 IRD, this table of Optus/Foxtel/Austar programme service channels was revealed (done in April, may be slightly changed). SID is service identification number, unique to each programme channel.



# MELBOURNE SATELLITES P/L

ACN 065 270 733  
Established 1992

Direct importers and suppliers of the following world renown products.

**KTI**  
**ORBITRON**  
**PATRIOT**  
**JONSA**  
**ANDREW**

**ECHOSTAR**  
**SCIENTIFIC ATLANTA**  
**NOKIA**  
**IKUSI**  
**DX**

**GARDINER**  
**CALIFORNIA AMPLIFIER**  
**MTI**  
**CHAPARRAL**  
**ADL**

Full range of cables, splitters and connectors.

Phone, fax or write for our 1998 Product SATalogue.

Sales/Warehouse - 84 Bayfield Road, Bayswater Victoria  
Construction Services - 13 Elsum Avenue, Bayswater Victoria  
Postal Address - PO Box 901, Bayswater 3153 Victoria Australia

Phone: (03) 9738 0888  
Fax: (03) 9729 8276

**User Friendly Site!**

[www.melbournesatellites.com.au](http://www.melbournesatellites.com.au)

e-mail: [sales@melbournesatellites.com.au](mailto:sales@melbournesatellites.com.au)

### Irdeto piracy takes an ugly turn

This is not a topic we enjoy reporting because it ultimately chops at the roots of a promising DTH business world. We last mentioned Irdeto piracy cards in some detail in our January issue, reporting the "Christmas Card" received in the mail from an anonymous source in Australia.

During the past five months, Internet postings and Web site sources for Irdeto busting information have exploded. I would say they are out of control, beyond any reasonable level we would expect if the piracy card game was limited to a mere handful of hackers. The sheer volume of postings and information can only bring us to one conclusion - thousands of people must now be hacking the cards.

While most Web sites are clearly commercial, designed to sell you something you don't already have (whether that be an Irdeto card ready to plug in and use, blank cards, second hand expired cards, or software to load your own card blanks) - the proliferation in new postings is predominantly from people who seem to hack for the sheer joy of hacking. A quote.

"I am not an expert in these matters, just a hobbyist who likes to learn. I have read the FAQs, the read-me files and postings in the various forums and then applied the knowledge gained to activate my own card." There follows 20 pages of instruction written in plain English. And there are warnings - plenty of warnings. Such as -

"If you can purchase a subscription for these TV services in your country then the procedures described here may well be illegal. This information is provided for educational purposes only and must not be used to get free TV."

And - "I will not supply any software that could be used for illegal purposes. Do not ask."

Some postings are very short. "Switch On all Australian Irdeto Bouquet" has four lines of numbers and letters apparently to aid users in modifying the code sequence found in a stock Austar or Foxtel card. The signature on this posting reads, "Made by Antonio have fun!!".

Having *fun* may be what this is all about. Chat groups dedicated to hacking pay-TV cards provide limited explanation for the level of hacking now underway. One year ago, much smaller postings and fewer participants often cited "the high cost of pay-TV" or "it is only for another country, not available in ours" as justification. Most of that is now gone.

The sale of Mark 12 card reader/writer devices, now Mark 13 and Mark 14, appears to make hacking almost pleasurable. The hundreds (or thousands) of web postings tell you what to do, what not to do, and encourage you to try new "tricks" and "share your results."

It remains illegal in most countries to sell hacked cards, but not to create piracy cards for your own use in your own home. Reader/writer hardware costs under US\$200 from

most sources (largely in Europe, frequently the UK). There are several levels of hacking common - taking an Austar or Foxtel card that functions for the least expensive service package and "opening them up" to receive the full package seems at the moment to be the most popular hack. It is much less common to take a brand new, never used Irdeto card blank (available in a slightly different form for under US\$5 from Hong Kong sources) and turn on a service for which they pay nothing at all. In effect, starting with an "authorised card" and then upgrading the services seems to be the limit of many hackers. But with plenty of time on their hands and several hundred dollars invested in a reader/writer, they persist to cruise the net searching for that elusive bit of "special" information that will allow a totally subscription free hack.

ECM (counter measure) card hits are apparently now a routine function for Austar and Foxtel; typically, I am told, around the last few days or start of a new month. After an ECM attack, an authorised card that has been "upgraded" to access additional unpaid services typically loses the hacked channels and that means the hacker has to re-enter the new numbers for a new month. There are advanced skills involved in getting around this ECM attack on pirate cards and finding these skills is another reason why enthusiasts stay with the game. Perhaps if they stopped the ECM measures, the enthusiasts would quickly lose interest in hacking.

It appears the latest level of hacking in Australia involves creating a "super card", one that unlocks some or all of the pay-TV services on B3 horizontal and on the flip side, some or all of the Aurora services on B3 vertical. The market for this knowledge could be considerable - people who have purchased UEC 642 or 660 IRDs for Aurora could avail themselves of the pay-TV packages as well. Aurora cards on their own have to date attracted only small interest - who wants to spend time hacking SBS, ABC, and those commercial broadcasters when for the same amount of effort and time you might access World Movies and ESPN? If, as we expect, Irdeto capable IRDs not from UEC or Panasonic begin to arrive in Australia, people will begin "shopping" for cards that possibly do as little as Aurora alone. And if the hacked Aurora cards happen to also open up all of the broadcast services (including GWN, WIN, Central 7, Imparja) - well, that is something the Optus issued cards cannot do in a single card.

How can the broadcasters put a lid on hacking? Trying to control the inflow of reader/writer devices would be a start but there is no legislation in place in Australia to implement such activity by government - and it would fail if attempted (firms shipping in reader/writers certainly don't identify them accurately on shipping papers!). Making Web sites that carry hacking instruction unavailable would be even less fruitful. Perhaps the answer - and there has to be one someplace - is to eliminate the incentive to hack. As long as the code streams are proprietary, the challenge to "break" the stream will be there.

What I fear most is that firms selling hardware, whether at the distributor or dealer level, will begin to consider "trick cards" as a "soft grey line crime" and rationalise that if they don't get involved, their hardware sales will suffer. Moreover, there may be serious legal questions concerning trick-Aurora cards. As a non-pay-TV service, perhaps the cards are not "protected" in the first place. We continue to live in "interesting times."

# THE 1999 SATELLITE EXPLOSION IN THE PACIFIC/ASIA!

**High Power NSS-K at 95E? Telekom 1 to 108E? The explosion continues!  
Stay tuned with SatFACTS!**

- ENTER my 12 MONTH subscription to SatFACTS starting with July 15th issue (rates below)  
 ENTER my 36 MONTH subscription to SatFACTS starting with July 15th issue (rates below)

NAME \_\_\_\_\_  
Company (if applicable) \_\_\_\_\_  
Mailing address \_\_\_\_\_  
Town/city \_\_\_\_\_ Country \_\_\_\_\_

**Amount to send:** 1 year - NZ\$60 (inside New Zealand) / A\$90 (inside Australia) / US\$60 (outside of NZ and Australia) or 3 years - NZ\$140 / A\$210 / US\$150 if by cheque. **VISA** or **Mastercard**? See form below and return with order. Return to: **SatFACTS, PO Box 330, Mangonui, Far North, New Zealand** or if by VISA or Mastercard fax to 64-9-406-1083

**IF YOU ARE IN AUSTRALIA - See AV-COMM Pty Ltd Advert p. 31!**

## USE THIS FORM ONLY WHEN CHARGING ON VISA/MASTERCARD

Please charge my **VISA/Mastercard** as follows:

- ONE Year of SatFACTS MONTHLY (NZ\$60, A\$90, US\$60)  
 THREE Years of SatFACTS MONTHLY (NZ\$140, A\$210, US\$150)  
 SATELLITE TELEVISION: The Booklet (NZ\$10, A\$12, US\$10)  
 One Year of COOP'S TECHNOLOGY DIGEST (NZ\$125, A\$125, US\$125)

Indicate charge card type:  VISA  Mastercard

Name (as it appears on **VISA / Mastercard**) \_\_\_\_\_  
**VISA/Mastercard** Number \_\_\_\_\_ - \_\_\_\_\_ - \_\_\_\_\_ - \_\_\_\_\_  
**VISA/Mastercard** expiration date \_\_\_\_\_

**Instructions:** If ordering by mail, return this complete (3-part) card or a copy of same (to **SatFACTS, PO Box 330, Mangonui, Far North, New Zealand**); if order by FAX, send full card as a single sheet to **64-9-406-1083**

**ALL COPIES OF SatFACTS Monthly are sent via Air Parcel Post world-wide!**

## SUPPLEMENTAL MATERIALS from SatFACTS MONTHLY: Order Form

- SATELLITE TELEVISION:** The Booklet. Excellent introduction to home dish ownership for the layman, including major contributions from the father of geostationary satellites - famed science fiction writer *Arthur C. Clarke*. The perfect tool to help the satellite system seller explain home satellite TV to the layman consumer. From SPACE Pacific. NZ\$10/ A\$12 / US\$10, airmail.
- COOP'S TECHNOLOGY DIGEST.** For the really serious enthusiast, investor, business person in satellite television and allied leading edge technologies. Ten issues each year, jam-packed with information you will not find anyplace else. "Coop" routinely culls more than 60 publications world-wide, terribly expensive newsletters, Internet and his hundreds of private contacts to keep you right at the leading edge of technology on the **REAL** changes underway in telecommunications. Conveniently issued near the **first of the month**, creating an excellent time-line-filler between the mid-month issues of SatFACTS. Now in the **6th year**, airmail world-wide. Normally NZ/A/US\$250 per year - for SatFACTS subscribers special 50% discounted price of NZ/A/US\$125.

# OBSERVER REPORTING FORM - Due July 5, 1999

- NEW programming sources seen since June 1st: \_\_\_\_\_
- Changes (signal level, transponder, programming content) in pre-existing programming sources since June 1st: \_\_\_\_\_
- OTHER (including changes in your receiving system): \_\_\_\_\_

NOTE: Please use P1 - P5 code when describing signal levels and receiver IF/RF settings.

Your Name \_\_\_\_\_

Town/City \_\_\_\_\_

Make/size dish \_\_\_\_\_ LNB \_\_\_\_\_ Receiver \_\_\_\_\_

Your email address \_\_\_\_\_ if you have one!

RETURN: SatFACTS, PO Box 330, Mangonui, Far North, NZ, fax 64-9-406-1083, Email Skyking@clear.net.nz

## MORE - SPACE Pacific technology research specials for June 1999

**DEEP-DEEP FRINGE AERIALIST ENGINEERING DATA:** From Coop's archives - the most complete step by step instructions ever created for the following super-antenna projects:

- ✓ "**Lost Art of Rhombic Antennas - 27 dB gain VHF and UHF!**" (CATJ magazine October 1976). Everything you need to build the most sensitive VHF-UHF receiving (or transmitting - just don't stand in front of it!) antenna known to man. This is the BIG ONE the pros use on over the horizon scatter circuits world-wide. Includes stacking instructions, fine-tuning LaPorte super-version. For a few hundred dollars you can build an antenna system that outperforms a stacked yagi array of 32 - 8 element antennas!!! *See below.*
- ✓ "**20 to 40 Foot Chicken Wire Parabolics**" (CATJ magazine, July 1974). Complete instructions to build UHF-TV off-air reception antenna system using poultry mesh reflector surface and stressed redwood (or other) timber struts and frame. 20 - 25 dB gain with 300 km range! Do it yourself, inexpensively, works where everything but a super rhombic fails. *See below.*
- ✓ "**The (world famous) Frias Half-Bolic Reflector**" (CATJ magazine, February/March 1978). Amazing half-parabolic design works over wide range of frontal angles simultaneously allowing you to set-up separate feeds for different channels arriving from varying frontal directions. City-grade (80 dBuV) signal levels at distances of 280 km on VHF (45 MHz) through UHF (900 MHz). This is a BIG antenna, and although you can (and will) build it yourself using commonly available hardware parts, it is still pretty big bucks. Nothing not even the Rhombic - covers such a wide frequency range over such a broad frontal arc with so much gain. *See below.*

## HERE IS HOW TO ORDER DEEP-DEEP FRINGE AERIALIST ENGINEERING DATA

Please send the following:

- Lost Art of Rhombics/\$20;  20 to 40 foot Chicken Wire Parabolics/\$20;  Frias Half-Bolic/\$20.  
OR -  ALL THREE (Rhombic, Parabolics, Half-Bolic)/\$50 + as a bonus - Surface Wave Logi construction project instructions (maximum-gain possible single channel TV antenna).

I wish to pay this by  cheque (enclosed)  VISA card  Mastercard

Card number \_\_\_\_\_ - \_\_\_\_\_ - \_\_\_\_\_ - \_\_\_\_\_ expires \_\_\_\_/\_\_\_\_

Ship to (name as appears on credit card):

\_\_\_\_\_ Company \_\_\_\_\_

Mailing address \_\_\_\_\_

Town/city \_\_\_\_\_

# Sky Vision Australia

*A Proudly Australian owned and operated company*



## SAT CRUISER DSR-101 MPEG 2 DVB / POWER Vu RECEIVER

***Latest Model – New Features  
Best value receiver in Australia !***

**Trade Price \$440** Ex Tax

- √ The ideal consumer orientated receiver with features that will please the enthusiast !
- √ Pre-programmed with all active TP's from Asiasat 2, Palapa, PAS 2 ,PAS 8 and more
- √ 10 spare user defined satellite positions for future satellite launches
- √ Simplified manual TP entry – TP Frequency is the only required parameter !
- √ Auto Symbol rate – Auto FEC – Auto PID's – Auto Polarity (LNBF)
- √ Satellite naming/editing – Channel naming/editing
- √ Alternate audio channels accessible from remote control
- √ On-board NTSC – PAL 50 Hz convertor – compatible with any PAL TV
- √ On-board Digital TELETEXT decoder – no need for Text capable TV
- √ 5 language menu - English (default) Spanish / Italian / French / German
- √ Consumer friendly graphical interface – Easy to install !
- √ UHF Ch 21-69 Software controlled RF Modulator – Low spurious emissions
- √ Low threshold dual bandwidth tuner – Dual SAW filter IF stage
- √ C Tick certified to comply with Australian Communications Authority standards
- √ Ultra reliable SMPS module – not a single reported failure to date !
- √ Full colour photographs and screen shots available from our web site
- √ 12 month replacement warranty – With an optional extended warranty plan
- √ Feel free to call one of our friendly staff for more information !

DSR-201P Analog/Digital/Positioner receiver ... Trade Price **\$640** Ex Tax

Export – Wholesale – Trade sales

Web Site: <http://www.bigfoot.com/~skyvision>

E-mail: [skyvision@bigfoot.com](mailto:skyvision@bigfoot.com)

Tel: 02 62925850

Fax: 02 62925890

# ANTEL

## Precision Offset Dishes



### Antel 1.2m Offset Dish

Minor Diameter	(cm)	120
Major Diameter	(cm)	135
Reception Range	(GHz)	10.95-12.75
Gain at 12.5GHz	(dB)	42.5
FD Ratio		0.52
Pole Size	(mm)	63
Wind Loading	(km/h)	160

Finish:

Dish

Epoxy-polyester powder  
coated galvanised steel

Mount

Zinc Plated

Weight

(kg) 16

### Antel 90cm Offset Dish

Minor Diameter	(cm)	90
Major Diameter	(cm)	100
Reception range:	(GHz)	10.95-12.75
Gain at 12.5-12.75GHz	(dB)	39.6
FD Ratio		0.50
Mast Clamp Range	(mm)	25-60
Wind Load	(N)	730

Finish:

Dish

Epoxy-polyester powder  
coated galvanised steel

Weight

(kg) 10



These quality products distributed by:



Phone: +61 8 9306 3738 Fax: +61 8 9306 3737  
sales@sciteq.com.au <http://www.sciteq.com.au>