

Bob Cooper's

APRIL 15 1999

# SatFACTS

MONTHLY

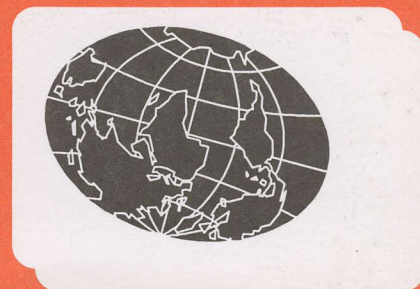

Reporting on "The World" of satellite television in the Pacific and Asia

## IN THIS ISSUE

**BER?**  
**Understanding**  
**the dBs**

**PanAmSat's**  
**PAS2-8 Free**  
**Antenna Project**

**RTIF Part 3 +**  
**As3 Status +**  
**The TV "Shoot"**

- ✓ Latest Programmer News
- ✓ Latest Hardware News
- ✓ Latest SPACE Pacific Reports
- ✓ Cable TV Connection

Vol. 5 ♦ No. 56  
Price Per Copy:  
NZ\$9/A\$10/US\$7





# Paraclipse<sup>®</sup>



CLASSIC  
SERIES

ECLIPSE  
SERIES

HYDRO  
SERIES

When quality, strength, and accuracy are your main requirements, **Paraclipse** antennas are your first choice.

Only **Paraclipse** offers such variety; four distinctly different series: the Truss-Ribbed Classic, the Courier Deliverable Eclipse, the Stretch Formed Hydro, the Commercial Patriot.

Every **Paraclipse** model sets the industry standard in its class, worldwide.

Distributed in Australia & the Pacific by

**SATECH Satellite  
Communication  
Technology Pty. Ltd.**

18/477 Warrigal Rd, Moorabbin  
East, Victoria, Australia 3189  
tel 61-3-9553-3399  
fax 61-3-9553-3393

**Paraclipse<sup>®</sup>**  
HIGH PERFORMANCE ANTENNAS

★ **MADE IN  
AMERICA**

Paraclipse Inc.  
2271 29th Avenue East, Columbus, Nebraska USA 68601  
Telephone: (402) 563-3625 Fax: (402) 564-2109



# SatFACTS MONTHLY

ISSN 1174-0779

is published 12 times each year (on or about the 15th of each month) by Far North Cablevision, Ltd.

This publication is dedicated to the premise that as we enter the 21st century, ancient 20th century notions concerning borders and boundaries no longer define a person's horizon. In the air, all around you, are microwave signals carrying messages of entertainment, information and education.

These messages are available to anyone willing to install the appropriate receiving equipment and, where applicable, pay a monthly or annual fee to receive the content of these messages in the privacy of their own home. Welcome to the 21st century - a world without borders, a world without boundaries.

**Editor/Publisher**  
Robert B. Cooper (ZL4AAA)  
**Office Manager**  
Gay V. Cooper (ZL1GG)

#### Reaching SatFACTS

Tel: 64-9-406-0651  
Fax: 64-9-406-1083  
Mail: PO Box 330  
Mangonui, Far North  
New Zealand

#### Subscription Rates

Within NZ: \$60 p/y  
Australia: AV-COMM Pty Ltd, PO Box  
225, Balgowlah, NSW 2093  
61-2-9949-7417  
Elsewhere: US\$60 p/y  
All copies sent via airmail fast post  
world-wide

#### ERRATA

SatFACTS Copyright 1999 by Robert B. Cooper; any form of copying is a violation of our international copyrights. Advertising rate sheet available upon request.

## COOP'S COMMENT

Some very good things are finally happening which will directly benefit Australian ethnic viewers as well as anyone who lives behind a hill where terrestrial reception is impaired. After nearly a year of negative news, the business world for privately owned DTH systems is starting to look productive again.

Last month on this page I took to task the A.B.A. for meddling in what should be a private decision by any Australian family who cannot receive viewable quality terrestrial TV reception from the 7, 9 and 10

national networks. The A.B.A. was trying to figure out how they could licence individual homes for satellite reception when the homes can not install a terrestrial TV antenna and create watchable pictures. We also reported how a NSW businessman was attempting to get the A.B.A. to accept home by home reception measurements as a criteria for authorising one-off satellite systems to provide reception which terrestrial TV cannot do.

An advisory prepared for SatFACTS by Chief Engineer Tim Mason of Imparja TV appears on page 14 in this issue. Mason's statement is simply this. If you are a dealer (or home viewer) who cannot install a terrestrial TV antenna at a specific location and receive "adequate service" from the national networks, Imparja can turn you on for their 9 + 10 service and TAL's Central 7 service. No matter where you live in Australia (with the exception of Western Australia which has similar twin services separately available). Subject to a testing procedure qualification process, that is an unqualified statement. Even for locations in downtown Sydney.

I consider this a major breakthrough for home dish system sellers and the viewing public so long deprived of "adequate service" levels from "local" terrestrial broadcasters. Mason and Imparja deserve credit for working out the "how to do it" details with the A.B.A. and I am equally certain our SatFACTS illumination of this issue also played a part in the final outcome. Final? Well, perhaps not final for this situation will not be totally equitable until each and every Australian home has full-time service from 7, 9 and 10 as three separate satellite delivered services nation-wide. But as an important first step, Imparja has crossed some very significant thresholds here.

Also this month comes news of the first legal Indian and Filipino service channels for Australia. Effective immediately (well, by the end of this month) Australian company Solution 42 (Pty Ltd) is offering, through AsiaSat 2/3S, subscriptions to the Star News India channel and the Filipino Viva! channel. Solution 42 has worked on this project through Star TV Asia for more than a year and it means that home dish systems sold by dealers (like you) can legally subscribe to either (or both) of these services with the blessing of Star TV Asia. For most homes, a 2.3m dish feeding a Pace DVS200-series IRD (also supplied by Solution 42 from Star TV Asia) and the all important smart card will be a relatively cost effective package. Solution 42 has structured this package so that DTH dealers can make money - by selling equipment and acting as agents for the programming software. The folks at 42 will be marketing the packages through ethnic newspapers and community groups, creating sales leads which will then go from 42 to their authorised dealers throughout Australia.

I find this concept to be sound, and am encouraged that for the first time this ethnic programming resale in Australia has the "blessing" of Star TV Asia. This is in its own way a major breakthrough for DTH dealers and we expect more packages to follow.



April 15, 1999

#### In Volume 5 ♦ Number 56

BER, S/N and C/N - The Relationship -p. 6  
PanAmSat's Antenna Replacement Programme -p. 10  
RTIF - Where It Went Wrong (part 3) -p. 14

#### Departments

Programmer/Programming Update -p.2; Hardware/Equipment Update -p. 4;  
SPACE Notes (Report on SPRSCS '99) -p. 20; Cable Connection  
(Cooling LNBs) - p. 22; SatFACTS Digital Watch -p. 24;  
Supplemental Digital Data -p. 26; SatFACTS Analogue Watch -p. 27; With The Observers -p. 29;  
At Sign-Off (Optus: Good and Bad Numbers) -p. 32

#### -ON THE COVER-

Retrofitting for PAS-8 + 2. New Zealand's Pacific Antennas Limited installs an RSI Hi-Net 5m for simultaneous PAS-2 and PAS-8 reception (p. 10)



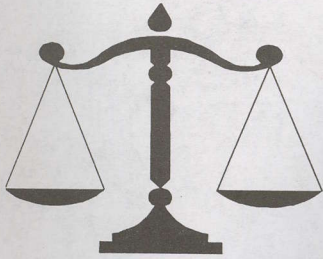

LETTERS

No Evidence

"I was surprised to read in the March 15 edition of SatFACTS (P15, RTIF - Where it went wrong) that "...some firms were able to obtain from a regional broadcaster (such as Imparja although there is limited evidence Imparja specifically allowed their viewer list to be used for marketing purposes)" (my italics). I am concerned that this wording might be taken as meaning that you have evidence that Imparja's database was made available for these purposes. I would like to make it clear to all SatFACTS readers that during this whole process Imparja has taken great care to ensure that its viewer database would not be available to anyone or any marketing purpose. We insisted that the RTIF (and their forerunner, the half transponder (analogue)) procedures be designed such that we retained sole access to the actual names and addresses of our viewers. As a result, Imparja made all mailouts, received all responses, and managed all of the interface between our viewers, the federal government, suppliers and dealers. The suggestion that we might in any way have provided commercial advantages to any organisation by providing them with access to our database is completely false. On the contrary, we have at all times gone out of our way to ensure that we provided no commercial advantage in any way to any organisation involved in this process. I am concerned that as a result of your statement, there may be questions raised about Imparja's proprietary in these matters and I would be grateful if you could publish a correction of this implication."

Tim Mason, Chief Engineer, Imparja Television

To set the record straight - SatFACTS has NO written evidence from any individual or firm in this industry that Imparja has in any way shared its private database with any firm. We have been told by people whom we suspected (at the time and now) had a commercial axe to grind that at least one supplier of IRDs had received access to the Imparja list. If Tim Mason says it never happened, that's good enough for us. This does not let Optus nor ABC off the hook, however.

SPACE Member Ingenuity

"Reference front cover photo SF for March 15. It was I - back on March 8, 1998 - who installed this system at the Whangamata Motor Camp. The local Sky Tech said he could not locate any Sky signal here and I was handed the assignment. Indeed, there was no signal at the home proper but probing around I found signal part way up the tree where by good fortunate somebody had lopped a branch years before. Some 100mm Tek screws and we were in business. No problems so far!"

Rolly Whitehead, Space Member

OK - so does Sky have a "side of tree" payment schedule category?

PROGRAMMER PROGRAMMING PROMOTION

UPDATE

APRIL 15, 1999

AsiaSat 3S testing at 98.2E as you read this (as we advised by Email April 2).

CNN will commence tests of PowerVu MPEG April 22 on PAS-8 (3780/1370Hz, Msym 25.000, FEC 3/4) - same transponder where CNN analogue appeared parallel to CNN on PAS-2 late in March - early April. CNN analogue on PAS-2 is scheduled to shut down May 31 and will be badly missed. TNT/Cartoon is also scheduled to start PAS-8 service (3940/1210Hz, Msym 27.690, FEC a dastardly 7/8) April 22, and shut down existing PAS-2 PowerVu link May 31.

Australian A.B.A. in response to terrestrial viewers who have degraded terrestrial reception seems to have reached an agreement with Imparja + TAL/QQQ (Central 7). Net result - if you have a customer who needs satellite to view 7, 9 and 10 networks - regardless of where they are located - satellite is now the answer. Imparja TV Chief Engineer Tim Mason explains how it works on p. 14, here.

Filipino and Indian origin residents of Australia may now subscribe to As2/3 Star TV services legally (no more pretending you are someplace else!). VIVA! for the Filipinos (or anyone who likes action filled movies) and Star News India are available nation-wide through Solution 42 Pty Ltd. DTH dealers who become affiliated with '42' will sell Pace DVS-200 series IRDs (equipped with the Star TV Asia provided smart card) along with typically 2.3m range dish, LNBF and parts which the dealer will supply. The dealers are in charge on this one, Solution 42 is the conduit for the otherwise impossible to obtain IRDs, cards and authorisations. The dealer sets the package price, collects commissions/fees and makes a profit on the install and hardware he provides. Solution 42 (Bill Kahn) at tel 02-9820-5962, fax 02-9820-1769, Email specsat@australia.net.au. Bad news? Only inside of Australia.

CMT will test their PowerVu encryption system May 12 between 3 and 6AM Sydney time, again June 9 from 3AM to 3PM. If you have not arranged to have your PowerVu 9223 or 9225 "addressed" as a CMT affiliate or you need to order an IRD, time is running out. Contact Tracy McKinley at tel 61-2-9460-8055, fax 61-2-9460-8066 or Email tracy@cmtv.com.au. If the 9223/9225 you are using or intend to use for CMT was originally sold for use with another service (any other service), you have a long road ahead of you - do not put it off until the last minute.

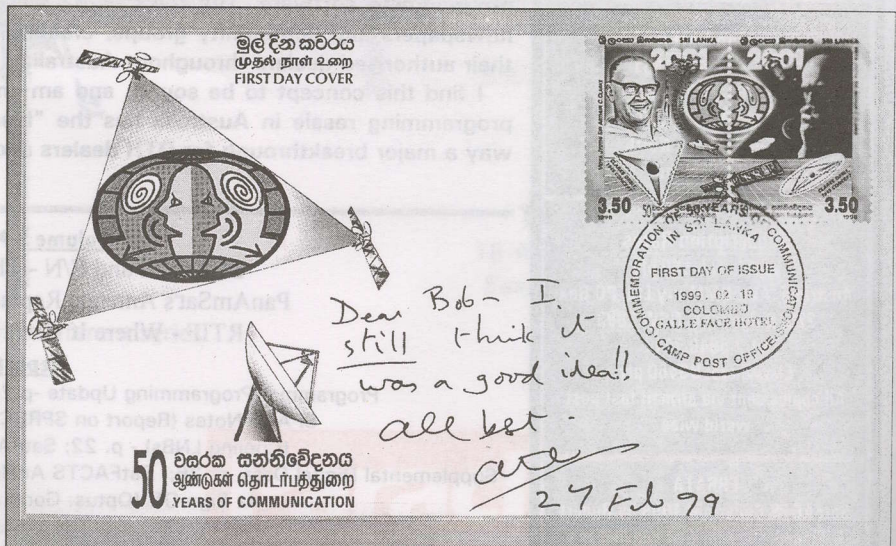

Sri Lanka has issued pair of stamps honouring the visionary Arthur C. Clarke and his postulation of the geostationary ("Clarke") orbit belt. Our official first day cover is especially unusual with note penned by Sir Arthur: "I still think it was a good idea!!" Indeed it was.



# Skandia

Free To Air

Skandia

## SATELLITE SPECIALISTS

***SKANDIA is the longest established satellite supplier still supporting the market with wholesale prices direct to the trade!!***

PART NO.	DESCRIPTION	A\$ EACH
SAT1013	Pace MSS138G receiver	160.00
SAT1014	DVS200 DVB compliant digital receiver	450.00
SAT1026	Strong SRT230 receiver	164.00
SAT1102	65cm dish offset pole mount	33.00
SAT1105	1.2M dish offset pole mount	126.00
SAT1116	1.8M dish 6 petal pole mount	179.00
SAT1120	90cm dish 6 petal pole mount	79.00
SAT1154	1.2M Paraclipse hydro AZ-EL mount	98.00
SAT1172	3.7M Patriot solid polar mount	5,800.00
SAT1173	3.7M Patriot dual axis mount kit	8,940.00
SAT1182	Quick set concrete 20 kgs.	6.00
SAT1403	LNB 20K C band digital extended	43.40
SAT1417	Combined LNBF/polarizer C band 20K	62.00
SAT1418	LNB Minimag C band 25K	49.00
SAT1419	LNB Minimag CalAmp C band digital 25K	82.50
SAT1427	Chaparral 20K vision C band LNBF	72.20
SAT1506	Chaparral polarotor C band	127.50
SAT1507	Jonsa dual polarity C band	35.90
SAT1510	Feed horn C band	19.90
SAT1518	Jonsa Ku band WR75 feed horn	10.00
SAT1602	12" actuator	66.00
SAT1603	18" actuator	96.00
SAT1604	24" actuator	145.00

- Prices exclude sales tax and freight.
- Above prices are valid until the end of April 1999 or while stocks last..
- Terms strictly cash or credit card only.
- Phone Mark or Fred on 6 13 9819-2466 or fax your order to 61 3 9819-4281.

### **ASK ABOUT OUR RANGE OF TEST EQUIPMENT**

**Skandia Electronics Pty Ltd**

**Victoria:** 183 Burwood Road Hawthorn 3122, Australia

Telephone: (03) 9819 2466 Fax: (03) 9819 4281

A.C.N. 005 560 903

Website: [www.skandia.com.au](http://www.skandia.com.au)

Email: [skandia@skandia.com.au](mailto:skandia@skandia.com.au)



### Starting Someplace

"Enclosed my subscription for SatFACTS. Please could you send me information about how satellites work, what one needs to know to install satellite receive systems? Is there a course I could take at home to learn more about this field?"

William Van Klaveren, Upper Hutt, NZ

One of the best \$10 educations you can get is our SPACE Pacific booklet prepared with material originally written by the "Father" of satellites, Arthur C. Clarke. See page 33 for ordering information. The Mark Long courses created for SPACE Pacific are for serious people who want to learn all they can about this rapidly-evolving field (see info card tick off on page 34).

### Austar Not Available

"I telephoned Austar, told them I was moving to Derby (and later Halls Creek) in WA and would like the service there. They said I would not be in their area, to ring Foxtel. And Foxtel admitted I was in their area but said, 'We have not started transmitting there yet.' This makes the story that Austar is responsible for regional areas a farce. What is this about 'not transmitting there - yet?'"

David Nolan, Katherine, NT

The Austar/Foxtel/nee Optus quartet of pay-TV transponders on B3 horizontal cover all of Australia. When Foxtel says, "We are not transmitting there" (Derby, Halls Creek), what they really mean is they are not prepared to make installations there - yet. The signal is on the ground, all you need is the appropriate size dish and the usual Austar/Foxtel/nee Optus attachments. So get some advice on what size dish you would require in WA, sign up for the service from your Katherine location and haul the gear out to Derby / Halls Creek and put it in yourself. Installing a home dish system may be satellite TV but it ain't rocket science!

### Searching for Iran

"I have followed your advice and left my analogue receiver parked on AsiaSat 2, 3680 Hz, from midnight local time until we get up each day, running our VHS recorder hoping to catch transmissions from Iran as listed in SatFACTS. We have had no success. Can anyone help?"

Ahmad Mobasher, Auckland, NZ

OK - if Iran is not transmitting on As 2 as was previously reported - can anyone tell us where they can now be found? Ahmad bought this dish after promising his family they could have Iranian TV from home and now it seems not to be there, we have a "domestic" problem that needs to be resolved.

### Aurora Trash

"After viewing a program from BTV1, Aurora (CITEC private use) the service provider switched on a test card prior to reactivating the encryption. The instant the test card came on, all of my other channels went crazy. Some froze up, others had sections of the BTV1 test card intermixed with regular channels. Only TVSN, BTV1 and Horizon stayed clean. Do you know if they are encountering this sort of problem with the Aurora service?"

Garry Luxton, Mt Hutton, NSW

Aurora problems have been considerable but appear to be less frequent each week. This is very new territory and Optus has their hands full learning the limits of the system.

## HARDWARE EQUIPMENT PARTS

## UPDATE

APRIL 15, 1999

**Squeaky wheel department.** Who says complaining does not work? Steffen Holz was contracted to install a new Patriot 4.5m dish for RFO New Caledonia and after installation measured 1.5 dB headroom on the Intelsat 180 feed (he computer readout said it should be closer to 4 dB). You may recall NSW and other reporters have been telling us this service had fallen off in recent months. Holz called Intelsat Operations Control (USA at ++1-202-364-4000) and they checked, sending him directly to Canadian uplink that provides the RFO feeds (++1-250-749-6646). There he found someone to check their transmitter power. "By golly" said the man, "we are down several dB. Here, let me fix that!" and instantly up came the level. We have found Intelsat exceptionally helpful with matters such as this in past; other satellite operators could take lessons from this.

**Technical help** with stubborn digital IRD faults? Try [satcure@netcentral.co.uk](mailto:satcure@netcentral.co.uk) and in initial Email explain your own servicing background and qualifications as "entry fee." Another source for technical help (analogue and digital) is well known UK technical trouble shooter Jack Armstrong at [jack@netcentral.co.uk](mailto:jack@netcentral.co.uk). Armstrong limits you to one receiver problem per query.

**NHK loading faults** on PAS-8? The data stream is frequently "corrupted" and may require multiple attempts for loading and FTA service.

**Solar eclipse degradation.** Something else we learned about FEC 7/8 during just-passed solar outages. It goes fast and stays gone long. Can PanAmSat really believe FEC 7/8 is suitable for their birds???

**Aurora loading** on B3 now essentially complete - "glitches" you see are usually not Optus created, rather part of learning curve for broadcasters using this service and their "pre-processing" of data streams before handing over to Optus for uplinking. Remaining problems characterised by "E16 - Service is currently encrypted" for 3 - 5 seconds at a time - audio and video is not affected, incorrect notice lays on top of video.

**PAS-8 dish changeouts** in Australia came to halt - perhaps temporary, perhaps not? - second week in April. Is there a message here?

**ABC PAS-2 Ku PowerVu services** on 12.638 and 12.629 are "off the air" until further notice; 12.646 continues running. Data feeds on the two now shut down are a possibility.

**National advertising** on Imparja et al noticeably increased - have the advertisers discovered the importance of the new "national" coverage system?



**Something for nothing** - almost. During SPRSCS '99 at Far North Cable TV, attendees Dave Horne (NZ, left) Pietro Casoar (Australia, centre) and Richard Brooks (Marshall Islands, right) went looking for Cakrawarta 1 signals with pole mounted S-band feed and LNB offset from prime focus feed of 3.7m. They found 12 dB C/NR service just above and slightly north of C2 focus point. Of course it is encrypted..



# ADL<sup>®</sup>

BECAUSE PERFORMANCE IS ALWAYS YOUR FIRST PRIORITY

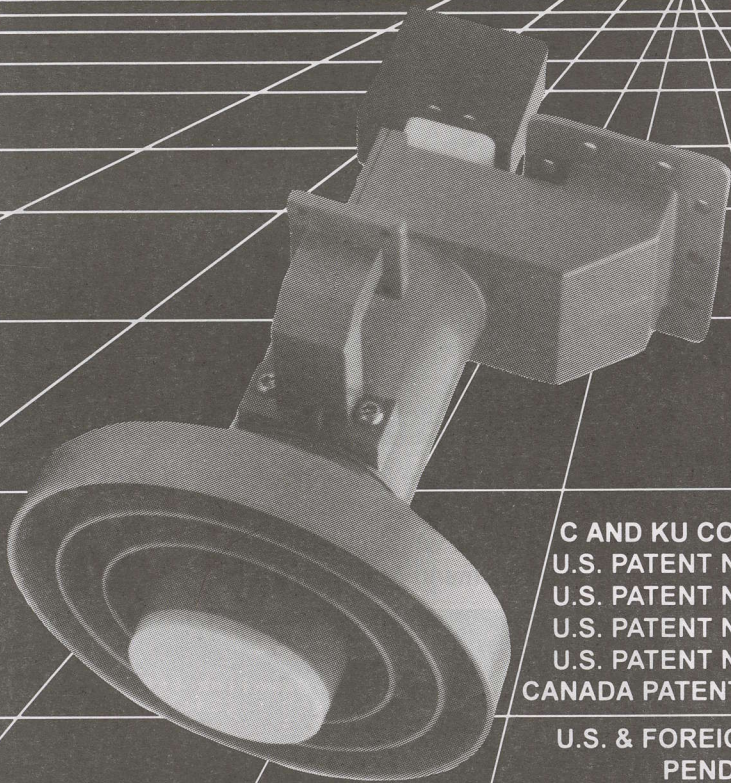

**RP3-CKU/ International  
Adjustable Scalar Ring Feed  
with Extended C Band**

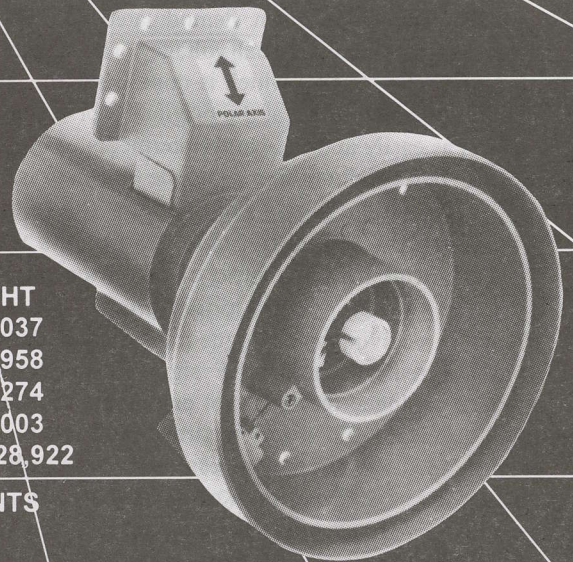

**RPI-CKU Feed**

**C AND KU CO-BORSIGHT  
U.S. PATENT NO. 4,903,037  
U.S. PATENT NO. 5,066,958  
U.S. PATENT NO. 5,107,274  
U.S. PATENT NO. 5,255,003  
CANADA PATENT NO. 1,328,922**

**U.S. & FOREIGN PATENTS  
PENDING**

## **ADL HYBRID MODING CIRCULAR POLARIZED INTELSAT FEEDS WITH EXCLUSIVE T.I. REJECTION**

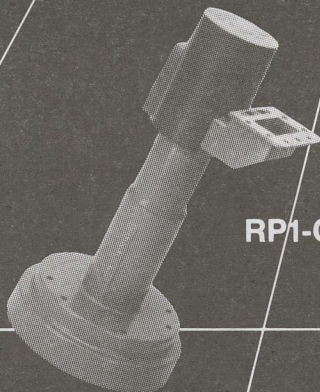

**RP1-CP400**

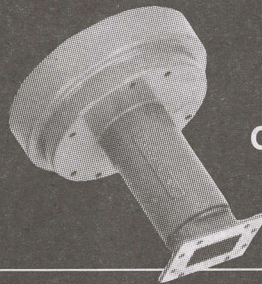

**CP-300**



**CPOR-100**

- C BAND LINEAR & CIRCULAR • C/KU LINEAR & CIRCULAR • KU 12 GHz FEEDS
- INTELSAT 4 GHz CIRCULAR • ARABSAT S BAND FEEDS
- OPTIONAL: CO-BORSIGHT S BAND

2216 AGATE COURT, UNIT B, SIMI VALLEY, CALIFORNIA 93065 • (805) 526-5249 • FAX (805) 584-0634

**NEW ADL Web site - [www.adlfeed.com](http://www.adlfeed.com)**



How do you *know* it is better?

## THE BER (Bit Error Rate) CONFUSION

Coming from an analogue transmission format world, the problem does not appear to be that complicated. If we know or can calculate the actual threshold point of reception, is it not possible to then calculate or measure how much "headroom" (excess signal above threshold) we have?

In the analogue world we have two separate measurements that are of interest. Both measurements are indirectly related to the bandwidth (B/W) of the transmitted signal. First there is the video signal to noise ratio (S/NR) which is done after the satellite signal has been demodulated (turned from an RF signal to a baseband signal voltage). The second is the carrier to noise ratio (C/NR) which is done while the signal is still in radio frequency form (at the original C or Ku band frequency, or just as easily at the L-band [intermediate] frequency).

The "pure" definition of analogue threshold is:

**"Threshold is the point where the relationship between the signal to noise ratio of the video and the carrier to noise ratio of the incoming signal is no longer linear."**

When receiving an analogue transmission, the video S/NR is always greater than the RF signal's C/NR. At threshold, a typical analogue receiver (not employing threshold extension) will produce a S/NR in the region of 45 to 48 dB. The threshold C/NR can be between 6 dB and 11 dB at this point - a function of the bandwidth of the transmission, and the signal processing circuits in the analogue receiver.

Digital transmission changes all of the rules. By some definitions digital threshold occurs when the picture "locks" and can be viewed. If this occurs at a C/NR or 6 dB, then we are likely to say "digital threshold for this receiver (IRD) is 6 dB." Furthermore, once the digital picture has locked, the video S/NR is instantly in the region of 52(+) dB. It is not likely you will ever view a digital signal with a video S/NR of 48 dB (one point of analogue threshold) because the digital processing circuits will simply refuse to lock on any video S/NR that falls below the equivalent of approximately 52 dB.

The definition of digital threshold is not as easy to determine because it is a "floating point" affected by transmission parameters such as the forward error correction (FEC) rate. In the analogue world, all noise interference in the picture will not necessarily be gone once we reach "threshold." In fact, the last "sparklies" (noise hits) in a saturated red or blue image typically are not totally gone until the receiver's C/NR is 3 to 4 dB greater than threshold. To put some numbers to the reception quality, a video S/NR of 52+ dB (the point where digital reception locks) may not be reached with an analogue image until the C/NR is in the region of 14 to 17 dB.

Moreover, digital "lock" may not represent a suitable definition of digital threshold. Lock means the processing circuits in the receiver are able to "correct" for any noise bits or missing signal data bits to the degree that a less than perfect image can be "corrected" by the receiver's circuits. Each image



PIXELATION. Image locks, goes into squares and tiles at threshold point (above). BER indicator indicates point at which threshold is reached (below - installer menu readout from SA D9223).

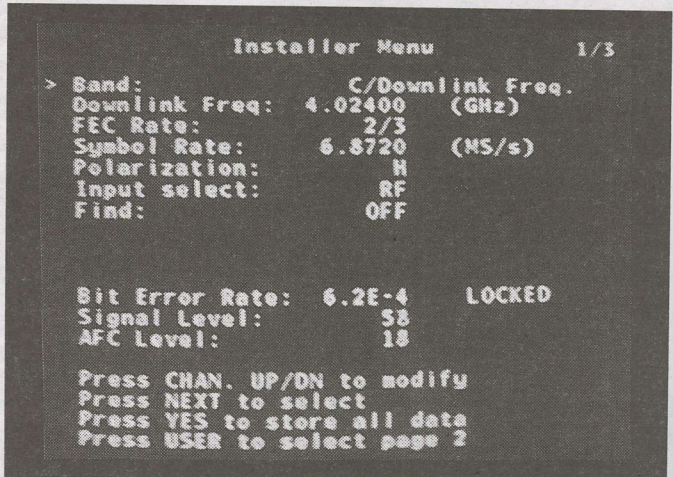

Spectrum analyser display (below) reveals apparent digital carrier to noise ratio (C/N) but does not consider FEC rate of service.

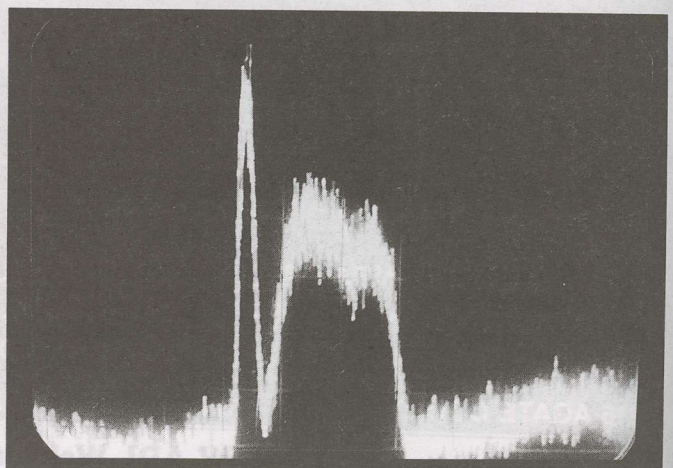



## HOW FEC AFFECTS THRESHOLD

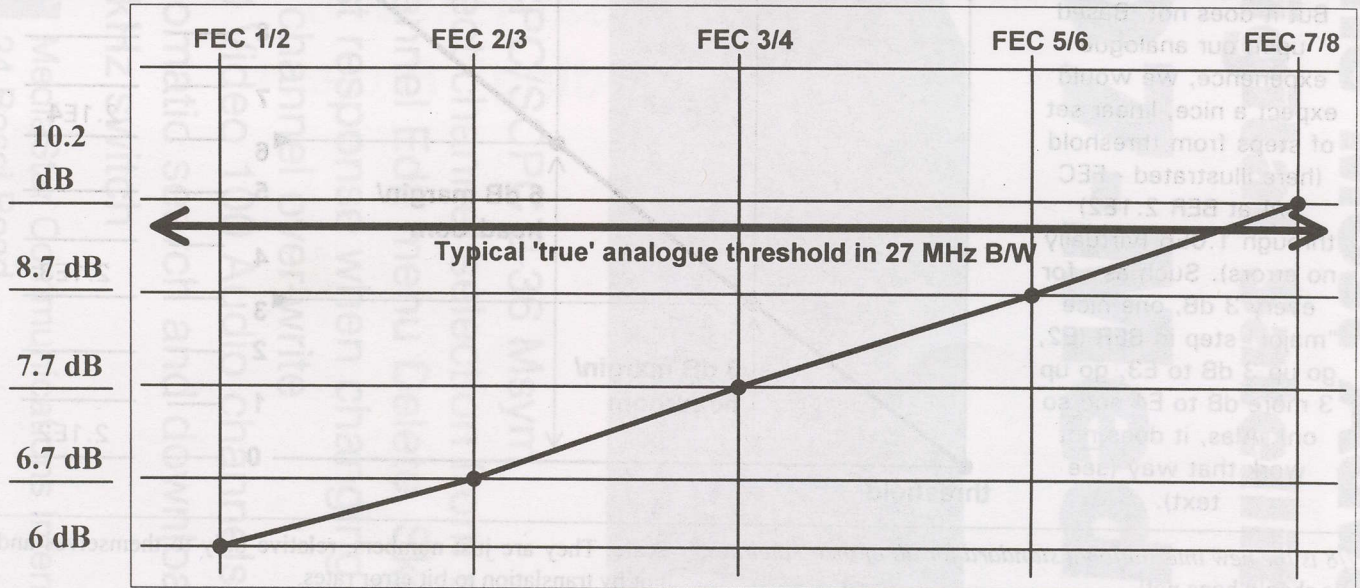

	FEC 1/2	FEC 2/3	FEC 3/4	FEC 5/6	FEC 7/8
↑ C/N	3.6m	4.3m	5.0m	5.6m	6.2m
	3m	3.3m	3.7m	4.4m	5.2m
→ dish size	2.4m	2.6m	2.9m	3.3m	3.8m
	1.8m	2.0m	2.3m	2.5m	2.9m

**Threshold approximation:** If you are receiving a C-band FEC 1/2 service and it is exactly at threshold (occasional pixelation), and your dish is 3m in size - change the FEC of the same service to 3/4, you will be 1.7 dB below threshold. At FEC 5/6, 2.7 dB below threshold. And at FEC 7/8, 4.2 dB below threshold. Or - a 3m dish would have to be upgraded to a 5.2m dish to achieve the same position relative to threshold at FEC 7/8 as you have at FEC 1/2.

is a "frame" and in theory the PAL frame rate is 25 per second (NTSC is 30 per second). Within each frame are millions of data "bits" which must be processed by the IRD. When some of these bits are "lost" or buried by "noise," the IRD attempts using the FEC circuit to hide or mask the missing or corrupted bits. When the number of bad bits passes a "threshold" point, the receiver unlocks and you have pixelation (frozen or partially frozen images) while the IRD struggles to correct the below threshold reception on the succeeding frames received. So threshold, the point where the IRD loses the ability to process an image, is not the same as no errors in the transmission received. And just as it takes several dB of signal

greater than threshold to remove the last noise hits (sparklies) from an analogue service, digital also requires more C/NR (signal) to reduce the errors which FEC attempts to correct.

In fact, the FEC variable plays a very important role in determining how much C/NR you require to produce digital threshold. We show that in table and graphic form here. Those who have compared the performance on the PAS-8 transmission of EWTN (FEC 7/8) with the PAS-2 performance of EWTN (FEC 3/4) have already discovered that as the FEC rate goes up, the threshold point for digital reception also increases. Of interest, those who have complained to EWTN about losing service have been told, "PanAmSat advises FEC

FEC rate	BER at threshold	Improvement in threshold	Analogue reference notes
1/2	7.0E2	0.7 dB better than 2/3	4.2 dB better than 7/8
2/3	3.6E2	1.0 dB better than 3/4	3.5 dB better than 7/8
3/4	2.1E2	1.0 dB better than 5/6	2.5 dB better than 7/8
5/6	1.2E2	1.5 dB better than 7/8	1.5 dB better than 7/8
7/8	7.7E3		equivalent analogue threshold



**What we think it should look like**

But it does not. Based upon our analogue experience, we would expect a nice, linear set of steps from threshold (here illustrated - FEC 3/4 at BER 2.1E2) through 1.0E6 (virtually no errors). Such as - for every 3 dB, one nice "major" step in BER (E2, go up 3 dB to E3, go up 3 more dB to E4 and so on). Alas, it does not work that way (see text).

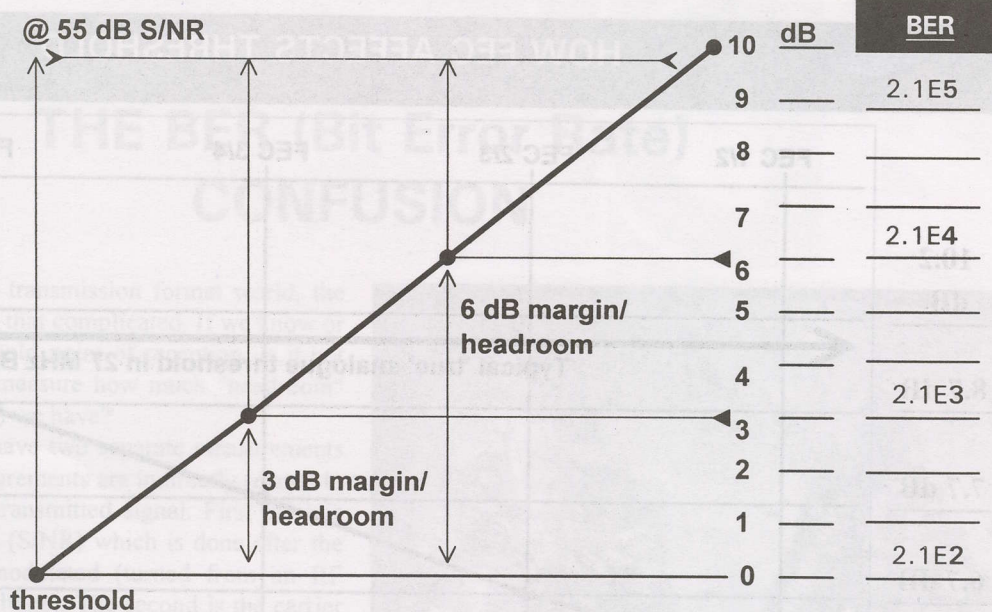

*7/8 is the new international standard for all of their satellites.* We should hope not!

Why would a service provider deliberately select an FEC rate that demands a significantly larger antenna for reception? It is the decades old game of transferring coverage responsibility from the satellite operator to the receive system designer. FEC 7/8 allows the satellite operator to cram more data into the stream. More data means more programmer customers which in turn means more revenue for PanAmSat. If they can force the viewers to install larger dishes so that PanAmSat can increase their revenue from users - why not?

**Not As You Think** (or hope)

One of the reasons why you have never seen a published chart like those appearing here (for the first time) is that - in complete honesty - these charts are only guides. They are not 100% accurate under all situations.

Engineer I. Kwan (Hong Kong) has spent several years evaluating digital IRDs under FEC rates from 1/2 to 7/8 hoping to find a way to quantify IRD performance.

"First of all, you cannot trust what the receiver is telling you. For most IRDs that bring up on screen some sort of 'quality' number, the numbers are not pegged to any known engineering

scale. They are just numbers, relative only to themselves and not by translation to bit error rates.

"SA, NDS and other professional receivers that claim to relate the BER are at best estimating. I have found with receivers in a complete bench test set-up that the bit error rate compresses - it is not linear. As the C/N increases, the rate of change of the bit error rate typically decreases. And no two receivers act or measure the same which tells me there is no real standard at work here.

"If, as an example, you can measure a 3 dB C/N change between 1.0E3 and 1.0E4 for a specific IRD, it is erroneous to assume (1) another 3 dB C/N will get you to 1.0E5, or, (2) another receiver (even of the same brand and model) will also change from 1.0E3 to 1.0E4 when subjected to a 3 dB C/N improvement.

"We can only be certain that an increase in C/N will result in an increase in BER (or indicated picture quality on a less sophisticated non-BER-reading IRD). And even that cannot be a blanket statement. Try inserting a 3 dB power passing pad in the line between the IRD and the LNB and watch what happens to the BER (signal quality) reading. If 3 dB less signal actually *improves* the BER/quality, as it will sometimes, you know you are in for a wild ride!"

THE REALITY - is that low and medium priced analogue intended spectrum analysers give only "relative" indications of digital SCPC/MCPC "power envelopes." YES - the right hand display is stronger than the left hand display. But not by 2 dB and in fact the indicated C/N for displays will read "high" by as much as 20%.

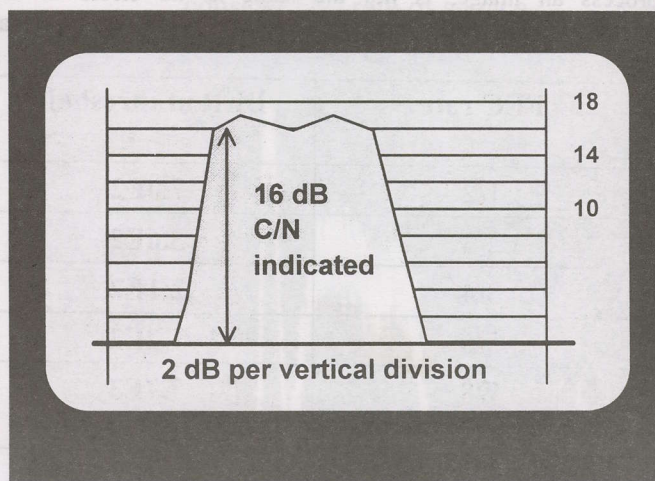
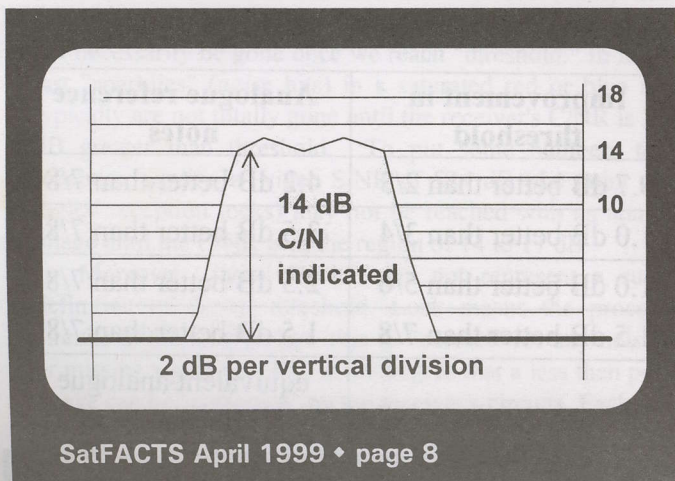



# The Most Advanced Free To Air Digital Satellite Receiver

## D7-MediaStar

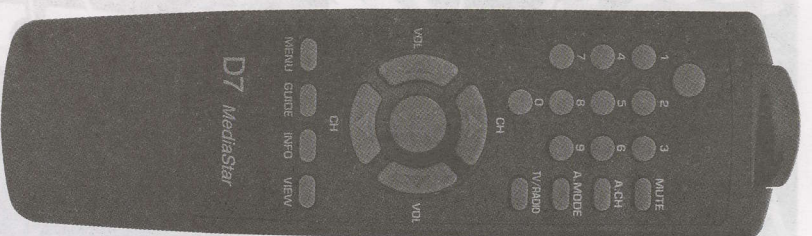
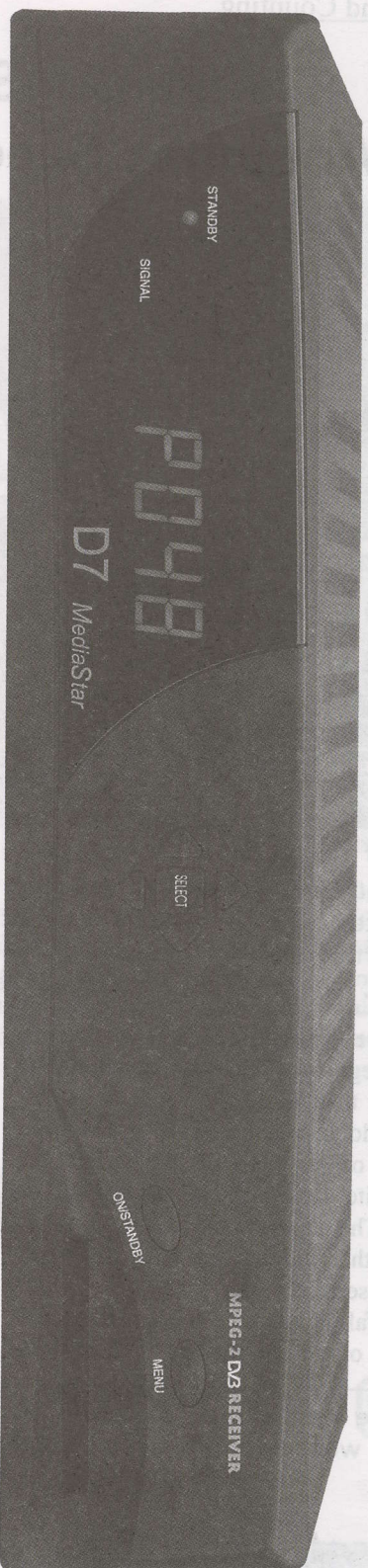

- MCPC/SCPC 2-36 Msym
- Direct channel selection from channel list
- Channel Edit menu Delete, Skip, ON.
- Fast response when changing channels
- No channel over-write
- 200 Video 100 Audio channels
- Automatic search and download
- 22 KHz switch
- PID Menu
- NTSC/PAL Auto switching NO NTSC Glitch
- NTSC converted to PAL-60Hz Free Option
- Audio L, R, Stereo selectable via remote control
- RF Modulator PAL-G, VCR/TV Scarts, RCA Audio/Video, SVHS outputs.
- 90-265VAC-50-60Hz power supply
- Low threshold performance



MediaStar Communications International  
24 Bosci Road  
Ingleburn NSW 2565 Australia

E-mail opac@bigpond.com  
Tel ++61 2 9618 5777  
Fax ++61 2 9618 5077



## The PanAmSat PAS2-8 Antenna "Seeding" Project

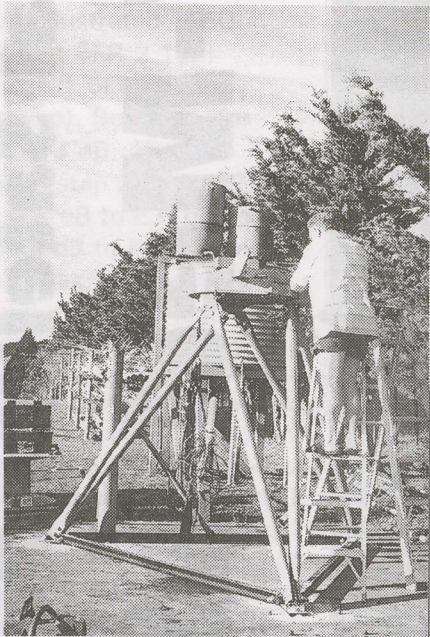

With plenty of cured concrete in the ground, you start with the galvanised steel mount (left photo). This is a tri-legged support system with a "turntable" style azimuth rotating ring. Next comes the centre plate to which all of the support struts will attach (centre) and the real "fun" begins - attacking the bags of more than 500 bolts, nuts and washers to build the parabolic reflector a piece at a time (right).

The concept is imaginative, bold, and perhaps borders on corporate foolishness. You begin with a C + Ku band satellite that is carrying more traffic than it should be (in a word - "overloaded"). Then you add a brand new C + Ku band satellite that sits 3 degrees off to one side. To lighten the traffic load on the first satellite, some services using it will be moved to the new satellite. The plan is to move enough traffic from the first to the second that both end up with overhead - room to add additional new users.

Users of the first satellite fall into two categories; those that are paying customers for one or more of the first-bird services,

and those that are free loading - FTA viewing. The first group counts, the second one is ignored. Within the first group are some who pay lots of money each month for services received, others who pay very little. The challenge is to select which of the programmers now using the first bird will be "talked into" moving to the second bird. There is a reluctance to move - programmers who serve lots of customers don't want to lose any of their customers by moving to a satellite that requires a new dish antenna on the ground.

The solution - PanAmSat believed - was to "salt the earth" with new terminals. Working with the programmers (CNN,

The 24 parabolic curve struts ("truss") support 24 parabolic shaped panel sections (left). The assembly remains very "fluid" (it wobbles a lot) until the between strut supports ( "intercostal") are installed (right).

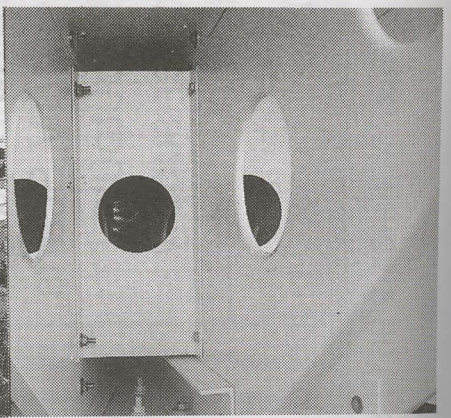
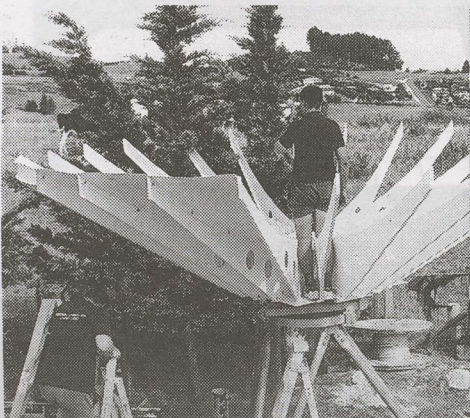



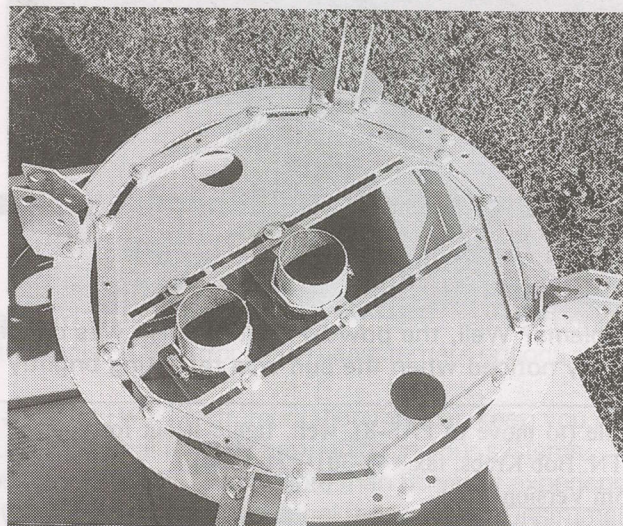
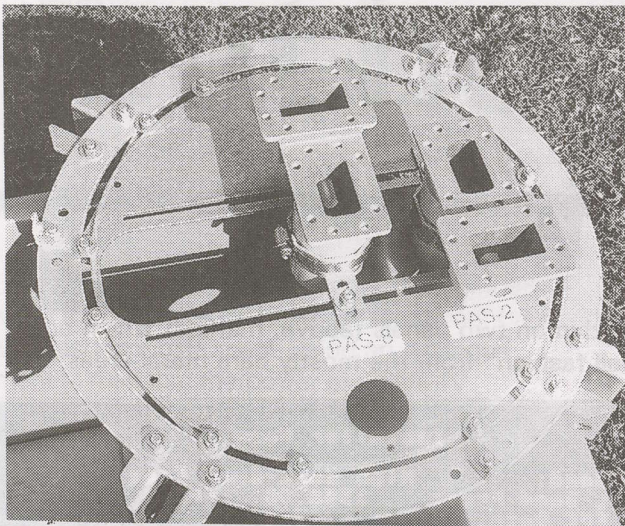

One very large feed support assembly. Custom designed for PAS-2 + PAS-8 service, this is the dual-bird mechanism equipped with pair of Chaparral dual-pole feeds and designed to be fed with California Amplifier LNBS. No, you wouldn't want this chunk of metal in front of a "small" dish!

EWTN, Discovery, TNT, NHK and others) PanAmSat developed a list of earth terminal users - customers - who would require a new antenna for PAS-8 if the programmers did move to the new satellite. There were more than 3,000 terminal locations identified - in theory each would be entitled to a new antenna from PanAmSat. In the majority of locations, (Patriot) 3.1m antennas could be used with progressively fewer

and fewer up to 5m. Some locations (Fiji, Marshall Islands are two) would require an even bigger dish - perhaps a 7m.

Hint number one: To qualify for a "free dish" from PanAmSat, first you must be "affiliated" with one of the programmers planning to move to PAS-8 and ideally also have an affiliation with one of the programmers staying on PAS-2. If you secure an affiliation agreement with EWTN, for

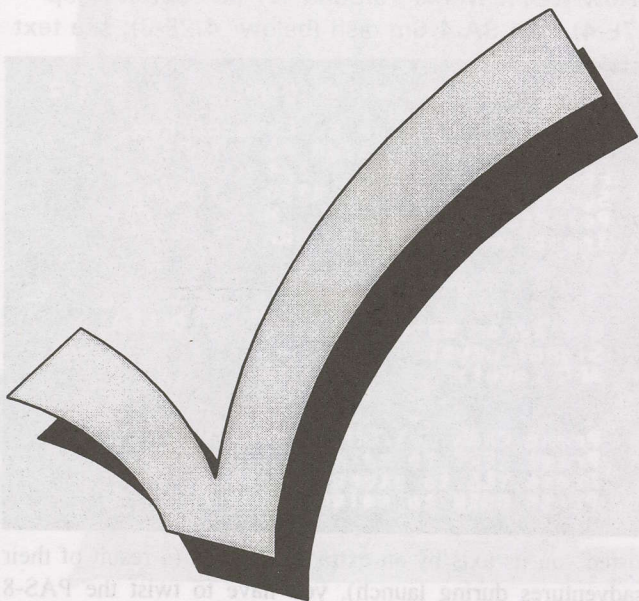

**IT OUT.**

**A SatFACTS advertisement this large (1/2 page) is as low as  
US\$118.58 per issue.**

Details? Email [Skyking@clear.net.nz](mailto:Skyking@clear.net.nz) or telephone 64-9-406-0651, fax 64-9-406-1083



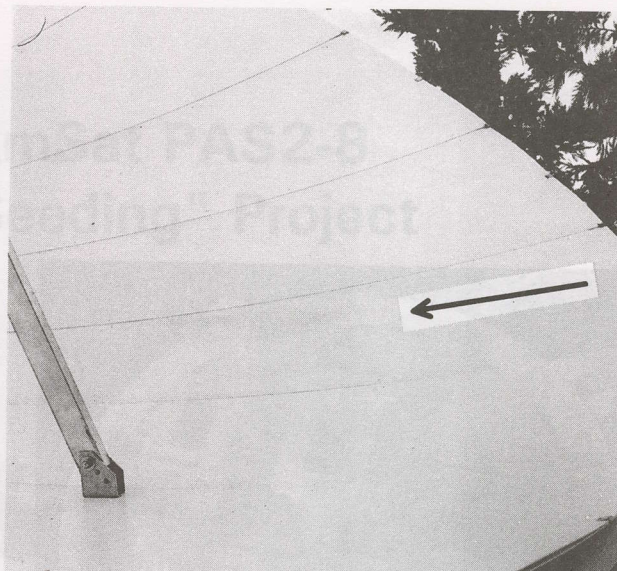
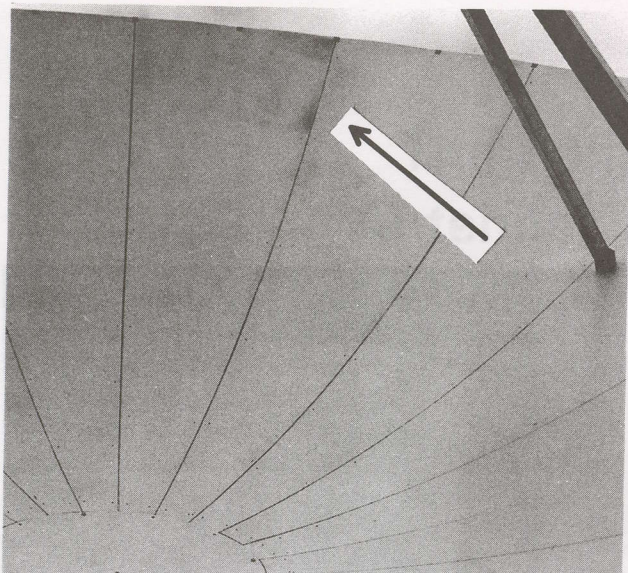

Problems? Well, the powder coated finish was dangerously thin on two panels (above, marked) which one only noticed when the sun was reflecting brightly "fireball fashion" from the mostly bare metal areas.

example (to move to PAS-8), well, figure it out for yourself (EWTN: Bob Krebs, fax ++1-301-271-5336).

#### The 5m Version

Because of weaker PAS-2 services already in use on a 4.5m dish, Far North Cable TV (NZ) required a 5m dish for dual illumination of PAS-2 + 8. The 2,000 pound (shipping weight), 300 cubic foot monster crate(s) were shipped by air freight (!). Installation was arranged through Pacific Antennas Limited (64-9-424-0841) where head honcho Bryon Evans admitted to being personally responsible for "approximately 50" installs of this RSI Hi-Net (ex Holiday Inns) system. Pacific arrived at 7AM, with a crew of four, and we had spectrum analyser displays by 3PM. The photos tell most of the story.

Some of the PanAmSat supplied antennas are remanufactured (including our 5m). That means they've been up, worked for some period of time, were taken down, "reconditioned" and repacked for shipment. The RSI literature (and PanAmSat) told us this was a Ku-rated antenna. What better way to prove this than by temporarily equipping it with a Ku band feed and making measurements? If it performed properly at the more critical Ku-band wavelengths, proper operation at C-band would be assured.

It happened our permanent Ku band dish, a Scientific Atlanta 4.6m, was handy for reference. Using identical LNBS and appropriate feeds on both antennas, we spent several hours wringing the last 0.1 dB of gain out of both antennas. You can see the results to the right - bit error rate comparison between both antennas simultaneously.

As for the model MBF multiple satellite feed system - well. The same model feed system (see photos on p. 11, bottom) is apparently used for the full range of antennas - 3.1m up to 5m. The large (.5 m diameter) plate is supported by custom designed quad (4) leg supports. The feed is supplied assuming you will put PAS-8 at the centre of the dish and offset the PAS-2 feed (by 13cm). In our case, PAS-2 service is more critical to us than PAS-8 so we reversed the feed locations (simply relabel them). The loss for the offset feed is at least 1.5dB and with the 0.5m steel plate blocking the centre of the dish, it would be closer to 3 dB for a smaller dish (such as the 3.1m Patriot, which is 16% [centre] blocked by the feed array).

PanAmSat supplies four C-band LNBS to mate to the non-scalar ring equipped Chaparral feeds. Because PAS-8 is

```

Installer Menu 1/2
> Band: High Ku/L-Band Freq.
L-Band Freq: 1388.00 (MHz)
FEC Rate: 3/4
Symbol Rate: 29.4730 (MS/s)
Polarization: H
Input select: RF

Bit Error Rate: 8.7E-4 LOCKED
Signal Level: 30
AFC Level: -3

Press CHAN. UP/DN to modify
Press NEXT to select
Press YES to store all data
Press USER to select page 2
  
```

How well it works - around 1.7 dB "better" (top- 8.7E-4) than SA 4.6m dish (below- 4.2E-3); see text

```

Installer Menu 1/2
> Band: High Ku/L-Band Freq.
L-Band Freq: 1388.00 (MHz)
FEC Rate: 3/4
Symbol Rate: 29.4730 (MS/s)
Polarization: H
Input select: RF

Bit Error Rate: 4.2E-3 LOCKED
Signal Level: 61
AFC Level: -1

Press CHAN. UP/DN to modify
Press NEXT to select
Press YES to store all data
Press USER to select page 2
  
```

"twisted" on its axis by an extra 10 degrees (a result of their misadventures during launch), you have to twist the PAS-8 feed 10 degrees out of true to maximise the cross pole nulling. This is essential if you want to keep the PAS-2 opposite polarities from beating each other to death. And this makes the entire assembly just a little "tight" to adjust. We suspect for some locations, "very difficult" would better describe "tight."

We were shorted bolts, the hardware was not stainless as we had requested, and the paint job was second rate. But PanAmSat handled the supply and shipping beautifully and the antenna works great!



# Digital power, but how much?

As most digital Television signals have wider bandwidth than the typical 1MHz measurement bandwidth of a TV measuring instrument, using an analogue instrument to measure the power of digital TV transmissions has been a science lacking in precision, until now.

Unaohm has developed an automatic Digital Channel Power measurement system. The user marks the limits of the channel to be measured and then the instrument quickly makes a large number of power measurements across the channel, from which an effective average is calculated, and displayed in a digital format.

The new EP318 from Unaohm offers a wide range of standard analogue and digital TV measurement functions with precision Bit Error Rate measurement options.

If you want instrumentation that can keep you in touch with what is really happening in your systems, consider Unaohm. From more than 60 years experience in the manufacture of electrical measurement instruments and a leading position in the development of DVB compliant digital TV measurement tools, Unaohm is now the choice of TV installers and TV spectrum management agencies the world over.

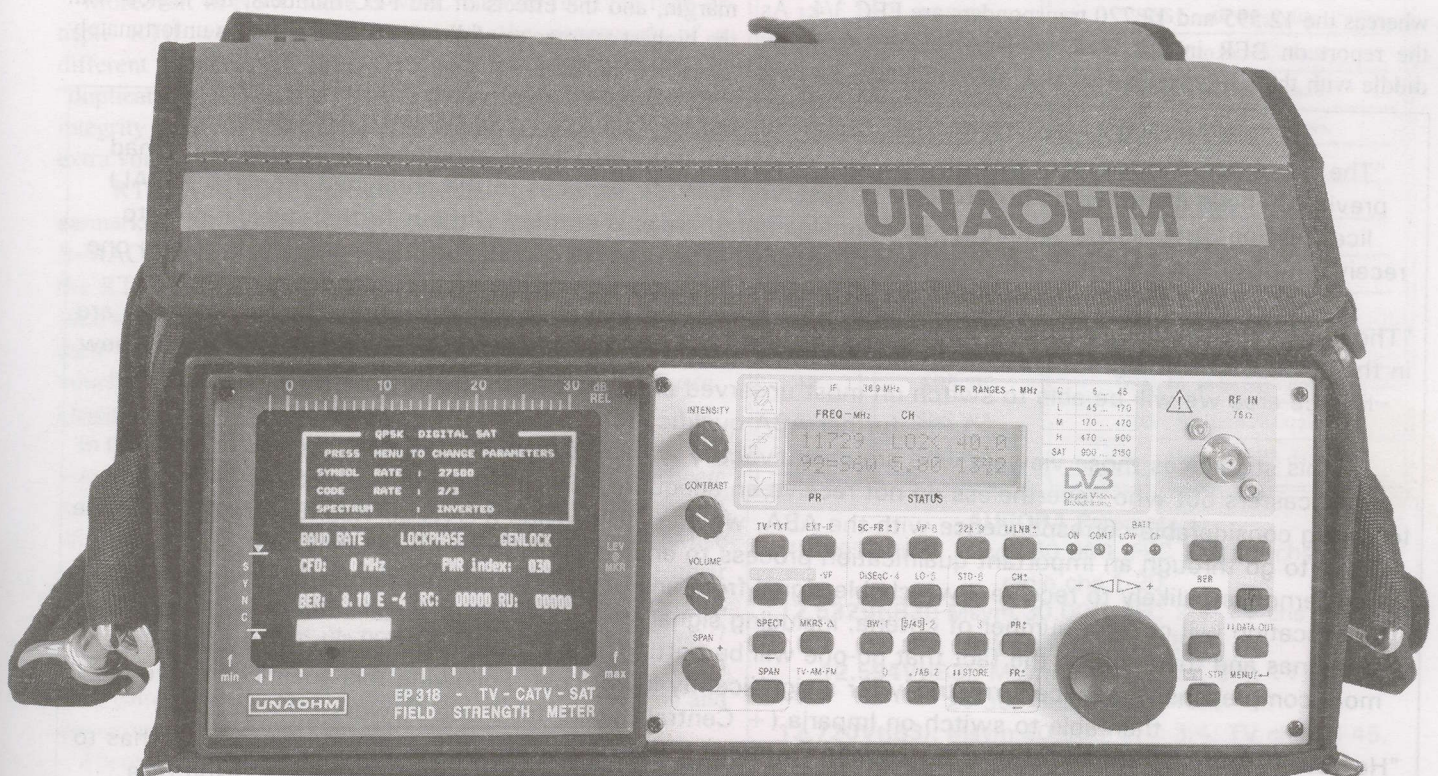

Technical Catalogue available now!

**Lacey's**  
Australia ACN 006 893 438

12 Kitson St. Frankston VIC 3199  
Tel:(03) 9783 2388 Fax:(03) 9783 5767  
Int+613 9783 2388 Int+613 9783 5767  
e-mail: placey@netlink.com.au  
Branches in Sydney, Ulverstone & Woolgoolga



## RTIF Where It Went Wrong

SatFACTS has asked our "Email Advisory List" of readers to take a few minutes to read the carrier to noise levels (C/NR) they see on the four Aurora transponders (12.407, 12.532, 12.595 and 12.720) as well as the four Austar/Foxtel pay-TV transponders on the horizontal side (12.438, 12.564, 12.626 and 12.688). If you are not an Email "reader," we ask you as well to do this (results can be Emailed to us at Skyking@clear.net.nz).

Early numbers suggest that while the horizontal transponders are even in level (+/- 1 dB typically) at virtually all locations tested to date, there are some very significant differences on the vertical side. At some locations, 12.407 and 12.720 are many dB (as many as 6) higher in level than the other two (12.532, 12.595). By putting together a wide geographic region analysis (hopefully stretching from Perth to New Zealand), we hope to be able to pinpoint some of the "trouble areas" which to date have not been properly explained by Optus.

So who made the various technical decisions affecting the Aurora project at Optus? And are these decisions cast in concrete, not subject to change?

The 12.407 and 12.532 Aurora bouquets use an FEC of 2/3 whereas the 12.595 and 12.720 transponders are FEC 3/4. As the report on BER in this issue explains (p. 6), when you diddle with the BER, you are creating new minimum antenna

sizes for at-threshold reception. If using FEC 2/3 an Aurora transponder is right at threshold, changing the FEC to 3/4 means you have to increase the gain (size) of the antenna by 1.0 dB. To put that another way - the 12.407 and 12.532 transponders will work to smaller antennas, and have a better rain fade margin than the two upper transponders on a given dish of any size. Why would Aurora deliberately select two separate FEC rates which directly affects relative performance between the four transponders?

One possible reason is their planned transponder loading. As you increase the FEC, you can squeeze more compressed material into the transponder. To put that another way - Optus management can potentially get more revenue from an FEC 3/4 transponder than from an FEC 2/3 transponder.

The FEC 2/3 transponders carry the Sky Racing Channel services, ABC-SE and the SE and WA SBS channels. Services on these two transponders will be "most robust" when it rains, least complex to dish-align (because of the extra 1 dB of margin or headroom). Note that at the present time, 12.532 is also the lightest loaded of the four (there is room here for additional, future service channels).

If we look at the four transponders in terms of rain fade margin, and the effects of the FEC numbers, the region with the highest average rainfall rates (Queensland) is unfortunately delivered at FEC 3/4.

### BREAKTHROUGH - Terrestrially Deprived Homes Gain Access to National Networks

"The recent amalgamation of Imparja and TAL's licence areas also added a number of locations that had previously been identified as unserved or undeserved with TV services to the combined (Imparja + TAL) licence area. Any viewer within the new amalgamated areas is entitled without further qualification to receive Imparja and Central Seven commercial services. The process of defining these areas was a long one and involved feedback from all of the current commercial television licensees.

"The new combined licence area is defined in terms of collection districts based on the 1996 census. We are in the process of turning this 'raw data' into a licence area map and community database. Based on the new licence area we will be able to switch on most unserved and undeserved viewers without any need for further ABA qualification.

"This still leaves those viewers who are unequivocally within the licence areas of other commercial broadcasters but who nevertheless do not receive an adequate service. Under these circumstances, and following considerable correspondence with the ABA, we can still provide a DTH service. Before doing so we need to go through an important qualification process to enable the ABA to be satisfied that the viewer concerned is unlikely to receive a watchable signal from any of the commercial terrestrial services. This qualification will cover a number of criteria, including signal strength, cost of installation of large receive antennas and towers, and the fact that no-one will be putting in a \$1500 satellite dish if they can get a more comprehensive service terrestrially for a significantly lower cost. Following this qualification we are then able to switch on Imparja (+ Central Seven) for those viewers.

"However even where there is clear qualification in these areas, there has to be a caveat. The viewer has to accept that should a terrestrial service subsequently become available (for example, as a result of a community self help scheme), then the commercial satellite service will be immediately withdrawn. Of course the viewer will still be left with satellite reception of ABC, SBS, and narrowcast services including a range of radio services.

"Based upon the above, we will be happy to deal with applications from both viewers and dealers on a case by case basis."

Tim Mason, Chief Engineer, Imparja Television Pty Limited

PO Box 52, Alice Springs, NT 0871  
tel 08-8950-1450; fax 08-8953-0322



### Another Number Question

How many RTIF vouchers is / was each family entitled to? The answer may be more complex than you think. Each registered B-MAC decoder was entitled to an RTIF \$750 subsidy voucher. In the great majority of cases, one B-MAC decoder to one family. But there are / were exceptions to this.

Some multiple TV set families had more than one B-MAC unit. And they were therefore entitled to as many vouchers (and UEC 642 IRDs) as they had B-MAC units to take out of service. Unfortunately, there were also some quantity of non-operating B-MAC units which had collected through the years in people's garages, under work benches in warranty repair stations. And some people figured out that these old "boat anchors" were suddenly "worth \$750" as trade-ins for UEC 642 units.

Normally the non-working B-MAC units would not have routinely appeared on broadcaster viewer files. Each broadcaster was supposed to ensure that only authorised and operating B-MAC viewers would receive RTIF vouchers. But some clever (or devious) people managed to get non-working B-MAC units into the queue for RTIF vouchers and by this simple ploy a quantity of UEC 642 units got into the field as "spares" - IRDs that cost the person involved in the grey market act a few hundred dollars rather than the standard fee close to A\$1000.

Sooner or later these "new-in-inventory" units became commodities in commerce. For typically A\$250 "cost" someone had a UEC 642 valued at A\$995 and the opportunity to resell it at a handsome mark-up.

Moreover, in NSW some B-MAC viewers received twin or triple RTIF vouchers - each through the paperwork of a different broadcaster. SatFACTS has seen examples of the "duplicate RTIF vouchers" from dealer-readers who had the integrity to advise their customers to turn back in, unused, the extra voucher(s).

RTIF vouchers represent federal government money earmarked for a specific purpose. When non-functioning B-MAC units got into the queue for new IRDs, the integrity of the RTIF programme was violated. If you have examples of such shenanigans and proof that people have by accident or by their own actions managed to end up with two or more vouchers, we'd like to hear from you. *In confidence, of course.*

### Discussion of Imparja's Initiative

In the March issue, we reported a plan to allow terrestrial TV viewers who are unable to receive off-air TV of adequate quality (or quantity) to be "turned on" via satellite. The root of this has been the approval by the A.B.A. of Imparja (Alice Springs) and TAL/QQQ (Queensland) consolidating their respective service areas into one combined region. This "amalgamation" makes it possible for viewers to have 7 Network service (TAL/QQQ, now known as Central 7) and 9 + 10 (through Imparja) in addition to ABC, SBS, Horizon and numerous radio service channels.

There was one major hurdle to be crossed; the A.B.A. which believed (in late February) it as an agency would have to approve each and every single home application for Imparja + Central 7 service - if the homes were located outside of the amalgamated region.

We reported on the prospect that any home, anyplace except in Western Australia, could be turned on for the national network package, and described in detail how as a satellite dealer you might get your customers "qualified" for this package (March p. 1, 20, 32). The basic criteria for approval

## AURORA TV Channels - as of April 8, 1999

1	TVSN	FTA/Television Shopping Network
2	HORizon	Horizon Learning Channel
3	(not in use)	
4	BTV1	enc/Xcept Tues 0920-1200 UTC
5	BTV2	enc/Optus Business TV
6	BTV3	enc/occ. labelled "Optus @ttitude"
7	Sky 1	enc/normal Sky racing service
8	Sky 2	enc/Sky + NSW TAB radio
9	Sky 3	enc/Sky + Vic TAB data
10	Sky 4	enc/Sky + WA TAB radio
11	Sky 5	enc/ Sat Comms
12	Sky 6	enc/ (new March 29)
13-20	not in use	
21	ABC TV WA	Public TV. Western Australia
22	GWN TV	WA only, 9 & 10 networks
23	WLK	Westlink (WA Education)
24	WIN	WA only, 7 network
25-28	scrambled	
29	ABC TV NT	Public TV. NT
30	IMP TV	see p. 14 here, 9 + 10 networks
31	IMP PTTV	enc/business (0889-501-411)
32-35	scrambled	
36	ABC TV SA	Public TV. SouthAustralia
37	SBS SA	SBS South Australia
38	SBS SA	// to 37; to be SBS data
39	ABC TV Q	Public TV. Queensland
40	Seven Central	see p. 14 here; 7 network
41	SBS Qld	SBS Queensland
42	SBS Q data	// to 41, to be SBS data
43	(test)	temp audio channel 51
44	(test)	temp audio channel 51
45	ABC TV SE	Public TV. Sydney (southeast)
46	SBS SE	SBS, Sydney (southeast)
47	SBS SE	// to 46, to be SBS data
48	SBS WA	SBS, Western Australia
49	SBS WA	// to 48, to be SBS data

### AURORA Parameters

- 12.407Vt(B3).** Msym 30.000, FEC 2/3; TV chs 1-20, radio chs 1-20
- 12.532Vt(B3):** Msym 30.000, FEC 2/3; TV chs 46-49, radio channels 64-66
- 12.594Vt(B3):** Msym 30.000, FEC 3/4; TV chs 21-35, radio chs 21 - 44
- 12.720Vt(B3):** Msym 30.000, FEC 3/4; TV chs 36-45, radio chs 45 - 63

### Aurora Notes

On non-Aurora receivers, TVSN (TV ch 1), radio chs. 20, 21 are FTA. SMA radio chs 1-7 may show CA but are rarely muted. DGT-400 IRDs will NOT work on Aurora even with card. National 7 is now carried by Central 7 (TAL/QQQ) and GWN; GWN is also available on PAS-2 Ku using PowerVu. National 9 and 10 are carried by Imparja and WIN.



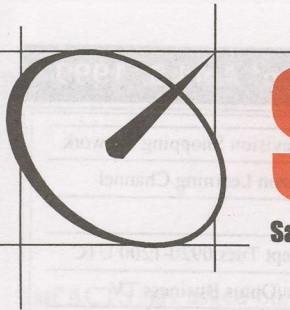

# SATECH

Satellite Communication Technology Pty. Ltd.



## Phoenix 333

**"THE BENCHMARK IN A NEW GENERATION"**



### Phoenix 333

As quoted in November Issue of SatFACTS

*"If we were forced to make a decision between owning any digital and any analogue receiver we would decide on owning the Phoenix 333"*

3 in 1 Digital-Analogue-Positioner

High Sensitivity on Digital

Low Threshold on Analogue

Heavy Duty Power Supply for Positioner



## Phoenix 111

**"REVOLUTIONARY IN COST AND PERFORMANCE"**



### Phoenix 111



**Power Supply and Software  
Specially Designed for  
Australian Conditions**

Digital

High Sensitivity Loop through Tuner

Built in Digital NTSC to PAL Converter

Heavy Duty Power Supply



Solo distributor for Phoenix Worldwide



# SATECH

Satellite Communication Technology Pty. Ltd.

Head Office: 6/477 Warrigal Road Moorabbin East Victoria Australia 3189 Ph: 61 3 9553 3399 Fax: 613 9553 3393



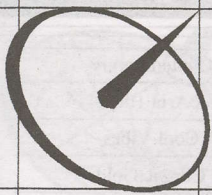

# SATECH

Satellite Communication Technology Pty. Ltd.

**cables** Times Fibre & Comscope

Huge range of  
RG6 & RG11

- Dual
- Quad
- Flooded
- Messengered

also 7 core tracking  
system cable  
(available by reel or per meter)

**RG 6  
DUAL  
\$99.00**



## One Stop Shop

- Receivers
- Dishes
- Cables
- Fly Leads
- Wallplates
- Feedhorns
- Lnbs
- Tools
- Tape
- Poles
- Decktite

**SATECH**  
Distributors  
for the  
Full Range of  
**PARACLIPSE**

## SATECH Distributors for the Full Range of CALAMP

- CALAMP C BAND 25K VOLTAGE SWITCHING LNBF
- CALAMP KU BAND 1dB PRIME FOCUS VOLTAGE SWITCHING LNBF
- CALAMP KU BAND 1dB OFF-SET VOLTAGE SWITCHING LNBF
- CALAMP C BAND DIGI-READY PHASE LOCKED LOOP 25K LNB
- CALAMP C BAND MINI-MAG 17K LNB
- CALAMP C BAND MINI-MAG DIGI EXTENDED 20K LNB
- CALAMP KU BAND 0.8 dB LNB
- CALAMP KU BAND 1dB HIGH STABILITY LNB
- CALAMP C BAND EXTENDED PROFESSIONAL II LOW PHASE 20K
- CALAMP MMDS INTEGRATED ANTENNA

**Also available Cyclone 2.3m mesh dish**

- Easy to Install
- Reliable
- Cost effective

**\$399.00  
Ex Tax  
Plus Freight**

**All products available through the following SATECH Distributors:-**

Southern Satellite - South Australia -Tel: 08 8377 0955

Network Satellite Services - NSW -Tel: 02 9687 9903

Satech - Head Office Melbourne Victoria -Tel: 613 9553 3399

**SPECIAL  
of the  
MONTH**

**PALCOM**



**PALCOM SL-7700RP features**

- Dual Axis
- Positioner
- Low Threshold
- Auto Focus
- Inclined Orbit tracking

## dishes

**SATECH your No.1 Paracclipse distributor  
for the complete Paracclipse range**

**Paracclipse Dishes**

- Exceptional strength and wind resistance
- Accurate reception

**WHEN  
QUALITY  
COUNTS**



**Paracclipse**  
HIGH PERFORMANCE ANTENNAS



would be proof that even with installation of a tall mast terrestrial aerial plus masthead amplifier, the home in question could still not receive "adequate" service from terrestrial transmitters. We also pointed out that typically 10% of all locations inside of a terrestrial station's coverage zone have inadequate or no reception because of local terrain factors.

As the advisory from Imparja's Tim Mason (see p. 14) clearly states, there is now a step by step system leading to approval of Imparja + Central 7 service for any home located anyplace in Australia with the exception of Western Australia (which in theory has the same level of service available through GWN and WIN). This is a very important step for disadvantaged terrestrial viewers, for satellite system dealers, and for hardware suppliers.

Nobody has ever properly measured the actual number of disadvantaged viewing locations in Australia. It is not unreasonable to expect it would surpass 50,000 homes. That number, by the way, is slightly less than 1% of all homes in Australia.

What this means to every dealer reading these words is as follows:

1) If you can identify homes in your trading region which are forced to either go without terrestrial reception or must endure degraded reception, you now have something to help them solve this problem.

2) Working with Imparja, you can "qualify" these homes for satellite reception.

3) And once qualified, you can install a suitable IRD (Panasonic TU-DS10, UEC 642 at this point in time) system.

It should be obvious that 50,000 terminal systems at A\$2,000 each add up to a bit of new business for this industry. The answer is A\$100,000,000. Or to put it another way, if there are 500 installing dealers out there who make it their business to take advantage of this opportunity, it works out to 100 new terminal sales per dealer, two-per-week for the next year.

Of course Imparja and Central 7 benefit from all of this activity. Every new viewer becomes an incremental improvement in their advertising reach, which ultimately means the stations are able to secure more dollars for their advertising which translates to more and better programming.

We don't know exactly what Imparja had to do to "*work this out with the A.B.A.*" but you can be sure that when other broadcasters see the potential here, there will be new commercial moves to compete with the Imparja initiative. And the Aurora project, even with its mistakes, could actually end up being a success after all. Such are the wonders of modern telecommunications.

#### RABS/RTIF Additional Information

Home DTH systems qualifying for the A\$750 RTIF voucher must select the UEC 642 IRD. Non RTIF users may choose between Panasonic TU-DS10 and UEC 642. Radio, TV ch consecutive numbers not shown are not in use at this time. Radio channels listed (right) with reverse numbers can be authorised (1300-301-681). Imparja can authorise for itself and Central 7 (1300-301-683). ABC, SBS TV authorisation - call 1300-301-681. SMA radio channels if not functional - 1300-366-099. WIN (west) 08-9442-3314. Also see p. 21, SF#54 and p. 18, SF#55 for additional listings.

1	R1	SMA Contemporary
2	R2	SMA Aria 100
3	R3	SMA Cool Vibes
4	R4	SMA Classic Gold
5	R5	SMA Country Beat
6	R6	SMA High Energy
7	R7	SMA Rock Radio
8	SMA BUS1	enc/Woolworths
9	SMA BUS 2	enc/ unknown content
10	QTAB	Queensland TAB
11	NIRS	enc/Indigenous Radio/07-3252-1588
12	RPH	enc/Print Handicapped Radio
13	BBC WS	enc but available/02-9955-4092
14	CBA A	enc/Community Broadcasters
18	UCB	enc but available/1800-068-204
19	SMA ITA	Radio Italia-SMA (FTA - temp?)
20	REF TONE	Reference test tone
21	RABS TONE	Deviation test (-18dB, 400 Hz. dual)
22	ABC FM WA	Classical for WA
23	ABC RN WA	Special Information for WA
24	ABC RR WA	Regional Radio for WA
25	990 AM	enc/Sight Impaired Radio
27	enc.	was JJJ: now unknown
28	enc.	was ABC PNN. now unknown
32	ABC FM NT	Classical for NT
33	ABC RN NT	Special Information for NT
34	ABC RR NT	Regional Radio for NT
35	IMP R1	8KIN Alice Springs-Imparja users
36	IMP R2	TEABBA Darwin- Imparja users
37	IMP R3	5PYM Umuwa - Imparja users
38	IMP R4	TAB NT - avail only in NT
39	IMP R5	not in use
40	IMP R6	not in use
41	IMP R7	enc/ unknown content
45	ABC FM SA	Classical for SA
46	ABC RN SA	Special Information for SA
47	ABC RR SA	Regional Radio for SA
48	SBS R SA	SBS National for SA
49	(test)	temporarily same as 45
50	(test)	temporarily same as 45
51	ABC FM Q	Classical for Queensland
52	ABC RN Q	Special Information for Queensland
53	ABC RR Q	Regional Radio for Queensland
55	SBS R QLD	SBS National for Queensland
56	ABC JJJ	enc but available 1300-301-681
57	ABC PNN	enc but available 1300-301-681
61	ABC FM SE	Classical for South East
62	ABC RN SE	Special Information for South East
63	ABC RR SE	Regional Radio for South East
64	SBS R SE	SBS National for South East
65	SBS R NT	SBS National for NT
66	SBS R WA	SBS National for WA



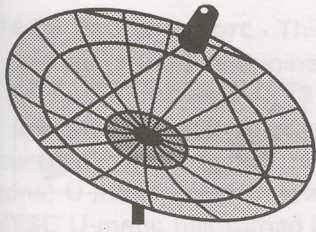

# AV-COMM SATELLITE TV EQUIPMENT

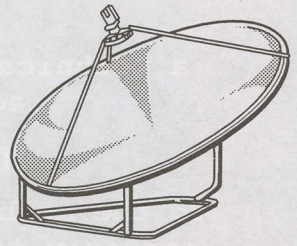

## FREE TO AIR DIGITAL SATELLITE RECEIVER R3100

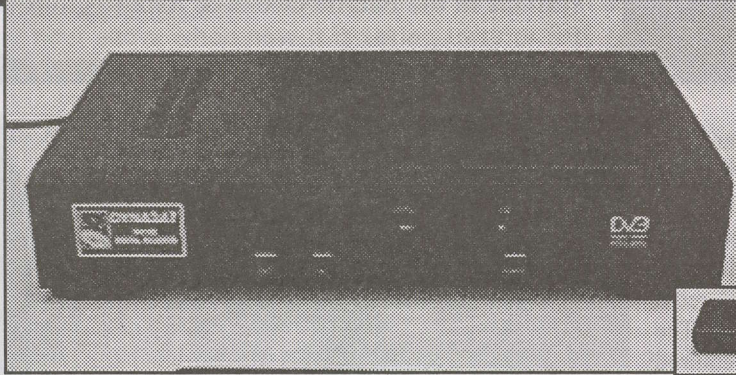

Cat # R3100

**ONLY**  
**\$1145**

Call  
for  
export  
price

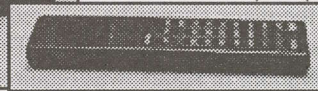

### FEATURES

- ◆ 950-2150 extended frequency coverage, C & K band
- ◆ 14/18V LNB polarity selection
- ◆ MCPC & SCPC
- ◆ 22KHz tone switching for dual input ops.
- ◆ Downlink signal margin indicator
- ◆ Dual channel audio
- ◆ Channel "edit" facility
- ◆ 0-12V output for dish selection
- ◆ S-VHS video output
- ◆ Auto FEC detect

## DYNALINK MANUAL TUNED RECEIVER R1100

### SPECIFICATIONS

- ◆ 950 - 2050MHz IF Input range
- ◆ Low threshold operation
- ◆ Stereo audio
- ◆ 14/18V LNB switching
- ◆ 18/27MHz IF Bandwidth.

Ideal for band scanning, channel monitoring, or as the heart of any home satellite receiving system.



**ONLY**  
**\$199**

Call for  
export price

Cat # R1100

## AV-COMM PTY. LTD.

DIRECT IMPORTER ACN 002 174 478  
PO BOX 225, BALGOWLAH 2093

TEL: 61 2 9949 7417 9948 2667

FAX: 61 2 9949 7095

VISIT OUR WEB SITE AT

<http://www.avcomm.com.au>

\*We reserve the right to improve product performance without notice.

✓YES GARRY, Please send me more info...

Name: \_\_\_\_\_

Address: \_\_\_\_\_

\_\_\_\_\_ P'code: \_\_\_\_\_

Phone: \_\_\_\_\_



a technical and marketing  
advisory

## memo

to the membership from your  
industry trade association

## SPACE Pacific

Satellite  
Programme  
Access  
Committee



A trade association for users, designers,  
installers, sellers of private satellite-direct  
systems in the Pacific Ocean & Asia Regions

### Fun 'n Games at SPRSCS '99

The group was small and one very important participant was missing. But if we'd had just a few more there, it could have been chaos.

Christian Mass (Dr Dish of Germany's Tele-Satellite magazine) departed Holland and flew on Korean Airlines to Seoul to change planes. During the plane change he suffered a heart attack and was quickly placed under a doctor's care. The doctor decided a few days observation, in Korea, was required and then Christian was returned to Holland on a return Korean Air flight. He never made it to New Zealand and as a consequence we were forced to reschedule and redo our two days of videotaping less his important presence.

For the new comers, SPACE Pacific is creating a series of television programmes (SPACE Pacific Reports) which will air first on AsiaSat 2's KIBC and later on Intelsat 701's SPN. The programmes, one hour in length, will also air in Europe through the "Dr Dish" TV programme (3 hours in length, once per month). We saw in the combining of the European DTH industry and the Asia-Pacific industry an opportunity to share technology, problem solving, and an exchange of dealer/installer/user views on a global basis. This will go ahead less the New Zealand participation of Christian Mass who was - of course - greatly missed. Word the Christian was stopped in Seoul arrived less than 30 hours before the first TV shoot was scheduled - resulting in a massive redo of scripting plans at the last minute to work around his absence. You will be the judge of how it turned out when you see SPACE Pacific Reports on KIBC or SPN later this year.

#### Robin Colquhoun and Dr Overflow

Anyone who is into Nokia receivers knows about the software programmes created in Europe under the banner of "Dr Overflow." This software, installed in a suitable PC which is full-time connected through the RS232 port on the Nokia

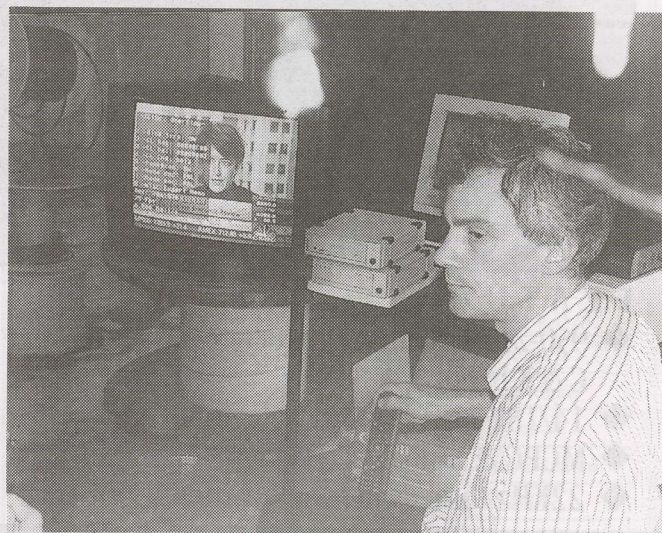

WORLD of Dr. Overflow - explained by Robin Colquhoun during SPRSCS '99 Conference. His videotaped discussion of Dr Overflow software for Nokia IRDs will (hopefully!) be on satellite during June.

IRD, takes over all operations control of the Nokia and adds a fantastic array of new search and analysis options which the standard Nokia software does not do. Not a few SatFACTS readers have obtained Dr Overflow software from Internet (it is primarily available free of charge although contributions to the multi-talented team of creators are gratefully accepted).

Robin Colquhoun of Auckland (NZ) is one such person. He has been encouraging SatFACTS to run a special "Dr Overflow" issue to tell you all of the wonderful tricks of this software; we have resisted. After Robin conducted a

## MEMBERSHIP IN SPACE

Membership in SPACE Pacific is open to any individual or firm involved in the "satellite-direct" world in the Pacific and Asia regions. There are four levels of membership covering "Individuals," the "Installer/Dealer," the "Cable/SMATV Operator," and the "Importer/Distributor/Programmer."

All levels receive periodic programme and equipment access updates from SPACE, significant discounts on goods and services from many member firms, and major discounts while attending the annual SPRCS (industry trade show) annually in New Zealand. Members also participate in policy creation forums, have correspondence training courses available. To find out more, contact (fax) 64-9-406-1083 or use information request card, page 34, this issue of SatFACTS. Page space within SatFACTS is donated each month to the trade association without cost by the publisher.



### STATUS - Various "Staying in Touch" Projects

**SPACE Pacific Report** - This is the current "major" project; the one that seems to be growing exponentially in time required. The original concept was simple enough - with more than 300 hours of videotape shot and produced between 1979 and 1990, detailing everything you ever wanted to know about DTH system design, installation plus equipment design - it seemed like a piece of cake to transfer this material to a suitable PAL format for telecasting through KIBC on AsiaSat 2. Problem one: There are very few (almost none) U-matic 3/4 inch low or high band NTSC players in New Zealand. To get the original material off of NTSC U-matic has turned into a big time project. Problem two: Many of the old(er) tapes quickly clog the heads on the U-matic machines creating a need to constantly clean heads and make on the spot decisions which tapes cannot be used after all (some really great ones simply won't play after nearly twenty years of storage). Problem three: Coping with a project that should have taken ten hours of work to reproduce each one hour show when now it is taking forty or fifty hours per show! The good news is that new tape shot during SPRSCS '99 is very usable and will likely run first when we finally hit the airwaves. When? See below.

**SPACE Pacific Web Site:** Is getting almost no attention at this time because of the pressure to get SPACE Pacific Reports TV shows edited and to KIBC. We'll advise.

**Email Advisories:** The second advisory went out to more than 900 addresses April 2 and gave detailed information on AsiaSat 3S testing. We are getting better at this and if you have not yet filed your Email address with us, do so now at [Skyking@clear.net.nz](mailto:Skyking@clear.net.nz). When the first SPACE Pacific Reports TV shows are finally in the hands of KIBC, we'll advise you through the Email service when to tune in.

descriptive explanation of what Dr Overflow is, and what it does, for the TV cameras during SPRSCS '99, we now know we made the right decision regarding devoting an issue of SatFACTS to this topic. It never would have fit! Moreover, unless you can see the on-screen changes as they take place during the presentation, it would be almost impossible to follow. The bottom line here is that television is the perfect medium for conveying highly complex step by step descriptive discussions of something like Dr Overflow. The down side is

that we will never get it into a single one hour programme for KIBC/SPN and we'll give you our solution to this in a future report.

SPRSCS '99 was a "television shoot" covering a wide range of practical, hands on topics you need to be conversant with as a dealer or installer. The project will benefit everyone in the industry through 1999 and beyond. A similar project is already in the planning stages for 2000. and the location of "the shoot" is likely to be extremely "unusual."

# ADI MediaMate

## Digital Satellite Receiver

**SPECIAL  
INTRODUCTORY  
PRICE** INCLUDES TAX

# ONLY \$695

CALL FOR EXPORT \$\$\$

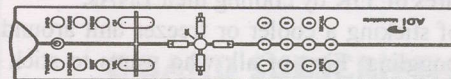

**DVB**  
Digital Video  
Broadcasting

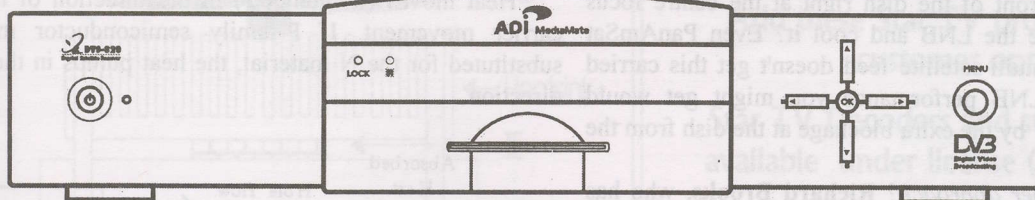

- Low Threshold Performance
- Easy to use Graphic Interface
- 2 - 32 Msymbols (FTA Power View)
- NTSC & PAL Outputs
- 22Khz / DiSeQ / 12VDC Aux
- Teletext Output in Video
- 90 - 264 VAC 47 - 63 Hz Power supply
- 27 / 36 Mhz Tuner
- PID Menu
- RS232 Computer Control & Software Download

Also Available 1.8m & 2.4m Solid Steel Dishes & MTI Dual Pol C Band LNBFs

**Pacific Digital Systems Pty Ltd Ph. 61 2 8765 0270 Fax. 61 2 8765 0275**

**EXCLUSIVE AUSTRALIAN, NEW ZEALAND, PACIFIC ISLANDS DISTRIBUTOR**



# The CABLE Connection

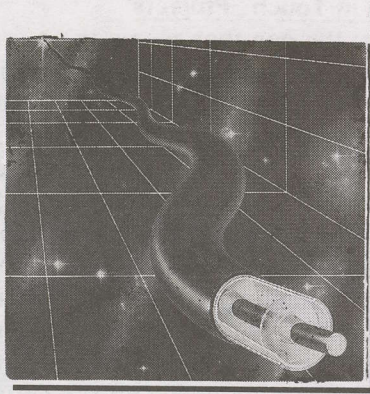

## Cool is "cool"

Most everyone knows that when an electronic circuit runs in a cool (as in low temperature) environment, it usually works better. Low noise amplifiers (LNAs), low noise block downconverters (LNBs) are no exception. Reduce the physical temperature of the LNB, the noise created by the device drops. When you purchase an LNB that claims a noise temperature of 20 degrees K(elvin) on C-band or 0.8 dB at Ku-band, this is typically rated for an ambient temperature of 68 degrees F. Anyone who lives where it gets cool (or cold) on a winter night has probably observed that the sparklie level on analogue service signals improves after sunset; directly attributable to the sun-baking of the LNB stopping and the unit cooling off.

Suppose you could artificially cool down your LNB - make it operate in a temperature zone that was 15 to 30 degrees C colder than the normal ambient level? Could you expect better pictures because of lower thermal noise in the LNB?

This concept has challenged, and puzzled, satellite system designers for decades. Early day LNAs operated inside of artificially cooled thermal boxes so their ambient (surrounding air) temperature seldom rose above 0C/32F. Those who have seen or will soon see the "[RCA Uplink Tour](#)" tape within the **SPACE Pacific Reports** TV series will notice a house-size air conditioning like unit built to cool off the LNAs in a special insulated room. In an era when LNAs never had noise temperatures better than 120K, RCA was routinely managing noise temperatures of 55K by cooling their LNAs.

The image of sticking a cooler or freezer unit around your LNB is mind boggling. First of all, who wants to stick a big chunk of metal in front of the dish right at the centre focus point just to enclose the LNB and cool it? Even PanAmSat with their PAS2-8 multi-satellite feed doesn't get this carried away! The better LNB performance you might get would quickly be "shunted" by the extra blockage at the dish from the air conditioning unit.

*So is there another approach?* **Richard Brooks**, who has designed and installed a 23 foot dish system for the Island of Roi-Namur in the Marshall Group of the Pacific, thinks there might be. While attending SPRSCS '99, Richard brought along the component parts and a technical outline suggesting how "*Peltier Effect Cooling*" might be able to drop the ambient operating temperature of an LNB very significantly, even when the LNB sits under a blistering dead-overhead Pacific Ocean sun.

## What is Peltier Effect?

Thermoelectric technology goes back to the 19th century. If you have two dissimilar conductors carrying electricity, at the junction of the two dissimilar conductors you will have either

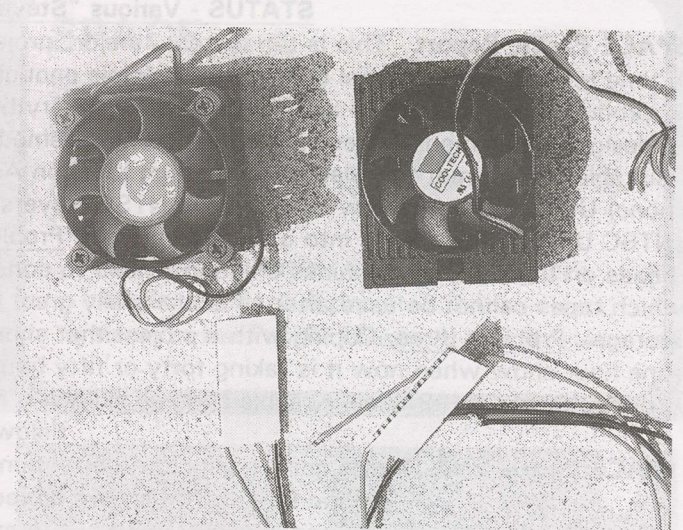

**SUPER cooled LNB?** The basic parts are here. How much better would your LNB work at a temperature near 0 degrees C or below?

the absorption of heat or the release of heat. By carefully choosing materials (such as Bismuth Telluride), a thermoelectric module can be constructed. This is the basis for the "heat pump" industry.

If 'N-type' semiconductor material is used to fabricate a "pellet" and if electricity is connected to the circuit as shown below, heat absorbed on one side (the bottom as shown here) is drawn or pumped through the N type material to the opposite pole where it is released.

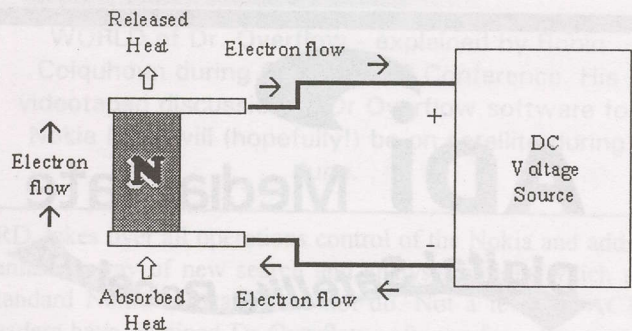

Heat moves (is 'pumped') in the direction of the charge carrier movement. If P-family semiconductor material is substituted for the N material, the heat pumps in the opposite direction.

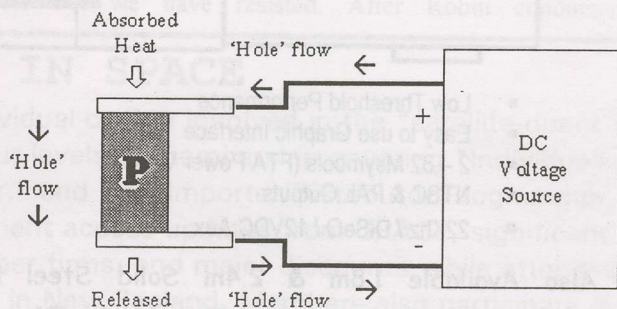

Each "pellet" (with either N or P material at the junction) will move heat. But not very much heat. So to increase the heat pumping capacity of a Peltier Cooler, a series of N and P pellets are strung together. If you look closely at the photo at



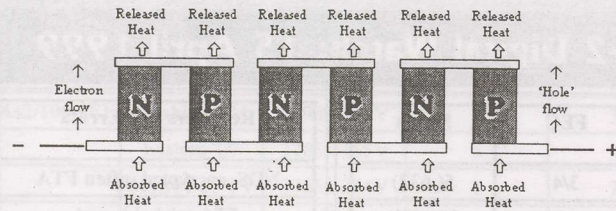

Multi-couple configuration increases heat-pumping capacity

the top of page 22, you can imagine each pellet as a segment of a larger Peltier Cooling device.

A "sandwich" of pellets represents a known quantity of heat pumping ability. And sandwich may prove to be an appropriate description of what an LNB equipped with a Peltier Cooling system might actually look like (see drawing at bottom of page). This is conceptual - at this stage - because neither Brooks nor anyone else has tried this particular approach to making an LNB work better at a cooled, artificial temperature.

There are some interesting physics problems here as we shall see next month. The heat you absorb from the LNB has to be distributed away from the LNB "zone" or you simply end up with cycles of cooling and reheating. So it is not enough to "grab" the heat from the LNB case, "move it" with the pump and then allow it to heat up some fins on an attached heatsink. And that explains the twin fans you see in the parts photograph on the preceding page.

Quickly in the space remaining. You are placing a Pellet array on each side of the LNB case. There are alternate approaches as we shall see in May. To move the heat away from the case, two sizeable "heatsinks" are attached to the Pellets and they are married to exhaust fans that move the heated air away from the vicinity of the cooled LNB. Brooks believes the system can be tested using tie-wraps and hose clamps as long as there is a clear path for the heat to follow as it is "sucked" away from the LNB. We'll see how in May.

A "practical" Peltier Effect cooled LNB has to do more than "suck" and "push" the LNB case heat. Heat drawn out of the LNB case must be dissipated (note the heatsink fins) and "moved" to get it away from the air envelope surrounding the LNB (otherwise you could end up reheating it all over again).

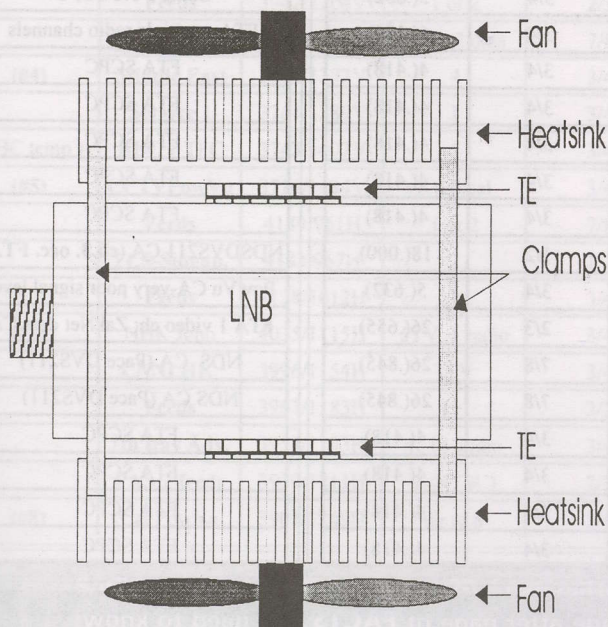

## New High performance low cost DVB free to air digital receivers- Hyundai HSS700 and HSS700A

HSS700 digital only with 1000 channel capacity, excellent on screen graphics, fast operation, and conversion at output to PAL or NTSC, both colour and scan rate! No more rolling on older style TVs!

HSS700A has the same features as the HSS700 with an additional 32 step LT analogue receiver built in. (No positioner.) Introductory prices-

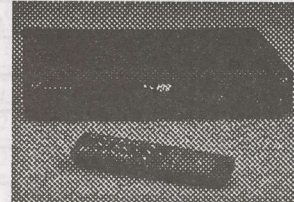

HSS700- \$A550  
HSS700A- \$A650  
Quantity discounts available

For full details see our home page- [www.kristal.com.au](http://www.kristal.com.au)  
All prices in Australian dollars ex-store in Townsville or Brisbane  
Australia plus freight and sales tax if applicable.

**KRISTAL**  
electronics

25 Cataract Ave,  
RANGEWOOD QLD  
4817. AUSTRALIA.

Tel. 61 (0)7 47888902 Fax. 61 (0)7 47888906  
Also available from *DALSAT Brisbane*  
Ph 61 (0)7 32646573, Fax 61 (0)7 32646539  
[www.kristal.com.au](http://www.kristal.com.au) [kristal@ultra.net.au](mailto:kristal@ultra.net.au)

**PUT STAR POWER  
ON YOUR SIDE**



**Star VIVA Cinema** (Filipino)

&

**Star India News** (Hindi & English)

**C-BAND SUBSCRIPTION TV!**

Add these Star TV programs to your customer options.

Star TV Decoders and subscription now available under license (Australia only).

**Inquiries sought from established, creditable satellite installers/retailers only.**

Please inquire to:

Bill Khan, **Solution 42 Pty Ltd**, PO Box 461, Ingleburn NSW 2560  
Ph 02-9820-5962; Fax 02-9820-1769  
Mobile 0411122 427



# SatFACTS Pacific/Asian MPEG-2 Digital Watch: 15 April 1999

BIRD	Service	RF/IF & Polarity	# Program Channels	FEC	Msym	
I703/57E	Sky News	4143/1007R	1	3/4	5(.632)	
	Occ. feeds	4055/1095L	1+	3/4	27(.500)	
	CNBC	4018/1132L	1	3/4	6(.000)	
	CNBC	3795/1355L	1	2/3	6(.000)	
I704/66E	TV5. Adult 21	4055/1095R	4	3/4	27(.500)	
	Sky News +	3805/1345R	4	3/4	22(.520)	
PAS4/68.5E	Nickelodeon +	4147/1003H	1 reported	1/2	24(.000)	
	BBC	3743/1407H	5	3/4	21(.800)	
	CCTV	3716/1434H	up to 6	3/4	19(.850)	
Ap2/76E	HMark/Kermt	3720/1430H	4	5/6	29(.270)	
	TVB-8 +	3849/1301H	4	3/4	13(.238)	
	Disney	3880/1270H	3	5/6	28(.125)	
	AXN	3920/1230H	up to 8	7/8	28(.340)	
	Vietnam	12.696V	1	3/4	3(.516)	
Them3/78.5E	ITC	3569/1581H	1	3/4	10(.200)	
	MRTV	3666/1484H	1	2/3	4(.442)	
	UTV	3920/1230H	6	3/4	26(.662)	
	UTV/MCOT	3880/1270H	8	3/4	27(.500)	
	Mahar./DDI	3600/1550H	up to 8	3/4	26(.662)	
	Myanmar TV	3666/1484H	1	3/4	4(.442)	
	TV Maldives	3412/1738V	1	1/2	6(.312)	
	Thai Global +	3425/1725V	up to 7	2/3	27(.500)	
	As2/100.5E	Chinese Tests	12.295.329H	1TV each	2/3, 1/2	6(.103/930)
		(#1) Euro Bouquet	4000/1150H	6TV, 12r	3/4	28(.125)
Hubei/HBTv		3854/1296H	1	3/4	4(.418)	
Hunan/SRTC		3847/1303H	1	3/4	4(.418)	
Guan./GDTV		3840/1310H	1	3/4	4(.418)	
Inn Mongolia		3828/1322H	2	3/4	4(.418)	
Saudi Arabia		3811/1339H	1	3/4	3(.095)	
APTN A-O		3799/1351H	1	3/4	5(.631)	
WTN Jer/Lon		3790/1360H	1	3/4	5(.631)	
WTN/Reuters		3775/1375H	1	3/4	5(.631)	
Reuters M-E		3770/1380H	1	3/4	5(.632)	
WorldNet		3764/1386H	1 + 20 radio	3/4	6(.100)	
Liaoning/Svc2		3734/1416H	1	3/4	4(.418)	
Jiangxi/JXTV		3727/1423H	1	3/4	4(.418)	
Fujian/SETV		3720/1430H	1	3/4	4(.418)	
Quinghai TV		3713/1437H	1	3/4	4(.418)	
Henan /Main		3706/1444H	1	3/4	4(.418)	
As2/100.5E		Sky Racing	4020/1135V	3	1/2	18(.000)
		EMTV	4006/1144V	1TV, 2radio	3/4	5(.632)
		KIBC	3940/1210V	1TV, 4 data	2/3	26(.655)
	STAR/ISkyB	3900/1250V	19TVw/3744	7/8	26(.845)	
	BSkyB	3865/1285V	8+	7/8	26(.845)	
	HeiLongJiang	3834/1316V	1	3/4	4(.418)	
	JSTV	3827/1323V	1	3/4	4(.418)	
	Shaanxi/QQQ	3813/1337V	1	3/4	4(.418)	
	Guang GXTV	3806/1344V	1	3/4	4(.418)	

Receivers and Errata
NDS encrypted; often FTA
FTA (global beam)
Feeds-FTA SCPC
Asia-Europe feeds-off air?
FTA (Adult 21 Sat 15.30UTC)/east
Sky News 24 hr, sport, feeds FTA?
Testing; also try 26(.000)
FTA; 2 audio channels?
FTA
PowVu typ CA
PowerVu CA
PowVu CA
Tests, promos, some FTA
FTA national service
FTA
FTA; difficult to load
Irdeto CA
Irdeto CA
FTA (Indian, Skai-TV)
FTA - may be only test
FTA (seen Australia)
FTA
FTA (mainland only beam)
FTA
FTA SCPC
FTA SCPC
FTA SCPC
FTA - #1 Chinese, #2 Mongolian
FTA SCPC - "Ch. 1"
FTA SCPC
Mostly CA SCPC, some FTA
Some FTA SCPC
Some FTA SCPC
FTA, multiple radio channels
FTA SCPC
FTA SCPC
FTA SCPC
FTA SCPC
FTA SCPC
NDS DVS211 CA (ch.3. occ. FTA)
PowVu CA-very poor signal level
FTA I video ch; ZakNet data CA
NDS CA (Pace DVS211)
NDS CA (Pace DVS211)
FTA SCPC
FTA SCPC
FTA SCPC
FTA SCPC



BIRD	Service	RF/IF & Polarity	# Program Channels	FEC	Msym
(As2/100.5E)	Fashion TV	3796/1354V	1	3/4	2(.533)
	Eastern TV	3785/1365V	5	3/4	18(.000)
	Myawady TV	3766/1384V	1	7/8	5(.080)
	STAR/ISkyB	3744/1406V	35TVw/3900	7/8	26(.845)
	Star TV Sports	3700/1450V	5	3/4	27(.500)
Cak1/107.1E	Indovision S-band	2.536, (.566, .596, 2.626)	38+	5/6	20(.000)
Sinoat 1/110E	Shanghai	4106/1044V	1	2/3	4(.443)
C2M/113E	Anteve	4193/957V	1	3/4	6(.508)
	TV Indosiar	4073/1077V	1	3/4	6(.500)
	Mega TV	3780/1370V	5?	3/4	27(.500)
	C Net Taiwan	3760/1390H	10TV, 10 r	5/6	21(.091)
	Ind/sion/.Star?	3580/1570H	7TV	7/8	26(.850)
	RCTI	3473/1677H	1	3/4	8(.000)
	API/138E	Taiwan Bqt	3800/1350H	up to 8	3/4
	MTV	3860/1290V	1	3/4	3(.000)
	Laos Nat. TV	3924/1226V	1	3/4	2(.522)
	CNNI	3980/1170V	2+	3/4	26(.000)
Optus B3/156	Aurora	12.595,.720V	17+, 21+ rad.	3/4	30(.000)
	Aurora	12.407.532V	17+, 21+ rad.	2/3	30(.000)
	Austar/Foxtel	12.438(.564, .626, .688)	45+TV, 12 radio	3/4	29(.473)
Optus B1/160	Sky NZ	12.391.(418)V	18TV	3/4	22(.500)
	Imparja feed	12.367H	1	3/4	5(.424)
PAS-8/166E	NHK Joho	4065/1085H	5 TV, 1 radio	3/4	26(.470)
	Cal Bqt/PAS8	3940/1210H	4 or 5 TV	7/8	27(.690)
	CNN	3780/1370H	up to 5	3/4	25(.000)
PAS-2/ 169E	GWN Perth	12.265V	6TV, 7 radio	1/2	16(.200)
	Telstra Bend.	12.300V	2	1/2	21(.997)
	ABC Interchange	12.629, (.638, .646)V	1 TV each	3/4	6(.980)
	Mediasat	12.655V	1TV	1/2 & 3/4	6(.610)
	(#2)	HK PowVu	4148/1002V	up to 8	2/3
(#3)	NBC HK	4093/1057V	5 typical	3/4	29(.473)
	JET Singapore	3962/1188V	2	1/2	13(.740)
	Feeds	3942/1208V	1 or 2	2/3	7(.497)
(#4)	ESPN USA	3860/1290V	7TV, 2 data	7/8	26(.470)
	Middle East	3778/1372V	4	3/4	13(.331)
	Service 1	3761/1389V	1	3/4	6(.620)
(BBC temp)	BBC + TFC	3743/1407V	5	3/4	21(.800)
(#5)	CCTVPowVu	3716/1434V	5 typical	3/4	19(.850)
	Feeds	4189/961H	1 or 2	7/8	6(.600)
	TCS-Singap.	4183/967H	2	1/2	6(.620)
(#7)	Feeds	4138/1012H	1	3/4	6(.620)
	NHK Joho	4035/1115H	5TV, 1 radio	3/4	26(.470)
	CNNI HK	3996/1154H	1TV	3/4	9(.998)
(#8)	Feeds	3967/1183H	1+	2/3	6(.618)
	7th Day Adv.	3957/1193H	1, 14 audio	3/4	7(.000)
	PAS-2 feeds	3939/1211H	2 (NTSC)	2/3	6(.620/7.498)
	Cal PowVu	3901/1249H	up to 8	3/4	30(.800)

Receivers & Errata
Temp FTA- see notes p. 6 Jan.
PowVu CA -#5 FTA: off-air?
FTA SCPC - difficult
NDS CA (Pace DVS211)
NDS CA (Pace DVS211)
RCA/Thomsom IRD. Now more dependable operation
FTA SCPC-difficult to load
Testing, FTA SCPC
FTA SCPC, maynot be permanent
unknown encryption format
all TV now CA
NDS CA
FTA SCPC
FTA MCPC
FTA SCPC
FTA SCPC
CNN FTA
CA, \$50 smart card required
CA, \$50 smart card required
DGT400 CA except #29 (TVSN)
NDS CA, 12.391 primary
may be temp feed to Aurora
ICA (D9234), 4 FTA
mixed CA + FTA (EWTN)
PowVu, poss. FTA 22/04 start
PowVu CA (D9234)
PowVu typ. CA (D9223 only)
format PowVu, nominally FTA: except 0000-0400UTC wkdays
FTA, occassional service. feeds
PowVu, mostly CA, some FTA
Philips mux format FTA
PowVu CA-June shut down
FTA occ. feeds
PowVu CA: avoid #8.9 w/9223!
FTA -hard to load
occ feeds, FTA SCPC
PowVu: CA and FTA (BBC#3)
FTA (# pgm chs varies)
Test cards, may be feeds
PowVu FTA/snews ch coming
FTA SCPC
1 CA (D9234), 4 FTA to 30/04/99
FTA - occasional feeds
FTA - occasional feeds
1900-2030UTC, not daily
FTA (NBA, shuttle-typ NTSC)
Some CA, some FTA ( NTSC)



## SatFACTS Digital Watch: Supplemental Reference Data / April 1999

PAS-2/169E	Disney	3804/1346H	3	5/6	21(.093)
	Discovery Sing	3776/1374H	8	3/4	21(.093)
	Satcom 1-6	3743/1407H	5	7/8	19(.465)
I702/177E	AFRTS	4177/973L	8TV, 12r.+	3/4	26(.694)
	Thai Bouquet	12.650H	up to 3 TV	1/2	17(.800)
I701/180E	TVNZ Gennet	4195/955R	1 (CA)	3/4	5(.632)
		4186/964R	BBC/Gennet	3/4	5(.632)
		4178/972R	1 (CA)	3/4	5(.632)
		4170/980R	APT-N-Tokyo	3/4	5(.632)
	AFRTS Pac.	4175/975L	3 radio	2/3	3(.679)
#9	RFO-Canal+	4095/1055L	7TV, 5+ radio	3/4	27(.500)
	SPN Nauru	4081/1069R	1	3/4	4(.730)
	NZ Prime TV	4024/1126L	1	2/3	6(.876)
(off air?)	Network 7	3966-2/1184L	1	7/8	6(.446)
	RFO direct	3858/1292L	1	3/4	4(.566)
	TVNZ TL	3854/1293R	1	3/4	5(.632)
	TVNZ	3856/1294R	1	3/4	5(.632)
	TVNZ	3846/1304R	1	3/4	5(.632)
	10 Australia	3765/1385R	6	7/8	29(.900)

PowVu (D9234) CA
PowVu (D9234) CA
recently Middle East (4 chs)
PowVu (D9234) CA
FTA, replaced Space TV
DMV/NTL CA, all channels occ. use, FTA irregular around special event coverage
PowVu, audio only (3 chs.)
Canal + (2) CA, rest FTA
FTA SCPC; weak signal
PowVu CA; network feeds
SCPC FTA NTSC f/USA
East hemi beam to Tahiti
SCPC mixed FTA, CA feeds
SCPC mixed FTA, CA feeds
SCPC mixed FTA, CA feeds
PowVu CA; #5,6 occ FTA

**Bouquets:** MCPC (multiple [program] channels per carrier) MPEG-2 content frequently changes. Primary FTA (free to air) MCPC bouquets are as follows: 1) **European Bouquet:** (1) **Deutsche Welle**, (2) **MCM**, (3) **RAI International**, (4) **RTVE** (Spain), (5) **TV5 Paris** + up to 17 radio (some stereo) - see p. 2 ; 2) **Hong Kong PowVu:** (5) **Ad Hoc NTSC feeds**, (6) **Ad Hoc PAL feeds:** (3) **NBC HK** (Hong Kong): (1) **CNBC Asial**, (2) **CNBC Australia**, (3) **National Geographic** [English], (4) **CNBC India**, (5) **National Geographic** [subtitled Taiwan], (6) **Occ feeds**, (7) **CNBC test card-feeds:** (4) **Middle East** [testing]; (1) **Antenne 1**, (2) **Lebanon LBC**, (3) **ART Australia**, (4) **RAI Australia**; (5) **CCTV PowVu:** (1) **CCTV4**, (2) **CCTV3**, (3) **CCTV 9**, (4) **test bar**, (5) **CCTV1**; (7) **NHK JoHo:** (1) **NTSC Japanese**, (2) **NTSC English**, (3) **PAL Japanese**, (4) **PAL English**, (5) **NHK Radio**, (6) **NHK Premium**; (8) **Cal PowVu:** (1) **CMT** [NTSC] (CA 01/07), (2) **Ad-hoc** [NTSC], (3) **BBC**[NTSC], (4) **EWTN** + Global Catholic Radio . (5) **Ad hoc feeds**, (6) **Bloomberg Financial** [NTSC], (7) **Golf Channel** [NTSC], (8) **Discovery**; (9) **RFO-Canal+:** (1) **Canal+** [Polynesia], (2) **Canal+** [New Caledonia], (3) **test**, (4) **test**, (7) **TOM1**, (10) **TOM2**, (13) **TOM3** + radio on 5,6,8,9,11,12,14,15.

### MPEG-2 DVB Receivers: (Data believed accurate; we assume no responsibility for correctness!)

**ADI MediaMate.** FTA, NTSC-PAL outputs. (Pacific Digital Sys. Pty Ltd, tel 61-2-8765-0270)  
**AV-COMM R3100.** FTA, excellent sensitivity (reviewed SF May 1998). Av-Comm Pty Ltd., tel 61-2-9949-7417  
**Grundig DTR1100.** Mfg by Panasat S. Africa, similar to Panasat 630; out of production, Irdeto capable (see AV-Comm. above)  
**Hyundai-TV/Com.** HSS-100B/G (Pacific) and HSS-100C (China) FTA. Versions 2.25/2.26 good performers. 3.11 currently offered and those with Nokia tuners good performers. Version 5.0 not so good. SATECH ([V2.26] 61-3-9553-3399), Skandia ([V3.11] 61-3-9819-2466); Skyvision Australia ([V3.11, Nokia] 61-2-6292-5850).  
**Hyundai HSS700.** FTA, PowerVu, search, SCPC/MCPC. (Kristal Electronics 61-7-4788-8906) [New February 1999; review March99]  
**MediaStar D7.** FTA, preloaded with known services, exc. software (review SF July 1998). MediaStar Comm. Int. (61-2-9618-5777)  
**Nokia "d-box" (V1.7X).** European, FTA, typically German menu, capable of "Dr. Overflow" Internet updates. Caution on this one!  
**Nokia 2000S (Asia/Pacific).** Released Oct. 1998; equipped with CAM/PCMCIA slot, capable of Irdeto, others (factory will NOT supply CAMs at this time); no Asia-Pacific sources known at this time (but readily available through European sources); review 11/98.  
**Nokia 9200/9500/9600/9800.** FTA, factory software does PowVu poorly, but has significant Internet software support. Ultimate play-around hobby machine but not consumer friendly. Original V1.63 had unique ability to search entire satellite to locate and list all SCPC/MCPC services; latest (V5.X software) versions compatible with Dr. Overflow (V8.X) software from Internet. CI (common interface) versions available in Europe, do not presently allow Irdeto however. No Pacific/Asia support; help from Av-Comm (61-2-9949-7417), and software from [www.BAKKERELECTRONICS.COM](http://www.BAKKERELECTRONICS.COM).  
**PACE DVS-211.** NDS CA only (no FTA); Sky Racing (As2), Indovision, others. (Sky Racing - Eileen McCarthy 61-2-9451-0888)  
**PACE DGT400.** Original Galaxy (now Foxtel Sat/Austar) IRD, Irdeto, FTA with difficulty. (Foxtel Australia 1300-360818).  
**PACE DVR500.** Original NBC affiliate IRD; FTA or Irdeto (w/CAM). Similar to DGT400, more reliable. No sources.  
**PACE "World Box."** (DSR-620) Created for NDS non-DVB compliant MPEG-2, including Sky NZ. Info, ++49-211-526-9833.  
**Panasat 520/630/635.** MCPC FTA, Irdeto capable. Out of production; spares from UEC (fax ++27-31-593-370, Russell Futter).  
**Panasonic TU-DS10.** FTA, Irdeto CA. (see SF Aug. 1998). Aurora, (Evcom 61-2-9316-5055),  
**Phoenix 111 & 222.** FTA, PowVu. Exceptional graphics, ease of use. (SATECH 61-3-9553-3399)  
**Phoenix 333.** FTA MPEG-2, analogue, positioner. Detailed review SF Nov. 1998. (SATECH 61-3-9553-3399).  
**PowerCom.** FTA, PowVu, exc. sensitivity. (NetSat 61-2-9687-9903)  
**PowerVu /PowVu D9223, 9225, 9234).** Non DVB compliant proprietary format capable MPEG-2 FTA with optional software. 9234 sold for GWN and NHK Joho PAS-2, EMTV As2, CA access; others for various CA services. (Scientific Atlanta 61-2-9452-3388)  
**Praxis DigiMaster 9600 MKII/9800AD.** FTA, PowVu + analogue., (no longer supported in Pacific)  
**Praxis 9800 ADP.** FTA, PowVu, analogue, positioner. Review December 1998. (no longer supported in Pacific)  
**Prosat 2102S.** FTA, NTSC + PAL, SCART + RCA. (Sciteq 61-8-9306-3737)  
**SatCruiser DSR-101.** FTA, PowVu, NTSC + PAL. (Skyvision Australia 61-2-6292-5850; Telsat 64-6-356-2749)  
**SatCruiser DSR-201P.** FTA, NTSC & PAL digital, analogue, positioner. (Skyvision Australia - see above)  
**SK888.** (aka DigiScan from Sun Moon Star). FTA MCPC, Irdeto CAM capable. (Skandia 61-3-9819-2466)  
**UEC 642.** FTA, Irdeto built-in, for Aurora + Optus DTH. ("Mondec" rack mount industrial version) (Nationwide 61-7-3252-2947)  
**UEC 660.** Primary user is Australian Sky Channel; not consumer item (info from but not available at Nationwide 61-7-3252-2947)  
**YURI HSS-100C.** FTA, rebadged Hyundai V.2.27 software custom to Australia (Nationwide 61-7-3252-2947)



# SatFACTS Pacific/Asian FTA ANALOGUE Watch: 15 April 1999

Copyright 1999: SatFACTS, PO Box 330, Mangonui, Far North, New Zealand (FAX 64-9-406-1083)

BIRD / Location	RF/IF & Polarity	Service	Errata	
<b>I703/57E</b>	3755/1395R	Sun Music		
	3798/1352R	RTNC		
	3980/1170R	AsiaNet		
	4055/1095R	WorldNet	VOA subcar.	
	4125/1025R	TVi		
<b>I704/66E</b>	4175/975L	Muslim		
	3765/1385R	Tests		
<b>PAS4/68.5E</b>	4015/1135L	Mongolia	(Secam)	
	3743/1407V	RTPi		
<b>PAS7/68.5E</b>	3840/1310V	Home Ch.	(may be off)	
	3864/1286V	BBC World		
	3910/1240H	Sony TV	Hindi	
	3907/1243V	Maharishi		
	4034/1116V	Doordan		
	4085/1065H	CNNI		
	4110/1040H	TNT/Cartoon		
	4113/1037V	Series Ch.		
	4185/965H	MTV		
	3470/1680V	Test Signal		
<b>Ap2R/76E</b>	3740/1410H	Vasta Music	P5 NSW	
	3760/1390H	AXN card		
<b>Thaic3/78E</b>	4155/995V	DD12 Pal	Asian beam?	
	3871/1279H	TVT		
	3760/1390V	Army TV		
	3690/1460V	MRTV		
	3685/1465H	Mynamar		
	3635/1515V	RAJ-TV	also 3465V	
	3616/1534V	ATN		
	3576/1574V	ATN Bangla	Bengali	
	3554/1596V	RAJ Plus		
	3536/1614V	Punjabi TV	Punjabi	
	<b>Exp. 6/80E</b>	3672/1478L	TK Rossija	(north only)
		3875/1275L	VTV4+	(north only)
		3925/1225L	ACT/TB3	(north only)
4125/1025L		Russia 3	(north only)	
4025/1125L		Prometei AST	(north only)	
<b>ChiStr1/87.5</b>	3875/1275H	occ. feeds	P4 NSW Ntsc	
<b>CIS S6/90E</b>	3675/1475R	RTR I	P3 NSW	
	3875/1275R	Orbita I		
	3916/1234R	RTR II		
	3935/1215R	Orbita II		

<b>MeSat-1/91.5E</b>	3710/1440H	VTV 1,2, 4	
	3880/1270H	RTM-1	
<b>Insat2B/93.5E</b>	4163/987H	India Metro	Aust on 3.7m
	4128/1022V	Ind. National	Aust on 3.7m
	4070/1080H	India DD9	
	4080/1070V	DD7 (Tamil)	
	3970/1180V	DD9 (kan.)	
	3882/1268V	India DD1	
	3840/1310V	India DD	
<b>CIS-S20/96.5E</b>	3762/1388V	India DD4	
	3675/1475R	ORT	(this satellite
	3825/1325R	Madagascar +	may be out
<b>AsSat2/100.5E</b>	3875/1275R	Test Card	of service)
	3642/1508H	ERTU Egypt	
<b>CIS S21/103E</b>	3660/1490V	Test Card	
	3680/1470H	Feeds/Iran	
	3860/1290V	Feeds #	
	3885/1265H	WorldNet	VOA Subcar.
	3960/1190H	CCTV4	
	3980/1170V	RTPi	Radio Subcar.
	3675/1475R	RTR	
	3875/1275R	Vrk.Apt	
	4000/1150H	TVRI	
	<b>PalB2R/108E</b>	4183/967V	TPI/TVRI
4160/990H		(France) TV5	
4140/1010V		Brunei, feeds	
4120/1030H		MTV Asia	
4080/1070H		Herbalife	2100HK/NTSC
4040/1110H		CNBC	
4020/1130V		ANteve	(left air?)
3970/1180V		CNNI	(was 3980)
3900/1250V		Malaysia TV3	CA and FTA
3880/1270H		Aust. ATN7	
3840/1310H		TVRI	temporary?
3765/1385H		NBC, CNBC	Feeds, Herbalif
3742/1408V		RCTI	English subcar
<b>AsSat-G/122E</b>	3675/1475L	Moscow 6	Very powerful
<b>ChinSat 6/125</b>	4085/1065V	feeds	is it really here?
<b>G'zont29/130E</b>	3675/1475	test sig	+3775.3875
<b>Ap1A/134E</b>	3820/1330H	CETV SD	

## April Alert

With AsiaSat 3S testing at 98.2E, pay particular attention to frequencies between 4060/1090 and 4180/970 Vt and Hz where fewer conflicts with As2 exist. Target date to activate As3S from permanent 105.5E is early May. Orion 3 if launches April 22 could be testing by May 05-10 from 139E. As1 will go to 122E, As-G will be free to move elsewhere.

## UPCOMING SATELLITE LAUNCHES

Orion 3 to 139E - Resked 0100UTC. April 22  
 NSS-K to 95E - HP Ku, 30 Ku, April 28  
 Chinasat 8 to 115.5E-"May", 16Ku, 32 C  
 Telkom 1 to 108E - June (12-20) replace B2R  
 Asiastar (1452-1492 L-band) to 105E- June  
 KoreaSat 3 to 116E- August, 16Ku, replace Ks1  
 LMI 1 to 75E - Sept-Nov. HP Ku  
 Express A3 to 80E - September, C + Ku  
 GE1A to 97E - October (HP Ku)



53.2	55	57	66	68.8	76	78.5	80	87.5	88	93.5	93.5	98.2	100.4	103	105.5	107.1	108	110.5	113	120	
S27	2DT	I703	I704	PAS4 PAS7	Ap2	Th3	Ex2	Cs1	St1	Me-1	In2B	As3 temp	As2	S21	As1 (As3)	Ct1	B2R	Ss1	C2	Th1/ 2	
C	C	C	C	C	C	C	C	C	C,Ku	C	C,Ku	C	C,Ku	C,Ku	C	C	"S"	C	C,Ku	C,Ku	C

122	128	134	138	(139)	140	145	146	148	151	152	156	160	161?	166.5	169	174	177	180	177	148
As-G	Jc3	Ap1a	Ap1	Or3	S7	S16	Ag2	Me2	C1	A3	B3	B1	Mb1	PAS8	PAS2	I801	I702	I701	IF3	Es4
C	C,Ku	C	C	C,Ku	C	C	C,Ku	C,Ku	C	Ku	Ku	Ku	C	C,Ku	C,Ku	C	C,Ku	C	C,Ku	Ku

Ap1A/134E	3900/1250V	CETV2	
	3980/1170V	CETV1	
Ap1/138E	4160/990H	CCTV7	
S7/140E	3675/1475R	Test Card	mod. inclined
S16/145E	3675/1475R	ORT	high inclined
	3875/1275R	Feeds, tests	high inclined
Ag2/146E	3787/1363H	GMA	poor s. eqtor
Me2/148E	4080/1070H	test card	occ. use
C1/150E	4160/990H	TPI	occ. use
PAS8/166.5	3784/1366H	CNNI	only to 22/4?
PAS2/169E	3940/1240V	CNNI	1/2 Tr format
I802/174E	4166/984R	Feeds	
	4177/973R	Feeds	
I702/177E	4166/984R	Feeds	KBS Korea
	4187/963R	Feeds	Feeds
I701/180E	3810/1340R	Feeds	
	3841/1309L	RFO	East beam
	3845/1305R	Feeds	inc. USA
	3930/1220R	USA Feeds	Typ. encrypt.
	3975/1175R	Feeds	
	4060/1090L	Feeds	
	4130/1020L	Feeds	

### Major Changes - Next 30 Days

CNN launches digital PAS-8, planning 31-5-99 shut down of analogue (see. p. 2); TNT plans shut down PAS-2 31-5-99 (see p. 2). CMT testing CA, plans 01-07-99 FTA to CA change.

### Optus B3 at 156E / Ku only

12.720/1420V	Aurora MPEG	Irdeto CA IRD	see p. 15. 18
12.688/1388H	Austar MPEG	Irdeto CA IRD	list p.28, Feb
12.626/1326H	Austar MPEG	Irdeto CA IRD	list p.28, Feb
12.594/1296V	Aurora MPEG	Irdeto RABS	see p. 15.18
12.564/1263H	Austar MPEG	Irdeto CA IRD	list p. 28. Feb
12.532/1232V	Aurora MPEG	Irdeto RABS	see p. 15. 18
12.483/1183V	Herbalife	FTA analogue	NZ beam
12.438/1138H	Austar MPEG	Irdeto CA IRD	list p.28. Feb
12.407/1107V	Aurora MPEG	Irdeto RABS	see p. 15. 18

### Optus B1 at 160E / Ku only

12.730/1430H	RHEF, NZ feeds	typ FTA anal.	occ. use
12.677/1377H	QSTV	BMAC RABS	until 06/99?
12.670/1379V	SE ABC	BMAC RABS	until 06/99?
12.644/1344V	SE ABC	BMAC RABS	until 06/99?
12.639/1339H	NE SBS	BMAC RABS	until 06/99?
12.613/1313H	NE ABC	BMAC RABS	until 06/99?
12.576/1276H	ABC Radio	digital	
12.570/1270V	OmniCast		FM/FM
12.547/1247H	ABC feeds	typ. analogue	occ use
12.520/1220H	Net 9 feeds	typ. BMAC	
12.518/1218V	Sky NZ	NDS MPEG	& 12.546 (CA)
12.482/1182V	Net 10 feeds	typ. E-PAL	
12.480/1180H	Net 9 feeds	typ E-PAL	
12.455/1155V	Net 10 feeds	typ. analogue	
12.391/1091V	Sky NZ	NDS MPEG	& 12.418 (CA)

### Oddball Formats

PAS-4/68.8	3785/1365V	Discov. India	rptd BMAC
PAS-4/68.8	3860/1290H	ESPN Indian	rptd. BMAC
Ap2/76E	3960/1190H	HBO Asia	GI DigiCiph2
C2/113E	3930/1220H	Fil. Peo. Net	GI 1.5 MPEG
PAS2/169E	3836/1314H	ABS/CBN	GI 1.5 MPEG
PAS2/169E	3989/1161V	Fox/Prime	Sal.5MPEG

### AsiaSat 3S Transponders

1A-3660/1490Vt, 1B-3640/1510Hz, 2A-3700/1450Vt, 2B-3680/1470Hz, 3A-3740/1410Vt, 3B-3720/1430Hz, 4A-3780/1370Vt, 4B-3760/1390Hz, 5A-3820/1330Vt, 5B-3800/1350Hz, 6A-3860/1290Vt, 6B-3840/1310Hz, 7A-3900/1250Vt, 7B-3880/1270Hz, 8A-3940/1210Vt, 8B-3920/1230Hz, 9A-3980/1170Vt, 9B-3960/1190Hz, 10A-4020/1130Vt, 10B-4000/1150Hz, 11A-4060/1090Vt, 11B-4040/1110Hz, 12A-4100/1050Vt, 12B-4080/1070Hz, 13A-4140/1010Vt, 13B-4120/1130Hz, 14A-4180/970Vt, 14B-4160/990Hz

Note: Those underlined are active on AsiaSat 1 and should fire-up automatically on As3S when it turns on.

### Orion 3 Frequency Use

C-band service will be 10 transponders (5 each vertical and horizontal) in the expanded C-band region of 3.4 to 3.6 GHz. Ku-band service is split between two frequency bands - 11.450 - 11.700 and 12.250 - 12.750 with a total of 33 transponders.



# WITH THE OBSERVERS

Our deadline is simply too close to the start-up of serious testing from As3S to be able to give you very much concrete information. Here is what we Emailed to more than 900 readers on April 2:

- ✓ As3S is to be tested from a temporary location of 98.2E;
- ✓ When testing is completed (they believe by the last week in April), the bird will be moved to 105.5E "behind" As1 which it is replacing;
- ✓ On a date not yet firm, but 75% likely to be on or prior to May 8th, As1 will be turned off and As3S turned "on" in one simultaneous move.

Those who presently receive As1 will probably notice some variation in signal level on the As1 transponders we detailed on this page in March. Those living outside of the As1 footprint will suddenly see signals on the transponders we listed here in March. You can communicate with AsiaSat about the status of As3S through telephone ++852-2805-6677 (and 6678), fax ++852-2504-3871 or Email [scc@asiasat.com](mailto:scc@asiasat.com).

The As3S report card appearing on page 33 in this issue may NOT be able to be completed until after the deadline shown on the card - simply because As3S may not be operating from 105.5E until after the deadline. In that event, hold onto the card until you do have a chance to measure the new As3S service signals and then get the card away to us as rapidly as possible so SatFACTS can compile a full analysis of As3S coverage for our June issue.

We understand that some of the existing Star TV analogue programming, currently carried on As1, will be shut down just days prior to the As3S swap-over. In other words, programming channels (such as) Star World (3960 Hz, analogue) are unlikely to be seen through As3S. Star TV (Asia) is reported to be readying a new digital package that could include 20+ programming channels initially, twice that number within six months. These will - of course - be CA so the benefit of this for most readers will be small. The exception to this statement will be the VIVA! and Star News India services available through subscription from Solution 42 Pty Ltd (see p. 2, here) in Australia.

There will be new services on As3S - perhaps not as many as we had hoped, however. Arirang TV will be a new Korean export TV service using digital format - it hopes to be testing in June, to launch full day service August 12. FTA or CA? Not announced. Details? Scott Lee at tel ++822-3475-5150, fax ++822-3475-5306 and Email [tosolee.www.arirang.co.kr](mailto:tosolee.www.arirang.co.kr).

## AT PRESS DEADLINE

AsiaSat 3S (98.2E test location) beacons can be seen on spectrum analyser at 4199.5 and 4200.5. Saudi Arabia Channel 1 is now on AsiaSat 2, 3811/1339Hz Msym 3.095, FEC 3/4. Peter Merrett (WA) reports four test signals on PAS-8 Ku - 12.290, 12.370, 12.630 and 12.690. 12.370 measures strongest, 5.4dB more than GWN Ku on PAS-2 using same 2.3m system.

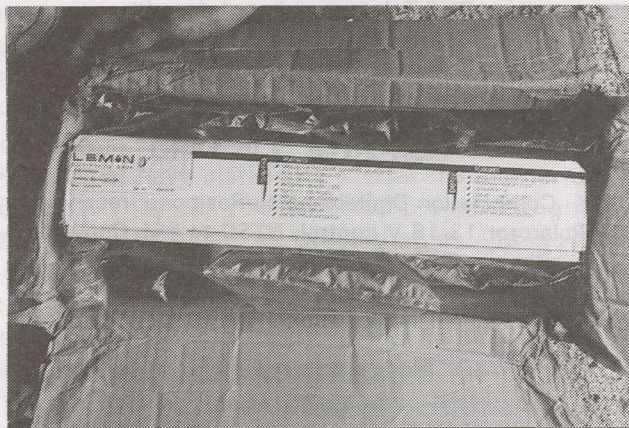

*Beats the hell out of egg cartons!* The Lemon Volksbox IRD from Germany is packed in "air." Leakproof bags blown up like balloons surround the IRD's cardboard box floating it inside of a parcel post shipping container. How well does it work? This one survived with "no leaks" coming half way around the world to SatFACTS. We'll have a technical report on the operation in a future issue.

Orion 3 launch, intended for April 6, was scrubbed because of wind, safety concerns. Rescheduled for April 7th, scrubbed again because of malfunctioning down range tracking radar. Third time could be the charm - as we go to press, 0100UTC April 22. Live launch coverage was on PAS-2 3966.5/1183.5 Hz, Msym 6.620, FEC 2/3. InSat 2E, heading for 83E, was successfully launched April 2; 17 C-band.

ApStar 2R/76E: Vasta Music testing 3740/1410Vt. Hallmark/Kermit FTA period stopped March 10, now (PowerVu) CA only on 3720/1430Hz. (Welsby, PNG)

AsiaSat 2/100.5E: WorldNet now digital parallel to analogue; 3764/1386Hz, Msym 6.100, FEC 3/4 - loads 20+ channels, same video, different audios for VOA feeds.

AsiaSat 3S/ temporarily 98.2E: Possible test carrier 3800/1350Hz. Try [www.realitygames.com/i76/tandy/](http://www.realitygames.com/i76/tandy/) and select As3S for earth view from satellite location. (Scarfe, SA)

Cakrawarta S-band/107.1E: 60+ programme channels now, identify, 38 load. (KP, Fiji)

Intelsat 701/180E: RFO came back up for a few days and then disappeared again. Does anyone know what happened to

**WITH THE OBSERVERS:** Reports of new programmers, changes in established programming sources are encouraged from readers throughout the Pacific and Asian regions. Information shared here is an important tool in our ever expanding satellite TV universe. Photos of yourself, your equipment or off-air photos taken from your TV screen are welcomed. TV screen photos: If PAL or SECAM, set camera to f3.5-f5 at 1/15th second with ASA 100 film; for NTSC, change shutter speed to 1/30th. Use no flash, set camera on tripod or hold steady. Alternately submit any VHS speed, format reception directly to SatFACTS and we will photograph for you. Deadline for May15th issue: May 4 by mail (use form appearing page 34), or 5PM NZT

May 5th if by fax to 64-9-406-1083 or Email

[Skyking@clear.net.nz](mailto:Skyking@clear.net.nz).



# SkyvisionAustralia

A Proudly Australian owned and operated company

## DSR-101 MPEG 2 DVB/Power Vu IRD

NTSC to PAL 50 Hz on board converter  
DVB Teletext on board decoder  
Automatic SR/FEC/POL/PID  
Low threshold Tuner, 5 language menu  
Firmware upgrade facility, Channel name edit mode

## DSR-201P 3 in 1 IRD

Combination Digital/Analog/Positioner receiver  
Polarotor/13/18 V control. NTSC to PAL Converter.  
Simple to install and use. Consumer Friendly.  
Reliable power supply module. Auto Sat Find.  
Low threshold Analog tuner. Heavy duty positioner.

## IRDETO CA IRD

Arriving in May!

Warehouse Direct prices!!

Full range of Satellite TV equipment in stock  
Call/Fax/Email for full spec's and prices

Tel: 02 62925850 Fax: 02 62925890  
Web Site: <http://www.bigfoot.com/~skyvision>  
E-mail: [skyvision@bigfoot.com](mailto:skyvision@bigfoot.com)

NBC feeds on 3966/1184? (Young, NSW) AFRTS Radio Pacific is on 4175/975L in PowerVu format.

Intelsat 703/57E: Sky News FTA 4143/1007R, Msym 5.632, FEC 3/4. (Sabaitini, WA)

Palapa C2/113E: Anteve is testing 4193/957Vt (Msym 6.508, FEC 3/4). TVRI analogue 3840/1310 Hz very strong. (Frost, Qld.) MCM Asia again gone from 3960/1190Hz. Taiwan bouquet 3760/1390 has added "Hot!" adult channel, was FTA one day, continues with audio in clear. (Senior, Vic.) Malaysia TV3 is primarily in clear, 3900/1220Vt. May not really be Indovision - 7 programme channels testing at 3580/1570Hz (Msym 26.850, FEC 7/8 in NDS CA) seem more likely to be Star TV Asia.

Optus B3/156E: SMS IRD used by Austar will do Aurora but has sync problems. At least two different versions, one does C-band including network and frequency search but with limited symbol range. (Moods) Herbalife has left 12.532Vt, now 12.483Vt. Austar/Foxtel planning to increase from 12 to 14 number of programme channels per pay-TV transponder: possibly as early as May 1. New UEC 642 IRDs now being routinely used by Foxtel as last of Pace DGT400s have been used. 642s have "Foxtel" name screen on Smartcard, warning not to mix Foxtel cards and DGT400 sets.

PAS2/169E: The 5 programme channel FTA middle east services on 3743/1407Hz (Msym 19.465, FEC 7/8) have gone down in level and programming replaced with test cards. (McLeod, NZ) Programme channel 5 was CNBC USA service. (Mathews, NZ) JET-TV (3962/1188Vt) will shut down in June, has already discontinued feeds on other birds. Adventist Global Communications now functioning to weekly



# MELBOURNE SATELLITES P/L

ACN 065 270 733  
Established 1992

Direct importers and suppliers of the following world renown products.

KTI  
ORBITRON  
PATRIOT  
JONSA  
ANDREW

ECHOSTAR  
SCIENTIFIC ATLANTA  
NOKIA  
IKUSI  
DX

GARDINER  
CALIFORNIA AMPLIFIER  
MTI  
CHAPARRAL  
ADL

Full range of cables, splitters and connectors.

Phone, fax or write for our 1998 Product SATalogue.

Sales/Warehouse - 84 Bayfield Road, Bayswater Victoria  
Construction Services - 13 Elsum Avenue, Bayswater Victoria  
Postal Address - PO Box 901, Bayswater 3153 Victoria Australia

Phone: (03) 9738 0888  
Fax: (03) 9729 8276

User Friendly Site! [www.melbournesatellites.com.au](http://www.melbournesatellites.com.au) e-mail: [sales@melbournesatellites.com.au](mailto:sales@melbournesatellites.com.au)



### Satellite TV that is not - ahhh, from a satellite

SatFACTS for December 1997 reported on tests conducted by New Zealand Internet Service Provider (ISP) IHUG using a 12 GHz (satellite Ku band) transmitter operating with a few watts of transmitter power from a tall building in downtown Auckland. The concept is - satellite without a satellite. Standard DTH receivers, standard digital format, only the satellite transmitter is affixed to the top of a tall building. Why?

First, it is far less expensive than a real satellite. Second, all of the hardware is off-the-shelf. The transmitter, the receivers, the CA systems, the digital multiplexers. Third, it is faster - you can go from planning to operation in a few months time.

Reader **Gregory Hermosa** in a Middle Eastern country (we won't tell you exactly where - here) has another example of using satellite frequencies for "local" coverage. Gregory is from the Philippines, lives and works in the Middle East as do thousands of his fellow country men and women. Filipinos want two kinds of television - neither of which is abundantly available, cheaply, in the Middle East. Number one - home town TV. Number two - American TV, in English.

On an ex-terrestrial TV tower, somebody (he suspects Americans) have installed a 1 watt transmitter that broadcasts in analogue format on 3.415, 3.450 and 3.485 GHz. They carry AFN/AFRTS programming from "Newsports," "Spectrum Movies," and "AFN Variety." It is NTSC, FTA, and as Gregory notes - "*It is really great to have them because we can watch live NBA and most sporting events as well as events such as the Grammy Awards, Oscars and so on.*"

Gregory is 40 km from the 1 watt transmitter, does not have clean "line of sight." Those in closer to the transmitter get by with a C-band LNB pointed towards the transmitter (no feedhorn, no dish). Further out, he sees people sticking LNBs inside of metal pails (turning the pail into a form of dish), home-brew yagi type antennas, and very small satellite reflectors. He has discovered the transmitting antenna pattern is a half circle, and there are multi-hundreds of homes and flats equipped with the funny little often-home-built antennas receiving the service. Gregory should know - he reports about "*25 installations I have done myself, all for close friends of course!*"

Perhaps if you live within transmission range of an American Forces facility, you will also find such a service available.

schedule (differs week to week) 1900-2030UTC 3957/1193 Hz (Msym 7.000, FEC 3/4) with multiple audio channels. TCS Singapore (4183/967 Hz) testing 18 hour per day Chinese all-news service on terrestrial link, plans to bring it up on satellite package.

**PAS8/166E:** CNN analogue on and off, NHK digital same. Are these "adjustments" or is there a new worry here? (**Browning**, NZ) CNN moved 4 MHz to 3784/1366Hz, perhaps in prep for digital feed? (**Mathews**, NZ) Ku (Internet data) tests 12.606Hz have 18 dB C/N whereas GWN on PAS-2 10.5dB on same system (**Merrett**, WA). Analogue test card 12.446Hz weak but identified (**Roosjeb**, Indonesia) "Best" of PAS-8 stronger than best of PAS-2. (**Ruhe**, Solomon Islands)

**ST1/88E:** In addition to SINGNET-BKT analogue test card (1510Hz), there are up to 7 digital carriers here (**Ingegneri**, Qld - most likely GI Digicipher, Ed.)

**Thaicom 3/78.5E:** Two new Indian channels testing 3600/1550 Msym 26.662, FEC 3/4: 1) Gurjari and 2) Lashkara in Punjabi (**Ditcham**, WA). Greek Skai-TV also here (**Leach**, NSW). Skai also on SCPC, 3435/1715 (3.905, 3/4). RTV1/2

testing on 3600/1550 (see above item, same frequency) had 7 programme channels (Msym 26.662, FEC 3/4).

Errata: New Caledonia planning national service linking their version of RFO to all islands + Vanuatu; Intelsat and Orion both possible delivery vehicles. When? Before end of year.

### POSITION VACANT

-in rapidly expanding communications company in Papua New Guinea. Contract is based in Port Moresby and involves supervision and quality control of field staff installations of cable and MMDS cable services. Please email/fax/post/courier CV to:

#### **HiTRON Ltd.**

PO Box 209, Waigani, NCD, Papua New Guinea  
Corner of Morata and Gabaka St., Gordons,  
Port Moresby

Email: ames@hitron.com.pg

Fax: (675) 325 0349

## small, medium and LARGE C and Ku antennas in stock!

Transmit and receive antennas from 1.2m to 13m (Intelsat Standard B). Linear and circular feeds (AsiaSat, Palapa, JcSat, Rimsat, PanAmSat, Intelsat and more) for transmit and receive-only applications. Receive and transmit electronics including inclined orbit tracking equipment with motor drives for elevation and azimuth to 50 tons. Complete system design, fabrication, installation + proof of performance.

### **Pacific Antennas Limited**

Bryon G.G. Evans, PO Box 265, Whangaparaoa, NZ  
Tel/fax 64-9-424-0841 • Mobile 025-789-160

P  
A  
C  
I  
F  
I  
C

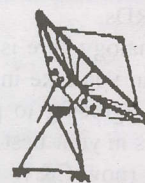

Limited

A  
N  
T  
E  
N  
N  
A  
S



# AT

## Sign-off

### Numbers

To appreciate why a major corporation such as C&W / Optus could get its financial department into such an incredible muddle that it elects to abandon DTH (satellite) TV, you have to return to basics. We sometimes tend to forget or overlook the fact that a corporation such as Optus is really no different than your household. Only they have more zeros in their chequebook balance line. And the invoices they must pay monthly have more zeros than the bills we typically receive as well.

Optus was at one point very optimistic about pay-TV. They jumped into the wiring of Australia, with a combination of coaxial cable and fibre optics, certain that by bundling (offering) a combination package of telephone calls and cable (pay) TV, they could capture a nice chunk of the market. They were not on unproved ground - in the UK, in those regions where cable offers telephony as a bonus to cable TV, established telephone company BT has lost 50-55% of their telephone subscribers. Telstra, Australia's established telephone company, had good reason to worry.

So certain was Optus that it would capture 25-50% of the local metropolitan markets with a combination service, it went out and signed agreements for television programming based upon "minimums." It agreed, for example, to pay Disney \$2,000,000 each month whether it had 1 subscriber or 1,000,000. With one million subscribers, Disney at \$2 per sub per month was manageable (but in the cable business, top dollar for programming). When Optus stagnated at 200,000 subscribers, it was effectively sending off \$10 per month *per subscriber* to Disney. Additionally, it had similar "minimum guarantee" numbers for the Hollywood studio products from Warner, MGM and Disney (films); \$10 per subscription home per month against (in this case) 750,000 "minimum" subscribers. So here we have Optus writing cheques of \$2,000,000 each month to Disney and \$7,500,000 per month to Hollywood to buy product to programme four of their channels (Movie 1, Movie Extra, Movie Greats and Disney). That's \$114,000,000 in 12 months or with 200,000 subscribers, \$570 per subscriber per year. Or to put it another way, \$47.50 per subscriber per month.

Suppose you agreed to purchase 1,000 receivers each year from a supplier at \$200 each but you sold only 200 at \$800 each? By your agreement, you would be writing cheques for \$200,000 but making deposits for only \$160,000. You'd be \$40,000 over drawn at the bank, and end the year with 800 unsold IRDs.

The analogy here is that you cannot last long if you spend more than you take in, and just because you can get a lower price by agreeing to purchase more of something does not mean it is in your best financial interests to do so.

Optus (now C&W Optus) possibly was the victim of bad timing. The proven attractiveness of offering cable TV and

telephony to residential customers is apparent from the UK experience. Even in business districts, UK cable-telephony has down remarkably well. But when Optus first turned on their coaxial cable + hybrid fibre optic plants, the only part that was functional was the TV. Consumers can live without cable TV, especially when it is brand new and they have never had it in their homes. They cannot get along very well without a telephone connection.

Optus wasted nearly three years able only to offer cable TV, at a time when Galaxy was the big time pay-TV name in Australia, at a time when people were picketing Optus work crews and engaging in civil disobedience in efforts to keep Optus from stringing new cables on existing pole lines.

Optus was unable to offer telephony at first because the technology was not ready for full scale field use. By the time it was properly functional (mid 1998), Foxtel had navigated itself into a position to take over the Galaxy satellite subscribers, and Foxtel cable TV had signed up twice as many pay-TV homes as Optus; *timing*.

Only now is Optus gaining ground with their twin offering. It has passed 100,000 local telephony subscribers, is now able to offer a bundled service that marries pay TV, long distance, local and mobile telephony and reports that 60% of the telephone customers "*also take pay-TV*." There is something curious about that number - in the UK where cable telephony is more established than any other spot on earth, they speak of 50-60-70 or 80% of their cable TV subscribers "*also taking telephony*." What this appears to be telling us is that as a telephone company, C&W Optus is starting to be a success; as a pay-TV company, they are still lagging far behind.

People in the UK take the combination package because cable telephony costs them (by curious coincidence) almost precisely what BT telephony alone costs. In other words, switch from BT to cable telephony and effectively get cable TV for free.

To convince the public to abandon their relationship with Telstra, C&W Optus must first be the technical equivalent of Telstra in telephony. Next, they have to offer the customer more service or cheaper service (or both). The UK combo firms have learned the least expensive "freebie" they can give away, to attract the customer's telephony business, is pay-TV. UK cable firms package their product such that when you buy cable TV alone, it is costly; when you buy telephony alone, it is equivalent to BT but also includes cable TV as a bonus.

Before Optus can *give away* cable TV as a bonus, it has to get out from under the "minimum guarantees" it has signed with the likes of Disney and Hollywood. They say this is finally about to happen, that they hope to shave \$70,000,000 per year from the foolishly optimistic guarantees they agreed to back when Optus entered the cable TV business.

What we all can learn from this exercise is to avoid bad planning with our own businesses. Optus will most probably survive this billion dollar mistake, but in the process it has been forced to sell off its fleet of satellites and raise money by courting a new majority owner in the form of Cable & Wireless. Moreover, by being cash starved and badly managed, it lost the window of opportunity to be a participant in the satellite TV delivery industry; *bad timing*.

In business, there is an opportune time and a bad time to initiate something brand new. "Opportune" is often very short, but bad lasts forever.



# THE 1999 SATELLITE EXPLOSION IN THE PACIFIC/ASIA!

**AsiaSat 3S is UP. Orion 3 - Telkom 1. The explosion continues!**

## **Stay tuned with SatFACTS!**

- ENTER my 12 MONTH subscription to SatFACTS starting with May 15th issue (rates below)  
 ENTER my 36 MONTH subscription to SatFACTS starting with May 15th issue (rates below)

NAME \_\_\_\_\_

Company (if applicable) \_\_\_\_\_

Mailing address \_\_\_\_\_

Town/city \_\_\_\_\_ Country \_\_\_\_\_

**Amount to send:** 1 year - NZ\$60 (inside New Zealand) / A\$90 (inside Australia) / US\$60 (outside of NZ and Australia) or 3 years - NZ\$140 / A\$210 / US\$150 if by cheque. **VISA** or **Mastercard**? See form below and return with order. Return to: **SatFACTS, PO Box 330, Mangonui, Far North, New Zealand** or if by VISA or Mastercard fax to 64-9-406-1083

**ALL SatFACTS SUBSCRIPTIONS ARE SENT VIA AIRMAIL - WORLD-WIDE!**

### USE THIS FORM ONLY WHEN CHARGING ON VISA/MASTERCARD

Please charge my **VISA/Mastercard** as follows:

- ONE Year of SatFACTS MONTHLY (NZ\$60, A\$90, US\$60)  
 THREE Years of SatFACTS MONTHLY (NZ\$140, A\$210, US\$150)  
 SATELLITE TELEVISION: The Booklet (NZ\$10, A\$12, US\$10)  
 One Year of COOP'S TECHNOLOGY DIGEST (NZ\$125, A\$125, US\$125)

Indicate charge card type:  VISA  Mastercard

Name (as it appears on **VISA / Mastercard**) \_\_\_\_\_

**VISA/Mastercard** Number \_\_\_\_\_ - \_\_\_\_\_ - \_\_\_\_\_ - \_\_\_\_\_

**VISA/Mastercard** expiration date \_\_\_\_\_

**Instructions:** If ordering by mail, return this complete (3-part) card or a copy of same (to **SatFACTS, PO Box 330, Mangonui, Far North, New Zealand**); if order by FAX, send full card as a single sheet to **64-9-406-1083**

### SUPPLEMENTAL MATERIALS from SatFACTS MONTHLY: Order Form

- SATELLITE TELEVISION:** The Booklet. Excellent introduction to home dish ownership for the layman, including major contributions from the father of geostationary satellites - famed science fiction writer *Arthur C. Clarke*. The perfect tool to help the satellite system seller explain home satellite TV to the layman consumer. From SPACE Pacific. NZ\$10/ A\$12 / US\$10, airmail.
- COOP'S TECHNOLOGY DIGEST.** For the really serious enthusiast, investor, business person in satellite television and allied leading edge technologies. Ten issues each year, jam-packed with information you will not find anyplace else. "Coop" routinely culls more than 60 publications world-wide, terribly expensive newsletters, Internet and his hundreds of private contacts to keep you right at the leading edge of technology on the **REAL** changes underway in telecommunications. Conveniently issued near the **first of the month**, creating an excellent time-line-filler between the mid-month issues of SatFACTS. Now in the **6th year**, airmail world-wide. Normally NZ/A/US\$250 per year - for SatFACTS subscribers special **50% discounted** price of NZ/A/US\$125.



## OBSERVER REPORTING FORM - Due May 3, 1999

- NEW programming sources seen since April 1st: \_\_\_\_\_
- Changes (signal level, transponder, programming content) in pre-existing programming sources since April 1st: \_\_\_\_\_
- OTHER (including changes in your receiving system): \_\_\_\_\_

NOTE: Please use P1 - P5 code when describing signal levels and receiver IF/RF settings.

Your Name \_\_\_\_\_  
Town/City \_\_\_\_\_  
Make/size dish \_\_\_\_\_ LNB \_\_\_\_\_ Receiver \_\_\_\_\_

Your email address \_\_\_\_\_ if you have one!

RETURN: SatFACTS, PO Box 330, Mangonui, Far North, NZ, fax 64-9-406-1083, Email Skyking@clear.net.nz

## LET US KNOW HOW YOU 'SEE' AsiaSat 3S!

Your name \_\_\_\_\_ Location \_\_\_\_\_  
Antenna size \_\_\_\_\_ LNB noise temp \_\_\_\_\_ Receiver(s) \_\_\_\_\_  
IF - if you could 'SEE' AsiaSat 1 at 105.5 E -  
AsiaSat 3S is \_\_\_\_\_ Lower in level \_\_\_\_\_ Same level \_\_\_\_\_ Stronger in level than As1.

**Use the 'P-code' to report your reception from each of the channels listed**

**P5** - Totally free of any noise, perfect; **P4** - Tearing on edges of vertical lines, sparklies (noise) hits on bright, saturated colours; **P3** - Moderate noise in picture, viewable without difficulty; **P2** - Very objectionable noise, can watch with difficulty; **P1** - I can tell it is there!

**Vertical:** 3940/1210-Zee India \_\_\_\_\_; 3980/1170-Zee TV \_\_\_\_\_; 4060/1090-Zee Cinema (Starcrypt) \_\_\_\_\_;  
4100/1050-PTV 2 \_\_\_\_\_.

**Horizontal:** 3800/1350-Star Sports \_\_\_\_\_; 3840/1310-Channel [V] \_\_\_\_\_; 3920/1230-Phoenix Chinese \_\_\_\_\_;  
3960/1190-Star World \_\_\_\_\_; 4120/1030-CCTV4 \_\_\_\_\_.

Comments: \_\_\_\_\_

## BECOME A MEMBER OF SPACE - protect your future!

- YES - Send SPACE membership data
- YES - Send SPACE/Mark Long Certification courses data

NAME \_\_\_\_\_

Company (if applicable) \_\_\_\_\_

Mailing address \_\_\_\_\_

Town/city \_\_\_\_\_



**SPACE Pacific Ltd.**

PO Box 30, Mangonui, Far North

New Zealand

Fax 64-9-406-1083



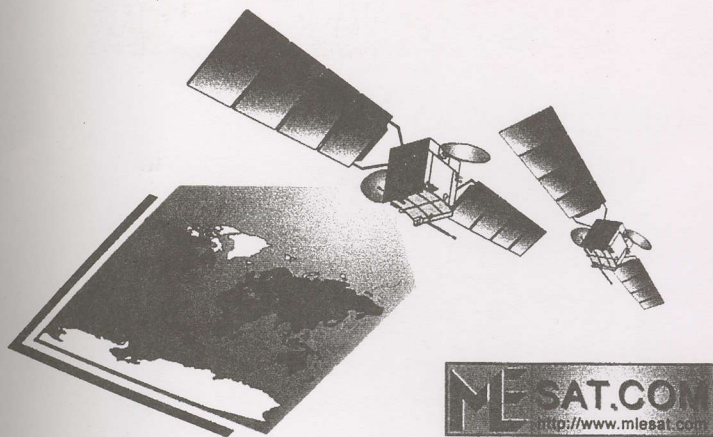

*Full colour footprint maps, frequency plans, spacecraft illustrations, transponder guides and contact information with supporting charts, graphs and photos for all the present and future telecom satellites.*

**MLESAT.COM CD ROM**

For Windows 95  
Windows NT 4.0

*Electronic Publishing for  
the Satellite Professional*

**SATELLITES  
ON DISK  
Library**

copyright 1998 Mark Long Enterprises, Inc.

It used to be that anyone needing access to technical information on telecommunication satellites had to wade through high-priced reference books containing hundreds of pages of text and technical drawings. Even then, the information in these vast tomes was out of date by the time the reader actually received it. The **SATELLITES ON DISK LIBRARY** allows you to access comprehensive, up-to-date technical information on geostationary communications satellites directly from your personal computer. What's more, you can quickly locate the graphic or text-based information you need, import it into your favourite word processing and page layout programs, and then add it to your own in-house reports, marketing studies, advertisements, customer proposals, and training materials. Best of all, you don't have to wait for anyone to print the next annual installment of their pre-historic paper publications because the **SATELLITES ON DISK LIBRARY** includes a software upgrade option which will allow you to download the latest updates from our Internet corporate site on the Worldwide Web.

*Covering Asia, Australia, Europe, The Middle East and the Pacific Rim  
All present and future satellites from 30 West to 183 East Longitude*

### The EURO-Asia/Pacific Edition SATELLITES ON DISK LIBRARY:

- 375 full-colour satellite footprint maps
- dozens of satellite line drawings
- 500+ pages of technical descriptions
- regional satellite summary charts
- transponder plans & activity charts
- other essential reference materials
- Runs on IBM PC compatible computers running Windows 95. Use Internet Explorer or Netscape Navigator to fully explore all HTML links.
- Easy to understand Installation manual.
- Optional Satellites-On-Line update service at <http://www.mlesat.com>

#### EURO-Asia/Pacific SATELLITES ON DISK LIBRARY

US\$ 129.95 plus \$15 shipping & handling. All checks must be in US dollars drawn on a US bank and made payable to MLE INC. Fax credit card orders or mail form together with payment to:

**MLE INC.** P. O. Box 159, Winter Beach, Florida 32971 USA  
Fax (1): 734-433-0935 E-mail: [mlesat@mlesat.com](mailto:mlesat@mlesat.com)

Name: \_\_\_\_\_

Company: \_\_\_\_\_

Address: \_\_\_\_\_

City: \_\_\_\_\_ State: \_\_\_\_\_

Zip: \_\_\_\_\_ Country: \_\_\_\_\_

Tel: \_\_\_\_\_ Fax: \_\_\_\_\_

MC/Visa: # \_\_\_\_\_

Exp. Date: \_\_\_\_\_ Signature: \_\_\_\_\_



# ANTEL

## Precision Spun Aluminium Dishes

### Antel 2.3

**Single piece spun aluminium dish.**

Total Diameter	2.4m
Reflector Diameter	2.3m
Pole size	102mm
F/D ratio:	0.4
Focal Distance	930mm
Gain: (>60% efficiency)	
4GHz	37.7dBi
12GHz	47.2dBi
Beamwidth 12GHz	0.53°
Maximum Wind Speed	
Operational	120kph
Survival	160kph
Finish:	
Dish	<b>Epoxy-Polyester Powder Coated</b>
Mount	<b>zinc plated</b>
Weight	
Polar mount	44kg
Reflector	33kg
Two mount options:	<b>Fixed &amp; Polar</b>

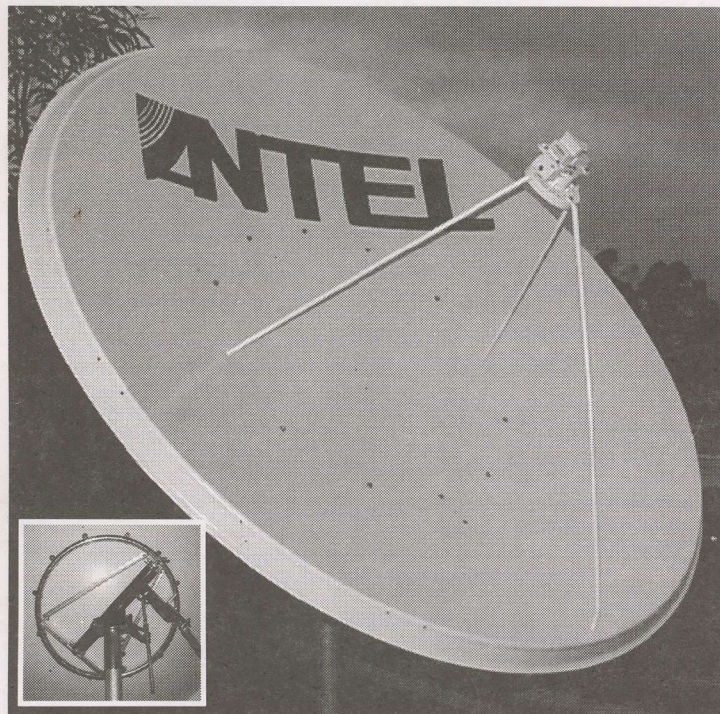

### Antel 1.8

**Single piece spun aluminium dish**

Total Diameter	1.9m
Reflector Diameter	1.8m
Pole size	89mm
F/D ratio:	0.41
Focal Distance	740mm
Gain: (>60% efficiency)	
12GHz	45.5dBi
Beamwidth 12GHz	1°
Maximum Wind Speed	
Operational	140kph

Finish:  
Dish **Epoxy-Polyester Powder Coated**

Two mount options: **Luxury Mount (fixed)**  
Spun aluminium ring,  
stainless steel elevation rod,  
fully galvanised pole cap.  
**Standard Mount (fixed)**  
Zinc plated ring, elevation rod  
and pole cap.

These quality products distributed by:

**SCITEQ**  
PTY LTD ACN 009 235 090

Phone: +61 8 9306 3738 Fax: +61 8 9306 3737  
sales@sciteq.com.au http://www.sciteq.com.au