

12-12-98 9AM

Bob Cooper's

DECEMBER 15 1998

SatFACTS

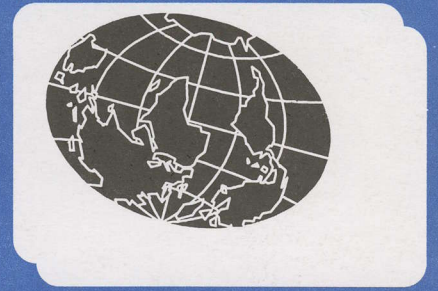

MONTHLY

Reporting on "The World" of satellite television in the Pacific and Asia

IN THIS ISSUE

**PAS-8
at your
service**

**Praxis 9800 AD
review, Our
Own TV "Show"**

**fTV Challenge,
180E Sources,
Combining Channels**

- ✓ Latest Programmer News
- ✓ Latest Hardware News
- ✓ Latest SPACE Pacific Reports
- ✓ Cable TV Connection

Vol. 5 ♦ No. 52

Price Per Copy:
NZ\$9/A\$10/US\$7

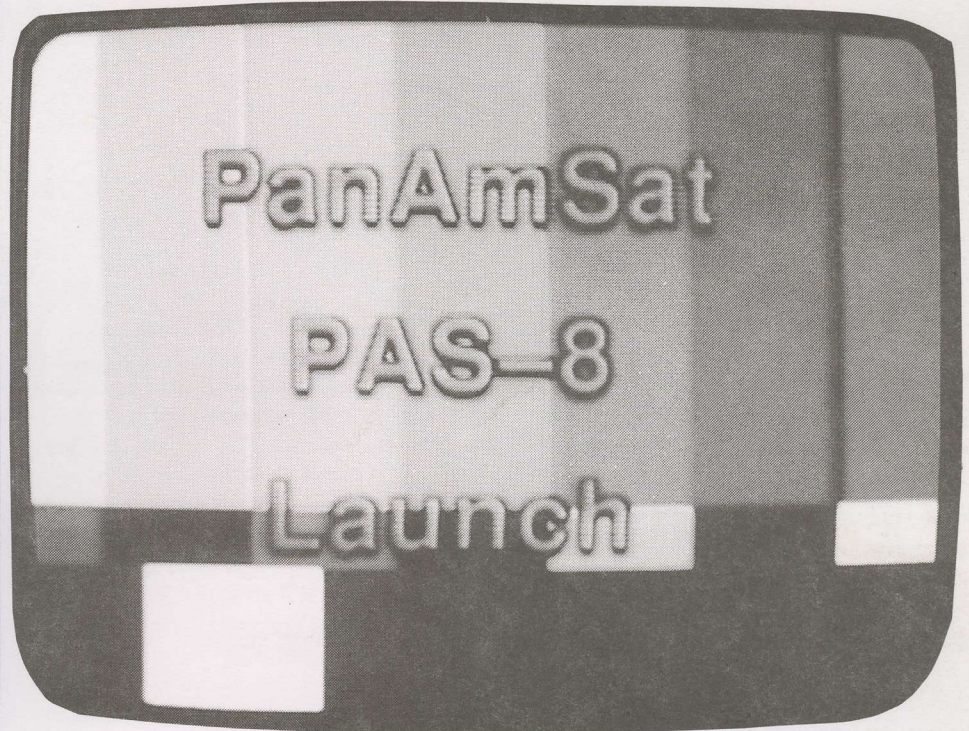

Paraclipse[®]

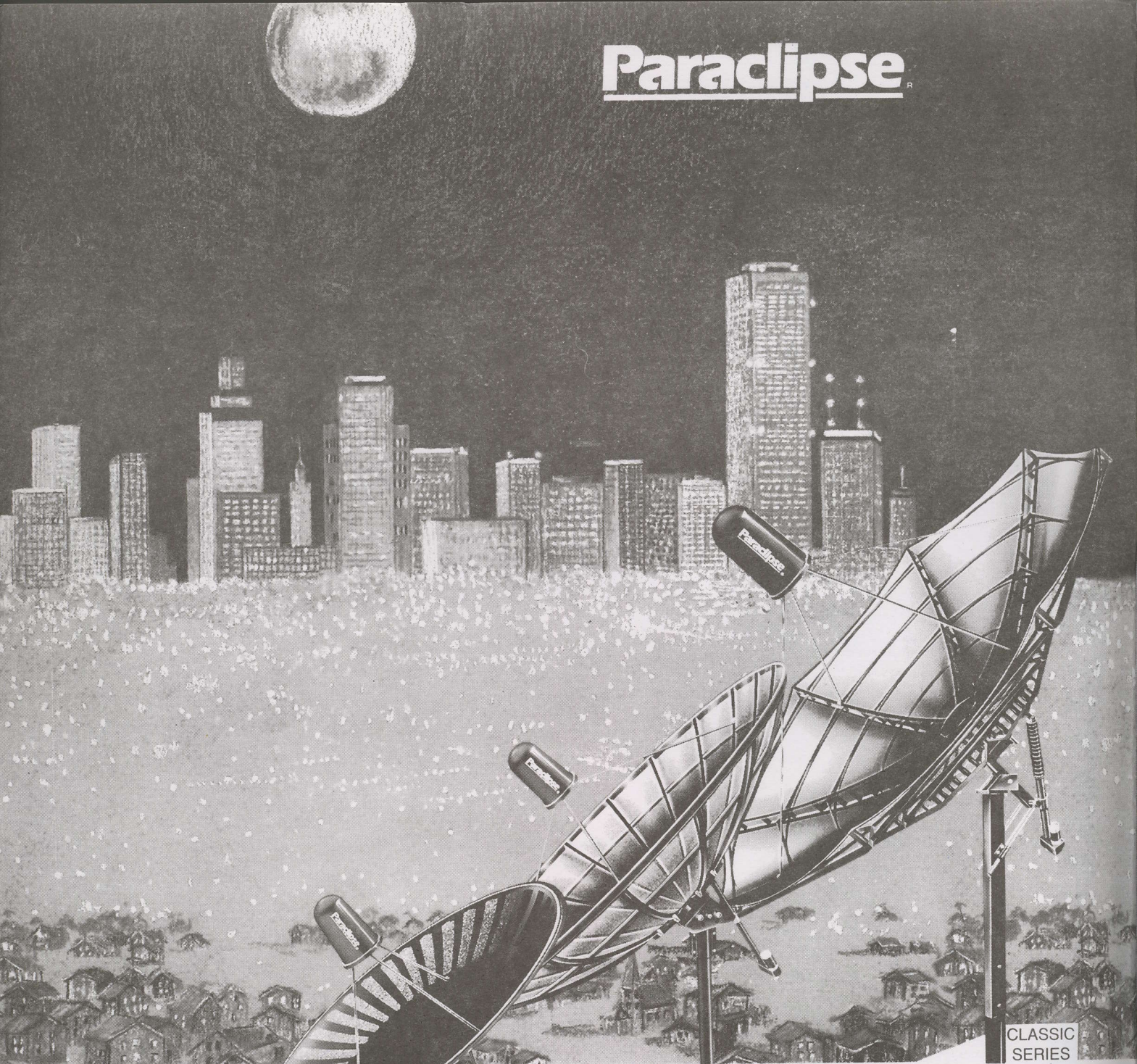

CLASSIC
SERIES

ECLIPSE
SERIES

HYDRO
SERIES

When quality, strength, and accuracy are your main requirements, **Paraclipse** antennas are your first choice.

Only **Paraclipse** offers such variety; four distinctly different series: the Truss-Ribbed Classic, the Courier Deliverable Eclipse, the Stretch Formed Hydro, the Commercial Patriot.

Every **Paraclipse** model sets the industry standard in its class, worldwide.

Distributed in Australia by

SKANDIA ELECTRONICS Pty Ltd.

183 Burwood Rd, Hawthorn, Melbourne
tel 61-3-9819-2466 • fax 61-3-9819-4281

Level 1, 39 Terry St, Rozelle, Sydney
tel 61-2-9555-2955 • fax 61-2-9555-2455

**SATECH Satellite Communication
Technology P.T.Y. L.T.D.**

6/477 Warrigal Rd, Moorabbin East, Vic.
tel 61-3-9553-3399 • fax 61-3-9553-3393

Distributed in New Zealand by

Bay Satellite TV Ltd.

PO Box 3311, Napier
tel 64-6-843-5296 • fax 64-6-843-6429

Paraclipse[®]

HIGH PERFORMANCE ANTENNAS

Paraclipse Inc.

2271 29th Avenue East, Columbus, Nebraska USA 68601
Telephone: (402) 563-3625 Fax: (402) 564-2109

★ MADE IN AMERICA

SatFACTS MONTHLY

ISSN 1174-0779

is published 12 times each year (on or about the 15th of each month) by Far North Cablevision, Ltd.

This publication is dedicated to the premise that as we enter the 21st century, ancient 20th century notions concerning borders and boundaries no longer define a person's horizon. In the air, all around you, are microwave signals carrying messages of entertainment, information and education.

These messages are available to anyone willing to install the appropriate receiving equipment and, where applicable, pay a monthly or annual fee to receive the content of these messages in the privacy of their own home. Welcome to the 21st century - a world without borders, a world without boundaries.

Editor/Publisher
Robert B. Cooper (ZL4AAA)
Office Manager
Gay V. Cooper (ZL1GG)

Reaching SatFACTS

Tel: 64-9-406-0651
Fax: 64-9-406-1083
Mail: PO Box 330
Mangonui, Far North
New Zealand

Subscription Rates

Within NZ: \$60 p/y
Australia: AV-COMM Pty Ltd, PO Box
225, Balgowlah, NSW 2093
61-2-9949-7417
Elsewhere: US\$60 p/y
All copies sent via airmail fast post
world-wide

ERRATA

SatFACTS Copyright 1998 by Robert
B. Cooper; any form of copying is a
violation of our international
copyrights. Advertising rate sheet
available upon request.

COOP'S COMMENT

If a lack of technical problems marks the success of a new product, the Pace Micro Technology DSR-600 series IRD for Sky NZ should be given the highest of accolades. A shipment of 2,000 IRDs left manufacturer Dovatron de Mexico on November 25th and were largely distributed and installed throughout New Zealand by December 4th. Sky claims "zero defects" with the initial shipment. As I unpacked the first of the four provided to Far North Cable TV as an



December 15, 1998

Standby indicator
Lights up red when the decoder is in standby (see page 4).

Urgent-messages indicator
Lights up when an urgent message has been received (see page 9).

Power-on indicator
Lights up green when the decoder is in use. Also: pulses when you press keys on your remote control.

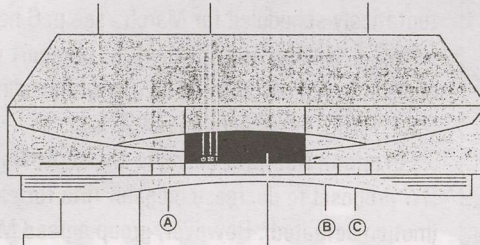

SKY card slot
Insert your SKY card, with the arrow facing up (i.e. gold chip facing down), into the slot behind the lift-up cover.



Standby button
Switches the decoder into and out of standby (see page 4).

Infra-red window
The remote control operates by sending an infra-red beam which is received at this window. Do not block the path between the remote control and this window.

affiliate of Sky, I was struck with the utter simplicity of the box itself. Perhaps that is how it should be for consumers who want the "decoder" to blend in harmlessly with the surroundings and never require any attention at all.

There is no LCD display, no green or yellow "numbers" staring back at you. In fact, the one tiny pinpoint of light (a green LED) quickly dissolves into the background after a few minutes. This is an IRD that "talks" to you only via the TV screen. The smart card "disappears" behind a left hand front panel door and is out of view.

There are two manuals available - one for the installer (pin number is 0000 as factory default) and

another for the consumer user. The installer version has been modified by highlighting the key steps required for a Sky NZ dish install - but is confusing to the extent that it includes a great deal of superfluous material that applies to some other country and some other pay-TV operation. The consumer manual, on the other hand, has been carefully and skilfully written for only NZ use; even the pseudo-off-screen illustrations feature Rugby action. If there is a "fault" with the consumer manual, it would be that the "real" off-screen photos taken of the various EPG related menus are very dark, difficult to read and the on-screen text they are trying to use as an example of what you will see when using the system is simply not legible. I could have given some advice on this since we have been publishing photos from TV screens since 1956!

Those who have been eagerly anticipating the DSR620 IRD in the belief it might allow them to venture off into other directions (such as non-Sky NZ services) will be disappointed. This device has been designed and built to support only a particular pay-TV format to the exclusion of all others. But for the purpose for which it is intended, I believe New Zealand is in for a fine ride on a well thought out electronic carpet.

Those are my first impressions. Next month, I'll have had weeks (instead of hours) to carefully wring out the performance virtues and we'll have a full report. Until then, our congratulations to all concerned at News Corp, Sky NZ and yes - even Pace.

In Volume 5 ♦ Number 52

Using Satellite to Communicate Within Our Industry -p. 6

FASHION TV - The "Ultimate Challenge" -p. 8

Review of PRAXIS 9800 AD -p. 11

Still Plenty of Action on 180E -p. 18

Departments

Programmer/Programming Update -p.2; Hardware/Equipment Update -p. 4;

SPACE Notes (First home receiver) -p. 20; Cable Connection

(Combining channels together) - p. 22; SatFACTS Digital Watch -p. 24; Supplemental Digital Data

-p. 26; SatFACTS Analogue Watch -p. 27; With The Observers -p. 29; Australian Piracy Update -

p. 30; At Sign-Off (SPN at the cross-roads) -p. 32

-ON THE COVER-

They lied to us. And blame Intelsat failure to provide a Russian link of the Proton launch. Never mind it was not on TV as promised. The important thing is - it IS at 166E.

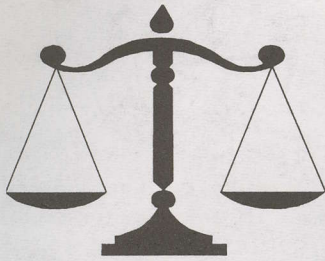

LETTERS

Scared SCART-Less

"I remain convinced there has to be a way to connect one LNB/dish to an analogue and separate digital receivers using the SCART connections on the back of both. Surely somebody knows how to do this?"

David Brown, Tasmania

We do not believe you can get there from SCART plugs which deal only in baseband products and switching signals. An Internet posting from Lars-Ingemar Lundstrom, identified as a Swedish satellite hardware expert, described a method to hook analogue to digital using SCART plugs. The concept was that at each geostationary satellite position on the belt, the analogue receiver would be tuned to the digital channel and the digital thruput would end up via a SCART cable into the digital IRD. Great concept, it does not work. To connect the L-band (satellite IF) signal coming from the LNB(F) to both receivers, either install a 'switch' that allows either receiver to connect to the L-band input, or, install an appropriate 2-way splitter to simultaneously feed both receivers. (If anyone has a SCART method proven to work, we would appreciate hearing about it!)

Duty is as duty does

"I was upset about errors in the SatFACTS digital and analogue watch tables until I realised that it is the duty of readers to inform you when receiving parameters change! So enclosed are 20 omissions or errors as I find them here in Thailand. Some other points - there are now additional receivers on the market that will do a full satellite search for any and all digital signals (reference the original Nokia V1.63). For example, a new Yuri model searches transponder by transponder but the downside is that it takes up to 10 hours to complete a search! In a recent load, it missed some including Fashion TV on As2 - perhaps because of the low Msym rate? And, your analogue watch omits most listings from AsiaSat 1 which happens to be the most watched satellite in Asia. Is this because it is not viewable 'down-under'? Finally, I am sure readers would appreciate having a separate listing only for FTA digital services? I'd give my eye-tooth to be able to subscribe to some of the Murdoch As2 services and it only angers me to see them listed but not touchable!"

Morris, Bangkok, Thailand

It is a reader's sworn duty when taking out a subscription to SatFACTS to feed back to us revisions and new service listings. The complex tables are the end result of hundreds - nay, thousands - of contributions. As1 - well, when it becomes As3 we'll carry it in detail. Murdoch/Star digital services? Something IS happening here and if As3 flies properly, you will be pleased. Good on Yuri's search ability but 10 hours to complete a search? Good grief!

PROGRAMMER PROGRAMMING PROMOTION

UPDATE

DECEMBER 15, 1998

SPACE Pacific Report (SPR) - the new weekly television programme to be distributed on AsiaSat 2 through the generous co-operation of Filipino broadcaster KIBC-TV, will have a "floating schedule" for air dates and time. You can find out when the programme is scheduled by checking popular industry web sites including <http://www.avcomm.com.au> and <http://www.sciteq.com.au>. First broadcast tentatively scheduled for March - see p. 6 here.

PAS-8 testing - one of the first to report was Robin Colquhoun (Auckland, NZ) midday November 24th. A full report including which services are scheduled to move from PAS-2 to '8' here on p. 29.

European bouquet changes ahead. At November meeting in Madrid, partners heard DW proposal to decrease megabit rate for each video service and add a 6th user (motion defeated). However, group agreed MCM could leave this bouquet as soon as a replacement partner is found to take over MCM contract obligations. Best bet at this time - TRT Turkey. Where would MCM go? See report on p. 8.

Other Euro-Bouquet participant changes coming. Spain's RTVE is starting a new '24 Horas' all news channel, it won't be on Euro bouquet but may eventually find its way into Asia/Pacific. A new turnaround facility is being built in Cyprus by British firm MERLIN with the co-operation of satellite operator AsiaSat and Cyprus Telecom. The station will link to AsiaSat (2 and 3) when finished and probable first customers include 24 Horas and Greek's ERT. Yes, that suggests both will be visible to our part of the world within first half of 1999. Present uplink site to AsiaSat is in Bezeq, Israel and problems there are legendary.

RAI Euro-Bouquet service has been suffering glitch and lockup problems since early October; not your fault. They blame uplink operators at Bezeq, who in turn blame November was a bad month for Bezeq - in addition to RAI problems, RTVE audio was 'out of phase' many times (result - low audio level through modulator) and some Hyundai owners report total loss of bouquet. Bezeq is bad news and TV5, for one, wants out of Israel (will go to Intelsat at 66E and then turn around to AsiaSat for bouquet).

CNBC Weekend Sports. We observed on this page in SF#50 a trend for more sport programming to appear on CNBC on weekends. Now it is "official." CNBC will average 12 hours of sport every weekend including PGA TOUR golf, tennis, sailing and skiing under a new corporate banner of CNBC Sports International Ltd. CNBC Asia claims reach of 12 million homes full-time, an additional 50 million part-time and carriage in 250,000 Asia + Pacific hotel rooms. Not bad.

Don't touch that dial. Yes, CMT does on occasion lockup (freeze frame). It is probably not your IRD. Check BBC, Bloomberg, EWTN to see if bouquet is still running. CMT lockup is at their uplink, related to special programme feeds now created for Australia and Pacific.

Subject to approval. New Western Australia satellite TV provider WIN-TV wants to serve both WA and SE (south-east) regions using Optus Aurora platform.

FoxStarPus? OpAuTel? FxAuOp? Latest pub game in Sydney - trying to merge the brand names Foxtel with Austar with Optus. Heavy rumours a deal has been - is about to be - signed putting Austar into rural regions east of Alice Springs, Optus into rural regions west of the line and Foxtel into the urban (city) regions across Australia. The concept is no real competition and a shared use of programming channels. Foxtel comes out the winner in terms of potential satellite homes, Optus gets to stay in business and Austar holds onto the rural regions. PAS-8 Ku? *Tune in next month!*



Communication
is the key *so tell your friends.*

SKANDIAS *CHRISTMAS SALE*
19th DECEMBER. BACK WAREHOUSE
LYNCH ST HAWTHORN.

SPECIALS ON OFFER
FROM 8.30am - 11.00am
CASH TALKS BULLSHIT WALKS

Get your accounts in order and dont miss out.

Fax 03 9819 4281 and register your interest to obtain full list of products on offer.

Phone: (03) 9819 2466
Fax: (03) 9819 4281



Don't try this at home

"(Reference letter appearing here in November issue) Solder (63:37) used by UEC and most manufacturers starts to melt at around 280C, a temperature few environmental chambers can reach. The soldering process requires the solder to reach at least 300C to achieve a proper solder joint. I really doubt your observation at 90C and would be interested to hear your test set up and methodology. The temperature test referred to in your letters section is a true story. The test done was to ensure a new plastic fascia on the UEC 642 case would survive high temperatures during storage without deforming. During this test we decided to hook up the IRD and monitor when it shut down (performing). We used an environmental chamber that is capable of a 4 degree C change per minute between -60 and +150 (C). We noted the IRD shut down at around 113C and the plastic began to deform at 128C. The chamber was then gradually cooled down and the temperature was allowed to stabilise. At around 100C the unit rebooted on its own, displaying a picture and normal operation."

Russell Futter, UEC

Lacking a carefully monitored environmental test chamber, we stuck a 642 into Mrs Cooper's oven and shoved a meat thermometer into one of those non-dangerous slot holes in the top. When we tried to leave it hooked up to observe the temperature at which it quit operating, the cables coming out the door allowed too much heat to escape so we gave that up and simply disconnected the unit and sealed the door. When the meat thermometer got to 90 degree there was a frying noise inside and when we opened the door and pulled the 642 out to inspect, the board was snapping and popping from the heat. We planned to stick it straight into the household freezer for a rapid cool down but couldn't find room because young Seth had filled it with ice blocks. (We are sorry - but the entire concept of an IRD functioning when the case temperature is the same as boiling water - 100C - leaves us 'cold'.)

Note: Russell is right about soldering melting at 280C. Most bench irons claim operating temperatures in the region between 340 and 400C. If the plastic fascia deforms at 128C, heaven help the transformer laminations and insulation materials at temperatures near 100C!

"The letter appearing on p. 2 of November regarding UEC 642. One does not have to be a rocket scientist to deduce the letter was written by somebody associated with UEC (the last 5 lines give that away). I would like to suggest that unless a person is willing to sign his name to a letter, you establish a 'no-publish-here' rule. People who hide behind fictitious names or being anonymous seldom have anything worthwhile to contribute anyhow."

Bob Kelleher, Antares Satellite, Strathpine, Qld.

In the interest of fairness to all concerned in the UEC IRD controversy, we elected to publish the letter. And it attracted feedback of its own (see top of this page; this one was signed). Now that we have published the letter, we invite the creator to be man (or woman) enough to write again and identify himself.

HARDWARE EQUIPMENT PARTS

UPDATE

DECEMBER 15, 1998

Technical challenge. Virtually every MPEG-2 IRD is equipped with the RS232 family of port. What many of us would love to have is a simple to implement software programme that will allow us to do the following through a typical home PC: (1) Select a specific IRD memory channel on a date and time switch basis, (2) operate if required a 12 volt relay to switch the receiver L-band input from one antenna (feed) to another (suggesting not every feed we want or need to monitor is always on the same polarity or even the same dish). The computer's clock would be the timer in this scenario, commanding the IRD to move around its own universe of in-memory channels and simultaneously selecting the appropriate L-band antenna feed for the receiver. And if the IRD happens to be equipped with twin L-band digital inputs, operate the polarity switch to select which antenna input goes to the receiver with each programme channel selected. Can you do it? Fame and ... well, fame - in SatFACTS to the first one with a working package we can test and validate here!

Leonids? Turned out not a threat - this year. But wait - only a small percentage of the astronomers who specialise in this obscure field predicted 1998 for the peak. The majority predicted it will be in 1999 (November 18th, +/- 01:48UTC). Why can't they be more precise? Finding the 'core' of the comet is difficult but possible - however, finding the debris laden tail and calculating when earth will cross through the stream is far more difficult. Ask ten astronomers and get ten different answers. 1998 was obviously not the answer which leaves us with 1999.

Satellite Internet? Eric Fien believes there will be as many as five competitive satellite to home/business competitors in Australia/NZ/South Pacific market before midyear 1999. Present NZ IHUG provider has been "beta testing" up to 200 *Australian* terminals from PAS-2 Ku feed (12.450Hz, Msym 20.557, FEC 3/4); indications are larger antennas than predicted (2.4m for 500 kilobit stream) are required. One installer problem - getting cross pole isolation spot-on since IHUG downlink on horizontal is frequency shared with Internet backbone feed out of USA on vertical. High error rates usually mean dish is too small, or, feed needs to be tweaked to get rid of opposite pole signal leaking through. Optus plan for Internet is to provide twin service feeds on B1 and B3, using vertical and horizontal, to entire country with "local call connection" to all locations for 'POP' (point of presence) dial-in connection. Optus target dates? "May or June."

Joys of being a supplier in this business. Quotes from people calling Garry Cratt at AV-COMM in Sydney during one week of November: "How big is a 2.3m dish?" "How can I get Sky Channel?" "How much is your \$995 system?" "I pointed my dish south and I'm sure I saw AsiaSat" (caller was in Australia). And the 'winner' for the month - this exchange: "Where do I point our dish for PAS-2?" (GC) "Where are you?" (caller) "I can't tell you that, it's a military secret." (GC) "OK, what is your lat and long?" (Caller) (gives co-ordinates for Singapore). (GC) "Oh, you're in Singapore." (Caller) "Shit! How did you know that?"

What's in a name? Plenty if you believe others might attempt to trade "disguised" under your trading name. UEC is case in point; as we all know, a South African firm that builds digital IRDs. It is also a Chinese firm (United China Electronics) based in Hong Kong (<http://www.asiansources.com/unitedch.co>) manufacturing consumer audio products, street traffic lamps and ... a single tuner analog + digital satellite receiver. Both UEC firms are now trading in Australia. Ooops.

Nokia 2000S release delayed to end of December by factory.

 Bridgeable Mosfet Power Amplifier
AUDIO SYSTEMS

MODEL:7504W

ADL[®]

BECAUSE PERFORMANCE IS ALWAYS YOUR FIRST PRIORITY

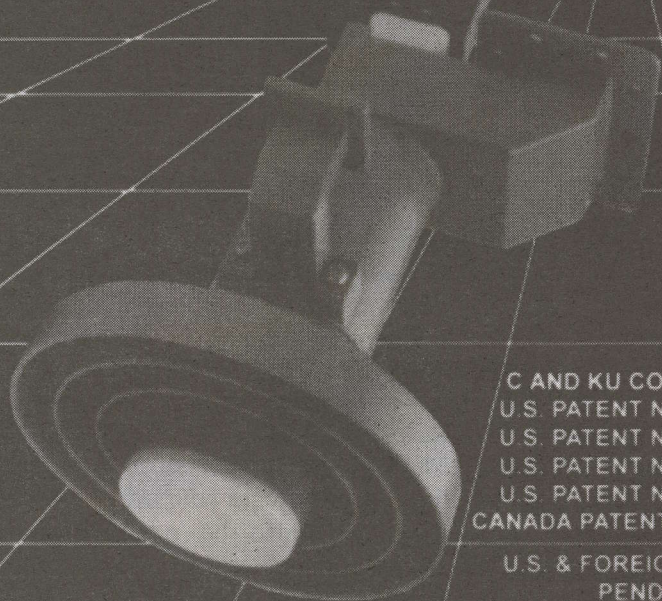

RP3-CKU/ International
Adjustable Scalar Ring Feed
with Extended C Band

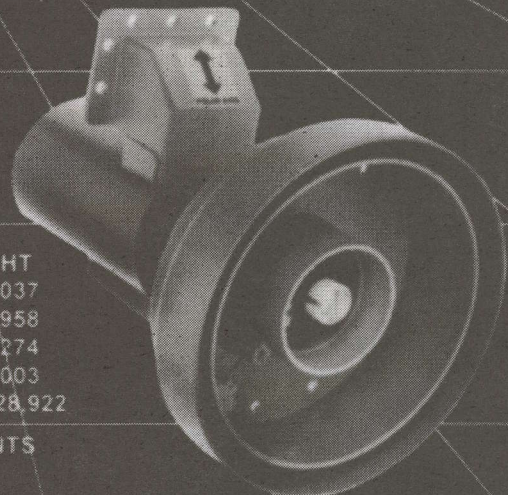

RPI-CKU Feed

C AND KU CO-BORSIGHT
U.S. PATENT NO. 4,903,037
U.S. PATENT NO. 5,066,958
U.S. PATENT NO. 5,107,274
U.S. PATENT NO. 5,255,003
CANADA PATENT NO. 1,328,922

U.S. & FOREIGN PATENTS
PENDING

ADL HYBRID MODING CIRCULAR POLARIZED INTELSAT FEEDS WITH EXCLUSIVE T.I. REJECTION



RP1-CP400



CP-300



CPOR-100

- C BAND LINEAR & CIRCULAR • C/KU LINEAR & CIRCULAR • KU 12 GHz FEEDS
- INTELSAT 4 GHz CIRCULAR • ARABSAT S BAND FEEDS
- OPTIONAL: CO-BORSIGHT S BAND

2216 AGATE COURT, UNIT B, SIMI VALLEY, CALIFORNIA 93065 • (805) 526-5249 • FAX (805) 584-0634

E-mail: ADL@thegrid.net • Web site: <http://www.thegrid.net/adl/>

Using Satellite to Communicate Within Our Industry

As reported in SatFACTS for November (p. 32), our industry (comprising TVRO, uplinkers, satellite operators and equipment suppliers) began communicating with itself through satellite relay of programming intended for dish people very early - 1978 to be precise. Weekly one hour (and longer) programmes, distributed initially throughout North America, brought to dish installers and users the latest in technology, satellite activity reports, and on-site visits with famous people such as Sir Arthur C. Clarke, the visionary who is generally credited with "designing" the geostationary satellite system.

The largest collection of videotape programming known in this field runs to more than 300 hours and by good fortune is now under the custodianship of trade association SPACE Pacific. Following protracted negotiations and more than a year of planning, dish industry personnel located within viewing range of AsiaSat 2 will have a new resource to supplement SatFACTS Monthly (and Coop's Technology Digest) as early as March. SPACE Pacific Report (SPR) will be a one hour per week (sometimes longer) television programme created to keep you current with the technology of today as well as providing a background of the technical and political events that are the foundation of today's satellite industry.

SPR is more than an Asia/Pacific effort. With the co-operation of Germany's *Tele-Satellit* (TS) trade magazine (perhaps the world's largest with a circulation world-wide of more than 80,000), TS Senior Editor Christian Mass has been producing a three hour monthly TV programme currently distributed throughout Europe via satellite. The "*Dr Dish*" programme like SPR has the support of equipment suppliers but unlike SPR it is multi-lingual because of the diverse audience base served.

Mass (alias Dr Dish) has already utilised material drawn from the SPR "library" in his monthly show and this is but the start of a co-operative agreement that will see Dr Dish and SPR routinely exchanging videotaped material for use in both programmes. Of even greater interest, the 1999 South Pacific Region Satellite & Cable Show (**SPRSCS '99**) scheduled for late March in New Zealand is being structured as a "*gigantic four-day TV shoot*" to create additional archival videotape material for use by both Dr Dish and SPR throughout the balance of 1999 and into 2000. Christian

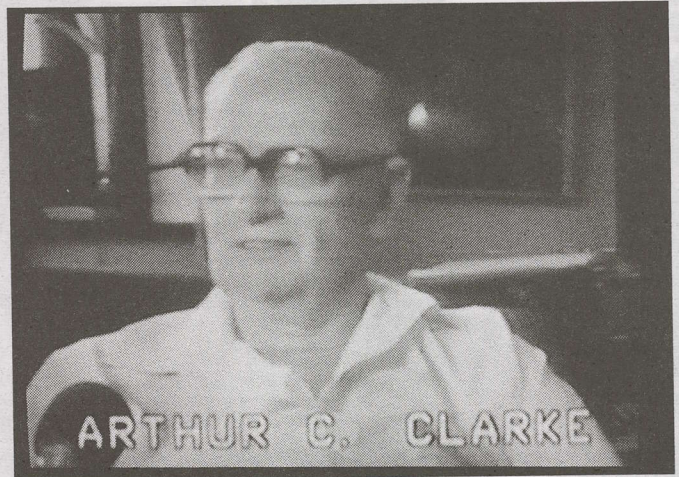

The *Godfather* of satellite communications - Sir Arthur C. Clarke videotaped during TVRO industry visit in 1983.

Mass is coming to New Zealand to participate in the four day event. Mark Long, creator of the SPACE Pacific twin satellite TV certificate courses offered by the trade association, will also be on hand as a contributor to the TV programme project.

SPR will be a combination of hands-on practical material, that viewers can put to use in their own system installations, and insider interviews. For example, Arthur C. Clarke was visited by a group of 25 satellite TV suppliers at his home in Sri Lanka in 1983; the group transported 3 sizeable dishes (from 4.5 to 7m in size) which were installed as gifts to Clarke and Colombo's University of Moratuwa. The Clarke visit, like virtually every other memorable event in TVRO from 1975 onward, was captured on videotape and will

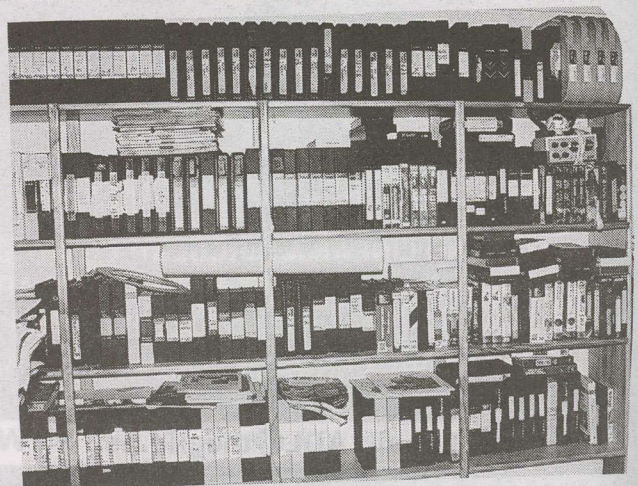

A portion of the "treasure" - more than 300 hours of videotape documenting 1975 to 1990.



Subic Bay uplinked KIBC-TV (AsiaSat 2, 3940Vt) is one host for SPACE Pacific Report; others are being negotiated.

be featured. The USA TVRO trade show sequence ran to three major events each year (1979-1986) and videotape of trade show sessions, important developments (such as the very first home satellite receiver developed) and personalities are in the "library." There are many light moments as well including some vintage Ted Turner (before his hair turned grey!) and the hilarious account of how an 11 metre "mothballed" uplink was dusted off and put into service for the industry's first "Live Trade Show via satellite(1978)."

Supporting the effort

Dr Dish and SPACE Pacific Report programming are non-commercial projects. But both have not insignificant assembly costs since the raw tape footage has to be combined into coherent (if not always totally CNN-quality!) presentations. Dr Dish has enjoyed commercial support from a number of European firms; SPR has indications of financial support from many of the major equipment suppliers you see advertising in this issue of SatFACTS. Alas, that will not be nearly enough to sustain the project even with the on-satellite

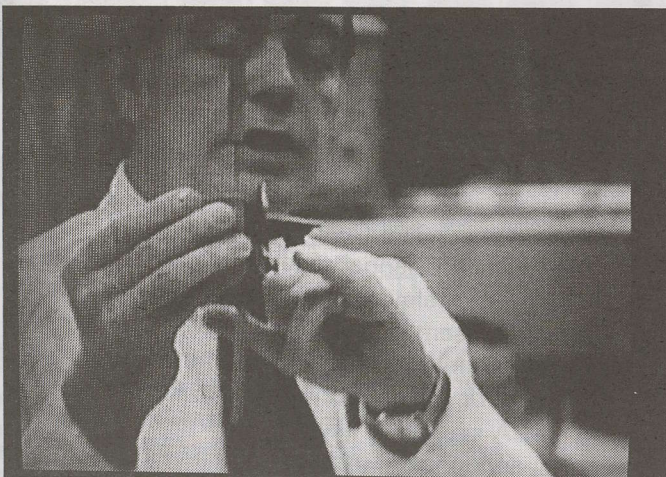

Tour of RCA uplink centre in Pennsylvania, director Archie Taylor explains how geostationary satellites are "flown" by ground controllers.

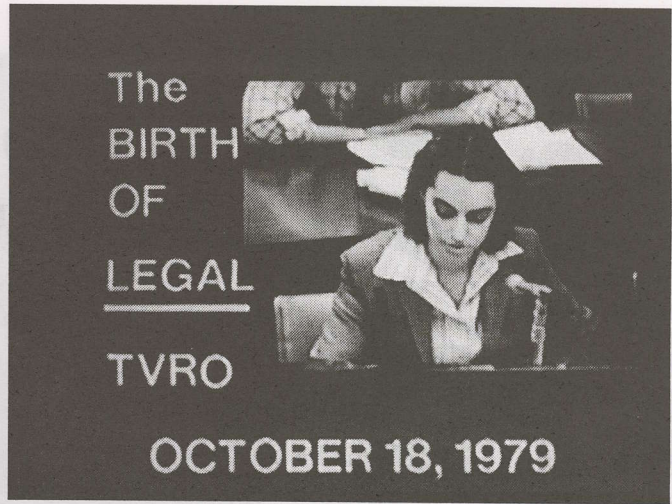

"TVRO's Fifth Birthday Party" reflected upon 60 months of industry growth following legalisation in 1979, a two-hour broadcast courtesy of HBO.

time being generously donated by KIBC-TV (and probably others before we commence operations).

SPR is to be the major effort of the trade association during 1999. Funding will come from membership dues, SPRSCS '99 attendance fees and donations from members. The current (December) SPACE Newsletter details the support required to make this project sustainable for all of 1999; if you have not joined SPACE, you are encouraged to complete the card appearing at the rear of this issue to request SPACE membership materials.

Pre-launch broadcast

The first telecast on KIBC-TV will be a two hour programme originally created in 1984 to honour the "Fifth Birthday of TVRO." It was in October 1979 that the US regulatory body, (the) Federal Communications Commission, changed the law to allow privately owned home satellite dishes. Five years later, with home satellite dishes selling at the rate of over 100,000 per month, a special "birthday" broadcast was produced and distributed on an HBO satellite channel. We'll share this event with you as SPR launches in 1999.



"Dr Dish" (Christian Mass) of Tele-Satellit

THE FASHION CHANNEL CHALLENGE ON AsiaSat 2

There is a new service on satellite which under normal circumstances would attract only passing interest. These are not normal circumstances. Fashion TV (FTV) is a Paris created service widely distributed throughout Europe, Africa and the Middle East. The content is - well, *different*. The quick one line description *might* say something like this:

"Continuous fashion show with the latest designer clothing for both male and female as created at the world's leading fashion design houses."

Sitting there glued to the TV screen watching very tall, very thin models parading in somebody's concept of fashionable clothing seems on the surface as if it might have limited appeal. Alas, there is more. What the programming lacks in plot it more than amply makes up in visual attraction. There are special lingerie shows (featuring both men and women), and somebody in Paris putting this channel together is obsessed with see-through clothing materials (including lingerie). In short, FTV is attracting an unusual number of male viewers who are more interested in what they can see *under* the thin clothing than in the clothing itself. Think of it as Playboy Magazine with motion.

Too harsh? Spend a few minutes reading the across the screen bottom (English language) "crawl" messages. Here headlines address specific viewers with sentences that read like this:

"Middle Eastern men - would you like to talk directly and privately with one of our friendly fair skinned models? Have your credit card handy and call"

If you don't have a telephone and credit card handy, FTV offers you "private videos" of models and their on-screen message claims "*our lingerie show is the best seller.*"

OK- so FTV has cleverly created a channel which appeals to wealthy men who have insatiable appetites for well, as best we can determine, nobody has yet to call it the "Bill Clinton Channel." It is like an interactive catalogue - the interaction being the ability to spend credit card francs to actually *talk* with a model. We have not tried that aspect of the service so cannot report to you on the content of such conversations.

So why should it appeal to you? Reading SatFACTS, it is unlikely you fall into the "wealthy Middle Eastern gentleman" category. There is more. Purely science of course. This channel started off as the difficult service

The Parameters

3796.2/1353.8 Vt, Msym 2.533, FEC 3/4 on AsiaSat 2. Signal was *initially* 3 dB weaker in level than adjacent Guandong GXTV (3806/1344 Vt - see spectrum analyser photo here).

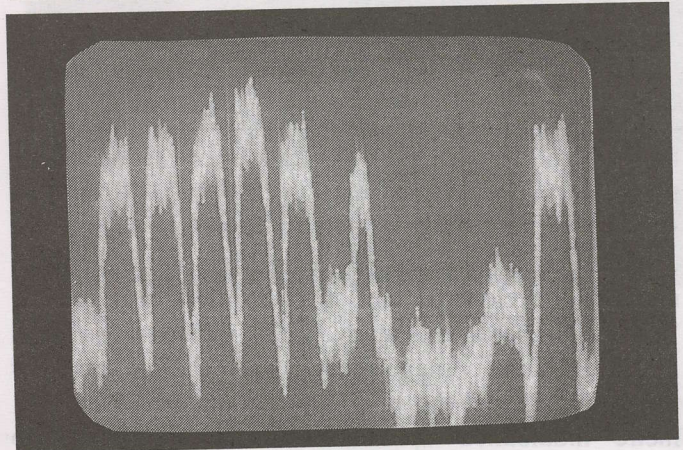

The Challenge - needle in the haystack. FTV is #6 from left edge, was 3 dB below GXTV (#5).

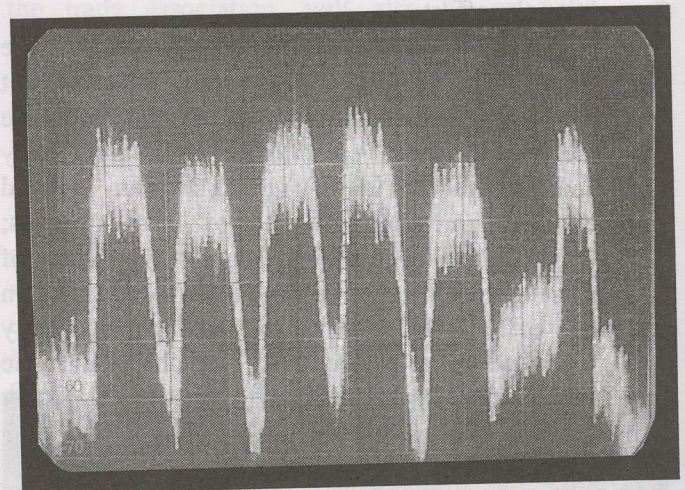

After November 18th, Bezeq got better control of uplink and level came up nearly 3 dB (fTV on right).

-The Changes Likely-

The Fashion Channel reportedly has a deal with MCM (music television) which will see Fashion + MCM's present channel + a new MCM jazz and classics channel form a 3-programme CA protected package for distribution on either AsiaSat 2 or 3.

The CA system is likely to be Viaccess but no formal announcement here. When? First MCM has to get clear of its contractual commitment with the European bouquet, then a new uplink package at Bezeq (Israel) and bingo - 3 new (CA) services!

The Most Advanced Free To Air Digital Satellite Receiver D7-MediaStar

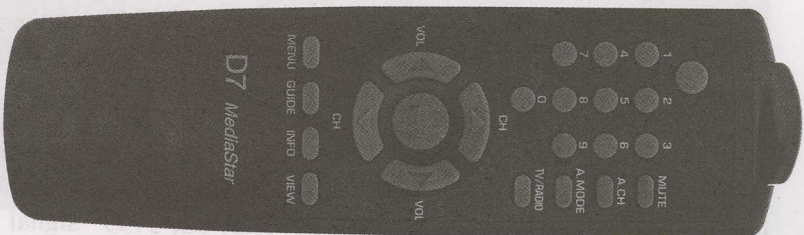
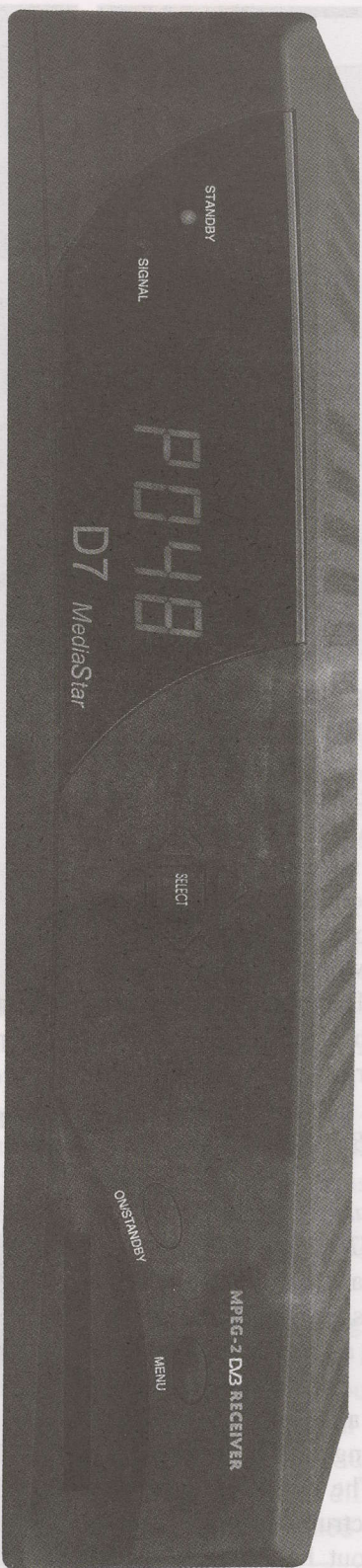

- MCPC/SCPC 2-36 Msym
- Direct channel selection from channel list
- Channel Edit menu Delete, Skip, ON.
- Fast response when changing channels
- No channel over-write
- 200 Video 100 Audio channels
- Automatic search and download
- 22 KHz switch
- PID Menu
- NTSC/PAL Auto switching NO NTSC Glitch
- NTSC converted to PAL-60Hz Free Option
- Audio L, R, Stereo selectable via remote control
- RF Modulator PAL-G, VCR/TV Scarts, RCA Audio/Video, SVHS outputs.
- 90-265VAC-50-60Hz power supply
- Low threshold performance



MediaStar Communications International
24 Bosci Road
Ingleburn NSW 2565 Australia

E-mail opac@bigpond.com
Tel + +61 2 9618 5777
Fax + +61 2 9618 5077

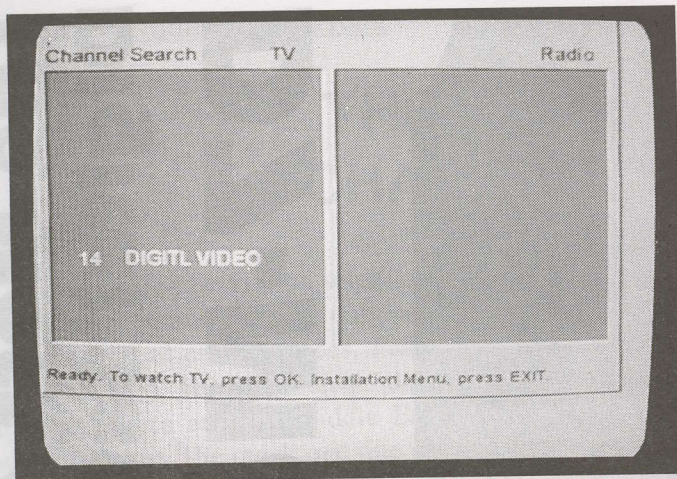

Loading usually says "Digtl" or "Digtl Video" - this from Nokia 2000S.

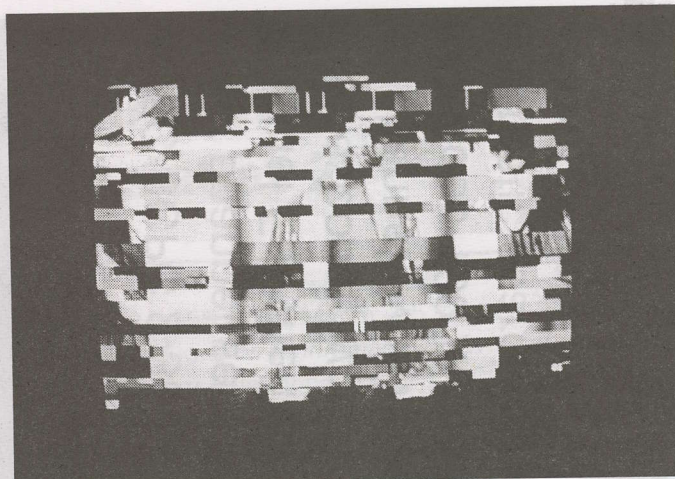

The Reality - it broke up, often. But it may not always be because of weak signal (see text).

to actually access with a terminal. If you wanted to test how good your system is, dial up FTV.

Why was that?

First there was the relatively weak signal level; 13 dB below a full transponder because, as AsiaSat Chief Engineer Barry Turner advises, "*They only occupy 10% of the transponder.*" How does that compute? If a full transponder is 39 dBw (a typical As2 number), half a transponder would have -3 dB of signal assigned to each half; 36 dBw. A quarter transponder would be 3 dB below a half transponder and now we are at -6 or 33 dBw. One eighth of a transponder would be down another 3 dB and now we are -9 or 31 dBw. One-tenth actually works out to being -10 dB which places us at 29 dBw. The -13? There is a back-off margin also applied to the transponder to ensure the signals don't "cross talk" with one another. That's *another 3 dB* which puts us at -13 dBw.

AsiaSat's Turner. "*We calculated the 3.7m dish size contour cuts through Japan for FTV.*" The As2 "normal" dish size for Japan is 1.8m for a 3 dB margin (excess signal above nominal digital threshold). A 3.7m antenna is at a minimum 7 dB better than a 1.8m. That translates to 4.3m in Sydney and 5.4m in Auckland. The photos you see here were taken on a 3.1m but we were *originally* at least 4 dB from having a 3 dB "margin."

There are other challenges. The symbol rate is very low (2.533) which as the spectrum analyser photos indicate is a narrow signal; about half the "spectrum width" of the Chinese SCPC signals we previously considered "narrow." This is double trouble.

First, the low Msym pushes the MPEG-2 processor in the IRD to its limits to stay "locked." More important, even a very small deviation in the LNB's local oscillator frequency pushes or pulls the very narrow signal right out of the capture range of the IRD's AFC (automatic frequency circuit). SatFACTS found our actual indicated receive frequency was not 3796(.2) but 3799 on a Nokia 2000S. One MHz in either direction and the

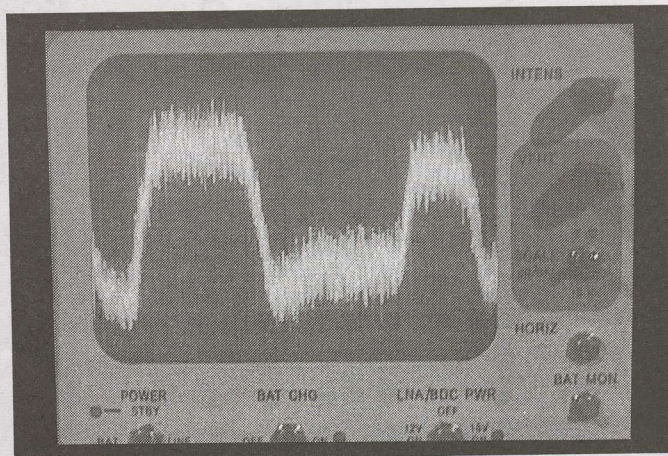

The Bandwidth Problem - yes, GXTV is Msym narrow (4.418 - left) but FTV is really narrow (right)



The Compression Trail - FTV uses many digital video processing tricks (doubtless a new "art form") which hides the fact that video quality is very poor.

lock was gone. So FTV is an excellent test for LNB noise figure (ultimate sensitivity), LNB stability as well as IRD capture range under very narrow band, low input signal level conditions. However - the fTV world got heaps (nearly 3 dB) better around November 18th when the Bezeq (Israel) uplink fixed some problems. It is now less of a challenge to access but no less intriguing.

No - This is not last month's report-

The PRAXIS DIGITAL + ANALOGUE 9800AD FTA RECEIVER

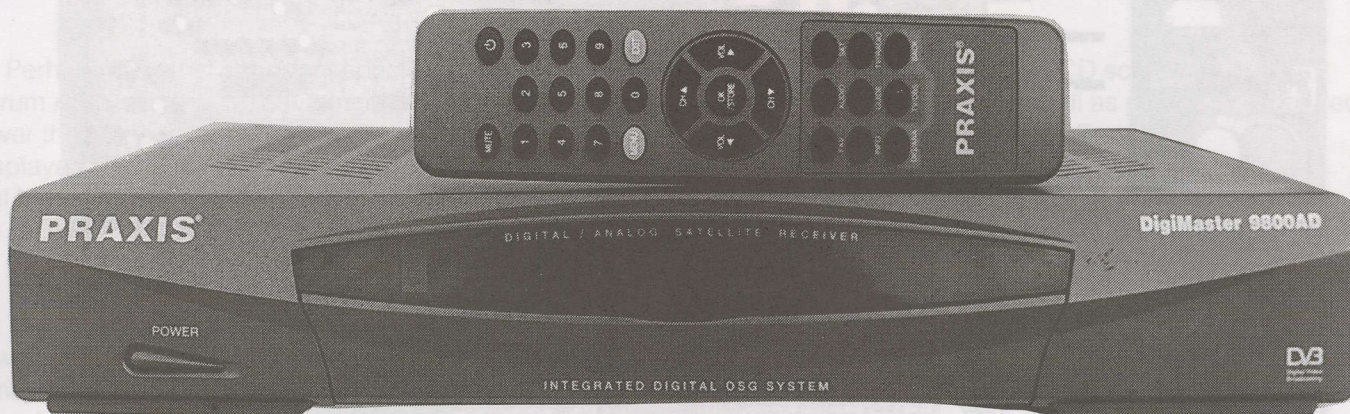

If you think this all looks very familiar, you are correct. The Praxis 9800 AD Digital / Analog Satellite Receiver is virtually identical in shape, size and component count to the Phoenix 333 Digital + Analogue + Controller IRD reviewed here last month. But there are some software differences.

Praxis is a brand name, like Phoenix (or, Pheonix as the case may be). Praxis is a world-size distributor of satellite hardware and they command sizeable attention from the original equipment manufacturers. But not the complete loyalty of the manufacturers. Think of it this way - you own a factory that produces widgets. You have a manufacturing capacity of 10,000 widgets per month and your largest customer takes 5,000 of these. To keep your plant humming, you agree to "label" 5,000 widgets with the name of your largest customer. For the balance of the 10,000 you are capable of producing you search for more customers. One takes 1,000, another takes 500 and so on until you have sold your manufacturing capacity. Each of your customers wants special concessions - they want the best price, and they want to create the "illusion" that their widget with their name on it is unique. Totally unlike other widgets carrying other brand names. So you oblige each of your widget customers, place their custom name on the

widgets you ship to them, and then it is up to the marketplace to sort out which is the "real" widget and which is a smaller production run "similar widget."

Only there is no "real" widget to the exclusion of all others because all 10,000 widgets, without respect to what name ends up on them as they leave your factory, are manufactured at the same time, using the same production line, the same testers, the same box packers.

A satellite receiver widget can be customised to the extent that the front name plate, the operating manual, and the labelling on the rear panel carry the name of your customer. And there is one more bit of customisation possible - the operating software inside of the satellite receiver widget can be modified to show the name of the customer as well. In this case, when you fire up the 9800 AD unit, it can say "Praxis" or "Pheonix 333" or "Sam's Bar and Grill" - as your customer dictates.

So the Praxis AD Digital / Analog Satellite Receiver is a Pheonix 333 is an Echostar AD2000 IP (bet you hadn't heard that one - unless you subscribe to CTD) is a ... whomever stands in line next to be a customer for the Korean factory that turns out these "widgets." Alas, there are ongoing differences in versions but these differences are related not to brand name but rather to

EVERYTHING is here excepting motor drive connections.

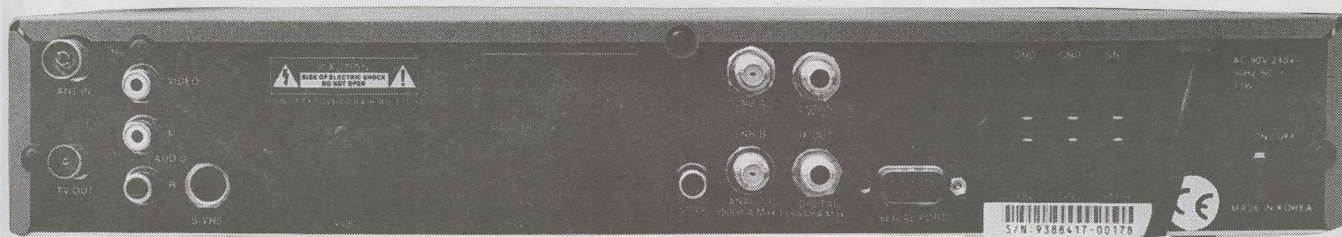

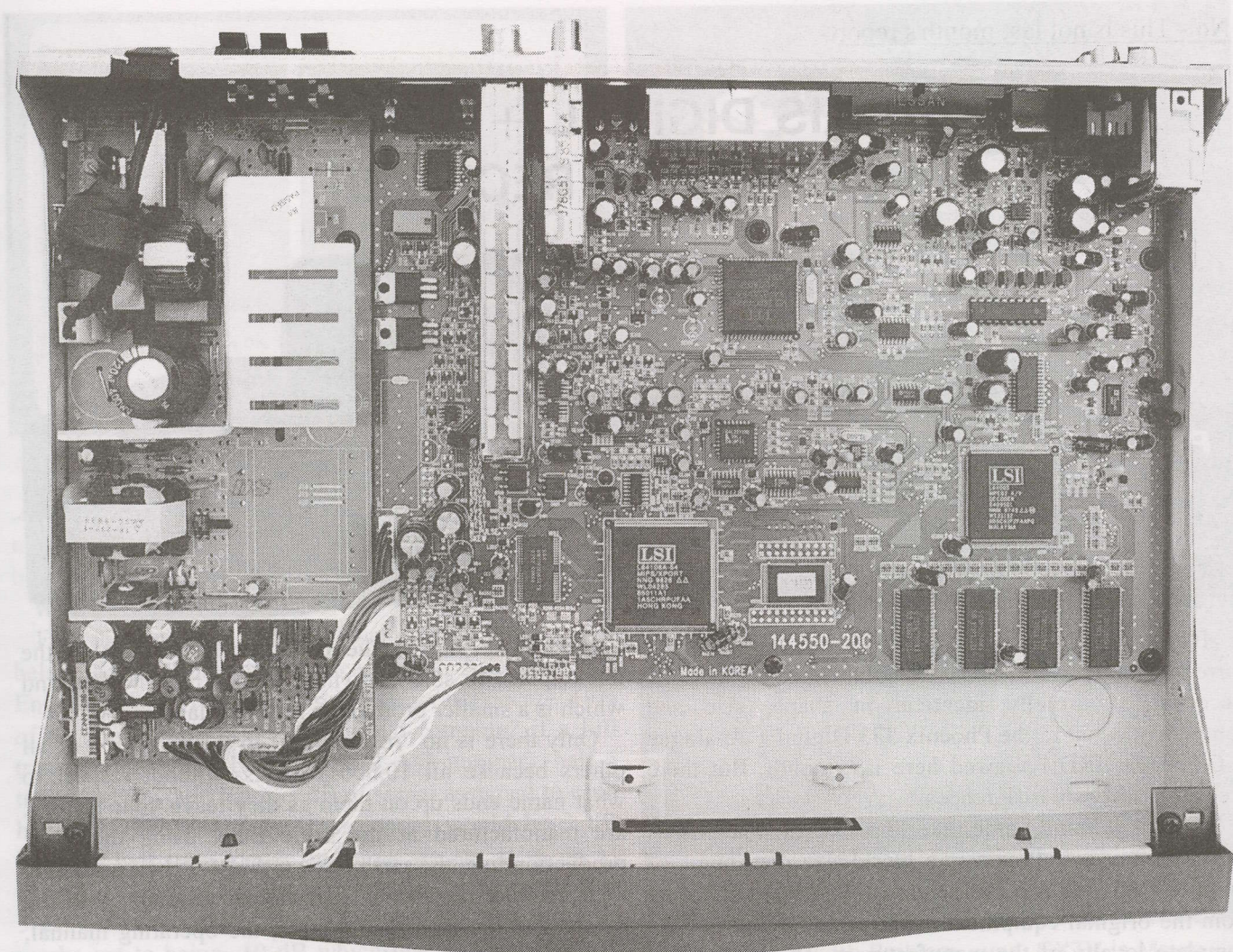

the time of manufacture. At the moment, the influence of world-marketeer Echostar uncertain, Praxis is the "lead buyer" and what they say to the Korean widget maker is what counts. Everyone else in the purchasing process takes whatever Praxis wants because Praxis buys more than any other single distributor.

In our review of the Pheonix/Phoenix 333 in November, we commended the fact this IRD loads everything in sight including some typically very

difficult to load services (such as Myawady). You would expect the 9800 to do the same - *it does*. The 9800 AD does however lack one very important feature found in the 333 - there are no power supply components nor software to allow the user to operate an actuator. In other words, this is a state-of-the-art digital IRD, with a state-of-the-art analogue low threshold receiver that we found performs (as with the Pheonix/Phoenix) as close to perfect as any separate digital and analogue pairs we

It loads the tough ones - such as fTV on 3796/3799 Vt and FTA third programme channel of Sky Racing (4020 Vt), both on AsiaSat 2. They are difficult because levels are low, data streams "dirty."



See more detail

Perhaps the most important specification of a Spectrum Analyser is its Measurement Bandwidth. The narrower the Measurement Bandwidth, the more detail will be displayed on the screen. For satellite TV instruments, typical Measurement Bandwidth might be 9MHz or 4MHz, which is OK for showing a full transponder but not much else.

The new Unaohm EP507 includes Measurement Bandwidth as fine as 100KHz all the way up to 2150MHz! This makes the instrument suitable for VSAT and other communications work as well as Television.

A premium quality colour LCD screen displays spectrum markers in colour, as well as providing green/red go/no go feedback from digital Bit Error Rate measurement options.

The EP507 is a computerised instrument, who's spectrum display properly shows frequency from left to right and level from top to bottom. The computerisation has been implemented with great care so as to increase the range of useful measurement functions. One example is the tuning knob, which is in fact a pulse encoder that assists by providing fast access to menu functions or tuning, by PProgram, CHannel, or FRequency.

A huge range of analogue and digital measurement options make Unaohm's EP507 possibly the best value television measuring instrument available regardless of price.

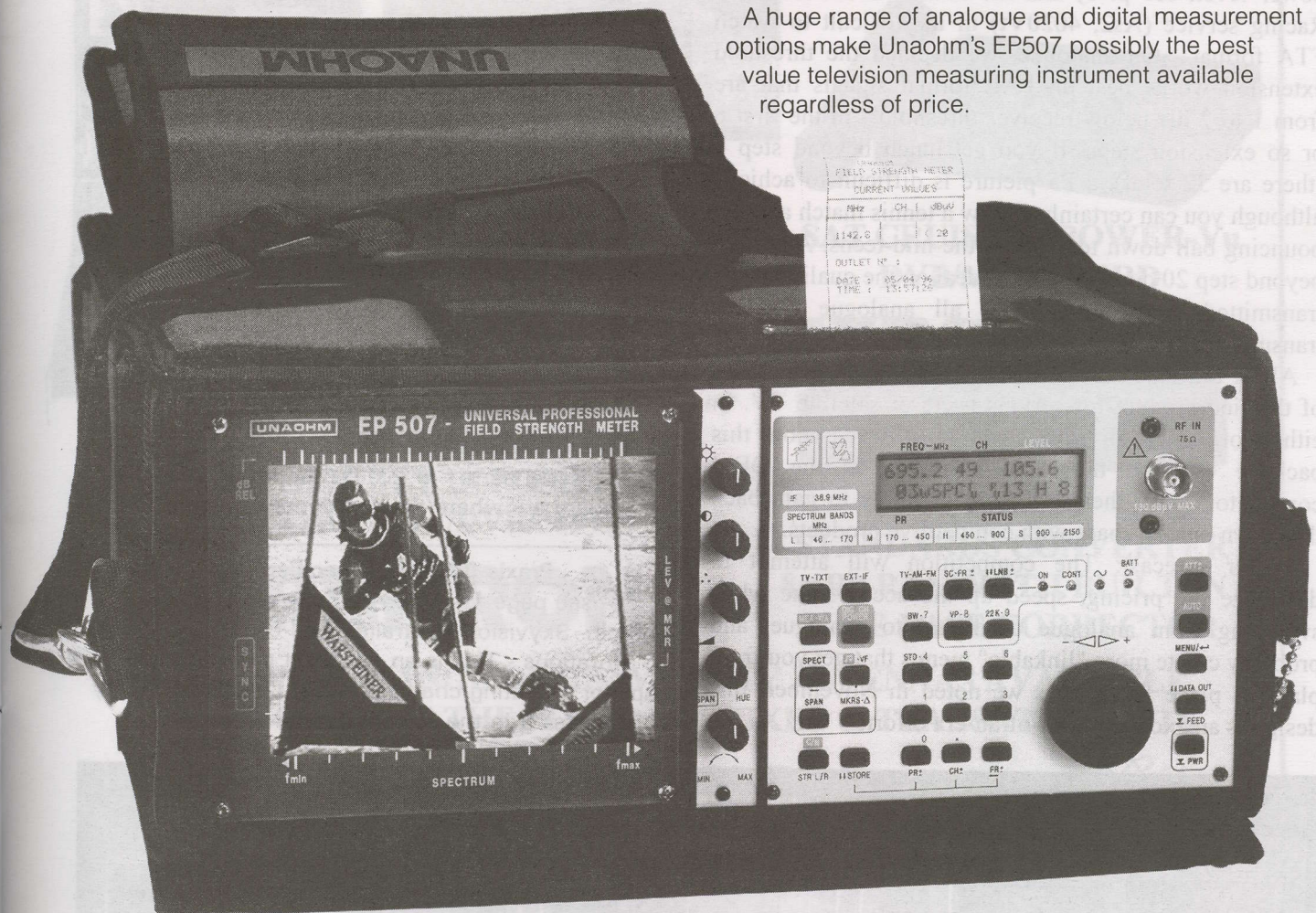

Technical Catalogue available now!

Lacey's
Australia ACN 006 893 438

12 Kitson St. Frankston VIC 3199
Tel:(03) 9783 2388 Fax:(03) 9783 5767
Int+613 9783 2388 Int+613 9783 5767

e-mail: placey@netlink.com.au
Branches in Sydney, Ulverstone & Woolgoolga

have tested. As you might suspect, if your installation requirements do not include supplying power to an actuator and counting the pulses that tell you where the dish is pointed, the 9800 AD comes in significantly less costly than the model with the "P" (positioner) circuits. As a retailer or installer, the 9800 gives you an added way to go - to satisfy the needs of a customer who may not for whatever reason need to control his dish with a built-in positioner.

(This note about the Praxis line from Skyvision Australia - it should not come as a complete surprise to learn they also have the 9800 ADP which is identical to the '333' model offered by a competitor. This fact allows you to do some "comparison shopping" before making your own buy decision.)

Performance ...

It not only looks like a triple-3, it works like a triple-3. The 9800 cares not whether a video source is NTSC or PAL, PowerVu or DVB compliant. It loaded everything we expected to find including the troublesome Fashion TV (and that was before Fashion TV cranked up their power level; see p. 8) and the almost never seen Sky Racing service (As2, 4020Vt) in its difficult to watch FTA format. On analogue, we decided the threshold extension works best on PAL format signals that are from 1 to 2 dB below receiver threshold - in the first 6 or so extension steps. If you get much beyond step 6 (there are 32 total), a P5 picture is difficult to achieve although you can certainly follow a tennis match and the bouncing ball down to steps in the mid-teens. Anything beyond step 20 depends a great deal on the quality of the transmitted signal (no - not all analogue services transmit pristine, well modulated signals).

All of this said, the 9800 AD (or 9800 ADP) is a top of the line product for serious users of satellite TV. In either form (with or without the positioner option) this package will be the "one to beat" as the OEM competitors burn then midnight oil to try to gain back their own market share with competitive products.

Our forecast: The competition will attempt to downsize the pricing, speed up the access time when switching from analogue to digital to analogue, and probably create more "linkable" menus that get you from place to place faster. As we noted in November, this design is an excellent first-of-an-era effort.

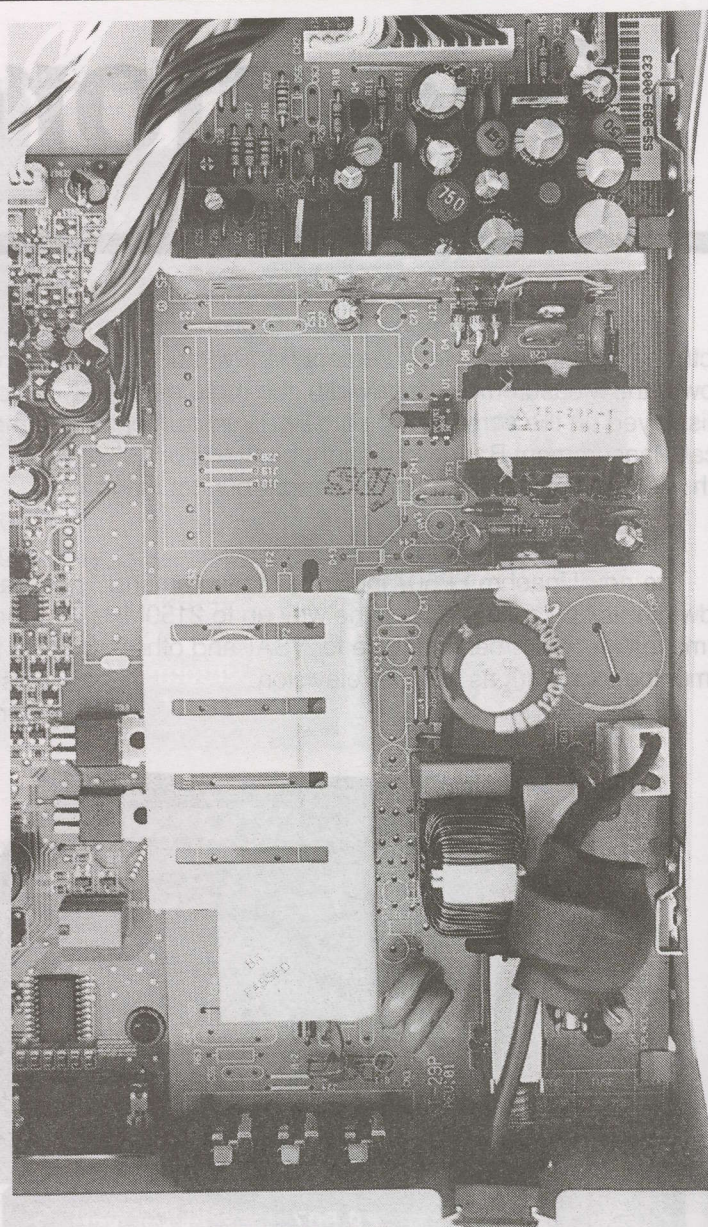

The missing parts - in middle and lower centre of board are where the positioner circuits go

Praxis 9800 AD Specifications

* - see page 14, SatFACTS November 1998
 Source - Skyvision Australia at tel 61-2-6292-5850
 Notations - This is an excellent product with superior operating characteristics. Digital sensitivity rates it in the "top 4" we have tested.

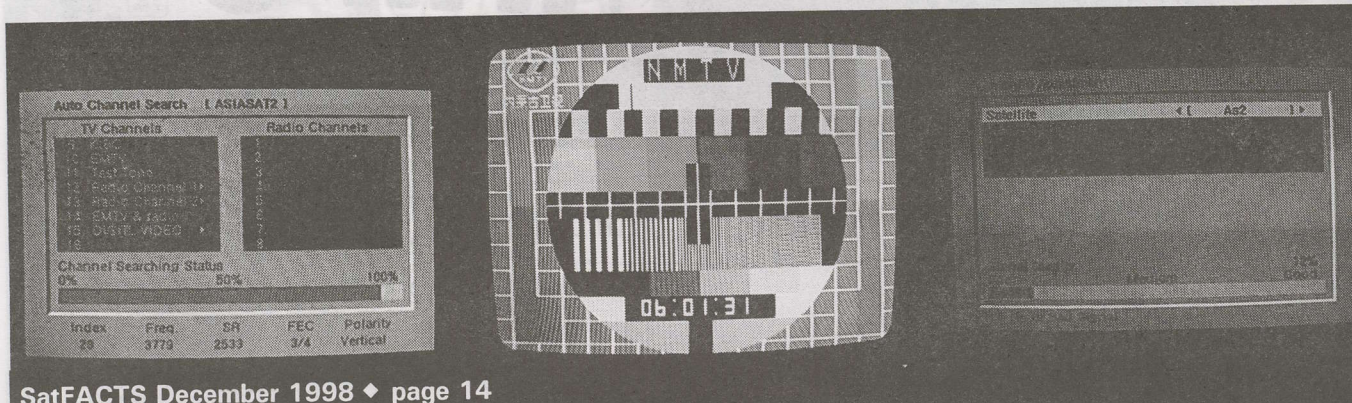



TELSAT™ COMMUNICATIONS LTD.

SATELLITE TELEVISION CONSULTANTS, IMPORTERS AND EXPORTERS

SEASONS GREETINGS



TO ALL OUR VALUED CUSTOMERS MANY THANKS
FOR YOUR SUPPORT THIS PAST YEAR
OUR VERY BEST WISHES FOR A PROSPEROUS 1999



PRODUCTS

FROM THE COMPANY WHO 10 YEARS AGO BEGAN TO
UNSCRAMBLE THE FUTURE

Benjamin

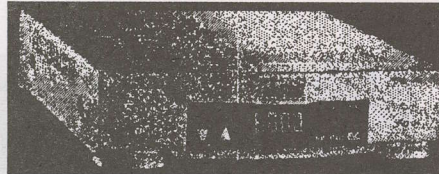

**DB-6000 - POWER-Vu
DVB/MPEG 2 DECODER**

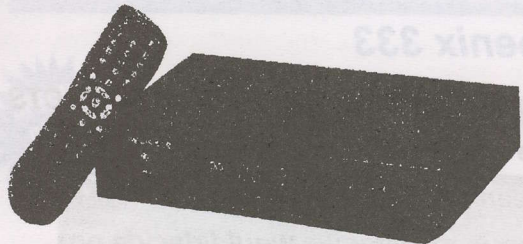

**SAT CRUISER - POWER-Vu
DVB/MPEG 2 IRD**

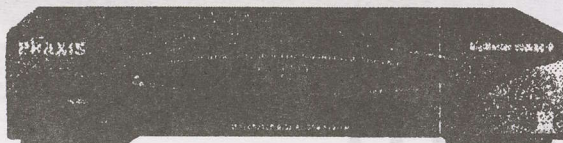

**PRAXIS - DIGIMASTER 9800 AD+P
3 IN 1 DIGITAL, ANALOG IRD
WITH BUILT IN POSITIONER
POWER-Vu/DVB/MPEG 2**

CYP CYPRESS TECHNOLOGY CO., LTD.



**CDM-820
STANDARDS CONVERTER
8mBit RAM WITH BUILT IN
TIME BASE CORRECTOR**

ORBITRON

A NEW RANGE OF HEAVY DUTY ANTENNAS AVAILABLE
INCLUDING THE POLAR "T", FIXED & TRAXSAT MOUNTS

**AVAILABLE FOR LEASE
CHANNEL 56 WHARITE UHF TV LICENSE**

Please Visit our Comprehensive WEB site
Contact us for your FREE 24 page '99 catalogue



17 Westhaven Grove, PO Box 1537, Palmerston North, New Zealand.
Tel: 0-6-356 2749, Fax: 0-6-355 2141, Int'l: +64-6-355 2141, Cellular: 0-21-454 945, Freephone: 0800-TELSAT
Internet Email: telsat@intec.gen.nz Web: <http://www.telsat.com>

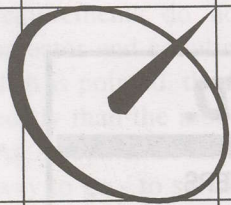

SATECH

Satellite Communication Technology Pty. Ltd.



Phoenix 333

"THE BENCHMARK IN A NEW GENERATION"



Phoenix 333

As quoted in November Issue of SatFACTS
"If we were forced to make a decision
between owning any digital and any
analogue receiver we would decide on
owning the Phoenix 333"

3 in 1 Digital-Analogue-Positioner ✓

High Sensitivity on Digital ✓

Low Threshold on Analogue ✓

Heavy Duty Power Supply for Positioner ✓

Phoenix 111

"REVOLUTIONARY IN COST AND PERFORMANCE"



Phoenix 111



Power Supply and Software
Specially Designed for
Australian Conditions

Digital ✓

High Sensitivity Loop through Tuner ✓

Built in Digital NTSC to PAL Converter ✓

Heavy Duty Power Supply ✓



Sole distributor for Phoenix Worldwide



SATECH

Satellite Communication Technology Pty. Ltd.

Head Office: 6/477 Warrigal Road Moorabbin East Victoria Australia 3189 Ph: 613 9553 3399 Fax: 613 9553 3393

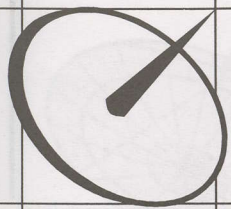

SATECH

Satellite Communication Technology Pty. Ltd.

cables

Times Fibre & Comscope

Huge range of RG6 & RG11

- Dual
- Quad
- Flooded
- Messengered

also 7 core tracking system cable (available by reel or per meter)



SATECH
Distributors for the
Full Range of **CALAMP**

- CALAMP C BAND 25K VOLTAGE SWITCHING LNBF
- CALAMP KU BAND 1dB VOLTAGE SWITCHING LNBF
- CALAMP C/KU BAND POLARIZER FEEDHORN
- CALAMP C BAND DIGI-READY PHASE LOCKED LNB
- CALAMP C BAND MINI-MAG 17K LNB

SPECIAL of the MONTH

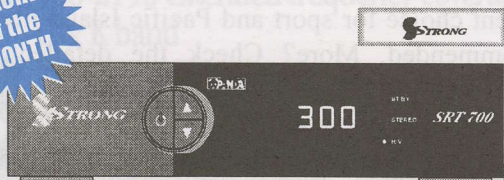

STRONG SRT 700 features

- Stereo Satellite Receiver
- 300 Channels
- C/Ku Band
- On Screen Display
- Low Threshold Tuner (<3.0 dB C/N)
- 3 Digit LED Display
- Direct Local Oscillator Selection
- Adjustable Audio Bandwidth
- 8 Steps Volume Control
- 3 Scarts (TV, VCR, Decoder)

JUST LAUNCHED STRONG'S SRT 350 Call us for best price!

SPECIAL of the MONTH

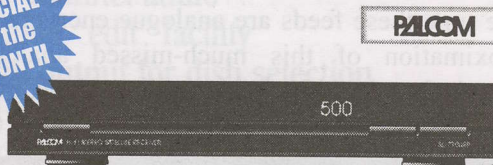

PALCOM SL-7700RP features

- Dual Axis
- Positioner
- Low Threshold
- Auto Focus
- Inclined Orbit Tracking

JUST LAUNCHED PALCOM'S SL-7700RP Call us for best price!

wall plates

SPECIAL of the MONTH

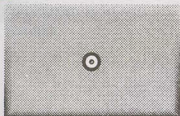

Single "F" outlet plate with bracket SC1301

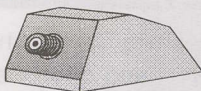

Skirting Board "F" outlet plate SC1302

dishes

SATECH your No.1 Paracclipse distributor for the complete Paracclipse range

Paracclipse Dishes

- Exceptional strength and wind resistance
- Accurate reception

SPECIAL of the MONTH



Paracclipse
HIGH PERFORMANCE ANTENNAS

SATECH
Sales & Enquiries Sydney & NSW

Call Mr Satellite
Josef Pietras
612 9723 7100

All products available through the following SATECH Distributors:-

Southern Satellite - South Australia -Tel: 08 8377 0955

Norsat - Western Australia -Tel: 08 9451 8300

Network Satellite Services - NSW -Tel: 02 9687 9903

Bay Satellite - NZ -Tel: 64 6843 5296

Satech - Head Office Melbourne Victoria -Tel: 613 9553 3399

Satech - Sydney -Tel: 612 9723 7100

FUN and GAMES ON I-180E

Just four years ago, there was no PAS-2 regular service (it had just begun testing) and our Orbit Watch report listed no (zero) digital services and fewer than 20 analogue services available. Of the analogue, 12 were transmitted through Intelsat 180E and the satellite of that era was old, tired, and increasingly inclined in orbit. By the time the tired Intelsat bird was retired (September 1997), virtually all of the I180 analogue video was gone as replacement I701 took up the station. With FTA analogue gone, and new coverage patterns with the 701 satellite, interest in the 180E location has waned.

One of the more important mainstays at this location in analogue was the vidiplexed (two video signals interlaced in an analogue format) USA network feeds from ABC, CBS, Fox and NBC. Some from Fox still show on FTA on occasion at 3930/1220 RHC but 90% of the time these feeds are analogue encrypted. A close approximation of this much-missed analogue FTA service is found within the Australian 10 MCPC bouquet (see table, above) where news feeds from CNN and

Service	Frequency/ Polarity	Msym	FEC
TOM/Canal+	4095/1055L	27(.500)	3/4
RFO Tahiti	3858/1292L	4(.566)	3/4
SPN Nauru	4081/1069R	4(.730)	3/4
USA Vidiplex +	3930/ 1220R	Analogue	usually encrypted
Australian 10	3765/1385R	29(.900)	7/8

others, USA network shows and syndicated programming is transmitted in FTA MPEG-2 (although NTSC).

Equally interesting are the five video signals (plus 8 radio) within the TOM/Canal + bouquet. Saudi TV is pretty tame but Abu Dhabi carries USA movies subtitled in their local language (English audio is intact). SPN is an excellent choice for sport and Pacific Island lifestyle and recommended. More? Check the detailed I180 listings on pages 26 (digital) and 28 (analogue) in this issue. I180 is alive and well!

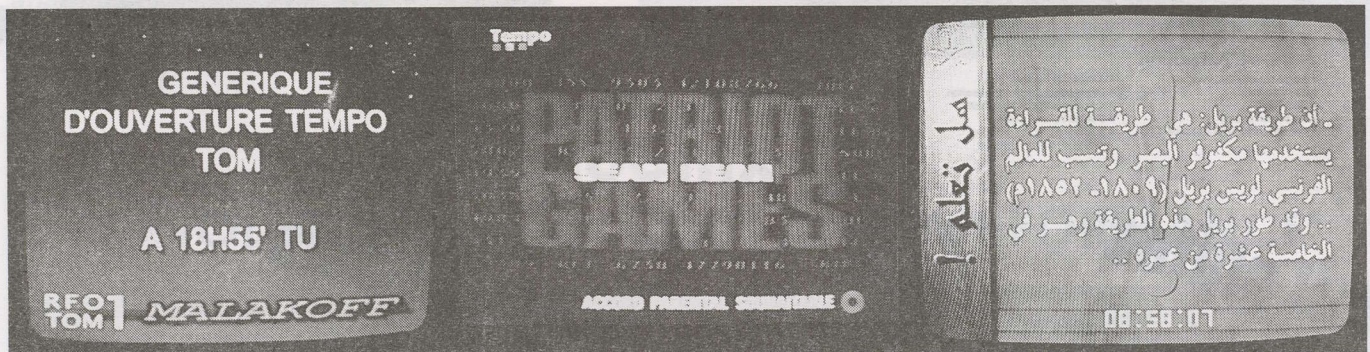

ABOVE - LHC 4095/1055 RFO/Canal + bouquet includes trio of French service feeds from Paris to Pacific (left hand and middle photo) as well as Saudi TV (right hand photo) and Abu Dhabi TV (not shown).

BELOW - CNNI news feeds, Oprah's USA same-date show, Jerry Springer and evening network feeds of USA prime-time shows are on 3765/1385 RHC (this is a circular, not linear, satellite!).

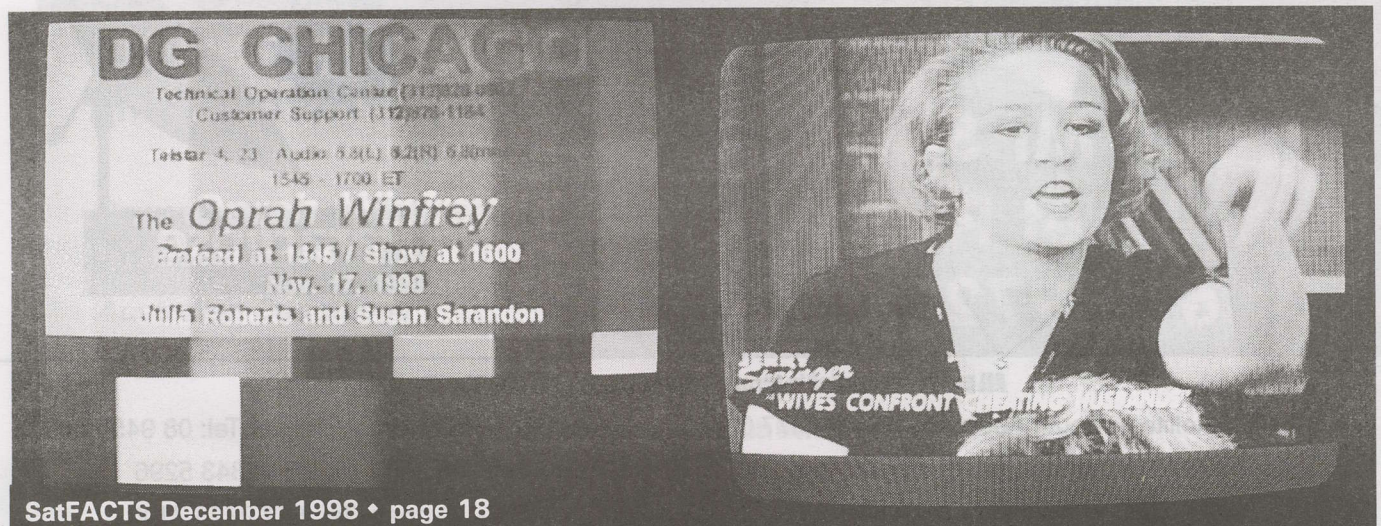

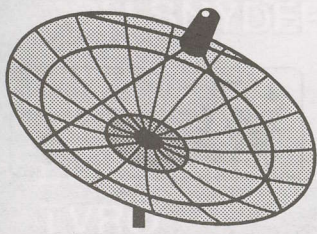

AV-COMM SATELLITE TV EQUIPMENT

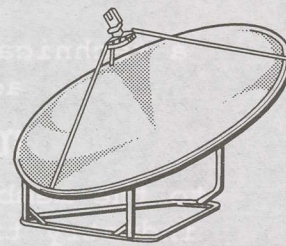

FREE TO AIR DIGITAL SATELLITE RECEIVER R3100

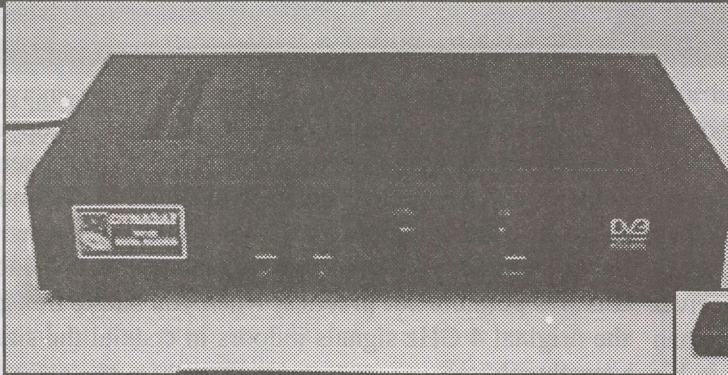

Cat # R3100

ONLY
\$1145

Call
for
export
price

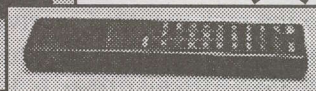

FEATURES

- ◆ 950-2150 extended frequency coverage, C & K band
- ◆ 14/18V LNB polarity selection
- ◆ MCPC & SCPC
- ◆ 22KHz tone switching for dual input ops.
- ◆ Downlink signal margin indicator
- ◆ Dual channel audio
- ◆ Channel "edit" facility
- ◆ 0-12V output for dish selection
- ◆ S-VHS video output
- ◆ Auto FEC detect

DYNALINK MANUAL TUNED RECEIVER R1100

SPECIFICATIONS

- ◆ 950 - 2050MHz IF Input range
- ◆ Low threshold operation
- ◆ Stereo audio
- ◆ 14/18V LNB switching
- ◆ 18/27MHz IF Bandwidth.

Ideal for band scanning, channel monitoring, or as the heart of any home satellite receiving system.



ONLY
\$199

Call for
export price

Cat # R1100

AV-COMM PTY. LTD.

DIRECT IMPORTER ACN 002 174 478
PO BOX 225, BALGOWLAH 2093

TEL: 61 2 9949 7417 9948 2667

FAX: 61 2 9949 7095

VISIT OUR WEB SITE AT

<http://www.avcomm.com.au>

*We reserve the right to improve product performance without notice.

✓YES GARRY, Please send me more info...

Name: _____

Address: _____

_____ P'code: _____

Phone: _____

a technical and marketing
advisory
memo
to the membership from your
industry trade association

SPACE Pacific

Satellite
Programme
Access
CommittEe



A trade association for users, designers,
installers, sellers of private satellite-direct
systems in the Pacific Ocean & Asia Regions

The first "home" satellite receiver was created at a time (1978) when only two commercial receivers existed (SA and Microdyne; Hughes came along later). Commercial receivers used an LNA (low noise amplifier) where we now use an LNB (low noise block down converter) and the 4 GHz (microwave) energy was carried from the LNA to the rack mounted receiver through 7/8" coaxial line (slightly larger around than your thumb). Co-developers Steve Richey (that is his lap holding the receiver, lower left) and Rod Wheeler looked for a way around this problem and came up with

a technique to block down convert the 4 GHz energy to an IF band (they selected 400-900 as their first option). The advantage was obvious - now smaller (RG-6 series) cable could be used to connect the dish to the indoor receiver. And, multiple receivers could be stacked up using common garden variety signal splitters. None of this was possible nor practical when you had to transport the original 4 GHz signals indoors in coaxial the size of your thumb.

So great was this innovation that Richey had his life threatened at a trade show by a person who correctly

The very first home style satellite receiver (left) was designed by cable TV engineer Steve Richey and Canadian TVRO pioneer Rod Wheeler for Northern Satellite Systems (later became Norsat). It included some innovative signal processing circuits the "professionals" at Scientific Atlanta and Hughes had not yet worked out including the first use of PLL (phase lock loop) demodulators, created initially by English TVRO pioneer Steve Birkill (right).



MEMBERSHIP IN SPACE

Membership in SPACE Pacific is open to any individual or firm involved in the "satellite-direct" world in the Pacific and Asia regions. There are four levels of membership covering "Individuals," the "Installer/Dealer," the "Cable/SMATV Operator," and the "Importer/Distributor/Programmer."

All levels receive periodic programme and equipment access updates from SPACE, significant discounts on goods and services from many member firms, and major discounts while attending the annual SPRCS (industry trade show) March 24-27 [1999] in New Zealand. Members also participate in policy creation forums, have correspondence training courses available. To find out more, contact (fax) 64-9-406-1083 or use information request card, page 34, this issue of

SatFACTS. Page space within SatFACTS is donated each month to the trade association without cost by the publisher.

TOM SNYDER
and
NBC
DISCOVER
TVRO

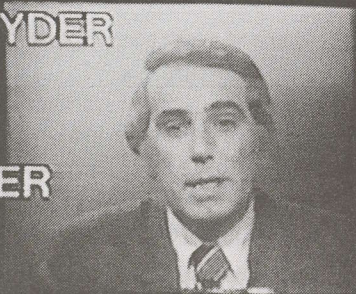

DECEMBER 23, 1979

In his late December (1979) prime time NBC programme, Tom Snyder described the "ultimate Christmas gift" of the year - a home satellite dish system.

predicted, "Now, *everyone* can have one of these damned things." This person was a cable-guy, and not pleased at the prospect. All of this and more is on videotape as you will soon see on SPACE Pacific Reports when the TV series launches on satellite early in 1999.

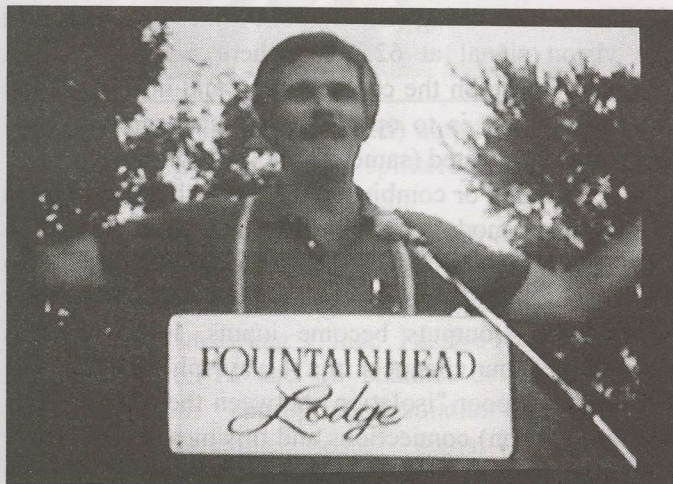

Programming pioneer Ted Turner (Super Station, CNN, TNT, Cartoon Network) responding to applause at 1978 trade show (above) and receiving award recognising his support of satellite distributed TV from a strangely familiar guy on right.



COOP'S TECHNOLOGY DIGEST

TEN issues each year, each with a theme report followed by a world-wide roundup of everything important in the field of satellites and telecommunications.

✓ December 04 issue -

A critical look at the new B SkyB 2200 series Pace IRD and its little brother, the Sky NZ DSR 620. All is not well with this new technology.

✓ October 30 issue -

Iredeto has been busted. By whom, where, and how are they marketing their grey mark creations? It's all here with Web Site addresses.

If you are not reading CTD, you are getting only half the story!

Coop's Technology Digest (CTD) is now into its sixth year of providing a total world-wide synopsis of the latest developments, trends and events that make telecommunications the greatest growth industry the world has ever known. If you are in the satellite business, you need CTD!

Subscription form page 33 at back of this issue

ATTENTION: SPACE PACIFIC MEMBERS

Volume 4, Number 3 of SPACE Membership Notes is scheduled to go into the mails to you around December 20th. This issue discusses the mechanics of satellite signal encryption and provides you with detailed information that should assist you in your own comprehension of the challenges facing our industry as piracy of encrypted digital services becomes common place.

Piracy is a moral and business issue which cannot be ignored. The future of our industry and your own business may ultimately depend upon how fast programmers are able to get piracy under control. SPACE feels the better you understand encryption, the closer you will be to dealing with the threat of piracy.

The CABLE Connection

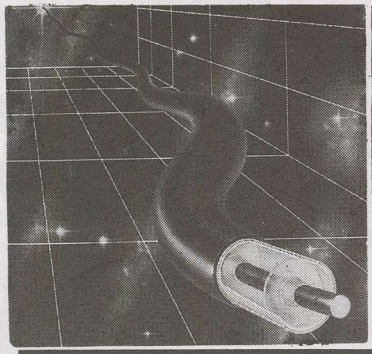

It is not very impressive looking - a (12) channel "Combiner" allows you to mix the outputs from up to 12 separate CATV/SMATV modulators into a single output line for connection to a distribution system.

Combining Channels

The concept of mixing two or more TV programme channels together on one piece of (coaxial) cable relies on the ability of the (TV) receivers connected to that line to separate programme channels by their operating frequency. The channel selection knob of the TV set activates a set of tuned circuits, one set per TV channel. The TV set tuner is a frequency selector capable of picking one TV programme out of many that coexist on the same cable simultaneously. The same principal applies to the transponder / channel / frequency selector of your satellite receivers.

However, the consumer television set is a cost effective device and the range of "selectivity" built into it is limited by the economics of competition in the TV set manufacturing business. This means that great care must be taken when "mixing" channels together to ensure the relatively simple channel selection system built into the TV set remains capable of separating signals one channel at a time.

Individual Channel Settings

Standard practice in the TV broadcast industry is to operate the aural (sound) transmission power at a level 6 to 10 dB below the vision carrier. Recovery of sound with picture requires far less signal to the TV receiver simply because the bandwidth of the sound is very small

in comparison to the vision. The narrower the bandwidth, the less transmission power required.

For cable distribution, the sound carrier level can be reduced even further and still provide very high quality sound. In a cable distribution system with immediately adjacent channels in use (such as 55.25, 62.25, 69.25), the sound needs to be reduced in carrier level to a point where it is 15 to 17 dB below the vision carrier. These adjustments are found on all quality modulators and you "read" the actual carrier levels on a spectrum analyser or signal level meter. If you fail to reduce the aural carrier by 15 to 17 dB, the TV set trying to receive a vision carrier at 62.25 finds the lower adjacent channel sound (centred at 60.75) overpowering and the sound from 60.75 creates waving (herringbone) lines or patterns in the vision signal at 62.25. If there are no adjacent channels in use on the cable system, and none ever will be, the practice is to operate the sound carrier 10 dB below the associated (same channel) vision carrier.

When mixing or combining channels, the first concern is that each modulator (signal source) "looks into" a proper termination impedance. In theory it is possible to combine two channels using a two-way splitter "backwards" (outputs become inputs, input becomes output) and four channels in a 4-way splitter. However, there is very poor "isolation" between the two input (in this application) connections and this means each of the two modulators is "looking at" the other modulator in

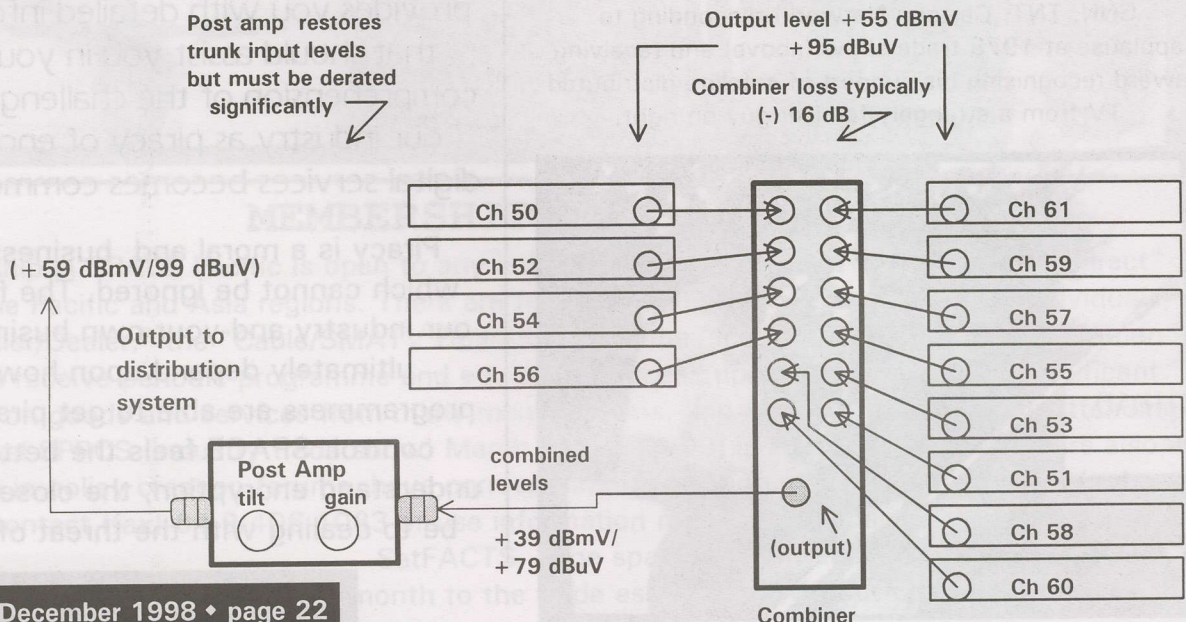

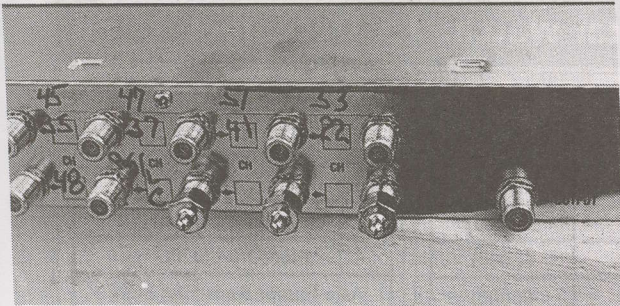

12 F-connector inputs (10 are shown here) with single F-connector output (fitting at lower right). Note use of 75 ohm F-fitting "terminators" on 3 unused ports at lower right.

9 of 12 ports on this combiner are in use; output will connect to unused port at lower right. Cable should be high density double shielded to eliminate "cross-talk" between closely spaced connectors.

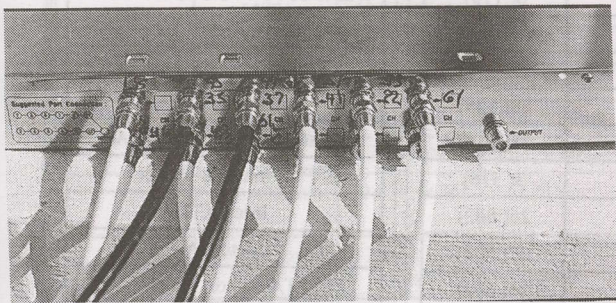

addition to the single (combined) output line. Suffice to say, combining channels with splitters used "backwards" is a poor approach to this problem.

Passive combiners from sources such as Winersat (1) overcome the isolation problem and allow each modulator to "see through" the device to only the common output fitting / line. Passive combiners are available as 8, 12 and 16 channel devices. A good combiner with appropriate isolation and quality impedance matching "loses" signal between the individual input ports and the all-channels-combined common output. There is no such thing as a free lunch - when you combine properly, there *is* signal loss (typically 16 dB in a 12 channel combiner). The diagram on p. 22 shows that a 95 dBuV (55 dBmV) modulator passing through a 12 channel combiner comes out at 79 dBuV (39 dBmV).

If you have 16 or fewer channels, a "headend combiner" can be a single unit. More than 16 channels and some combination of 8, 12 or 16 channel combiners is required, followed by yet another combiner to combine the combiners! The system diagrammed here is a part of a 65 channel system using 6 x 12 way combiners that are in turn recombined in an 8 way.

As each combiner contributes loss or attenuation, the common practice is to place a "post" (as in "after the combiner") amplifier in the line to raise levels back to a level suitable for cable distribution.

1/ Winersat WPC-8, WPC-12 and WPC-16

SURPLUS TO OUR NEEDS

-You may be able to use these!-

Analogue Format Satellite Receivers

- The ultimate professional receiver. SA 9708 designed for B-MAC and FTA analogue. Exceptional video output for driving cable, SMATV, rebroadcast systems. Rack mountable, fully agile (950-1450), includes polarisation control. These cost US\$2,000 + when new. Two units, US\$250 each + shipping.
- Winersat WCR-100 rack mount covers 950-1450, two audio channels fully tuneable, audio and video bandwidth. Super buy to set up your own cable or SMATV headend - 10 units at US\$50 each + shipping.
- (RL) Drake professional ESR 1255 does everything you need done from adjustable bandwidths to threshold extension. Rack mount, LCD menu display, top of the line (original US\$1,200+) for US\$250 + shipping.

Cable TV Modulators

- Winersat WAM 500SL frequency agile, dial up virtually any frequency between 40 and 550 MHz. Rack mount, full control of audio, visual carrier and modulation levels. One deluxe machine - typically US\$550, US\$200 + shipping.
- PX SA-65 rack mount, quality adjacent channel rack mount modulator. Two units - S26 (343.25) and S34 (407.25). Factory new, US\$100 each + shipping.
- Blonder Tongue rack mount cable quality units:
 - ♦ MAVM-S / ch. S5 (133.25) US\$75, BAVM / ch. E2 (48.25) US\$100, BAVM / ch. E3 (55.25) US\$100, BAVM / ch. E6 (182.25) US\$100 (all + shipping)

Cable Off-Air Signal Processors

Off-air VHF (and UHF) signals to be cable carried must be processed to separate one channel from off-air adjacents, then amplified and filtered for constant output levels. This is the professional way to get off-air channels onto cable.

Note specific channelling of (some) units.

- Winersat WAP 600SL agile processor. Dial up any input frequency (40 - 890 MHz) and any output frequency (40-550 MHz) and you are away. IF looping, full adjustments for everything important. US\$300 + shipping.
- BT B4454 single channel processor (E10/E10, 210.25), rack mount, full user controls. US\$100 + shipping.
- BT model ESHP processors as follows: (1) E9 (203.25) in / S3 (119.25) out; (2) E7 (189.25) in / S2 (126.25) out; (3) E5 (175.25) in / S4 (133.25) out. Rack mount, full set-up controls. US\$150 each + shipping.

We buy - and sell - surplus cable TV equipment. Tell us your needs - looking for functioning Irdeto-CAM-equipped IRDs!

Far North Cable TV Ltd.

(tel) 64-9-406-0651 • (fax) 64-9-406-1083

SatFACTS December 1998 • page 23

SatFACTS Pacific/Asian MPEG-2 Digital Watch: 15 December 1998

BIRD	Service	RF/IF & Polarity	# Program Channels	FEC	Msym	
I703/57E	Sky News (BSkyB feed)	4187/963R	1	3/4	5(.632)	
		4140/1010R	1	3/4	5(.632)	
	Occ. feeds	4055/1095L	1+	3/4	27(.500)	
	CNBC	4018/1132L	1	3/4	6(.000)	
	CNBC	3795/1355L	1	2/3	6(.000)	
I704/66E	TV5	4055/1095R	4	3/4	27(.500)	
		Sky News +	3805/1345R	4	3/4	22(.520)
	CNBC	3795/1355L	1	2/3	6(.000)	
PAS4/68.5E	Nickelodeon +	4155/955H	1 reported	1/2	24(.000)	
	BBC	3743/1407H	5	3/4	21(.800)	
	CCTV	3716/1434H	up to 6	3/4	19(.850)	
Ap2/76E	Sun Movies	3695/1455V	1+?	?	?	
	HMark/Kermt	3720/1430H	4	3/4	19(.510)	
	Plus 21/Adult	3787/1362H	1	3/4	6(.110)	
	Baccarat	3836/1314H	1	3/4	3(.184)/6(.111)	
	TVB-8 +	3849/1301H	4	3/4	13(.238)	
	Disney	3880/1270H	3	5/6	28(.125)	
	AXN	3920/1230H	up to 8	7/8	28(.340)	
	Vietnam	12.696V	1	3/4	3(.516)	
	Them3/78.5E	UTV	3920/1230H	6	3/4	26(.662)
		UTV/MCOT	3880/1270H	8	3/4	27(.500)
		Maharishi	3600/1550H	up to 8	3/4	26(.662)
Myanmar TV		3666/1484H	1	3/4	4(.442)	
TV Maldives		3460/1690V	1	3/4	6(.312)	
Thai Global +		3425/1725V	up to 8?	2/3	27(.500)	
As2/100.5E		Chinese Tests	12.295,329H	1TV each	2/3, 1/2	6(.103/.930)
		(#1) Euro Bouquet	4000/1150H	6TV,12r	3/4	28(.125)
	Hubei/HBTv	3854/1296H	1	3/4	4(.418)	
	Hunan/SRTC	3847/1303H	1	3/4	4(.418)	
	Guan./GDTV	3840/1310H	1	3/4	4(.418)	
	Inn Mongolia	3828/1322H	2	3/4	4(.418)	
	APTn A-O	3799/1351H	1	3/4	5(.631)	
	WTN Jer/Lon	3790/1360H	1	3/4	5(.631)	
	APTn A-P	3786/1364H	1	3/4	5(.631)	
	WTN/Reuters	3775/1375H	1	3/4	5(.631)	
	Reuters M-E	3770/1380H	1	3/4	5(.632)	
	Liaoning/Svc2	3734/1416H	1	3/4	4(.418)	
	Jiangxi/JXTV	3727/1423H	1	3/4	4(.418)	
	Fujian/SETV	3720/1430H	1	3/4	4(.418)	
	Quinghai TV	3713/1437H	1	3/4	4(.418)	
	Henan /Main	3706/1444H	1	3/4	4(.418)	
	As2/100.5E	Sky Racing	4020/1135V	3	1/2	18(.000)
EMTV		4006/1144V	1TV, 2radio	3/4	5(.632)	
KIBC		3940/1210V	1TV, 4 data	2/3	26(.655)	
STAR/ISkyB		3900/1250V	19TVw/3744	7/8	26(.845)	
BSkyB		3865/1285V	8+	7/8	26(.845)	
HeiLongJiang		3834/1316V	1	3/4	4(.418)	
JSTV		3827/1323V	1	3/4	4(.418)	
Shaanxi/QQQ		3813/1337V	1	3/4	4(.418)	
Guang GXTV		3806/1344V	1	3/4	4(.418)	

Receivers and Errata
NDS encrypted
FTA (global beam)
Feeds-FTA SCPC
Asia-Europe feeds-FTA SCPC
FTA
Sky News 24 hr, sport, feeds FTA?
FTA SCPC
Testing; also try 26(.000)
FTA
FTA
FTA - may be test
PowVu typ CA; Kermit temp FTA
Was to be PowVu CA; not active?
FTA
PowerVu CA
PowVu CA
Tests, promos, some FTA
FTA national service
Irdeto CA
Irdeto CA
FTA - short hours?
FTA - may be only test
FTA - Testing - Asian beam
FTA
FTA (mainland only beam)
FTA
FTA SCPC
FTA SCPC
FTA SCPC
FTA - #1 Chinese, #2 Mongolian
FTA SCPC
Mostly CA SCPC, some FTA
Reported shut down- card only
Some FTA SCPC
Some FTA SCPC
FTA SCPC
FTA SCPC
FTA SCPC
FTA SCPC
FTA SCPC
NDS DVS211 CA (ch.3. occ. FTA)
PowVu CA-very poor signal level
FTA 1 video ch; ZakNet data CA
NDS CA (Pace DVS211)
NDS CA (Pace DVS211)
FTA SCPC
FTA SCPC
FTA SCPC
FTA SCPC

BIRD	Service	RF/IF & Polarity	# Program Channels	FEC	Msym
(As2/100.5E)	Fashion TV	3796/1354V	1	3/4	2(.533)
	Eastern TV	3785/1365V	5	3/4	18(.000)
	Myawady TV	3766/1384V	1	7/8	5(.080)
	STAR/ISkyB	3744/1406V	35TVw/3900	7/8	26(.845)
	Star TV Sports	3700/1450V	5	3/4	27(.500)
Cak1/107.1E	Indovision S-band	2.530, (.536, .543, .566, .596, .656)	up to 8 per transponder	5/6	20(.000)
Sinoat 1/110E	Shanghai TV	4106/1044V	1	2/3	6(.200)
C2M/113E	Mega TV	3780/1370V	5?	3/4	27(.500)
	Star Indovisi'n	3500/1650H	20w/3580?	7/8	26(.850)
Them 1/120E	ITV Thailand	3760/1390V	up to 8	?	?
AP1/138E	Reuters	3732/1418V	1	3/4	5(.632)
	Reuters	3742/1408V	1	3/4	5(.632)
	Taiwan Bqt	3800/1350H	up to 8	3/4	26(.697)
	MTV	3860/1290V	1	3/4	3(.000)
	Sports	3914/1236V	1	3/4	5(.680)
	CNNI	3980/1170V	2+	3/4	26(.000)
	Optus B3/156	Aurora	12.595V	10+, 9 radio	3/4
	Aurora	12.407V	10+, 9 radio	2/3	30(.000)
	Optus Vision	12.438(.626) H	8TV	3/4	29(.473)
	Austar/Foxtel	12.438(.626, .688)	20TV, 11 radio	3/4	29(.473)
Optus B1/160	Aurora test	12.377H	5+	2/3	30(.000)
	Sky NZ	12.391(.418)V	7 + 7	3/4	22(.500)
PAS-2 169E	GWN Perth	12.265V	6TV, 7 radio	1/2	16(.200)
	Telstra Bend.	12.300V	2	1/2	21(.997)
	Yumin/Taiwn	12.325V	1+	3/4	8(.888)
	IHUG (NZ)	12.408V	0	3/4	5(.333)
	IHUG (NZ)	12.448H	0	3/4	20(.555)
	ABC Interchange	12.629, (.638, .646)V	1 TV each	3/4	6(.980)
	Mediasat	12.655V	1TV	1/2 & 3/4	6(.610)
	Maharishi	12.664.5V	1TV	1/2	3(.300)
(#2)	HK PowVu	4148/1002V	up to 8	2/3	24(.430)
(#3)	NBC HK	4093/1057V	5 typical	3/4	29(.473)
	JET Singapore	3962/1188V	2	1/2	13(.740)
	ESPN USA	3860/1290V	7TV, 2 data	7/8	26(.470)
(#4)	Middle East	3778/1372V	4	3/4	13(.331)
	Service 1	3761/1389V	1	3/4	6(.620)
	BBC + TFC	3743/1407V	5	3/4	21(.800)
(#5)	CCTVPowVu	3716/1434V	4 typical	3/4	19(.850)
	Feeds	4189/961H	1 or 2	7/8	6(.600)
	TCS-Singap.	4183/967H	2	1/2	6(.620)
	ITJ-Jap.Tel.	4174/976H	1	3/4	5(.632)
	Feeds	4138/1012H	1	3/4	6(.620)
(#7)	NHK Joho	4035/1115H	5TV, 1 radio	3/4	26(.470)
	CNNI HK	3996/1154H	1TV	3/4	9(.998)
	7-day Adven	3966/1184H	1	3/4	7(.000)
	PAS-2 feeds	3939/1211H	2 (NTSC)	2/3	6(.620/7.498)
(#8)	Cal PowVu	3901/1249H	up to 8	3/4	30(.800)

Receivers & Errata
Temp FTA- see notes p. 6 here
PowVu CA -#5 FTA; off-air?
FTA SCPC - difficult
NDS CA (Pace DVS211)
NDS CA (Pace DVS211)
RCA/Thompson IRD, typically 1 or 2 FTA test signals can be seen
FTA SCPC
unknown encryption format
Pace(DVS211-Thomson) CA
FTA
FTA SCPC
FTA SCPC
FTA MCPC
FTA SCPC
FTA SCPC
CNN FTA
CA, \$50 smart card required
CA, \$50 smart card required
Pgm chs mixed within Austar bqt; CA; sold separate from Austar
DGT400 CA except #12 and 24
CA, may be inactive
NDS CA, 12.391 primary
PowVu CA (D9234)
PowVu typ. CA (D9223 only)
reported FTA-China beam
Internet data; some video tests
No service table; data only
format PowVu, nominally FTA; recent changes
FTA, occasional service, feeds
FTA, strong to NZ
PowVu, mostly CA, some FTA
Philips mux format FTA
PowVu CA
PowVu CA; avoid #8,9 w/9223!
FTA -0hard to load
occ feeds, FTA SCPC
PowVu; CA and FTA (BBC#3)
FTA (# pgm chs varies)
Test cards, may be feeds
PowVu FTA MCPC
occ feeds, FTA SCPC
FTA SCPC
1 CA (D9234), 4 FTA
FTA - occasional feeds
FTA for Net 98
FTA (NBA basketball, NTSC)
Some CA, some FTA (NTSC)

SatFACTS Digital Watch: Supplemental Reference Data / December 1998

PAS-2/169E	Disney	3804/1346H	3	5/6	21(.093)
	Discovery Sing	3776/1374H	8	3/4	21(.093)
	Satcom 1-6	3743/1407H	6	7/8	19(.465)
I702/177E	AFRTS	4177/973L	8TV, 12r.+	3/4	26(.694)
	Thai Bouquet	12.650H	up to 3 TV	1/2	17(.800)
I701/180E	TVNZ Gennet	4195/955R	1 (CA)	3/4	5(.632)
		4186/964R	BBC/Gennet	3/4	5(.632)
		4178/972R	1 (CA)	3/4	5(.632)
		4170/980R	APT-N-Tokyo	3/4	5(.632)
		4120/1030R	1	3/4	5(.632)
(#9)	RFO-Canal+	4095/1055L	up to 7TV, 5 r.	3/4	27(.500)
	SPN Nauru	4081/1069R	1	3/4	4(.730)
	Baccarat	4028/1122R	1	5/6	3(.702)
	NZ Prime TV	4024/1126L	1	2/3	6(.876)
	RFO direct	3858/1292L	1	3/4	4(.566)
	TVNZ TL	3854/1293R	1	3/4	5(.632)
	TVNZ	3856/1294R	1	3/4	5(.632)
	TVNZ	3846/1304	1	3/4	5(.632)
	10 Australia	3765/1385R	6	7/8	29(.900)

PowVu (D9234) CA
PowVu (D9234) CA
PowVu(D9234) CA
PowVu (D9234) CA
FTA, replaced Space TV
DMV/NTL CA, all channels occ. use, FTA irregular around special event coverage
<was MTV Europe)
Canal + (2) CA, rest FTA
FTA SCPC; weak signal
FTA SCPC; NTSC, short hrs
PowVu CA; network feeds
East hemi beam to Tahiti
SCPC mixed FTA , CA feeds
SCPC mixed FTA , CA feeds
SCPC mixed FTA , CA feeds
PowVu CA; #5 occ FTA

Bouquets: MCPC (multiple [program] channels per carrier) MPEG-2 content frequently changes. Primary FTA (free to air) MCPC bouquets are as follows: 1) **European Bouquet:** (1) **Deutsche Welle**, (2) **MCM**, (3) **RAI International**, (4) **RTVE** (Spain), (5) **TV5 Paris** + up to 13 radio (some stereo); 2) **Hong Kong PowVu:** (5) **Ad Hoc NTSC feeds**, (6) **Ad Hoc PAL feeds**; (3) **NBC HK** (Hong Kong): (1) **CNBC Asia**, (2) **CNBC Australia**, (3) **National Geographic [English]**, (4) **NBC feeds**, (5) **National Geographic [subtitled Taiwan]**; (4) **Middle East [testing]**; (1) **Antenne 1**, (2) **Lebanon LBC**, (3) **ART Australia**, (4) **RAI Australia**; (5) **CCTV PowVu:** (1) **CCTV4**, (2) **CCTV3**, (3) **CCTV 9**, (4) **test bar**; (7) **NHK JoHo:** (1) **NTSC Japanese**, (2) **NTSC English**, (3) **PAL Japanese**, (4) **PAL English**, (5) **NHK Radio**, (6) **NHK Premium**; (8) **Cal PowVu:** (1) **CMT [NTSC]**, (2) **Ad-hoc [NTSC]**, (3) **ART**, (4) **EWTN** + Global Catholic Radio, (5) **BBC World [NTSC - to Oct. 31]**, (6) **Bloomberg Financial [NTSC]**, (7) **Golf Channel [NTSC]**, (8) **Discovery**; (9) **RFO-Canal+:** (1) **Canal+ [Polynesia]**, (2) **Canal+ [New Caledonia]**, (3) **Saudi TV**, (4) **Abu Dhabi TV**, (7)

MPEG-2 DVB Receivers: (Data believed accurate; we assume no responsibility for correctness!)

AV-COMM R3100. FTA, excellent sensitivity (reviewed SF May 1998). Av-Comm Pty Ltd., tel 61-2-9949-7417
Grundig DTR1100. Mfg by Panaset S. Africa, similar to Panaset 630; out of production, Irdeto capable (see AV-Comm, above)
Hyundai-TV/Com. HSS-100B/G (Pacific) and HSS-100C (China) FTA. Versions 2.25/2.26 good performers, 3.11 currently offered and those with Nokia tuners good performers. Version 5.0 not so good. SATECH ([V2.26] 61-3-9553-3399), Skandia ([V3.11] 61-3-9819-2466), Skyvision Australia ([V3.11, Nokia] 61-2-6292-5850).
MediaStar D7. FTA, preloaded with known services, exc. software (review SF July 1998). MediaStar Comm. Int. (61-2-9618-5777)
Nokia "d-box" (V1.7X). European, FTA, typically German menu, capable of "Dr. Overflow" Internet updates. **Caution on this one!**
Nokia 2000S (Asia/Pacific). Released Oct. 1998; equipped with CAM/PCMCIA slot, capable of Irdeto, others (factory will NOT supply CAMs at this time); no Asia-Pacific sources known at this time (but readily available through European sources); review 11/98.
Nokia 9200/9500/9600/9800. FTA, factory software does PowVu poorly, but has significant Internet software support. Ultimate play-around hobby machine but not consumer friendly. Original V1.63 had unique ability to search entire satellite to locate and list all SCPC/MCPC services; latest (V5.X software) versions compatible with Dr. Overflow (V7.X) software from Internet. CI (common interface) versions available in Europe, do not presently allow Irdeto however. No Pacific/Asia support; help from Av-Comm (61-2-9949-7417), and software from www.BAKKERELECTRONICS.COM.
PACE DVS-211. NDS CA only (no FTA); Sky Racing (As2), Indovision, others. (Sky Racing - Bob Pankhurst 61-2-9451-0888)
PACE DGT400. Original Galaxy (now Foxtel Sat/Austar) IRD, Irdeto, FTA with difficulty. (Foxtel Australia 1300-360818).
PACE DVR500. Original NBC affiliate IRD; FTA or Irdeto (w/CAM). Similar to DGT400, more reliable. No sources.
PACE "World Box." (DSR-620) Created for NDS non-DVB compliant MPEG-2, including Sky NZ. Info, ++49-211-526-9833.
Panasat 520/630/635. MCPC FTA, Irdeto capable. **Out of production**; spares from UEC (fax ++27-31-593-370, Russell Futter).
Panasonic TU-DS10. FTA, Irdeto CA. (see SF Aug. 1998). Aurora, Optus DTH. (Antares 61-7-3205-7574; Evcom 61-2-9316-5055).
Phoenix 222. FTA, PowVu. Exceptional graphics, ease of use. (SATECH 61-3-9553-3399)
Phoenix 333. FTA MPEG-2, analogue, positioner. Available late November; review this issue. (SATECH 61-3-9553-3399).
PowerCom. FTA, PowVu, exc. sensitivity. (NetSat 61-2-9687-9903)
PowVu /PowVu D9223, 9225, 9234). Non DVB compliant proprietary format capable MPEG-2 FTA with optional software. 9234 sold for GWN and NHK Joho PAS-2, EMTV As2, CA access; others for various CA services. (Scientific Atlanta 61-2-9452-3388)
Praxis DigiMaster 9600 MKII/9800AD. FTA, PowVu + analogue.; (Skyvision Australia 61-2-6292-5850; Telsat 64-6-356-2749)
Praxis 9800 ADP. FTA, PowVu, analogue, positioner. (Skyvision Australia 61-2-6292-5850)
Prosat 2102S. FTA, NTSC + PAL, SCART + RCA. (Sciteq 61-8-9306-3737)
SatCruiser DSR-101. FTA, PowVu, NTSC + PAL. (Skyvision Australia 61-2-6292-5850; Telsat 64-6-356-2749)
SK888. (aka DigiSkon from Sun Moon Star). FTA MCPC, Irdeto CAM capable. (Skandia 61-3-9819-2466)
UEC 642. FTA, Irdeto built-in, for Aurora + Optus DTH. (645 rack mount industrial version) (Nationwide 61-7-3252-2947)
UEC 660. Designed to Optus specs, includes twin-card reader (1 smart, 1 credit) for Optus DTH. (Nationwide 61-7-3252-2947)
YURI HSS-100C. FTA, rebadged Hyundai V.2.27 software custom to Australia (Nationwide 61-7-3252-2947)
IRD Play toys:
MK12 smart card reader, writer. Software not readily available, not recommended. (V.K. Radio Services vkradio@tbsa.com.au)
Piracy status updates: . www.maxking.demon.co.uk, www.multipage.net/multi/cards/html; www.wedzboyz.demon.co.uk

SatFACTS Pacific/Asian FTA ANALOGUE Watch: 15 Dec. 1998

Copyright 1998: SatFACTS, PO Box 330, Mangonui, Far North, New Zealand (FAX 64-9-406-1083)

BIRD / Location	RF/IF & Polarity	Service	Errata
2DT/55E	3820/1330L	DD1	
1703/57E	3755/1395R	Sun Music	
	3798/1352R	RTNC	
	3980/1170R	AsiaNet	
	4055/1095R	WorldNet	VOA subcar.
	4125/1025R	TVi	
	4175/975L	Muslim	
1704/66E	3765/1385R	Tests	
	4015/1135L	Mongolia	(Secam)
PAS4/68.5E	3743/1407V	RTPi	
	3840/1310V	Home Ch.	(may be off)
	3785/1365H	CNBC	
	3864/1286V	BBC World	
	3910/1240H	Sony TV	Hindi
	3907/1243V	Maharishi	
	4034/1116V	Doordan	
	4085/1065H	CNNI	
	4110/1040H	TNT/Cartoon	
	4113/1037V	Series Ch.	
	4185/965H	MTV	
PAS7/68.5E	3470/1680V	Test Signal	
Ap2R/76E	3760/1390H	AXN card	
Thaic3/78.E	3871/1279H	TVT	
	3760/1390V	Army TV	
	3690/1460V	MRTV	
	3685/1465H	Mynamar	
	3635/1515V	RAJ-TV	Tamil
	3576/1574V	ATN Bangla	Bengali
	3536/1614V	Punjabi TV	Punjabi
	3476/1674H	ATN	
Exp. 6/80E	3672/1478L	TK Rossija	(north only)
	3875/1275L	VTV4+	(north only)
	3925/1225L	ACT/TB3	(north only)
	4125/1025L	Russia 3	(north only)
	4025/1125L	Prometei AST	(north only)
ChiStr1/87.5	3550/1500V	Tests	NTSC reptd
CIS S6/90E	3675/1475R	RTR1	
	3875/1275R	Orbita 1	
	3916/1234R	RTR II	
	3935/1215R	Orbita II	
MeSat1/91.5	3710/1440H	VTV 1,2,4	

MeSat-1/91.5E	3710/1440H	VTV 1,2, 4	
	3880/1270H	RTM-1	
Insat2B/93.5E	4163/987H	India Metro	Aust on 3.7m
	4128/1022V	Ind. National	Aust on 3.7m
	4070/1080H	India DD9	
	4080/1070V	DD7 (Tamil)	
	3970/1180V	DD9 (kan.)	
	3882/1268V	India DD1	
	3840/1310V	India DD	
	3762/1388V	India DD4	
CIS-S20/96.5E	3675/1475R	ORT	
	3825/1325R	Madagascar +	
	3875/1275R	Test Card	
AsSat2/100.5E	3642/1508H	ERTU Egypt	
	3660/1490V	Test Card	
	3680/1470H	Feeds/Iran	
	3860/1290V	Feeds #	
	3885/1265H	WorldNet	VOA Subcar.
	3960/1190H	CCTV4	
	3980/1170V	RTPi	Radio Subcar.
CIS S21/103E	3675/1475R	RTR	
	3875/1275R	Vrk.Apt	
PalB2R/108E	4000/1150H	TVRI	
PalC2/113E	4183/967V	TPI/TVRI	
	4160/990H	(France) TV5	
	4140/1010V	Brunei, feeds	
	4120/1030H	MTV Asia	
	4080/1070H	Herbalife	2100HK/NTSC M/Tu/Wd
	4060/1090V	TV Indosiar	
	4040/1110H	CNBC	
	4020/1130V	ANteve	(left air?)
	3970/1180V	CNNI	(was 3980)
	3960/190H	SCTV	(reported off)
	3900/1250V	Malaysia TV3	
	3880/1270H	Aust. ATN7	
	3765/1385H	NBC, CNBC	Feeds, Herbalif
	4042/1408V	RCTI	English subcar
AsSat-G/122E	3675/1475L	Moscow 6	Very powerful
JcSat3/128E	4080/1070V	Test Card	Covers S. Pac.
	3980/1170H	Test Card	
Ap1A/134E	3820/1330H	CETV SD	

December Alert

All eyes are on 166E for signs of PAS-8 non-test levels. Intermittent testing reported to date has not included Ku; this is the important one for FOXTEL satellite.. ST1 at 88E is now "officially" functioning. CNBC (Pas-2) adds "Executive Sports" weekends; primarily Golf.

UPCOMING SATELLITE LAUNCHES

JcSat 6 to 154E - delayed to January 14(Ku)
 ChinaSat 8 - Jan ('99) to 115.5E, Ku + C
 InSat 2E to 83E - Delayed to "early '99"
 Gorizont 33 - to unknown location January
 AsiaSat 3S to 105.5E - March 1 (C + Ku)
 Orion 3 to 139E - delayed to March 8 (C+Ku)
 Intelsat K to 95E - March 12 (HP Ku)

53.2	55	57	66	68.8	76	78.5	80	87.5	88	93.5	93.5	96.5	100.4	103	105.5	107.1	108	110.5	113	120
S27	2DT	1703	1704	PAS4 PAS7	Ap2	Th3	Ex2	Cs1	St1	Me-1	In2B	S20	As2	S21	As1 (As3)	Ct1	B2R	Ss1	C2	Th1/ 2
C	C	C	C	C	C	C	C	C,Ku	C	C,Ku	C	C	C,Ku	C	C	"S"	C	C,Ku	C,Ku	C

122	128	134	138	(139)	140	145	146	148	151	152	156	160	161?	166	169	174	177	180	177	148
As-G	Jc3	Ap1a	Ap1	Or3	S7	S16	Ag2	Me2	C1	A3	B3	B1	Mb1	PAS8	PAS2	1801	1702	1701	IF3	Es4
C	C,Ku	C	C	C,Ku	C	C	C,Ku	C,Ku	C	Ku	Ku	Ku	C	C,Ku	C,Ku	C	C,Ku	C	C,Ku	Ku

Ap1A/134E	3900/1250V	CETV2	
	3980/1170V	CETV1	
Ap1/138E	4160/990H	CCTV7	
S7/140E	3675/1475R	Test Card	mod. inclined
S16/145E	3675/1475R	Test Card	high inclined
	3875/1275R	Feeds, tests	high inclined
Ag2/146E	3787/1363H	GMA	poor s. eqtor
Me2/148E	4080/1070H	test card	occ. use
C1/150E	4160/990H	RCTI	tests/entire sat inactive?
PAS2/169E	4000/1150V	CNNI	1/2 Tr format
	3780/1370V	Feeds-Napa	
1802/174E	4166/984R	Feeds	
	4177/973R	Feeds	
1702/177E	4166/984R	Feeds	/KBS Korea
	4187/963R	Feeds	Feeds
1701/180E	3810/1340R	Feeds	
	3841/1309L	RFO	East beam
	3845/1305R	Feeds	inc. USA
	3930/1220R	Feeds	Typ. encrypt.
	3975/1175R	Feeds	
	4060/1090L	Feeds	
	4130/1020L	Feeds	
1513/177W	4187/963R	Feeds	occ. use
	4166/984R	Feeds	occ. use

Oddball Formats

PAS-4/68.8	3785/1365V	Discov. India	rptd. BMAC
PAS-4/68.8	3860/1290H	ESPN Indian	rptd. BMAC
Ap2/76E	3960/1190H	HBO Asia	GI Digiciph2
C2/113E	3930/1220H	Fil. Peo. Net	GI 1.5 MPEG
PAS2/169E	3836/1314H	ABS/CBN	GI 1.5 MPEG
PAS2/169E	3989/1161V	Fox/Prime	Sal.5MPEG

YOUR OBLIGATION: If you read and use these charts, your part is to notify SatFACTS when we get it wrong. We depend upon the input from thousands of reader/users to get it right. DO YOUR PART - let us know when we have an incorrect or incomplete listing here.

Optus B3 at 156E / Ku only

12.688/1388H	Austar MPEG	Irdeto CA IRD	list, p. 18 Sept
12.658/1358V	ABC WA	BMAC RABS	until 03/99
12.626/1326H	Austar MPEG	Irdeto CA IRD	list, p. 18 Sept
12.595/1295V	Aurora MPEG	Irdeto CA IRD	RABS, card req.
12.533/1233V	Net 9, Sky	typ. B-MAC	interchange
12.530/1230V	Herbalife	10-1000UTC	NZ beam
12.470/1170V	(School TV)	analogue	limited hours
12.438/1138H	Austar MPEG	Irdeto CA IRD	list, p. 18 Sept
12.407/1107V	Aurora MPEG	Irdeto CA IRD	RABS, card req.
12.340/1040H	Imparja	BMAC RABS	until 06/99?

Optus B1 at 160E / Ku only

12.730/1430H	RHEF, NZ feeds	typ FTA anal.	occ. use
12.677/1377H	QSTV	BMAC RABS	until 06/99?
12.670/1379V	SE ABC	BMAC RABS	until 06/99?
12.644/1344V	SE ABC	BMAC RABS	until 06/99?
12.639/1339H	NE SBS	BMAC RABS	until 06/99?
12.613/1313H	NE ABC	BMAC RABS	until 06/99?
12.596/1296V	Sky Racing	BMAC	
12.576/1276H	ABC Radio	digital	
12.570/1270V	OmniCast		FM/FM
12.547/1247H	ABC feeds	typ. analogue	occ use
12.545/1245V	Sky NZ Sport	Vidicrypt	temp to 01/99?
12.520/1220H	Net 9 feeds	typ. BMAC	
12.518/1218V	Sky NZ "1"	Vidicrypt	temp to 01/99?
12.482/1182V	Net 10 feeds	typ. E-PAL	
12.480/1180H	Net 9 feeds	typ E-PAL	
12.455/1155V	Net 10 feeds	typ. analogue	
12.455/1145V	QTQ9		
12.448/1148H	Herbalife	10-12UTC	now off? see B3
12.418/1118V	Trackside NZ	FTA analogue	NZ beam; temp
12.391/1091V	Sky NZ test	NDS MPEG	Pace DSR-620
12.376/1076H	Aurora tests	MPEG-2	CA, inactive?

Using these charts: Microwave signals transmitted down to earth by satellite are intercepted by a parabolic reflector, redirected to a smaller "feed" antenna where they are frequency shifted (down converted) to a lower intermediate frequency (IF) for carriage to the actual receiver (IRD). Some receivers display downlink frequencies at their original microwave (i.e., 3720) while others display the receiver IF (i.e., 1430). Our charts list both for ease of use. C-band IFs are calculated by taking 5150 (local oscillator or LOF) and subtracting the C-band microwave frequency (i.e., 5150 - 3720 = 1430). Ku band IFs are found by taking microwave frequency and subtracting 11,300 (LOF); i.e., 12,655 - 11,300 = 1,355. LOF is marked on most LNBS; typically 5,150 for C-band, 11,300 for Ku (note: check Local oscillator frequency - LOF - on unfamiliar Ku LNB/LNBF products; may not be 11,300!). **DIGITAL WATCH LISTINGS** - when "service" is known to be FTA, it is **bold face**. When bouquet is partially FTA, right hand column will have **bold face** notation.

WITH THE OBSERVERS

AT PRESS DEADLINE

PanAmSat testing sequence reportedly was complete on December 7th and first "routine" transmissions were to begin "anytime after December 8th."

PAS-8 Testing

PanAmSat's newest satellite has now been in the air and "on station" for more than a month. The reports are few and far between, indicating testing activity has been confined to relatively brief periods (certainly there is an "army" of observers looking for signals!).

C-band reports are at best text book in content if you choose to believe the satellite's footprints will - in fact - be nearly identical to those first published in SF in our #45 (May 1998) issue (p. 14 and 15). Those official maps showed Ku band coverage peaking in Australia at 49.5 dBw over Sydney and Melbourne (75cm dish for 3 dB margin) and C-band at 39 dBw peaking over Indonesia and SE Asia (1.4m dish for 3 dB margin). For Australia on C-band, 38 dBw at Darwin reducing to 33 dBw at Sydney and Brisbane and 31 dBw at Perth, Melbourne.

The reality is that PanAmSat (the satellite operator) does not plan "on ground testing" for PAS-8 until mid-December; these tests will occupy the better part of 4 weeks because of the consecutive holiday periods. Until the testing is completed, there will be no formal announcements regarding the real world coverage (which usually differs somewhat from the pre-launch footprint maps releases - remember the Palapa C2 episode!). Coop's Technology Digest for December 4th reported CNNI, EWTN, TNT/Cartoons, and Discovery are on the "move-from PAS-2 to PAS-8" list. PanAmSat has released no lists itself but various programmers have disclosed their status. One programmer advised CTD that, "if we are required (by PanAmSat) to move to PAS-8, we have been told we will lose no existing viewers." There are two possible ways "not to lose viewers" in this situation:

1) The coverage of PAS-8 so closely mimics PAS-2 that for all practical purposes they are identical. This is contrary to the PanAmSat published footprint maps of last May, but PanAmSat has told at least one programmer now on PAS-2, "We have made a last minute adjustment to the coverage pattern of PAS-8 which will benefit New Zealand."

Or,

2) Somebody agrees to fund (as in pay for) new (larger) dishes for those locations now taking service from PAS-2 but unable (with their existing size antennas) to get reception from PAS-8. One programmer told CTD, "There is a discussion ongoing whereby PanAmSat would pay for new dishes for our

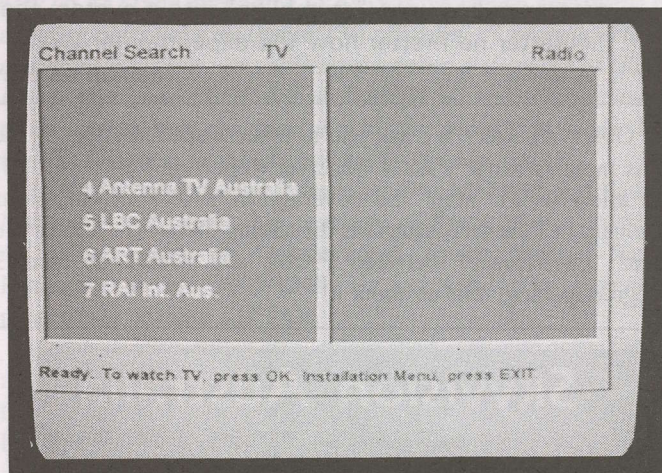

The loading of the "Eastern-Med" bouquet. Now that the ART/RAI bouquet (4151/999Hz) is terminated, this is the one.



Greek Antenne 1 is new - although ERT feeds are found most days around 0630 UTC on 3765/1385R of I180 (see p. 18).

customers who cannot receive us if we move to PAS-8. "All of this "smoke" should be clear by mid-February; in the meantime, users of PAS-2 and potential users of PAS-8 are caught in a twilight zone of uncertainty.

WITH THE OBSERVERS: Reports of new programmers, changes in established programming sources are encouraged from readers throughout the Pacific and Asian regions. Information shared here is an important tool in our ever expanding satellite TV universe. Photos of yourself, your equipment or off-air photos taken from your TV screen are welcomed. TV screen photos: If PAL or SECAM, set camera to f3.5-f5 at 1/15th second with ASA 100 film; for NTSC, change shutter speed to 1/30th. Use no flash, set camera on tripod or hold steady. Alternately submit any VHS speed, format reception directly to SatFACTS and we will photograph for you. Deadline for January 15th issue: January 3 by mail (use form appearing page 34), or 5PM NZST January 4th if by fax to 64-9-406-1083.

-UPDATE: The Status of Australian Irdeto Piracy-

Although Optus Vision cards have not yet been put into circulation (reportedly, 25 channels load when you have an appropriate card), at least one of the "Beta Test Cards" has fallen into the hands of a software programmer. Results? Not from us, here. Mark 12 users (there are reportedly, "nearly 50 of the programmer devices now in Australia") have found the "read" software available from various web site addresses is useful in *reading* Austar/Foxtel cards but the "write" software is far more difficult to properly source and administer. Bottom line? Although the "pirates" in Europe appear to have been successful in cracking Irdeto technology, SatFACTS cannot report it has been done in Australia. Flat statement? Not quite. There is a vast difference between "stumbling" into a system that clones *one* card - one time (and never, successfully thereafter no matter how the experimenter works at it), and, being able to turn them out in a repetitive fashion as they do in Europe.

Observers note: We ask you to make a special effort to use this month's extra "PAS-8 Observer Reporting Form" (p. 34) to allow us to "map" the coverage of PAS-8 in either our January or February issues (as the testing dictates). And if you find "interference" between PAS-2 and PAS-8 at their 3 degree spacing, tells us about it!

Observers reporting various forms of PAS-8 testing include **David Leach** (NSW - 3900-3920 Hz), **Smythe** (3960/4000/4040/4080 all Vt), **Colquhoun** and others.

Observer **Robert Skilton** (Te Anau, NZ) reports the Thai TV5 bouquet on I2.650Hz I702 (177E) appears to have gone down in level at his location; a 2.4m Andrew with 0.6 dB LNB now locks but with very little margin.

Apstar 2R. Remember the ill-fated Taiwan line-up on 177E that included some triple-X USA material? Well, less the triple X, the package is back again. 3695/1455 Vt with Msym 21.088 and FEC 5/6. Included - a movie service in English with Chinese subtitles, 9 FTA (for now) (**Leon Senior**, Melbourne on a 2.4m). In Asia proper - Ku MCPC services reported on 12.365 Hz and 12.278, .303 and .401 Vt, 12.365Hz.

AsiaSat 2. Reports of non-identified testing with test card on 3860/1290Vt. This channel has occasional feeds on it as well. APTV/APTN news feeds: If they have been lost, try reloading (new PIDs).

Cakrawarta S-band. Add two new carriers (2543/1107 and 2530/1120) making total of six now. SCTV has been running FTA from time to time on various transponders (**Steffen Holzt**, New Caledonia, **Roger Woodward**, Sydney).

Express 6 at 80E. Russian reports say testing of 4 programme channel MPEG-2 digital scheduled to begin on 4025/1125 (LHC). This is probably a north only beam so good luck unless you are reading this in Asia proper.

Gorizont at 96.5E is "officially" replaced; #20 has replaced #27 explaining November's report of improved signal levels. The NTV service on 3675/1475 is the early release (+8 hour) version for extreme Eastern Russia.

Palapa B2R (108E and not frequently reported - coverage is very poor) has Anteve in FTA MPEG at 3754/1396 Vt (Msym 6.000, FEC 3/4). David Leach (NSW) believes this satellite is inclined (a replacement is scheduled for mid 1999).

Palapa C1 at 150.5E - the "forgotten" (and expensive) bird. Reports of video test card (text: "Satelindo Palapa C1") on 4160/990Hz. A Jakarta report at presstime says, "A battery

ARBN: F00094467
Skyvision Australia

Factory direct Importers and Distributors

Sole Australian Importer of Hyundai Digital receivers

HSS-100C Digital MPEG 2 IRD version 3.11 (Nokia tuner)
HSS-200R Commercial MPEG 2 IRD -19 inch rack mount
HSS-680A Digital/Analog MPEG 2 IRD - soon to be released

We also supply the following quality products

Satcruiser DSR-101 NTSC/PAL MPEG 2 IRD
Praxis Digimaster 9600 MKII Digital/Analog IRD
Praxis 9800ADP Digital/Analog IRD with positioner
Nextwave and Palcom Analog/Positioner Receivers
KTI satellite dishes from 2.3 - 3.7 metres
Huge range of feedhorns and LNB/LNBFS
Superjack actuators from 12 to 36 inches
Positioners, Field Strength meters, Ku band dishes

1998 Product catalogue with prices, available now

Retail, Trade and Export enquiries welcome

Tel: +61 2 62925850 Fax: +61 2 62925890
Web Site: <http://www.bigfoot.com/~skyvision>
E-mail: skyvision@bigfoot.com

small, medium and LARGE C and Ku antennas in stock!

Transmit and receive antennas from 1.2m to 13m (Intelsat Standard B). Linear and circular feeds (AsiaSat, Palapa, JcSat, Rimsat, PanAmSat, Intelsat and more) for transmit and receive-only applications. Receive and transmit electronics including inclined orbit tracking equipment with motor drives for elevation and azimuth to 50 tons. Complete system design, fabrication, installation + proof of performance.

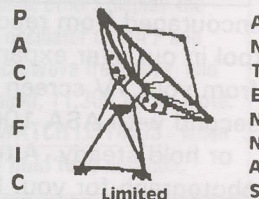

anomaly has been detected on C1 and all C1 traffic will be moved to C2." Is this the end of C1???

Palapa C2. Gujarat TV at 3800 Hz appears to have shut down; MPEG signal has been seen (but not identified) at 3795/1355. Anyone have more information? RCTI has been seen FTA testing on 3455/1695 Hz (Msym 8.000, FEC 3/4) (Fahey, NSW). Other unidentified MPEG test signals at 4005/1145 Hz and 3795Hz (note new NBC, CNBC analogue feeds on 3765 Hz). Indovision tests on Ku 11.645 Vt are gone; Maharishi is on 11.650 Vt in NTSC, FTA. Observer **Ernie Wright** reports 3760/1390Hz feeds for NBC are now time shifted with Late Night appearing at 8PM AEST. This appears to be a feed from Los Angeles channel 4 NBC outlet.

PAS-2 C-band. Observer David Leach (NSW) reports sports feeds FTA analogue "mornings and evenings " (AEST) on 4030/1120 Vt. CNNI backhaul feeds from Asia (Hong Kong) to USA on 3996/1154Hz with Msym 9.998 and FEC 3/4 (Robin Colquhoun). TVBI is new in old ABN slot on 4148/1002 Vt (HK uplink). ART/RAI 2 channel service on 4153/997 Hz has ceased; occasional feeds there now. New ART/RAI/LBC/Antenne service on 3778/1372 Vt ((Msym 13.300 and FEC 3/4) reported "60% of 222 bar graph meter on 3m dish" (Laurie Mathews, NZ).

PAS-2 Ku. Maharishi Open University now on 12.664.5/1363.5 Vt with Msym 3.300 and FEC 3/4 (David Hudson, NZ).

ST-1 at 88E. Testing underway with colour bars at 3550/1600 Vt and (Chinese) programming.

Thaicom 3 has occasional FTA feeds on 3520/1630 Hz (Msym 26.600, FEC 3/4). On Asian beam, ATV Bangladesh on 3554/1596 Vt FTA PAL (0300-0600 and 1200-1800 UTC).

GWN guides for PAS-2 Ku. Available from http://www.gwn.com.au/guides/guide_WA_sat.html.

Sagem ISD 3400 is latest French built IRD. FTA and internal (not CAM) common interface (CI) for Viaccess. Nagravision (ands possibly others). Not built for SCPC - Msym 15.000 - 30.000 with 2 Mbytes of RAM and Flash.

IRD shortage - not just in New Zealand (with new Pace DSR620; see CTD for December 4). The Star Asia service now on As2 (and expanding to As3S if the launch goes well) is advising potential new (cable TV) affiliates, "Unfortunately at this point in time we are still experiencing a shortage of IRDs. I hope you understand that we have to allocate the receivers to the system that provides us with the greatest revenue. We hope to have this problem resolved by the new year."

PAS-2 C-band special. Observers **Stu McLeod** and Laurie Mathews (NZ) report live coverage of Space Shuttle mission to deliver parts for International Space Station found December 6 on 3901/1249 Hz in California Bouquet: programme channel 2 (FTA).

Optus Vision has a new relaunched web site with faster access times but no real information. Try <http://enterprise.optus.com.au>. Site says DTH pay service will begin "early 1999" for Western Australia, yet another postponement of a service that never quite seems to get itself operating.

Optus Aurora platform - ABC Northern Territory radio and TV operational with Imparja trying to join the club. Next up - South Australia ABC. Optus stands by their "formal" announcement we reported in November (p. 2). "Imparja scheduled to begin December 10, NE (Queensland) zone February 26 and SE (NSW) zone March 12."



MELBOURNE SATELLITES P/L

ACN 065 270 733

Established 1992

Direct importers and suppliers of the following world renown products.

**KTI
ORBITRON
PATRIOT
JONSA
ANDREW**

**ECHOSTAR
SCIENTIFIC ATLANTA
NOKIA
IKUSI
DX**

**GARDINER
CALIFORNIA AMPLIFIER
MTI
CHAPARRAL
ADL**

Full range of cables, splitters and connectors.

Phone, fax or write for our 1998 Product SA7alogue.

Phone: (03) 9738 0888
Fax: (03) 9729 8276

Sales/Warehouse - 84 Bayfield Road, Bayswater Victoria
Construction Services - 13 Elsum Avenue, Bayswater Victoria
Postal Address - PO Box 901, Bayswater 3153 Victoria Australia

SatFACTS December 1998 • page 31

User Friendly Site!

www.melbournesatellites.com.au

e-mail: sales@melbournesatellites.com.au

AT

Sign-off

A birthday is coming up - the first anniversary of telecasting for SPN, the Nauru based 12 hour per day sport programming service. Amongst the significant "firsts" SPN has managed in their brief tenure on the air - live coverage during July-August of the Micronesian Games held in Palau (for summary of this technical challenge, see SF#49 p. 2 letter from Aaron Gosschalk of ATN 7).

SPN uplinks using a 4.6m (Andrew brand) dish and typically 160 watts of SCPC "power." That is not a very big antenna, not very much power. But satellite host Intelsat won't allow them much more since they purchase transponder "space" and receive back "permissible power levels" based upon the bandwidth they occupy. This is not unlike the fTV service reported on p. 6 in this issue.

SPN has developed a respectable relationship with cable system operators from Guam to New Zealand and Australia. And, with terrestrial rebroadcasters spread throughout the Pacific. There are a few "holes" in their coverage - Fiji, for example where viewers have to invest in dishes and satellite gear to access SPN.

SPN depends upon advertising for revenue (they continue their FTA policy) but there has been precious little of that. So a Nauru sporting federation, the group that put money on the table to launch SPN, is continuing its support. Finding alternate sources of revenue for SPN is increasingly at the top of their management priority list. They have several options - while continuing to seek advertising from "internationally recognised brand name" firms. One is to encrypt and charge money to view. Another is to sell, rent, lease out the 12 hours per day they are not presently using themselves (other than with a test card). Since they are already on the air with a signal 24 hours, finding someone to purchase their unused hours seems like a good alternative.

The possible users vary widely from a religious group seeking coverage in the Pacific to an adult movie service (that would encrypt and sell subscriptions). The important point here is simply that SPN has 12 hours of non-use satellite time, on a "global" beam that reaches from the west coast of the USA clear around past western Australia into all of SE Asia. The hard technical part has been accomplished - getting on the air and staying there for nearly a year now.

There is probably a "bargain" here for the right programmer - an opportunity to reach all of the Pacific including Japan and Korea to serve SMATV and CATV dishes as well as terrestrial rebroadcasters. The downside is that while home systems in the 3m dish range can access SPN, a commercial user would require something larger - probably a 4.5m. That unique-to-Intelsat circular polarisation is not a challenge to fixed dish installations (merely select the correct ADL feed) although for home dishes, making a linear feed work properly on circular remains difficult (see some additional reasons to "fix" this problem on p. 18 here). SPN can be reached at ++674-444-3895



Sports Pacific Network (SPN) first signed on the air January 31 (1998) to mark the birthday of host country Nauru.

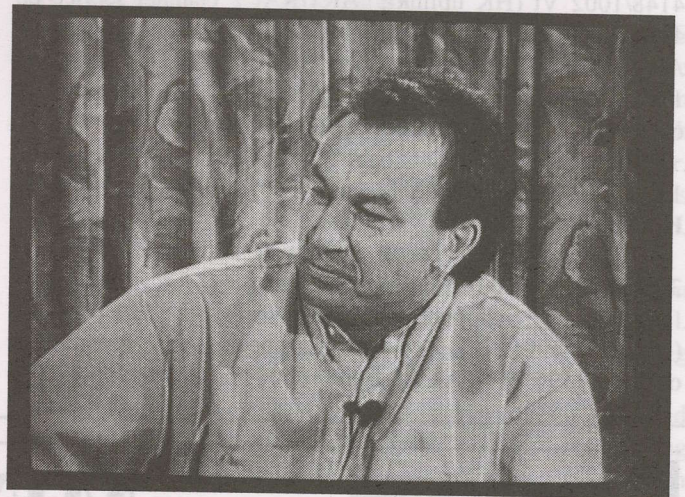

Service "spark plug" Brandon Telfer, an Australian, has become a familiar and respected sport commentator via SPN.

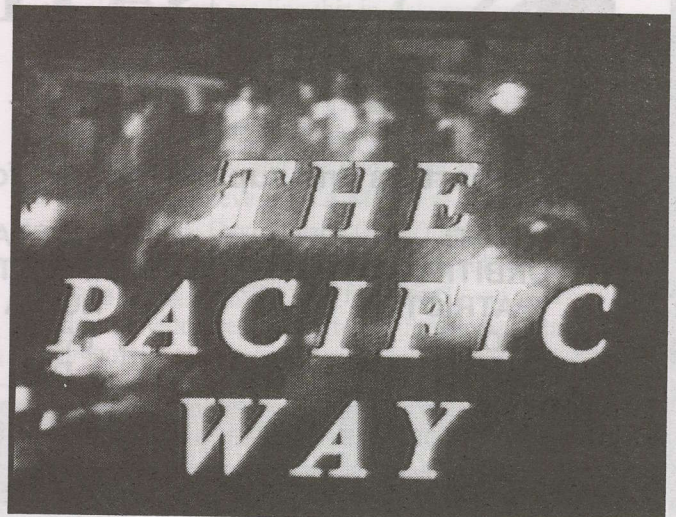

The "way of the Pacific" is proving to be a significant challenge to the commercial success of SPN.

What about SPN "moving" to Orion 3 (139E) and possibly Ku after it is available? SPN has decided this is not what they want to do at this point in time but do not rule out a second Orion Ku band service in the future.

THE 1998/9 SATELLITE EXPLOSION IN THE PACIFIC/ASIA!

One down and four to go over the next 3 months.
InSat 2E ... Gorizont 33 ... ORION 3 ... AsiaSat 3!
Stay tuned with SatFACTS!

- ENTER my 12 MONTH subscription to SatFACTS starting with January 15th issue (rates below)
 ENTER my 36 MONTH subscription to SatFACTS starting with January 15th issue (rates below)

NAME _____
Company (if applicable) _____
Mailing address _____
Town/city _____ Country _____

Amount to send: 1 year - NZ\$60 (inside New Zealand) / A\$90 (inside Australia) / US\$60 (outside of NZ and Australia) or 3 years - NZ\$140 / A\$210 / US\$150 if by cheque. **VISA** or **Mastercard**? See form below and return with order. Return to: **SatFACTS, PO Box 330, Mangonui, Far North, New Zealand** or if by VISA or Mastercard fax to 64-9-406-1083

ALL SatFACTS SUBSCRIPTIONS ARE SENT VIA AIRMAIL - WORLD-WIDE!

USE THIS FORM ONLY WHEN CHARGING ON VISA/MASTERCARD

Please charge my **VISA/Mastercard** as follows:

- ONE Year of SatFACTS MONTHLY (NZ\$60, A\$90, US\$60)
 THREE Years of SatFACTS MONTHLY (NZ\$140, A\$210, US\$150)
 SATELLITE TELEVISION: The Booklet (NZ\$10, A\$12, US\$10)
 One Year of COOP'S TECHNOLOGY DIGEST (NZ\$125, A\$125, US\$125)

Indicate charge card type: VISA Mastercard

Name (as it appears on **VISA / Mastercard**) _____

VISA/Mastercard Number _____ - _____ - _____ - _____

VISA/Mastercard expiration date _____

Instructions: If ordering by mail, return this complete (3-part) card or a copy of same (to **SatFACTS, PO Box 330, Mangonui, Far North, New Zealand**); if order by FAX, send full card as a single sheet to **64-9-406-1083**

SUPPLEMENTAL MATERIALS from SatFACTS MONTHLY: Order Form

- SATELLITE TELEVISION:** The Booklet. Excellent introduction to home dish ownership for the layman, including major contributions from the father of geostationary satellites - famed science fiction writer *Arthur C. Clarke*. The perfect tool to help the satellite system seller explain home satellite TV to the layman consumer. From SPACE Pacific. NZ\$10/ A\$12 / US\$10, airmail.
- COOP'S TECHNOLOGY DIGEST.** For the really serious enthusiast, investor, business person in satellite television and allied leading edge technologies. Ten issues each year, jam-packed with information you will not find anyplace else. "Coop" routinely culls more than 60 publications world-wide, terribly expensive newsletters, Internet and his hundreds of private contacts to keep you right at the leading edge of technology on the **REAL** changes underway in telecommunications. Conveniently issued near the **first of the month**, creating an excellent time-line-filler between the mid-month issues of SatFACTS. Now in the **6th year**, airmail world-wide. Normally NZ/A/US\$250 per year - for SatFACTS subscribers special **50% discounted** price of NZ/A/US\$125.

OBSERVER REPORTING FORM - Due January 5, 1998

• NEW programming sources seen since November 1st: _____

• Changes (signal level, transponder, programming content) in pre-existing programming sources since November 1st: _____

• OTHER (including changes in your receiving system): _____

NOTE: Please use P1 - P5 code when describing signal levels and receiver IF/RF settings.

Your Name _____

Town/City _____

Make/size dish _____ LNB _____ Receiver _____

Your email address _____ if you have one!

MAIL TO: SatFACTS Monthly, PO Box 330, Mangonui, Far North, NZ or fax 64-9-406-1083

SPECIAL PAS-8 OBSERVER REPORTING FORM - Return WITH top portion!

Please note receiver frequencies (in C or Ku band, or L-band IF as your receiver indicates) for each signal reported. In summary, tell us how the various signals observed compare with BEST CASE reception through PAS-2 at your location.

PAS-8 C-band: Please list test signals or modulated signals observed by frequency.

/Vertical polarity - _____

Strongest seen on vertical? _____ Compares with PAS 2 as _____

/Horizontal polarity _____

Strongest seen on horizontal? _____ Compares with PAS 2 as _____

PAS-8 Ku-band: Please list test signals or modulated signals observed by frequency.

/Vertical polarity _____

Strongest seen on vertical? _____ Compare with PAS 2 as _____

/Horizontal polarity _____

Strongest seen on horizontal? _____ Compares with PAS 2 as _____

Comments - _____

SOUTH PACIFIC REGION Satellite & Cable Show '99

- YES - Send SPRSCS '99 Registration data
- YES - Send SPACE membership data
- YES - Send SPACE/Mark Long Certification courses data

NAME _____

Company (if applicable) _____

Mailing address _____

Town/city _____



SPACE Pacific Ltd.

PO Box 30, Mangonui, Far North
New Zealand

Fax 64-9-406-1083

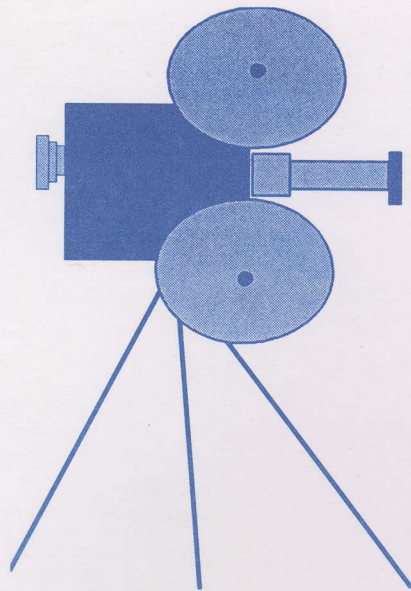

SHOWTIME 99

SOUTH PACIFIC REGION SATELLITE & CABLE SHOW (SPRSCS) '99

2nd CHANCE TO SIGN UP / ATTEND!

March 23 and 24: Mark Long's *SPACE Pacific Digital Satellite TV Course*
If your work requires that you understand digital satellite TV, THIS is the course for you! Two days of intensive schooling, extensive course materials, one-on-one with Mark Long.

SPRSCS
'99

March 25 and 26: *SPACE's Satellite and Cable TV Production Time!*
SPACE Pacific has secured satellite TV transmission time to educate and inform our industry members of the changes taking place in our high-tech world. Help us produce TV programme segments in 2 intensive tape to satellite production days!

March 26 and 27: Mark Long's *SPACE Pacific Satellite Technician Course*
The advanced course for technically inclined students who are after a broad understanding of all aspects of satellite technology (including, of course, digital). Two days, extensive course materials and one-on-one by Mark Long.

March
23 - 27

**IF YOU HAVE NOT BEEN TAUGHT BY MARK LONG -
YOU HAVE NOT BEEN TAUGHT!**

FULL
show
details ...

... are available in brochure form. The dates are March 23-24 and 26-27 for the twin Mark Long/SPACE tutored courses. And March 25-26 for the trade show. Complete brochure request card on page 34 or contact us at (tel) 64-9-406-0651 or (fax) 64-9-406-1083.

中央电视台
CCTV

CCTV
INTERNATIONAL
中国中央电视台
E-mail: tv315@mail.cctv.com

Bloomberg
40 PM
09:25 29.45
16 C
Australia 5 23.1



6:10 15:15
Asia Business Singapore: Insure GE Life, Swiss 20%
Lower Sales in 1998 and Economic Slump
Y84 8825416238 8:35 7:0
307(C) 8825416238 8:60 each



COUNTRY MUSIC TELEVISION

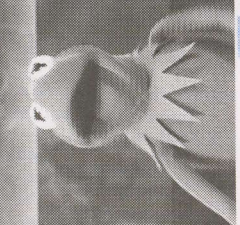

A Service of NBC and Dow Jones

Trade suppliers of quality equipment:



PTY LTD

ACN 009 235 090

Ph: +61 8 9306 3738

Fax: +61 8 9306 3737

sales@sciteq.com.au <http://www.sciteq.com.au>

