

Bob Cooper's

JUNE 15 1998

SatFACTS

MONTHLY



Reporting on "The World" of satellite television in the Pacific and Asia

IN THIS ISSUE

Painful DEATH for Australis/Galaxy

First "Single Chipper" and Analogue/Digital Hybrids are here

GMA Leaves C2, Live World Cup 98, RTIF Voucher Snafu

- ✓ Latest Programmer News
- ✓ Latest Hardware News
- ✓ Latest SPACE Pacific Reports
- Cable TV Connection

Vol. 4 ♦ No. 46

Price Per Copy:
NZ\$9/A\$10/US\$7

"I've been playing. How do I get back to Austar?"

"You'll have to ring one of the bods at Austar and say your short-sighted cat accidentally (but nonetheless miraculously) changed the frequency of your set-top decoder when it attacked the remote mistaking it for a large mouse!"

"Why can't Austar serve me? They gave me a 1800 Foxtel number to call and I registered for satellite TV 'possibly available in ACT by the end of the year.' It all sounds a bit dubious."

"I was Galaxy's first subscriber in Canberra and had it for 3 years and 2 months. I am pissed off with the Government and Alan Fels."

"Had the Foxtel merger with Galaxy gone ahead, it would have been an anti-competitive merger and it would have had serious effects on competition in the industry and, in particular, the likely withdrawal of Optus from local telephony and pay TV. To a degree there was a choice of evils."
(ACCC Chairman Alan Fels)

"After reading about Austar signing programming deals with both Foxtel and Optus, I phoned Austar this morning. I wanted to ask if they would get more Foxtel channels than the ones they previously had from Galaxy. I was thinking of channels like UKTV and Fox 8. If they get channels like that as well as the previous Galaxy channels as well as some of the Optus Vision channels, they would have a better package than anyone else."

"When the lady answered the phone I was asked if I was a Galaxy customer and I said yes. She asked me for my postcode which I gave her and she then said, 'Sorry, I can't talk to you. You will have to phone Optus or Foxtel.' I said I already have Foxtel but that I also had Galaxy as I found the satellite digital picture quality to be so much better than cable. She repeated, 'I can't talk to you. Good-bye' and she hung up."

"If Fels would magically disappear, I feel sure Optus would pick up the Galaxy subscribers."

"One point of interest to people asking if they can keep the receivers and dishes until a refund is forthcoming. The answer is an outright no. Goods belonging to another cannot be used as security for any outstanding debt unless such goods are secured by law (through a bill of sale or mortgage)."

"Most disconnects DO take the dishes. I know people who were disconnected in April and the dish was taken away, leaving cable wrapped around the pole hanging out of the roof."

"The administrator will be obliged to return the premises to its original condition. That would include fixing holes in the roof as well as in the gyprock siding. 'Original' would also include reconnecting or rewiring the home for their TV aerial."

Paracclipse[®]

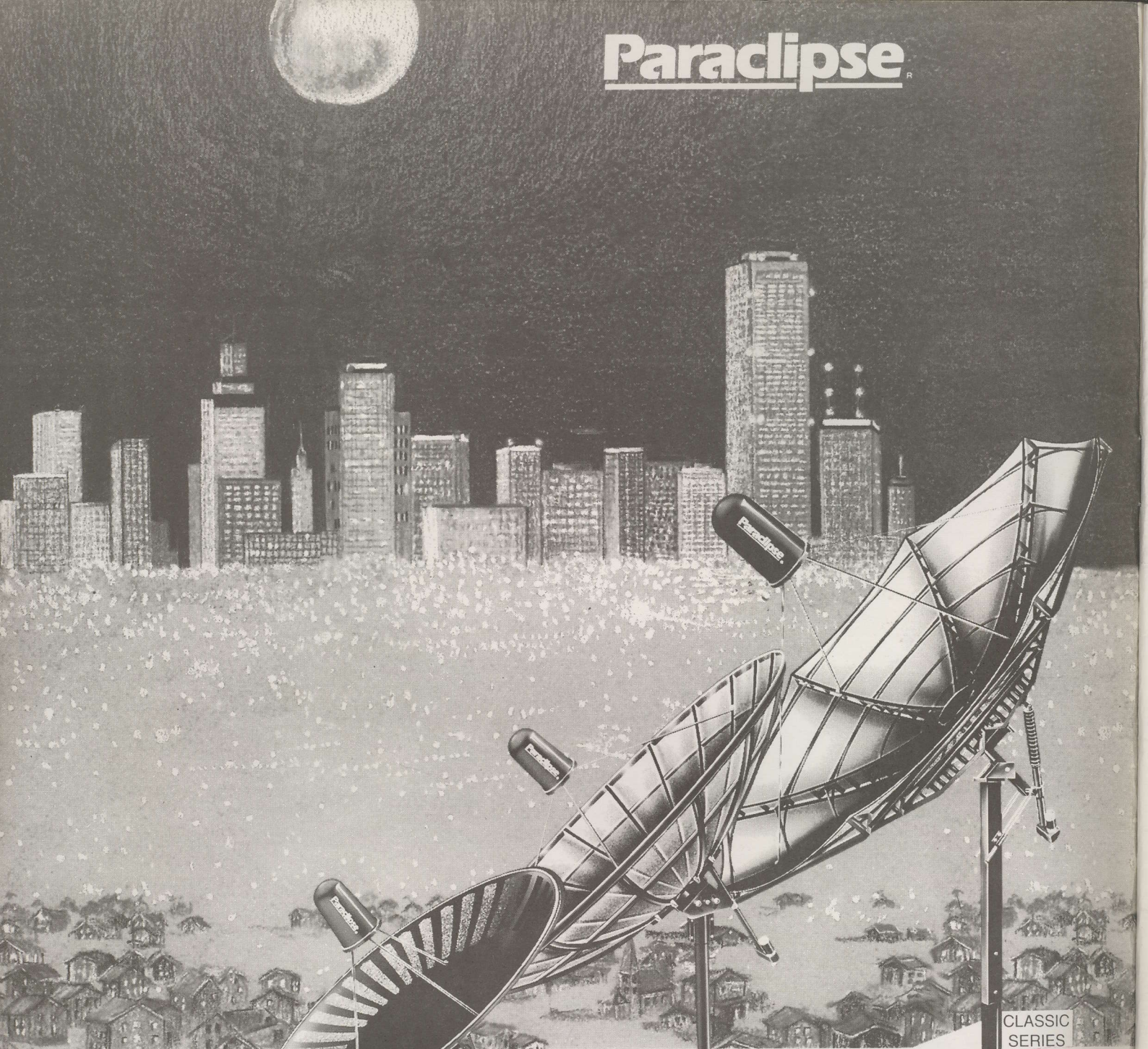

CLASSIC
SERIES

ECLIPSE
SERIES

HYDRO
SERIES

When quality, strength, and accuracy are your main requirements, **Paracclipse** antennas are your first choice.

Only **Paracclipse** offers such variety; four distinctly different series: the Truss-Ribbed Classic, the Courier Deliverable Eclipse, the Stretch Formed Hydro, the Commercial Patriot.

Every **Paracclipse** model sets the industry standard in its class, worldwide.

★ **MADE IN AMERICA**

Distributed in Australia by

SKANDIA ELECTRONICS Pty Ltd.

183 Burwood Rd, Hawthorn, Melbourne
tel 61-3-9819-2466 · fax 61-3-9819-4281

Level 1, 39 Terry St, Rozelle, Sydney
tel 61-2-9555-2955 · fax 61-2-9555-2455

**SATECH Satellite Communication
Technology P.T.Y. L.T.D.**

6/477 Warrigal Rd, Moorabbin East, Vic.
tel 61-3-9553-3399 · fax 61-3-9553-3393

Distributed in New Zealand by

Bay Satellite TV Ltd.

PO Box 3311, Napier
tel 64-6-843-5296 · fax 64-6-843-6429

Paracclipse[®]

HIGH PERFORMANCE ANTENNAS

Paracclipse Inc.

2271 29th Avenue East, Columbus, Nebraska USA 68601
Telephone: (402) 563-3625 Fax: (402) 564-2109

SatFACTS MONTHLY

ISSN 1174-0779

is published 12 times each year (on or about the 15th of each month) by Far North Cablevision, Ltd.

This publication is dedicated to the premise that as we enter the 21st century, ancient 20th century notions concerning borders and boundaries no longer define a person's horizon. In the air, all around you, are microwave signals carrying messages of entertainment, information and education.

These messages are available to anyone willing to install the appropriate receiving equipment and, where applicable, pay a monthly or annual fee to receive the content of these messages in the privacy of their own home. Welcome to the 21st century - a world without borders, a world without boundaries.

Editor/Publisher
Robert B. Cooper (ZL4AAA)
Office Manager
Gay V. Cooper (ZL1GG)

Reaching SatFACTS

Tel: 64-9-406-0651
Fax: 64-9-406-1083
Mail: PO Box 330
Mangonui, Far North
New Zealand

Subscription Rates

Within NZ: \$60 p/y
Australia: AV-COMM Pty Ltd, PO Box
225, Balgowlah, NSW 2093
61-2-9949-7417
Elsewhere: US\$60 p/y
All copies sent via airmail fast post
world-wide

ERRATA

SatFACTS Copyright 1998 by Robert B. Cooper; any form of copying is a violation of our international copyrights. Advertising rate sheet available upon request.

COOP'S COMMENT

One of the tarnished trails laid down by Optus in their battle to stay alive in the RABS and pay-TV games involves the RTIF (Commonwealth subsidy) vouchers. In a letter sent May 21 to a SatFACTS subscriber, the First Assistant Secretary of the Licensed Broadcasting and Information Division of the (Australian) Department of Communications wrote:

"Reflecting the Government's approach, remote area viewers are eligible to claim the Commonwealth subsidy for replacement of

RABS analogue decoders with digital units, irrespective of whether they choose the Optus or Telstra systems" (see p. 12 for the full letter). This seems clear enough to me. It makes no difference to Government whether the viewer buys from Scientific Atlanta (which with Telstra provides GWN service through PAS-2), or from Nationwide Antennas (whom Optus advises is the official distributor for the Optus selected UEC 642 IRD).

Unfortunately, Optus has chosen to make the use of RTIF vouchers more complicated.

In a mass-circulated letter dated February 23, Optus' Sales Manager for National Media (at the time) Jeff Davies wrote:

"(Dear Dealer) - Optus decoders are expected to be significantly less expensive than SA decoders and Optus' advice to consumers is to hold onto their RTIF voucher and wait until mid 1998 to make an informed decision. It is not necessary to go to the expense and inconvenience of re-pointing dishes away from the Optus B3 satellite. Optus expects there to be three or four approved decoders eventually, maximising the choice available for consumers and dealers alike and encouraging quality, price and feature competition amongst manufacturers."

In a private letter to SatFACTS dated January 29th, Davies wrote:

"The \$750 decoder rebate originated from the Australian Federal Government's Rural Telecommunications Infrastructure Fund (RTIF). This \$750 will be administered via a voucher system and can be used for those DTH consumers who previously owned a BMAC decoder to buy either an Optus compatible decoder, or SA device."

On May 11th, a two page "Dear Dealer" letter signed by Damien Cook (Account Executive, Optus Communications) leads us to a puzzle. It said:

"The following domestic decoders have been endorsed for use on the Optus Aurora satellite platform: UEC - Model 642, Panasonic/Comstream. The UEC decoder will be imported by Nationwide Antennas (and they) will be able to redeem RTIF vouchers for RABS viewers. The Panasonic/Comstream decoder will be imported by Multilink. Multilink will not be able to redeem RTIF vouchers."

We have Government saying "any receiver / any format will qualify for RTIF." We have Optus saying "eventually, there will be three or four approved decoders" and then announcing models from "UEC and Panasonic/Comstream are currently approved." But, then they add, "the Panasonic/Comstream does not qualify for the RTIF voucher." Which quickly makes it an undesirable selection by the RABS viewer. For Panasonic/Comstream, the "good news" is they made the list; the "bad news" is Optus broke both of their legs putting them on the list. I went to Dr Mark Waggs, headman for the RABS project, in mid-May to ask him why Optus in their wisdom has over ruled the Federal Government's decision about acceptable IRDs qualifying for the RTIF voucher. Waggs has not responded and I for one am curious why. What is Optus trying to sweep under the rug?

In Volume 4 ♦ Number 46

The Painful Death of Australis/Galaxy -p. 6
Digital IRD Update 98-2 -p. 18

Departments

Programmer/Programming Update -p.2; Hardware/Equipment Update -p. 4;
SPACE Notes (Death of Services) -p. 20; Cable Connection
(Loose Fittings) - p. 22; SatFACTS Orbit Watch -p. 24; MPEG-2 Tuning Parameters -p. 26;
Digi Notes Reference Information -p. 28; With The Observers -p. 29;
At Sign-Off (Cunning as the Fox) -p. 32

-ON THE COVER-

DTH pay-TV systems have failed before (the first was in 1983) but never with such splendor and fireworks as the demise of Australis / Galaxy. Those with Internet access have been a part of rather than delayed-in-time observers of the process for this first time. (p. 6)

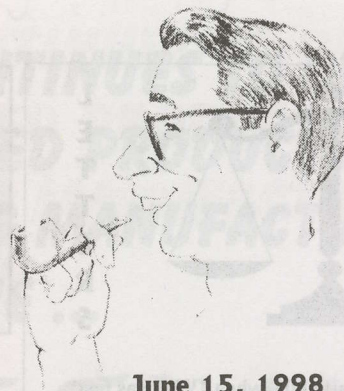

June 15, 1998

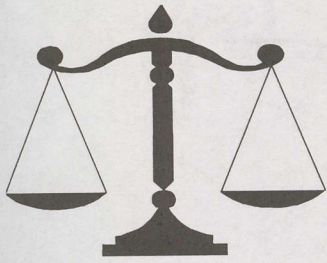

L
E
T
T
E
R
S

How Time Flies

"Back in the early 80s, when TVRO was just coming into its own, I was a satellite enthusiast. And one of the first articles I read on the subject was written by Bob Cooper. This was at a time when the very best grade of LNA (before the LNBs!) was rated at 100 degrees and cost (US)\$349. My actuator was put together by stripping a defunct automobile convertible top mechanism; my receiver was a kit from a chap named John Rohner. The technology has certainly improved, but those were the days when it was exciting because it was a true frontier. Satellite TV went through a great deal in ensuing years - MA/Com, GI, Keith LaMonica, Sean Kenny (a fighter who's early death was a terrible loss) - and here we are all those years later with DSS ruling the airwaves. What is next? Who knows. But it might have never happened without Bob Cooper. If you are ever in the Chicago area, I'd love it if you would look me up - I'd just like to say hello, shake your hand and say 'Thanks!'"

Vince Testa, Chicago, Illinois (via email)

C-band launched in the mid 70s in North America against ever possible foe (the law said it was illegal, the equipment suppliers wouldn't sell non-commercial users equipment, programmers threatened lawsuits if you were caught watching a satellite program). It survived, matured, became a legal service with millions of devotees. During the 80s it spread world-wide under the tutoring of Americans Bob Luly, Bob Behar and Taylor Howard. By 1982, satellite industry trade shows were attracting 10,000 + attendees in venues such as Las Vegas and Nashville. Bob Cooper played a small part in that development.

SA Programmer ID Numbers

"I have a PowerVu D9223 and by changing the Network ID number to '0' can watch many of the programming sources listed in SatFACTS - such as NBC, European Bouquet, Hallmark, some Chinese services. If I knew the network ID number, could I also receive the Chinese SCPC programming on As2 or the recent Optus Vision B3 package? SatFACTS is great for us satellite-mad people!"

Jeff Bannister, Northcliffe, WA

Different software versions of the D9223 allow varying amounts of SCPC or MCPC FTA reception; none we have seen and tested will work with all of the MPEG-2 variations now found on satellite. It is puzzling why you would have spent big dollars for the D9223 that cannot load more than one bouquet into memory at a time when for 1/3rd to 1/2 the price you have a choice of several FTA purpose built receivers that work so much better and offer hundreds of instant-recall memory channels for the nearly 300 sources now available in the Pacific and Asia.

PROGRAMMER
PROGRAMMING
PROMOTION

UPDATE

JUNE 15, 1998

LIVE coverage of ALL World Cup 98 matches are scheduled within RFO digital feed on Intelsat 180E (4095/1055 LHC, 27.500, 3/4). Feeds will come from French terrestrial networks France 2 and France 3 just as those networks are transmitted within France. Test feeds began June 5 with coverage through finals in mid-July. When two matches are played simultaneously, one each on France 2 and 3 (see detail on p. 29). Other good bets for World Cup coverage: RTPi (analogue on As2), RTVE (digital on As2).

Foxtel cable appeared on PAS-2 Ku with first 1, then 6 programming channels June 4-7. Major pressure here on Optus and Austar to "come to the party" or be challenged for DTH supremacy in Australia. Details pages 6 - 15, 29 and 32.

Hallmark - as we now know it - on AsiaSat 2 is heading for a change. New business alliance involving Hallmark Entertainment and Jim Henson Co. (creator of the Muppets) will produce channel split in content between Henson and Hallmark products. Kermit the Frog and Miss Piggy are presently scheduled to begin appearance within Hallmark's service as early as September.

Hallmark disappeared from most Hyundai and Nokia receivers over period May 15-21 but continued to play of Av-Comm R3100 reviewed here last month as well as D7 MediaStar. Subic Bay uplink had modified Msym within bouquet, reducing from 4.0 for KIBC and Hallmark to 3.5 and 3.89 respectively. Complaints to uplink resulted in "fix" May 22 - you should be OK now.

EMTV is (finally) PowerVu conditional access. SA engineer Phil Rees slipped into PNG from Cairns at 1.25PM May 12th and was whisked to the EMTV site where at 3PM local time he got the CA system operating. SA had failed to make the PNG telecaster CA during a visit in April, although they *thought* it had been done. Rees was back to Jackson Airport in plenty of time to catch a 6.25PMer bound back to Cairns. EMTV is now able to show a number of programmes which it had been told by Warner Brothers could not be shown until their CA was operational (including Friends, Family Matters and Renegade).

SPN weekly schedule is available via fax; contact them at + +674-444-3893. Saturday programming is now devoted to "Sports Woman" with hostess Lilly Coffa.

Figure this one out. CTN's entertainment channel, "Dadi," is now being offered to SMATV systems in Hong Kong under the following government mandated terms: CTN may charge HK\$12,500 for the PowerVu decoder required, inclusive of 12 month warranty; there shall be no charge for viewing Dadi; SMATV systems are not to be charged a fee for carrying Dadi. HK\$12,500 is approximately US\$1,200. Now, if Dadi is available in Hong Kong without charge, should it not also be available "out here" free of charge?

PAS-8 Ku could be home for European-origin MCPC bouquet to serve Australia from programming sources in Greece, Italy and Middle East. Premise is 1m range dishes, subscriptions, through consortium of programming firms backed by on-ground Australian reps. Let us all pray SA doesn't get involved in this one!

GMA Philippines shut down Palapa C2 service (3910/1240 Hz) in favour of Agila 2 (146E) on 3787/1363 Hz, May 31. C2 required 1.8m dish along eastern Australia seaboard; Agila 2 a 7.5m monster(!). You can complain to GMA at + +63-2-928-7021 (they are 2 hours behind AEST, 4 hours NZT).

CFI finally was replaced by TV5 on Palapa C2 (4160/990Hz) last weekend in May; CFI service is simply "no more" in Pacific. TV5 also replaced CFI on 1704 at 66E.

Skandia

**COMMUNICATIONS CONTINUES TO OFFER
RELIABLE, AND WELL SUPPORTED PRODUCTS.
IN CONJUNCTION WITH A LEADING MANUFACTURER
NOW BRINGS YOU THE ...**

F1 DIGITAL *FREE TO AIR* SATELLITE RECEIVER

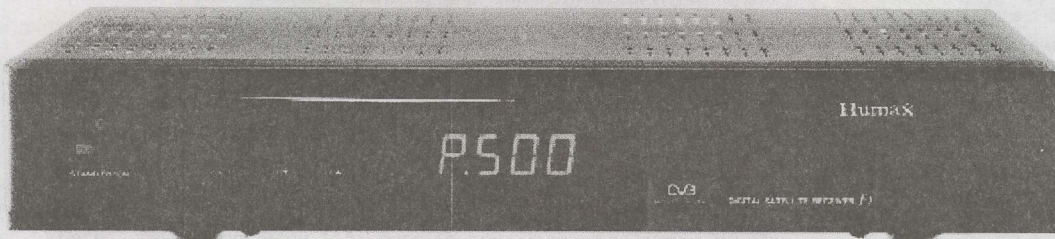

CQ:280598

Its features

- MPEG-2 Digital & Fully DVB Compliant.
- Input Frequency 950 - 2150 Mhz.
- 1 LNB Input (F-Type), IF Signal Loop Through.
- 1000 Channel TV & RADIO Programmable.
- Multiple Network Supported.
- Channel switching time within less 1 second.
- Capable of Receiving Unencrypted Free Digital Programs.
- SCPC & MCPC Receivable from C/Ku-Band Satellites.
- Capable of inserting max. 8 PIDs question Video, Audio and PCR.
- Capable of setting the Frequency for SMATV system.
- Multiple Convolutional Coding Supported Defined In DVB.
- CVBS & RGB Video Output.
- 16 Colours On-Screen Display.
- Electronic Program Guide (EPG) for On Screen Channel Information.
- Subtitle & Teletext Supported.
- MPEG/MusiCam Layer I and II, CD Quality Audio Sound.
- Parental Lock Facility by Channel and Program Event.
- Plug and Play Self Installing Program Setup.
- PLL therefore Modulator UHF CH 21-69 With PAL I/G/B.
- 2 x Scarf (TV, VCR), 3 x Phono (Video, Audio L/R) Connector.
- DiSEqC 1.0 Control Compatible.
- 0/12V Control Voltage Out to DC Jack.
- RS-232 Serial Data Interface Connector.

* HYUNDAI
* PACE
* PHILIPS
* REMOTEC
* SMS
* KONIG
* STRONG
* CHAPARRAL
* SAMSUNG
* PARACLIPSE
* CAL AMP

Skandia

Skandia Communications Pty Ltd

Web Site: www.skandia.com.au

Victoria: 183 Burwood Road Hawthorn 3122, Australia

NSW: Level 1, 39 Terry Street, Rozelle 2039, Australia

SatFACTS June 1998 page 3

E-Mail: skandia@netspace.net.au

Telephone: (03) 9819 2466 Fax: (03) 9819 4281

Telephone: (02) 9555 2955 Fax: (02) 9555 2455



Free to Air

SATELLITE
SPECIALISTS

Satellite To Go

"As a new subscriber to SatFACTS, it is enjoyable reading. However, it would be nice to see more sourcing information for complete NZ systems and summary information on what is commonly received with various dish types and sizes (perhaps in a grid or matrix format?). Would it be possible to install a digital Ku Sky TV system on a camper van or motor home? It seems to me I would only have to point the dish to the proper azimuth and then angle it up approximately 45 degrees until the reception popped in. Can SatFACTS recommend two dealers who have experience with portable systems suitable for a motor home, and who have suitable experience to advise on both a C and Ku system for a motor home?"

Gordon Stinson, NU-BRIDGE, Gisborne, NZ

At C-band, any dish smaller than 3m produces only a small number (5 to 10) watchable services. And you won't be hauling a 3m dish around on a motor home. At Ku, there is no reason why a 60 to 90cm dish could not provide Sky reception from Optus B1. In fact, TV performer Gary McCormick when he visited us here in February had one on his motor home which worked just fine on the Sky analogue service while parked in our driveway. Sources? Try Strongline Aerials (04-569-4916) as well as distributors Bay Satellite (0800-229-728) and Telsat (06-356-2749).

BBC to Cable TV

"Persistence has paid off! Almost one year and many letters and faxes since I first contacted BBC World (Sydney) finally Waipu Cable Television is the first small cable operator to be granted a licence. I am happy that constant reminding the BBC that cable operators in New Zealand want to carry their service has finally come to fruition and this now opens the door for us to carry a fine news channel. Power to the little people!"

Paul Burton, Waipu Cable TV, Waipu, NZ

Indeed. Congratulations for success. BBC was wrapped up by New Zealand terrestrial network TVNZ for years and the change in policy towards cable is refreshing.

Contact for BBC World is Rob Milne at fax + +61-2-9957-6448.

Kudos For Scientific Atlanta

"As many have read between my lines in SatFACTS over the years, my association with Scientific Atlanta has been more often down than up. Recently I attempted to get 'just one more bit of operational information' concerning the D9223 series receiver and needed to obtain help in sorting out the problem. I am pleased to report after numerous emails and telephone calls, I finally have my problem sorted. To that end I wish to be on record thanking SA Australia and in particular SA Canada for a successful conclusion to my problem."

Robin Colquhoun, Auckland, NZ

First kind words about PanAmSat (SF#45, p. 35), now public thanks to SA. What is SatFACTS coming to?

Good grief.

Notice: Letters to SatFACTS ...

may be edited for clarity, and/or to fit the available space. Content is not altered.

HARDWARE EQUIPMENT PARTS

UPDATE

JUNE 15, 1998

Nokia. Just when you thought they were "gone," they are not. New data sheet describing "2000 S Free to Air" receiver is pointedly aimed at "Asia Pacific." Receiver does SCPC, MCPC, automatic channel set-up, PAL and NTSC and has temperature sensor operated rear deck fan. Will it do PowerVu? We are waiting for field reports. Will it be "supported" by Asia or Pacific distributor? That is the big question.

Single chip IRDs? MPEG-2 receiver world is about to be turned upside down. London Satellite & Cable Show in May was opportunity for numerous manufacturers to show off latest IRDs and the high interest units featured "single chip IRD." What's that? New, purpose designed "super chips" combine MPEG processing functions previously handled by two, three or four separate chips into one chip. This means significantly fewer circuit board parts, lower power drain, less heat and dramatically lower cost of manufacture. How much lower? Many believe IRDs at point of manufacture will come down US\$60 each which ultimately will translate to retail/dealer savings of as much as 20%. Nokia 9800 S single chip prototypes now being circulated for evaluation increase RAM and Flash memory capacity from 1 to 2 Mbyte, add 4 Mbyte SDRAM for video and graphics processing, builds in PCMCIA common interface for conditional access (with Viaccess built-in), brings out digital audio in data stream format on rear panel - and, reduces power drain by 5 watts (12.5%). Look for first deliveries of single chip IRDs September-October and major changes in IRD pricing by January.

Fallout from Suharto demise? Squabble has broken out between RCA-Thomson and Indovision concerning shipping of new IRDs for Indovision service. RCA-Thomson is supplier of choice replacing original Pace units; as of end of May, no decoders are being released by Jakarta offices of Indovision casting further uncertainty about near-term future of Indovision. Related report: S-band Catawarta bird reported in European press to have defective solar array, claims satellite will have to power down from 5 to 2 transponders during twice-annual solar eclipse periods. Jakarta source advises Indovision is signing up no more than 1,000 new DTH subs per month, but is losing 400 because of churn and lost 7,000 analogue B-MAC subscribers when it dropped that service (these subscribers refused to convert to digital). Further, Indovision needs 450,000 subscribers to service a sizeable debt but never had more than 37,000 at peak of growth cycle. Does this sound like Galaxy all over again? Perhaps it is time to bring back the four channel B-MAC analogue service on C2?

AsiaSat 4, to be located at 122E where temporary resident AsiaSat G (ex-Rimsat) now operates - is being delayed to 1999 or perhaps 2000. Troublesome Asian economies continue to plague new satellite plans and AsiaSat 3 replacement for 105.5E apparently will handle all of the needs of the firm for a couple of years. Ex-Rimsat at 122E will apparently continue to provide Moscow's NTV but at ever increasing inclination (NTV is a "free bonus" to this satellite occupying 122E).

SNG eavesdropping (tuning in portable uplinks transmitting raw video [+ audio] back to the studio) could become more complicated. Sony has introduced a twice data speed package (DSM-T1 modulator for the uplink and DSM-R1 demodulator for the receive studio) which doubles the data stream speed. Without the required demodulator, it looks to be CA to a standard receiver. Reason for device is not security - Sony tells broadcasters they can cut in half their satellite rental time by transmitting digital data streams at twice real speed. Seems logical to us.

ADL[®]

BECAUSE PERFORMANCE IS ALWAYS YOUR FIRST PRIORITY

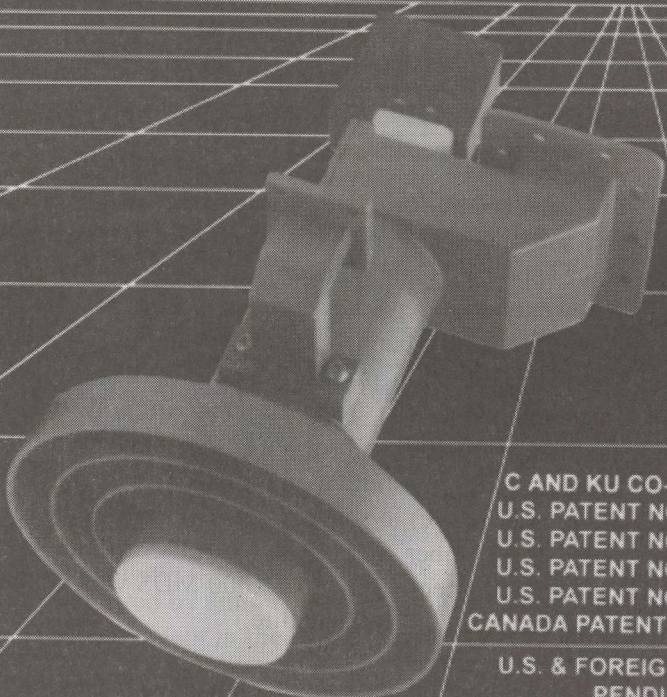

**RP3-CKU/ International
Adjustable Scalar Ring Feed
with Extended C Band**

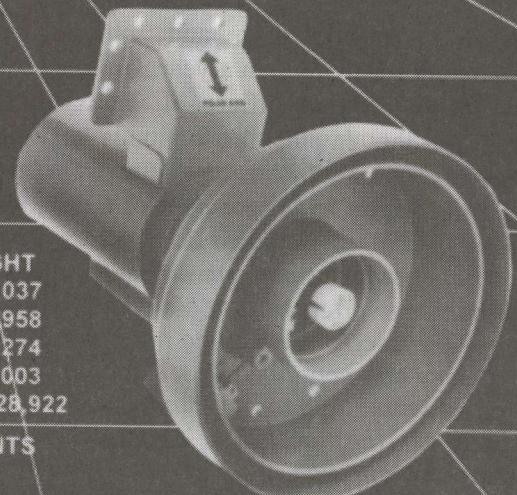

RPI-CKU Feed

C AND KU CO-BORSIGHT
U.S. PATENT NO. 4,903,037
U.S. PATENT NO. 5,066,958
U.S. PATENT NO. 5,107,274
U.S. PATENT NO. 5,255,003
CANADA PATENT NO. 1,328,922

U.S. & FOREIGN PATENTS
PENDING

ADL HYBRID MODING CIRCULAR POLARIZED INTELSAT FEEDS WITH EXCLUSIVE T.I. REJECTION



RP1-CP400

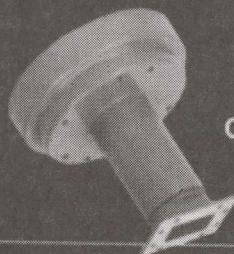

CP-300



CPOR-100

- C BAND LINEAR & CIRCULAR • C/KU LINEAR & CIRCULAR • KU 12 GHz FEEDS
- INTELSAT 4 GHz CIRCULAR • ARABSAT S BAND FEEDS
- OPTIONAL: CO-BORSIGHT S BAND

2216 AGATE COURT, UNIT B, SIMI VALLEY, CALIFORNIA 93065 • (805) 526-5249 • FAX (805) 584-0634

E-mail: ADL@thegrid.net • Web site: <http://www.thegrid.net/adl/>

THE PAINFUL DEATH OF GALAXY/AUSTRALIS

Tuesday May 05,
1998, 2.55PM.

At the Osborne Park office of Galaxy in Western Australia a fax machine begins transmission of a message destined to

change forever the shape of pay TV in Australia. It is the message Foxtel, Optus and others have been encouraging for more than a year. *Galaxy has gone into receivership*. Eastern offices of Galaxy have already closed for the day as the ominous text appears on printers throughout WA:

"Due to today's announcement of Galaxy going into receivership, all Regional Contractors are hereby notified not to perform any service calls or disconnects effective 6th May 1998 until further notice. Transactions which do not incur a payment by Galaxy can continue. Please submit up to and including work done through today the 5th May 1998 to Galaxy for processing. We envision this to be temporary situation, we will have more information over the next few days. Please refer all customers to the Customer service centre on 1300 555 111."

Cash starved Galaxy has been close to financial ruin for more than a year. During the past six months, staff reductions and office closures have highlighted frequent predictions it would fail. The May 5th "Red Alert" was the second bit of unpleasant news for Western Australia's estimated 20,000 Galaxy viewers. A story in The Sunday Times for May 3rd headlined, **"Galaxy pulls plug on Perth pay-TV office"** and reported state manager Joe Zuravie commenting:

"The state of pay-TV is in turmoil. Galaxy is still in business and it is going to be around for quite some time."



"Quite some time" would be measured in days. At 12 midnight on May 21, Galaxy subscribers throughout Australia saw their screens go dark. Some programming, such as Fox Sport 2 and TV1,

had been erratic for days as programmer supplier Foxtel and satellite operator Optus fine tuned the pressure on court appointed Galaxy receivers.

Twenty-nine separate companies operated under the Australis/Galaxy banner are now winding up business under the direction of court appointed bankruptcy and financial managers. Not affected initially were an estimated 10,000 subscribers to New World TV programming transmitted via MDS (terrestrial 2 GHz range microwave) in some areas. Nobody seems precise about the number of people suddenly without service, but estimates centre around 25,000 MDS viewing homes and another 55,000 via satellite.

Chaos

Reports that Galaxy would shut down at midnight on the 21st were broadcast on ABC Radio and other circuits as early as 7PM on the 20th. Panic calls to Galaxy's usually helpful Customer Service Centre in Adelaide brought the "official" response:

"Reports on the radio and elsewhere are incorrect: it is business as usual at Galaxy."

Galaxy had been utilising a pair of transponders on Optus B3, horizontal: 12.376 and 12.438. For several weeks Optus Vision, the cable arm of Optus Communication, had been "testing" as many as 16 programming channels using 12.564 and 12.626 on the same satellite. In February, regional pay-TV operator Austar had tested on B3's 12.689. Galaxy at its demise was grouping 22 programme channels as 11 x 2 on .376 and .438. Optus "testing" placed 16 programme channels as 8 x 2 on .564 and .626. Austar required an initial spectrum for no fewer than 16 programme channels and

FROZEN in time. Last programme update for Discovery was for 22.00 (10PM) on May 20th.

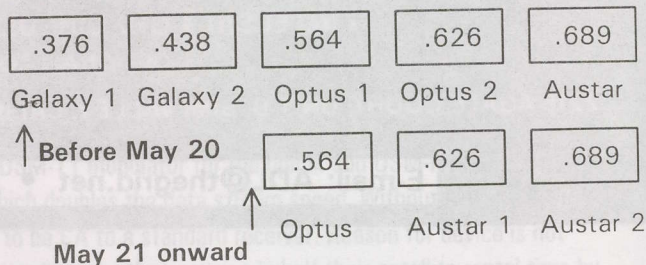
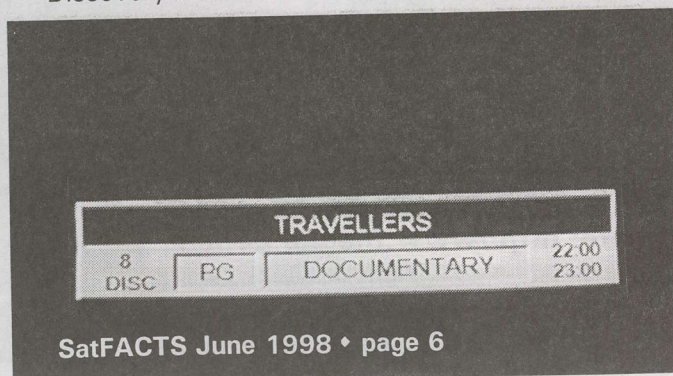

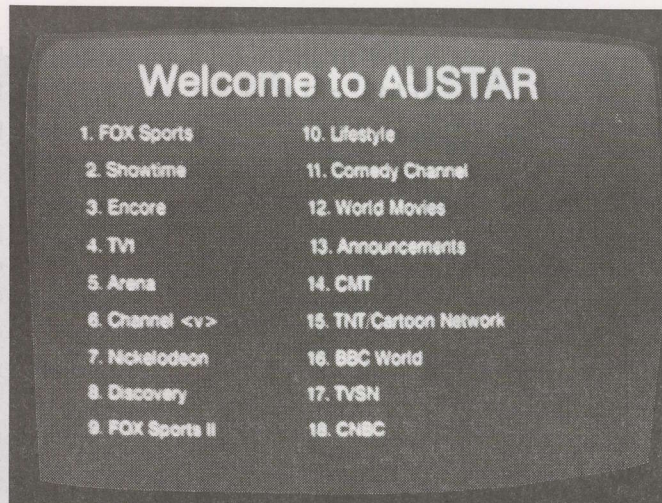
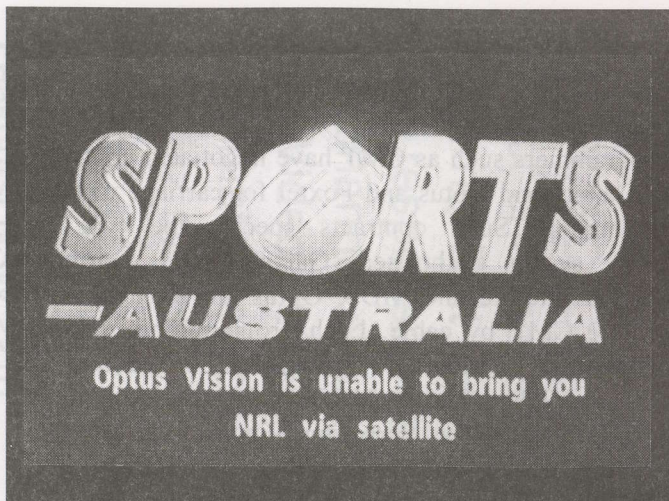

TELEGRAPHING INTENT - Optus Vision "satellite DTH tests" were clearly not an oversight or mistake when they took the time to create special "announcement" for satellite viewers May 3rd (left). As this announcement appeared, the "official" Optus line was that "no satellite service is planned or underway." Many ex-Galaxy viewers found they could access replacement Austar service several hours before Galaxy shut down (right).

this could only be accommodated by "borrowing" from Optus Vision one of their two "test" channels. (1) Austar and Optus would reach agreement for .626 as well as the .689 transponder where Austar testing had previously taken place.

Who is Austar? Actually, they are the second largest pay-TV operator in Australia, and more than twice as large (as measured by subscribers) as Galaxy. When the Australian government in their bureaucratic wisdom first authorised pay-TV to develop, licenses were created for "urban" and "non-metropolitan" regions. Austar bid for and won licenses for non-urban regions throughout Australia missing only in WA, Tasmania. Austar is primarily owned by a US based major player in international pay-TV; United International Holdings. (2)

To programme Austar, UIH had worked out an arrangement with Australis/Galaxy to be a "secondary user" of their satellite service. An Austar customer deals with a local or regional Austar office, was equipped with essentially the same DTH system as a Galaxy DTH viewer, and through the Galaxy feed on B3 received a set of programming out of the Galaxy bouquet. (3) If Galaxy's satellite feed terminated, an estimated 210,000 Austar subscribers would also go dark.

1/ "Legal complications" was the reason given why Austar could not simply "take over" the Galaxy transponders of .376 and .438.

2/ UIH operates pay TV systems throughout Europe, Asia (23 countries) and is primarily owned by a consortium of US large scale (MSO) cable operators.

3/ Austar charges A\$129.95 for installation, \$44.95 per month for their service as it existed prior to May 21. Second decoders are \$19.95 per month.

When it became clear Galaxy's plug would be pulled, Austar had to find two transponders to carry the programming previously received from Galaxy. Furthermore, it had to cut a deal with the programme owners to continue delivering programming which it previously purchased through Galaxy.

At 1PM on May 20th Austar fired up on 12.689 and Optus killed their "test" programming on 12.626. Over the next 11 hours the addressing stream on 12.376/12.438 told IRDs tuned to Galaxy to retune to 12.689/12.626. A crawl across the screen advised:

"To continue this transmission, turn to channel 22, wait 5 seconds, then go to channel 1."

This was a message telling (Austar) viewers they would automatically be shifted to the two new transponders. What actually happened was Galaxy subscribers who followed the same instructions found themselves "shifted" to the two newly activated Austar transponders as well. When Galaxy's plug was pulled on programming (but not the actual MPEG-2 carriers) at 12 midnight eastern, a not insignificant number of Galaxy DTH viewers had moved to Austar.

The Irdeto Whammy

When Australis/Galaxy went into business in 1995 it began by using a GI (General Instrument) MPEG system on Optus B1. At this point, there was no Galaxy DTH, only Galaxy feeds to MDS sites using GI Digicipher (1.5). In October 1995, Galaxy launched a B3 DTH platform after exchanging their GI system for a newly developed Pace + Irdeto encryption package.

Irdeto, as most realise, is a conditional access technology involving a CAM (conditional access module) plus a "smart card" that inserts into the CAM. Irdeto was new late in 1995 and simultaneously debuted in Australia and South Africa. Australis/Galaxy

purchased "exclusive rights" to utilise Irdeto in Australia for DTH service (see SF#42, p. 14). Galaxy considered this "exclusive Irdeto licence" part of its "assets" because without an Irdeto licence two things could not happen:

1) Anyone wishing to use Irdeto in Australia would require Galaxy sub-licensing (permission) and Galaxy was not about to licence a competitor to use their CA system.

2) A receiver supplier with an Irdeto licence would not chance selling receivers into Australia without Galaxy's permission because to do so would risk their Irdeto licence for other parts of the world. (4)

Therefore, before any pay TV programmer could take over the "assets" of Galaxy, before Austar could continue functioning with Galaxy "off," new agreements for the Irdeto licence had to be arranged. To Austar, there were two parallel priorities if Galaxy was going to fail:

1) Negotiate legal rights to continue using Irdeto (rights they had originally obtained through Galaxy), and,

2) Negotiate with the programme rights holders continued use of programming which Galaxy had controlled (notably - Showtime and Encore movies, TV1).

Some legal minds believed Galaxy had to actually "leave the air" and cease broadcasting before Austar could renegotiate these two areas. Others believed that as long as Galaxy (through the court appointed receivers and the bankruptcy officer) was a party to the negotiations, these two areas could be settled before Galaxy actually turned off their service. At some legal risk, Austar and Galaxy with Optus in attendance began the negotiations May 11th. At the same time, Optus began discussing how it might take over the 55,000 Galaxy DTH subscribers.

To expedite the Irdeto transfer, Austar and Optus formed a "50 - 50 joint venture" and through the Galaxy court appointed financial managers, negotiated access to the Irdeto licence for Australia. They appear to have paid A\$5,000,000 to become the new "exclusive rights holders" to Irdeto in Australia.

Limited Licenses

Galaxy had originally bid in auction to acquire the legal right to supply DTH service in Australia. Their

4/ Nokia, for example, has a license for Irdeto equipped receivers for specified European markets. If Nokia attempts to bring (or allow) their new single chip 9800 IRD into Australia, and the Irdeto licensee in Australia found out about it, Nokia could lose their right to an Irdeto licence.

"exclusive" right to do so ran only until June 30, 1997. However, there was another exclusive involved; one granted by the programmers.

Programmers such as CMT have negotiated contracts with Galaxy and Optus and Foxtel for carriage of their programming. Such contracts specify the type of delivery system authorised; Galaxy could distribute CMT via satellite and MDS, Optus and Foxtel could distribute CMT by cable. Each programming contract specifies the distribution methods authorised and in most cases Galaxy had an "exclusive" right to distribute programming (such as Showtime, Encore) via satellite. It held the right to sub-licence Austar as well. But Foxtel could not simply set up a DTH service and include Showtime (et al) on a satellite service without violating their own licensing agreements.

Therefore, for many of the Galaxy services to appear on a competitive-to-Galaxy DTH service, first Galaxy had to give permission (something they would not do, of course). The only other option, as Foxtel saw it, was for Galaxy to go out of business. As long as Galaxy was in business, Foxtel could not launch a DTH service of their own using many of the programming channels it is authorised to carry on cable.

Galaxy had a nation-wide Australia license covering all of the major population centres; the so-called "B" license. Austar has an "A" license, similar to that of Galaxy but limited to serving DTH (MDS, cable) customers in non-urban markets. As long as Galaxy and Austar were both financially healthy, they made a good pairing. Galaxy served the metropolitan areas, Austar the more rural areas and between them they shared the cost of similar (and nearly identical) programming sources. And the Galaxy Optus B3 satellite feed was the "carrier" for both licensees.

Why could not Austar simply take over the 55,000 Galaxy subscribers? Did they not already receive essentially the same programming, use the same Pace DGT-400 IRDs, and depend upon the same Irdeto conditional access system? Would that not be the quickest and easiest way for Galaxy's disenfranchised viewers to continue to have service?

Logically, yes. Legally, no. The Austar licence granted by government precludes it from having customers in the urban (metropolitan) regions. When Austar activated .626 and .689 May 20th, and Galaxy customers found themselves watching Austar programming, it was because at that time there was no other way to maintain service to the Austar subscribers. Austar explains it this way.

1) *"We had very little time to get our own subscriber IRDs switched over to the new transponders.*

"Optus had the (contract) right to terminate Galaxy's use of Optus (B3) if Optus believed Australis did not have the ability to pay for the satellite's use. It is believed Optus had officially terminated the agreement May 7th, but had not implemented the decision because it would mean Australis subscribers would have their pay TV cut off."

The Most Advanced Free To Air Digital Satellite Receiver

D7-MediaStar

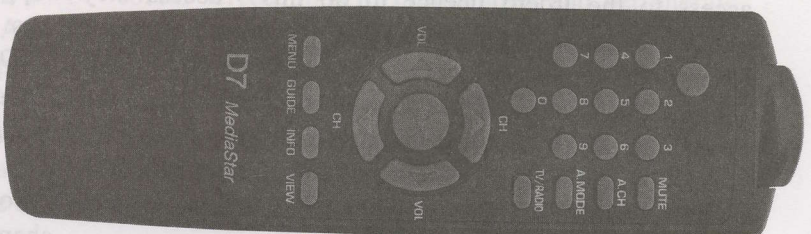
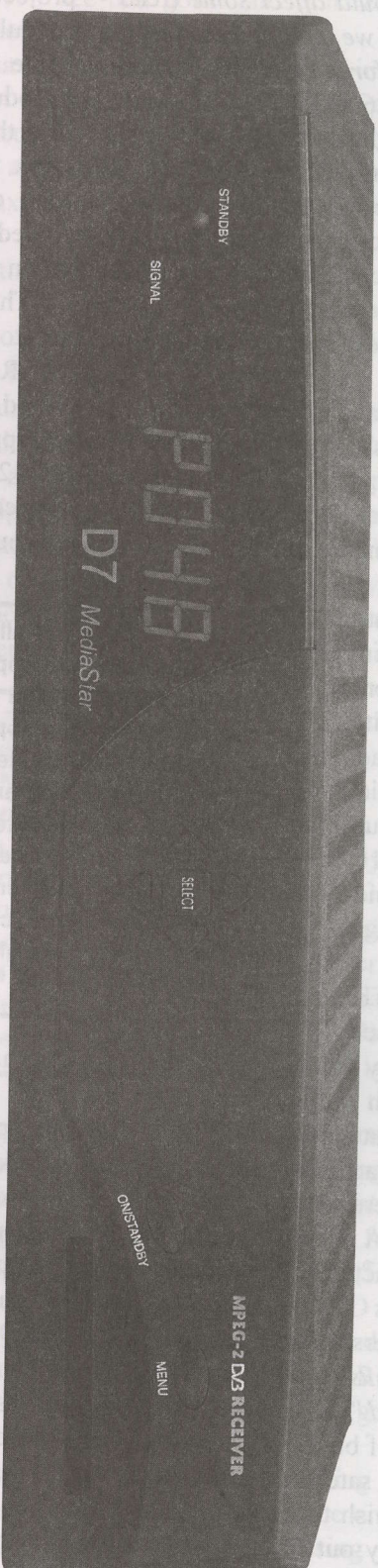

- MCPC/SCPC 2-36 Msym
- Direct channel selection from channel list
- Channel Edit menu Delete, Skip, ON.
- Fast response when changing channels
- No channel over-write
- 200 Video 100 Audio channels
- Automatic search and download
- 22 KHz switch
- PID Menu
- NTSC/PAL Auto switching NO NTSC Glitch
- NTSC converted to PAL-60Hz Free Option
- Audio L, R, Stereo selectable via remote control
- RF Modulator PAL-G, VCR/TV Scarts, RCA Audio/Video, SVHS outputs.
- 90-265VAC-50-60Hz power supply
- Low threshold performance

Opac Pty Ltd
99-105 Boundary Road
Peakhurst NSW 2210

E-mail opac@bigpond.com
Tel ++61 2 9584 1233
Fax ++61 2 9584 1452

2) "Although we knew we would affect some (read - most) of the Galaxy subscribers, we modified the Galaxy (.376 and .438) data streams to force receivers to retune to the two new transponders (.626 and .689)."

At this point, nearing midnight on May 21st, Austar was comfortable it had "gotten the message" to the majority of its own DTH subscriber's IRDs and aware they had some non-Austar subscribers "hitching a ride" as well from the former Galaxy customer base.

Although Austar + Optus had negotiated acquiring the rights to Irdeto by midnight May 21st, two things had not happened at that point.

1) Nobody at Galaxy was willing to take the responsibility for sending a message to all Galaxy IRDs shutting them down, and ...

2) Nobody at Austar was willing to take the responsibility of assuming control of the conditional access system.

The easiest way out, temporarily, was to simply turn off the CA system altogether. Maybe Galaxy had sold it, maybe Austar + Optus had bought it. Maybe. From mid evening on May 20th until our June 8 deadline the Austar 16 programme channels on .626 and .689 would be free to air.

Meanwhile - At Optus

Optus began testing DTH service during June (1997; see SF#34, p. 27). At that time they randomly selected feeds taken from the Optus Vision cable TV line-up and broadcast them (usually without audio) in a FTA format. By March 1998 the testing had become more serious, and now two transponders were lit up (.564 and .626). Audio was present, and 16 FTA channels were in the air. This was not a benevolent act for the benefit of the public at large; Optus was deliberately sending a "message" to Galaxy (and others). That message?

"We could be in the DTH business tomorrow - if we wished."

Foxtel wanted Galaxy out of business because Galaxy held exclusive rights to satellite distribution of programming Foxtel would wish to use itself in a DTH service. Optus wanted Galaxy out of business because that was the Optus business plan; to build a new DTH service on the ashes of Galaxy. And Optus needed access to the Irdeto licence to do this - access they would be denied as long as Galaxy refused to grant Optus sub-licencing rights.

Back on January 21, Optus was successful in getting Galaxy to agree to allow Optus to utilise Irdeto for something seemingly non-competitive to Galaxy DTH; the RABS (HACBSS or outback TV distribution)

project. Optus believed if Galaxy went out of business, it could pick up the pieces with an Optus DTH service. More than one year ago, Optus decided it would not introduce a new, non-Irdeto conditional access system into the Australian market. Rather, they would simply work their way into the Irdeto world. If Optus waited long enough, they were convinced Galaxy would be forced to give up their exclusive right to Irdeto or lose it when they went out of business.

The January 21st agreement allowing Optus to use Irdeto for the limited purpose of supplying receivers to the RABS project was an important step. Now Optus could openly "go to the marketplace" to source Irdeto equipped IRDs. As SF has previously reported (SF#43, p. 32 and SF#45, P. 36), Optus encouraged South African manufacturer UEC and UK supplier Matsushita (through their Wales based Panasonic brand) to bid on

supplying Irdeto equipped IRDs to the RABS project. Lurking in the background were Pace and Sun Moon Star, and Optus during the February Cable & Satellite Show (Sydney) proudly displayed in a booth IRDs from all four suppliers each operating (after a fashion) on a RABS "test bouquet" put up for show purposes.

It was bothersome to many that Optus seemed to be encouraging as many as four IRD suppliers to become involved in the supply of

perhaps 10,000 IRDs. Experience world-wide has taught us that IRD manufacturers must support these temperamental products with on-ground technical backup. Placing RABS IRDs into outback locations hundreds of kilometres from the nearest technical help seemed like a sure fire formula for disaster. If four suppliers each sold 2,500 IRDs to RABS, no supplier would be able to afford the backup necessary to keep the IRDs running properly.

On the other hand, if RABS was nothing but a stalking horse - a lead in to Optus DTH which would require several hundred thousand IRDs over the next three years - that was another matter. Optus was smart here. While not admitting directly they would be requiring far more than the 10,000 RABS receivers, they said all the right things to representatives from the four IRD manufacturers to lead them to "guess" what was happening. The message, never quite said this way, was:

"Do the RABS deal correctly, get us the receivers we need for RABS and down the road we'll be creating a market for you that will justify your interest in the small RABS project."

So the "message" inherent inside of the 16 programme channels Optus floated on FTA for several months on .564 and .626 was abundantly clear to each participant

"Optus is initially installing highly sophisticated digital set-top boxes in 40 homes around Australia to test the technology it has developed with its largest shareholder, Cable & Wireless plc. The set-top boxes are equipped with modems, sophisticated encryption signatures and an Internet cache and will eventually have smart card capabilities to allow subscribers to take a range of services through one piece of architecture."

in their own way. Galaxy saw it as a threat to their DTH exclusivity. Foxtel saw it as a wake up call to get their own DTH project underway. The receiver suppliers saw it as further "proof" Optus was dangling more than a carrot in front of them with the RABS order. And Irdeto (which maintains an office in Sydney) saw it as an escape valve for Irdeto licensing when (not if) Galaxy fell over.

What few - perhaps none - saw accurately was the major upheaval underway in the IRD world.
US\$200 Irdeto Equipped IRDs?

As reported in Coop's Technology Digest (#46, p. 14), the high technology firms who design and manufacture signal processing chips for MPEG-2 receivers finally have their acts together. Today, an IRD has as many as five separate multi-pinned, rectangular or square chips all linked together to turn the L-band (IF) digital data stream into picture and sound for TV watching. Each of these chips consumes electrical energy (power), each chip generates heat (which must be dissipated to prevent thermal run away of the IRD), each chip requires support parts (capacitors, resistors, tuned circuits) and all of this adds up to an expensive box to manufacture. By the best educated estimates, an IRD equipped to handle some form of conditional access costs the IRD maker between \$130 and \$140 today. That's direct costs of parts and labour. That does not include the equipment required to build the IRD, the building where the manufacturing equipment is installed, the land the building sits upon, the corporate staff required to make the assembly plant function and the thousand and one overheads that go with being in business. One IRD manufacturer told SatFACTS late in May, "*Unless we sell an IRD for at least 2.5 times our actual per-unit manufacturing cost, we lose money. At 250% of our manufacturing cost (2.5 x \$130 = \$325), we earn back a maximum of 15% (\$48.75).*" All of these numbers are in US dollars.

RABS IRDs were pushed by Optus to end up costing the HACBSS consumer not more than A\$750, installed. The reason for this - something called the "RTIF Voucher," a federal government subsidy programme designed to earn political points for the present Australian government with outback residents who as a group don't understand why their 13 year old B-MAC receivers have to be retired in the first place (see p.1, here). If the replacement "digital gadget" costs A\$750, and the government hands to each present HACBSS user a voucher valued at \$750, the net cost to the politically vocal outback voters will be nil. The man responsible at Optus for RABS, Dr Mark Wagg, has done his best to

see that politicians don't end up getting flack over this exchange.

If a RABS IRD arrives in Australia for US\$325, that is the same as A\$534, give or take a few dollars of exchange rate variation. Now add a profit for the efforts of the distributor of the RABS box, the installer of the box, and transport of the box and personnel required to make the exchange and - and you are pushing A\$750 very hard. None of this has been helped by the fall of the Australian currency against the US dollar since Dr Wagg and staff began talking with IRD suppliers last December. The receivers have stayed in US dollars, while the Australian dollar has lost value weekly.

A 20% reduction in the US dollar price for the RABS IRDs would have a major positive effect on the project. For the past 90 days there have been rumours that multiple-chip IRDs would be replaced with "single chip IRDs" by the end of the year. A single chip IRD will cost less at the point of manufacture for several reasons:

1) The number of chips is reduced, lowering the chip portion cost as a percentage of the total cost;

2) The power supply can be down sized because with fewer chips to operate, a large power supply is no longer required.

3) Heat dissipation can be re-engineered; fewer chips, less power used, lower amounts of heat generated.

4) Assembly, test, check-out time is reduced.

At the London Cable & Satellite Show (May 16 - 20), virtually all of the larger IRD manufacturers had operating prototype one-chip IRDs in their stands. Most forecast their single chip versions, when available, will sell for "at least 20% less" than their present models. A \$325 RABS multi-chip IRD would become a \$260 IRD and that (US)\$65 difference quickly becomes a hundred dollar bill in the pocket of someone between the IRD creator and the dealer collecting payment with a government drawn \$750 RTIF voucher.

As nice as a 20% saving sounds, it gets better. *Much better.* At the base of the one-chip technology is a price war in digital processing boxes. Some believe it is overdue pointing out it is now possible to purchase a complete home PC system with giga-bytes of memory, a 14" colour screen, tons of programmes and peripherals for only marginally more money (or no more at retail) than an Irdeto equipped IRD. IRDs have been badly overpriced, but not to the profit of the manufacturers or distributors; they simply have too many parts.

US\$200 is believed to be the "real" plateau to separate the serious players from the game. SF in preparing this

CTD #46, p. 14, April 1, 1998

"Major chip designers are promising much lower (5v) MPEG-2 decoders that will end heat problems. To speed up MPEG decoding, new chips perform calculations in two parallel operations. A single 100mm square chip using 0.25 micron CMOS technology will contain the equivalent of 5.5 million separate transistors in 'system-on-a-chip' designs that will greatly reduce product costs."

report late in May and early in June has located two Asian suppliers of IRDs who say they will hit the streets with CA equipped one-chip IRDs for distributor pricing of US\$200. When? That's the killer question right now.

Timing - Crucial To Optus

As Galaxy fell apart and turned off its data streams at midnight May 21st, Optus was announcing it failed in its discussions with Galaxy bankruptcy appointees to come to an agreement to take over the 55,000 Galaxy DTH subscribers.

Galaxy's DTH subscribers became "orphans" receiving temporary shelter through the Austar emergency relief programme. Optus offered Galaxy a deal to "take over subscriber management of these subscribers for a nine month period." Galaxy's court appointed financial people declined the offer saying, "the offer was not enough for Galaxy." The job of the court appointees is to secure as much cash money as possible while dismantling Galaxy; hundreds of millions of dollars are owed to various creditors, bond holders, suppliers. Optus, expressing minor disappointment in not being allowed to assume the Galaxy subscribers, stated, "We offered what it was worth. Galaxy is using technology that is old, several generations behind our own new technology we are bringing to DTH."

Galaxy in dealing with the RABS IRD suppliers went back to them in March with a new request. "Add 4 Mbytes of additional RAM to the IRDs." RAM is memory and memory is the ability to store information inside of the IRD for call-up on-demand. Optus has been telling financial people, "We are not just going to deliver television - we will be delivering Internet, and offering in-home shopping and even in-home banking with our technology."

Quietly, they hoped without attracting notice, 4 Mbyte of add-on RAM was being demanded of the RABS units. For RABS? Of course not. Remember - RABS has

been a stalking horse designed to get the attention of the IRD creators, a cover to get Optus DTH into operation.

Timing. For every multiple-chip IRD placed in a RABS home between now and September or October, *somebody* will pay A\$100 or more too much. Too much? More than they will pay *after* the single-chip IRDs begin to arrive. And when might that be?

The most optimistic IRD builders are telling us September. The consensus is that October or November are much more realistic than September. UEC was prepared to ship 1,000 multi-chip 642s to Nationwide Antennas (the RABS UEC distributor) late in May as this report was being readied. Matsushita (Panasonic brand) had a similar number scheduled for delivery late in June. Neither of those numbers puts much of a dent in even the relatively small 10,000 quantity required to complete the RABS exchange programme.

If you are a manufacturer and committed to delivering RABS units for Optus, wouldn't you rather drag your feet and holdback shipment until the new one-chippers are ready? If you really believe the first one-chippers will cost you 20% less to manufacture, and you will increase your net profit per unit shipped from (US)\$48 to \$74 per IRD, of course you would.

But what does a delay in RABS unit deliveries cost Optus? "Face" for one thing. As reported in SF previously (SF#43, p. 32), Optus is engaged in a tug of war with terrestrial competitor Telstra (plus Scientific Atlanta + PanAmSat) to earn the market "right" to supply RABS. Telstra and crew have already "won" the Western Australia franchise from GWN and any slippage in Optus launching RABS for the balance of Australia only throws gasoline on the Telstra fire (see letter from Department of Communications and The Arts, below). Today, Telstra is winning the RABS war because it is *operating* a digital platform while Optus is not. And if a lack of RABS receivers is holding back



DEPARTMENT OF COMMUNICATIONS AND THE ARTS

Letter Explaining Department of Communications and The Arts "Policy" received May 27th by SatFACTS reader

"Consistent with the Government's broader commitment to enhancing a competitive and deregulated communications environment for the benefit of the Australian community, the Government has taken the view that technical and commercial arrangements for RABS digital conversion should be a matter for the satellite carriers and broadcasters concerned. It has not, therefore, sought to mandate or approve any particular digital transmission systems for RABS. In this deregulated environment, Optus is competing with Telstra for the digital transmission of

RABS. Optus is using the Irdeto conditional access system on its Aurora platform via the Optus B3 satellite and Telstra, leasing capacity on the PanAmSat PAS-2, is using the Scientific Atlanta PowerVu conditional access systems. Both carriers are digitising their satellite operations and developing a range of services which can be accessed through their digital systems in remote areas, including data transfer, Internet access and possibly pay TV. Reflecting the Government's approach, remote area viewers are eligible to claim the Commonwealth subsidy for replacement of RABS analogue decoders with digital units, irrespective of whether they choose the Optus or Telstra systems. In practice, there is only a need to choose between systems in Western Australia where Telstra won the contract for digital transmission of remote commercial television service. The Aurora system will be used exclusively for RABS digital transmission in central and eastern Australia. I should add the Government recognised, from the outset, that some outcomes from deregulation of the communications market could raise particular problems in relation to the RABS digital conversion. Therefore, while conversion arrangements are primarily commercial matters for the carriers and broadcasters, the Government has sought their co-operation throughout the conversion process to minimise the potential disruptive effects on viewers."

(signed) R.J. Badger, First Assistant Secretary, Licensed Broadcasting and Information Services Division
(21 May 1998)

NATIONWIDE ANTENNA SYSTEMS

17 Campbell Street, Bowen Hills, Qld 4006

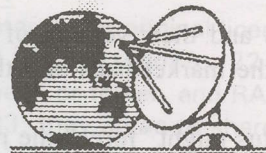

PRODUCT RELEASE

Aurora LNBFs



Ready yourself for the exciting viewing options that the AURORA platform will offer. Not only will UEC IRD owners be able to view the traditional RABS service but you will have access to Optus Vision or other Pay TV services. All that you will require is a UEC IRD, dual polarity LNBF and appropriate smart card. In keeping with our one stop satellite shop philosophy we have sourced two prime focus LNBFs. You will require a dual polarity LNBF as the RABS and Optus Vision services will be located on alternate polarities.

RABS = Remote Area Broadcast Service

YURI JAPAN

Prime Focus 0.6 dB LNBF

SATLNBFKUDUAL
SATM/RINGMLF

IN: 12.25 - 12.75 GHz
OUT: 950 - 1450 MHz
LO: 11.3 GHz
POL: VER / HOR
SWT: 14 / 18
OT: TWIN
ANT: PRIME FOCUS

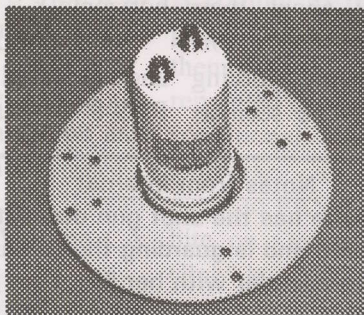

Our YURI LNBF is the most versatile KU Band Prime Focus LNBF currently available. It houses two separate 14/18 Volt switching LNBFs. This LNBF will allow two IRDs to run off one dish. Both IRDs will be able to switch between RABS and Optus Vision.

WP4-U

1.0dB LNBF

SATLNBFKUWP4U

IN: 12.25 - 12.75 GHz
OUT: 950 - 1450 MHz
LO: 11.3 GHz
POL: VER / HOR
SWT: 14 / 18
ANT: PRIME FOCUS

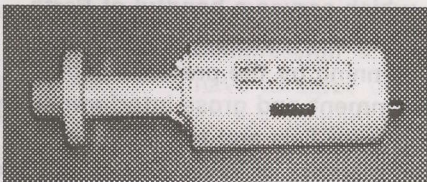

Our WP4U Prime Focus LNBF will allow one IRD to switch between RABS and Optus Vision. This LNBF fits the Andrew feed clamp.

We also stock a complete range of KU Band OFFSET LNBFs

EMAIL  experts@uq.net.au

Order Hotline  +07 3252 2947

Fax +07 3252 8541

Optus and their version of RABS, well - how do you earn the market back and the respect that may go with it?

Optus might "force" the receiver suppliers to bring in the 10,000 IRDs required to properly get RABS running. Would this be wise? If UEC and Matsushita (Panasonic) and Pace and SMS are all hung up on one-chippers, how much *real* pressure can Optus bring to bear?

Assume for discussion Optus threw caution to the winds and "demanded" the more expensive multi-chippers right now. What is the downside of that? Political, for one thing. Dr Mark Waggs at Optus has fought the IRD suppliers and the distributors, and through the distributors the installing dealers, each step of the way to implement RABS within the dollar limit of the \$750 RTIF voucher. Does Optus by forcing multi-chippers on 10,000 HACBSS homes *really* want to get crossways with the Australian government?

Back-up field service is another concern. A few thousand "forced-release" multi-chippers will quickly become orphans in a sea of single-chippers. Consumers are ignorant but not dumb; when word gets around they have been suckered into taking an "old technology multi-chipper" for their RABS conversion, they won't be pleased. Optus has made a big play about their "technology" and their claim "*it is several generations ahead of the Galaxy IRDs.*" Optus, by forcing multi-chippers into the field, will quickly be seen as betraying their own public commitment to the latest technology.

There is a time line here that Optus cannot control and it has to be worrying to them.

Meanwhile - at Foxtel

Buried in the busy week-that-was were hints from Foxtel they are planning their own DTH platform. Foxtel, for the new entrants, is 50% owned by News Corp and Telstra. An option to "buy in" is held by Kerry Packer's PBL and the final format for Foxtel is likely to end up being News Corp + Telstra + PBL.

Foxtel's cable TV progress has been significantly better than competitor Optus Vision; more than 300,000 cable subs to under 200,000. Foxtel and Optus both stopped rolling out new cable lines in 1997 and neither expects to resume cable rollout soon; if ever. Satellite is the obvious more cost effective way of reaching homes that are not presently in front of cable lines. Foxtel has been trialling digital (QAM format) cable TV delivery for more than a month and a small

quantity of digital IRDs for cable TV use are in selected homes. Foxtel believes cable TV will evolve into a digital platform although perhaps not for several years.

An executive of Foxtel admitted on May 24, "*Yes, we are looking at providing a DTH platform but it is not yet ready.*" Callers to Foxtel, ex-Galaxy subscribers, were told, "*Because we haven't rolled out any cable since October, the collapse of Galaxy has sped up our plans for satellite.*" How would Foxtel create a DTH service?

Their first preference might be having position on the same Optus B3 satellite as Austar (and Optus), and, on the same horizontal polarisation. That is a problem because B3 has only 7 suitable coverage horizontal transponders and if you add up the present and future requirements of Austar (2 now, 3 later), RABS (one now, a second later), and Optus (2 now, 3 later) you come to 5 now and 8 eventually. Foxtel might "buy their way in" but only if RABS was limited to one, Austar and Optus to two each. And because there are physical limits on how many programme channels can be crammed into a single transponder, RABS would be limited to some number fewer than 12 and Optus and Austar to some number smaller than 24. And so would Foxtel (in a 1 + 2 + 2 + 2 partitioning of Optus B3, horizontal).

So it is not a surprise to learn Foxtel is talking to another satellite operator, PanAmSat about Ku band PAS-8 for example. As we reported in SatFACTS for

May (see p. 14), PAS-8 has a quite attractive Australian Ku footprint with 49 dBw signals forecast to all major urban regions and dipping to 44 dBw in rural, central regions. That translates to dishes between .75 - 1m and 1.3 - 1.8m for the entire country.

PAS-8 is scheduled for launch in the last quarter of this year. If it moves up earlier, you can safely assume there is some pressure on them to do so from the likes of Foxtel. Foxtel's rollout of QAM digital cable service and their hope to create a QPSK DTH service are time-related. Equipment to make one happen supports equipment for the other and in fact cuts back

considerably on duplication of digital processing hardware. The uplink for DTH can easily be fed from their "master cable headend" where the QAM digital service is generated. And this kind of efficiency is important to the long term financial success of both services.

Quietly, Foxtel has placed an order with Pace for an unspecified "digital box." The initial quantity reported is 50,000 units and Foxtel suggests these are for their QAM cable rollout. Perhaps. *Perhaps not.*

Notes from Internet

"My wife has the shot gun out of the cupboard and is guarding the (Galaxy) satellite decoder with her life. I am just sitting in the corner whimpering, pondering what I am going to do without my pay TV!"

...

"Galaxy by satellite is the only pay TV in West Australia apart from Foxtel which serves a handful of Perth suburbs. Now as a result of poor planning by the previous Labour government and gross interference by Professor Fels and the ACCC a very large majority of West Australians are facing the prospect of having NO access to pay TV services."

- ✓ **Canberra and Western Australia:** Only served by Galaxy MDS, not available to Austar under original license.
- ✓ **Foxtel ends up on Optus B3:** There is a shortage of transponder space; for Foxtel to have room for 22 or fewer programme channels, Optus (DTH) and Austar will have to be limited to 22 each or fewer, and RABS to 11. There is only one viable solution that fits Austar + Foxtel + Optus onto B3; they agree to share programming across the board and to adopt the same (Irdeto) CA system. Don't hold your breath.
- ✓ **Foxtel ends up on PAS-2 now, PAS-8 later:** As reported on pages 29 and 32, here, Foxtel has been testing on PAS-2 Ku since June 4. If this proceeds, all ex-Galaxy dishes have to be repointed and probably equipped with a new CAM to accept a (unique to Foxtel) smart card. Don't read too much into the present testing; it could be nothing more than a flexing of muscle by Foxtel to put pressure on Optus.
- ✓ **Austar programme package changing:** Now carrying some channels from Foxtel and Optus, Austar plans more additions which will be "tiered" making individual subscriber selections more complex and requiring subscriber by subscriber interface for each of their 210,000 customers; not a small job.

The difference between a QAM box for cable and a QPSK box for satellite is small (see SF#44, p. 11) if addressed at the point of manufacture. It would not be a major challenge to "mix and match" the initial 50,000 unit order in both QAM and QPSK formats for use in Australia as the market dictated. One-chippers? Very probably yes.

If Foxtel goes ahead with a PAS-8 Ku band service, it will create almost exactly the *opposite* situation ACCC's Professor Alan Fels claims he wants. Fels told interviewers on May 24th, "*The failure of Galaxy may not turn out to be a mistake. I envision the day when Australian (pay TV) consumers will have a switch in their home and be able to select between Optus and Foxtel with a single set-top box.*"

Is that possible? In theory, yes. If Foxtel and Optus both used the same satellite, the same polarisation and most important of all - the same conditional access (addressing) system. Or, if both Optus and Foxtel through their cable lines uses the same QAM and CA systems.

Foxtel is not licensed for Irdeto and just as Galaxy was reluctant to allow Optus into the "Irdeto club" for DTH, you can be certain neither Austar nor Optus are about to allow Foxtel into the Irdeto club now, cheaply. And that presumes Foxtel would like into Irdeto. In fact, Foxtel has corporate ties with NDC, the Murdoch controlled competitive-to-Irdeto CA firm that has their own encryption and addressing technology.

So what is the likely format for Foxtel on PAS-8?

A second dish for those who might wish the Alan Fels ideal world of "at-the-push-of-a-button" choice in programming. And a second LNBF, and a second set-top IRD. *Not quite Fels' concept.*

In fact, from Galaxy as the only urban satellite operator and Austar as the only rural DTH provider, we move to Foxtel and Optus going head to head with home dish systems. And what many see as a terribly expensive competitive war - a replay of the terrestrial cable wars fought street by street during the great cable wiring explosion of 1996 and 1997.

The "Real" Time Line

RABS: Could happen with token delivery of IRDs through August, more likely to be "drip fed" to save face at Optus until September or October when the single

chippers are available. There are unspoken dangers here; the front running UEC 642 may have a dangerous power supply design (correctable) and the corporate stability of UEC is increasingly in question. (5)

Austar: Idealists might want to see Austar and Optus rolled into one, but what would that accomplish if Foxtel does launch their own PAS-8 based service? Actually, if Optus and Austar combined satellite forces they could get by with 4 or even 3 transponders total between them. And that *might* provide enough space for Foxtel to come back to B3.

ex-Galaxy DTH Subscribers: Under the illusion Foxtel is coming to rescue them. Maybe, but not without a price. If Foxtel is unable to pressure Optus into allowing them onto B3, 55,000 ex-Galaxy dishes will have to be repointed to PAS-2 as well as reworked to accept a new conditional access module. And that would be only temporary - an "interim" service until Foxtel was able to move to PAS-8 (early 1999) or come back for a second bite on Optus B3. Foxtel might get into the "Irdeto Club" but lacking B3, they won't be using an Australian satellite anymore. Is this GWN all over again?

Foxtel: We should not believe everything that is being "leaked" about their plans for a PAS-8 based DTH service. If Fels has his way, there would be five pay-TV transponders on Optus B3 "shared" between Austar, Foxtel and Optus. This could support a universe of nearly 60 programme channels given today's compression technology but all of the players would have to agree on a single compression and conditional access technology. That Foxtel would ever agree to using a non-NDC format for encoding stretches the limits of credibility. Still, this is where the government "pressure" is being applied.

Optus DTH: First they need transponder space, next they need IRDs. As their parent owns the satellite, the transponder space challenge seems doable if difficult. As for IRDs - well, 1999 seems like a good year and March 1 seems like a good target date.

5/ SatFACTS tests of a UEC 642 suggest a dangerous region in the power supply which may not pass Australian (consumer) safety testing; p. 18 here.

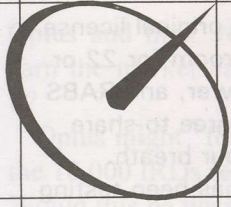

SATECH

Satellite Communication Technology Pty. Ltd.

Introducing

THE WINNING COMBINATION

NEW
with
Teletext



Phoenix 222

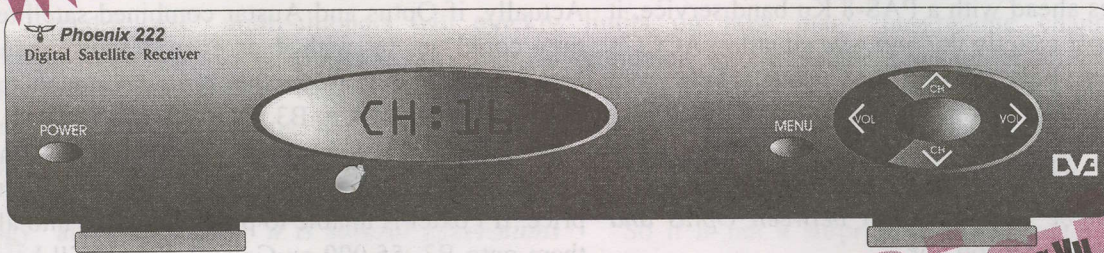

Phoenix 222 features

- Super sensitive tuner
- 1500 TV Channels
- 1370 Radio Channels
- 50 Satellites
- Auto installation
- Teletext
- On screen signal strength meter
- C + KU Band
- Auto Channel Search
- 0/12 volt Switch
- 4.3 16.9 Aspect with Pan and Scan
- Full Software Controlled TV Modulator with Channel Selection PAL D/K B/G I
- Upgraded Software down loadable from Internet via RS232C

Digital

- Power Vu
- DVB
- Teletext on TV5

No. 1
Choice

PALCOM

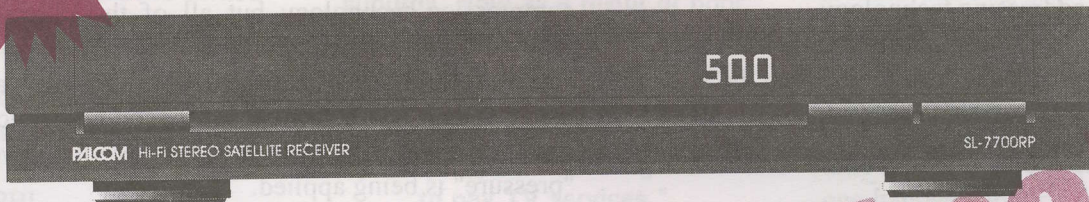

PALCOM SL-7700RP features

- Dual Axis
- Positioner
- Low Threshold
- Auto Focus
- Inclined Orbit Tracking

Analog
Palcom SL7700RP



Sole distributor for Phoenix Worldwide



SATECH

Satellite Communication Technology Pty. Ltd.

6/477 Warrigal Road Moorabbin East Victoria Australia 3189 Ph: 613 9553 3399 Fax: 613 9553 3393

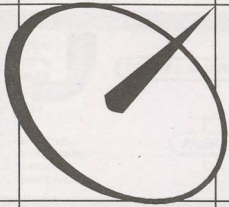

SATECH

Satellite Communication Technology Pty. Ltd.

One Stop Shop
for the
Satellite Technician
Cables

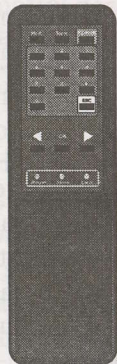

SuperJack EZ-2000 Satellite Positioner

- 32 Memories Positioner
- Remote Control
- Ideal positioner to use with digital receivers
- Compact design
- High position count
- Reed sensor, optical sensor or Hall effect sensor.

connectors

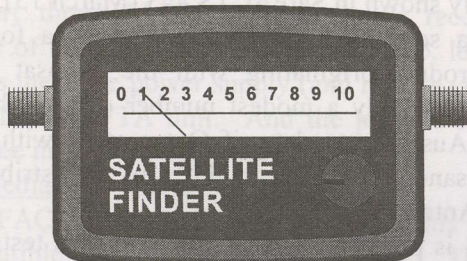

Satellite Finder

- With tone
- High sensitivity
- Makes finding Satellites easy
- Illuminated display
- Very low cost
- Guaranteed

dishes

splitters



Paraclipse[®] HIGH PERFORMANCE ANTENNAS

**SATECH your No.1 Paraclipse distributor
for the complete Paraclipse range**

See us for best prices

Paraclipse Dishes

- Exceptional strength and wind resistance
- Accurate reception

receivers

tools

All products available through the following SATECH Distributors:-

Southern Satellite - South Australia -Tel: 618 377 0955

Norsat - Western Australia -Tel: 618 9451 8300

Network Satellite Services - NSW -Tel: 612 9687 9903

Bay Satellite - NZ -Tel: 64 6 843 5296

Satech - Victoria -Tel: 613 9553 3399

DIGITAL IRD UPDATE 98-2

IRDs built in Asia are increasingly under pressure to sell well, *fast*, or get out of the market. With the catastrophic drop in Asian economies, major firms with names you would quickly recognise (such as Hyundai) have been told by their governments to *"cut out the fat, trim away any waste, and dump production facilities and products that do not measure up to present day profitability."* Korea is a prime example of what is happening.

Major Korean firms, called "chaebols," depend upon government guaranteed loans or outright gifts to create modern manufacturing facilities. When the Korean currency sank in value half way through 1997, the International Monetary Fund (IMF) came calling on the Korean government. *"Too much money is being wasted on ventures with limited chances of financial success. If you wish the IMF to continue to provide funds to Korea, clean up your act."* Translation? Firms producing products which were not creating instant profits were told to cancel the products or lose government support; chapter two of the IMF telling the Korean government to shape up or lose support.

Hyundai, Samsung and other brand names have until 1999 to get their "debt-equity ratios" back in line. This means reduce debt and that translates to cancellation of products and production lines which are not *currently* profitable. Today we have Korean chaebols disposing of production facilities and selling off product lines to unrelated firms. Caught in the middle of this national calamity are satellite IRDs produced by firms we quickly recognise. It is not only that Hyundai closed down the production line for HSS-100C units at the end of March but rather that products such as this IRD will

now often be reborn under a different name in the hands of a non-chaebol business firm. The risk here for buyers should be obvious. Whereas Hyundai or Samsung were mandated by corporate policy and pride to support their products in the field, no matter what the cost, new firms taking over these product lines are not likely to have either the finances or the corporate mandate to backup the products with the same integrity.

Into this very fluid situation we have the emergence of not only the same products under new names but new products under new names. More often than not, brand names will vary while products will be essentially the same. It is now possible to order as few as 100 IRDs and have your (selected by you) name on the product. Exclusivity of *design* for a geographic region (such as Australia) only comes with major buying power - and 100 units is not major anything.

Caveat emptor (1) should be your watch word.

UEC 642 Tests

As originally shown in SatFACTS #43 (March 15), the Optus Aurora selected UEC 642 receiver is a fourth generation product originating with the Panasat 520 design. Although only a modest number of 642s have appeared in Australia to date, if Optus stays with the product thousands more are on the way to distributor Nationwide Antennas.

SatFACTS is presently conducting extensive tests on the 642 and there are some bothersome but certainly correctable flaws in the early release units. One is safety oriented, as shown below. A small metallic object, such as a paper clip, can easily slide down through ventilation slots and into the IRD innards. In the top slot position illustrated, the paper clip ends up resting inside of the

Parallel receiver (PC board) inside of Phoenix MPEG-2 IRD turns digital into hybrid (left); a look at the new breed of "hybrids" in July SatFACTS. UEC 642 could have dangerous power supply fault (right; see text).

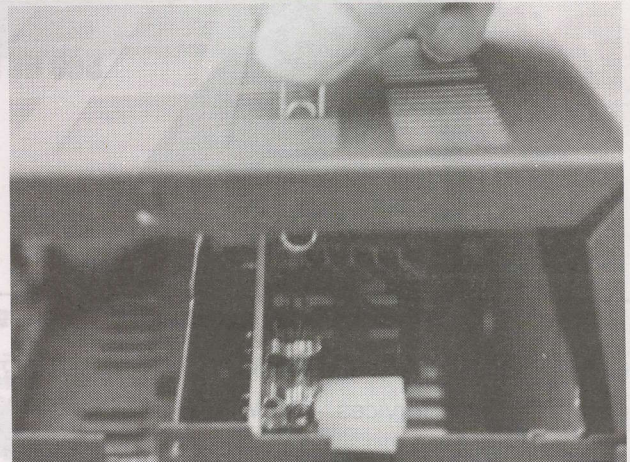
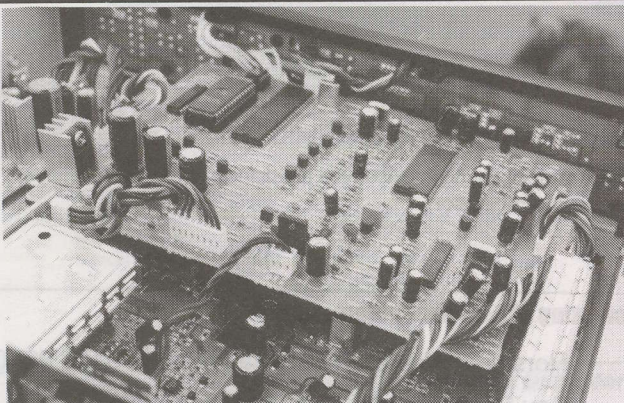

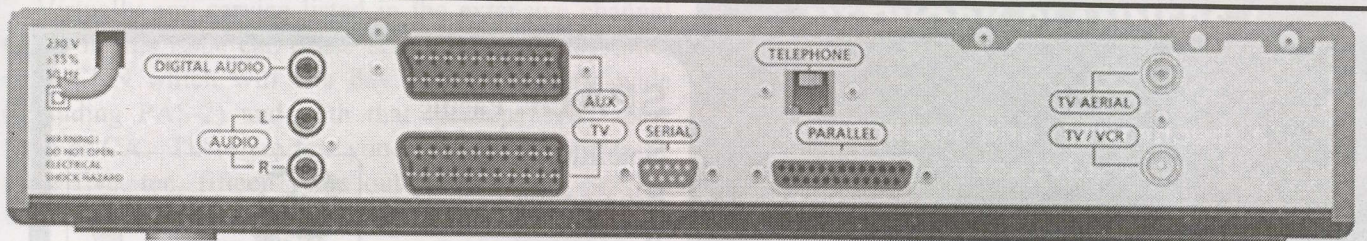

Not in our back yard. Nokia 9800 S Multiaccess is European-only IRD equipped with Viaccess plus common interface (PCMCIA) allowing use with a variety of conditional access platforms. The remote control design (right) is described as "unique" and was created for both "right and left handed users."

unshielded 230 VAC (mains) power supply parts. Given all of the "wrong" circumstances, this could result in a short and possibly a fire. Easily corrected (close off the slots over the power supply, cover up the power supply) before the Australian safety people get their hands on it.

A second problem is the Alps (brand) UHF modulator. In a word, it has a "dirty" output with undesired frequencies (beats) appearing in various portions of the UHF band. Again, correctable by UEC. We'll have an extensive 642 report in July.

Analogue - Digital Hybrids

They are coming to a distributor near you; *soon*. The Phoenix brand (from SaTech) version places a state of the art threshold extension analogue receiver board inside of the 222 digital IRD case (photo, left) where it shares the same power supply (and remote control) with the MPEG-2 FTA unit. And the price is right as you will see in our July scheduled report.

D7 MediaStar Update

SatFACTS for March (#43) reviewed this NTSC/PAL compatible IRD and gave it high marks. The software version at the time was 2.050 while the current version being shipped is the 2.09 and 2.10. The differences? 2.09 is for PAL markets with an output in PAL. If you tune in an NTSC service (such as PowerVu's BBC World) the video comes out as PAL at 60 hertz (nominal PAL is 50 hertz). Push "view-mute-view" on the remote and the video instantly changes to NTSC 3.58 (which is the broadcast format for BBC World). 2.10 is for NTSC markets with all NTSC outputted at 3.58 while PAL comes out as PAL-50 hertz (as it should be). The pricing has dropped significantly as well with a major price break for a master carton of 5 IRDs. An updated review in July.

Nokia's Latest - Not For Us

Want to be the first in your area to have a "single-chipper" IRD? The Nokia 9800 S is out in small quantities and if you do some digging in Europe, you might find one.

The major changes: Fully DVB compliant from 1 to 42 MS/s equipped with 2 Mbyte of RAM memory (up from 1), 2 Mbyte of Flash Memory (up from 1), 4 Mbyte of SDRAM memory (up from none - used for improved graphics on video) and a 32bit RISC processor (was

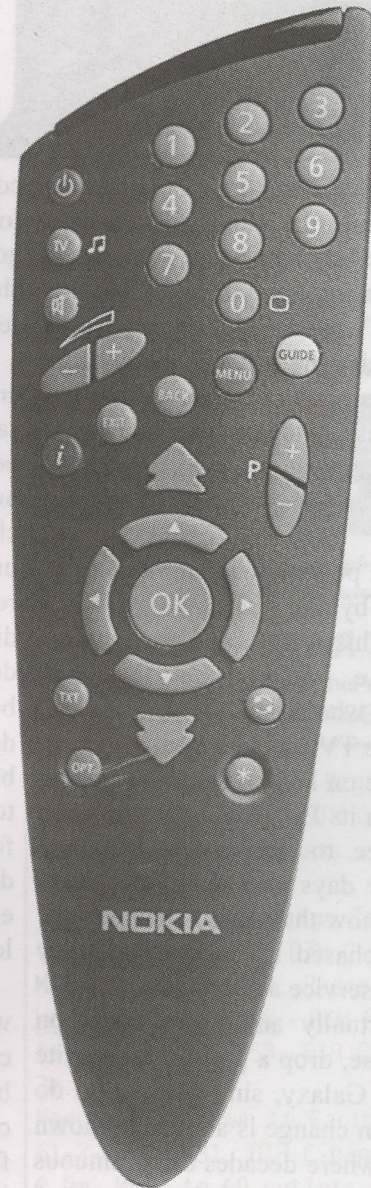

Motorola 68340, 16 MHz processor). Also added - an RCA output for digital audio (SPDIF), a PCMCIA Common Interface which if acquired in the "right" market is Irdeto capable. It is lower in power consumption (35w vs. 40) and draws only 3 watts on standby.

They say it is "plug and play" designed, can be software upgraded (through Internet) with a home PC download and features totally new on screen graphics with 256 colours. The new "ergonomic" remote control (shown) is for left or right handed people.

If Nokia put a fraction of their design skills to work to create a better environment for distributors and dealers to work with the firm, they would be unbeatable. Alas, the best product in the world is quite useless when the firm that makes it won't communicate with or support you as a dealer.

New At Skandia

Consumer friendly features including allowing the viewer to call up the full memory channel list as an overlay on top of the video being watched is one of the new tricks of the Humax F1 available for the first time through Skandia this month. By eliminating the need to leave the watched-video and going to the menu to change a channel, and, adding "last channel viewed" for instant return makes viewing more enjoyable. For dealers, pricing "like a Hyundai" will be enjoyable.

1/ Caveat emptor. *Buyer beware.*

a technical and marketing
advisory

memo

to the membership from your
industry trade association

SPACE Pacific

Satellite
Programme
Access
Committee



A trade association for users, designers,
installers, sellers of private satellite-direct
systems in the Pacific Ocean & Asia Regions

The shut down of Australis/Galaxy on Optus B3 has fired up lively debate within the ranks of satellite watching Internet users. As reported extensively elsewhere in this issue, almost everything connected with the Australian pay TV and conditional access (HACBSS) operations is under the microscope and the public debate raises questions concerning viewer rights.

What is the liability, what is the legal responsibility (if any) attaching to the dealer who sells a home dish system when a much desired service simply goes off the air?

The French CFI service, a powerhouse on Palapa C2, was replaced late in May by the "competitive" TV5 service; also from France. This is not quite the same as totally losing a service (i.e., Galaxy) but there are certainly viewers out there who found CFI more of a reason to own a dish than the TV5 replacement.

The Filipino GMA service on Palapa C2 also selected the end of May to shut down its Palapa C2 service. Here there is no immediate free to air replacement and SPACE telephones rang for days with worried dealers on the other end concerned how they could "make it up" to consumers who had purchased DTH systems solely on the strength of the GMA service availability.

The reality is that virtually any programmer on satellite can change its course, drop a particular satellite feed or as is the case with Galaxy, simply cease to do business. This sort of sudden change is almost unknown in the terrestrial TV world where decades of continuous service is the norm. This "here today - gone tomorrow" flavour of DTH is distasteful and difficult to explain to a

consumer who awakens one morning to find their sole (or primary) reason to have purchased a DTH system gone from their home. Obviously, each time a service shuts down or moves to a new satellite which is out of reach to you, home satellite TV gets another black eye.

Consumer questions are hard to answer after the fact and perhaps as you explain the merits of owning a satellite dish system to a prospect it would serve your best interests to throw in a few statements explaining the uncertain future of *any* specific service. But it is a challenge to explain that the sole reason for their dish purchase (GMA as an example, for which the only replacement is KIBC on As2, digital) could in fact disappear with very little or no warning at any time. If a dealer illustrates his point too well, the sale could easily be killed. On the other hand, consider the plight of the dealer who called SPACE the day GMA quit broadcasting to seek reassurance their absence was only temporary. He had, in fact, installed a home dish system for consumer based on the availability of GMA only five days prior to their shut down. The consumer paid, in effect, \$400 a day for GMA's 5 days of service before losing it.

This dealer finally decided his own reputation was worth more than holding onto the consumer's recently cashed cheque payment and the consumer got the money back. The dealer took back his system and while losing a customer earned heaps of praise for his attitude. He figures it will pay off long term in his region because he is in home DTH system sales and service for the long haul.

MEMBERSHIP IN SPACE

Membership in SPACE Pacific is open to any individual or firm involved in the "satellite-direct" world in the Pacific and Asia regions. There are four levels of membership covering "Individuals," the "Installer/Dealer," the "Cable/SMATV Operator," and the "Importer/Distributor/Programmer."

All levels receive periodic programme and equipment access updates from SPACE, significant discounts on goods and services from many member firms, and major discounts while attending the annual SPRSCS (industry trade show) held annually in New Zealand. Members also participate in policy creation forums, have correspondence training courses available. To find out more, contact (fax) 64-9-406-1083 or use information request card, page 34, this issue of

SatFACTS. Page space within SatFACTS is donated each month to the trade association without cost by the publisher.

Virtually any service listed in the extensive channel tables in this issue can cease broadcasting at any time; even CNN which will one day go digital world-wide (including PAS-2) and with that, perhaps even some form of CA. There are few you can depend upon to be there five, ten, fifteen years out on the same satellite with the same power level to your area. Actually it is worse than that. *There are none.* Even EWTN could (along with the balance of the California Bouquet) get bumped from PAS-2 to PAS-8 within 12 months and with that change take a nose dive in signal level for many locations.

The reality is simply this. What you see today is what you get. *Today.* Anything you "promise" tomorrow is at some risk of being gone. The mechanics of satellite delivery are reinventing themselves currently in an 18 month cycle. The best equipment and best techniques today will be history by January 1, 2000. With new technology will come changes in programme channels and service levels. With new satellites will come new opportunities for existing programmers to move around (as GMA did from Palapa C2 to Agila 2), as well as new programmers to replace old favourites (National Geographic replacing NBC Asia is an example - July 1). Couple this with financial failures (Galaxy) and technical failures (the newly available Moscow commercial channel NTV on 122E will within 18 months become virtually useless simply because the satellite will peter out) - and you have a roller coaster ride of reception changes.

So as tempting as it may be to build DTH system sales around specific programming from a specific service, it is far safer to sell "the bushel basket" rather than the individual apples. There are exceptions. The multitude of Chinese services now available (As2, PAS-2) should provide "safety in volume" simply because the odds are that if the customer is buying a dish to have access to Mandarin programming, in the nearly 20 now available there is a margin of probable stability for you as a dealer. There is another form of "safety" within the European Bouquet because the programmers are public broadcasting organisations built around bureaucratic forms. It is far more likely that Deutsche Welle or NHK will still survive ten years from now in a suitable form than say TVSN or even CMT.

The final "safety net" is the sheer growth in number of available satellite services. In just four years we have grown from 11 C-band programme services available between 180E and 100E to more than 150 and that number will double over the next four years. All of this effects the way you do business, how you position your "service" as a competitor for consumer dollars and the way you draw your line of "responsibility" in the sand.

The challenges to stay current, and out of fiscal and legal trouble, will grow increasingly more complex for as long as the satellite industry continues to grow rapidly. But you can be sure it will never be dull!

NETWORK PLANNERS / OPERATORS

Are you looking for qualified TVRO/ARO/DRO system installers within the region from Tahiti to Western Australia? SPACE Pacific can help.

SPACE Pacific Installer/Dealer and Retransmission level members are the ideal contractor source for one off or large project C or Ku band installations. Many members are "SPACE Certified" from the Mark Long digital and advanced technician courses, fully equipped and qualified to help you.

If you have a satellite installation project that requires skilled, experienced contractor help anywhere in the Pacific, contact SPACE Pacific for assistance.

SPACE Pacific Ltd.

tel 64-9-406-0651 ■ fax 64-9-406-1083

Co-operative skills for the challenges of the 21st century



STAR PERFORMERS

This month's featured
SPACE Pacific Installers

Melbourne, Victoria ■ Digitalsat Communications.
tel 61-3-9306-4167. DTH C-band to 4.5m, Ku to 3m. SMATV to 50 outlets. *SPACE Technician Certified.*

Tauranga, NZ ■ Tauranga Television Services Ltd.
tel 64-7-5440-854. DTH C-band to 4.5m, Ku to 2m. MATV to 40 outlets. Radio Technicians Cert.

West Wollsend, NSW ■ DKM Satellite TV Services.
tel 61-2-4953-2353. DTH C-band to 4m, Ku-band to 3m.

Newra, NSW ■ Down to Earth Antenna Service. tel 61-2-4421-3431. DTH C-band to 1.8m, Ku-band to 0.9m. MATV to 60 outlets. Telecom Australia Technial Officer.

Albury, NSW ■ John's Electronics. tel 61-2-6041-3388. DTH C-band to 4m, Ku-band to 3m. SMATV to 55 outlets. Austar Approved Installer.

Takaka, NZ ■ Golden Bay Services, Ltd. tel 64-3-5258-066. DTH C-band to 3m, Ku-band to 3m. SMATV to 15 outlets. Trade Certified Radio/TV.

SPACE Installer/Dealer Members: Have you completed the questionnaire form appearing on page 29 of Teck Notes Vol. 4, No. 1? To be listed here, do so today!

The CABLE Connection

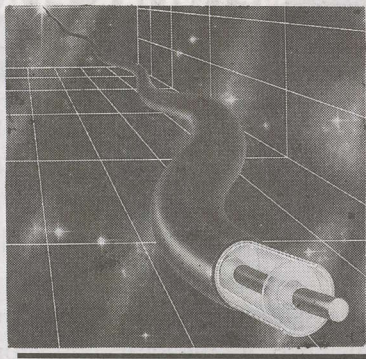

Loose Connections

A major problem with cable that interconnects two points is the connectors we are forced to use to complete the circuit. RG-6 series cable, the most commonly employed format between an LNB(F) and satellite receiver, works best with "F" series fittings. The F-fitting originated in America in 1951 as a quick application tool for the first cable television systems being installed there. The strongest design feature of the F-fitting: It uses the actual (RG-6) cable centre conductor directly without some type of "pin" that attaches over the centre conductor. Here is why that is a plus.

Any connector is an extension to a piece of 75 (or 50) ohm transmission line. The way transmission lines function is for their characteristic "impedance" to be uniform from end to end. If the impedance of the line is disturbed, an electrical "bump" appears on the line. This bump distorts the flow of radio frequency energy creating impedance "discontinuities" at the point of the bump. A discontinuity increases cable losses and can damage portions of the radio frequency spectrum passing through the bump by accentuating or attenuating selected frequencies within the spectrum being passed.

It follows that a 75 ohm impedance cable requires a 75 ohm impedance connector. As the best connector is no connector, any connection device that leaves the original physical size, shape and continuity of the cable alone is preferable to a connector that sticks foreign pieces of metal into the line. The F-fitting comes quite close to satisfying this requirement largely because the actual

When two "F" connectors are joined together, the "joiner" becomes a short section of 75 ohm transmission line.

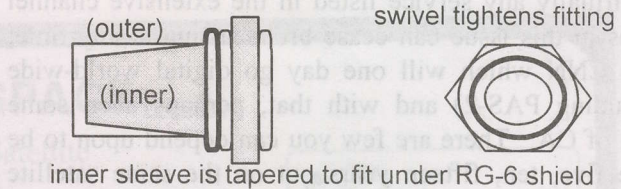
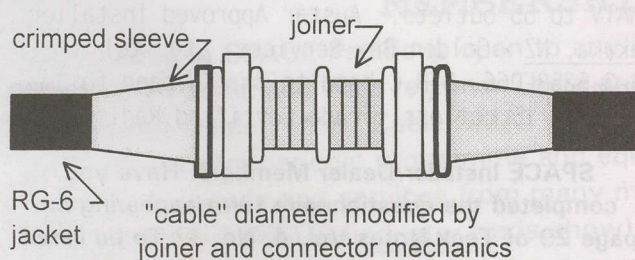

The "F" connector is about as simple and electrically "pure" as any connector ever devised. Alas, it is far from perfect and often mishandled during installation.

centre conductor for the cable is left untouched. No foreign object (such as a pin or sleeve that slides over the copper or copper coated centre conductor) intrudes into the cable line.

The downside of the F-fitting is the manner in which the "other half" of the electrical circuit is handled by the connector. The "shield" (or shields) in the RG-6 cable can be thought of as the "return" or balancing side of the circuit. The inner sleeve on the F-fitting is designed to slide inside of the cable shield where its outer surface makes physical contact with the inner surface of the shield. The outer sleeve is closed by the press-fit of the crimping tool. If the RG-6 cable has *two* or more shield segments (such as Quad Shield cable), the F-fitting sleeve slides over the *top* of the inner most shield layer (typically a paper-foil wrap adhering to the insulation material) but *under* the metallic webbing that makes up the outer shield layer.

It may surprise you to learn that for every variation in RG-6 cable there is but *one* purpose designed F-fitting. There is no such thing as a "universal" F-fitting that works with *all* of the many design variations of RG-6 cable. Using an F-fitting created to work with RG-6 that has only a single braid (webbing) shield and no foil wrap shielding for RG-6 that has one or two layers of foil wrap and one, two or three layers of braided webbing shield is almost as bad as trying to directly splice two sections of cable together with a soldering iron and plastic tape. If the F-fitting does not "fit" the cable properly, by not sliding smoothly under (or over as each case may be) the braided webbing, you have not

In a MATV/SMATV system, higher frequencies will "leak" across a poor fitting with greater efficiency than lower frequencies.

loose fittings ...

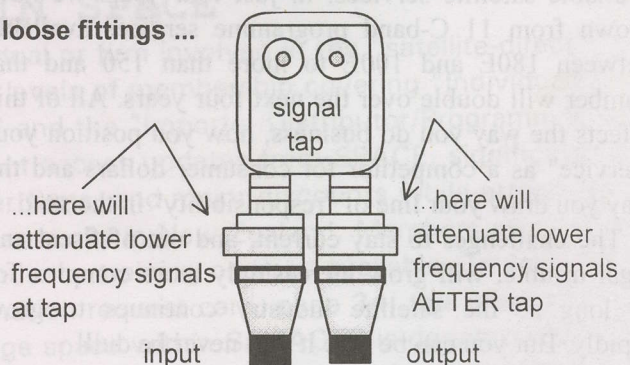

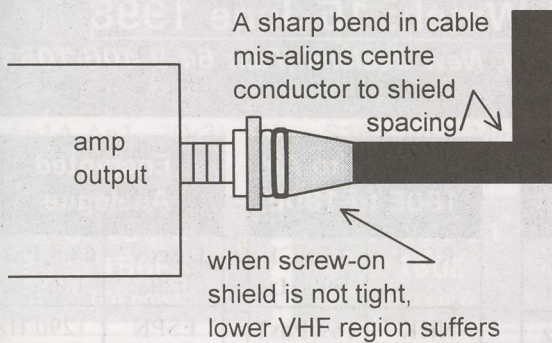

The most troublesome location for a loose fitting carrying 50-100 MHz signals is immediately after an amplifier.

only a "messy" connector but an impedance "bump" where the connector has been installed.

And for each design of F-fitting, there is one (and only one) installation (crimping) tool. There is no such thing as a universal "crimping tool" that is right for *all* formats of F-fittings.

F-connectors may look more or less alike, crimping tools may be attractive because they are 1/4th the price of others on offer. But if you have not chosen the *correct* fittings for the cable you are using, and do not select the one correct crimping tool for the fitting, you might as well resort to a soldering iron and plastic tape.

In larger cables (RG-11, and the many sizes of aluminium jacketed cable), the correct connector and the correct installation tool is mandatory. As is development of the correct skills to install the connectors. When you do it wrong, you have problems. Here are some common faults:

- 1) Improper fitting: Portions of the RF spectrum "disappear" along the way.
- 2) Loose or corroded centre conductor / fitting: Loss of *higher* frequency signals.
- 3) Loose outer shell of connector: Loss of *lower* frequency signals.

Don't assume anything with connectors!

In a 50 - 450 / 550/ 800 MHz distribution system, a poor shield connection will impact the low frequency end (near 50 MHz) most severely while a poor centre-pin (centre conductor) connection will usually degrade the high frequency end first.

if centre conductor is too short to mate properly with female fitting entire spectrum of frequencies suffer with higher frequency losses most severe



if screw on portion of fitting is loose, low frequency end is first to suffer and if power is being passed, it may stop here

Excess Stock clearance- Analogue receivers -

SR99 99channel analogue KU band satellite receiver with remote control, output on Ch 36- **\$40ea**

SR199 199channel analogue KU/C band satellite receiver with remote control, OSD, Output Ch 36- **\$90ea**

PSR3000 Pacific Satellite 250 channel receiver/positioner with remote control. Output on Ch 36- **\$190ea**

NEW releases-

Phoenix 222 Digital satellite receiver, MCPC & SCPC, 999 bouquets and 2900, channels, DVB and PowerVu compatible - **\$649ea**

Prosat P3500 Digital satellite receiver, MCPC & SCPC, 50 satellites, Satellite Az/EI calculator, DVB and PowerVu compatible - **\$639ea**

TVC3200 Hyundai digital QPSK satellite receiver with Irdeto CA & smart card slot- Available July 1998.

For full details see our home page- www.kristal.com.au

All prices in Australian dollars ex-store in Townsville Australia plus freight and sales tax if applicable.

KRISTAL
electronics

25 Cataract Ave,
RANGEWOOD QLD
4817. AUSTRALIA.

Tel. 61 (0)7 47888902 Fax. 61 (0)7 47888906
Mobile 0418778933

www.kristal.com.au kristal@ultra.net.au

When you need the last 0.1 dB to show that TV program that your customers want, you wish you have this IRD – the best to date...



System Specifications:

- Input frequency: 951 – 2150Mhz	- Auto FEC detection
- C/Ku Band	- NTSC/PAL AV output
- Super fast tuning and response	- Selectable Audio modes
- Channel listing and selection	- Channel deletion/editing
- 64 Transponder for 256 Channels	Signal strength display
- MCPC/SCPC 1 – 45Msym	- User friendly OSD

We are also dealer for:

Dish: Paracclipse Jonsa	Actuator: Venture
Analogue Receiver: Strong, Bensat	LNB/F: Chaparral, mit, Veccom
Digital Receiver: PowerCom, Phoenix	Video Transmitter: Veccom AVShare



NetSat (A.C.N. 076 156 262)

Tel: (612) 9687 9903 Fax: (612) 9687 9906

Mobile: 0411 525 106 e-mail: mleu@rivernet.com.au

SatFACTS Pacific/Asian Region Orbit Watch: 15 June 1998

Copyright 1998: SatFACTS, PO Box 330, Mangonui, Far North, New Zealand (Fax: 64-9-406-1083)

Analogue Free-to-Air 57E to 80E	
DD1	55E/2DT 1330/L
Sun Music	57E/703 1395/R
RTNC	1352/R
Gemini	1220/R
AsiaNet	1170/R
WorldNet	1095/R
TVi	1025/R
Muslim	975/L
Tests	66E/704 1385/R
Mongolia	1135/L
Home TV	68.8/Pas4 Vt/1310
ABN	Hz/1365
BBC W	Vt/1286
Sony TV (Hindi)	Hz/1240
SAT-7	Hz/1218
Doordar.	Vt/1116
CNNI	Hz/1065
TNT/Cart.	Hz/1040
MTV Asia	Hz/965
ZJTV	76/Ap2R 1390/Vt
TVT	78.5/Th3 1280/Vt
Army TV	1390/Vt
MRTV	1460/Vt
Mynamar	1465/Hz
Tests	1500/Hz
RAJ-TV	1510/Vt
Unk.Asian	1570/Hz
Tests	1630/Hz
TK Rossija	80/Exprs. 1472/L
VTV4+	1275/L
ACT/TB3	1225/L

Anal. Free-to-Air 80E to 113E	
Russia 3	80/Exprs 1025/R
RTR I	90/S6 1475/R
Orbita I	1275/R
RTR II	1234/R
Orbita II	1215/R
VTV4	91.5/Me1 Hz/1440
RTM1	1270/Hz
Metro	93.5/In2b 987/Hz
National	1022/Vt
DD9	1080/Hz
DD.7 (T)	1070/Vt
DD.9(K)	1180/Vt
DD.1	1268/Vt
DD.	1310/Vt
DD.4	1388/Vt
ORT 1	96.5/S14 1475/R
Madagas-car ++	1325/R
Tv Azer.	1275/R
ERTU Egypt	100.4/As2 1508/Hz
TV Shopping	1490/Vt
Feeds/Iran	1470/Hz
Feeds #	1290/Vt
WorldNet	1265/Hz
CCTV4	1190/Hz
RTPi	1170/Vt
RTR	103/S21 1475/R
Vrk/Apt	1275/R
TVRI	108/B2R 1150/Hz
TPI	113/C2 967Vt
TV5	990/Hz

Polarisation?
/L is left hand circular, /R is right hand circular, /Vt is linear vertical, /Hz is linear horizontal.

Anal. Free-to-Air 113E to 148E	
Brunei, feeds	113/C2 1010/Vt
MTV Asia	1030/Hz
Herbalife (2100 HKT)	1070/Hz
TV Indosiar	1090/Vt
CNBC	1110/Hz
ANteve	1130/Vt
CNNI	1177/Vt
SCTV	1190/Hz
TV3	1250/Vt
ATV(7) Australia	1270/Hz
TVRI	1310/Hz
Gujarat +	1350/Hz
RCTI	1408/Vt
Moscow	122/As-G 1475/L
Test Card	128/Jc3 1070Vt
Test Card	1170/Hz
CETV SD	134/Ap1A 1330/Hz
CETV2	1250/Vt
CETV1	1170/Vt
CCTV7	138/Ap1 990/Hz
Orbita-I	140/S7 1475/R
ORT1	145/S16 1475/R
RTR Russia	1275/R
GMA	146/Ag2 1363/Hz
Test Card	148/Me2 1070/Hz

Worldstar Radio Sat
Asiastar 1 to 105E (12/98); downlink 1.451-1.492 (GHz). Audio channel capacity: 576 @ 16Kbit/s.

- Check for wildcard feeds

An. Free-to-Air 150E to 180E	
RCTI	150/C1 990/Hz
NHK	169/Pas2 1090/Vt
CNNI	1183/Hz
CNN Feeds	1155/Hz
Feeds #	1370/Vt
TV Shopping	1405/Hz
Feeds #	174/I802 984/R
Feeds #	973/R
Feeds (KBS)	177/I702 984/R
Feeds #	963/R
Feeds #	180/I701 1340/R
RFO	1309/L
Feeds #	1220/R
Feeds #	1175/R
Feeds #	1090/L
Feeds #	1020/L

PALAPA C1 150.5E

Tests	990Hz
Tests	1140Hz
Tests	1220Hz
Tests	1330Hz
Tests	1360Hz

C1 not recently reported

Encrypted Analogue	
Discov. India	68.8/Pas4 1365/Vt
ESPN	1290/Hz
HBO Asia (d) *	113/C2 1150/Hz

* No longer available DTH, only to cable TV headends (Taiwan, Philippines): B-MAC

NON MPEG-2 DIGITAL SERVICES

People's Net (GI 1.5)	113/C2 1220/Hz
RPN-9 (SA 1.5)	142/G2 1225/L
Fox/Prime (SA 1.5)	169/Pas2/ 1161/Vt
Filipino Channel (GI 1.5)	1314/Hz

Frequencies Given in these charts are in C and Ku band IF. To calculate C-band RF, take IF given and subtract from 5150; for Ku-band using 11.300 LNB add IF given to 11,300. i.e., 5150-1508 = 3642 while 1358 + 11,300 = 12,658. (Tks-Mad Greek)

June Alert

If you are within PAS-2 Ku Australia-Oceania-New Zealand beam coverage, try 12.716Hz (12.716 - 11.300 = 1416IF) and check for MPEG-2 signal with 25.773 and 1/2. This is a test and it could easily be over before you get onto it. If you see it, drop SF a line with your dish size and location mentioned in report. Other: Keep an eye on C2 Hz this month for new services. Australia? Watch 87.5E for new Chinastar 1 tests. Cakrawarta 1 S-band at 107E claimed to start tests June 1.

53.2 55 57 66 68.8 76 78.5 80 87.5 93.5 96.5 100.4 103 107 108 113 122 128
 S27 2DT 703 704 Ps4 Ap2 Th3 Ex2 (Cs1) Me1 In2B As2 S21 Ct1 B2R C2 As-G Jc3
 C C C C C C C C C C C C C S C C C C,Ku

134 138 (139) 140 145 146 148 151 152 156 160 161 (166) 169 174 177 180 148W
 Ap1A Ap1 (Or3) S7 S16 Ag2 Me2 C1 A3 B3 B1 Mb1 (Ps8) Ps2 801 702 701 Es4
 C C C,Ku C C C C C Ku Ku Ku C C,Ku C,Ku C C,Ku C Ku

**OPTUS B3
156E
(Ku only)**

Austar Mpeg2	1389/Hz
ABC WA	1358/Vt B-MAC
Imparja	1355/Vt B-MAC
Austar Mpeg2	1326/Hz
GWN (to Sept.)	1300/Vt B-MAC
Net 9, Sky	1233/Vt B-Mac
Optus Mpeg test	1264/Hz
BMAC	1230/Hz
School tv	1170/Vt
Aur. Test	1107/Vt
Imparja	1040/Hz B-MAC

Optus A3/152E(a)

ATN7png	1297/Vt
ATN7png	1430/Vt

a/occasional use

**Palapa C2 Ku
(seen South equator)/113E**

Test bars	11.148/Vt
-----------	-----------

**MeaSat 2
148E**

Tests	1070/Hz*
-------	----------

* Colour bars, audio 6.8;
C-band covers Aust, NZ

**OPTUS B1
160E
(Ku only)**

Data	1402/Hz
QSTV	1377/Hz B-MAC
SE ABC HACBSS	1370/Vt B-MAC
SE SBS HACBSS	1344/Vt B-MAC
NE SBS HACBSS	1339/Hz B-MAC
NE ABC HACBSS	1313/Hz B-MAC
Sky Channel	1296/Vt B-MAC
ABC Radio	1276/Hz (digital)
OmniCast	1270/Vt (FM/FM)
ABC feeds	1247/Hz Pal
Sky Nz (sport)	1245/Vt VidCrypt
Net 9 feeds	1220/Hz B-MAC
Sky Nz (Orange)	1218/Vt VidCrypt
Net 10	1182/Vt E-Pal
Net 9	1180/Hz E-Pal
Net 10 feeds	1155/Vt Pal
QTQ9	1145/Vt
Optus test	1124/Vt
NZ feeds	1105/Vt-#
7 Net	1086.Vt E-PAL
Aurora MPEG-2	1076/Hz (tests)
CAA air to ground	1009/Vt Nbfm

**PAS-2
169E
(C + Ku)**

CCTV	1433.5/Vt (Sa9223)
Feeds-#	1407/Hz
Value Ch.	1405/Vt
Discovery PowerVu	1374/Hz (Sa9223)
AB Asia, feeds-#	1335/Vt
ABS/CBN	1314/Hz (GI 1.5)
WCE-TV, feeds-#	1250/Vt
MPEG-2 PowerVu	1249/Hz (Sa9223)
CNN+ (1/2Tr)	1183/Hz
FoxSports	1160/Vt (SA 1.5)
Feeds-#	1150/Hz
Feeds-#	1120/Vt
NHK (digital)	1115/Hz
NHK anal.	1090/Vt
NBC Mux MPEG	1057Vt (Philips)
MPEG-2 PowerVu	1002/Vt
HonKong	
TCS Sing.	967/Hz

PAS-2 Ku

GWN	12.263V
MediNet	12.286V
Telstra Bendigo	12.300V
Napa TC	12.415V
MTV Asia (MPEG)	12.604V
ABC Interchge	12.629, 638, 646 /Vt
Foxtel	12.716H
Herblife	12.732H

**Intelsat 801
174E**

Feeds-#	963/R
Feeds-#	984/R

**Intelsat 702
177E**

Feeds-#	963/R
AFRTS (PowVu)	973/L
Feeds-# KBS	984/R
Space TV Sys (MPEG)	12.612H

**Intelsat 513
177W**

Feeds-#	963/R
Feeds-#	984/R

(513 Ku)

Service	RF Freq.
US Nets	10.980V
NBC	11.015V
Feeds	10.510V

Ku Services
Intelsat Ku band services shown here are boresighted to Japan and nearby Asia, have not been reported south of equator.

Wildcard Feeds
Unscheduled programme, event feeds are found on # marked transponders.

UPCOMING SATELLITE LAUNCHES

Sinosat 1 - "July"
JcSAT6 delayed to July 30
Orion to 139E; now October 1
AsiaSat 3R - March 1 (1999)

**Intelsat 701
180E(W)**

TVNZ	955/Dmv 3000
TVNZ	964/Dmv
TVNZ	972/Dmv
TVNZ	980/Dmv
TVNZ	988/Dmv
Occ Vid.	1,020**
TVNZ	1,030
RFO +	1055**
SPN	1,069
Feeds-#	1,090**
SCPC	1,126
SCPC	1,136
Vidip/(e)	1220-#
Feeds-#	1,254
NHK(e), NBC	1,270
TVNZ	1,293/e
RFOanal	1,309**
Feeds-#	1,340
10 Oz MCPC (PwRvu)	1,385
CNN USA(e)	1430

* RHC & LHC
** LHC only
e/ encryption

(701 Ku)

NHK	11.135H
CBS	11.475H
CNN	11.508H

SatFACTS Pacific/Asian MPEG-2 Digital Watch: 15 June 1998

Bird	Service	RF/IF & polarity	# Prog channels	FEC	Msym
1703/57E	Sky News	4187/963RHC	1	3/4	5(.632)
		4140/1010RHC	1	3/4	5(.632)
	CNBC	4018/1132LHC	1	3/4	6(.000)
1704/66E	TV5	4055/1095RHC	4	3/4	27(.500)
		Indian bouquet	4068/1082LHC	2(?)	1/2
PAS4/68.5E	ART/ BBC	3980/1170Hz	2	3/4	5(.632)
		TVSN + TFC+	3743/1407Hz	6	3/4
	CCTV	3716/1434 Hz	6	3/4	19(.850)
Ap2/76E	AXN	3600/1550Hz	8	7/8	28(.340)
	Reuters	3636/1514Hz	1	3/4	5(.632)
	TVB 8	3680/14701Hz	2+	3/4	13(.240)
	Plus 21 (Adult)	3787/1363Hz	1	3/4	6(.110)
	Disney	3880/1270Hz	2	5/6	28(.125)
Thaicm 3/78.5E	UTV	3920/1230Hz	6TV(#1)	3/4	26(.662)
	UTV/MCOT	3880/1270Hz	8TV(#2)	3/4	27(.500)
	Reuters Feeds	3636/1514Hz	1TV	3/4	5(.632)
	Thai 5 Bouquet	3600/1550Hz	8TV	3/4	26(.662)
Measat 1/91.5	India Bouquet	12284/12346Vt	10+TV?	7/8	30(.000)
As2/100.5E	Chinese tests	12.295Hz	1TV	2/3	6(.103)
		12.329Hz	1TV (BTV 1)	1/2	6(.930)
As2/100.5E	Laos TV	4143/1007Hz	1TV	2/3	2(.889)
	Euro. Bouquet	4000/1150Hz	6TV. 1r. (#3)	3/4	28(.125)
	Hubei /HBTv	3854/1296Hz	2	3/4	4(.418)
	Hunan TV/SRTC	3847/1303Hz	1	3/4	4(.418)
	GuandongGDTV	3840/1310Hz	1	3/4	4(.418)
	Inner Mongolia TV Zizhiqu	3828/1322 Hz	2	3/4	8(.397) (1-China) (2-Mongolia)
	APTV London	3800/1350Hz	1	3/4	5(.631)
	BBC Radio	3793/1357 Hz	?	?	?
	WTN Jerusalem/ London	3790/1360 Hz	1	3/4	5(.631)
	WTN London	3786/1364Hz	1	3/4	5(.631)
	WTN HK	3775/1375 Hz	1	3/4	5(.631)
	WTN Moscow	3770/1380Hz	1	3/4	5(.632)
	LiaoningTV/Svc2	3734/1416Hz	1	3/4	4(.418)
	Jiangxi /JXTV	3727/1423Hz	1	3/4	4(.418)
	Fujian /SETV	3720/1430Hz	1	3/4	4(.418)
	Quinghai TV Zenghou	3713/1437 Hz	1	3/4	4(.418)
	Henan TV Main	3706/1444Hz	1	3/4	4(.418)
As2/100.5E	Sky Racing	4020/1135Vt	3TV	1/2	18(.000)
	EMTV	4006/1144Vt	1TV, 2 radio	3/4	5(.632)
	Hallmark/KIBC	3940/1210Vt	2TV, 4 aux.	2/3	26(.655)
	STAR TV	3900/1250Vt	7TV (#4)	7/8	26(.850)
	Hei Long Jiang	3834/1316Vt	1TV	3/4	4(.418)
	JSTV	3827/1323Vt	1TV	3/4	4(.418)
	AHTV	3820/1330Vt	1TV	3/4	4(.418)
	Shaanxi/"QQQ"	3813/1337Vt	1, 1 Radio	3/4	4(.418)
	Guangxi GXTV	3806/1345Vt	1, 1 Radio	3/4	4(.418)
	Eastern TV Taiwan	3785/1365 Vt	5TV (#5)	3/4	18(.000)

Interoperable Receivers

unknown
unknown FTA (NE zone beam)
Virtually any FTA receiver
HS-100C, e3
e3
(MPEG-2, Iredeto) (some CA)
Virtually any FTA receiver
Nokia e3, probably others
Any SCPC capable receiver
PowerVu (CA likely)
unknown CA /V2160, A-2120
CA (receiver unknown)
Mostly CA
Mixed CA and FTA
Nokia e3, probably others
Nokia e3, probably others
Philips
HS100C, e3
Virtually any SCPC receiver
Any DVB receiver
Virtually any SCPC receiver
Virtually any SCPC receiver
Virtually any SCPC receiver
Virtually any SCPC + MCPC receiver
DMV, HS-100C, N163 /17X/2X
(Comstream ABR200/202)
DMV, HS-100C, N163/17X/ 2X
Mostly CA now
Virtually any SCPC receiver
Virtually any SCPC receiver
Virtually any SCPC receiver
Virtually any SCPC receiver
Virtually any SCPC receiver
Virtually any SCPC receiver
Virtually any SCPC receiver
Pace DVS-211 (CA)
(now) CA: PV9234
HS-100C (2.05), e3 (V5.0)
Now all CA (Pace DVS211)
Virtually any SCPC receiver
Virtually any SCPC receiver
Virtually any SCPC receiver
Virtually any SCPC receiver
Pv9223 (CA)

Remember to reload: When MCPC bouquets add new programme channels, you need to reload the bouquet to update your channel list and access the new programming.

Bird	Service	RF/IF & Polarity	# Prog. channels	FEC	Msym
(As2/100.5E)	Myawady TV	3766/1384Vt	1TV	7/8	5(.080)
#	Japan Tel (feeds)	3765/1385Hz	1TV	3/4	5(.632)
	STAR TV	3700/1450 Vt	8TV (#6)	3/4	28(.100)
C2/113E	Tests	11.500Hz	multiple TV	7/8	26(850)
	Star Indovision	3500/1650Hz 3580/1570Hz	20 TV (#7)	7/8	26(.850)
	Indovision	3460/1690Hz	6TV (#7A)	7/8	21(000)
	MegaTV	3780/1370Vt	5TV (#8)	3/4	27(.500)
Thaicom 1/120E	Thailand terres.	4120/1030Vt	6TV	2/3	27(.500)
	ITV Thailand	3946/1144Vt	1TV	3/4	6(000)
APIA/134E	AXN	4060/1090Vt	8	7/8	28(.340)
API/138E	Reuters	3732/1418Vt	1TV, data	3/4	5(.632)
	CNNI + Cartoon	3980/1170Vt	2+ TV	3/4	26(000)
Palapa C1/150.5	Indovision	4117/1033Hz	10TV	7/8	26(.850)
Optus B3 156E	Aurora Test	12.407Vt	4 TV, 4 radio	2/3	30(.000)
	OptusVision test	12.564 Hz	8TV (#9A)	3/4	29(.473)
	Austar	12.626Hz 12.689Hz	18 TV, 8 radio (#9B)	3/4	29(.473)
Optus B1 160E	Aurora (MPEG test)	12.377Hz	5+ TV	2/3	30(.000) [27(.500)]
PAS-2 169E	ABC Interchange	12.646 (.638, .629)Vt	1 TV (each)	3/4	6(.980)
	Telstra Bendigo	12.300Vt	3TV, 2 radio	1/2	10(.138)
(Inactive?)	Mediasat	12.286Vt	1TV	3/4	6(.610)
	GWN Perth	12.265Vt	2TV, radio	1/2	16(.200)
	Foxtel tests	12.716Hz	up to 6TV (#9C)	1/2	25(.773)
#	PAS-2 feeds	12.730Hz	2TV, 1 data	2/3	6(.620)
#	Hong Kong PowerVu	4148/1002 Vt	8TV (#12)	2/3	24(.430)
#	NBC Hong Kong	4093/1057Vt	7TV(#13)	3/4	29(.473)
	JET Singapore	3962/1188 Vt	2TV (1-Ntsc, 2-Pal)	1/2	13(.740)
	ESPN (USA)	3860/1290Vt	4TV, 2 control	7/8	26(.470)
	CCTV China PwrVu	3716.5/ 1433.5 Vt	5TV (#14)	3/4	19(.850)
	TCS Singapore	4183/967Hz	2TV(#15)	1/2	6(.620)
#	ITJ- J.Telecom	4.174/976 Hz	1 TV	3/4	5(.632)
	AAR-ART//RAI	4151/999 Hz	3TV(#16)	3/4	5(.632)
#	Feeds	4138/1012Hz	1TV	3/4	6(.620)
	NHK Joho	4035/1115Hz	5TV (#16A)	3/4	26(.470)
#	PAS-2 feeds	3940/1210 Hz	2TV(NTSC)	2/3	6(.620)
#	California PowerVu	3901/1249Hz	8TV (#17)	3/4	30(.800)
	Disney/Aust.	3804/1346Hz	1TV	5/6	21(.093)
	Discovery Singapore	3776/1374 Hz	7TV (#18)	3/4	21(.093)
	Satcom 1-6	3743/1407Hz	6TV	7/8	19(.465)
#	Unknown test	3718/1432 Hz	3TV	2/3	6(.620)
1702/177E	AFRTS	4177/973 LHC	8TV, 12 radio & data (#19)	3/4	28(.000)
(Taiwan feeds inactive?)	SPACE TV Systems	12.612/1312 Hz	13TV, 11 radio (#20)	3/4	26(.694)

Interoperable Receivers
HS-100C (PIDs now 1062/1063)
Virtually any FTA receiver
Pace DVS-211 (CA) + FTA.
Pace DVS-211 (CA)
Pace DVS-211 (CA)
Pace DVS-211 (FTA)
N2X/DVS-211(CA)
unknown
unknown
unknown
N163/17X/2X
(CNN clear) / unknown
same as 3580 C2
Irdeto CA - tests (UEC 642 with card)
FTA for testing only
DGT400 CA (when temporary FTA ends)
N163/17X/2X. Pv9223. HS-100C
Pv9223, Hs100C. e3
Pv9223/9234. (CA)
Pv9223, HS100C. e3 (some CA)
Pv9234 (CA)
FTA during temp. testing
Virtually any FTA receiver
Pv9223, HS-100C(*), N2X* (some FTA)
Virtually any FTA receiver
Pv9223 (CA)
Pv9223 (CA)
Pv9223, HS-100C, N163/17X/2X (FTA)
Virtually any FTA receiver
HS-100C
Virtually any FTA receiver
HS-100C. e3
1CA/D9234; 2-FTA HS-100C +
Virtually any FTA receiver
CA PV9223; FTA virtually any receiver (some with NTSC glitch)
Pv9223 (CA)
Pv9223, HS100C, N2X (occasionally Ch. 2 FTA)
Pv9223(CA)
e3
Pv9223 (CA)
XTCCDTV200 (All but 1 [#301] now CA)

#- Check for wildcard feeds

SatFACTS MPEG-2 Digital Watch: 15 June 1998 ♦ Support Data

Bird	Service	RF/IF & polar.	# Prog. Chs	FEC	Msym
1701/180E	TVNZ Gennet (feeds)	4195/955RHC	1TV(CA)	3/4	5(.632)
		4186/964	(BBC Gennet)		
		4178/972	1TV(CA)		
		4170/980	(APT/TV/Tokyo+)		
	Americas(radio)	4175/975LHC	3+ radio (?)	2/3	3(.680)
	TVNZ CRY	4120/1030RHC	1TV	3/4	5(.632)
	RFO-Canal +	4095/1055LHC	7TV, 5 rad.(#21)	3/4	27(.500)
	SPN Nauru	4081/1069RHC	1TV	3/4	4(.730)
	SPACE TV	3922/1228LHC	2TV (FTA)	7/8	21(.200)
	TVNZTL	3857/1293RHC	MTV Europe	3/4	5(.632)
	10 Australia	3765/1385RHC	6TV	7/8	29(.900)

Interoperable Receivers
DMV.. HS100C, N17X, 2X. e3 (for non CA channels when active: not all channels active all of the time).
Receiver unknown (CA)
(see TVNZ above)
MPEG-2, 2-CA, 3 FTA
HS-100C. e3
Unknown - reception not verified
HS100C. e3 (now CA)
Hs100C. e3, Pv9223 (4ch CA)

Bouquets: 1) Thailand UTV: (Now all CA); 2) Thailand UTV/MCOT: (Disney, TNT/Cartoons FTA; rest CA) 3) European Bouquet. (1) Deutsche Welle, (2) MCM, (3) RAI International, (4) RTVE, (5) TV5 Paris; Radio (1) DW#1 (stereo), (2) DW#2 & 3, (3) DW#4 & 5, (4) YLE (left) & RCI (right), (5) WRN & test, (6) REE, (7) RF#1, (8) RF#2, (9) RFI Music, (10) RNW, (11) RAI, (12) NN, (13) SRI; 4) STAR TV Hong Kong. (Now all CA); 5) Eastern TV Taiwan. Now all CA except occasional (5) RockTV; 6) STAR TV Hong Kong. Now all CA except (1) Sky Contributions, (2) ESPN Contributory; 7) Indovision. 20 channels operating at last report, all CA; 7A) Indonesian Bouquet: (6 terrestrial TV services FTA on DVS-211 receivers [transponder reaches South Pacific as well]; 8) MegaTV operating status unknown; 9A) Optus Vision tests, FTA as of 07-06-98 (temporarily): (1) Odyssey, (2) Movie 1, (3) Move Extra, (4) Movie Greats, (5) MTV, (6) Sky News, (7) AFL, (8) ESPN; 9B) Austar (temp FTA) (1) Fox Sports, (2) Showtime, (3) Encore, (4) TV1, (5) Arena, (6) Channel <v>, (7) Nickelodeon, (8) Discovery, (9) Fox Sports II, (10) Lifestyle, (11) Comedy Channel, (12) World Movies, (13) Announcements, (14) CMT, (15) TNT/Cartoon, (16) BBC World, (17) TVSN, (18) CNBC; Radio (CD stacker fed) - (1) Country, (2) Dance Techno, (3) Light Classical, (4) Top 100, (5) Environmental, (6) Cafe Jazz, (7) Radio Extra, (8) Classical Hits; 9C) Foxtel tests: (frequent changes; some FTA) - (1) UK TV, (2) Showtime, (3) Encore, (4) Hallmark [not same as As2 Hallmark], (5) TV1, (6) World Movies; 12) Hong Kong PowerVu. (1) CTN 1, (2) CTN II, (3) TVBI, (4) TNT/Cartoons [PAL], (5) Ad-hoc II [NTSC], (6) Ad-Hoc PAL (blue screen), (7) CTN III, (8) CTN IV; 13) NBC Hong Kong. (1) CNBC 625, (2) CNBC Mandarin A, (3) NBC Asia 625 (*), (4) NBC-J 525, (5) CNBC Mandarin B 525 (6) NBC "2", (7) Syndication 625 (* - to be National Geographic July 1); 14) CCTV China. (1) CCTV4, (2) CCTV3, (3) CCTV 9, (4) CCTV4, (5) CCTV5, (6) CCTV8, (7) CCTV tests; 15) TCS Singapore. (1) TCS Test, (2) TCS Default [repeats channel 1]; 16) SCPC3. (1) ad-hoc use, (2) AAR/ART, (3) RAI International; 16A) NHK World (1) NTSC Jap, (2) NTSC Eng, (3) PAL Jap, (4) PAL Eng, (5) NHK radio, (6) NHK Premium 17) California PowerVu. (1) CMT(NTSC), (2) Ad-Hoc 1 (3) ART (4) EWTN (NTSC) global Catholic radio, ch. 2, (5) BBC World (NTSC), (6) Bloomberg Financial (NTSC), (7) Golf Channel (NTSC), (8) ATUG Discovery (occ. FTA); 18) Discovery. Now all CA except occasional (2) Disc. default; 19) AFRTS. Up to 19 video, audio, data channels; non accessible (PowerVu CA); this is a very dangerous (Bootloader) place for D9223 receivers to be! 20) SPACE Systems (177E, Ku) is now believed to be off the air although Thai TV5 (loads as 301) and two North American adult channels reportedly continue. 21) RFO (feeds from France). (1) Canal + (Caledonia), (2) Canal + (Polynesia), (3) Saudi TV, (4) Abu Dhabi TV, (5) TOM1/RFO1, (6) TOM2/RFO2, (7) TOM3/World Cup Soccer, (8) Radio Abu Dhabi, (9) Ellibera FM, (10) Radio F1-stereo, (11) France Radio Contributions, (12) RFI France. (Acknowledgements: Stu McLeod, Paris C. David Leach)

MPEG-2 DVB RECEIVERS: [Data here is believed accurate; we assume no responsibility for errors in this volatile area!]

AV-COMM R3100. FTA, excellent sensitivity (reviewed SF May 15, 1998). Av-Comm Pty Ltd, tel + +61-2-9949-7417.
DMV/NTL 3000. Commercial receiver available in several software formats. Skandia Electronics Pty Ltd (tel 61-3-9819-2466)
Grundig (Gng) DTR1100 (badged Panasat 630, believed no longer in production). Av-Comm Pty Ltd (tel 61-2-9949-7417)
Hyundai-TV/Com. Ceased production of HSS-100 family of IRDs in March. Still in pipeline, model HSS-100B/G (for Pacific) and HSS-100C (for China). Versions in 2.25/2.26 region were good performers, version 5.0 had tuner sensitivity and other problems. Skandia (tel 61-3-9819-2466) has version 3.11 about which nothing is known; SATECH (tel 61-3-9553-3399) has version 2.26.
Hyundai TVC3200. Irdeto, European format. Kristal Electronics (61-7-4788-8902), available July.
MediaStar D7. Supplier preloaded software known channels, V. 2.09, 2.10 from Opac Pty Ltd. (61-2-9584-1233)
Nokia "d-box" (V1.7X) suitable for C-band use. Instructions, on-screen prompts may be in German. Be careful when buying this one!
Nokia 9200/9500/9600. There are too many Nokia versions to count. The original 9500S software version 1.63 was uniquely capable of going through a satellite and locating digital transponders and placing on the menu screen the Msym, FEC and operating frequency of every digital signal found whether FTA, CA, MCPC or SCPC. Sadly, that ability is gone with newer models. Current version software within 9200/9500/9600 model numbers is 5.0 or higher. Nokia refuses to support distributors in Asia or the Pacific and users are forced to locate and purchase product through European sources. The most helpful and knowledgeable Pacific region supplier for this product is AV-COMM Pty Ltd at tel 61-2-9949-7417. (See this listing, SatFACTS April 1998 and earlier for greater detail.)
PACE DVS-211. Officially available only through Sky (racing) Australia (Bob Pankhurst tel 61-2-9451-0888).
PACE DGT400. Original Galaxy IRD, now owned by Foxtel. For status (within Australia) call HOTLINE 1300-360818.
PACE DVR-500. Apparently no longer current except through NBC to cable, broadcast affiliates; basically DGT400, has CAM ability.
Panasat 520 (Pn520), 630 (Pn630), 635 no longer available; spares through UEC in South Africa (fax + +27-31-593-370)
Panasonic TU-DC10/TU-DS10. Scheduled for use in Optus RABS digital conversion; Antares Electronics tel + +61-7-3205-7574
Phoenix 222. FTA including PowerVu. Exceptional graphics, ease of use. Satech (61-3-9553-3399).
Power-Com. FTA including PowerVu, NTSC and PAL. NetSat (61-2-9687-9903)
PowerVu D9223, 9225, 9234. Scientific-Atlanta (Sydney) Tel 61-2-9452-3388; BaySat (tel 64-6-843-5296), Telsat (64-6-356-2749)
 Note: SA D9223 receivers are RISKY to use for enthusiast purposes because of susceptibility to software overwrite during "boot-loading" sequence. Model 9234 is currently distributed in Western Australia for GWN reception under "RTIF" subsidy programme, and for NHK Premium through SA as well as in PNG for EMTV "authorised" sites.
SK888. From Sun Moon Star (DigiSkan) through Skandia Electronics Pty Ltd. (tel 61-3-9819-2466)
UEC 642. Irdeto equipped for Australian RABS services, will also do pay-TV Irdeto services. Nationwide Antennas (61-7-3252-2947).
YURI HSS-100C. Rebadged Hyundai, software 2.27 which is Australian created mod from V2.26. Nationwide (61-7-3252-2947)

WITH THE OBSERVERS

Free to air access to the complete World Cup 98 series of matches is promised on the RFO digital bouquet Intelsat 180 (4095/1055 LHC, Msym 27.500 and FEC 3/4). These two "World Cup" channels will be the terrestrial France 2 and 3 services and may extend beyond the World Cup matches to include significant parts of their daily schedules as broadcast live in France. One of the bouquet channels will be "hot" when there is a single live match, the second will fire up when there are two simultaneous matches; testing began June 5th. Observer Robin Colquhoun also reports World Cup Soccer in digital MPEG-2 testing on Palapa C2 at 3770/1380 Hz. Many terrestrial commercial networks will be carrying the final matches; the RFO service, in particular, will start with the first events and stay with it to the end according to French sources. Other probable sources would include RTPi (analogue 3980/1170 Vt on As2) and RTVE (digital within European bouquet 4000/1150 Hz at Msym 28.125 and FEC 3/4).

Stu McLeod (Napier, NZ) found the RFO digital feed (I180 - see above) to load with the following service channels on his Hyundai HSS100C, version 2.25: (1) Canal + (Caledonia-CA), (2) Canal + (Polynesia-CA), (3) RFO 1, (4) France International (radio channel), (5) RFO 2, (6) Contributory Papar (radio channel), (7) Saudi TV, (8) Abu Dhabi TV, (9) Radio Abu Dhabi, (10) Ellibera FM (radio). David Leach (NSW) reports a change June 5 to: (1) Canal + (Caledonia), (2) Canal + (Polynesia), (3) Saudi TV-FTA, (4) Abu Dhabi TV -FTA, (5) TOM1-FTA/RFO1, (6) TOM2-FTA/RFO2, (7) TOM3-FTA/World Cup tests, (8) Radio Abu Dhabi, (9) Ellibera FM, (10) Radio F1-stereo, (11) France Radio Contributions, (12) RFI France.

David Leach (NSW) reports GMA's Agila 2 feed (3787/1363 Hz) is in P1 region on 4m size dish. Francis Kosmalki (Auckland) reports the signal "detectable but not even P1" on a 3.7m dish. The GMA service is somewhat unique because of fairly high English language content and importation of CBN (Christian Broadcasting Network) "700 Club" programming from USA. This leaves KIBC, part of the "Hallmark Bouquet" on As2 (3940/1210 Vt at Msym 26.665 and FEC 2/3) as the only available FTA Filipino service in the Pacific (and Asia - beyond reach of Agila 2).

Chinastar 1 has been launched with apparent success (31 May) and should be testing from 87.5E as soon as June 20th. This is a C-band bird with uncertain transponders on board,

AT PRESS DEADLINE

Foxtel has been testing on PAS-2 Ku, 12.716 horizontal with parameters of 25.773 and 1/2. Initially one video channel, then six with frequent changes, including no audio at times. Remember - this is a test situation and the uplink is an OB van parked outside of Foxtel studios in Sydney! (Oh yes - DGT400s work here.)

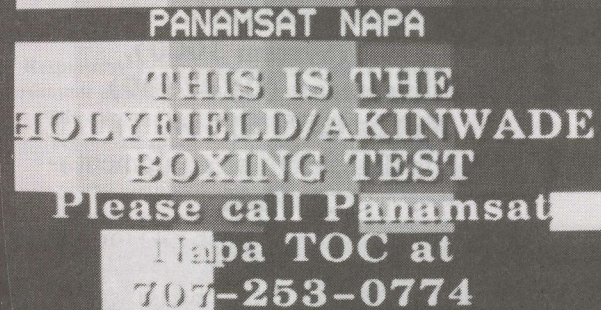

PANAMSAT NAPA
THIS IS THE
HOLYFIELD/AKINWADE
BOXING TEST
Please call Panamsat
Napa TOC at
707-253-0774

SPECIAL feeds for special purposes - especially sporting events - are often "shipped" on little used SCPC or small-bouquet MCPC channels found listed in our Digital Watch tables monthly. Look for the # symbol (new this month) to alert you where to check for special feeds.

and a tightly designed footprint that covers only China proper. Reports are solicited.

Star Movies has shut down on AsiaSat 1 on 4180 Vt, replaced with digital service on As2 (CA). Myanmar TV's analogue service on As1, 4140 Vt, has also shut down.

Observer **Robert Hepple** (Whakatane, NZ) reports SPN appears to be stronger now than it was originally and is now solid at his location on a 3m mesh dish equipped with CP400 feed and HSS100C receiver.

Sky NZ feeds from Australia can be found on 12.405 Vt on Optus B1 at irregular times.

On screen text messages began warning Star News (India) viewers on As2 (3740/1410 Vt) it would transfer to a digital feed May 25. The service went to digital June 6th and is believed to be on As1 3880Hz in (CA) bouquet (26.850, 7/8).

Observer Stu McLeod (Napier, NZ) and others report seeing PanAmSat Napa MCPC bouquet on 12.730 Hz operating in content parallel to PAS-2 C-band bouquet found on 3940/1210 Hz. The numbers are: Msym 6.620, FEC 2/3 with NAPS A2 test cards on Ch. 1 and 2 and Metromux (CA) service on Ch. 3; PAL format video (the C-band feed is in NTSC). Note this

WITH THE OBSERVERS: Reports of new programmers, changes in established programming sources are encouraged from readers throughout the Pacific and Asian regions. Information shared here is an important tool in our ever expanding satellite TV universe. Photos of yourself, your equipment or off-air photos taken from your TV screen are welcomed. TV screen photos: If PAL or SECAM, set camera to f3.5-f5 at 1/15th second with ASA 100 film; for NTSC, change shutter speed to 1/30th. Use no flash, set camera on tripod or hold steady. Alternately submit any VHS speed, format reception directly to SatFACTS and we will photograph for you. Deadline for July 15th issue: July 3 by mail (use form appearing page 34), or 5PM NZT July 4th if by fax to 64-9-406-1083.

Distribution centre of DVB MPEG-2 digital receivers for FREE-TO-AIR satellite TV programmes.

Wholesale & Retail Welcome

Consumer grade ---
**HYUNDAI (HSS-100C),
 NOKIA (DVB 9500S),
 PACE (DSR 200)**

Professional grade ---
**DMV (System 3000),
 Hirschmann (DVB7500)
 Philips (DVS 3950/11)**

Satellite IF distribution equipment --
GLOBAL.

Come and visit us if you pass by Hong Kong!

Hong Kong Satellite TV Ltd., Unit C, 7/F, Block 6, Tien Chu Centre, 74 Pak Tai St, Tokwawan, Kowloon, HONG KONG
 tel: (852)2736-8703
 fax: (852)2735-0583
 email: hkstv@netvigator.com

✓ YES, please send me info about _____ brand Company _____

Detail address: _____

_____ p'code _____

Tel: _____

Fax: _____

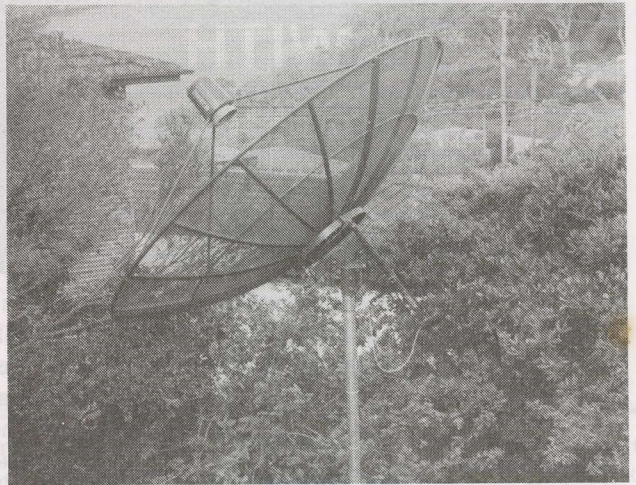

3m DISH atop 8m tower in (unnamed!) Sydney suburb - some people MUST have their satellite TV!
 (Photo courtesy Av-Comm Pty Ltd.)

service seems erratic in operation on 12.730 and may have been a short-term test to check out this transponder before Foxtel began their tests on 12.716Hz. McLeod also finds high symbol rate non-video data services on 12.566 and 12.600.

Planning for a possible Greek and Italian programming expansion into the Pacific is underway in Cairo. The contact is **Andrew Patton** who can be reached at (tel) ++20-2360-0520 or (fax) ++20-2349-0106 or email at andrew@aer.com.eg. He is Manager of International Marketing and Business Development for ART and is interested in hearing from those who would be a part of this expanded service.



MELBOURNE SATELLITES P/L

ACN 065 270 733
 Established 1992

Direct importers and suppliers of the following world renown products.

**KTI
 ORBITRON
 PATRIOT
 JONSA
 ANDREW**

**ECHOSTAR
 SCIENTIFIC ATLANTA
 NOKIA
 IKUSI
 DX**

**GARDINER
 CALIFORNIA AMPLIFIER
 MTI
 CHAPARRAL
 ADL**

Full range of cables, splitters and connectors.

Phone, fax or write for our 1998 Product SATalogue.

Sales/Warehouse - 84 Bayfield Road, Bayswater Victoria
 Construction Services - 13 Elsum Avenue, Bayswater Victoria
 Postal Address - PO Box 901, Bayswater 3153 Victoria Australia

**Phone: (03) 9738 0888
 Fax: (03) 9729 8276**

Echostar 4, launched in early May and heading for 119W has apparently experienced problems with solar panel deployment. It was to replace Echostar 1 at that location which in turn was to come to 148W (hence, our interest). Status of any Echostar at 148W remains clouded at presstime.

Aurora testing on Optus B3 (12.407 Vt, MPEG-2) is currently in CA format although cards allowing access to the service have been distributed to a handful of early purchasers of the UEC 642 receiver through distributor Nationwide Antennas. The line-up has been changing but should be similar to: (1) Business TV 2, (2) Horizon, (3) Pacific TV, (4) Business TV 1, plus radio channels Easy Listening, Top 100, Light Classical and Cafe Jazz. Observer **J.W. Marson** (Mooloolaba, Qld) reports the Msym is 30.000.

A Russian source advises, "Gorizont 33 (scheduled for August launch) and Express 3 (December launch) have now been taken off the launch list." Gorizont 33 is the last of the Gorizonts built, the intended location had never been made public. Express 3 appears to be cancelled following several

transponder failures on Express 1 and 2 (including the high power 3675 transponder on Express 2 at 80E).

Quick Asian roundup from David Leach (NSW): Ap2R: ZJTV 3760/1390Hz P5; Th3 3520/1630Hz, 3580/1570Hz, 3550/1500Hz, 3690/1460Vt, 3761/1389Vt. Best Insat 2C (93.5E) signals - 4128/1022Vt and 4162/988Hz.

"DOWN TO EARTH" - Opportunity

Innovative DTH SERVICE FOR AUSTRALIA and surrounding areas, offering new and interesting subscriber satisfying programming at realistic prices. A mix of movies, sport, news and general entertainment - 11 channels in a MCPC bouquet - using Ku-band transmission with a maximum dish size of 1.2m. All for AS20 per month.

Responsible programming delivered in a professional package for consumer pleasing pricing. Registrations of interest in being a part of this back-to-basics approach to pay-TV DTH service may be registered to the box number below. No phone calls please.

DTE, % SatFACTS, PO Box 330, Mangonui, Far North., NZ
(Equal opportunity service - NOT a Murdoch project!)

small, medium and LARGE C and Ku antennas in stock!

Transmit and receive antennas from 1.2m to 13m (Intelsat Standard B). Linear and circular feeds (AsiaSat, Palapa, JcSat, Rimsat, PanAmSat, Intelsat and more) for transmit and receive-only applications. Receive and transmit electronics including inclined orbit tracking equipment with motor drives for elevation and azimuth to 50 tons. Complete system design, fabrication, installation + proof of performance.

P
A
C
I
F
I
C



Limited

A
N
T
E
N
N
A
S

Pacific Antennas Limited

Bryon G.G. Evans, PO Box 265, Whangaparaoa, NZ
Tel/fax 64-9-424-0841 • Mobile 025-789-160



Comet Installations is pleased to announce the acquisition of ACESAT



which has now been relocated to our modern warehouse premises at 321 Parramatta Road Auburn, Sydney NSW 2144

Contact:

Tenders, Design & Installations - Allan Miller (Operations Manager)
Phone: (02) 9704 2975 Fax: (02) 9704 2977

Product Sales - Doug Sawtell
Phone: (02) 9704 2976 Fax: (02) 9704 2977

Comet Installations is Australia's largest Satellite & Cable Specialist with extensive experience in VSAT, TVRO, SMATV, MATV, Multi-media Interface, Head Ends, DTH and Cable.

COMET INSTALLATIONS PTY LTD ACN 071 673 562

AT

Sign-off

Cunning Like a Fox

On June 2nd, Foxtel did a typical Murdoch inspired back door assault on the Australian pay-TV world. It negotiated a deal with the bankruptcy managers for Australis/Galaxy to acquire a reported 65,000 Pace brand DGT-400 IRDs. Ten thousand of these are alleged to be sitting in an Australis warehouse, the remaining 55,000 are scattered all over Australia at nearly as many different addresses.

There is no official announcement as to what was paid for these IRDs but we understand the price worked out to around A\$157 per IRD. Now, what in the world does Foxtel want with 65,000 IRDs that are scattered around 55,001 locations?

The Australian for June 3rd reported, "Foxtel plans to offer an interim service to Galaxy subscribers who are receiving a signal from Austar due to be terminated shortly." Columnist Malcolm Maiden in other Australian press reported, "Foxtel could develop the interim service to keep former Galaxy subscribers with pay-TV and later it could opt to develop the service permanently and extend it."

Excuse me. I believe I have been witness to this once before. It was called British Satellite Broadcasting (BSB) and it operated for one year with purpose-built D-MAC analogue receivers. It failed and Murdoch picked up the infrastructure of BSB, merged it with his Sky Broadcasting and renamed the service BSkyB through the Astra satellite. The BSB service was kept on the air for two years and then turned off while during those two years BSB receivers were replaced with BSkyB receivers.

ACCC Chairman Fels in response to questions said, "Our only concern would have been if Foxtel had purchased the whole of the Australis business ... we don't have a problem with the acquisition of these set-top boxes."

Let me see if I can get this straight in my mind. If Foxtel had gone to Galaxy to purchase the infrastructure necessary to take over the Galaxy DTH service, Fels would have blocked it. But if Foxtel buys only parts of the DTH system, the ACCC does not mind. Even if the parts as bought separately ultimately go back together as a whole DTH system at the end? An analogy: If you are under age, you cannot purchase a package of cigarettes. But you are allowed to purchase one cigarette at a time, as long as you leave the package at the store. I guess that is 'Felsationalisation' of the pay-TV industry in Australia.

So here we have Foxtel as the proud owner of 65,000 IRDs for a reported \$157 each. Thrown in are the 55,000 dishes, LNBFs, pole mounts, cable sets and of course the installation labour that put them where they reside today. When you consider Galaxy paid on average \$130 just for the labour content to install those systems, Foxtel got one heck of a deal. Nobody is more cunning than "the Fox."

Austar and Optus had the same opportunity. Optus reportedly offered the Galaxy financial referees a "system management deal" by which Optus would have operated the

ex-Galaxy subscriber base for a period of nine months at the end of which they would decide whether they wanted to retain these subscribers as their own. Galaxy's financial managers turned the offer down. Austar as far back as March was negotiating with UEC for 30,000 of their 642 model IRDs in the price range of US\$300 each; considerably more than the A\$157 the cunning Fox paid.

The reality is that Foxtel did not merely purchase 65,000 IRDs at a bargain price; they bought entry into 55,000-plus new *subscriber* homes. As we point out in the extensive report in this issue (p. 6 - 15), Austar has licensing problems with serving ex-Galaxy homes in metropolitan regions. That could be changed, of course, by Government decision. And Optus apparently believed by co-controlling the Irdeto CA system with Austar, "the Fox" was shut out from serving the ex-Galaxy subscribers. *Silly Optus.*

The quick-British-Fox has just turned the pay-TV world upside down by purchasing not 65,000 IRDs for \$157 each, but 55,000 new DTH *subscribers* complete with the in-home hardware required to serve them for the lowest price ever paid for an almost-operational DTH service. In a world where DTH subscribers "sell" for upwards of US\$2,500 each, Fox has saved more than a billion dollars.

Now, how to serve those pay-TV hungry homes? By satellite, of course. Which satellite? B3 is obvious but this requires Optus to agree to lease them space (such as the recently abandoned twin transponders of Galaxy). Optus has their own agenda here - they want access to some of the exclusive-to-Foxtel cable programming as well as cash for Optus transponders. And as we point out on p. 14 here, B3 transponder space is significantly overbooked even without Galaxy (or their Foxtel replacement).

Which leads us to PanAmSat. The Australian on June 5th reported, "It is understood Foxtel has conducted successful satellite transmissions using the facilities of PanAmSat. The PanAmSat PAS-2 satellite has a large enough footprint to provide direct-to-home satellite signals to most Australian households in competition to Optus B3" (see p. 29, here).

Bingo. If you are the cunning Fox, and you really want on B3, announce you are going to another satellite. Threaten to bypass B3 altogether and watch how long it takes the folks at Optus to come running back to you with B3 on a golden platter. And if the people at Optus don't rise to the bait?

Well, you could actually go up on PAS-2 today or tomorrow if you wished and turn the satellite installers loose in the streets repositioning 55,000 dishes for the PAS-2 service. And then you could move to PAS-8 when it activates sometime after their October 9th scheduled launch date because it will be several dB better for Australia than PAS-2 is today.

What about the Austar + Optus co-ownership rights to Irdeto CA? Are not 65,000 DGT-400 IRDs now owned by "the Fox" equipped with Irdeto? They are. One solution is to yank the Irdeto CAM out of the DGT-400s and shove in an NDC compatible CAM, effectively changing CA systems and hopping over the Irdeto barrier. Won't all of this cost a lot of money? Remember - "the Fox" bought 55,000 subscribers for A\$157 each, in a market where they were easily worth US\$2,500. So they spend *another* \$157 to redo the CAMs and repoint the antennas - *not a big deal* in a world where 55,000 new subscribers will add more than A\$28,000,000 in new revenue to Foxtel in the first year.

It took two years to turn BSB subscribers into BSkyB people. The Fox is not only cunning, *he is patient.*

THE 1998 SATELLITE EXPLOSION IN THE PACIFIC/ASIA!

COMING TO YOUR DISH - New C and Ku services from Orion at 139E, and from AsiaSat 3S at 105.5E! PLUS - the maturing of digital DTH in the Pacific.

Stay tuned with SatFACTS!

- ENTER my 12 MONTH subscription to SatFACTS starting with July 15th issue (rates below)
 ENTER my 36 MONTH subscription to SatFACTS starting with July 15th issue (rates below)

NAME _____

Company (if applicable) _____

Mailing address _____

Town/city _____ Country _____

Amount to send: 1 year - NZ\$60 (inside New Zealand) / A\$90 (inside Australia) / US\$60 (outside of NZ and Australia) or 3 years - NZ\$140 / A\$210 / US\$150 if by cheque. **VISA** or **Mastercard**? See form below and return with order. Return to: **SatFACTS, PO Box 330, Mangonui, Far North, New Zealand** or if by VISA or Mastercard fax to 64-9-406-1083

ALL SatFACTS SUBSCRIPTIONS ARE SENT VIA AIRMAIL - WORLD-WIDE!

USE THIS FORM ONLY WHEN CHARGING ON VISA/MASTERCARD

Please charge my **VISA/Mastercard** as follows:

- ONE Year of SatFACTS MONTHLY (NZ\$60, A\$90, US\$60)
 THREE Years of SatFACTS MONTHLY (NZ\$140, A\$210, US\$150)
 SATELLITE TELEVISION: The Booklet (NZ\$10, A\$12, US\$10)
 One Year of COOP'S TECHNOLOGY DIGEST (NZ\$125, A\$125, US\$125)

Indicate charge card type: VISA Mastercard

Name (as it appears on **VISA / Mastercard**) _____

VISA/Mastercard Number _____

VISA/Mastercard expiration date _____

Instructions: If ordering by mail, return this complete (3-part) card or a copy of same (to **SatFACTS, PO Box 330, Mangonui, Far North, New Zealand**); if order by FAX, send full card as a single sheet to **64-9-406-1083**

SUPPLEMENTAL MATERIALS from SatFACTS MONTHLY: Order Form

- SATELLITE TELEVISION:** The Booklet. Excellent introduction to home dish ownership for the layman, including major contributions from the father of geostationary satellites - famed science fiction writer *Arthur C. Clarke*. The perfect tool to help the satellite system seller explain home satellite TV to the layman consumer. From SPACE Pacific. NZ\$10/ A\$12 / US\$10, airmail.
- COOP'S TECHNOLOGY DIGEST.** For the really serious enthusiast, investor, business person in satellite television and allied leading edge technologies. Ten issues each year, jam-packed with information you will not find anyplace else. "Coop" routinely culls more than 60 publications world-wide, terribly expensive newsletters, Internet and his hundreds of private contacts to keep you right at the leading edge of technology on the **REAL** changes underway in telecommunications. Conveniently issued near the **first of the month**, creating an excellent time-line-filler between the mid-month issues of SatFACTS. Now in the 5th year, airmail world-wide. Normally NZ/A/US\$250 per year - for SatFACTS subscribers special **50% discounted** price of NZ/A/US\$125.

OBSERVER REPORTING FORM - Due JULY 4, 1998

- NEW programming sources seen since June 1st: _____
- Changes (signal level, transponder, programming content) in pre-existing programming sources since June 1st: _____
- OTHER (including changes in your receiving system): _____

NOTE: Please use P1 - P5 code when describing signal levels and receiver IF/RF settings.

Your Name _____

Town/City _____

Make/size dish _____ LNB _____ Receiver _____

Your email address _____ if you have one!

MAIL TO: SatFACTS Monthly, PO Box 330, Mangonui, Far North, NZ or fax 64-9-406-1083

email - DO YOU HAVE email CAPABILITY?

AN EXCITING NEW SERVICE from SatFACTS is coming. And we'll give you just one clue: "It is NOT monthly!" If you have email capability, and would like faster updates - return this card!

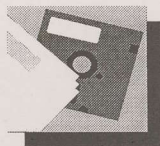

+

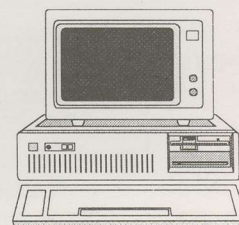

YES - I AM on-line with email!

email address _____

My name _____

Mailing address _____

Town/city _____

Mail or FAX this form to SatFACTS-Q, PO Box 330, Mangonui, Far North, NZ or fax to 64-9-406-1083

SPACE INFO PACK?

Looking for the "inside track" to more sales and greater profits in satellite systems? The trade association SPACE Pacific may be able to help.

YES - Send membership details for SPACE Pacific to ...

NAME _____

Company (if applicable) _____

Mailing address _____

Town/city _____

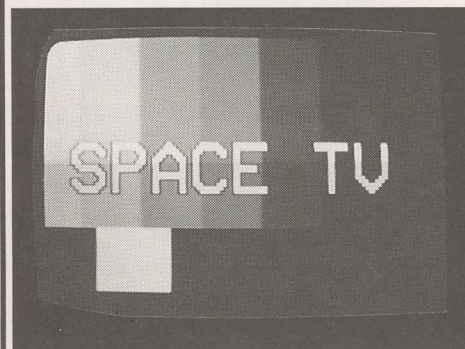

SPACE Pacific Ltd.
PO Box 30, Mangonui, Far North
New Zealand
Fax 64-9-406-1083

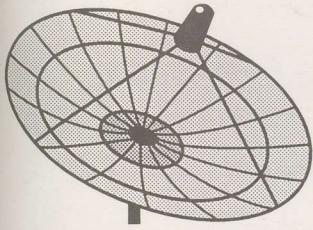

AV-COMM SATELLITE TV EQUIPMENT

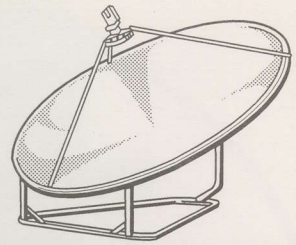

FREE TO AIR DIGITAL SATELLITE RECEIVER R3100

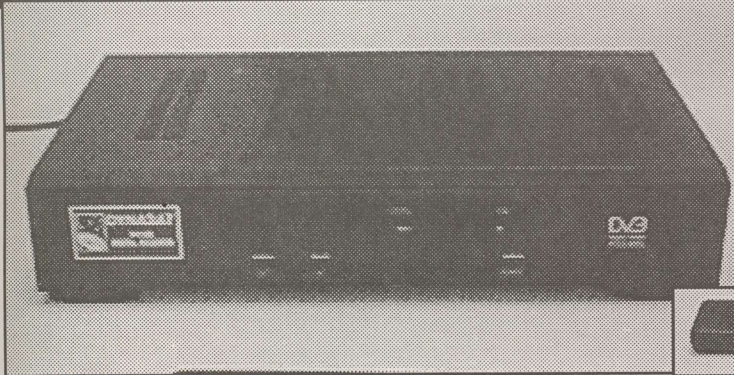

Cat # R3100

ONLY
\$1145

Call
for
export
price

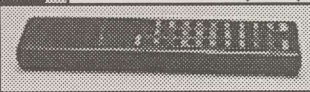

FEATURES

- ◆ 950-2150 extended frequency coverage, C & K band
- ◆ 14/18V LNB polarity selection
- ◆ MCPC & SCPC
- ◆ 22KHz tone switching for dual input ops.
- ◆ Downlink signal margin indicator
- ◆ Dual channel audio
- ◆ Channel "edit" facility
- ◆ 0-12V output for dish selection
- ◆ S-VHS video output
- ◆ Auto FEC detect

DYNALINK MANUAL TUNED RECEIVER R1100

SPECIFICATIONS

- ◆ 950 - 2050MHz IF Input range
- ◆ Low threshold operation
- ◆ Stereo audio
- ◆ 14/18V LNB switching
- ◆ 18/27MHz IF Bandwidth.

Ideal for band scanning, channel monitoring, or as the heart of any home satellite receiving system.

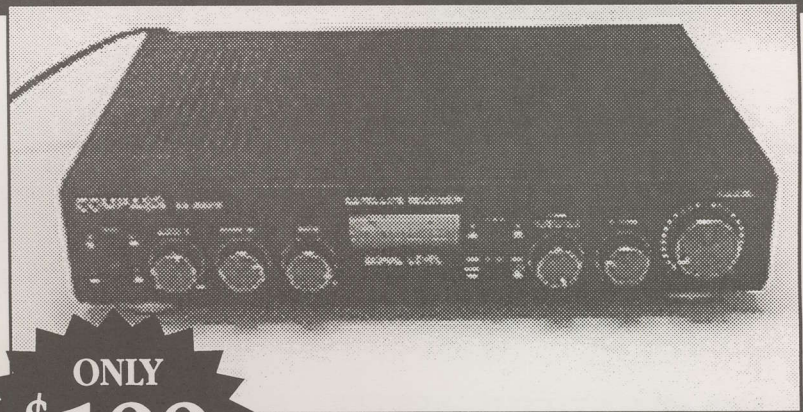

ONLY
\$199

Call for
export price

Cat # R1100

AV-COMM PTY. LTD.

DIRECT IMPORTER ACN 002 174 478

PO BOX 225, BALGOWLAH 2093

TEL: 61 2 9949 7417 9948 2667

FAX: 61 2 9949 7095

VISIT OUR WEB SITE AT

<http://www.avcomm.com.au>

*We reserve the right to improve product performance without notice.

✓YES GARRY, Please send me more info...

Name: _____

Address: _____

_____ P'code: _____

Phone: _____



UNCLE BAYSAT ASKS

**have you ever had
trouble getting a
refund for goods
that were
unsatisfactory???**

DEAL with BAYSAT
and rest easy
in the knowledge
you are PROTECTED
by a 7 day
money back guarantee * -

NO QUESTIONS ASKED!

Don't get
caught out
ever again
with a deal
that comes
unzipped!

* - The fine print. As long as goods are returned in 'as new'
condition with original packing intact.

BAY SATELLITE TV LTD

YES!

We STILL accept
VISA, Mastercard with
NO surcharge!

PO Box 3311 • Napier, New Zealand • tel toll free 0800 - BAYSAT
International 64-6-843-5296 • Fax 64-6-843-6429 (0800 - 229-728)
Physical location • 19B Carnegie Road, Onekawa, Napier
<http://www.baysat.co.nz>