

14-05-98 9AM

Bob Cooper's

MAY 15 1998

# SatFACTS

MONTHLY



Reporting on "The World" of satellite television in the Pacific and Asia

## IN THIS ISSUE

**LAST OF THE  
ANALOGUES-  
"With A Bang!"**

**NEW FOOTPRINT  
MAPS NOT  
IMPRESSIVE**

**Optus Goes Cheap-  
Aurora Goes Cold-  
Sky Will Be Late**

- ✓ Latest Programmer News
- ✓ Latest Hardware News
- ✓ Latest SPACE Pacific Reports
- ✓ Cable TV Connection

**Vol. 4 ♦ No. 45  
Price Per Copy:  
NZ\$9/A\$10/US\$7**

## THE LAST HURRAH?

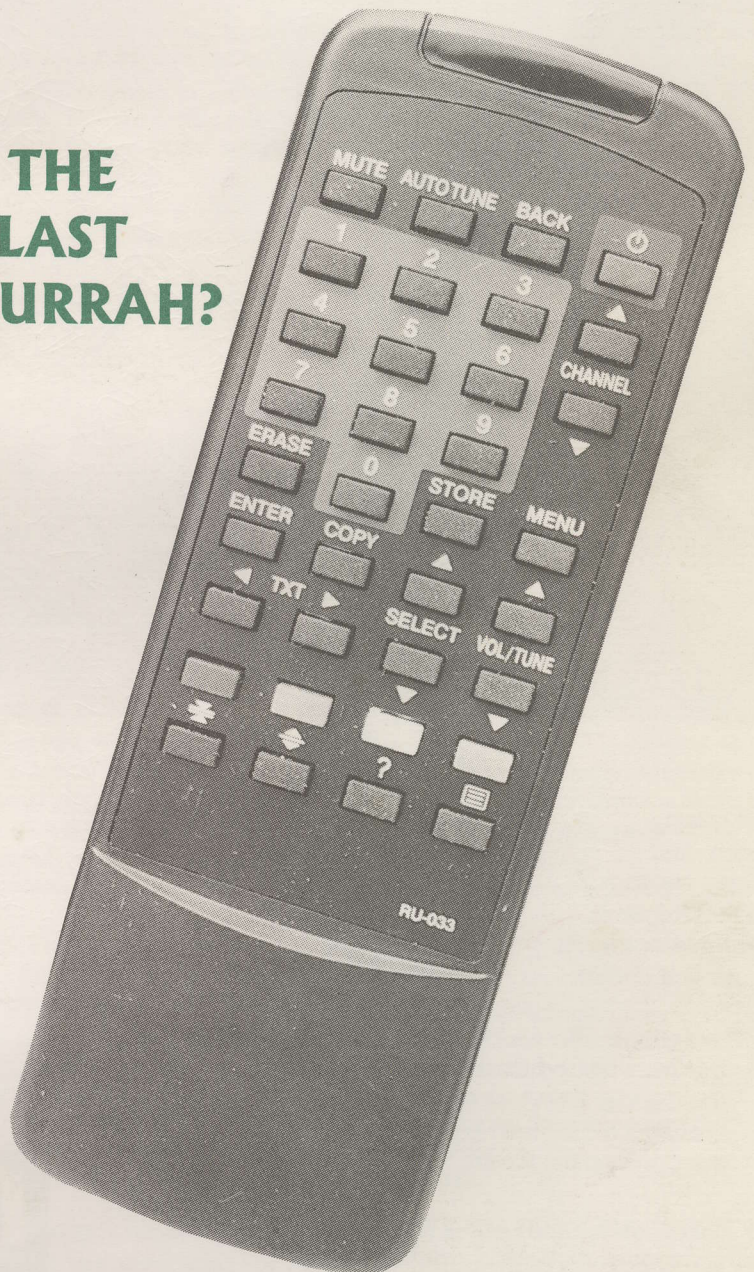

## AUSTRALIS / GALAXY in Receivership!



# Paracclipse<sup>®</sup>



CLASSIC  
SERIES

ECLIPSE  
SERIES

HYDRO  
SERIES

When quality, strength, and accuracy are your main requirements, **Paracclipse** antennas are your first choice.

Only **Paracclipse** offers such variety; four distinctly different series: the Truss-Ribbed Classic, the Courier Deliverable Eclipse, the Stretch Formed Hydro, the Commercial Patriot.

Every **Paracclipse** model sets the industry standard in its class, worldwide.

Distributed in Australia by

**SKANDIA ELECTRONICS Pty Ltd.**

183 Burwood Rd, Hawthorn, Melbourne  
tel 61-3-9819-2466 • fax 61-3-9819-4281

Level 1, 39 Terry St, Rozelle, Sydney  
tel 61-2-9555-2955 • fax 61-2-9555-2455

**SATECH Satellite Communication  
Technology P.T.Y. L.T.D.**

6/477 Warrigal Rd, Moorabbin East, Vic.  
tel 61-3-9553-3399 • fax 61-3-9553-3393

Distributed in New Zealand by

**Bay Satellite TV Ltd.**

PO Box 3311, Napier  
tel 64-6-843-5296 • fax 64-6-843-6429

# Paracclipse<sup>®</sup>

HIGH PERFORMANCE ANTENNAS

Paracclipse Inc.

2271 29th Avenue East, Columbus, Nebraska USA 68601

Telephone: (402) 563-3625

Fax: (402) 564-2109

★ **MADE IN  
AMERICA**



# SatFACTS MONTHLY

ISSN 1174-0779

is published 12 times each year (on or about the 15th of each month) by Far North Cablevision, Ltd.

This publication is dedicated to the premise that as we enter the 21st century, ancient 20th century notions concerning borders and boundaries no longer define a person's horizon. In the air, all around you, are microwave signals carrying messages of entertainment, information and education.

These messages are available to anyone willing to install the appropriate receiving equipment and, where applicable, pay a monthly or annual fee to receive the content of these messages in the privacy of their own home. Welcome to the 21st century - a world without borders, a world without boundaries.

**Editor/Publisher**  
Robert B. Cooper (ZL4AAA)  
**Office Manager**  
Gay V. Cooper (ZL1GG)

#### Reaching SatFACTS

Tel: 64-9-406-0651  
Fax: 64-9-406-1083  
Mail: PO Box 330  
Mangonui, Far North  
New Zealand

#### Subscription Rates

Within NZ: \$60 p/y  
Australia: AV-COMM Pty Ltd, PO Box  
225, Balgowlah, NSW 2093  
61-2-9949-7417

Elsewhere: US\$60 p/y  
All copies sent via airmail fast post  
world-wide

#### ERRATA

SatFACTS Copyright 1998 by Robert B. Cooper; any form of copying is a violation of our international copyrights. Advertising rate sheet available upon request.

## COOP'S COMMENT

Suppose *you* spent \$6,666 for the parts making up a satellite DTH installation, and then agreed to accept payment from your customer at \$49.95 per month. It would take you 133.5 months (11+ years) to get back your original \$6,666, not to mention a profit for your work. How long might you stay in business with this as a "business plan?"

*Galaxy has gone into receivership. They are \$600 million in debt because that is how much they have over spent getting pay TV to approximately 90,000 subscribers. It works out to \$6,666 per subscriber with a "return" of \$49.95 per month. Their situation is actually far worse than \$6,666/133.5 months because the \$49.95 they collect must first pay programming costs, then distribution via MMDS or satellite, finally for their staff and general operations. If - that is a large IF - they actually manage to "profit" by \$5 per month out of the \$49.95, it would be a surprise. And at \$5 per month, the \$6,666 would require 1,333 months (111 years) to pay off. Just to pay off - forget about a profit!*

The wonder here is that highly paid professionals in pay-TV, operating Galaxy, allowed this to happen. There is a strange, almost hypnotic aura that surrounds pay TV projects no matter how badly conceived they might be. When Sky NZ released a portion of its stock to the public this past November, reportedly the offer was over subscribed by 5 times. No matter that until that point Sky had never made a profit, no matter that Sky was embarking into digital with new technology never before tested. The public that subscribes to new stock or bond offerings is perhaps overpowered by glossy brochures portraying satellite dishes, huge control room consoles filled with banks of monitors all displaying different pictures, and heart pumping phrases like "digital" and "Internet" and "home shopping and banking."

I saw an amusing three lines on Internet recently that goes like this.

*"It does not work."*

*"But - I thought it was state-of-the-art."*

*"That is the state of the art!"*

It is not that digital TV does not work; we all know it works ... sometimes. It is not that conditional access, and smart cards and telephone line modems processing viewer order selections do not work; they do, sometimes. It is that all of this is brand new, that the consumers are totally unfamiliar and horribly confused by the new system. Moreover, it is that the cost of making this wondrous system perform as advertised is always greater - some say 300% greater - than initially forecast. You can be certain Australis / Galaxy did not originally project a cost of \$6,666 per subscriber at the 90,000 subscriber level. More likely, the number was under \$1,500 per subscriber. But glitches happened, things did not work "as advertised," and it cost more (non-scheduled) money to fix it so it would work. After several years of patching the system up with \$30 million here and \$100 million there, the financial receivers were called in to Australis/Galaxy.

As long as there are punters willing to take a gamble, for as long as pay-TV appears to be "the next great profit centre" of commerce, there will be Australis failures. Investors have all heard stories about the first people who bought stock in Alexander Graham Bell's new system, most have heard how Rupert Murdoch has become a paper billionaire on the back of his pay TV ventures. Sadly, most will never hear about Australis.

#### In Volume 4 ♦ Number 45

ANALOGUE SWAN SONG? Palcom's SL7700RP -p. 6  
New Footprint Maps Not Impressive -p. 10  
AV-COMM's R3100 Sets New Digital IRD Performance Standards -p. 20

#### Departments

Programmer/Programming Update -p.2; Hardware/Equipment Update -p. 4;  
SPACE Notes (Permission For a Dish) -p. 24; Cable Connection  
(Tight Connections) - p. 26; SatFACTS Orbit Watch -p. 28; MPEG-2 Tuning Parameters -p. 30;  
Digi Notes Reference Information -p. 32; With The Observers -p. 33;  
At Sign-Off (Defining The Aurora + Optus DTH Product) -p. 36

#### -ON THE COVER-

The current release of analogue receivers represent bargains in price and performance we could but dream about two years ago. The Palcom SL7700RP does everything but hold your hand in what may be the ultimate analogue "machine." (p. 6)

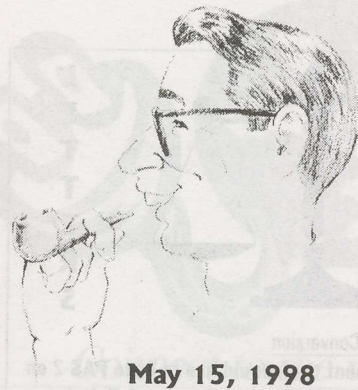

May 15, 1998



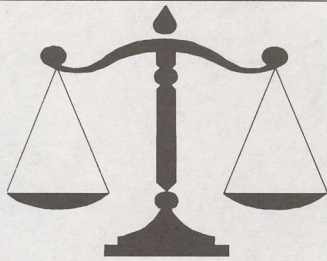

#### Video Format Conversion

"I have a client that would like to have PAS-2 on a 3m dish to pick up both analogue and digital services. This is a hotel and they do not have multi-system TVs. Is it possible to install a particular tuner instead of digital converters so the hotel does not have to replace their TV sets?"

Julia Weber, Victoria, Australia

There is a belief, incorrect at this time, that MPEG IRDs are or will be available that do video format standards conversion internally, such that an NTSC input signal (such as CMT) can be outputted to PAL. Technically, it would be possible for a digital IRD to process NTSC in as PAL out and some Nokia red screen menu options allow a form of this to be done. The Nokia's aside, there are no readily available IRDs that add standards conversion to MPEG processing at this time. In the case of your hotel, the answer is far less complex. For each off-satellite signal received and processed for viewing in hotel rooms on standard PAL format TV sets, install (1) an appropriate IRD or analogue receiver, (2) a standards converter (where required - such as for an NTSC service), and, (3) a PAL format modulator on a specific channel for distribution within the facility. Any TV sets plugged into the hotel distribution system then receive a PAL format video signal on a standard PAL RF channel.

#### Digital Course

"I am interested in doing the Digital Satellite TV Installer Certification Course described in SatFACTS from SPACE Pacific. Will the course assist me in getting into more advanced systems such as delivery of Internet via satellite? I am an experienced Sky TV installer in the Manawatu (region) and would like to progress into digital satellite TV."

Peter Stuart, Rural Energy Systems, Palmerston North  
Knowing what digital is and how it works will be the key to a rewarding and challenging career in the telecommunications world. Not understanding digital is a passport to oblivion. We will say it again - the digital world reinvents itself currently every 15 to 18 months. Those who don't learn "to speak" digital - now - will be condemned to second rate jobs and third rate pay in the future.

#### Indovision MPEG-2 IRD?

"Can you supply information regarding obtaining Indovision (Pace 211) IRDs?"

Alvi Tohesanau, Honiara, Solomon Islands (677-22858)

As the two reports to the right indicate, Indovision service to PNG (and by reference your location) is at best an unsettled legal question. There is a firm in PNG supplying IRDs but they have had some problems with the programmers who claim PNG is not in the authorised service region. Moreover, if Indovision is really moving to S-band perhaps you should wait until that is finalised before making an investment.

## PROGRAMMER PROGRAMMING PROMOTION

## UPDATE

MAY 15, 1998

**NBC** is shutting down "NBC Asia" transmissions (PAS-2, digital bouquet at 4093 Vt) July 1, replacing with new National Geographic Channel Asia (NGCA). Approximately 4 hours of "NBC" material will continue on the schedule (specifically mentioned: Today Show, Tonight with Jay Leno, Late Night with Colin O'Brien, Dateline). A version of NGCA has been available on Foxtel Cable (Australia) since September, and this specific service is 50% owned by News Corporation. NBC plans to convert existing NBC affiliates to NGCA but no details have been released; NZ is likely to be passed over because of copyright. NBC Hong Kong personnel are being reduced by 75 people as part of the consolidation; CNBC is not affected.

**Danger in selling** a home dish system built around current availability of a single service - especially when programmer is not on satellite for the express purpose of delivering DTH. RAI/ART PAS-2 MPEG-2 feed (4153/997 Hz) has been available since last August, Australians with dishes down to 2.4m and New Zealanders down to 3m have benefited. Early in April, transponder power was backed down several dB and most systems lost service. Installers were caught in the middle by irate customers who did not understand why their previously functioning dishes no longer played. Be warned. (Note: Later in April, power was turned back up - PanAmSat blamed the decrease on "power balancing" adjustments. Interpretation: Solar equinox time of year, need to adjust satellite operations to reflect lower available sunlight for solar powering of system. See p.4 and 35 here for more on RAI via PAS-2)

**KIBC** (AsiaSat 2, with Hallmark bouquet) has changed Internet address to KIBC.com, is looking for assistance in merchandising KIBC "materials" overseas. KIBC encourages direct contact through e-mail or fax (+ +63 47 252 6145).

**ABC interchange** (PAS-2, Ku); 12.626 has varying video/audio PIDs as feed locations change. Receivers that show lock but no video might try reloading in new memory position when this happens: PIDs of 1160/1211, 2160/2120, and 1110/1120 are common (alternate) feed source numbers.

**EMTV** was supposed to be PowerVu CA after April 20 visit of Sydney engineer; it was not although he *thought* it was and left Port Moresby for home believing he had turned it on. SA scores again.

**Other PNG problems.** It seems MGM Gold and Star Sports, both on the Palapa C2 Indovision package, have been sold by an "authorised" programme distributor to home DTH systems there. **ONLY** - the "authorised" was not authorised and PNG was not in the list of approved countries for these two services. The distributor has been told to "cease and desist" and some customer IRDs have been shut down - much to his embarrassment. Subsequently, MGM shut down all operations at Indovision.

**Speaking of which** - a Jakarta newspaper report insists all Indovision C2 digital programming will be shut down July 31 in favour of switching all customers to S-band Catawarta at 107E which was/is due to "turn on" in May. Indovision shut down the last of the C2 B-MAC analogue services (HBO) on April 15th, forcing viewers to reinstall (Pace) digital IRDs for continued service from the C2 Indovision bouquets. **NOW** - they are telling these people they will have to switch their feeds, LNBs and repoint their dishes if they wish to continue watching Indovision. Talk about a business plan likely to piss customers off! Pace, by the way, has closed its Asian office after delivering only 35,000 digital IRDs there. Indovision says they will use Thomson (RCA) brand IRDs from now on. Pace is now servicing Asia and the Pacific from Sydney (Australia) - welcome to Laurie Knight who arrived just in time to tie the knot on contracts with Sky NZ and (cable?) set top boxes for Foxtel.



# NEW STOCK HAS ARRIVED

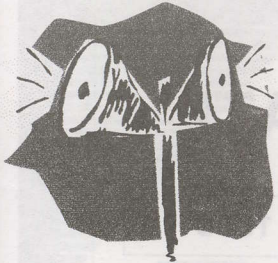

AT  
**Skandia**

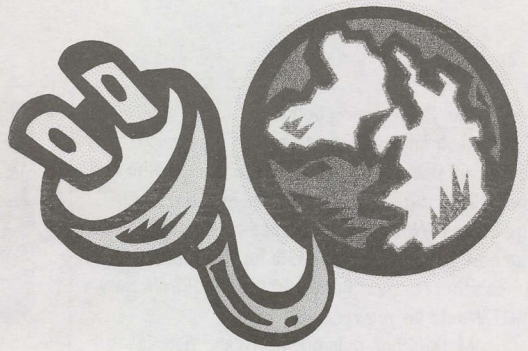

*Connect to the world ...*

## SAT1024 - Hyundai HSS-100C Digital MPEG 1 & 2 and FTA PowerVu

- \* Will receive all FTA including CMT, Chile TV and BBC world on PAS2, RAI and ART on PAS2
- \* All Mainland Chinese Channels on AsiaSat2, European bouquet, all Programmable simultaneously!
- \* Has 99 bouquet capability
- \* 5.5MHz sound sub-carrier on RF modulator
- \* No freeze frame on NTSC Power Vu
- \* No lip sync problems, on screen channel ID and signal meter.

**TRADE \$726**  
**W/SALE \$599**



## SAT1026 - SRT230LT Strong Receiver

- \* 2 IF Inputs tuner with 2 bandwidths (18/27 MHz) switching.
- \* Low threshold tuner circuitry 32 steps.
- \* Universal LNB (900-2150 MHz) compatible.
- \* Mechanical Polariser connections.
- \* 250 fully adjustable channels.
- \* Full On-Screen Graphics.
- \* Video timer. Real time calender.
- \* Four languages (English, French, German, Italian).
- \* C/Ku band selection.
- \* 3 output SCARTS.
- \* 4 RCA Jacks.
- \* Independent tuning of left and right audio channels.
- \* Wegener Panda 1 audio de-emphasis.
- \* 8 step audio bandwidth.
- \* Volume control 32 levels.
- \* 0/12 volt switching.
- \* Full UHF (21-69 Ch.) PLL modulator.
- \* Parental Lock.
- \* Compact size.



**TRADE \$234**  
**W/SALE \$199**

## SAT1040 - Palcom Analogue Receiver / Positioner

- \* 500 Programmable channels.
- \* Switchable IF Bandwidth 27/18MHz and TED in 8 steps.
- \* Teletext - Arabic, Cyrillic, English/Europian, Hebrew.
- \* Multi-lingual, English, German and French On-screen Dialogue.
- \* Infrared Data Transfer. (via INTELLIGENT REMOTE CONTROL IR-100)
- \* Integrated Antenna Positioner with East-West and North-South control.
- \* Inclined Orbit Timer for East-West and North-South Actuator.

**TRADE \$445**  
**W/SALE \$399**

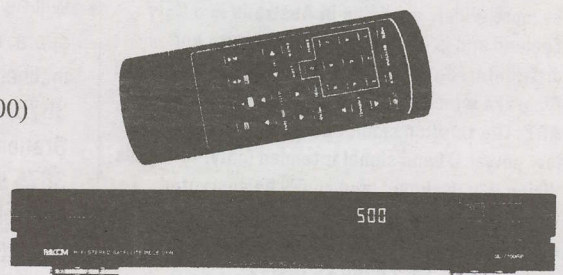

CQ:220498

Free to Air

**Skandia**

**SATELLITE**  
**SPECIALISTS**

Skandia Communications Pty Ltd

Victoria: 183 Burwood Road Hawthorn 3122, Australia

NSW: Level 1, 39 Terry Street, Rozelle 2039, Australia

SatFACTS May 1997 • page 3

Telephone: (03) 9819 2466 Fax: (03) 9819 4281

Telephone: (02) 9555 2955 Fax: (02) 9555 2455



#### Wants Own Programming Source

"We seek advice on how we can transmit from 1 to 4 programming channels to the Pacific Rim and the islands with an uplink either in Australia or the States. What are the procedures, costs? Could the new programme channels be incorporated into an existing receiver or would they require a new IRD? Would you recommend?"

M. Durscher, Colorpix, Armsdale, Victoria

Recommendation: Hire a consultant to guide you through the myriad of choices (and decisions) that you will have to make. In Australia, we recommend Eric Fien at Broadnet International (tel + +61-42-724122). Choice 1 - which satellite? It depends upon the content of the service, and the market region you are trying to reach. Each satellite has unique coverage beams and you will select the satellite that most closely approximates your intended market region. Next choice - which band? This is a subset of the 'which satellite' problem, but more involved. Will the service be for DTH (direct to home)? If yes, Ku is a better choice than C simply because receive antennas are smaller and less expensive. Unfortunately, Ku-band coverage tends to be more focused than C and you give up full Pacific coverage (not available on Ku) for smaller receive antennas. All of this starts with a business plan defining who the intended market is, and where they are located. Once you have settled on a satellite, or satellites, the next step is to negotiate the best space segment contract you can. The amount of bandwidth required (part or whole transponder), how long a term you can commit for, influence the per day/per month charges for the space segment. Simultaneous to this negotiation, you should be looking at the options available for transmission format. Analogue is an unlikely choice anymore; the choices within the "digital realm" are many. Could you use a transmission format which is compatible with existing receivers? Yes, but only if the programming is intended to be FTA (free to air). If it will be conditional access (and sold by subscription), you will need to select an IRD source and companion CA (conditional access) system which makes economic sense.

#### RAI Australia Straight Talk

"Reference Pietro Casoar letter p.2 April concerning questionnaire we ran in Italian language press in Australia. The initiative to probe the market on distribution choices which includes DTH came from us, not Optus. There was no role for Optus Communications or Vision. There is no doubt RAI International would like its programs to be more widely available in Australia and New Zealand and is working to this end with our distributor, Saudi Arabian holding company Dallah Albaraka which also distributes Arabic channel ART. The solution cannot be DTH from PAS-2, a low power C-band signal intended (only) for Optus Vision which should (and could) be encrypted. Installers who recommend this solution risk facing unhappy customers and I encourage them to talk with us at + +61-2-9299-6535 (fax + +61-2-9299-5366). Congratulations on SatFACTS, especially your April DTH article and the At Sign Off column."

Claudio Paroli, RAI International, Australia & NZ  
See top of page 2 for our recommendation.

## HARDWARE EQUIPMENT PARTS

## UPDATE

MAY 15, 1998

**Australian sales tax** on satellite receivers. Some say 22%, some say 32%. It appears there is a level of "discretion" in the hands of ATO personnel when assigning an applicable sales tax to imports by individual receiver importers. Those now paying 32% rightfully feel handicapped in marketplace against competitors who are paying 22%. Indications are 22% is correct rate but if 32% is ruled correct, importers who have been charging 22% *could* get back-billed for charging too little. This one is messy and formal investigation is on-going.

**Ku band LNBs.** Tough to find in the lower noise figure region (0.7 dB and below) and expensive when (if!) you can locate them. Low symbol rate (narrow band) transmissions demand low phase noise, high stability (+/- 750 kHz to +/- 250 kHz) LNB/LNBFs. "DRO" device in LNB is key to good performance. Primary quality supplier has been Norsat (Canadian company); newer products are now coming on line from Taiwan sources. Services such as MediaSat, PAS-2 Imparja require better-than-home-DTH quality LNB(F)s - be aware.

**Sky Network NZ** decision to purchase Pace Micro Technology CA IRDs not a surprise given Murdoch financial interest in Sky, previous selection of Murdoch NDS for encryption, and, history of dealing with Pace for Murdoch controlled DTH systems. Pace receiver is described as "*standard model, no frills, not of the same technical calibre as new B-series (BSkyB) unit.*" Is, in fact, identical to unit being supplied to Mexico, Brazil DTH (also Murdoch controlled) except operating (on screen) language is in English. Receivers are scheduled to arrive October-November, followed by two month change over of existing B-MAC analogue units. First serious effort to expand satellite universe size - after January 1. IRDs cost Sky around US\$340.

**PanAmSat** says their PAS-8 footprint maps are "proprietary" but web sites have them. Bad news for New Zealand, Pacific regions east of Australia. Levels in 27 dBw region cut through New Zealand, central Pacific on C-band (Australia is 33 dBw or better). Ku band is worse again - official maps don't include New Zealand, but sharpness of footprint fall off east of Australia computes to levels in low to mid 30's - at or below present Optus B3 horizontal levels for Kiwi users. Details on p. 14 here.

**Optus Aurora** project IRD selection appears to have run aground. By their own forecast, Aurora was supposed to be delivering UEC Irdeto equipped IRDs by June 1st to RABS users. The first 40 arrived May 7, next UEC shipment not expected soon. There are some problems here; see p. 36.

**Intersputnik** (Moscow) remains uncertain when last of generation Gorizont (#33) will be launched, or where it will go when launched. Satellite was originally on-ground spare, now is rapidly running out of "use-by date" as C.I.S. abandons concept of inclined orbit satellites. Express 6 at 80E has one broken transponder (the 65 watt 3675, unfortunately) and all remaining transponders are northern beam only. Stationar 13 shares this orbit location solely for purpose of providing (sometimes) 3675 service, but it is inclined. Intersputnik (the organisation) says they no longer control birds at 96.5E, 103E, 140E, 145E or 161.5E. But they claim to own bird at 122E (which AsiaSat calls "G"). Confused? You can talk in English with Intersputnik personnel at + +7-095-244-0333 (fax + +7-095-253-9906).

**ApStar 1** (138E) was struck by apparent misguided uplink transmission in March 14th incident which operators at APT Holdings have attempted to hush up. Interference to transponder carrying data links to stock brokerage, paging firms and earthquake warning network shut down regular users. ChinaSat officials launched an investigation and quickly "guessed" interfering uplink originated outside of mainland China, citing Taiwan and Macau as "possible" sources.



# ADL<sup>®</sup>

BECAUSE PERFORMANCE IS ALWAYS YOUR FIRST PRIORITY

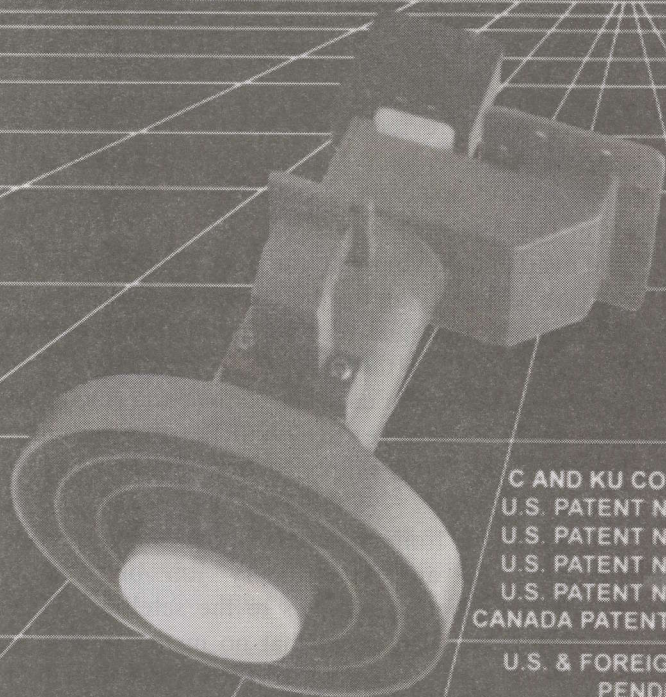

RP3-CKU/ International  
Adjustable Scalar Ring Feed  
with Extended C Band

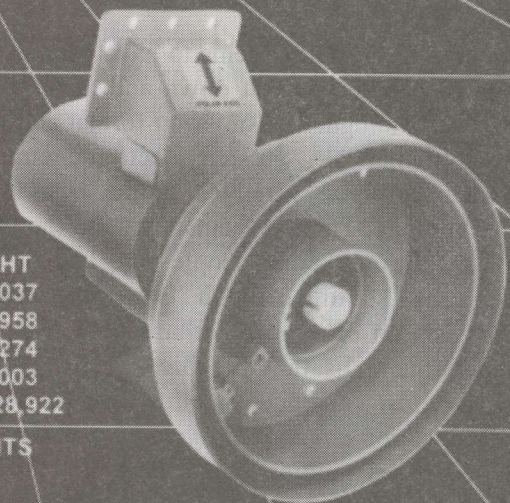

RPI-CKU Feed

C AND KU CO-BORSIGHT  
U.S. PATENT NO. 4,903,037  
U.S. PATENT NO. 5,066,958  
U.S. PATENT NO. 5,107,274  
U.S. PATENT NO. 5,255,003  
CANADA PATENT NO. 1,328,922

U.S. & FOREIGN PATENTS  
PENDING

## ADL HYBRID MODING CIRCULAR POLARIZED INTELSAT FEEDS WITH EXCLUSIVE T.I. REJECTION



RP1-CP400

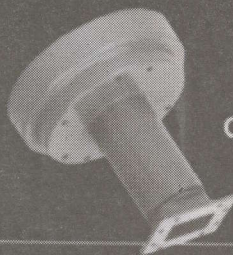

CP-300



CPOR-100

- C BAND LINEAR & CIRCULAR • C/KU LINEAR & CIRCULAR • KU 12 GHz FEEDS
- INTELSAT 4 GHz CIRCULAR • ARABSAT S BAND FEEDS
- OPTIONAL: CO-BORSIGHT S BAND

2216 AGATE COURT, UNIT B, SIMI VALLEY, CALIFORNIA 93065 • (805) 526-5249 • FAX (805) 584-0634

E-mail: [ADL@thegrid.net](mailto:ADL@thegrid.net) • Web site: <http://www.thegrid.net/adl/>



## FINAL BREED OF ANALOGUE RECEIVERS EXCEPTIONALLY GOOD - PALCOM SL-7700RP

The very first analogue consumer satellite receiver was built in 1978 by a company out of Canada calling itself Norsat (the same Norsat that today sells LNBs). It had a US\$1,995 price tag on it which was outstanding at the time since the only alternative - commercial receivers from the like of SA - cost upwards of US\$5,000. Twenty years and hundreds - perhaps thousands - of receiver designs later, we approach the end of the analogue product era. Palcom, at least, finally has it right.

The Palcom SL-7700RP seems to have been designed by a team of people who sat down and made a list of every possible analogue transmission format and variant and then systematically created electronic circuits to process each of these variables to the best level of current technology. Then, it seems, they ran the finished prototype by the marketing people who had their own list of demands - starting off with "Better *and* cheaper!". With emphasis on *cheaper*. Perhaps both teams were motivated by the realisation that this was likely to be the last - *the very last* - analogue satellite receiver design to go into production; *a legacy to the analogue era*.

The 7700 does nothing others have not previously tried to do. The twin motor drive control systems (one each for horizontal - azimuth - and vertical - up and down as in tracking inclined orbit birds) have been previously available (Drake, for one). The low threshold video reception (through seven steps of threshold extension) is now standard on most receivers. The audio bandwidth selections (130, 180, 280, 380 and new this

time around - 500 kilohertz bandwidth) are standard on any top of the line products. So too the audio de-emphasis circuits available (J17, 75 and 50 nanoseconds, and the previously available on model 7900 "hi-fi 1600"). So it is not that Palcom has created any brand new technology - rather it is that they have refined what was previously available to a new standard of performance.

### If It Is In The Air ...

...and available on your satellite dish, the 7700 will do a better job of displaying the picture and reproducing the sound than any analogue receiver previously tested by SatFACTS. In a word, the images are "brilliant" and no matter what receiver we used for comparison (including the far more expensive SL-7900RP), the reception quality from the 7700 is simply "better." Sometimes by a very wide margin.

We all know from experience that some satellite programmers do an extraordinary job of creating technically pure uplink services to the satellite (NHK, for example). We also know that no matter how good the uplink signal, some satellites do a less than high quality job of turning the signals around and transmitting them back to earth (any Gorizont, for example, somehow manages to turn a good quality image into something less pleasant to watch). We also know that other programmers transmit a low quality image to the satellite (GMA on C2, RTPi and ERTU on As2) and no matter how good the receiver, it comes out

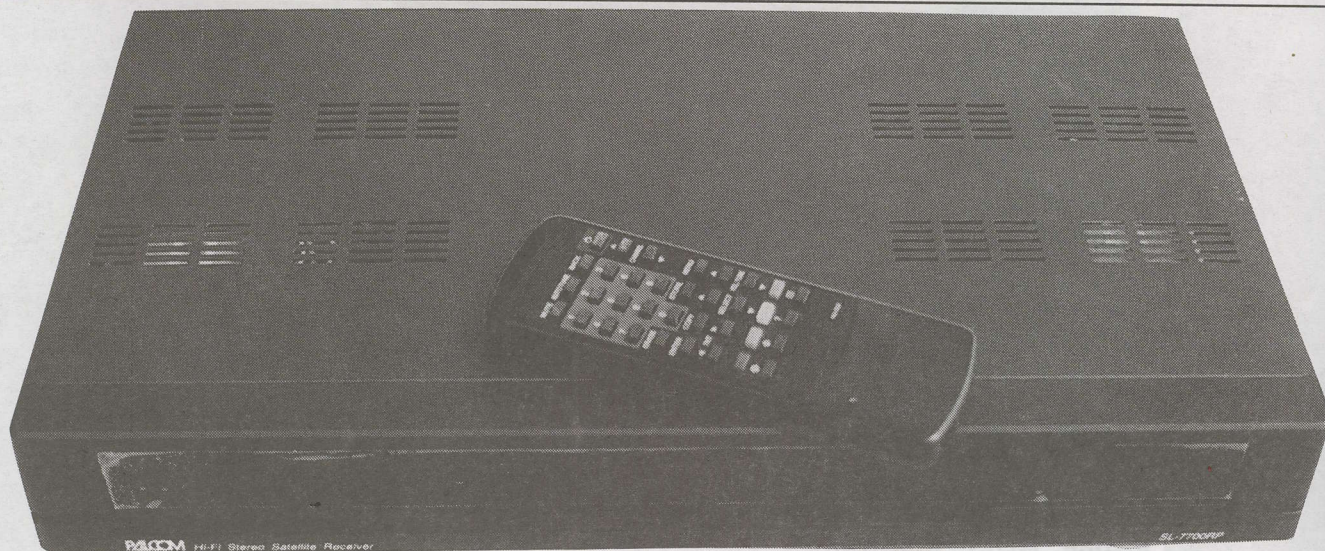





**THRESHOLD EXTENSION** - Real world, not theoretical. Before (left) and after (right). It is not the "number" of threshold extension "steps" you have available, but rather the performance that counts to the viewer.

as "low fidelity" on the screen. This leaves us with two meaningful tests for any receiver:

1) On below threshold signals, with threshold extension turned on, what happens to the original video quality as the receiver attempts to reduce or eliminate the "sparklies?"

2) On a high (fidelity) video image, how close to "studio perfect" reproduction does the receiver come?

The 7700, unlike the 7900, has a limited number of threshold extension "levels" available; 7 to be exact. What PALCOM appears to have done is to retain

numbers 1 and 32 from the original 32 in the 7900, and then select five other intermediate "steps" between the two extremes. As a practical, user, matter, numbers 1 through 5 will with varying results improve or greatly improve a below threshold analogue signal to the point you can watch the programming without being distracted by the artefacts left over from threshold extension. Numbers 6 and 7 work OK as long as there is no text on the screen, and, no concentrated very bright colours (such as a red ball appearing in the lower left corner of the screen - which in numbers 6 and 7 bleeds right to create a red blob across the full screen). Our experience with the 7900 was similar - 1 through 15-18 made the image enjoyable, numbers (15) 18-32 cleaned it up but only at the expense of creating new artefacts that were annoying to themselves.

The real world here is that threshold extension comes with a price; if you get beyond the first few steps and cannot watch the screen, going further will only clean up the image when the video content is very uniform over the full screen (and no text or graphics are present). The 7700 produces watchable images on transmissions other receivers cannot even detect. It turns a P1 image on wide bandwidth to a P3 image on threshold extension steps 3 or 4 or 5. Moreover, the range of audio bandwidths allow you to clean up otherwise scratchy audio producing the equivalent of P5 audio on a signal that had a P1 image before you put the receiver's special features to work.

The rear deck leaves nothing out. And all of those plugs and jacks and screw-on connections are internally software connected to an on screen menu system that allows the user to manipulate virtually any antenna or feed system known to man. Audio and video come out in RCA jacks (including baseband video for decoders) which is very thoughtful as not everyone has a SCART

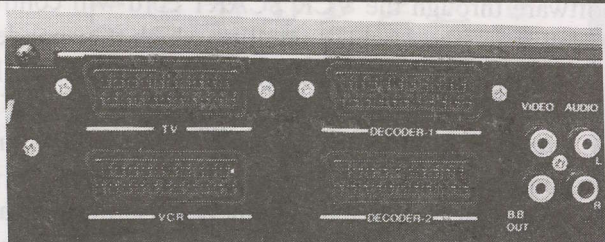

**IMPORTANT** - Four SCART outputs (TV, VCR and two analogue decoders), plus, RCA video, audio (L, R) and baseband output (to drive a decoder).

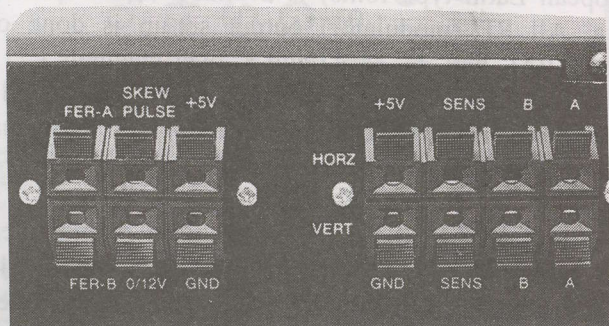

**MORE IMPORTANT** - twin motor drive connections (horizontal, vertical) coupled with "Autofocus" and "Autotune" scanning ranges allow the dish to automatically track and follow "floating" (inclined orbit) satellites without operator interface.



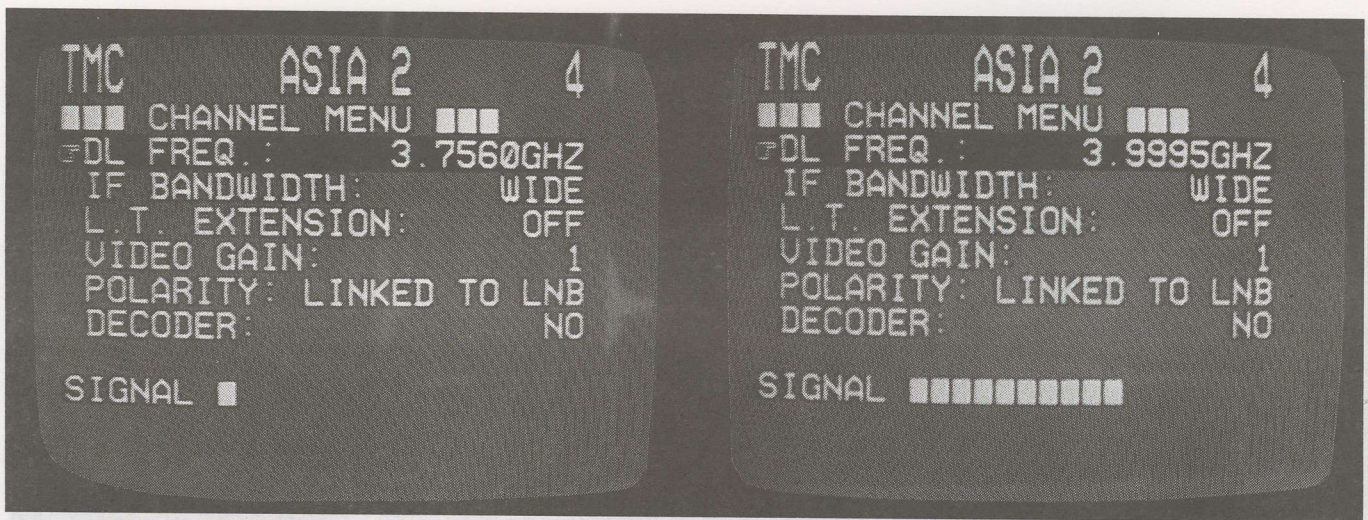

YES - You can locate the presence of digital signals with the SL-7700RP signal level meter. Left, AsiaSat 2 horizontal in one of the few "holes" where there is no analogue or digital signal (note bottom "signal" indication). Right, European Bouquet digital as it registers on receiver "S" meter.

cord handy. For those who do, there are four SCART connectors including two for analogue decoders.

#### Tracking Satellites

This is really cute and for as long as there are Russian Gorizont and ArabSat birds around (or others that are kept running with inclined orbit mechanics past their "destroy-by" dates - such as some Intelsats), this feature is worth the price of the receiver all alone. Included is a software driven "(inclined) timer." With it, the receiver starts up an autotune routine at intervals between 0 and 120 minutes. Whether the receiving system is being used or not, the routine turns on a signal monitoring circuit and this causes the dish drives to activate for a few steps either side of where they last came to rest as the receiver senses the amount of signal present. If either the horizontal (azimuth) or vertical (inclined orbit) actuator moves and the receiver finds *more* signal than it had at the start of the routine, the microprocessor in the receiver keeps the search going until the signal is peaked up. In other words, the dish keeps on tracking the "floating" satellite at all times correcting the dish

pointing for any bird movement. The same autotune software routine is built into the dish actuator for *normal* east - west dish movements. When you select a "go to" satellite from the memory locations stored in the receiver, the software tells the actuator to move. Arriving at the memorised satellite location, it then does a software "fine" (autofocus) tune. This means the dish always ends up *peaked* on the satellite even if something mechanical has changed at the dish (we all know actuator arms get sloppy, bearings get worn and this affects the accuracy of the dish mover mechanism).

#### Other Features

Software through the VCR SCART cord will control the satellite receiver (which satellite, which transponder, which audio and video settings) *and* an external VCR. You can tell the software to record something on As2 at 2PM, PAS-2 at 6PM and AsiaSat G (122E) at 9PM and come home to find them all neatly stacked up on VHS tape. The secret here is the extremely versatile software which loads into memory all of the parameters for every transponder you want to watch, recallable by date and time or by on screen menu selected in real time on command. *Teletext* (in Arabic, Hebrew, Cyrillic, European Latin type fonts) is available as an optional extra. All RF (modulator) output set-up is done on screen (PAL I, B, G, M, D and K over channels E21 - E69). There are 2 IF inputs (useful for a fixed dish and a motor drive dish or for orthomode feeds) with individual control over each through the menu.

#### Summary

PAL format high fidelity video from programmers who care to transmit first rate images is superb, the sound is studio quality. We have never seen better. NTSC and SECAM video are very good but this receiver is "peaked" for PAL use and, if anything this demonstrates vividly that NTSC, in fact, was always a second rate "standard" anyhow. Best of all, the SL-7700RP costs little more than a competitive receiver that does half the job. Availability? Bay Satellite, Satech and Skandia.

HARD to do justice to the absolute clarity and tone of the analogue picture - especially in black and white. CFI service (Palapa C2).





# The Most Advanced Free To Air Digital Satellite Receiver

## D7-MediaStar

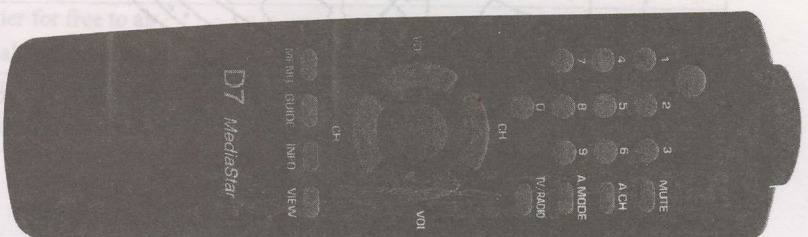
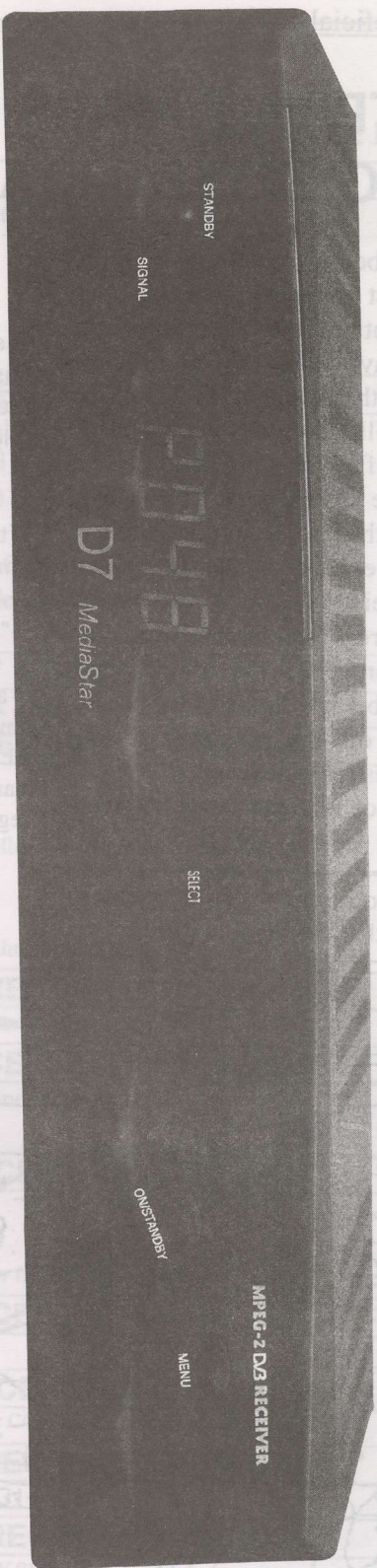

- MCPC/SCPC 2-36 Msym
- Direct channel selection from channel list
- Channel Edit menu Delete, Skip, ON.
- Fast response when changing channels
- No channel over-write
- 200 Video 100 Audio channels
- Automatic search and download
- 22 KHz switch

- PID Menu
- NTSC/PAL Auto switching NO NTSC Glitch
- NTSC converted to PAL-60Hz Free Option
- Audio L, R, Stereo selectable via remote control
- RF Modulator PAL-G, VCR/TV Scarts, RCA Audio/Video, SVHS outputs.
- 90-265VAC-50-60Hz power supply
- Low threshold performance

Opac Pty Ltd

99-105 Boundary Road

Peakhurst NSW 2210

E-mail [opac@bigpond.com](mailto:opac@bigpond.com)

Tel ++61 2 9584 1233

Fax ++61 2 9584 1452



## FOOTPRINT MAPS SUGGEST ALL THAT GLITTERS MAY NOT BE GOLD

Increasingly we are being required to form judgements concerning the best (smallest practical) dish size for successful digital reception. It is worth repeating that digital and analogue have one very significant difference for the installer: With analogue, if the picture is less than perfect, there is still a picture to watch (and sound to listen to), however flawed it might be. In a digital environment, when the IRD detects (through a simple "counting" process) that some predetermined "error" threshold has been exceeded, the processor simply shuts down. The receiver (IRD) is constantly monitoring the number of errors per "frame" (image) and when the error rate approaches 1% of the total amount of information being transmitted, the microprocessor simply shuts off the processor for as long as this predetermined threshold is exceeded.

You gain "margin" (difference in signal level between the threshold point and the actual signal from the

THAICOM 3 C-band global footprint from 78.5E; note most of Australia is within 35 dBw contour.

### What Size Dish?

Projected (prior to launch) footprint maps are seldom updated after launch and become general use reference sheets for the lifetime of a satellite even when post-launch indicates variations from the original paper "projection." If you know the eirp (on ground signal level in "dBw") you can quickly determine minimum dish size required.

After four years of digital experience, we now know that a spectrum analyser reading of approximately 6 dB for digital signal equals consumer grade "threshold" for a typical analogue receiver (7 dB C/NR). Below 6 dB of MPEG signal displayed on the analyser, you begin to have "tiling" (break up of video, images frozen on the screen briefly). This corresponds to a BER (bit error rate) in the region of 1.1/1.8 to -2. A suitable margin for consumer C-band digital exists with a BER in the region of 5.0 -3; Ku band digital should be in the -4 or even -5 region for freedom from dropouts during moderate rainfall. And all of this helps us determine dish size.

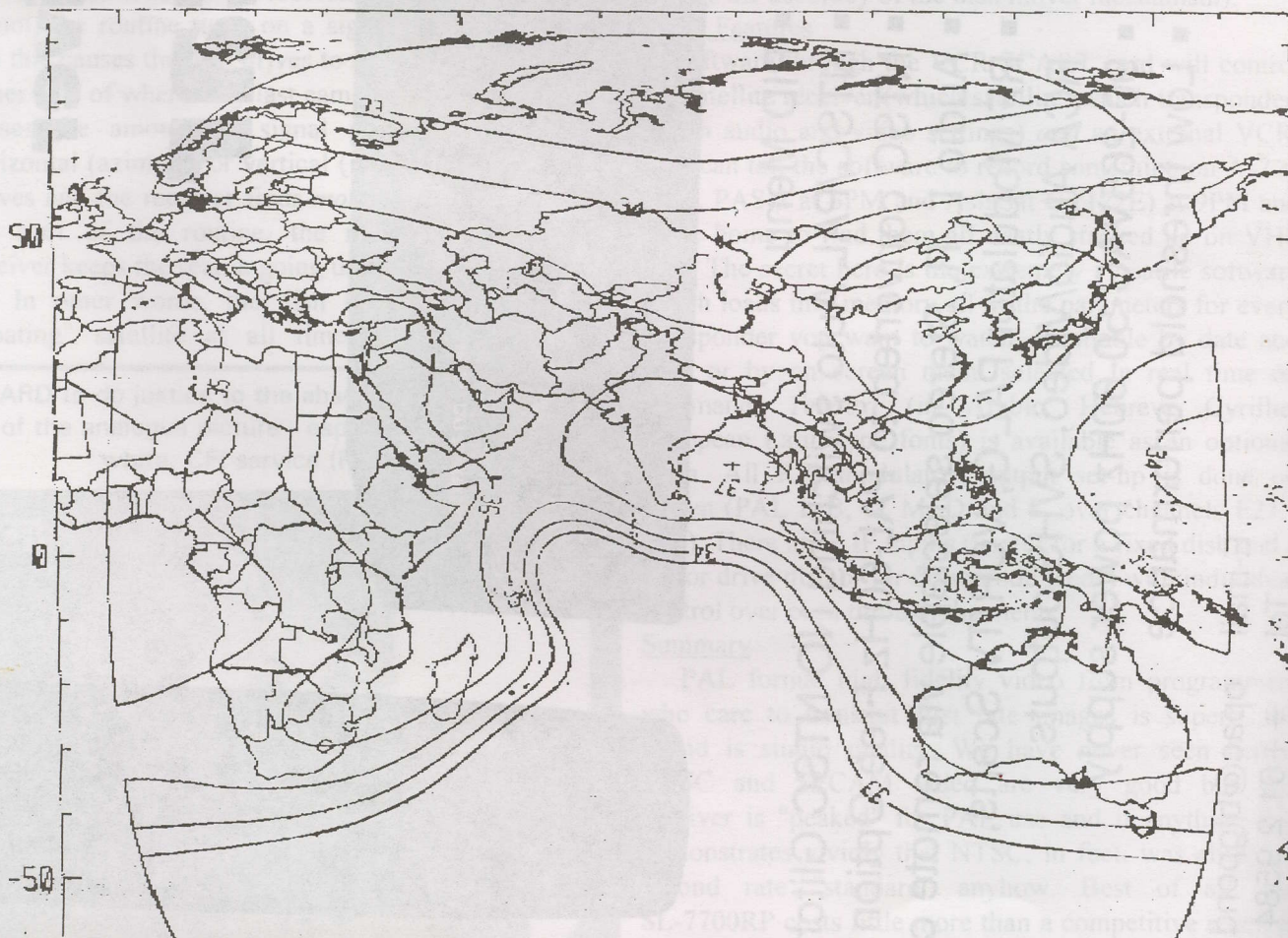





## SATELLITE RECEIVING EQUIPMENT

Part No.	Description	Price \$ each
<b>ACTUATORS</b>		
SAT1602	JARL-3612 12" s/jack	111.00
SAT1603	Venture-3618 18" s/jack	122.00
SAT1604	Venture-3624 24" s/jack	211.00
SAT1606	QARL 3036 36" s/jack	227.00
<b>FEEDHORNS</b>		
SAT1502	Chaparral polarotor C band, adjustable	86.00
SAT1506	Chaparral polarotor Ku C dual band corotor 2	195.00
SAT1507	Jonsa dual polarity C band (2 ports)	69.00
SAT1512	Golden ring	19.00
SAT1515	Feedhorn polarity adjustable scalar C band linear	29.00
SAT1516	Feedhorn circular polarity adjustable C band circular	51.00
SAT1518	Jonsa Ku band WR75 feedhorn	17.00
<b>BOOKS</b>		
SAT2200	The World of Satellite TV, by Mark Long	31.90
<b>PACE RECEIVERS - ANALOGUE</b>		
SAT1007	Pace MSS200 receiver	319.00
SAT1009	Pace MSS500 receiver with positioner	599.00
SAT1010	Pace MSS1000 receiver/positioner. Dolby Pro-Logic surround sound	541.00
SAT1012	Pace PSM8500 SMATV receiver	1,870.00
SAT1013	Pace MSS138G receiver	239.00
SAT1017	Pace MSS148GR, 250 channels. Low threshold receiver	296.00
<b>CHAPARRAL RECEIVERS - ANALOGUE</b>		
SAT1015	M140 full positioner. Includes inclined orbit operation, low threshold	1,800.00
<b>DRAKE RECEIVERS - ANALOGUE</b>		
SAT1002	Drake ESR2000XT receiver/positioner	1,372.80
SAT1016	Drake inclined orbit kit	146.00
<b>STRONG RECEIVERS - ANALOGUE</b>		
SAT1025	Strong SRT200 receiver	202.00
SAT1026	Strong SRT230 receiver - low threshold	234.00
SAT1027	Strong SRT1500LT MKII receiver - low threshold/positioner	627.00
<b>PALCOM RECEIVERS - ANALOGUE</b>		
SAT1040	RP7700 receiver/positioner	\$499.00
<b>PACE RECEIVERS - DIGITAL</b>		
SAT1014	DVS200 full DVB compliant digital receiver C/Ku band, polariser etc. Remote control	899.00
<b>HYUNDAI RECEIVERS - DIGITAL</b>		
SAT1024	Digital DBS set top box HSS-100C	726.00
<b>DIGISKAN RECEIVERS - DIGITAL</b>		
SAT1023	DigiSkan digital satellite receiver SK888	599.00
<b>NTL COMMERCIAL RECEIVERS</b>		
SAT1020	NTL professional MPEG-2 receiver/decoder for free to air	3,500.00
SAT1021	NTL professional MPEG-2 receiver for Galaxy compliance	3,500.00
<b>POSITIONERS</b>		
SAT1305	Pace positioner with polarizer control, mates to MSS248GR	190.00

Quantity discount, subject to negotiation  
 Prices exclude sales tax: 22% all items including digital receivers

Prices are subject to change without notice  
 Prices are ex-store Melbourne



Skandia Communications Pty Ltd

SatFACTS May 1998 ♦ page 11

Victoria: 183 Burwood Road Hawthorn 3122, Australia

Telephone: (03) 9819 2466 Fax: (03) 9819 4281

NSW: Level 1, 39 Terry Street, Rozelle 2039, Australia

Telephone: (02) 9555 2955 Fax: (02) 9555 2455

**SATELLITE**  
SPECIALISTS





## SATELLITE RECEIVING EQUIPMENT

Part No.	Description	Price \$ each
<b>DISHES – complete with mounting hardware</b>		
SAT1102	S60-1W 65cm offset pole mount	45.00
SAT1105	S120-1W 1.2M offset pole mount	169.00
SAT1116	P180-6W 1.8M 6 petal pole mount	179.00
SAT1120	S90-1W 90cm offset pole mount	105.00
SAT1121	P240 2.4M petal dish	345.00
<b>PARACLIPSE DISHES</b>		
SAT1154	1.2M (4ft) steel dish hydro A-Z mount	149.00
SAT1155	1.5M (5ft) steel dish hydro A-Z mount	221.00
SAT1140	1.5M (5 ft) hydro polar mount	233.00
SAT1153	1.8M (6ft) steel dish hydro A-Z mount	406.00
SAT1130	1.8M (6ft) hydro polar mount, aluminium dish	445.00
SAT1160	1.8M (6ft) steel dish hydro patio mount	399.00
SAT1138	2.4M (7.5ft) AZ-EL mount solid aluminium dish	879.00
SAT1131	2.4M (7.5ft) hydro polar mount, aluminium dish	916.00
SAT1156	2.4M (7.5ft) hydro aluminium dish H/H mount tracer 180°	1,336.00
SAT1134	2.6M (8.5ft) polar mount aluminium mesh dish. Eclipse	555.00
SAT1132	3.0M (10ft) polar mount aluminium mesh dish. Eclipse	924.00
SAT1159	3.1M Patriot A-Z mount <b>commercial</b> antenna	2,227.00
SAT1135	3.1M Patriot polar mount dish	2,227.00
To be advised	3.7M (12ft) Patriot solid <b>commercial</b> antenna	P.O.A.
SAT1137	3.7M (12ft) H/H mount mesh aluminium dish	1,886.00
SAT1170	3.7M (12ft) Classic polar mount aluminium dish	2,763.00
SAT1133	3.7M (12ft) polar mount aluminium mesh dish. Eclipse	1,216.00
To be advised	4.5M (14.5ft) Patriot solid <b>commercial</b> antenna	P.O.A.
SAT1136	4.5M (14.5ft) polar mount aluminium dish. Islander	2,871.00
SAT1157	4.8M (16ft) Classic H/H aluminium dish mount	12,029.00
<b>ACCESSORIES FOR PARACLIPSE DISHES</b>		
CRATE185x185x380	Packing crate 1.8M satellite dish	90.00
CRA2460x2460x500	Packing crate 2.4M satellite dish	150.00
CR135X135X30	Crate, pine for 1.2M satellite dish	75.00
CR165x165x35	Crate, pine for 1.5M satellite dish	85.00
SAT1150	Kit, stainless steel for 1.8M dish	109.00
SAT1151	Kit, inclined orbit 3.7M (12ft.)	57.00
SAT1152	Hydro Ku band adapter kits for all dishes	25.00
SAT1171	Locking bar replaces actuator on polar mount	19.00
<b>LNBS</b>		
SAT1401	Ku 1.0dB typical offset LNBF voltage switching ORITRON (Cambridge for Galaxy)	59.00
SAT1402	LNBF 25K C band Voltage Switching CalAmp	120.00
SAT1403	LNB 20K C band digital extended	79.00
SAT1415	LNB .7dB to suit Ku band	89.00
SAT1417	Combined LNBF/polarizer C band 20°K Chaparral Micropak	99.00
SAT1418	LNB Minimag C band 25K	77.00
SAT1419	LNB Minimag CalAmp C band digital 25K	120.00
SAT1424	Ku band prime & offset 0.9dB LNBF CalAmp Galaxy voltage switching	109.00
SAT1426	Gardiner C band 17K extended bandwidth	95.00
SAT1427	Chaparral 20K vision C band voltage switching LNBF	109.00

Quantity discount, subject to negotiation  
Prices exclude sales tax: 22% all items including digital receivers

SatFACTS May 1998 ♦ page 12

Prices are subject to change without notice  
Prices are ex-store Melbourne



Free to Air

**Skandia**

Skandia Communications Pty Ltd

**SATELLITE**  
SPECIALISTS

Victoria: 183 Burwood Road Hawthorn 3122, Australia

Telephone: (03) 9819 2466

Fax: (03) 9819 4281

NSW: Level 1, 39 Terry Street, Rozelle 2039, Australia

Telephone: (02) 9555 2955

Fax: (02) 9555 2455



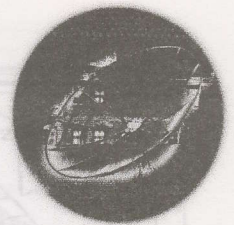

## SATELLITE RECEIVING EQUIPMENT

Part No.	Description	Price \$ each
<b>SPLITTERS</b>		
SAT1800	2W CHY satellite splitter SS202P power pass 2 legs	6.00
SAT1801	4W CHY satellite splitter SS204P power pass 4 legs	10.00
SAT1802	4W satellite splitter PS104 non-power pass	19.00
SAT1805	3W CHY satellite splitter SS203P power pass all legs	8.00
<b>SATELLITE TEST EQUIPMENT</b>		
SAT2100	SF90 satellite finder	48.00
5680	SAM951 satellite field strength meter	2,149.00
5754	SAM945B satellite field strength meter	1,067.36
5762	SAM361 satellite finder with tone	124.88
5777	APM340 cable and field strength analyser. Hand held	1,524.24
5785	APM381 combined SAT/TV MMDS field strength meter	1,250.00
5788	APM746 satellite field strength meter	7,600.00
<b>TOOLS</b>		
A2051H	Crimper 0.360/0.324 hex sizes for RG6, RG59	26.00
A2052	Coax stripper RG6, RG59	12.00
SAT3000	Crimp repair kit	7.00
SAT3001	Hex crimp 0.475 & 0.360 & 0.96 hex sizes for, RG6, RG11, RG59	73.00
SAT3002	Ripley stripper DT596 for RG6, RG59	10.50
SAT3003	Universal drop trimmer for RG6, RG11, RG59USA	73.00
SAT3004	Replacement blades to suit Universal drop trimmer RG59	13.00
SAT3005	Replacement blades to suit Universal drop trimmer RG11	10.50
<b>COMPASS</b>		
SAT2500	Silva satellite compass	36.00
<b>DECODERS/MODULATORS</b>		
SAT2301	Epal decoder	299.00
SAT2304	CN100P system converter, NTSC to PAL analogue	98.00
SAT2305	CDM600 NTSC Secam to PAL digital system converter	498.00
SAT2306	Teletext Epal decoder	590.00
<b>SATELLITE ACCESSORIES</b>		
SAT1180	Pole 60mm O.D. 3.25M long	45.40
SAT1181	Pole 89mm O.D. 3.25M long	71.60
SAT1182	Quick set concrete, 20kgs.	7.48
SAT1183	Quick set concrete, 40kgs.	11.00
<b>UNIVERSAL REMOTE CONTROLS</b>		
BW-5023	Universal remote control, Remote Master 350	25.00
BW-0200	Universal remote control, Remote Master 350 plus	32.00
BW-6010	Universal remote control, Remote Master 1000	48.00
BW-6020	Universal remote control, Remote Master 2000 with LCD display	69.00

**PRICES ARE NEGOTIABLE FOR QUANTITIES - (03) 9819 2466**

Quantity discount, subject to negotiation  
 Prices exclude sales tax: 22% all items including digital receivers

Prices are subject to change without notice  
 Prices are ex-store Melbourne



Free to Air

**Skandia**

**SATELLITE**  
**SPECIALISTS**

Skandia Communications Pty Ltd

Victoria: 183 Burwood Road Hawthorn 3122, Australia

NSW: Level 1, 39 Terry Street, Rozelle 2039, Australia

SatFACTS May 1998 • page 13

Telephone: (03) 9819 2466 Fax: (03) 9819 4281

Telephone: (02) 9555 2955 Fax: (02) 9555 2455



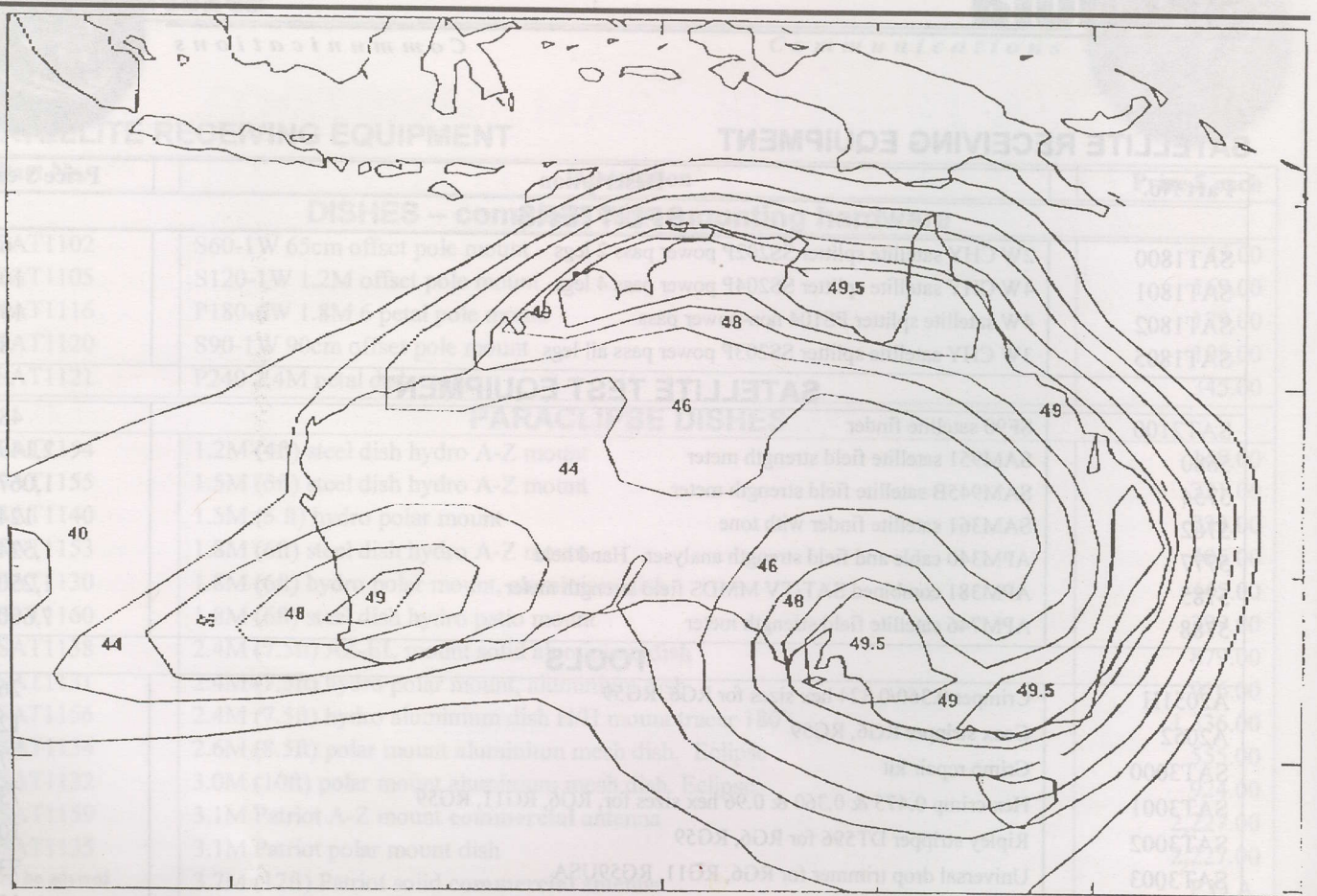

PanAmSat PAS-8 "Proprietary" projected coverage from 166E, Ku band. PAS-8 does **NOT** have any projected Ku-band coverage to New Zealand nor east of Australia except as shown here.

dish/LNB) by increasing the signal input to the feed at the dish. You improve the margin by (1) getting more dish gain, (2) lowering the LNB(F) noise temperature. And you achieve more dish gain by (1) Increasing the size of the dish, (2) improving the efficiency of the feed antenna connected to the LNB and "looking at" the dish.

Not all digital transmissions are created equal and those with FEC (forward error correction) in the 1/2, 2/3

and 3/4 region are more "robust" (capable of standing up and not being lost to low threshold drop out) as those that use an FEC of 7/8. Assuming your spectrum analyser displays digital signals with reasonable trueness, those that have badly slanted tops or jagged appearing top lines will be more prone to dropping out (i.e., BER exceeds established minimum) than waveforms that have nice, straight and even top displays

**Ku Band Digital Requirements assuming normal dish efficiency, 1.2 dB LNB(F), FEC in 1/2 to 3/4 region**

Footprint Level	Dish Size for Threshold	3 dB Margin	6 dB Margin
33 dBw	3m	4m	5.8m
34 dBw	2.7m	3.6m	5.1m
35 dBw	2.4m	3.2m	4.5m
36 dBw	2.1m	2.8m	4m
37 dBw	1.8m	2.4m	3.6m
38 dBw	1.65m	2.25m	3.3m
39 dBw	1.5m	2.1m	3.1m
40 dBw	1.35m	1.95m	2.8m
41 dBw	1.2m	1.8m	2.5m
42 dBw	1.12m	1.61m	2.2m

Footprint Level	Dish Size for Threshold	3 dB Margin	6 dB Margin
43 dBw	1.05m	1.45m	2.0m
44 dBw	0.95m	1.30m	1.8m
45 dBw	0.85m	1.16m	1.6m
46 dBw	0.73m	1.03m	1.4m
47 dBw	0.62m	0.9m	1.2m
48 dBw	0.56m	0.82m	1.1m
49 dBw	0.50m	0.75m	1.0m
50 dBw	0.45m	0.68m	0.90m
51 dBw	0.39m	0.60m	0.80m
52 dBw	0.34m	0.52m	0.70m
53 dBw	0.3m	0.45m	0.62m



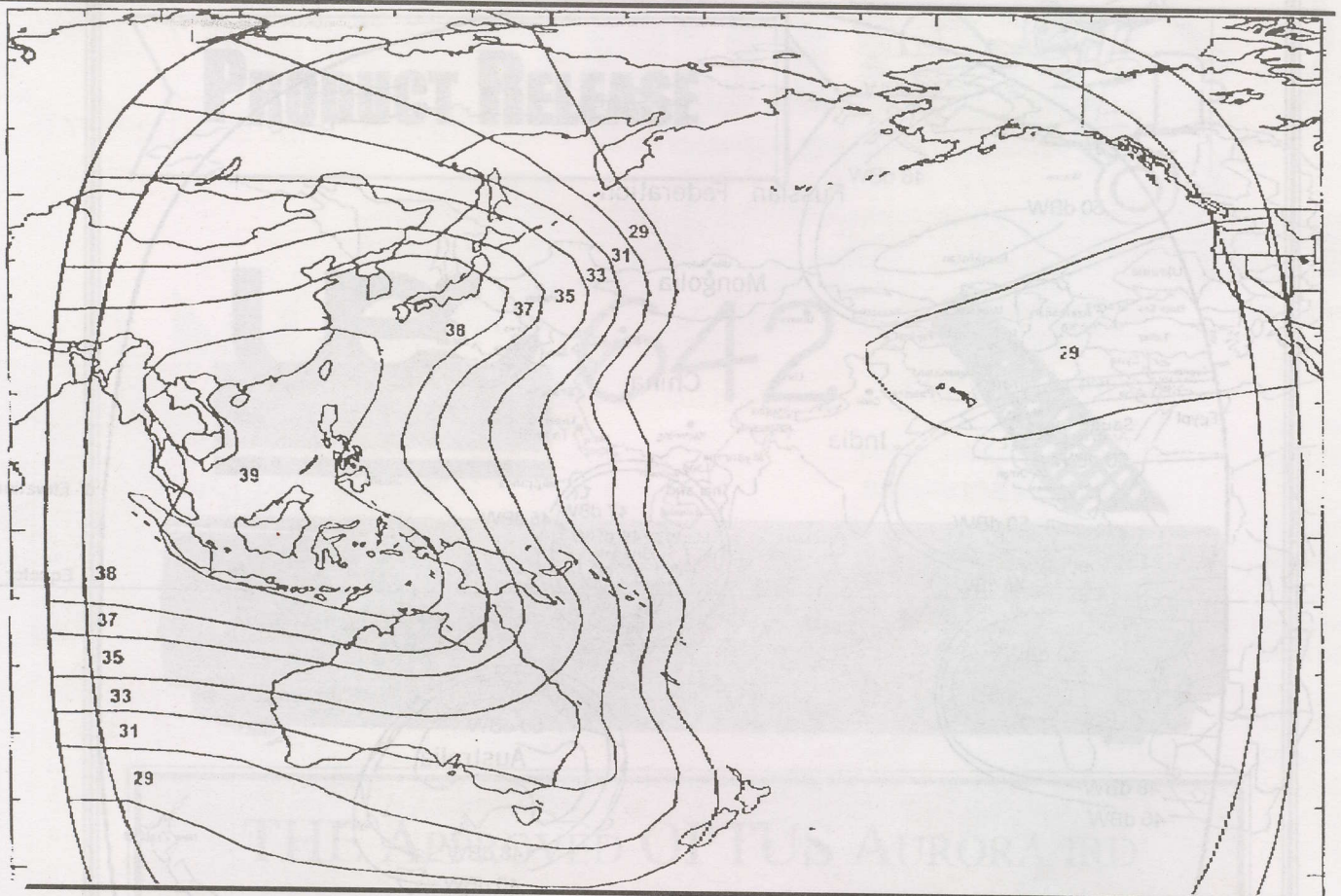

PanAmSat PAS-8 "Proprietary" projected C-band coverage from 166E on horizontal transponders. Note levels are several dB lower than PAS-2 for New Zealand and the Pacific Islands region.

(examples are shown on p. 16). In the final analysis, at each receiving site, how well the IRD decodes and displays the (MCPC) bouquet may be out of the hands of the receive system installer because of transmission point sloppy control of "bandwidth dynamics."

SCPC signals present unique challenges. For stable SCPC reception, the LNB(F) must have very tight control over its conversion frequency stability. An MCPC (multiple channel) bouquet is wide enough in

bandwidth that the IRD can tolerate some "frequency drift" at the LNB down conversion point to IF. An SCPC signal is so "bandwidth (frequency) narrow" that LNB frequency drift can cause the signal to fall outside of the IRD's tuning range, causing momentary or extended period reception dropout. SCPC installations usually require higher stability LNB(F)s to protect against frequency drift causing signal dropout. The narrower the SCPC signal, the higher the stability required.

**C-band Digital Requirements assuming normal dish efficiency, 20 degree LNB, FEC in 1/2 to 3/4 region**

Footprint Level	Dish Size for Threshold	3 dB Margin	6 dB Margin
21 dBw	7.6m		
22 dBw	7.2m	10m	
23 dBw	6.4m	8.1m	
24 dBw	5.8m	7.6m	
25 dBw	5.2m	6.8m	10m
26 dBw	4.6m	6m	8.1m
27 dBw	3.9m	5.4m	7.6m
28 dBw	3.4m	4.8m	6.8m
29 dBw	3m	4.3m	6m
30 dbw	2.7m	3.9m	5.3m

Footprint Level	Dish Size for Threshold	3 dB Margin	6 dB Margin
31 dBw	2.4m	3.5m	4.8m
32 dBw	2.2m	3m	4.3m
33 dBw	2m	2.7m	3.9m
34 dBw	1.8m	2.4m	3.5m
35 dBw	1.6m	2.1m	3m
36 dBw	1.4m	1.9m	2.7m
37 dBw	1.2m	1.7m	2.4m
38 dBw	1.2m	1.5m	2.2m
39 dBw	1.0m	1.35m	1.9m
40 dBw	0.9m	1.2m	1.7m



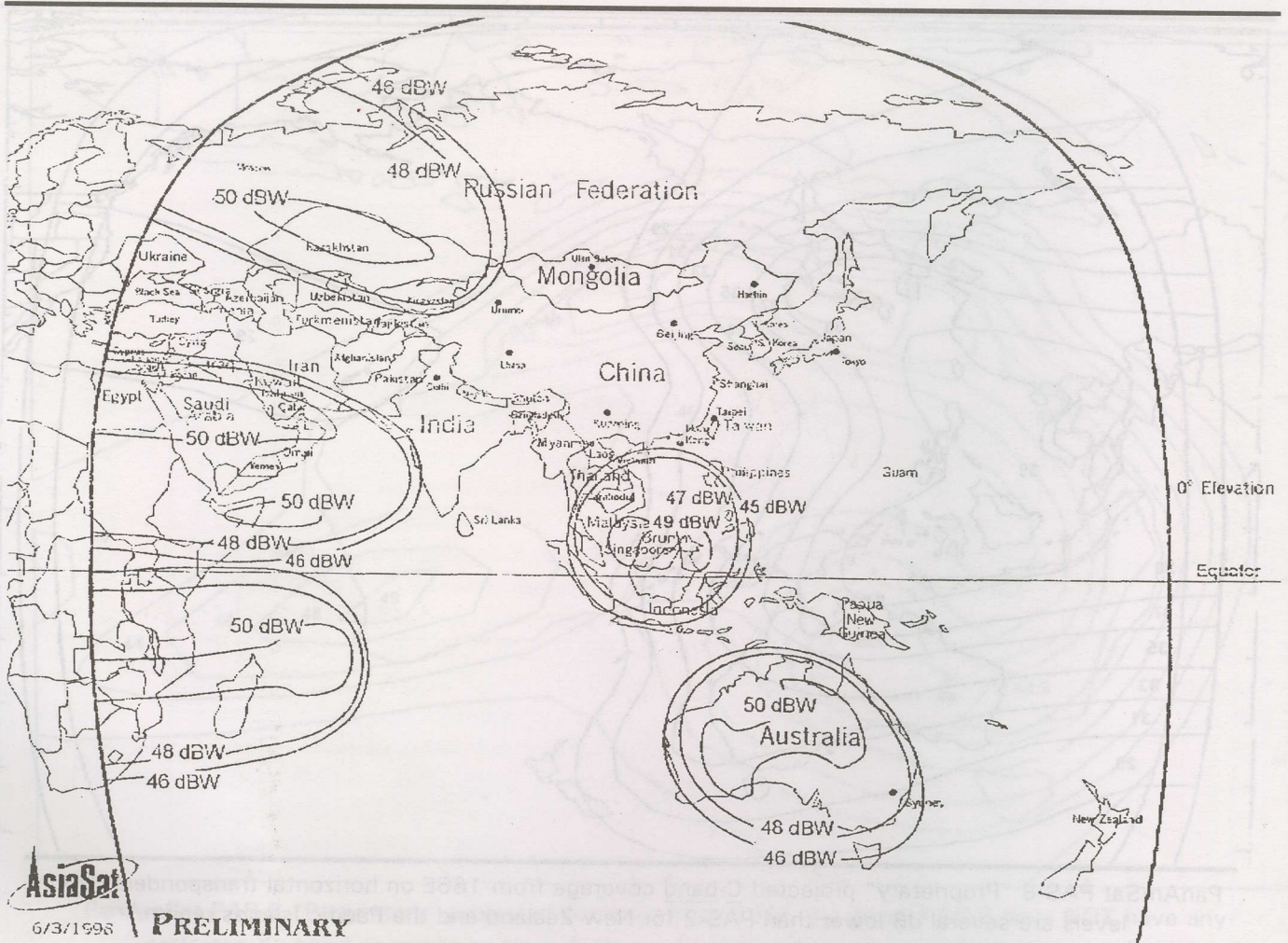

6/3/1998

**PRELIMINARY**

AsiaSat 3 projected steerable Ku-band coverage from 105.5E. Note only **ONE** of these can in fact operate at a time. Satellite is flexible as to which beam will be used, but only one of those shown is possible.

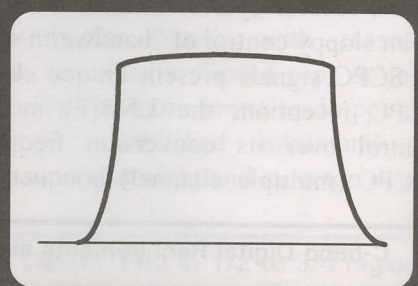
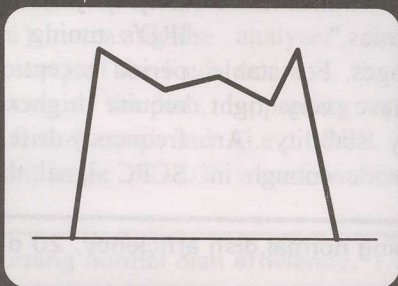
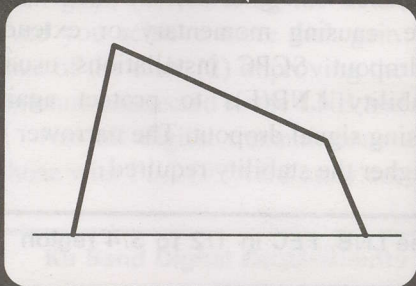

THREE examples of spectrum analyser MPEG waveforms. Left, sloping top indicates poorly controlled compression dynamics favouring low end of (MCPC) multiplex. Middle has similar lack of dynamic balance over (MCPC) bandwidth. On right, evenly balanced, well operated (MCPC) bouquet with evenly distributed compression rates. Proper receiver operation depends upon good control of transmission dynamics.

### small, medium and LARGE C and Ku antennas in stock!

Transmit and receive antennas from 1.2m to 13m (Intelsat Standard B). Linear and circular feeds (AsiaSat, Palapa, JcSat, Rimsat, PanAmSat, Intelsat and more) for transmit and receive-only applications. Receive and transmit electronics including inclined orbit tracking equipment with motor drives for elevation and azimuth to 50 tons. Complete system design, fabrication, installation + proof of performance.

P  
A  
C  
I  
F  
I  
C



Limited

A  
N  
T  
E  
N  
N  
A  
S



# PRODUCT RELEASE

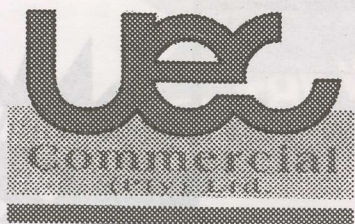

# 642

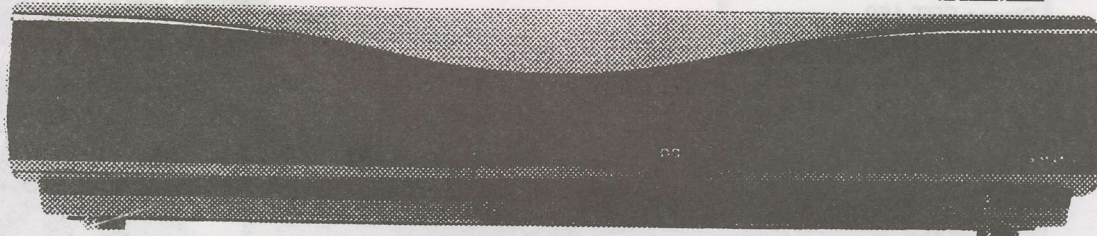
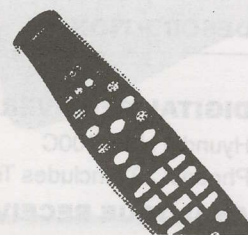

## THE APPROVED OPTUS AURORA IRD AUSTRALIAN DISTRIBUTOR NATIONWIDE ANTENNA SYSTEMS

17 Campbell Street, Bowen Hills, Qld 4006

Approximate dish size required. Including generous allowance for rain fade.

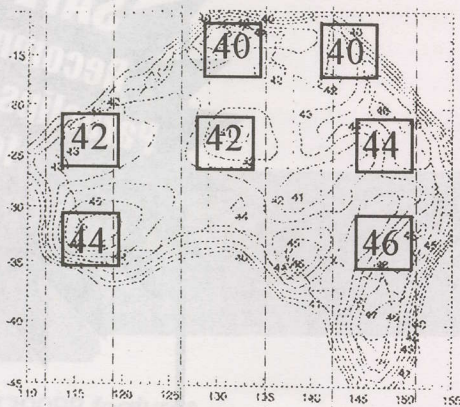

40	40 dBw	2.4m
42	41-42 dBw	1.5m
44	43-44 dBw	1.2m
46	45-47 dBw	0.90m

EMAIL



experts@uq.net.au

Order Hotline



+07 3252 2947



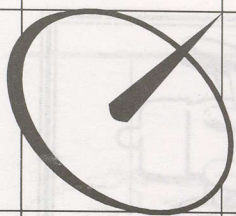

# SATECH

Satellite Communication Technology Pty. Ltd.

## SATECH PRODUCT RANGE

### PART NO.

### DESCRIPTION

#### DIGITAL RECEIVERS

- SC1001 Hyundai HSS-100C  
SC1002 Phoenix 222 includes Teletext

#### ANALOGUE RECEIVERS

- SC2001 Strong SRT 150  
SC2002 Strong SRT 700  
SC2003 Strong SRT 1500 W/Positioner  
SC2004 Strong SRT 7000 W/Positioner  
SC2005 Palcom SL - 7700 with Dual Positioner

#### LNB'S

- SC3001 KO22 KU Band WR-75 0.7db LNB  
SC3002 K012 KU Band 0.8db LNBF offset Voltage switching  
SC3003 Gardiner 17K C-Band Digital Extended  
SC3004 Chaparral 20K C-Band LNBF Vision Voltage Switching Digital Extended  
SC3005 Gardiner 20K C-Band Digital Extended

#### FEEDHORNS

- SC4001 Single KU-Band Feedhorn Prime Focus WR-75  
SC4002 C-Band Feedhorn with Polariser Prime Focus  
SC4003 Dual C-Band Feedhorn Prime Focus (ORTHO FEED)  
SC4004 Single C-Band Feedhorn Prime Focus

#### PARACLIPSE U.S.A. DISHES

- SC5001 1.5M Hydro Steel AZEL Mount  
SC5002 1.8M Hydro Steel Polar Mount  
SC5003 2.3M Hydro Polar Mount  
SC5004 2.6M Mesh Polar Mount  
SC5005 3.0M Mesh Polar Mount  
SC5006 3.7M Mesh Polar Mount  
SC5008 1.2M Hydro Steel AZEL Mount  
SC5011 1.8M Hydro Steel AZEL Mount  
SC5007 KU Band Feed Plate

#### U.S.A. VENTURE ACTUATORS

- SC6001 18" Venture Actuators  
SC6002 24" Venture Actuators  
SC6003 36" Venture Actuators  
SC6004 Dish Positioner

#### INSTRUMENTS

- SC7001 Satellite Finder with tone

#### DECODERS

- SC8001 Epal Decoder  
SC8002 System Converter - Digital NTSC, Secam to PAL  
SC8003 System Converter - Analog NTSC to PAL



#### All products available through the following SATECH Distributors:-

Southern Satellite - South Australia -Tel: 618 377 0955

Norsat - Western Australia -Tel: 618 9451 8300

Network Satellite Services - NSW -Tel: 612 9687 9903

Bay Satellite - NZ -Tel: 64 6 843 5296

Pacific Satellite - Queensland -Tel: 617 3344 3883

Satech - Victoria -Tel: 613 9553 3399



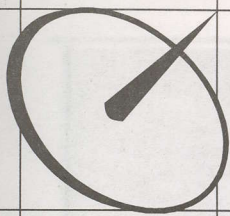

# SATECH

Satellite Communication Technology Pty. Ltd.

## Introducing

# THE WINNING COMBINATION

**NEW**  
with  
**Teletext**



**Phoenix 222**

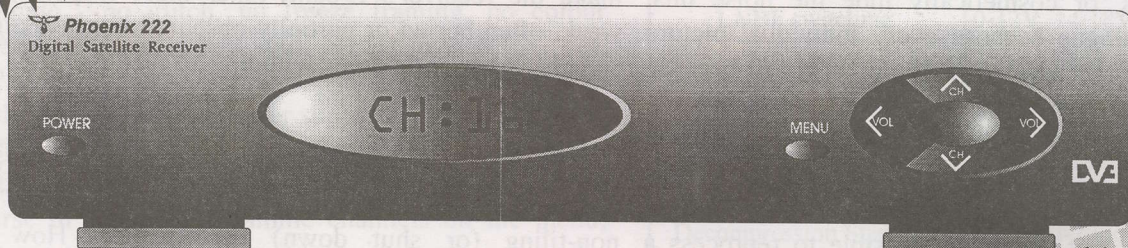

### Phoenix 222 features

- Super sensitive tuner
- 1500 TV Channels
- 1370 Radio Channels
- 50 Satellites
- Auto installation
- Teletext
- On screen signal strength meter
- C + KU Band
- Auto Channel Search
- 0/12 volt Switch
- 4.3 16.9 Aspect with Pan and Scan
- Full Software Controlled TV Modulator with Channel Selection PAL D/K B/G I
- Upgraded Software down loadable from Internet via RS232C

• Power Vu  
• DVB  
• Teletext on TV5

**No. 1**  
**Choice**

**PALCOM**

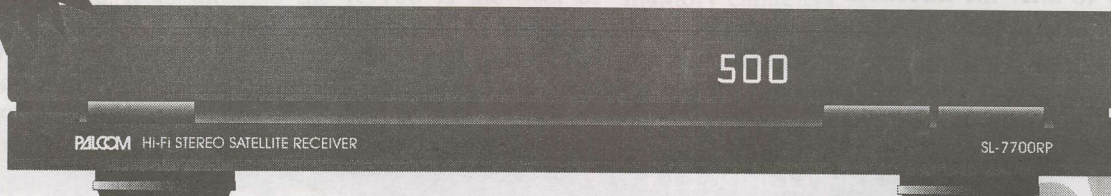

### PALCOM SL-7700RP features

- Dual Axis
- Positioner
- Low Threshold
- Auto Focus
- Inclined Orbit Tracking

See Review on  
**Palcom SL7700RP**  
this issue



Sole distributor for Phoenix Worldwide



# SATECH

Satellite Communication Technology Pty. Ltd.

SatFACTS May 1998 • page 19

6/477 Warrigal Road Moorabbin East Victoria Australia 3189 Ph: 613 9553 3399 Fax: 613 9553 3393



## AV-COMM R3100 MPEG-2 RECEIVER UPS THE ANTE

From the first MPEG receiver test published in SatFACTS (General Instrument DSR-1500; February 1995, SatFACTS # 5) to the present, one measurement above all others has served as a reference point for receiver tests. That measurement is "tuner sensitivity."

In the analogue world, there is threshold extension; the ability of a receiver to take a signal that is "below threshold" and somehow turn it into a better looking picture than with "TE" (threshold extension) turned off. Threshold extension, the reprocessing of a once processed signal to attempt to remove noise bits from the picture bits, or cosmetically hide the noise bits, works with analogue because every individual picture element (pixel) stands by itself. If a pixel is lost because of noise or interference, its loss does not in any way effect the still healthy pixels that surround the missing "bit."

There is no such thing as threshold extension in digital. In theory, it would be possible to reprocess a digital image a second (and even third) time to replace failed pixels with information stored from previously processed "frames" and in fact in normal digital reception a certain amount of this happens anyway. But built into every MPEG-2 receiver is a "pixel counter" operated by a microprocessor that is constantly checking to see how many pixels have been lost (covered by noise, degraded or distorted). Inside of the "counter" circuit is an "alarm" and switch. And built into the processing software is an electronic trip hammer that automatically stops processing the picture if the number of lost pixels rises above a pre-set level (of approximately 1% of the total pixels processed).

The only way to alter the threshold point in this type of processing system is to accept more than 1% total errors and allow them to accumulate on the screen. Lost information is the random appearance of "tiles" (briefly static squares on the screen when a signal approaches

threshold for that receiver). You could set up the software processing the pixels to allow 2% or even 5% of the pixels to be lost, but what you would get by doing this is simply more tiling (unpleasant looking square tiles on the screen) before the image once again failed because the trip hammer said "Shut it down - there are too many errors here to process."

The bottom line here is that if you are waiting for the first IRD designer to advertise he has "Digital TE," you could have a very long wait. While you are waiting, IRD sensitivity will come in small bites as designers learn to make the receiver's L-band tuner more responsive to weak, often buried or partially obscured in noise digital signals play properly without exceeding the trip hammer's switch off point.

Tuner sensitivity is a major (but not the only) consideration in determining an IRD's "threshold" for non-tiling (or shut down) performance. How the software people integrate the MPEG decoding functions, after the tuner, is equally important and the two go hand in hand (as recent unfortunate experience with the Hyundai version 5 software plus tuner change out has taught us). R3100 graphics allow you to monitor digital signal strength and signal to noise ratio. Our testing included loading all of the troublesome bouquets (EMTV, Hallmark, RAI/ART) to evaluate performance. With our reference-standard Nokia 9600 (version 5) running on the same bouquet at the same time, we compared the R3100 ability to grab and hold onto these troublesome services while purposefully degrading the signal by nudging the dish off the satellite. In every test, the R3100 lost the digital signal *after* the Nokia, and in returning to the satellite found it again *before* the Nokia. The Nokia has been our reference standard because it has consistently beat all other receivers in the same test. Analysis? The R3100 is the *most sensitive* MPEG-2

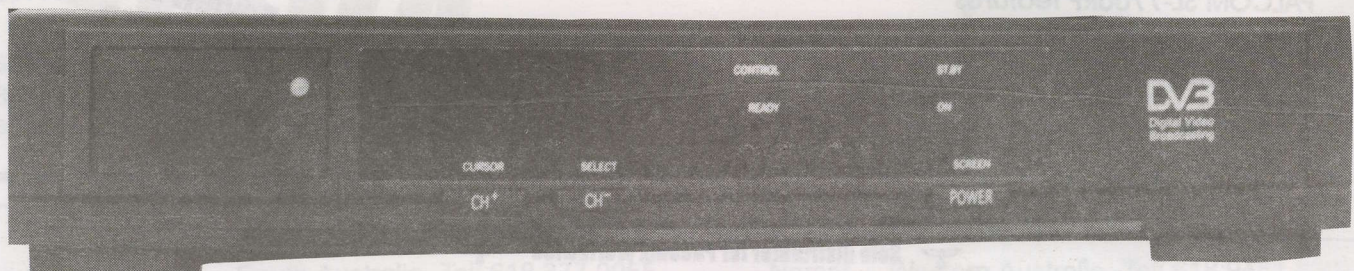



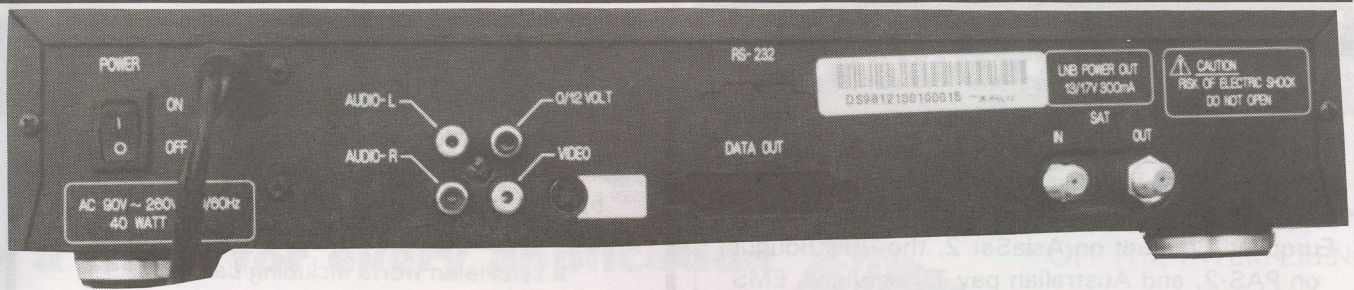

No frills back deck simplifies interconnection decisions. 14/18 volt, 22 kHz tone LNB switching allows selection of opposing polarities or different dishes from on screen menu. S-VHS output is a nice touch for component video feed to TV set (important for near-digital performance on analogue TV receivers).

FTA digital receiver we have had on our bench for test and evaluation, by 0.6 dB.

The menu entry, set-up and use is as good as the best we have previously seen. We found the MediaStar D7 "superior" in ease of use in previous tests (SF#43, p. 18) and rate the R3100 as equal to the D7. NTSC? Dial up any of the California bouquet NTSC services on PAS-2 and bingo - no glitch, no freeze framing, no colour problems. PAL in is PAL out, NTSC in is NTSC out. Heat? after a week's operation, the case remains cool to slightly warm (over the power supply at right rear).

When watching a programme channel you can bring up either that bouquet's programme channels or the full universe of loaded programme channels on the menu, select one and go directly to it (provided only it is on the same satellite [and polarity unless you are using a voltage switching LNB]). Switching time? Instant.

Loading the menu is done bouquet by bouquet. You need to know the frequency, (polarity), and symbol rate as a minimum. Once entered, the R3100 loads the full bouquet, lists the programme channels on the screen and adds them to the menu for later selection. The receiver has room for 64 bouquets and 256 programme channels in memory. Using multiple dishes, we had no difficulty switching instantly between AsiaSat 2 and PAS-2 simply by selecting the appropriate memory programme channels.

For marginal installations requiring maximum sensitivity, our tests indicate the R3100 is the best of

Input Frequency Range	950 - 2150 MHz
L-band connections	Input, loop thru output
FEC detection	automatic 1/2 - 7/8; (automatic Reed Solomon)
Symbol Rate Range	1 - 45 Mbps
Memory Capacity	64 bouquets, 256 channels
LNBF switching	0-12V, 14/18V, 22 kHz tone
LNB Voltage	14 or 18 VDC
Audio Connectors	RCA stereo, mono, reverse
Video Connection	RCA
S-Video	Multipin
Decompression Standard	MPEG-2 video, MPEG-1 audio
Video Format	Supports PAL, NTSC
Technical Aids	On screen signal level, signal to noise ratio
Mains operating voltage	90-260VAC, 46-63 hertz
Suggested Retail Price	A\$950 export, A\$1145 with sales tax inside Australia
Master Distributor	AV-COMM Pty Ltd. tel ++61-2-9949-7417 fax ++61-2-9949-7095

any receiver currently available. Negative: It lacks an RF modulator and some might wish there was additional memory capacity.

Set-up menu is straight forward, quick to use, and loads new bouquets in typically under 5 seconds time. On screen bouquet listings are available at touch of remote button (right).

**SATELLITE SETUP MENU**

Channel Set 37 ↔ 0.9

Channel Name HALLMARK

Channel Freq 3940 ← 0.9

Polarity H ↔

Symbol Rate 26665 ← 0.9

LNB Freq 5150 ↔ 0.9

22KHz Tone OFF ↔

0/12 volt 0 ↔

**Enter to Search**

**Program List**

- ▶ 113 HALLMARK
- ▶ 114 KIBC
- ▶ 115 Gateway1
- ▶ 116 Gateway2
- ▶ 117 Gateway3
- ▶ 118 Multicast

**Use ↑↓↔ ENTER EXIT Key**

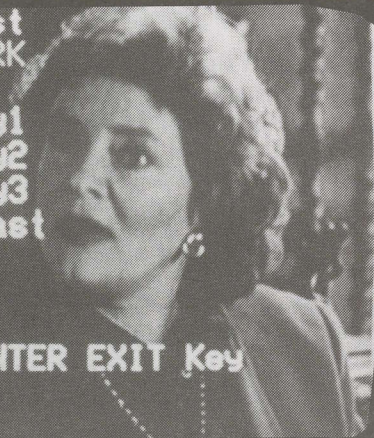



## MPEG-2 DIGITAL RECEIVERS - A\$375!!

We have sourced a batch of "surplus to requirements" MPEG satellite receivers. These receivers are as new, complete with all cables, remote control and instructions. These units cover 18 - 30 Msymbols making them suitable for the European Bouquet on AsiaSat 2, the NBC Bouquet on PAS-2, and Australian pay TV services. EMS shipping to NZ is available for A\$54, airmail A\$33.  
**Cat # R3000 Specifications / Frequency Range: 950 - 2150 MHz; Tuning Steps: 150 kHz; SR range: 18 to 30 Msym; FEC: 1/2, 2/3, 3/4, 5/6 and 7/8; IF bandwidth: 36 MHz; Modulator: UHF; Irdeto Conditional Access -CA module and smart card NOT included.**

YES GARRY

Please ship me \_\_\_ R3000 MPEG receivers @ A\$375ea  
 + A\$54 EMS or A\$33 Airmail (A\$ only) Credit card #  
 \_\_\_\_\_ - \_\_\_\_\_ - \_\_\_\_\_ - \_\_\_\_\_ exp \_\_\_ / \_\_\_

Signature \_\_\_\_\_

Name \_\_\_\_\_

Delivery address \_\_\_\_\_

P/code \_\_\_\_\_ Telephone \_\_\_\_\_

### AV-COMM PTY LTD

(ACN 002 174 478)

198 Condamino Street, Balgowlah NSW 093 Australia

Tel: 61-2-9949-7417 Fax 61-2-9949-7095

## ADVERTISING IN SatFACTS

SatFACTS, the official journal of **SPACE Pacific** (trade association) and now read in more than 60 countries throughout the Pacific, Asia and the balance of the world, accepts display space advertising targeting all aspects of the satellite television world including cable TV.

Advertising rate sheet explaining deadlines, charges for display space advertising, preparation of advertising layouts for publication in SatFACTS is available by telephoning 64-9-406-0651 or faxing 64-9-406-1083.

### Closing dates for advertising in upcoming issues:

Issue	Reserve space by	Copy due before
June 1998	May 29, 1998	June 4, 1998
July 1998	June 30, 1998	July 3, 1998
August 1998	July 31, 1998	August 3, 1998
September 1998	August 28, 1998	September 2, 1998

# SMART CALL SYSTEMS

*When satellite system sales are down, and you are looking for a solid business to keep your doors open - here is a totally unique, state-of-the-art telecommunications field with no competition and unlimited sales opportunity!*

## SMART CALL SYSTEMS

The ultimate in European technology for restaurants, hospitals, retail centres, schools, offices, banks, conference rooms - any location where people need to communicate, routinely or in an emergency!

## SMART CALL SYSTEMS

Expandable from simple message (calls) to high security RS485-line master and slave units!

Wired and wireless, used to upgrade existing two-wire systems or built over the top using wireless technology. Systems can be voice or alarms, data or control signals.

## SMART CALL SYSTEMS

**JACOBSON'S** ■ Thore Jacobsson ■ Nedralid S., 591 97 Motala, Sweden  
 Phone +46-141-220-331 ■ Fax +46-141-220-111 ■ GSM +46-706-010-331 ■ e-mail jacobson@swipnet.se



# Year #30\* Filters For Cable TV • TVRO • Interference

## New 100 Page Filter Catalog

Has a filter for every application

- CABLE TV SYSTEMS
- SATELLITE RECEPTION
- OFF AIR INTERFERENCE

### CONTENTS

GET  
IT  
TODAY!

#### CATV:

HISTORY

BANDPASS FILTERS

CHANNEL DELETION FILTERS:

Single channel deletion filters

Multiple channel deletion filters

LOWPASS FILTERS

HIGHPASS FILTERS

CHANNEL REPROCESSING NETWORKS

BANDSPLITTERS (hi/lo diplexers)

PAY TV TRAPS & FILTERS:

History of CATV trapping

INTERFERENCE SUPPRESSION

NETWORK PASSIVES

DROP LINE DEVICES

WEATHERIZED HOUSINGS

**TVRO:** FILTERS TO SUPPRESS INTERFERENCE

**BOOKS:** CATV, TVRO, MMDS, INTERFERENCE

APPENDIX A: INTERNATIONAL CHANNEL FORMATS

APPENDIX B: INTERNATIONAL CHANNEL FREQUENCIES

APPENDIX C: ORIGIN OF CATV, TVRO, PAY-TV

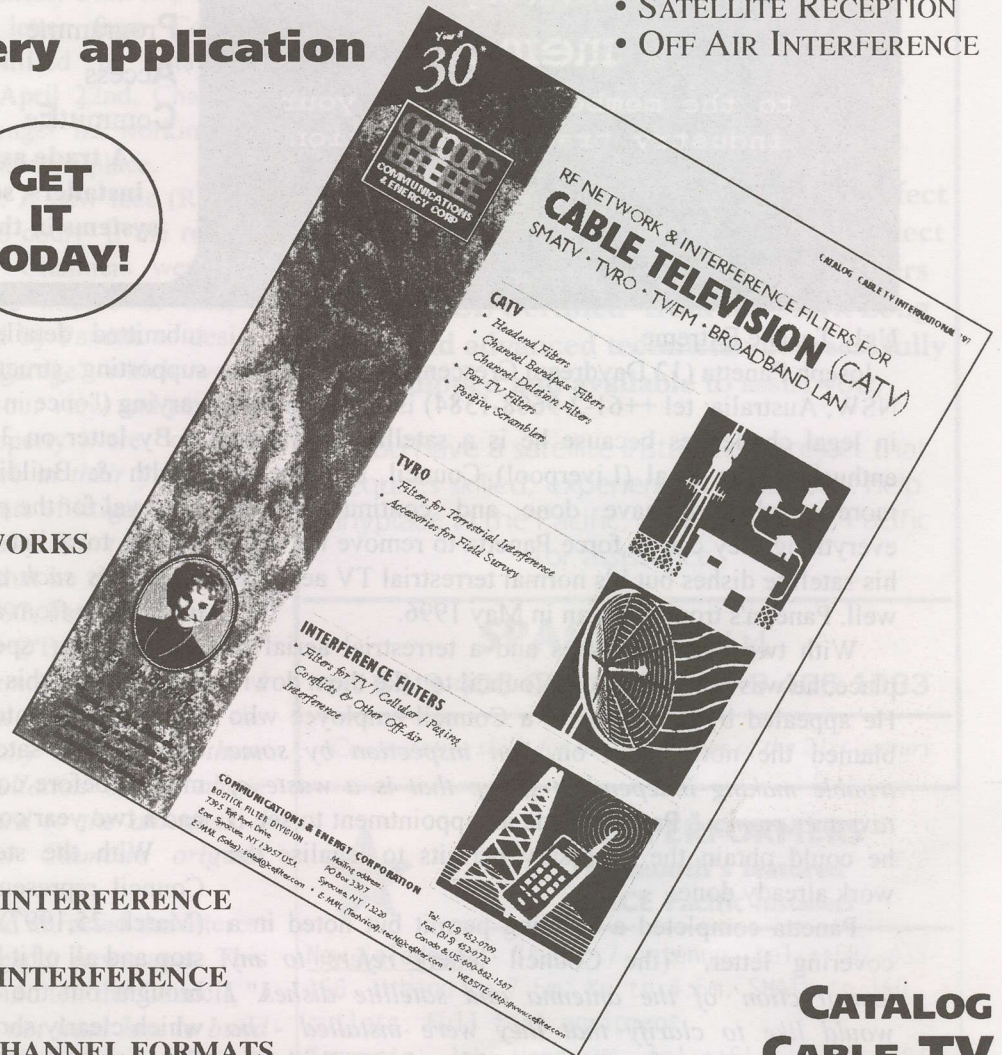

**CATALOG  
CABLE TV  
INTERNATIONAL/97**

More than a catalog of products-  
It's also a tutorial on CATV history and practices.



Emily Bostick  
President

*Emily Bostick*

**\*Emily & Glyn Bostick -  
Continuing a generation  
of personal service to  
TV industries -WORLDWIDE!**



7395 Taft Park Drive  
East Syracuse, NY 13057  
Mailing address:  
PO Box 3307  
Syracuse, NY 13220  
Tel: (315) 452-0709  
Fax: (315) 452-0732  
Canada & US: 800-882-1587

## DISTRIBUTOR INQUIRIES INVITED

Telephone: 315-452-0709

Fax: 315-452-0732 USA

Literature: Ileen Feinberg

Technical: Dave Dann, Tracy Warren, Steve Shafer, Glyn Bostick



a technical and marketing  
advisory  
**memo**  
to the membership from your  
industry trade association

## SPACE Pacific

Satellite  
Programme  
Access  
CommittEe



A trade association for users, designers,  
installers, sellers of private satellite-direct  
systems in the Pacific Ocean & Asia Regions

### Ugly To The Extreme

Joseph Panetta (12 Daydream Crescent, Hinchinbrook, NSW, Australia; tel ++61-2-9608-1384) is up to his ears in legal challenges because he is a satellite television enthusiast. His local (Liverpool) Council, and one or more neighbours have done and continue to do everything they can to force Panetta to remove not only his satellite dishes but his normal terrestrial TV aerial as well. Panetta's trouble began in May 1996.

With two satellite dishes and a terrestrial aerial in place, he was notified by the Council to take them down. He appealed by telephone to a Council employee who blamed the notification on, "*an inspection by some trouble making independent group that is a waste of taxpayer money.*" Panetta made an appointment to see if he could obtain the necessary permits to legalise the work already done.

Panetta completed a building permit but noted in a covering letter, "(the Council letter) *refers to my 'construction' of the antenna and satellite dishes. I would like to clarify that they were installed - no building work, as such, was undertaken.*" With the submission were letters of "no objection" from all (four) adjoining neighbours, engineering drawings and descriptive detail of the installations. And - payment of \$155 covering a building fee, an inspection fee and an archive fee, all acknowledged by Council.

It covered a 12 metre mast for reception from 8 Sydney TV transmitters, 5 from Wollongong and five satellite dishes (3.7m, 3.5m x 2, 2.4m and 1.2m). From all of this he would create a miniature CATV system with 21 channels and had a standing offer to connect neighbours "free of charge." Structural drawings

submitted detailed the weight of the antennas, the supporting structures, and the safety margins under varying ("once in 100 year") winds.

By letter on 3 January, 1997, Senior Environmental Health & Building Surveyor Gary Chalmers granted approval for the project ("Proposed Class 10a Antenna") subject to a list of standard conditions ("*Flashings in wet areas such as bathrooms*"); clearly the conditions listed were from a form relating to *any* new construction and nothing specific to the antenna system was included. At this point Panetta had one terrestrial mast, two satellite antennas in place with Council approval covering five satellite antennas. It would be nearly three months before construction could start but the approval had a two year completion date.

With the steel installed per the approved plans, Council representative Chalmers appeared on the site (March 25, 1997) insisting the "*illegal building work*" stop and all of it be taken down within 24 hours. Panetta brought out the approval and his original application, which clearly shows (SPACE has reviewed the full file) five separate antennas. Chalmers pointed to photos with the application and said, "*this is what I approved.*" indicating the two dishes previously existing.

It is now clear Chalmers had paid little if any attention to the detailed plans and his entire review of the matter apparently consisted of looking at the attached photos only. He would not admit his oversight and insisted on major changes in the work already done. Before he would leave the property, he urged Panetta to scrap plans for the 3.7m (replacing it with a 1.8), moving the 2.4m down to roof level, and relocating the 3.5m antennas to the ground. Panetta reluctantly agreed to the

## MEMBERSHIP IN SPACE

Membership in SPACE Pacific is open to any individual or firm involved in the "satellite-direct" world in the Pacific and Asia regions. There are four levels of membership covering "Individuals," the "Installer/Dealer," the "Cable/SMATV Operator," and the "Importer/Distributor/Programmer." All levels receive periodic programme and equipment access updates from SPACE, significant discounts on goods and services from many member firms, and major discounts while attending the annual SPRCS (industry technical conference) each year in New Zealand. Members also participate in policy creation forums, have correspondence training courses available. To find out more, contact (fax) 64-9-406-1083 or use information request card, page 38, this issue of SatFACTS. Page space within SatFACTS is donated each month to the trade association without cost by the publisher.



changes and immediately began taking structures down and rebuilding per Chalmer's negotiated plan. Chalmers was to return the next day with paperwork approving the changes, an appointment he never kept. Several more postponed appointments - no Chalmers. Until two weeks had passed and now a new letter from Council demanding everything (as modified to Chalmer's instruction) be taken down. On April 22nd, Chalmers advised Panetta he would no longer be working for Council and someone else would take his place.

And so it began all over again. A new face (Russell O'Brien), new threats of "going to court" if the revised structures verbally approved by Chalmers were not taken down, immediately. In the middle of this, a Chalmers instigated plan accepted by Panetta to design and construct a "purpose built garage" which would "shield" the antennas from neighbour view and partially conceal that on the Panetta property were "objects" which his neighbours did not have in *their* yards. The project was now out of hand; threats of litigation, a new bank loan to build a garage he really *didn't* want just to shield some antennas from view that he *did* want. In a letter to Council September 18, 1997, Panetta wrote:

*"After the most recent visit (by O'Brien) on 12.09.97 and being requested again to remove the antennas, I will state that this is my final attempt to fix the problems. Any disapproval or any changes to these (garage) plans will cause cancellation of the above building proposal and with regard to the antennas, I will reinstall everything as per Council's original approval dated 03.01.97."*

By mid November the matter had attracted the interest of a reporter for the Liverpool Leader newspaper. This in turn led to a neighbour who would tell the Council, "*I do not like Mr. Panetta and I do not want him to build anything more on his property.*" A neighbourhood lynch party was forming. Following a well attended meeting at Council on 20 November, it was agreed Panetta should drop his plans for the unnecessary garage and return to his original antenna installation, "*as approved by Council.*" As that was Panetta's objective all along, he readily agreed. The lynch mob was not giving up and Council on 9 December advised Panetta they had changed their minds again - *no garage, no antennas*. On advice of a solicitor, Panetta advised Council there would be no more *verbal* meetings without everything in writing in advance. Council's O'Brien balked at there being a written record and returned to his threats to take Panetta to court.

On 3 March 1998 the Council's solicitor notified Panetta all antennas were to come down or a (Land and Environment) court action would be filed. Panetta feels he is being deprived of his legal rights and subjected to abusive action by Council members and neighbours. If this were you, what would you do? SPACE suggests support for his position go directly to Joseph Panetta.

## NETWORK PLANNERS / OPERATORS

Looking for qualified system installers within the region from Tahiti to Western Australia? SPACE Pacific can help.

**SPACE Pacific Installer/Dealer and Retransmission level members are the perfect contractor source for one off, or large project C or Ku band installations. Many members are "SPACE Certified" from the Mark Long digital and advanced technician courses, fully equipped and available to assist you.**

If you have a satellite installation project that requires skilled, experienced contractor help anywhere in the Pacific, contact SPACE Pacific for assistance.

**SPACE Pacific Ltd.**

tel 64-9-406-0651 ■ fax 64-9-406-1083

*Co-operative skills for the challenges of the 21st century.*



### STAR PERFORMERS

**This month's featured  
SPACE Pacific Installers**

**New Caledonia** • Studio 7 Antenne, tel ++687-438-156. C-band to 7.5m, Ku to 4.5m. SMATV to 160 outlets. Full test equipment.

**Tasmania** • Jake Hendriks, tel ++61-03-6425-2104. DTH C-band to 3m, Ku to 2.3m.

**Napier-Hastings, NZ** • Town & Country Antenna Systems, tel ++64-6-878-6801. SMATV to 50 outlets. *SPACE Digital Certified.*

**Gunald, Queensland** • KANSAT, tel ++61-7-5484-6246. DTH C-band to 3.7m, Ku to 2.5m.

**Auckland, NZ** • ORAC Electronics, tel ++64-9-443-5111. DTH C-band to 3.7m, Ku to 1m. STARnet digital.

**Sydney, NSW** • C & H Electrical, tel ++61-2-9639-0713. C-band to 7m, Ku to 4m, SMATV to 100 outlets, full test equipment, qualified electrical supervisor.

### GARDINER 0.6 dB Ku LNBS?

Still require two 11.3 GHz LO, 12.25 - 12.75 Gardiner point 6 dB LNBS for our cable system; buy, or trade you out of them.

**Far North Cable TV Ltd** tel 64-9-406-0651,  
fax 64-9-406-1083



# The CABLE Connection

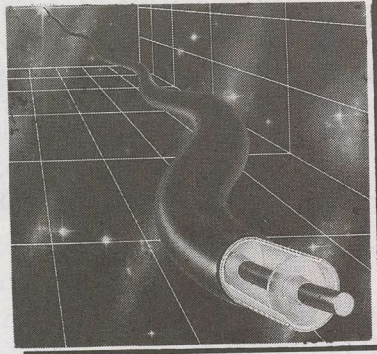

## Tight Connections

It was a normal Sunday in the cable plant; dry, clear weather, gentle winds, no subscriber telephone calls all day. Until 4.29PM.

Telephone log: 4.29PM: "There are lines all over the picture on every channel I have checked but the sound is OK. Can you fix it, fast? Rugby is on TV1."

Telephone log at 4.30PM: "What has happened to the picture on channel 3? Lines running through the picture, I can't watch anything!"

And nine more calls within 4 minutes, all reporting the same thing. Odd; all 11 calls were at the two extreme ends of the plant. With the headend near the middle, and trunk running west through 21 amplifiers to the end and east through 15 amplifiers to that end, a quick map plot showed all calls were at least 14 amplifiers out in both directions.

The plant shares one, single, common trunk amp after the headend and then splits to go east (14 more amps) and west (20 additional amps). First stop, the common trunk amp. The procedure is to check the input and then output levels through the 20 dB down test ports built into the amplifier. You normally only need to do this on two channels; one near the low end of the spectrum, one near the top end. As the plant runs AGC (automatic gain control) using two TV carriers (62.25 and 447.25 MHz), these have always been the "quick check" frequencies monitored at an amplifier location.

Remove the seven screws holding the amplifier weather housing in place, then the six captive bolts that seals up the trunk amplifier; elapsed time - about 3 minutes from sitting down on the ground at the amplifier

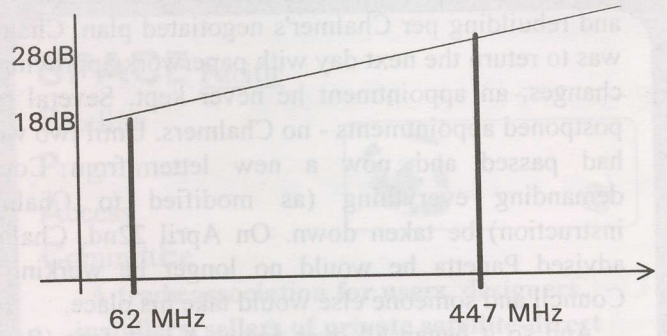

NORMAL AGC trunk amplifier operation

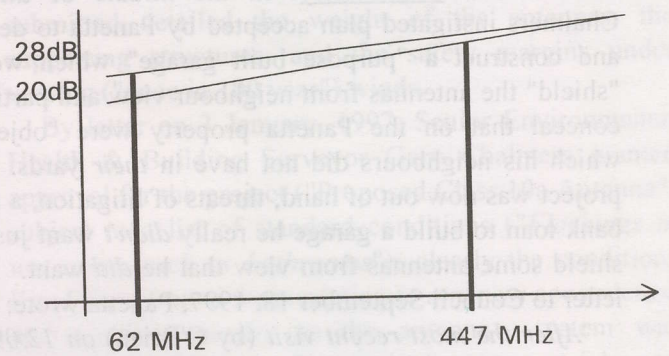

62 MHz goes "low" by 2 dB; amp raises output 2 dB to compensate for lower input

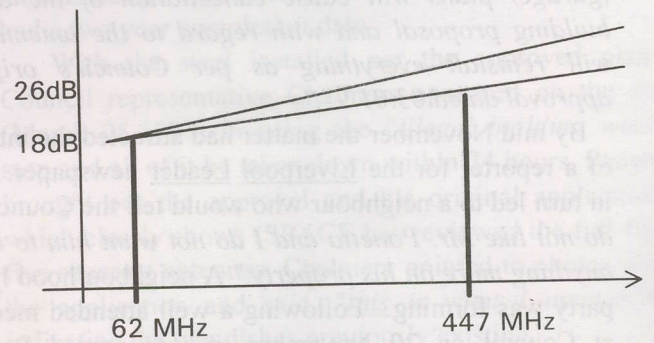

447 MHz goes "high" by 2 dB, amp lowers output 2 dB to compensate for higher input

location. Now plug the signal level meter into the input test port - 62.25 MHz is right on the button. Rapid

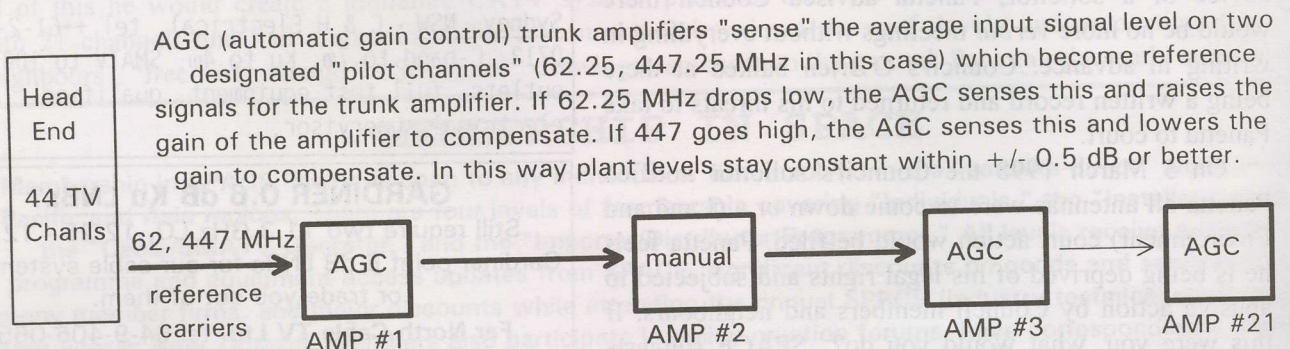

AGC (automatic gain control) trunk amplifiers "sense" the average input signal level on two designated "pilot channels" (62.25, 447.25 MHz in this case) which become reference signals for the trunk amplifier. If 62.25 MHz drops low, the AGC senses this and raises the gain of the amplifier to compensate. If 447 goes high, the AGC senses this and lowers the gain to compensate. In this way plant levels stay constant within +/- 0.5 dB or better.



### Condition "Red"

- #1) Either pilot / sense carrier modulator ceases to function
- #2) Within "reserve gain" capability, each AGC trunk amplifier in the string raises gain to maximum trying to compensate for "missing" pilot signal
- #3) With 21 amplifiers in cascade, and 11 of these running in AGC mode, and 4 dB of "reserve" gain at each AGC trunk amp - the potential arithmetic increase at the end of 21 trunk amps could be as much as 11 x 4 dB or 44 dB of signal level!

scanning upward in frequency to 447, everything looks normal through 439.25 MHz.

*But what is this?* There is nothing - no signal at all on 447.25 MHz! One missing TV channel out of 44 in the system - what's that have to do with the trouble calls?

Everything. Because the trunk amplifiers internally monitor the input levels on 62.25 and 447.25 MHz, if either of these "reference" carriers were to shut down, the automatic gain circuit in the amplifier would immediately respond by raising the gain in that portion of the passband (low end if 62.25 disappeared, high end if 447.25 quit) to the gain limit of the amplifier. With 447 "missing," every AGC function trunk amp down the line had tried to compensate by raising the amplifier output level from approximately 100 MHz to 550 MHz; as much as 4 dB at each amplifier at 550 MHz, a fraction of that at 100 MHz because of the gain tilt circuits built into each amplifier.

Down the line, after some number of AGC gain amplifiers each responding to the missing 447 reference signal, the amplifier network had raised gains so high that subsequent trunks were over driven by too much signal creating cross modulation and inter mod as well. In short, *lines in the pictures on all channels.*

With 447.25 "off," the cable plant had gone into a condition "red" overload. Why only after 14 or so trunk amps on each plant leg? Because the amps had been able to handle the overload for a distance but as the overload condition got worse and worse at each successive AGC controlled trunk amplifier, eventually the dam burst and crud appeared in the pictures.

Solution? Beat it back to the headend and find out what happened to the 447.25 MHz modulator! And if it could not be fixed, pronto, dial up one of the frequency hopping agile modulators to 447.25 quickly to get a reference signal back on the plant. Before the Rugby fans come after you!

The fix? Around 4.28PM, we had been in the headend chasing a problem with a Panasat IRD that processes RAI. It refused to unlock from a frozen image and we had pulled the AC line plug clearly marked "RAI" from the power strip to shut down and force a reset on the IRD. Only - *only* the power cord for RAI and the power cord for the 447.25 modulator were mis-marked and we had pulled the 447.25 by mistake! Quick fix - panic over.

Distribution centre of DVB MPEG-2 digital receivers for FREE-TO-AIR satellite TV programmes.

Wholesale & Retail Welcome

Consumer grade ---  
**HYUNDAI (HSS-100C),**  
**NOKIA (DVB 9500S),**  
**PACE (DSR 200)**

Professional grade ---  
**DMV (System 3000),**  
**Hirschmann (DVB7500)**  
**Philips (DVS 3950/11)**

Satellite IF distribution equipment --  
**GLOBAL.**

Come and visit us if you pass by Hong Kong!

Hong Kong Satellite TV Ltd., Unit C, 7/F, Block 6, Tien Chu Centre, 74 Pak Tai St, Tokwawan, Kowloon, HONG KONG  
tel: (852)2736-8703  
fax: (852)2735-0583  
email: hkstv@netvigator.com

YES, please send me info about \_\_\_\_\_ brand Company \_\_\_\_\_

Detail address: \_\_\_\_\_

\_\_\_\_\_ p/code \_\_\_\_\_

Tel: \_\_\_\_\_

Fax: \_\_\_\_\_

### Scientific Atlanta D9223 MPEG Receivers A\$1450

AV-COMM Pty Ltd has in stock "surplus to needs" high performance SA D9223 receivers fully compatible with the popular PowerVu (CA & FTA) bouquets found on PanAmSat satellites (software version 1.20/1.05 [2]). All units are pre-tested, rack mount IRDs suitable for satellite enthusiast or commercial applications.

Why pay more than twice as much for an identical receiver from SA direct? EMS shipping to New Zealand (and Pacific islands) available for A\$70, air parcel at A\$50 (NZ).

YES GARRY - Please send \_\_\_\_\_ D9223 MPEG receivers @ A\$1450 each + shipping.

Credit card # \_\_\_\_\_ - \_\_\_\_\_ - \_\_\_\_\_

exp \_\_\_ / \_\_\_ Signature \_\_\_\_\_

Name \_\_\_\_\_

Delivery address \_\_\_\_\_

p/code \_\_\_\_\_ Tel \_\_\_\_\_

**AV-COMM Pty Ltd** (ACN 002-174-478)  
198 Condamine St, Balgowlah NSW 2093, Australia  
Tel 61-2-9949-7417 Fax 61-2-9949-7095



# SatFACTS Pacific/Asian Region Orbit Watch: 15 May 1998

Copyright 1998: SatFACTS, PO Box 330, Mangonui, Far North, New Zealand (Fax: 64-9-406-1083)

Analogue Free-to-Air 57E to 80E	
DD1	55E/2DT 1330/L
Sun Music	57E/703 1395/R
RTNC	1352/R
Gemini	1220/R
AsiaNet	1170/R
WorldNet	1095/R
TVi	1025/R
Muslim	975/L
Tests	66E/704 1385/R
Mongolia	1135/L
Home TV	68.8/Pas4 Vt/1310
ABN	Hz/1365
BBC W	Vt/1286
Sony TV (Hindi)	Hz/1240
SAT-7	Hz/1218
Doordar.	Vt/1116
CNNI	Hz/1065
TNT/Cart.	Hz/1040
MTV Asia	Hz/965
ZJTV/ Plus 21	76/Ap2R 1390/Vt
TVT	78.5/Th3 1280/Vt
Army TV	1390/Vt
MRTV	1465/Vt
UTV tests	1500/Hz
RAJ-TV	1510/Vt
LLK/Sony	1630/Hz
TK Rossija	80/Exprs. 1475/L
Feeds	1315/L
VTV4+	1275/L
ACT/TB3	1225/L
TV Center	1025/L

Anal. Free-to-Air 80E to 113E	
Russia 3	80/Exprs 1025/R
RTR I	90/S6 1475/R
Orbita I	1275/R
RTR II	1234/R
Orbita II	1215/R
VTV4	91.5/Me1 Hz/1440
RTM1	1270/Hz
Metro	93.5/In2b 987/Hz
National	1022/Vt
DD9	1080/Hz
DD.7 (T)	1070/Vt
DD.9(K)	1180/Vt
DD.1	1268/Vt
DD.	1310/Vt
DD.4	1388/Vt
ORT 1	96.5/S14 1475/R
Madagas-car ++	1325/R
Tv Azer.	1275/R
ERTU Egypt	100.4/As2 1508/Hz
TV Shopping	1490/Vt
Feeds/Iran	1470/Hz
Star News (India)	1410/Vt
Feeds	1290/Vt
WorldNet	1265/Hz
CCTV4	1190/Hz
RTPi	1170/Vt
RTR	103/S21 1475/R
Vrk/Apt	1275/R
TPI	113/C2 967Vt
CPI/TV5	990/Hz

Anal. Free-to-Air 113E to 148E	
Brunei, feeds	113/C2 1010/Vt
MTV Asia	1030/Hz
Herbalife	1070/Hz
TV Indosiar	1090/Vt
CNBC	1110/Hz
ANteve	1130/Vt
CNNI	1177/Vt
SCTV	1190/Hz
GMA	1240/Hz
TV3	1250/Vt
ATV(7) Australia	1270/Hz
TVRI	1310/Hz
Gujarat +	1350/Hz
RCTI	1408/Vt
Moscow	122/As-G 1475/L
Test Card	128/Jc3 1070Vt
Test Card	1170/Hz
CETV SD	134/Ap1A 1330/Hz
CETV2	1250/Vt
CETV1	1170/Vt
CCTV7	138/Ap1 990/Hz
Orbita-I	140/S7 1475/R
ORT1	145/S16 1475/R
RTR Russia	1275/R
Test Card	148/Me2 1070/Hz

**Worldstar Radio Sat**  
 Asiastar 1 to 105E (12/98); downlink 1.451-1.492 (GHz). Audio channel capacity: 576 @ 16Kbit/s.

An. Free-to-Air 150E to 180E	
RCTI	150/C1 990/Hz
NHK	169/Pas2 1090/Vt
CNNI	1183/Hz
CNN Feeds	1155/Hz
Feeds	1370/Vt
TV Shopping	1400/Hz
Feeds	174/1802 984/R
Feeds	973/R
Feeds (KBS)	177/1702 984/R
Feeds	963/R
Feeds	180/1701 1340/R
RFO	1309/L
Feeds	1220/R
Feeds	1175/R
Feeds	1090/L
Feeds	1020/L

PALAPA C1 150.5E	
Tests	990Hz
Tests	1140Hz
Tests	1220Hz
Tests	1330Hz
Tests	1360Hz

C1 not recently reported

Encrypted Analogue	
Discov. India	68.8/Pas4 1365/Vt
ESPN	1290/Hz
HBO Asia (d) *	113/C2 1150/Hz

\* No longer available DTH. only to cable TV headends (Taiwan, Philippines); B-MAC.

## NON MPEG-2 DIGITAL SERVICES

People's Net (GI 1.5)	113/C2 1220/Hz
RPN-9 (SA 1.5)	142/G2 1225/L
Fox/Prime (SA 1.5)	169/Pas2/ 1161/Vt
Filipino Channel (GI 1.5)	1314/Hz

**May ALERT**  
 As Optus "DTH" comes closer and closer to a public announcement, continue to keep an eye on B3 Hz 12.564 and 12.626. When it goes CA (Irdeto) even as a test, commercial operation is near. Channelling "revision" May 7th was believed to be in anticipation of CA turn-on. Ku searchers should watch 148W for signs of new Echostar (LHC) services directed at NA. To follow Indonesian "unrest" see TVRI (3840/1310Hz) C2 and Star News (3740/ 1410Vt) As2.

Polarisation?  
 /L is left hand circular. /R is right hand circular. /Vt is linear vertical, /Hz is linear horizontal.



How to use These Tables  
5750/11.300

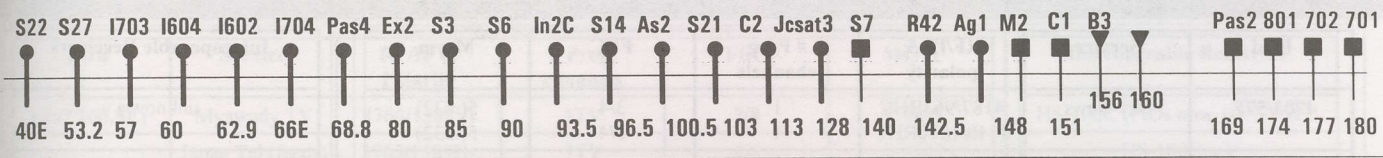

**OPTUS B3  
156E  
(Ku only)**

ABC WA	1358/Vt B-MAC
Imparja	1355/Vt B-MAC
GWN (to Sept.)	1300/Vt B-MAC
Net 9, Sky	1233/Vt B-Mac
Austar test (Temp OFF)	1389/Hz Mpeg2
Optus test Mpeg2	1326/Hz
Optus Mpeg test	1264/Hz
BMAC	1230/Hz
School tv	1170/Vt
Galaxy	1137/Hz Irdeto Mpeg 2
Galaxy	1073/Hz Irdeto Mpeg 2
Imparja	1040/Hz B-MAC

**Optus A3/152E(a)**

ATN7png	1297/Vt
ATN7png	1430/Vt

a/occasional use

**Palapa C2 Ku  
(seen South  
equator)/113E**

Test bars	11.148/Vt
-----------	-----------

**MeaSat 2  
148E**

Tests	1070/Hz*
-------	----------

\* Colour bars , audio 6.8;  
C-band covers Aust. NZ

**OPTUS B1  
160E  
(Ku only)**

Data	1402/Hz
QSTV	1377/Hz B-MAC
SE ABC HACBSS	1370/Vt B-MAC
SE SBS HACBSS	1344/Vt B-MAC
NE SBS HACBSS	1339/Hz B-MAC
NE ABC HACBSS	1313/Hz B-MAC
Sky Channel	1296/Vt B-MAC
ABC Radio	1276/Hz (digital)
OmniCast	1270/Vt (FM/FM)
ABC feeds	1247/Hz Pal
Sky Nz (sport)	1245/Vt VidCrypt
Net 9 feeds	1220/Hz B-MAC
Sky Nz (Orange)	1218/Vt VidCrypt
Net 10	1182/Vt E-Pal
Net 9	1180/Hz E-Pal
Net 10 feeds	1155/Vt Pal
QTQ9	1145/Vt
Optus test	1124/Vt
7 Net	1086.Vt E-PAL
Aurora MPEG-2	1076/Hz (tests)
CAA air to ground	1009/Vt Nbfm

**PAS-2  
169E  
(C + Ku)**

CCTV	1433.5/Vt (Sa9223)
Napa feed	1407/Hz
Value Ch.	1400/Vt
Discovery PowerVu	1374/Hz (Sa9223)
AB Asia, feeds	1335/Vt
ABS/CBN	1314/Hz (GI 1.5)
WCE-TV, feeds	1250/Vt
MPEG-2 PowerVu	1249/Hz (Sa9223)
CNN+ (1/2Tr)	1183/Hz
FoxSports	1160/Vt (SA 1.5)
Feeds	1150/Hz
NHK (digital)	1115/Hz
NHK anal.	1090/Vt
NBC Mux MPEG	1057Vt (Philips)
MPEG-2 PowerVu HonKong	1002/Vt
TCS Sing.	967/Hz

**PAS-2 Ku**

GWN	12.263V
MediNet	12.286V
Telstra Bendigo	12.300V
Napa TC	12.415V
MTV Asia	12.604V (MPEG)
ABC Interchge	12.629, 638, 646 /Vt
Herblife	12.732H

**Intelsat 801  
174E**

Feeds	963/R
Feeds	984/R

**Intelsat 702  
177E**

Feeds	963/R
AFRTS	973/L (PowVu)
Feeds/ KBS	984/R
Space TV Sys	12.612H (MPEG)

**Intelsat 513  
177W**

Feeds	963/R
Feeds	984/R

**(513 Ku)**

Service	RF Freq.
US Nets	10.980V
NBC	11.015V
Feeds	10.510V

**Ku Services**  
Intelsat Ku band services shown here are boresighted to Japan and nearby Asia, have not been reported south of equator.

**Intelsat 701  
180E(W)**

TVNZ	955/Dmv 3000
TVNZ	964/Dmv
TVNZ	972/Dmv
TVNZ	980/Dmv
TVNZ	988/Dmv
Occ Vid.	1,020**
TVNZ	1,030
RFO +	1055**
SPN	1,069
Feeds	1,090**
SCPC	1,126
SCPC	1,136
Vidip/(e)	1,220
Feeds	1,254
NHK(e), NBC	1,270
TVNZ	1,293/e
RFOanal	1,309**
Feeds	1,340
10 Oz MCPC (PwRvu)	1,385
CNN USA(e)	1430

\* RHC & LHC  
\*\* LHC only  
e/ encryption

**(701 Ku)**

NHK	11.135H
CBS	11.475H
CNN	11.508H

**UPCOMING SATELLITE LAUNCHES**

ChinaStar 1 to 87.5E (?) now May 19  
Sinosat 1 - "June"  
Intelsat 805 now scheduled June 18  
JcSAT6 delayed to July 30  
Orion to 139E; now October 1  
AsiaSat 3S March 1999 to 105.5E

Vertical handwritten notes on the right margin, including "3300 Hz" and "MPEG-2".



# SatFACTS Pacific/Asian MPEG-2 Digital Watch: 15 May 1998

Bird	Service	RF/IF & polarity	# Prog channels	FEC	Msym
I703/57E	Sky News	4187/963RHC	1	3/4	5(.632)
		4140/1010RHC	1	3/4	5(.632)
I704/66E	CFI	4055/1095RHC	4	3/4	27(.500)
	Indian bouquet	4068/1082LHC	2(?)	1/2	7(.100)
PAS4/68.5E	ART/ BBC	3980/1170Hz	2	3/4	5(.632)
	TVSN + TFC+	3743/1407Hz	6	3/4	21(.800)
	CCTV	3716/1434 Hz	6	3/4	19(.850)
Ap2/76E	AXN	3600/1550Hz	8	7/8	28(.340)
	Reuters	3636/1514Hz	1	3/4	5(.632)
	TVB 8	3689/1461Hz	2+	3/4	13(.240)
Thaicm 3/78.5E	UTV	3920/1230Hz	6TV(#1)	3/4	26(.662)
	UTV/MCOT	3880/1270Hz	8TV(#2)	3/4	27(.500)
	Reuters Feeds	3636/1514Hz	1TV	3/4	5(.632)
	Unknown	3600/1550Hz	8TV	3/4	26(.662)
Measat 1/91.5	India Bouquet	12284/12346Vt	10+TV?	7/8	30(.000)
As2/100.5E	Chinese tests	12.295Hz 12.329Hz	1TV 1TV (BTV 1)	2/3 1/2	6(.103) 6(.930)
As2/100.5E	Laos TV	4143/1007Hz	1TV	2/3	2(.889)
	Euro. Bouquet	4000/1150Hz	6TV, 1r. (#3)	3/4	28(.125)
	Hubei TV (HBTV Main)	3854/1296 Hz	2	3/4	4(.418)
	Hunan TV (SRTC)	3847/1303 Hz	1	3/4	4(.418)
	Guandong TV (GDTV)	3840/1310 Hz	1	3/4	4(.418)
	Inner Mongolia TV Zizhiqu	3828/1322 Hz	2	3/4	8(.397) (1-China) (2-Mongolia)
	APTV London	3800/1350 Hz	1	3/4	5(.631)
	BBC Radio	3793/1357 Hz	?	?	?
	WTN Jerusalem/ London	3790/1360 Hz	1	3/4	5(.631)
	WTN London	3786/1364Hz	1	3/4	5(.631)
	WTN HK	3775/1375 Hz	1	3/4	5(.631)
	Liaoning TV (Service 2)	3734/1416 Hz	1	3/4	4(.418)
	Jiangxi TV (JX Sat TV)	3727/1423 Hz	1	3/4	4(.418)
	Fujian TV (SETV)	3720/1430 Hz	1	3/4	4(.418)
	Qinghai TV Zenghou	3713/1437 Hz	1	3/4	4(.418)
	Henan TV Main	3706/1444 Hz	1	3/4	4(.418)
As2/100.5E	Sky Racing	4020/1135Vt	3TV	1/2	18(.000)
	EMTV	4006/1144Vt	1TV, 2 radio	3/4	5(.632)
	Hallmark/KIBC	3940/1210Vt	2TV, 4 aux.	2/3	26(.655)
	STAR TV	3900/1250Vt	7TV (#4)	7/8	26(.850)
	Hei Long Jiang	3834/1316Vt	1TV	3/4	4(.418)
	JSTV	3827/1323Vt	1TV	3/4	4(.418)
	AHTV	3820/1330Vt	1TV	3/4	4(.418)
	"QQQ" China (Shaanxi)	3813/1337 Vt	1, 1 Radio	3/4	4(.418)
	Guangxi GXTV	3806/1345Vt	1, 1 Radio	3/4	4(.418)
	Eastern TV Taiwan	3785/1365 Vt	5TV (#5)	3/4	18(.000)

Interoperable Receivers
unknown
N163/17X/2X. HS-100C
HS-100C, e3
e3
(MPEG-2, Iredeto) (CA)
Pv9223, N163/2X. HS-100C
Nokia e3, probably others
Any SCPC capable receiver
PowerVu (CA likely)
Mostly CA
Mostly CA
Nokia e3, probably others
Nokia e3, probably others
Philips
HS100C, e3
HS-100C, N163, e3
ANY DVB receiver
HS-100C, N163/17X/2X. N2000. Ph3950/11
HS-100C, N163/17X/2X. N2000. Ph3950/11
HS-100C, N163/17X/2X. N2000. Ph3950/11
HS-100C, N163/17X/2X. N2000. Ph3950/11
DMV, HS-100C, N163 /17X/2X
(Comstream ABR200/202)
DMV, HS-100C, N163/17X/ 2X
Mostly CA now
DMV, HS-100C, N163/173/2X
HS-100C, N163/17X/2X. N2000. Ph3950/11
HS-100C, N163/17X/2X. N2000. Ph3950/11
HS-100C, N163/17X/2X. N2000. Ph3950/11
HS-100C, N163/17X/2X. N2000. Ph3950/11
HS-100C, N163/17X/2X. N2000. Ph3950/11
Pace DVS-211 (CA)
HS-100C, N163, Pv9234
HS-100C (2.05), e3 (V5.0)
Now all CA (Pace DVS211)
HS-100C, e3
HS-100C, e3
HS-100C, e3
HS-100C, N163/17X/2X. N2000. Ph3950/11
HS-100C, N163/17X/2X. N2000.
Pv9223 (CA)

3770 H3  
 WTN Masqaw 5632, 3/4  
 AP2R - Pna 21 - 3787 H3  
 6.110, 3/4 - 6.110, 3/4  
 2/20/98 2/160  
 6/110, 3/4 - 6/110, 3/4



Bird	Service	RF/IF & Polarity	# Prog. channels	FEC	Msym	Interoperable Receivers
(As2/100.5E)	Myawady TV	3766/1384Vt	1TV	7/8	5(.080)	HS-100C (PIDs now 1062/1063)
	Japan Tel (feeds)	3765/1385Hz	1TV	3/4	5(.632)	HS-100C. e3
	STAR TV	3700/1450 Vt	8TV (#6)	3/4	28(.100)	Pace DVS-211 (CA).
C2/113E	Tests	11.500Hz	multiple TV	7/8	26(850)	Pace DVS-211 (CA)
	Star Indovision	3500/1650Hz 3580/1570Hz	20 TV (#7)	7/8	26(.850)	Pace DVS-211 (CA)
	Indovision	3460/1690Hz	6TV	7/8	21(000)	Pace DVS-211 (FTA?)
	MegaTV	3780/1370Vt	5TV (#8)	3/4	27(.500)	N2X/DVS-211(CA)
Thaicom 1/120E	Thailand terres.	4120/1030Vt	6TV	2/3	27(.500)	unknown
APIA/134E	AXN	4060/1090Vt	8	7/8	28(.340)	unknown
API/138E	Reuters	3732/1418Vt	1TV, data	3/4	5(.632)	N163/17X/2X
	CNNI + Cartoon	3980/1170Vt	2+ TV	3/4	26(000)	(CNN clear) / unknown
Palapa C1/150.5	Indovision	4117/1033Hz	10TV	7/8	26(.850)	same as 3580 C2
Optus B3 156E	Galaxy	12.438Hz 12.376Hz	20+TV (#9)	3/4	29(.473)	Gng. P400, P500, Pn520. + Pn630. Sk888 (e)
	(Inactive?)	Aurora Test	3+ TV	2/3	30(.000)	e3. HS100C
	Optus Vision	12.564 Hz 12.626 Hz	16TV (#9A)	3/4	29(.473) 29(.445)	(when testing is over. only IRDs with Irdeto CAM. card)
	Austar/Galaxy	12.689Hz	tests-up to 10TV	3/4	29(.473)	e3, HS100C, P400, P500, PN630
Optus B1 160E	Aurora (MPEG test)	12.377Hz	5+ TV (#10)	2/3	30(.000) [27(.500)]	N163/17X/2X. Pv9223. HS-100C
	PAS-2 169E	ABC Interchange	1 TV (each)	3/4	6(.980)	Pv9223, Hs100C. e3
	Telstra Bendigo	12.300Vt	3TV, 2 radio	1/2	10(.138)	Pv9223/9234. (CA)
(Inactive?)	Mediasat	12.286Vt	1TV	3/4	6(.610)	Pv9223, HS100C. e3 (some CA)
	GWN Perth	12.265Vt	2TV, radio	1/2	16(.200)	Pv9223/9234, HS100C. e3 (CA)
	MTV Asia	12.605Hz	8TV	1/2	22(.490)	Unknown- Asia beam only
	Hong Kong PowerVu	4148/1002 Vt	8TV (#12)	2/3	24(.430)	Pv9223, HS-100C(*), N2X* (some FTA)
	NBC Hong Kong	4093/1057 Vt	7TV (#13)	3/4	29(.473)	HS-100C, Gng, N163/17X/2X. P400 (b), P500, Pn520, Pn630. Sk888
	JET Singapore	3962/1188 Vt	2TV (1-Ntsc, 2-Pal)	1/2	13(.740)	Pv9223 (CA)
	ESPN (USA)	3860/1290Vt	4TV, 2 control	7/8	26(.470)	Pv9223 (CA)
	CCTV China PwrVu	3716.5/ 1433.5 Vt	5TV (#14)	3/4	19(.850)	Pv9223, HS-100C, N163/17X/2X (FTA)
	TCS Singapore	4183/967 Hz	2TV (#15)	1/2	6(.620)	Pv9223, HS-100C N17X/2X (FTA)
	ITJ- J. Telecom	4.174/976 Hz	1 TV	3/4	5(.632)	HS-100C
4151	AAR-ART/RAI Int	4153/997 Hz	3TV (#16)	3/4	5(.632)	HS-100C, Pv9223, N17X/2X, (continues FTA)
	Feeds	4138/1012Hz	1TV	3/4	6(.620)	HS-100C. e3
	NHK Joho	4035/1115Hz	5TV (#16A)	3/4	26(.470)	1CA/D9234; 2-FTA HS-100C +
	PAS-2 feeds	3940/1210 Hz	2TV(NTSC)	2/3	6(.620)	Pv9223, N2X, HS-100C
	California PowerVu	3901/1249Hz	8TV (#17)	3/4	30(.800)	Pv9223, HS-100C (*) N17X/2X (*). (some FTA)
	Disney/Aust.	3804/1346Hz	1TV	5/6	21(.093)	Pv9223 (CA)
	Discovery Singapore	3776/1374 Hz	7TV (#18)	3/4	21(.093)	Pv9223, HS100C, N2X (occasionally Ch. 2 FTA)
	Satcom 1-6	3743/1407Hz	6TV	7/8	19(.465)	Pv9223(CA)
	Unknown test	3718/1432 Hz	3TV	2/3	6(.620)	e3
1702/177E	AFRTS	4177/973 LHC	8TV, 12 radio & data (#19)	3/4	28(.000)	Pv9223 (CA)
	SPACE TV Systems	12.612/1312 Hz	13TV, 11 radio (#20)	3/4	26(.694)	XTCCDTV200 (All but 1 [#301] now CA)



# SatFACTS MPEG-2 Digital Watch: 15 May 1998 ♦ Support Data

Bird	Service	RF/IF & polar.	# Prog. Chs	FEC	Msym
1701/180E	TVNZ Gennet (feeds)	4195/955RHC	1TV(CA)	3/4	5.(632)
		4186/964	(BBC Gennet)		
		4178/972	1TV(CA)		
		4170/980	(APT/TKYO+)		
	Americas(radio)	4175/975LHC	3+ radio (?)	2/3	3.(680)
	TVNZ CRY	4120/1030RHC	1TV	3/4	5.(632)
	RFO-Canal +	4095/1055LHC	5TV (#21)	3/4	27.(500)
	SPN Nauru	4081/1069RHC	1TV	3/4	4.(730)
	SPACE TV	3922/1228LHC	2TV (FTA)	7/8	21.(200)
	TVNZTL	3857/1293RHC	MTV Europe	3/4	5.(632)
	10 Australia	3765/1385RHC	6TV	7/8	29.(900)

Interoperable Receivers
DMV.. HS100C, N17X, 2X, e3 (for non CA channels when active: not all channels active all of the time).
e3. (CA)
(see TVNZ above)
MPEG-2, 2-CA, 3 FTA
HS-100C, e3
Unknown - reception not verified
HS100C, e3 (now CA)
Hs100C, e3, Pv9223 (4ch CA)

**Bouquets:** 1) Thailand UTV: (1) CNN, (2) TTV, (3) ESPN, (4) HBO, (5) Ch. 5, (6) itv; 2) Thailand UTV/MCOT: (1)MCOT, (2) UTV Sports (3) test, (4) TTV News, (5) test, (6) Live, (7) Channel B, (8) Discovery; 3) European Bouquet. (1) Deutsche Welle, (2) MCM, (3) RAI International, (4) RTVE, (5) TV5 Paris; Radio (1) DW#1 (stereo), (2) DW#2 & 3, (3) DW#4 & 5, (4) YLE (left) & RCI (right), (5) WRN & test, (6) REE, (7) RF#1, (8) RF#2, (9) RFI Music, (10) RNW, (11) RAI, (12) NN, (13) SRI; 4) STAR TV Hong Kong. (Now all CA); 5) Eastern TV Taiwan. (1) "U1" [movies], (2) "U2" [news], (3) "U3" [sport, cartoons, general entertainment], (4) "Rock TV", (5) Rock TV; 6) STAR TV Hong Kong. (1) Channel 6, (2) ESPN Contributory, (3) Racing Ch., (4) Star Movies SEA, (5) Star Chinese, (6) NBC, (7) CNBC, (8) Sky News, (9) VIVA Cinema; 7) Indovision. (1) HBO Asia, (2) STAR Movies SEA, (3) Film Indonesia, (5) ESPN Asia, (6) STAR Sport, (8) Channel 'V' International, (9) Channel 'V' Asia, (10) RCTI, (11) STAR +, (12) Discovery, (13) STAR Movies and NBC Asia, (14) Phoenix Chinese, (15) CNN, (16) BBC World, (17) CNBC, (18) Cartoon + TNT, (19) Preview 1, (20) Preview 2; 8) MegaTV (1) CNNI, (2) Discovery, (3) ESPN Asia, (4) HBO Asia, (5) Cartoon + TNT, (7) Cinemax (7 may not be operating); 9) Galaxy. Presently 22 programme channels. 9A) Optus Vision tests, FTA as of 11-05-98 (temporarily): (1) Disney (2) MTV, (3) Odyssey, (4) AFL, (5) TNT, (6) Movie 1, (7) Movie Extra, (8) Movie Greats (9) Sport Australia, (10) ESPN, (11) Cartoon, (12) Sky News, (13) CNN, (14) Ovation, (15) World Movies, (16) CNBC; 10) Aurora. (1) SBS NT, (2)SBS NE, (3)SBS, (4) Sky News, (5) ABC WA ;12) Hong Kong PowerVu. (1) CTN 1, (2) CTN II, (3) TVBI Hong Kong, other feeds [NTSC], (4) TNT/Caroons [PAL], (5) Ad-hoc II [NTSC], (6) CNBC, (7) CTN II, (8) CTN; 13) NBC Hong Kong. (1) CNBC, (2) CNBC Mandarin A, (3) NBC Asia, (4) colour bars, occasional feeds, (5) CNBC Mandarin B (6) NBC "2" Asia/Taiwan, (7) Colour bars, "future" use; 14) CCTV China. (1) CCTV4, (2) CCTV3 [ (3) CCTV 9, (4) CCTV4, (5) CCTV5, (6) CCTV8, (7) CCTV tests; 15) TCS Singapore. (1) TCS Test, (2) TCS Default [repeats channel 1]; 16) SCPC3. (1) ad-hoc use, (2) AAR/ART, (3) RAI International; 16A) NHK World (1) NTSC Jap, (2) NTSC Eng, (3) PAL Jap, (4) PAL Eng, (5) NHK radio, (6) NHK Premium 17) California PowerVu. (1) CMT(NTSC), (2) CBS feeds, others including CTV Canada (NTSC), (3) ATN Asia TV Network (NTSC), (4) EWTN (NTSC) global Catholic radio, ch. 2, (5) BBC World (NTSC), (6) Bloomberg Financial (NTSC), (7) Golf Channel (NTSC), (8) Discovery Agm; 18) Discovery. (1) Disc. Aust/NZ, (2) Disc. default, (3) Disc. Japan, (4) Disc. SE Asia, (5) Disc. Taiwan, (6) Disc. Philippines, (7) Disc. China; 19) AFRTS. Up to 19 video, audio, data channels; non accessible (PowerVu CA); this is a very dangerous (Bootloader) place for D9223 receivers to be! 20) SPACE Systems (177E, Ku) claims to be back on the air with 11 CA Taiwan TV programming sources, 11 radio channels plus North American sourced adult channels Erotica and Exxtasy (all CA), and, (FTA) Thai TV 5 International (loads as Ch 301); 21) RFO (feeds from France). (1) Canal + Poly, (2) Canal + NC, (3) RFO1, (4) RFO2, (5) Saudi TV. (Note: BF (NTSC Jap) indicates FTA. SCPC (mostly FTA), some MCPC bouquets not listed here.

## MPEG-2 DVB RECEIVERS: [Data here is believed accurate; we assume no responsibility for errors in this volatile area!]

**AV-COMM R3100.** FTA, excellent sensitivity (reviewed SF May 15, 1998). Av-Comm Pty Ltd, tel ++61-2-9949-7417.  
**Benjamin DB-5000.** FTA, unknown operational characteristics. Telsat (64-6-356-2749); factory at fax ++886-2218-6484  
**DMV/NTL 3000.** Commercial receiver available in several software formats. Skandia Electronics Pty Ltd (tel 61-3-9819-2466)  
**Grundig (Gng) DTR1100** (badged Panasat 630, believed no longer in production). Av-Comm Pty Ltd (tel 61-2-9949-7417)  
**Hyundai-TV/Com.** Ceased production of HSS-100 family of IRDs in March. Still in pipeline, model HSS-100B/G (for Pacific) and HSS-100C (for China). Versions in 2.25/2.26 region were good performers, version 5.0 had tuner sensitivity and other problems. Skandia (tel 61-3-9819-2466) has version 3.11 about which nothing is known; SATECH (tel 61-3-9553-3399) has version 2.26.  
**MediaStar D7.** Supplier preloaded software known channels, V. 2.050 from Opac Pty Ltd. (61-2-9584-1233), Telsat (64-6-356-2749)  
**Nokia "d-box" (V1.7X)** suitable for C-band use. Instructions, on-screen prompts may be in German. Be careful when buying this one!  
**Nokia 9200/9500/9600.** There are too many Nokia versions to count. The original 9500S software version 1.63 was uniquely capable of going through a satellite and locating digital transponders and placing on the menu screen the Msym, FEC and operating frequency of every digital signal found whether FTA, CA, MCPC or SCPC. Sadly, that ability is gone with newer models. Current version software within 9200/9500/9600 model numbers is 5.0 or higher. Nokia refuses to support distributors in Asia or the Pacific and users are forced to locate and purchase product through European sources. The most helpful and knowledgeable Pacific region supplier for this product is AV-COMM Pty Ltd at tel 61-2-9949-7417. (See this listing, SatFACTS April 1998 and earlier for greater detail.)  
**PACE DVS-211.** Officially available only through Sky (racing) Australia (Bob Pankhurst tel 61-2-9451-0888).  
**PACE DGT400.** Through Galaxy offices, Australia (will not work on FTA if receiver has been over-air software upgraded [parental]).  
**PACE DVR-500.** Apparently no longer current except through NBC to cable, broadcast affiliates; basically DGT400, has CAM ability.  
**Panasat 520 (Pn520), 630 (Pn630), 635 no longer available;** spares through UEC in South Africa (fax ++27-31-593-370)  
**Panasonic TU-DC10/TU-DS10.** Scheduled for use in Optus RABS digital conversion; Antares Electronics tel ++61-7-3205-7574  
**UEC 642.** The (642) is scheduled through Nationwide Antennas (61-7-3252-2947) for Aurora project; first shipment arrived May 7th.  
**PowerVu D9223, 9225, 9234.** Scientific-Atlanta (Sydney) Tel 61-2-9452-3388; BaySat (tel 64-6-843-5296), Telsat (64-6-356-2749)  
 Note: SA D9223 receivers are RISKY to use for enthusiast purposes because of susceptibility to software overwrite during "boot-loading" sequence. Model 9234 is currently distributed in Western Australia for GWN reception under "RTIF" subsidy programme, and for NHK Premium through SA as well as in PNG for EMTV "authorised" sites.  
**SK888.** From Sun Moon Star through Skandia Electronics Pty Ltd. (tel 61-3-9819-2466)  
**XTC CDTV200.** (For Space TV Systems); only source James Tzeng at (USA/tel) ++1-714-529-9988 or fax ++1-714-529-9989  
**YURI HSS-100C.** Rebadged Hyundai, software 2.27 which is Australian created mod from V2.26. Nationwide (61-7-3252-2947)

Hyundai TVC 3200. has some...  
 KASTEL ELEMENTS, T 61-7-4788-8902, Fax 61-7-4788-8906.



# WITH THE OBSERVERS

"Intermittent programmers" (those only transmitting for a few hours, days or weeks) continue to come and go on the full range of Pacific and Asian satellites. Satellites owned by or intended to serve the region from Indonesia through Malaysia and Thailand continue to be the least predictable in operation, due in large to the fiscal (monetary) problems experienced by many Southeast Asian countries. Two, even one year ago, it was far easier to raise sufficient capital (money) to trial a new programming concept using short term rental satellite time. Programming that struck a responsive cord stayed, often moving to more permanent satellite space; that failing to make the grade simply disappeared. With money "tight" and attitudes changed about speculative ventures, far fewer short term "trial" programmers are appearing and of those that do, their trial periods tend to be so short that they are there and gone before most of us are even aware of their presence. Thaicom 3 and ApStar 2R "tests" are proving to be the most short-term of all; here today, gone tomorrow. For latest listings as we go to press, see Orbit Watch analogue pages.

**Zahid Hussein** (Fiji) and **Laurie Mathews** (Auckland) report the Country Music Television (CMT) FTA analogue tests late in April on PAS-2 (3900/1250Vt). Why this service went analogue and FTA for several days is not known; the normal PowerVu service continued through the same period.

Imparja's official announcement of selecting Optus for RABS digital service transmission (dated April 17) advises "new digital, decoder boxes will retail for around (A)\$1,000 - the federal government will provide \$750 towards the cost of a replacement (digital) decoder. Operators of licensed re-transmission sites will receive a subsidy of \$2,500 for purchase of replacement commercial grade decoders." Imparja warned viewers, "Over the next 4 to 5 weeks you will be provided with a further update, as well as details of an information hotline for your use. In the meantime, we ask that you don't try to contact us direct for more information."

**David Davids** (Gold Coast, Qld) reports the RFO 1 and 2 digital feeds detailed in SatFACTS April (4095/1055 LHC) requires a 3m dish as a minimum at his location and he finds it works only on the HSS-100C (older) 2.2 version software.

**Robin Colquhoun** (Auckland) reports a 3.7m antenna for this service at his location, and suggests the MPEG data stream may not be totally "DVB Compliant" resulting in some receivers have problems with decoding.

## AT PRESS DEADLINE

Indovision's May TV Guide announces "Welcome to the Digital Age" and explains S-band operations from Cakrawarta (107E) are now starting. CTD for April 29th reported C-band Indovision is scheduled to stop July 31. Anyone out there equipped to probe for the Cakrawarta S-band (2.52 - 2.67 GHz) signals?



Moscow NTV/HTB/TW6 service on 122E is making many Russian émigrés happy these days. Bird is inclined +/- 1.8 degrees, but 3675 LHC signal is very strong (old RAJ transponder) and of good video quality. (Seems strange to see US products advertised on Russian TV [below]!)



To our April question, "Do you notice Palapa C2 vertical signals stronger at night?", **David Leach** (NSW) says that is how he sees them. **Gareth Welsby** at Channel 8 Pty Ltd. (Boroko, PNG) believes his PAS-2 levels are also "better at

**WITH THE OBSERVERS:** Reports of new programmers, changes in established programming sources are encouraged from readers throughout the Pacific and Asian regions. Information shared here is an important tool in our ever expanding satellite TV universe. Photos of yourself, your equipment or off-air photos taken from your TV screen are welcomed. TV screen photos: If PAL or SECAM, set camera to f3.5-f5 at 1/15th second with ASA 100 film; for NTSC, change shutter speed to 1/30th. Use no flash, set camera on tripod or hold steady. Alternately submit any VHS speed, format reception directly to SatFACTS and we will photograph for you. Deadline for June 15th issue: June 5 by mail (use form appearing page 38), or 5PM NZT June 6th if by fax to 64-9-406-1083.



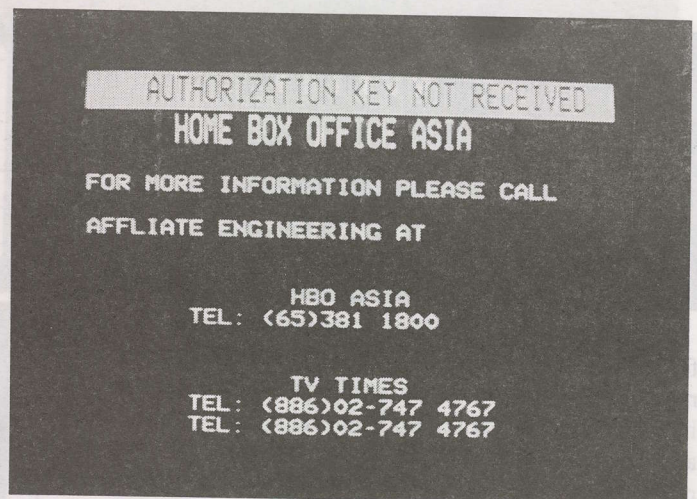

HERE FOR NOW (left) NHK World TV is viewable but at levels reduced from prior analogue service on temporary vertical side of PAS-2 (4060/1090); HBO on C2 is operating, but locked out except for cable TV affiliates as display (right) shows (home DTH service shut off April 15).

night." Other reports of day versus night differences? David Leach also reports his belief that Gorizont at 96.5E may have moved east towards AsiaSat 2 (100.5E), as we questioned in April. Other reports?

Steven McKelvie (Napier, NZ) reports NHK Digital runs between 10 and 11 dB SNR on his Hyundai receiver. Certainly this digital bouquet is the most impressive digital signal level currently coming out of PAS-2.

TV5 replacing CFI on Palapa C2? The original date was March 4th, as we reported. It did not happen. A substitute date was May 1, which also did not happen. TV5 assures us there is no change in the plan, merely slow implementation.

Express at 80E. Russian officials confirm this satellite's 3675 (TR6) transponder has died and they are flying a second satellite (Stationar 13) at this location for its 3675 ability. Transponders on board Express 6 still working are all beamed north-only while second-bird TR6 can be either global or north only (it operates north-only the majority of the time).

Observers who "miss" the now encrypted analogue ABC/CBS/Fox/NBC network feeds on I180 should check Intelsat 174E (4190R and 4170R) analogue. Scheduling is erratic.

Aurora digital testing on 12.407V (B3) has ceased but may come back, perhaps on a horizontal B3 transponder. Further



## Comet Installations is pleased to announce the acquisition of ACESAT



which has now been relocated to our modern warehouse premises at 321 Parramatta Road Auburn, Sydney NSW 2144

**Contact:**

**Tenders, Design & Installations - Allan Miller (Operations Manager)**  
Phone: (02) 9704 2975 Fax: (02) 9704 2977

**Product Sales - Doug Sawtell**  
Phone: (02) 9704 2976 Fax: (02) 9704 2977

**Comet Installations is Australia's largest Satellite & Cable Specialist with extensive experience in VSAT, TVRO, SMATV, MATV, Multi-media Interface, Head Ends, DTH and Cable.**

COMET INSTALLATIONS PTY LTD ACN 071 673 562



### OPEN LETTER - from a satisfied user of PAS-2

"Following our telephone conversation regarding the sudden problem I had receiving RAI International through PAS-2, and the lack of success which I experienced calling various numbers in Italy, I contacted PanAmSat in Sydney.

"I explained the problem and was given telephone details for their Napa (California) site, which I contacted to discuss my reception difficulties. They were unable to shed any light on the problem, so I re-contacted Sydney. John Cotterall (in Sydney) took ownership of the problem and rang me back a short time later to update. He said, 'yes - indeed - the transmission from PAS-2 was outside specification and would be adjusted'. I was later contacted by PanAmSat in the States to confirm that some adjustments had been made at the uplink site to reduce the noise component of the signal. Upon rechecking, I found the RAI signal was indeed much improved, but still not good enough to allow the IRD to lock for more than a few seconds. I recontacted the states and gave an update. The outcome was further investigation resulting in an increase in uplink power and a major improvement in the received signal.

"I am a great believer in giving praise where praise is due, and would like to take this opportunity to thank John Cotterall and his colleagues at PanAmSat in Sydney for assisting so readily in resolving the problem."

Peter Swain, Advanced Satellite and Cable Ltd, PO Box 3439, Wellington, NZ

Editor: Calling to complain is not always futile, even on a volatile service such as RAI/ART. See page 4 in this issue for an update on the RAI "situation" as of mid-May.

testing will largely depend upon the availability of IRDs for this service (see p. 36).

Several observers reporting PAS-2 Ku strong signals in region of 12.575 GHz; these appear to be data services for Australia and possibly NZ.

"Plus 21" adult service on Ap2R (3787Hz, Msym 6.110, FEC 3/4) is announcing on screen formal start June 1st. Queries to fax ++91-172-553-014.

Herbalife on C2, 4080/1070Hz, Monday/Wednesday 0100UTC.

RFO Tahiti occasional feeds I174E, 4166/984R.

## MICROWAVE EQUIPMENT

Transmit and receive over path lengths from 2 to 120 km, video or data. Equipment proven in New Zealand, in use for full-time links by 4 cable/data operators.

### ALSO AVAILABLE

4.6m Andrew C/Ku antenna (uplink capable)

5m SA C/Ku antenna (uplink capable)

Pacific Satellite Communications Ltd, Christchurch, NZ  
Tel 64-3-3662-661 • Fax 64-3-3662-660

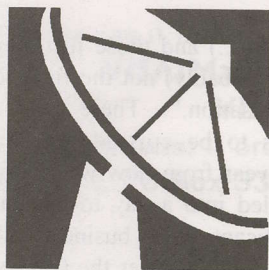

# MELBOURNE SATELLITES P/L

ACN 065 270 733  
Established 1992

Direct importers and suppliers of the following world renown products.

KTi  
ORBITRON  
PATRIOT  
JONSA  
ANDREW

ECHOSTAR  
SCIENTIFIC ATLANTA  
NOKIA  
IKUSI  
DX

GARDINER  
CALIFORNIA AMPLIFIER  
MTI  
CHAPARRAL  
ADL

Full range of cables, splitters and connectors.

Phone, fax or write for our 1998 Product SATalogue.

Sales/Warehouse - 84 Bayfield Road, Bayswater Victoria  
Construction Services - 13 Elsum Avenue, Bayswater Victoria  
Postal Address - PO Box 901, Bayswater 3153 Victoria Australia

Phone: (03) 9738 0888  
Fax: (03) 9729 8276



# AT

## Sign-off

### Aurora at the Brink

SatFACTS for April, this page, reported Francois Stols, Managing Director for South African manufacturer UEC, telling us (early in April):

*"I can say the expectation is that the first 642 IRDs will be intended for the Australian Aurora RABS market and we anticipate deliveries to commence in June."*

A draft press release prepared for management approval internal to Optus early in May lists three separate IRD suppliers for Aurora; a Panasonic (Comstream) TU-DC10/TS-DC10, the UEC 642 and a model (not yet named) from Sun Moon Star. You may remember Sun Moon Star as the people who created the Skandia SK888. SatFACTS for March 15th reported an Optus "masterplan" to have "2, 3 or even 4" IRDs available in the marketplace to give consumers a choice of hardware. We warned at the time the RABS marketplace was very small (some estimate 15,000; it now appears to be closer to 10,000), and we expressed concern that if there are too many IRD choices, vendor support (service) was likely to suffer because of price cutting.

On May 9th, an agreement was announced by the ABA guaranteeing continued WA access to B-MAC GWN through September. GWN had hoped to force viewers to adopt the dastardly SA D9234 format on PAS-2. Optus may be prepared to "write off" GWN allowing SA and PanAmSat a toehold (perhaps 2,000 IRDs) in Australia. Pity the fools who have bought 9234s and will soon find out they cannot participate in the great nation-wide DTH experience unless they invest in yet another (Irdeto equipped) IRD. There are believed to be 1,500 unused RABS/RTIF "vouchers" yet to be turned in for payment in WA, suggesting a number of people have not been hoodwinked by the SA + GWN ploy.

Rationalisation of the Australian pay-TV world is underway, starting with the operation of Australis / Galaxy passing into the hands of financial managers (receivers); see p. 1 here. Around May 15th, Optus will begin "testing" 16 DTH programme channels using 40 UEC 642 IRDs shipped in from South Africa for that purpose. With Galaxy in receivership, these 16 channels could be a life saver for Austar. Optus has chosen the same Irdeto conditional access mechanics as Galaxy and Austar, and in theory any existing DGT400 IRD set-up on transponders 10 and 11 could be reset for 13 and 14 and by plugging in a new Optus DTH Irdeto card, gain access to Optus DTH after Optus Vision elects to push the DTH "CA" button.

Optus Vision has been toying with a marketing plan to distribute their DTH service through retail outlets such as RetroVision and Beta. The concept is as follows:

1) Consumers already on Galaxy would go to an authorised Optus DTH "dealer" and put down \$50 as a security deposit for a new CA card.

2) Non Galaxy subscribers could also purchase a new IRD and "system" at the same retail outlet and decide whether they wished to install it themselves, or, arrange for the installation by an independent contractor.

3) With a working IRD system and conditional access card, the subscriber would then select programme channels from Optus for subscription. Various packages are under consideration, starting at \$19.95 per month and working upwards to over \$50.

There are two parallel DTH projects underway at Optus. RABS, which is strictly intended to replace the existing regional ABC + SBS + Qld/NT/WA analogue B-MAC services with digital, and, Optus DTH. RABS has tested and presently plans to be on vertical polarisation B3 in a national beam. Optus DTH will be on B3 horizontal. There is a minor case of bad planning here; with more forethought, the two could have been on the same polarity eliminating the need for polarity switching or dual LNBs at the DTH receiving sites. Perhaps Optus - the satellite company - will now find room on a horizontal high performance beam for RABS-digital to eliminate this technical hiccup.

*In theory*, the same UEC or Panasonic or Sun Moon Star IRD delivered for RABS could and will work for Optus DTH. The CA system is the same (Irdeto), and Optus could easily offer a card that does RABS only, another that does only Optus DTH and a third that does both. Placing IRDs and cards into the hands of retail outlets has proven to be the correct way to market satellite pay-TV in North America, Europe, the Middle East and Japan. The Galaxy 600 million dollar blunder is strong evidence the pay TV programmer has no business trying to manage the hardware segment as well; a lesson "tiny New Zealand" is about to learn as Sky NZ seems hell bent on repeating the mistakes of Galaxy.

Between the first set of dots (...) and those just above we have a scenario, but possibly (probably) not the final form of Australian pay-TV "rationalisation." There are many unanswered questions, hurdles to be crossed, regulators to pacify. Between today and a year from now when hopefully all but the dust will have settled into a day to day business pattern, there will be significant new business alliances formed. Austar may well end up taking over the Galaxy DTH service as they are now planning take-over of besieged and under funded East Coast TV. Foxtel will fight this at every turn and could try to launch its own DTH service (possibly on PAS-8) in response. Australia does not need three competitive over-satellite service providers!

More immediate is the unsettling news that while UEC and Panasonic and Sun Moon Star appear on an "approved IRD" list at Optus, as of our deadline (May 11), not one of these firms has signed a formal contract (order) with Optus for the IRDs. Optus now suggests June 6th is an official turn on date for digital RABS and September is the switch over target for all B-MAC to digital.

There are more loose ends than we can count. The fall over of Galaxy will not be complete until the financial receivers (and the inevitable court appeals) tell us it is all over. In the meantime, very unsettled conditions will continue to plague the Australian pay-TV world. In the worst scenario we can imagine, Galaxy will actually shut down its transponders leaving tens of thousands of home DTH viewers with dark screens and Austar (using the Galaxy satellite feed) equally disadvantaged. Just when you hoped it was over - *it is not*.



## THE 1998 SATELLITE EXPLOSION IN THE PACIFIC/ASIA!

**IN THE NEXT 12 MONTHS - More than 200 new programming services  
scheduled for turn-on in the Pacific and Asia!**

**Stay tuned with SatFACTS!**

- ENTER my 12 MONTH subscription to SatFACTS starting with June 15th issue (rates below)  
 ENTER my 36 MONTH subscription to SatFACTS starting with June 15th issue (rates below)

NAME \_\_\_\_\_  
Company (if applicable) \_\_\_\_\_  
Mailing address \_\_\_\_\_  
Town/city \_\_\_\_\_ Country \_\_\_\_\_

Amount to send: 1 year - NZ\$60 (inside New Zealand) / A\$90 (inside Australia) / US\$60 (outside of NZ and Australia) or 3 years - NZ\$120/ A\$210/ US\$150 if by cheque. **VISA** or **Mastercard**? See form below and return with order. Return to: **SatFACTS, PO Box 330, Mangonui, Far North, New Zealand** or if by VISA or Mastercard fax to 64-9-406-1083

**ALL SatFACTS SUBSCRIPTIONS ARE SENT VIA AIRMAIL - WORLD-WIDE!**

USE THIS FORM ONLY WHEN CHARGING ON VISA/MASTERCARD

Please charge my **VISA/Mastercard** as follows:

- ONE Year of SatFACTS MONTHLY (NZ\$60, A\$90, US\$60)  
 THREE Years of SatFACTS MONTHLY (NZ\$120, A\$210, US\$150)  
 SATELLITE TELEVISION: The Booklet (NZ\$10, A\$12, US\$10)  
 One Year of COOP'S TECHNOLOGY DIGEST (NZ\$125, A\$125, US\$125)

Indicate charge card type:  VISA  Mastercard

Name (as it appears on **VISA / Mastercard**) \_\_\_\_\_

**VISA/Mastercard** Number \_\_\_\_\_ - \_\_\_\_\_ - \_\_\_\_\_ - \_\_\_\_\_

**VISA/Mastercard** expiration date \_\_\_\_\_

**Instructions:** If ordering by mail, return this complete (3-part) card or a copy of same (to **SatFACTS, PO Box 330, Mangonui, Far North, New Zealand**); if order by FAX, send full card as a single sheet to **64-9-406-1083**

**SUPPLEMENTAL MATERIALS from SatFACTS MONTHLY: Order Form**

- SATELLITE TELEVISION:** The Booklet. Excellent introduction to home dish ownership for the layman, including major contributions from the father of geostationary satellites - famed science fiction writer *Arthur C. Clarke*. The perfect tool to help the satellite system seller explain home satellite TV to the layman consumer. From SPACE Pacific. NZ\$10/ A\$12 / US\$10, airmail.
- COOP'S TECHNOLOGY DIGEST.** For the really serious enthusiast, investor, business person in satellite television and allied leading edge technologies. Ten issues each year, jam-packed with information you will not find anyplace else. "Coop" routinely culls more than 60 publications world-wide, terribly expensive newsletters, Internet and his hundreds of private contacts to keep you right at the leading edge of technology on the REAL changes underway in telecommunications. Conveniently issued near the **first of the month**, creating an excellent time-line-filler between the mid-month issues of SatFACTS. Now in the 5th year, airmail world-wide. Normally NZ/A/US\$250 per year - for SatFACTS subscribers special **50% discounted** price of NZ/A/US\$125.



## OBSERVER REPORTING FORM - Due JUNE 5, 1998

- NEW programming sources seen since May 1st: \_\_\_\_\_
- Changes (signal level, transponder, programming content) in pre-existing programming sources since May 1st: \_\_\_\_\_
- OTHER (including changes in your receiving system): \_\_\_\_\_

NOTE: Please use P1 - P5 code when describing signal levels and receiver IF/RF settings.

Your Name \_\_\_\_\_  
Town/City \_\_\_\_\_  
Make/size dish \_\_\_\_\_ LNB \_\_\_\_\_ Receiver \_\_\_\_\_  
Your email address \_\_\_\_\_ if you have one!

MAIL TO: SatFACTS Monthly, PO Box 330, Mangonui, Far North, NZ or fax 64-9-406-1083

### email - DO YOU HAVE email CAPABILITY?

**AN EXCITING NEW SERVICE from SatFACTS is coming. And we'll give you just one clue: "It is NOT monthly!" If you have email capability, and would like faster updates - return this card!**

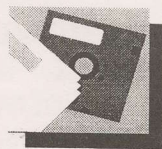

+

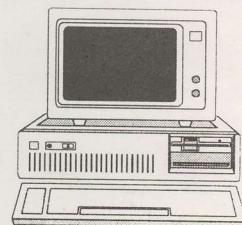

YES - I AM on-line with email!

email address \_\_\_\_\_

My name \_\_\_\_\_

Mailing address \_\_\_\_\_

Town/city \_\_\_\_\_

Mail or FAX this form to SatFACTS-Q, PO Box 330, Mangonui, Far North, NZ or fax to 64-9-406-1083

## SPACE INFO PACK?

Looking for the "inside track" to more sales and greater profits in satellite systems? The trade association SPACE Pacific may be able to help.

YES - Send membership details for SPACE Pacific to ...

NAME \_\_\_\_\_

Company (if applicable) \_\_\_\_\_

Mailing address \_\_\_\_\_

Town/city \_\_\_\_\_

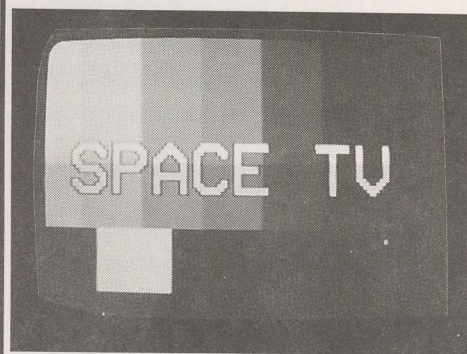

**SPACE Pacific Ltd.**  
PO Box 30, Mangonui, Far North  
New Zealand  
Fax 64-9-406-1083





## UNCLE BAYSAT ASKS ...

**Are your feeds getting too much ground noise, or, too little signal?**

The Free-to-Air **Sports Pacific Network** and **RFO 1 & 2 (digital)** on Intelsat 180 are true tests of whether a dish system is functioning properly or not. These right and left hand circular transmissions require a quality **circular** feed that ignores ground noise. Our ADL CP300 and CP400 feeds are proving themselves daily on these difficult SCPC services. Do you want Free-to-Air sports and multi-channel French?  
**See us for an ADL feed for your dish system today!**

NOBODY would purposefully point their satellite dishes directly into the ground expecting to receive satellite signals! YET - that is what you do if you select the wrong feed for your particular dish. No decision you make concerning packaging a DTH system is more important than the choice of the correct feed for the dish!

A FEED that OVER illuminates your dish might as well be pointing at the ground picking up terrestrial noise! Signal levels may measure good but your signals are buried in noise; not good!

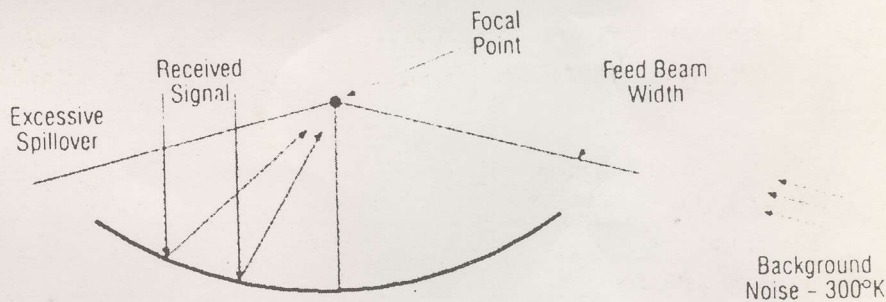

OR, a feed that UNDER illuminates the dish only receives from a portion of the surface, throwing away dBs!



Don't leave dBs behind at the dish - get all of the signal your system is capable of producing!

Uncle Baysat recommends and uses for our own installations the versatile ADL range of feeds - there is **ONE** correct feed for every dish installation - ADL makes it and Uncle Baysat has it in stock!

**AND -**

**BaySat has the hot new Palcom SL-7700RP in stock and available for immediate shipment. Own a Legacy!**

**YES!**

We STILL accept VISA, Mastercard with no surcharge!

## BAY SATELLITE TV LTD

PO BOX 3311 • Napier • New Zealand • Tel toll free 0800-BAYSAT  
International 64-6-843-5296 • Fax 64-6-843-6429 (0800-229-728)  
Physical location • 19B Carnegie Road, Onekawa, Napier  
<http://www.baysat.co.nz>  
e-mail [john@baysat.co.nz](mailto:john@baysat.co.nz)



**THE NEXT BEST  
THING TO BEING  
HARD WIRED  
TO THE BIRD...**



**... The Palcom SL-7900RP  
first choice of satellite  
experts, performance  
conscious installers and  
quality driven consumers  
across the Pacific and Asia.**

SL-7900RP: 500 channel memory Hi-Fi Stereo satellite receiver with full motorised actuator dish control built-in. Two IF inputs (950-2050 MHz); Standard 27/18 MHz IF bandwidths, plus 32 step threshold extension for signals as weak as 3dB C/N; Fully tuneable audio sub-carrier range (5.5 - 9.5 MHz) independent on L and R channels; Selectable wide (280kHz) and narrow (150kHz) audio bandwidth with J17, 50uS or Hi-Fi 1600 de-emphasis; Full polarizer control; TV modulator (E21-E69) + 3 SCART 21 pin outputs, separate L and R RCA audio outputs. Every function (including antenna, feed settings) logged into memory for instant recall - totally automatic channel search with companion handheld IR remote. Consistently rated by leading publications "Most versatile, low threshold, ultimate consumer receiver" world-wide. Truly, the next best thing to being hard wired to the satellite.

SL-7900RP from Bay Satellite TV Ltd, P.O. Box 3311, Napier, NZ. Tel 64-6-843-5296 (Fax 64-6-843-6429)

with software by....

**PALCOM**

State of the Art Simplicity