

12-03-98 11AM

Bob Cooper's

MARCH 15 1998

# SatFACTS

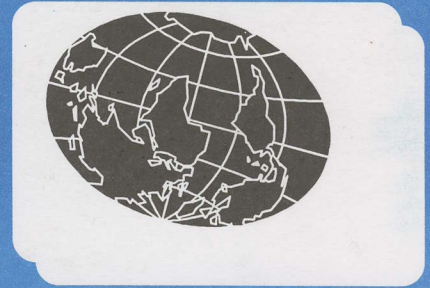

MONTHLY

Reporting on "The World" of satellite television in the Pacific and Asia

## IN THIS ISSUE

**THREE NEW  
MPEG-2  
RECEIVERS  
REVIEWED**

**Msym vs.  
Picture Quality -  
The Dilemma**

**The Show,  
The Slow,  
The S'truth**

- ✓ Latest Programmer News
- ✓ Latest Hardware News
- ✓ Latest SPACE Pacific Reports
- ✓ Cable TV Connection

**Vol. 4 ♦ No. 43  
Price Per Copy:  
NZ\$8/A\$9/US\$6**

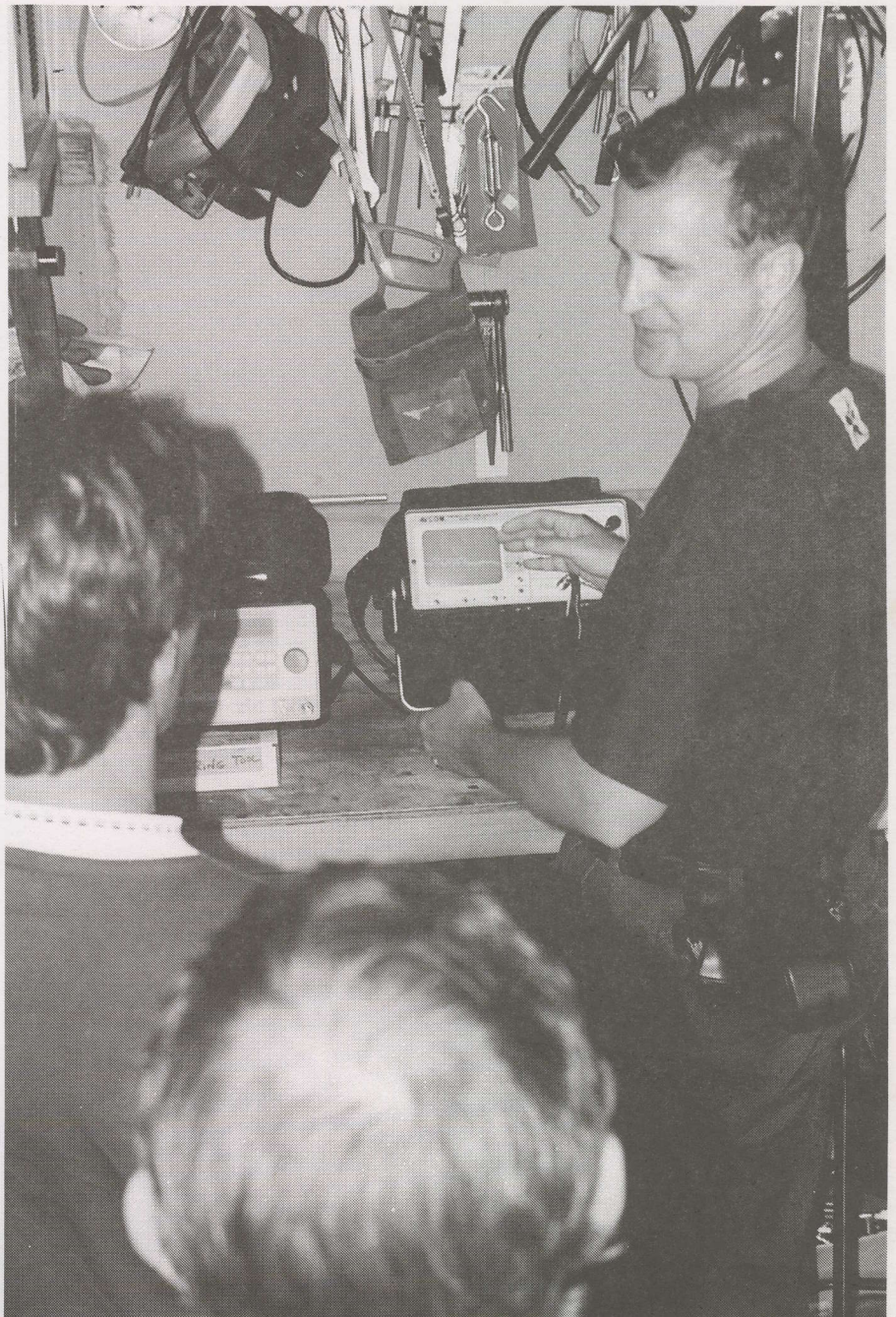

# Paraclipse<sup>®</sup>



When quality, strength, and accuracy are your main requirements, **Paraclipse** antennas are your first choice.

HYDRO  
SERIES

ECLIPSE  
SERIES

CLASSIC  
SERIES

Only **Paraclipse** offers such variety; four distinctly different series: the Truss-Ribbed Classic, the Courier Deliverable Eclipse, the Stretch Formed Hydro, the Commercial Patriot.

Every **Paraclipse** model sets the industry standard in its class, worldwide.

Distributed in Australia by  
**SKANDIA ELECTRONICS Pty. Ltd.**  
183 Burwood Rd, Hawthorn, Melbourne  
Tel 61-3-9819-2466 \* Fax 61-3-9819-4281  
Level 1, 39 Terry St, Rozelle, Sydney  
Tel 61-2-9555-2955 \* Fax 61-2-9555-2455

Distributed in New Zealand by  
**BAY SATELLITE TV Ltd.**  
PO Box 3311, Napier  
Tel 64-6-843-5296 Fax 64-6-843-6429

## Paraclipse<sup>®</sup>

HIGH PERFORMANCE ANTENNAS

★ **MADE IN AMERICA**

Paraclipse Inc.  
2271 29th Avenue East, Columbus, Nebraska USA 68601  
Telephone: (402) 563-3625 Fax: (402) 564-2109

# SatFACTS MONTHLY

ISSN 1174-0779

is published 12 times each year (on or about the 15th of each month) by Far North Cablevision, Ltd.

This publication is dedicated to the premise that as we enter the 21st century, ancient 20th century notions concerning borders and boundaries no longer define a person's horizon. In the air, all around you, are microwave signals carrying messages of entertainment, information and education.

These messages are available to anyone willing to install the appropriate receiving equipment and, where applicable, pay a monthly or annual fee to receive the content of these messages in the privacy of their own home. Welcome to the 21st century - a world without borders, a world without boundaries.

#### Editor/Publisher

Robert B. Cooper (ZL4AAA)

#### Office Manager

Gay V. Cooper (ZL1GG)

#### Reaching SatFACTS

Tel: 64-9-406-0651

Fax: 64-9-406-1083

Mail: PO Box 330

Mangonui, Far North

New Zealand

#### Subscription Rates

Within NZ: \$50 p/y

Australia: AV-COMM Pty Ltd, PO Box

225, Balgowlah, NSW 2093

61-2-9949-7417

Elsewhere: US\$60 p/y

All copies sent via airmail fast post world-wide

#### ERRATA

SatFACTS Copyright 1998 by Robert B. Cooper; any form of copying is a violation of our international copyrights. Advertising rate sheet available upon request.

## COOP'S COMMENT

The apparent willingness of SPN to slug it out island by island to create viewers for their free to air Pacific region sports and culture channel is a bright spot in the present negative world of DTH television for the Pacific. SPN is already feeling pressure from terrestrial and cable affiliates to expand to 24 hours daily (they pay rent for the Intelsat I180 spectrum space for full-time) and there are ambitious plans for affiliates throughout the Pacific to become originators of events to be fed back to SPN Nauru.

SPN's pockets will only be as deep as the willingness of the Government of Nauru to keep the service funded while the inevitable negative cash flow during start-up continues. Nauru's support can best be measured away from the island nation by the on-air look and feel of the service and by SPN's increase in facilities and on air presence. Let's look at some side possibilities.

SPN's present SCPC transmission to Intelsat 180 is, as we all now know, at a relatively low EIRP (effective radiated power) level. SPN cannot for a number of reasons significantly increase the power through the satellite so we have two options: (1) Accept the power level as it now is and build receiving dish systems to compensate, or, (2) Do everything we can to encourage SPN to move to another satellite with greater power and better coverage. One possibility, and SPN is talking with them, is the Orion 3 craft scheduled for October launch to 139E. Whether SPN would be best served by being on Orion 3 C-band or on Ku band will require extensive study - the Ku band argument is strong when you consider their 43 dBw footprint (SF#40, December, p. 2) takes in virtually all of the Pacific marketplace. Orion 3 on Ku band could create true DTH service levels with 1m range dishes for SPN from eastern Australia to Tahiti.

An equally important growth opportunity would see SPN change from SCPC to MCPC, and to over time add additional channels of programming. Few of us would complain if SPN, perhaps in partnership with others, created a pay TV movie channel, or arranged through satellite feed into Nauru, a general entertainment channel originating from the United States. By bringing in a Los Angeles television station for redistribution on Ku (or C band) DTH, SPN should be able to collect upwards of 50,000 paying home and commercial subscribers to a package of channels in the first 24 months of operation.

The FTA sport and culture channel is an excellent beginning, and the government of Nauru must be commended for taking an initiative which commercial broadcasters in the Pacific have to date totally ignored. But ultimately SPN will be sustained only by generating revenue which pays its operating costs because the government will not, cannot, be expected to fund something this expensive indefinitely.

To get SPN from where they are today to a position of financial independence and cash flow strength will require exceptional skills and careful attention to separating the often blue sky over hyped world of satellite TV from the real world of bottom line business acumen. Every one of us can help with this by being supportive, by championing SPN's successes and engaging in lateral thinking. SPN, alone, cannot survive but with the collective backing of an entire industry, they can only go from strength to strength.

#### In Volume 4 ♦ Number 43

The Show, The Slow, The S'Truth -p. 6

Msym Rate versus Picture Quality -p. 14

MediaStar D7 Review -p. 18

#### Departments

Programmer/Programing Update -p.2; Hardware/Equipment Update -p. 4;

SPACE Notes (Two satellites - one dish) -p. 20; Cable Connection

(line amplifiers) - p. 22; SatFACTS Orbit Watch -p. 24; MPEG-2 Tuning

Parameters -p. 26; Digi Notes Reference Information -p. 28;

With The Observers -p. 29; At Sign-Off (Aurora Update) -p. 32

#### -ON THE COVER-

Mark Long (right) at work. During SPRSCS '98 Advanced Satellite Technology course, Long concentrates on explaining the usefulness of a spectrum analyser in DTH / TVRO work.

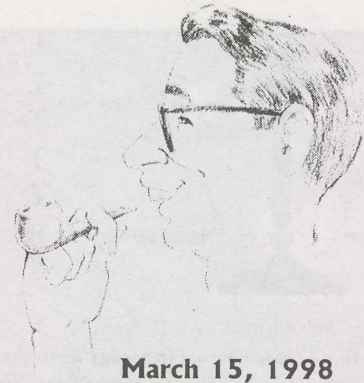

March 15, 1998

### Subscribing to PAS-2 PowerVu CA

"After returning home from SPRSCS '98, I checked the SPN signal on my 4.8m dish and Nokia 9500S receiver; it is solid here. With the Nokia, I have good reception of the California Bouquet and TCS Singapore from PAS-2 C-band. Are there other PAS-2 signals I should be able to receive in Tahiti? I am interested in subscribing to some of the conditional access services as long as the fees are not too high."

Gabriel Chinque, Papeete, Tahiti

Tahitian service on PAS-2 C-band is at best only marginal. In fact, the PAS-2 C-band coverage from Guam to Tahiti and points between does not fit their widely distributed coverage maps accurately. It is hoped PAS-8, to go to 166E late this year, will do a better job in that direction. As for CA access for DTH service, there are NO (CA) programmers on PAS-2 who have shown any interest in individual home subscriptions to date although most will deal with you as a cable TV or SMATV system operator if you can manage their (typical) minimum of 100 homes (connections) to cover their basic charges.

### Competition to MediaStar D7

"We have finalised the supply of our FTA IRD shown in the current catalog. In all, I have sought out and tested 32 different IRDs from all over the world. The unit we have selected is very similar to the Nokia, has all of the same channel edit functions, but no CA capability. And, it has a proper PAL modulator for our region of the world. I expect stock to arrive shortly and will arrange a test unit for review in SatFACTS prior to actual release. The unit will be a direct competitor to Opac's MediaStar D7."

Garry Cratt, AV-COMM PTY Ltd  
Balgowlah, NSW, Australia

Nokia really dropped the ball by failing to take advantage of their obvious lead in software technology with the original 9200 version receivers. We remain convinced they knew all along how to fix the NTSC / PowerVu "glitch" and were just too stubborn to do so. History may well record they were first to produce a receiver with the promise of being a "world standard" but the last to complete the job.

### Terrestrial TV 'FTA' Via Satellite?

"I live and work in the Waiiau River region of southern South Island. Our TV1 and 2 reception is very poor and TV3 and 4 are non-existent. New Zealand On Air and TVNZ try to maintain terrestrial TV through small regional translators but at best reception is poor and often the relay equipment breaks down for days on end. Is it true we will be able to get terrestrial TV relayed by satellite through Sky soon?"

T.K. Smythe

Sky told South Island people last August they would bring FTA services TV1 - 4 to satellite, then went silent on the project. There are problems. Sky has fewer digital programme channels available than they had hoped, making space for any terrestrial TV difficult. And, who pays for the DTH installation if you only want FTA terrestrial channels and will not subscribe to Sky? Is it worth upwards of \$600 (perhaps \$1,500) for an IRD to get FTA terrestrial TV to a remote home in Southland? Stay tuned.

## HARDWARE EQUIPMENT PARTS

## UPDATE

MARCH 15, 1998

**Mystery** copy of Hyundai or factory direct? Yuri, available primarily in Singapore, looks like, works like, a Hyundai twin. At somewhat less money. Software versions? At least through 2.25 if not further. Yuri "brand" also appears on LNBs and other products. Speaking of Hyundai - in Europe their DBS 3001 is Irdeto equipped, twin SCART sockets, video and audio RCAs. It looks like nothing else on the market but is not to best of our knowledge available in Asia or Pacific.

**Spokesperson** for AsiaSat tells SF, "Our best present estimate for launch of AsiaSat 3R (replacement) is second quarter of 1999. In the interim, we will be trying to accommodate channels on AsiaSat 2 and AsiaSat 1 until 3's replacement is available."

**Testing** began March 9th in Holland of two receivers which hope to win Irdeto certification allowing them to be used in Optus Aurora platform. Comstream (to be branded Panasonic in Australian marketplace) and UEC (once upon a time the same firm produced Panasats) engineering teams hand carried prototype receivers to Irdeto labs; results around 1 April. Optus cannot launch until 1 or more receivers have been certified by Irdeto for use in the Aurora branded service. For detailed report, see Coop's Technology Digest, March 4 as well as At Sign-Off, here.

"**Ipey bitsey** spider climbing up the feed." A "2 dB-loss spider" had set up housekeeping inside the throat of a Ku-band feed at Far North Cable TV causing signal outage on Optus B3 service for up to several hours at about the same time each day. First suspecting satellite or equipment problems, closer inspection revealed the spider was only camping inside the throat to escape the afternoon sun. When it cooled off to his liking, he left the throat and sure enough the signal would come back. The solution was obvious - one less spider in the world.

**TV5** transition to replace CFI on Palapa C2 was scheduled to happen March 4th; did not for reasons not explained, will still "happen" at some future date. TV5 is attempting to do closed captioning to allow English (for a start) subtitles on some programming. This is a technical problem or two still to be resolved but if (or when) it works, closed captions will transmit within digital data stream, not as digital teletext. Programme "Paris Lumiere" has been English captioned for test purposes.

**Sky Network** (NZ) has decided their uplink conditional access will be supplied by Murdoch controlled NDC but remains undecided about an IRD supplier. They have made formal a delay to "September" for earliest possible start-up of commercial digital satellite service but are equally uncertain how many programme services will share their 54 MHz wide Optus transponders. One executive claimed "15 per transponder" in a recent interview, which staff quickly reduced to "fewer than 12, maybe only 8, initially." Don't wager any money on September.

**JET-TV** (PAS-2, PowerVu) warning to affiliates: "15 minute interruption to our service is for download of new software to your receiver, during which video & audio will disappear. DO NOT TOUCH YOUR RECEIVER during this period; after download, receiver will resume normal reception."

### Experience Counts for Something

Have you figured out a way to accomplish some goal in TVRO which you believe to be new, unique or just plain better? SatFACTS urges you to set what you have done down on paper, illustrate with a sketch or photos as Roger Woodward has done (see p. 20, here) and send the material along to SatFACTS for sharing with the industry!

# ADL<sup>®</sup>

BECAUSE PERFORMANCE IS ALWAYS YOUR FIRST PRIORITY

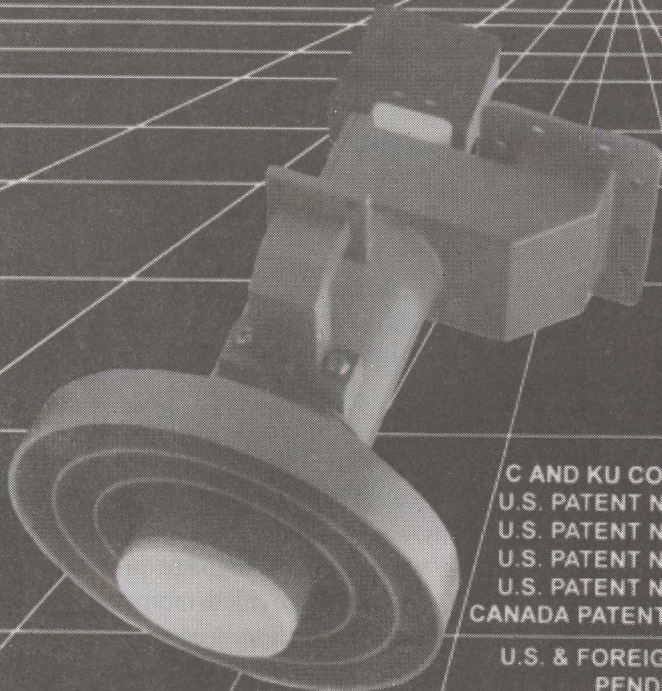

**RP3-CKU/ International  
Adjustable Scalar Ring Feed  
with Extended C Band**

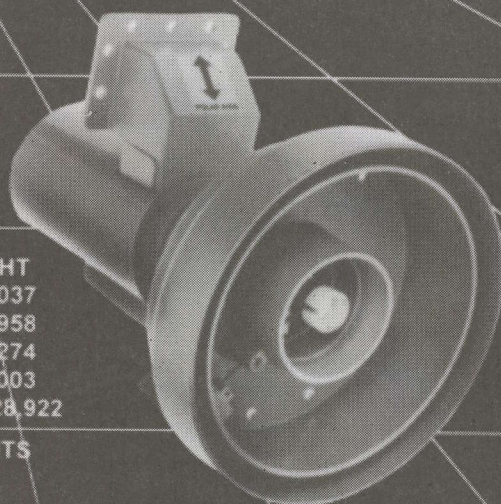

**RPI-CKU Feed**

C AND KU CO-BORSIGHT  
U.S. PATENT NO. 4,903,037  
U.S. PATENT NO. 5,066,958  
U.S. PATENT NO. 5,107,274  
U.S. PATENT NO. 5,255,003  
CANADA PATENT NO. 1,328,922

U.S. & FOREIGN PATENTS  
PENDING

## ADL HYBRID MODING CIRCULAR POLARIZED INTELSAT FEEDS WITH EXCLUSIVE T.I. REJECTION



**RP1-CP400**

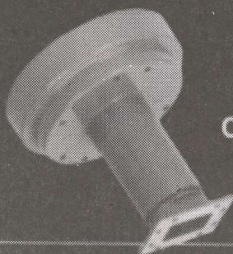

**CP-300**



**CPOR-100**

- C BAND LINEAR & CIRCULAR • C/KU LINEAR & CIRCULAR • KU 12 GHz FEEDS
- INTELSAT 4 GHz CIRCULAR • ARABSAT S BAND FEEDS
- OPTIONAL: CO-BORSIGHT S BAND

2216 AGATE COURT, UNIT B, SIMI VALLEY, CALIFORNIA 93065 • (805) 526-5249 • FAX (805) 584-0634

E-mail: [ADL@thegrid.net](mailto:ADL@thegrid.net) • Web site: <http://www.thegrid.net/adl/>

five channels of programming, designed to serve people  
who for whatever reason live where terrestrial TV is

## The SHOW, The SLOW and The S'Truth

It was the smallest turn out in the history of the annual South Pacific Region Satellite & Cable Show (first held in 1994). There was no formal exhibit hall (on purpose) although clever suppliers managed to create display areas in unlikely locations and one exhibitor from Germany proudly showed off his LNBFs operating under water.

This year's show was all about technology, the kind you can only grasp when you touch it, turn the knobs yourself, get hot, grimy and fatigued from toiling in the hot summer sun. In four days time the average attendee consumed 18 cans of cold soft drink from the constantly refilled coolers. Some took our advance warning and came prepared with hats and sunscreen; those who did not wished they had by Friday afternoon.

The TVRO industry has changed significantly from 1994. SatFACTS number one (September, 1994; issued to mark the first show) reported "Two new (Rimsat) satellites have come to life at 130 and 142.5E" Programming included Muslim Television (130E) and Asian Television Network (142.5E). The only other free to air programming was CNN + WorldNet + RFO (all on I180). The first PAS-2 service, Country Music

Television, did not begin operation until October 5 (they were FTA analogue initially). There was no Palapa C1 nor C2, no AsiaSat 2, no digital (until early 1995). A "small" dish was anything under 3.7 metres in size and because I180 (as well as the Rimsats at 130 and 142.5) were operating inclined orbit, the dish system required two tracking motors - one for azimuth changes, one for elevation. It was going to be difficult building a TVRO industry in the Pacific given these circumstances.

PanAmSat 2 was forecast to change all of that; a stable satellite capable of serving dishes as small as 2.4m in size on favoured transponders. What was unclear in 1994 and 1995 became painfully evident by 1996; PAS-2 was not going to be a DTH satellite and satellite customers would make that decision by withholding their programming for direct to home (DTH) access.

AsiaSat 2 (December 1995) would change this situation by offering the European Bouquet line-up of ethnic programming and ultimately a handful of others. What was lacking was English language programming and although PNG's EMTV provided momentary relief (from April 1995 until it disappeared into PowerVu oblivion late in 1997), the primary need was not



Receiver comparisons - Hyundai expert Stu McLeod (left, centre with cap) points out D9223 Bootload warning to Peter Kell (centre) and close watching attendees

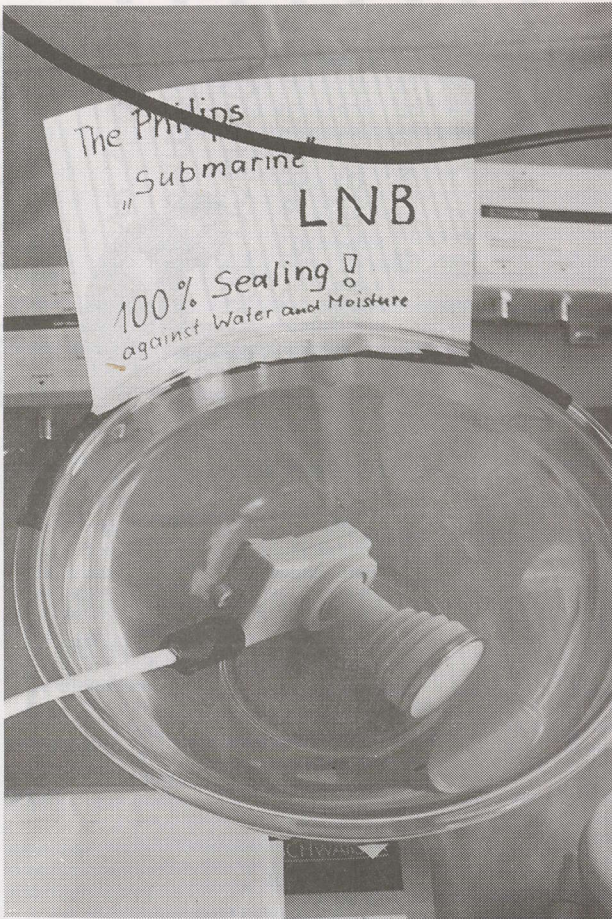

First you design an LNB and fittings that are waterproof (yes, that is a real bowl of water!) ...

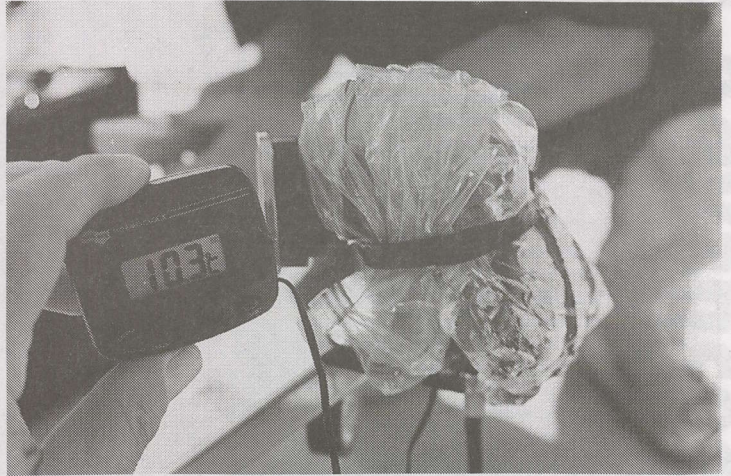

Then you wrap the LNBF in a plastic bag of crushed ice and measure the melting water temperature.

serviced. Palapa C1 went into operation in March 1996 from 113E after a four month launch delay, and for a few months there was considerable enthusiasm generated by first-time strong signals that played on dishes even under 2m in size. *Then* reality set in; most of the programming was in a language of no value to most viewers, and there was a hiccup. C1 was flawed and in June 1996 it was replaced with C2 at 113E. C1 was moved off to 150.5E and some testing aside, it has not been heard from since that time.

Through this two year period the Rimsat's eventually became less desirable as their inclined orbit travels hampered serious viewer interest, programmers left and now neither Rimsat remains at its original position established in 1995. JcSat-3 at 128E briefly promised to be useful, and testing revealed it could serve 3m size dishes on C-band in the Pacific. Alas, no programmers came to the party and JcSat's technical capability remains unused on C-band for the Pacific.

"The next satellite," it seemed, was always destined to be "the big one"; the "saviour" of a DTH industry for the South Pacific region. *"What we need to be viable"* laments John Lynam of BaySat, *"is a movie channel, a sport channel, some general entertainment programming and a news service; all in one place in the sky, all requiring one receiver to access."* Four, perhaps five channels of programming, designed to serve people who for whatever reason live where terrestrial TV is

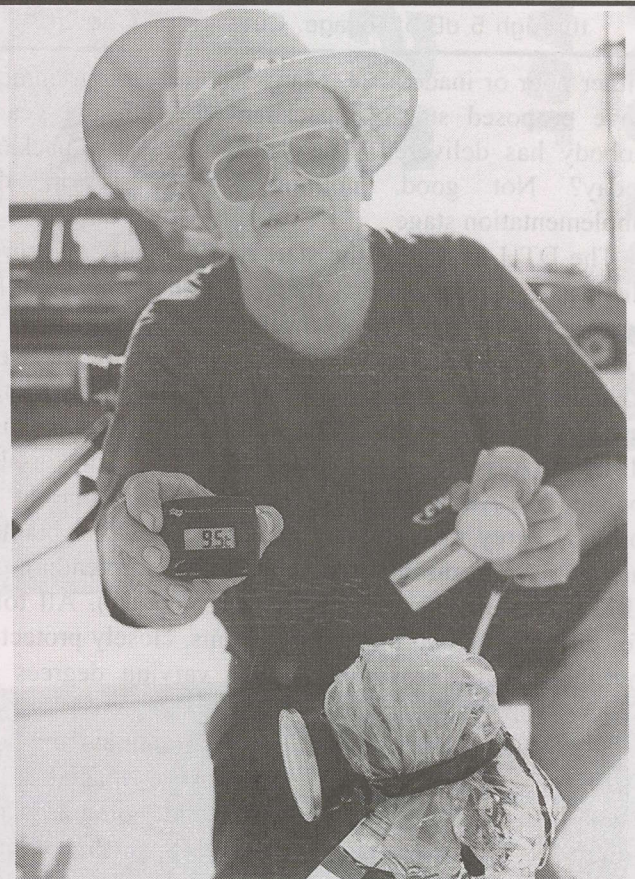

Horst Wieser and "super cooled" LNBF (see text).

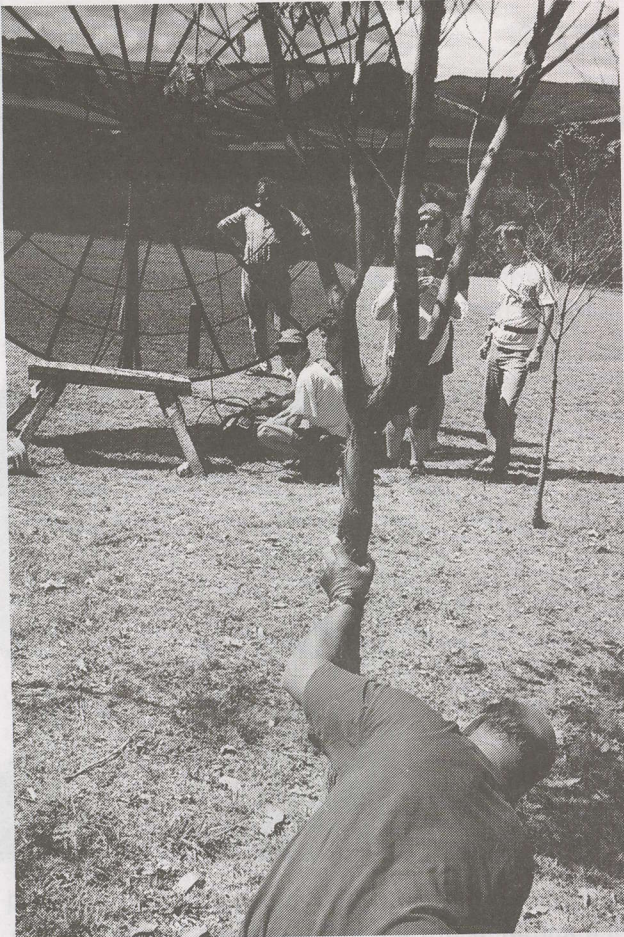

3.7m Orbitron at 13 degree look angle was looking through 5 dB of foliage. Cut the trees down.



1.2m Paraclypse proving itself at 5 degree look angle on AsiaSat 2 services from European Bouquet

either poor or inadequate. Many would be programmers have proposed such a "package" through the years; nobody has delivered. The status of such a package today? Not good, nothing serious is in the implementation stage.

The DTH market at the start of 1998 falls into three distinct categories. First there are the commercially served DTH consumers through packages such as Galaxy/Australis (Australia) and Sky TV Network (New Zealand). Dish sizes vary from 60cm to 1.2m in the primary areas, up to 2.4m in the "fringe" coverage districts. Adventuresome installations up to 5m in size outside of Australia, New Zealand have gone in to provide "grey market" service (through IRDs obtained and authorised through the subterfuge of pretending the IRD is actually located in the host country). All told, fewer than 100,000 total dish systems, closely protected by the service providers and in varying degrees of financial and/or engineering jeopardy.

The second market is for ethnic programming and here Australia is the centre of activity. An estimated 8,000 home dish systems, virtually all C-band, going after the European Bouquet (Italian, French, Spanish, German and perhaps one day soon, Greek) on AsiaSat 2 as well as a smaller level of interest in Japanese (NHK) and Chinese (CCTV plus the large number of SCPC services

on AsiaSat 2). Around the fringes, identifiable markets for Russian (which remains nearly impossible because of the inclined orbit, ageing Gorizont satellites), Indian (which currently is essentially not available except in Western Australia), Filipino, Thai, and Bahasa (Malaysia and Indonesia). At the extreme edges, too small to measure, limited interest in Mongolia, Myanmar (Burma), Egyptian, Portuguese, and Lebanese programming. Some dealers are making a living out of ethnic DTH, but not very many.

Group number three is the most vocal, perhaps out of proportion to their actual numbers. "Enthusiasts" (or hobbyist) TVRO system owners are on the leading edge of technology, anxious to have the latest in digital IRD hardware and software, and excited with every new service that comes along. Increasingly, mixed in are people with limited (or no) interest in television via satellite, but who find satellite Internet delivery equally fascinating. The distinction between "enthusiast" and dealer is also blurred because many who start out as enthusiasts find themselves installing dish systems for consumers because of their "local expert" status. How many enthusiasts might there be, out there? The subscription rolls for SatFACTS suggests far fewer than many would estimate; under 2,000 spread across the region from Tahiti to Western Australia.



# The Most Advanced Free To Air Digital Satellite Receiver **D7-MediaStar**

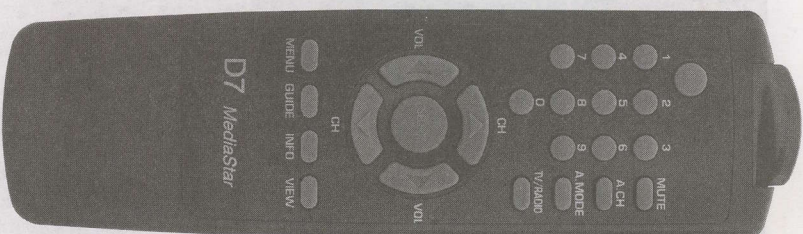
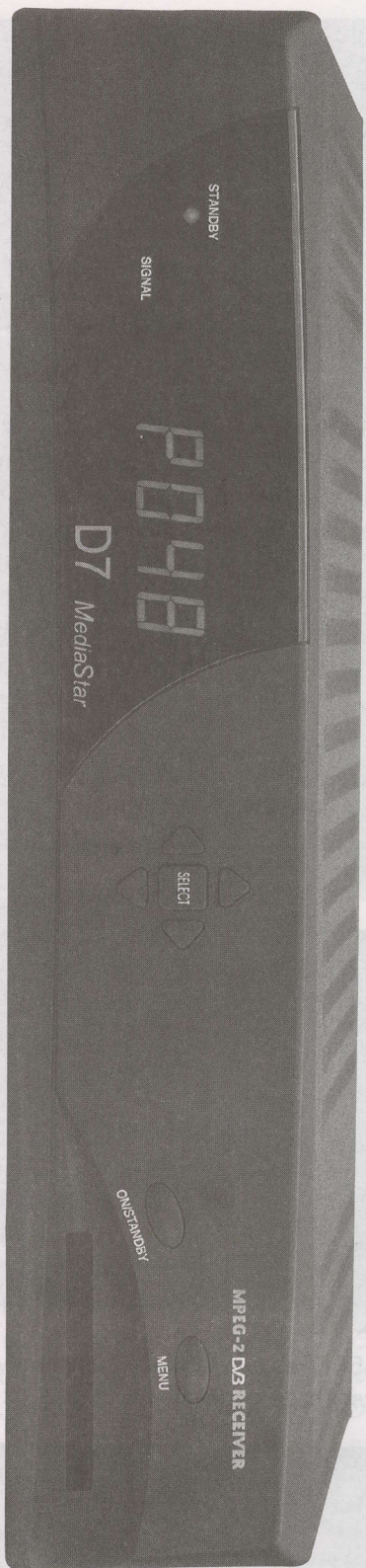

- MCPC/SCPC 2-36 Msym
- Direct channel selection from channel list
- Channel Edit menu Delete, Skip, ON.
- Fast response when changing channels
- No channel over-write
- 200 Video 100 Audio channels
- Automatic search and download
- 22 KHz switch
- PID Menu
- NTSC/PAL Auto switching NO NTSC Glitch
- NTSC converted to PAL-60Hz Free Option
- Audio L, R, Stereo selectable via remote control
- RF Modulator PAL-G, VCR/TV Scarts, RCA Audio/Video, SVHS outputs.
- 90-265VAC-50-60Hz power supply
- Low threshold performance

Opac Pty Ltd  
99-105 Boundary Road  
Peakhurst NSW 2210

E-mail [opac@bigpond.com](mailto:opac@bigpond.com)  
Tel ++61 2 9584 1233  
Fax ++61 2 9584 1452

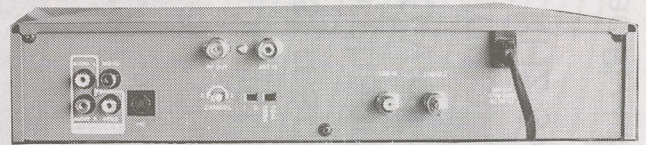
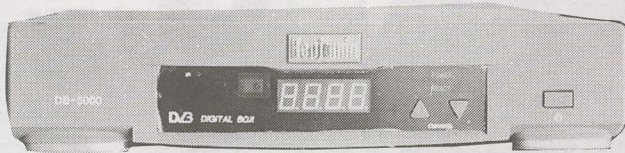

Benjamin MPEG-2 FTA DB-5000 is straight forward unit that includes RF (L-band) loop-through on rear panel. How did it work? Another time, another place.

So is there a business here? That was the number one question on the minds of those attending SPRSCS '98. The question would come easier than the answers.

*Antennas.* Prices are stabilised after small but steady reductions during the past two years, and have recently risen by as much as 15% in reflection of the changing value of Australian and New Zealand currency against the benchmark US dollar. Some product continues to come in from Taiwan, it is typically lower in quality (and cost) than the American counterparts. The warnings here: Dishes over 3m size which originate outside the USA are probably a gamble. Pieces do not fit properly, hardware quickly rusts and corrodes, dish surface integrity is difficult to "prove" (make right). European dishes up to 1.2m in size recently seen (including

SPRSCS '98) have two advantages: Their quality is equal to or better than the American product, and, in container load shipments, they are as much as 50% less costly than the American dish products. This has a bearing on the future growth of the category one (home DTH) market, it could have some importance to the category two (ethnic) market.

Within SPRSCS '98 was a real world demonstration of the shadowing effects caused by a pair of five year old Eucalyptus trees (see p. 8). An Orbitron 3.7m dish was lowered to see Palapa C2 (a 13 degree look angle). Two gum trees created approximately 40% shading. The signal level was read on a spectrum analyser, and tree one cut down. Instant increase of 2 dB. The second tree

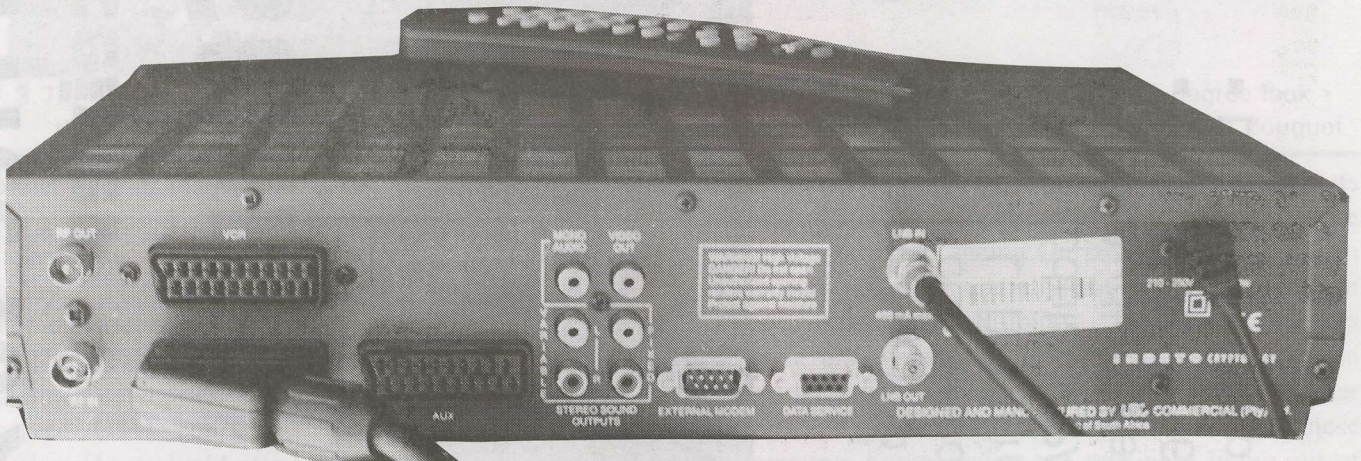

NOT last year's 520/630/635! The new UEC 642 is totally new from stem to stern, building on the hard learned lessons of the first three generations of this ex-Panasat design. (Galaxy software below)

				<b>TV Guide - Public Bouquet</b> <span style="float: right;">20/02/1998 10:35:55</span>	
<b>PAY PER VIEW EVENT</b> <b>Superbrawl VIII</b> 23 February 1998 Live 11:00am ESST Replay 6:30pm ESST To order at \$19.95 call Galaxy 1 300 300 445 Auster 1 324 32 before 22 February 1998 <small>Galaxy &amp; Auster Subscribers only</small>				13 PVW PREVIEW CHANNEL 22:30 13:43	2 Audio Guide
				14 CMT NON STOP COUNTRY 03:00 15:00	TV TV Guide
				15 TNT WCW NITRO 10:00 12:00	NOW NEXT
				16 16 03:00 15:00	DStv
				17 NWTV BEFORE DAWN 10:20 11:05	
				18 MVIE ERMO 09:55 11:30	
NOW SHOWING ON GALAXY				18	
Press the info button for more information Press OK to tune to this programme					

\* Coop's SPRSCS '98 RETREAT \*

TP:42

NO LOCK !  
INVALID SETTINGS or POOR CNR.  
CHECK SatFACTS MPEG2 DETAILS!

TP:41

Any Vacancies @ Media Lab 1 ?

HYUNDAI

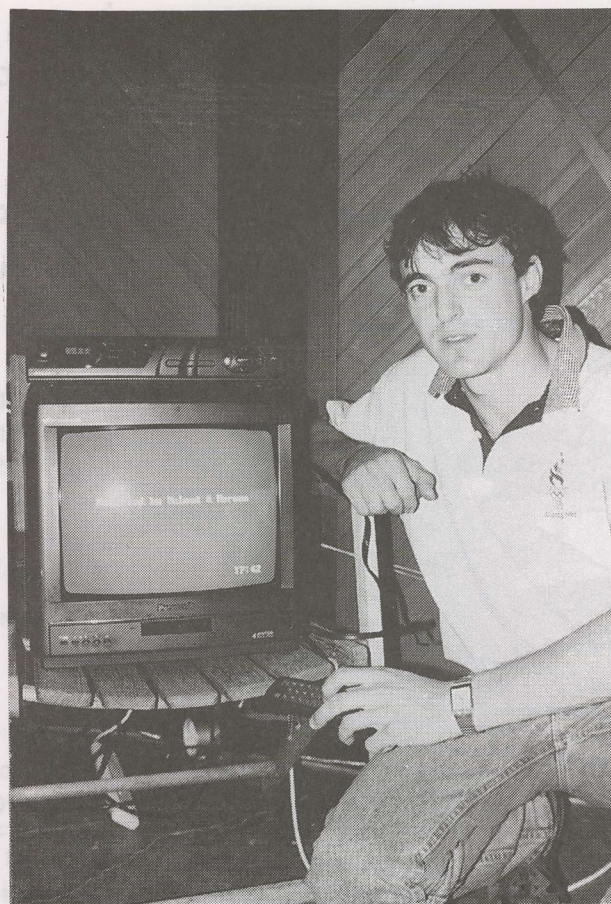

Stu McLeod and his "cracked" Hyundai software. Now that he is "inside" the data stream, creating his own text messages is a piece of cake.

was cut down; 3 more dB for 5 total. Good-bye trees, hello satellite TV!

*LNB/Fs.* Prices continue to tumble; Singapore sources list 17 degree, wideband (3.4 - 4.2 GHz) rated LNBs under US\$20 (in quantity); at Ku band a consumer threshold in the region of 90 degrees (1.2 dB as Ku band LNBFs are marked) has appeared in the US\$30 range. C-band LNBs have reached a noise temperature plateau limited by the materials used and the mechanics of low noise amplifier design. Ku LNB(F)s with noise temperatures below 1 dB (75 degrees K) are available at premium prices and the lowest "claimed" at consumer DTH region pricing is around 43 degrees Kelvin (0.6 dB). One way to improve the performance on any LNB is to operate it at a cooler case temperature. Horst Wieser from Germany delighted SPRSCS '98 attendees with his two-day demonstration of how this is possible (if not practical in the real world) by partially filling a plastic bag with chopped ice, wrapping the ice filled bag around the Ku band LNBF and showing off reception which was simply not possible with a normal "air cooled" LNBF (see photos, p. 7). With a thermocouple in the water, a thermometer tracked the melting water temperature which encased the LNBF. Using PAS-2 Ku with a 1m antenna and 1.2 dB LNBF, there was no reception on a digital service channel. When the LNBF was "ice water cooled" to 10C or below, the digital reception played fine. It should be noted that cooled

LNBFs are available in the commercial field - you don't want to ask the price (!) but if you can figure out a way to daytime-cool an LNB/F on a marginal system, you will not be disappointed with the results.

*Receivers.* We have not seen the last of analogue or new analogue receiver technology. Benjamin, Palcom and others are increasing the features and lowering the prices simultaneously; something that could not have happened even one year ago. Blame it on the digital world explosion which is driving the majority of receiver research and development these days.

Service specific IRDs will continue to be a thorn in our sides for several more years. Cagey programmers, forced to subsidise (pay part of the cost of) IRDs to get them into homes so people will subscribe is at the root of the problem. Subsidising IRDs has all but bankrupted Galaxy/Australis, and Sky NZ is headed down the same trail later this year. When a programmer pays US\$350 for IRDs, charges under US\$100 for their installation, and carries the balance (US\$250) of the cost on his books as a subsidy to encourage people to subscribe to his US\$30 per month programming package, he is assuming a sizeable debt load. The programmer hopes to make up the US\$250 difference "over time" from profits out of the monthly programming revenue. If, after paying the cost of programming and satellite delivery he



THE THEORY (Mark Long teaches Digital Basics at left) and THE PRACTICE (retrofitting a 3.7 metre solid dish for optimised single polarity feed at Far North Cable TV headend as a hands on experience).

has \$5 "profit" per month, and all of that is assigned to pay off the receiver debt, it will take the programmer 50 months to get his receiver debt paid off. There is not a very good business plan here, yet smart programmer after smart programmer falls into this trap

This is "the year" of FTA digital IRDs. The early Nokia models, the later Hyundai units were but the first wave of what promises to be an overwhelming selection of FTA IRDs by years end. A few - very few - will handle dedicated service packages (Australis/Galaxy) and free to air MPEG-2. The UEC 642, now undergoing Irdeto certification testing in Holland, is one of those. The Optus Aurora platform is one of the first in the world to break with tradition and insist that receivers for this service do more than their own bouquet and to encourage more than one receiver supplier to build to this set of standards. We can but hope this philosophy catches on, that the days of proprietary systems (in

particular the Scientific Atlanta PowerVu) are numbered.

The new MediaStar D7, the Benjamin DB 5000, a new digital IRD from Palcom and more than a dozen others are the next wave of consumer oriented digital IRDs. New designs have preloaded menu selection of individual services speeding up installation and eliminating the opportunity for error. Sensitivity (threshold of tuner) and operating speed will determine which models will succeed in the marketplace and as the recent Hyundai version 5.0 has shown us, threshold on weak signals will continue to be "number one."

Nobody will get rich this year; there are too many problems, too many unknowns. The Aurora project will provide the best business opportunity in Australia for equipment sellers and installers; in New Zealand, wiring homes and commercial premises for L-band distribution in support of Sky's digital expansion will be a significant business challenge.

## small, medium and LARGE C and Ku antennas in stock!

Transmit and receive antennas from 1.2m to 13m (Intelsat Standard B). Linear and circular feeds (AsiaSat, Palapa, JcSat, Rimsat, PanAmSat, Intelsat and more) for transmit and receive-only applications. Receive and transmit electronics including inclined orbit tracking equipment with motor drives for elevation and azimuth to 50 tons. Complete system design, fabrication, installation + proof of performance.

P  
A  
C  
I  
F  
I  
C



Limited

A  
N  
T  
E  
N  
N  
A  
S

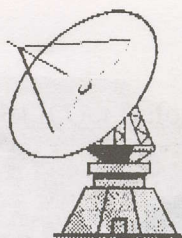

**SATECH** SATELLITE COMMUNICATION TECHNOLOGY P.T.Y. L.T.D.

A.C.N. 081 706 729

**AT LAST A SATELLITE EQUIPMENT SUPPLIER WHO HAS THE BEST EQUIPMENT AT THE RIGHT PRICE**

**DISTRIBUTORS FOR**

HYUNDAI DIGITAL RCVRs  
PARACLIPSE DISHES  
STRONG ANALOGUE RCVRs  
GARDINER LNBs  
CHAPARRAL LNBs  
VENTURE ACTUATORS

CHAPARRAL VISION  
THE NEW BREAKTHROUGH IN C-BAND DUAL POLARITY VOLTAGE SWITCHING LNBs.  
20K EXTENDED BANDWIDTH, LOW PHASE NOISE, DIGITAL READY.

SPECIAL INTRO PRICE **AUST \$97 + Tax**

**NEW PRODUCT  
SRT7000 STRONG**

Analogue Receiver / Positioner  
Low Threshold Tuner (3.0 dB C/N).  
600 channels, 50 satellite positions,  
2 IF inputs, 900-2100 MHz C/Ku band,  
On screen 4 digit LED display  
Scan Function, DNR 5-band equaliser  
Adjustable audio bandwidth, 14/18V & 22 kHz switching,  
0/12V external switching mechanical polariser  
9 RCA A/V connectors, 21-69 UHF PLL modulator,  
8 event timer, parental lock, data down loading

**AUST \$349 + TAX**



TRADE PRICES  
FOR QUALIFYING  
TRADE INSTALLERS

**HYUNDAI HSS-100**

Latest Factory Approved 2.26 software, high sensitivity TV/COM tuner. B/G adjustable UHF modulator. Heavy duty power supply, fan cooled for reliable operation. Full factory approved backup!

**OPENING SPECIAL**

**AUST \$599 + Tax**

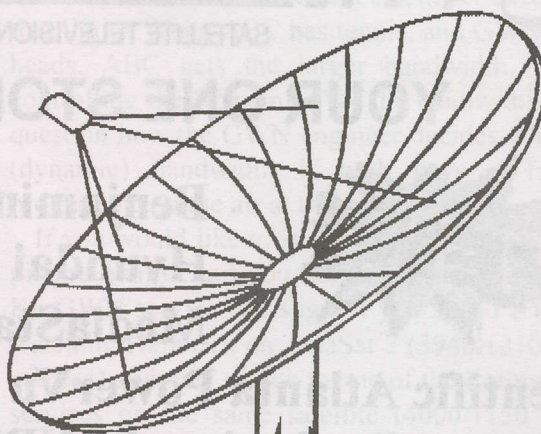

PARACLIPSE 2.6 Mtr

The world's most universal and best performing under 3m dish on the market!

**AUST \$540 + Tax**

**SATECH** SATELLITE COMMUNICATION TECHNOLOGY P.T.Y. L.T.D.

6/477 WARRIGAL RD MOORABBIN EAST VIC 3189 PH 61 3 9553 3399 FAX 61 3 9553 3393

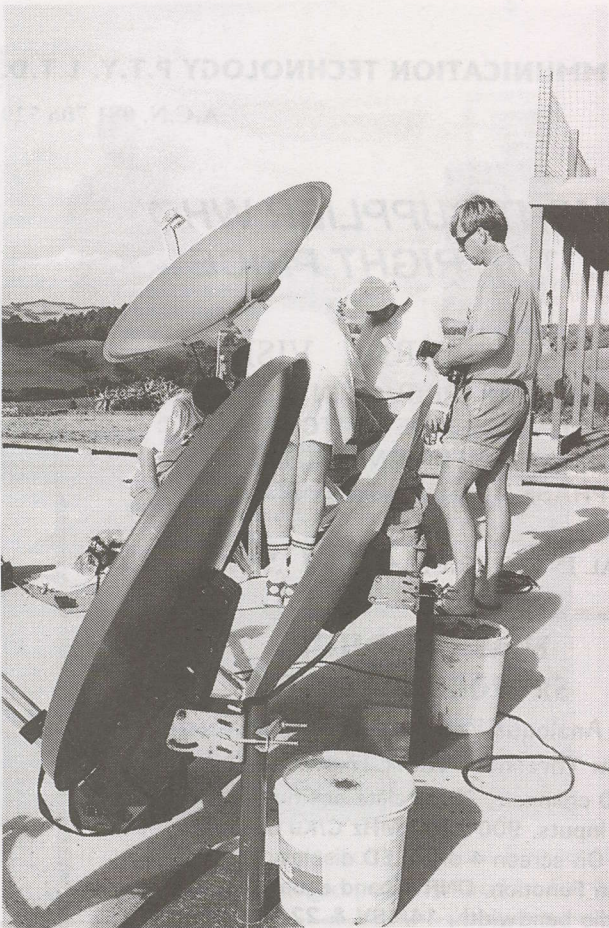

FINDING A SHADY Spot? There was a lot of bending over small boxes on the ground, sitting beneath inverted mushrooms as attendees related dish size and satellite EIRP to actual picture quality.



## TELSAT™ COMMUNICATIONS LTD.

SATELLITE TELEVISION CONSULTANTS, IMPORTERS AND EXPORTERS

### YOUR ONE STOP DIGITAL SHOP

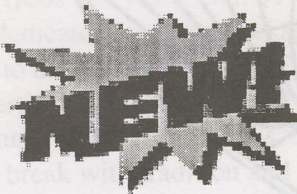

Benjamin DB-5000 IRD NZ\$734.48

Hyundai HSS-100-C IRD NZ\$899.00

MediaStar D-7 IRD NZ\$995.00

Scientific Atlanta PowerVu™ IRD'S POA

Cal-Amp Professional LNB's & Line Amp's POA

Mark Long's Latest Book-Best Yet! NZ\$40.0

All prices exclude GST and Freight Special conditions apply

Please Visit our Comprehensive WEB site  
Contact us for your FREE 24 page catalogue

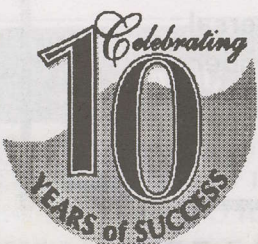

17 Westhaven Grove, PO Box 1537, Palmerston North, New Zealand.  
Tel: 0-6-356 2749, Fax: 0-6-355 2141, Int'l: +64-6-355 2141, Cellular: 0-21-454 945, Freephone: 0800-TELSAT  
Internet Email: [telsat@intec.gen.nz](mailto:telsat@intec.gen.nz) Web: <http://www.telsat.com>

## Msym vs. PICTURE QUALITY - THE DILEMMA

*Quick review:* Digital picture quality depends upon a number of factors which can be generally summarised by the Msym (megasymbol rate). Digital works in transponder bandwidths which are far too narrow (small) to transmit an analogue picture. It does this by compressing the signal in three different ways. Software engineers (people who write computer programming) are driven by an obsession to compress the programme information so that each TV programme channel occupies as little transponder space as possible. The "winner" in this high tech game will get his name in a history book, and large royalty cheques from every firm that uses "his" software.

Satellite programmers, including Internet providers, are keen to be associated with the software engineer who wins this race to "ultimate compression." Why? Because they typically rent a transponder (or portion thereof) by the megahertz of bandwidth they require to send their SCPC or MCPC service. If someone creates software that allows programmers to cut in half the amount of transponder space needed to send a TV programme, they save big rental amounts by using less satellite bandwidth.

There are undesirable artefacts to compression. Too much compression and a picture begins to look "smeared"; not unlike a bad VHS tape copy. If the action on the screen is fast, the images begin to "jerk" rather than flow smoothly (like a sequence of badly timed stop motion images one after another).

Over zealous compression salesmen down play these artefacts: careless or under informed compression software buyers (programmers) are so rapt with the bandwidth they will save that they rationalise "nobody will notice the lower picture quality."

Fast forward now to the ABA Seminar held in Canberra (Australia) late in February and a discussion about the merits of compression technology. Part of the festivities was a tour of the DOCA test labs and there attendees saw an extremely interesting side-by-side demo of a 2Mbits/s MPEG2 test signal and a 6Mbits/s MPEG2 signal. Watching the 2Mbits/s on its own seemed to indicate a reasonable quality image, *until* you simultaneously looked at and compared this transmission with the 6Mbits/s signal carrying the same video information. If the video information was a fast moving sport such as tennis or motor sport, or, the signal had a ticker tape running across the bottom of the screen, it was quickly apparent to every eye seeing the demonstration that 2Mbits/s was a very poor second in image quality.

A Telstra sales executive was present during one of these sessions when a DOCA engineer explained that the 2Mbits/s service was what Telstra is currently providing for the so-called 'ABC Companion Service' now being broadcast in Western Australia by the GWN/Telstra/Scientific Atlanta. There have been complaints about the quality of the 'ABC Companion Service' and more importantly, when this 2Mbits/s service is rebroadcast through a terrestrial VHF or UHF relay transmitter to a remote community, the VHS-like quality of the data stream suffers further. The DOCA engineer at the ABA meet took this opportunity to draw attention to this "compression decision" and suggested that GWN+Telstra+SA were getting away with this low quality ABC service "only because people have never had the opportunity to see how good the same service could look at a higher Msym rate (such as 6Mbits/s)."

GWN's response, after the fact, is to claim they are "dynamically multiplexing GWN and ABC services." That means that someone, a human being, sits in front of twin monitors and watches the programme content for GWN and ABC. When GWN switches to a motor sport, up goes the bandwidth for GWN, down comes the bandwidth for ABC (the amount of total bandwidth available is finite and the sum can never exceed 100% of that limit). When ABC has tennis, and GWN has talking heads, ABC gets the larger bandwidth. With GWN controlling the "dynamics" of the bandwidth, one has to question how the GWN engineer decides who gets what (dynamic) bandwidth if both have a fast moving programme on the air at the same time.

If you would like to study the impact of bandwidth on picture quality and you don't have access to the PAS-2 Ku GWN service, we suggest you spend a few minutes watching Hallmark on AsiaSat 2 (3940/1210 Vt; 26.655 and 3/4) and then switch to one of the European bouquet services on the same satellite (4000/1150 Hz, 28.125 and 3/4). If possible, put both up simultaneously on two receivers and monitors. The Hallmark picture is acceptable until you put something with greater bandwidth next to it, and then you realise that Hallmark at best is VHS quality and often not very good VHS at that. (In case you wonder why with a Msym of 26.655 the bandwidth is so small for Hallmark, remember this is the Msym for the ZakNet *Internet* delivery service and Hallmark is but a tiny portion of that data stream.)

Bottom line? Telstra has cheapened the ABC product with SA's help and the loser is the consumer.

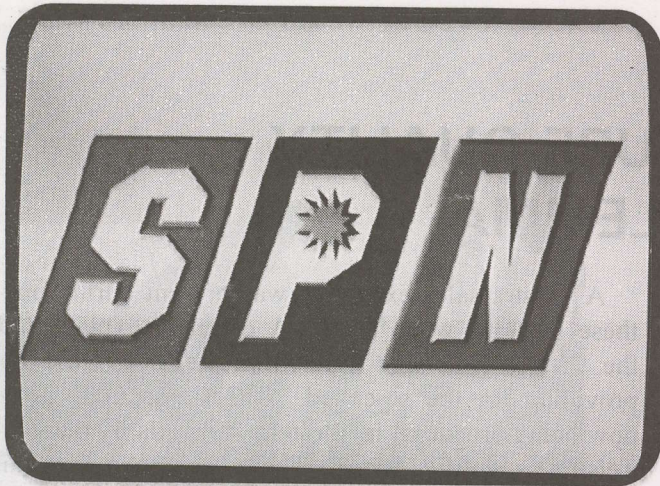

## UNCLE BAYSAT ASKS ...

**Are your feeds getting too much ground noise, or, too little signal?**

The Free-to-Air **Sports Pacific Network** on Intelsat 180 is a true test of whether a dish system is functioning properly or not. This right hand circular transmission requires a quality RHC feed that ignores ground noise.

Our ADL CP300 and CP400 feeds are proving themselves daily on this difficult SCPC service. Do you want Free-to-Air sports?

**See us for an ADL feed for your dish system today!**

NOBODY would purposefully point their satellite dishes directly into the ground expecting to receive satellite signals! YET - that is what you do if you select the wrong feed for your particular dish. No decision you make concerning packaging a DTH system is more important than the choice of the correct feed for the dish!

A FEED that OVER illuminates your dish might as well be pointing at the ground picking up terrestrial noise! Signal levels may measure good but your signals are buried in noise; not good!

OR, a feed that UNDER illuminates the dish only receives from a portion of the surface, throwing away dBs!

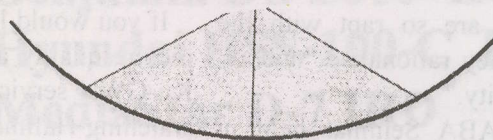
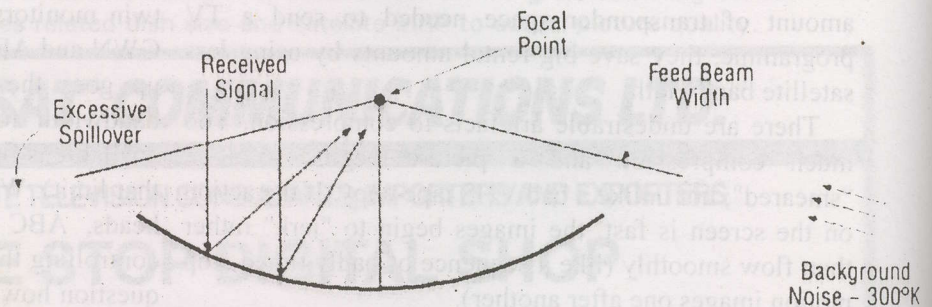

Don't leave dBs behind at the dish - get all of the signal your system is capable of producing!

Uncle Baysat recommends and uses for our own installations the versatile ADL range of feeds - there is **ONE** correct feed for every dish installation - ADL makes it and Uncle Baysat has it in stock!

**AND -**

**REMEMBER BaySat is your ONE STOP shop for all Satellite/MATV/SMATV and CATV requirements!**

**BAY SATELLITE TV LTD**

**YES!**

We STILL accept  
VISA, Mastercard with  
no surcharge!

PO BOX 3311 • Napier • New Zealand • Tel toll free 0800-BAYSAT  
International 64-6-843-5296 • Fax 64-6-843-6429 (0800-229-728)  
Physical location • 19B Carnegie Road, Onekawa, Napier  
<http://www.baysat.co.nz>  
e-mail [john@baysat.co.nz](mailto:john@baysat.co.nz)



**THE NEXT BEST  
THING TO BEING  
HARD WIRED  
TO THE BIRD...**



**... The Palcom SL-7900RP  
first choice of satellite  
experts, performance  
conscious installers and  
quality driven consumers  
across the Pacific and Asia.**

SL-7900RP: 500 channel memory Hi-Fi Stereo satellite receiver with full motorised actuator dish control built-in. Two IF inputs (950-2050 MHz); Standard 27/18 MHz IF bandwidths, plus 32 step threshold extension for signals as weak as 3dB C/N; Fully tuneable audio sub-carrier range (5.5 - 9.5 MHz) independent on L and R channels; Selectable wide (280kHz) and narrow (150kHz) audio bandwidth with J17, 50uS or Hi-Fi 1600 de-emphasis; Full polarizer control; TV modulator (E21-E69) + 3 SCART 21 pin outputs, separate L and R RCA audio outputs. Every function (including antenna, feed settings) logged into memory for instant recall - totally automatic channel search with companion handheld IR remote. Consistently rated by leading publications "Most versatile, low threshold, ultimate consumer receiver" world-wide. Truly, the next best thing to being hard wired to the satellite.

SL-7900RP from Bay Satellite TV Ltd, P.O. Box 3311, Napier, NZ. Tel 64-6-843-5296 (Fax 64-6-843-6429)

*with software by....*

**PALCOM**

State of the Art Simplicity

One Year Ago This Receiver Would Have been An Impossible Dream-

## The D7 MediaStar from OPAC Pty Ltd

If you are a consumer, or you are a TVRO dealer who is looking for a hassle-free digital receiver, the D7 MediaStar created for OPAC Pty Ltd could be your answer. This is not the perfect receiver if you are a die-hard in the wool satellite "enthusiast" who likes to spend idle hours cruising from satellite to satellite, polarisation to polarisation searching for new, unlisted digital feeds.

Let's look at the major problems to date with free to air (FTA) digital IRDs:

1) *Being slow and slower.* You manually load into an IRD the magic numbers (frequency, Msym, FEC) for a new service you have learned about, push the appropriate (OK) button on the remote and the receiver takes off to locate the new service. With some receivers, the "search" may take "several minutes time" (at least that is what the on screen display warns while the search is underway). You could probably go to the frig, get a beer, and return the empty bottle while it is searching.

We found the D7 will load a new service in 15 seconds time or less; every time, whether SCPC or MCPC.

2) *Being unpredictable.* You want to change programme channels and your receiver gives you nothing but a series of programme channel numbers. If you select the number that corresponds to the service you wish to view, you may wait several minutes while the receiver relocates the previously loaded service (another trip to the frig and a beer). It may not find it at all and flash an ominous message about your cable being bad or a connection being loose.

The D7 provides an on screen menu; select what you want from the list and in a second or less time it is there. Beer consumption will go down in a D7 equipped household.

3) *Being unsure* why a service you have selected is not showing on the screen. You recently watched Sky News London on AsiaSat 2 and it is loaded in your receiver. Now when you go to it, the screen is blank (in the meantime you have been to the frig for another beer). Did the receiver screw up? Is the service off the air? Do you have a loose cable someplace? Frustration.

The D7 immediately tells you the service is now encrypted on a status bar across the top of the screen.

The D7 runs cool (without a fan) although users are wisely advised in the manual not to stack it with other electronic equipment (a "heat sandwich" is never a good idea with electronic units). Software to operate the

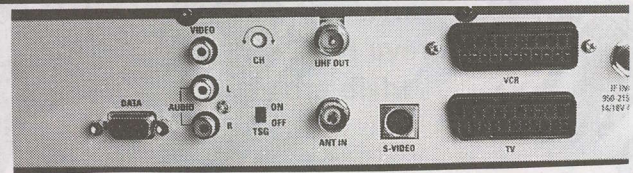
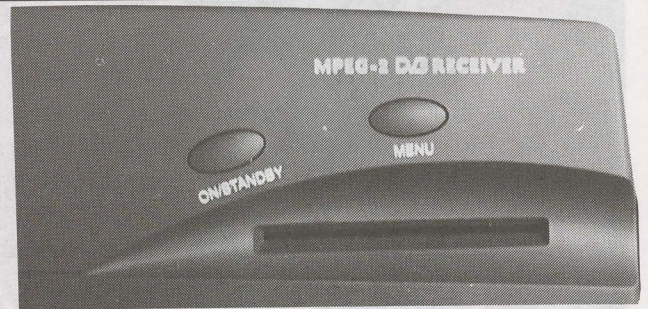

receiver is put in at the factory but updated with the latest programmer listings by the distributor (Opac). The programmers are arranged, on purpose, by satellite and the software has been set-up to accommodate 8 different satellites (PAS-2 C and PAS-2 Ku are *two*, not one satellite in memory). When the receiver comes out of the box in your hands, it will have all of the known programmers preloaded by Opac. Installation consists of unpacking, connecting up the power, L-band and output cables, and tuning in the output on a video monitor or UHF tuned TV receiver.

The user or installer can add new programmers manually. You enter the set-up menu with a password (default is 0 0 0 0) and then select "Manual Search." The screen is split in two with the

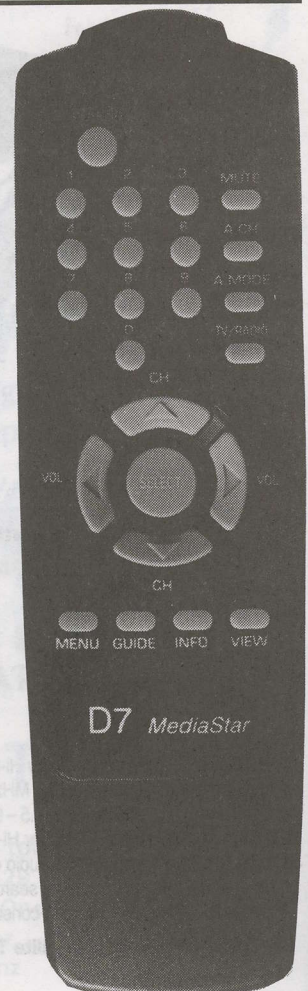

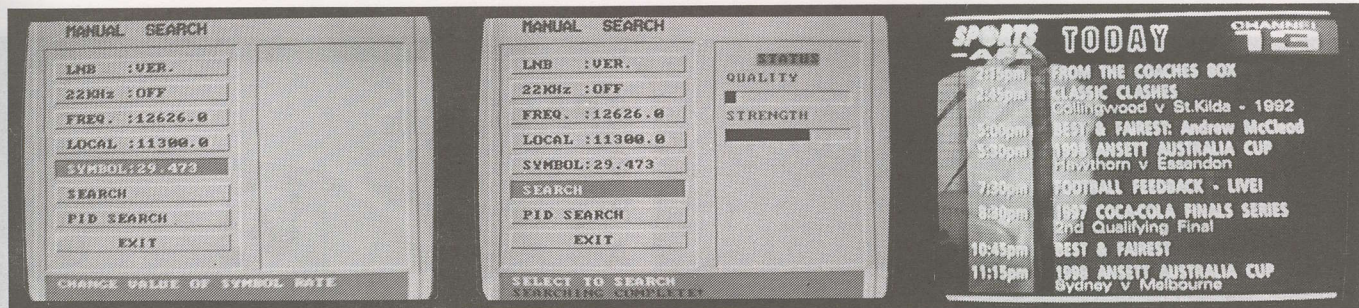

As each parameter in a new search is entered, the relevant numbers appear on right hand side of screen in a box. Once entered, search is selected (left) and within 15 seconds the bouquet is loaded (centre). After loading, you can "exit" / "exit" or go directly to pictures by pushing View on the remote (right).

fixed menu parameters on the left, the new numbers you are entering appear and disappear on your command on the right hand side. The C-band frequency is entered, the local oscillator frequency (5150 for C-band, 11,300 or as appropriate for your LNB/F at Ku), and the symbol rate (Msym). All of these numbers appear monthly in the Digital Watch Tables of SatFACTS. The receiver will search on its own for the proper FEC number, so you select "Search" and within 15 seconds (often far less) the new service is loaded.

The software determines the range of the "Auto Search" mode; the D7 will not (as with some Nokia versions) search through a satellite and load every digital signal it finds. "Auto" means it will move at your command to a new satellite and then search through the channels preloaded there. New channels that you find and load after the original receiver programming can be "edited" to appear in the proper satellite "file."

In the signal status mode, the right hand screen tells you the signal quality (a series of bars) and strength (another series of bars). We found the strength bar was generous (even on weak signals) and the quality bar had to have at least one block lit up or you were not going to watch that channel. A weak channel (such as EMTV) still registered on the strength bar set quite generously although the quality bar was absent any indication. In cases where the programmer is playing games with the PID numbers, a PID search menu allows you to directly enter the three relevant PID numbers.

Yes, the D7 does NTSC and NTSC PowerVu (FTA only of course). We found in testing on some NTSC services (such as Star Japan, before they went CA) the audio lip sync was "off" with slightly delayed audio. However, problems other receivers exhibit with NTSC and PowerVu were not present and yes, you could leave the receiver on services such as BBC World (PAS-2, PowerVu NTSC) and not lose the audio after an hour or two (as some other receivers do). The normal NTSC 3.58 (colour subcarrier) is outputted at 4.43 / 60 hertz to improve the compatibility of the receiver with domestic PAL receivers. If you prefer the 3.58 version output, Opac says they can oblige with a software change before shipping. Anyone who has handled virtually any brand of IRD will find the D7 easy to use with a minimum of learning curve time.

Negatives? Sensitivity. Our benchmark receiver is a software version 5.0 Nokia e3: all receivers are compared to this unit. On a marginal C-band SCPC and a Ku-band MCPC, we found the D7 is 0.7 to 0.9 dB less front end sensitive than our benchmark.

Input Frequency Range	950 - 2150 MHz
Required Satellite Levels	-30 dBm to -65 dBm
Receiver IF bandwidth	36 MHz
FEC Range	1/2 through 7/8
Symbol Rate	2 to 45 Mbps
AFC Range (1)	+/- 3 MHz
22 kHz Switching Tone	Option
DC Voltage to LNB	13 or 18V at 400 mA max
Audio Connectors	RCA /left and right channels
Video connectors	RCA + 2 SCART, S-VHS
TV Standards (2)	PAL and NTSC
Decompression standard	MPEG-2 & MPEG-1 compatible
Modulator Output Frequency	543.25 to 663.25 MHz
Modulator output level	+10 dBmV (70 dBuV)
Modulator Audio Subcarrier	5.5 MHz
Mains operating voltage	100 - 240VAC, 50/60 hertz
Current software version	2(.050)
Suggested Retail Price	A\$995
Master Distributor	Opac Pty Ltd (tel 61-2-9584 1452)

- 1/ This is difficult to measure between SCPC and MCPC services but is certainly state of the art
- 2/ The NTSC processing is not perfect (see text) although it may not be objectionable to most users

Load time manual - new service	typically less than 15 seconds
Sensitivity compared to Nokia e3	0.7 to 0.9 dB below Nokia
Ease of use	Superior to anything reviewed to date

a technical and marketing  
 advisory  
**memo**  
 to the membership from your  
 industry trade association

## SPACE Pacific

Satellite  
 Programme  
 Access  
 CommittEe



A trade association for users, designers,  
 installers, sellers of private satellite-direct  
 systems in the Pacific Ocean & Asia Regions

### Two From One

One of the early, popular styles of satellite dish antenna was a spherical design. A spherical is a section of a parabola, greatly expanded in size so that rather than being truly parabolic in shape it is a conical segment of a parabola. The offset fed, Ku band dishes installed for Galaxy and Sky TV (NZ) are a form of spherical antenna. One of the advantages of any

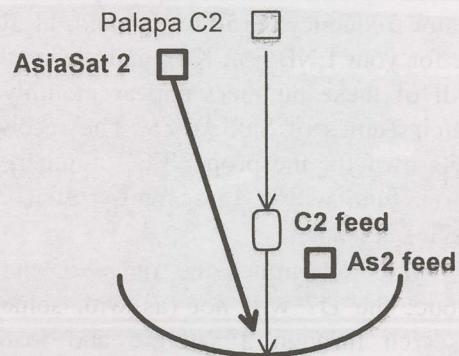

spherical is the ability to position separate feeds (plus LNBFs) along a line in front of the dish to allow reception from multiple satellites at different locations. By having one reflector surface, and two or more LNBFs each positioned at the focus point from the reflector for one satellite, you can switch between satellites using a multi switch to select the appropriate RG6 down line cable going to each LNBF.

Roger Woodward (Sydney, NSW; email [RWOODWARD@NNPBIPSI.TELSTRA.COM.AU](mailto:RWOODWARD@NNPBIPSI.TELSTRA.COM.AU)) shows us how he has made a 3m normal parabolic function simultaneously on Palapa C2 (113E) and AsiaSat 2 (100.5E) by offsetting the second C-band feed for AsiaSat 2 while the dish is pointed at C2. Yes, there is a bit of trial, signal search and error in this but it allows two relatively close spaced C-band birds to be

## MEMBERSHIP IN SPACE

Membership in SPACE Pacific is open to any individual or firm involved in the "satellite-direct" world in the Pacific and Asia regions. There are four levels of membership covering "Individuals," the "Installer/Dealer," the "Cable/SMATV Operator," and the "Importer/Distributor/Programmer."

All levels receive periodic programme and equipment access updates from SPACE, significant discounts on goods and services from many member firms, and major discounts while attending the annual SPRCS (industry trade show) each January in Auckland. Members also participate in policy creation forums, have correspondence training courses available. To find out more, contact (fax) 64-9-406-1083 or use information request card, page 34, this issue of SatFACTS. Page space within SatFACTS is donated each month to the trade association without cost by the publisher.



received simultaneously without an actuator on the dish. Normally, select the weaker satellite for prime focus and the stronger for secondary feed focus (the offset feed). Some experimentation will be required to locate the

secondary focal point which can be mounted with aluminium strips and saddle clamps once it has been found. Typically, a 3m dish will allow simultaneous reception for satellites up to 15 degrees apart on the arc.

**Distribution centre of DVB MPEG-2 digital receivers for FREE-TO-AIR satellite TV programmes.**

**Wholesale & Retail Welcome**

Consumer grade ---

**HYUNDAI (HSS-100C),  
NOKIA (DVB 9500S),  
PACE (DSR 200)**

Professional grade ---

**DMV (System 3000),  
Hirschmann (DVB7500)  
Philips (DVS 3950/11)**

Satellite IF distribution equipment --  
**GLOBAL.**

Come and visit us if you pass by Hong Kong!

Hong Kong Satellite TV  
Ltd., Unit C, 7/F, Block  
6, Tien Chu Centre, 74  
Pak Tai St, Tokwawan,  
Kowloon, HONG KONG  
tel: (852)2736-8703  
fax: (852)2735-0583  
email:  
hkstvt@netvigator.com

✓ YES, please send me info  
about \_\_\_\_\_ brand  
Company \_\_\_\_\_

Detail address: \_\_\_\_\_

\_\_\_\_\_ p'code \_\_\_\_\_

Tel: \_\_\_\_\_

Fax: \_\_\_\_\_

**SCITEQ**  
PTY LTD ACN 009 235 090

**Trade supplier of:**

- Nokia Receivers
- Orbitron Dishes
- ADL Feedhorns
- Gardiner LNB's
- other satellite accessories

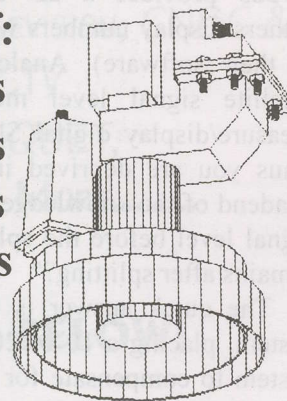

**Phone: +61 8 9306-3738**

**Fax: +61 8 9306-3737**

sales@sciteq.com.au

http://www.sciteq.com.au

33 Kentia Loop, Wanneroo  
WESTERN AUSTRALIA 6065

# The CABLE Connection

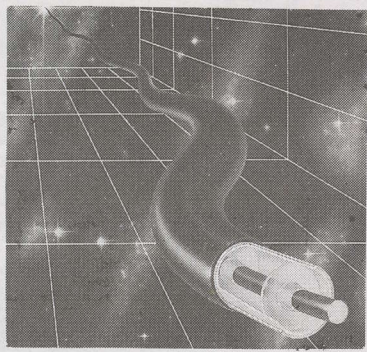

As bouquet operators cram more and more services into MCPC digital packages, and as the quantity of SCPC services increases month to month, sooner or later a cable or SMATV headend is faced with re-amplification of the L band signals fed from the antenna. The common practice calls for installing a two-way splitter when two receivers are fed from a single polarity feed line, a four way splitter when 3 or 4 receivers are connected, and then some combination of two and four way splitters when the receiver totals go beyond 4 per polarity.

A two-way splitter lowers the original end of line L-band signal by 3.5 (4 is a safer computation number) dB; a four-way by 7.5 (again, 8) dB. A combination of a two-way followed by a four-way reduces the signal at the output of the four way(s) by no less than 11 (12) dB.

A signal level in the region of -50 dBm is not uncommon at the end of 30 metres of RG6 cable fed to the equipment from an outdoor antenna + LNB(F). A 12 dB reduction in the before-split level would result in each receiver at the end of a 2 + 4 way split chain receiving marginally more than the minimum recommended input level.

Of the digital IRDs commonly available, only the SA D9223 provides a dB calibrated on screen display (others display numbers which are at best scales unique to their software). Analogue spectrum analysers and satellite signal level meters cannot be utilised to measure/display digital SCPC or MCPC signal levels. Thus you are deprived in laying out a multiple IRD headend of the knowledge you badly need; "What is the signal level before the splitting begins, and, how much remains after splitting?"

The quick answer is to "throw some gain" at the system, placing a 10 or 20 dB "line amplifier" into the system to compensate for split (and cable) losses. Line amplifiers are both a curse and a blessing. The amplifier in front of the line amp is the LNB(F) and the system noise figure (threshold) created by the LNB(F) sets the standard of performance for the line amp. Unfortunately, a line amp can only degrade the ratio between the system noise and the system carriers (signals). If you are capable of measuring the BER (bit error rate) of a digital signal before and after the line amplifier is added to the

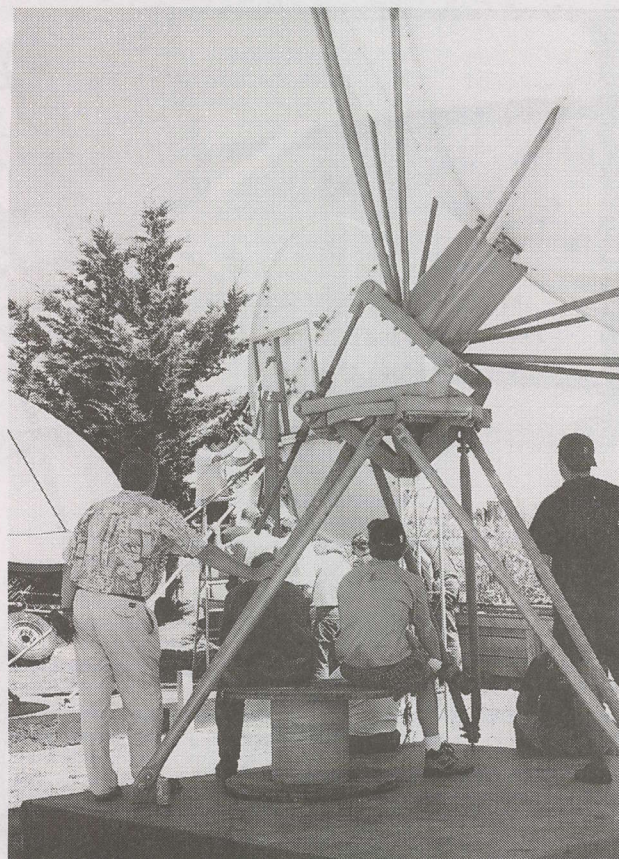

Background - SPRSCS '98 attendees play in the real world, attempting to improve AsiaSat 2 reception using 3.7M dish on weaker side vertical polarity. Foreground, staying out of the sun under 4.6m "umbrella."

system, do so as a guide to what the line amp actually does to system performance. The intended purpose is to increase the digital signal *voltage* level to compensate for split or cable losses. If the BER is actually better with the amp than without it, this tells you one of two things: The signal level to the receiver before the line amp was added was on the ragged edge of being below receiver threshold, or, more likely, there is something not right with your splitter network. The line amp should be installed just ahead of the first splitter, and then only when you actually need a line amp (often you do not).

Commercial grade line amps such as the California Amp model here are significantly higher quality and better performing than consumer grade devices but at a price that is around 6 times consumer unit pricing. Rule of thumb: Use a line amp only when absolutely necessary and then use one suited to the job at hand.



HIGH tech (left), low tech (right) line amps

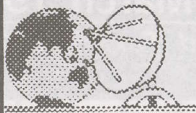

# NATIONWIDE ANTENNA SYSTEMS

## & SPECIALTY PRODUCTS PTY LTD

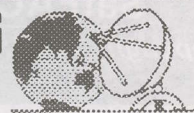

# PRODUCT RELEASE

## YURI YDR-100 DIGITAL SATELLITE RECEIVER

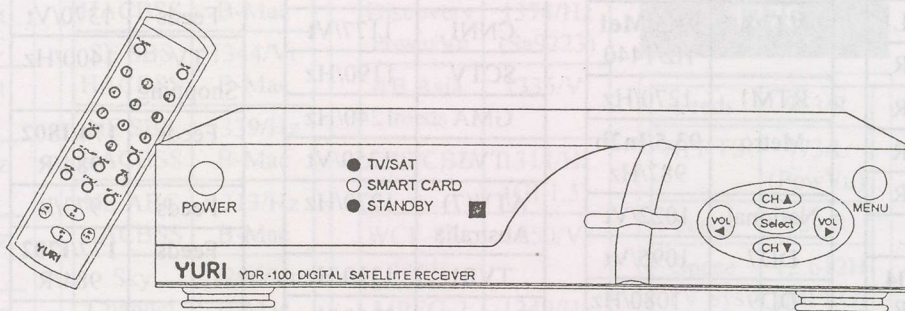

## LOOKS FAMILIAR ?

THIS RE-BADGED HYUNDAI HAS The Latest 2.27 SOFTWARE THAT ACTUALLY IMPROVES THE RECEIVERS CAPABILITIES

➡ No LIPSYNC PROBLEMS

➡ No LOCKUP PROBLEMS

**You Can Now Watch:** BBC WORLD, COUNTRY MUSIC TELEVISION, CNBC & NBC, EWTN, BLOOMBERG, CCTV BOUQUETS, EUROPEAN BOUQUET, THE HALLMARK CHANNEL & MUCH MORE.....

**FOR OUR SPECIAL PRICE -  
CALL THE ORDER HOTLINE NUMBER BELOW!**

EMAIL 

experts@mailbox.uq.edu.au

**Order Hotline  617 3252 2947**

# SatFACTS Pacific/Asian Region Orbit Watch: 15 March 1998

Copyright 1998: SatFACTS, PO Box 330, Mangonui, Far North, New Zealand (Fax: 64-9-406-1083)

## Analogue Free-to-Air 57E to 80E

Tests	<b>55E/2DT</b> 1119/L
DDI tests	995/L
Sun Music	<b>57E/703</b> 1395/R
RTNC	1352/R
Tests	1305/L
Gemini	1220/R
AsiaNet	1170/R
WorldNet	1095/R
TVi	1025/R
Muslim	975/L
Tests	<b>66E/704</b> 1385/R
Feeds (SE beam)	1305/R
Home TV	<b>68.8/Pas4</b> Vt/1310
ABN	Hz/1365
Sony TV (Hindi)	Hz/1240
Doordar.	Vt/1116
CNNI	Hz/1065
TNT/Cart.	Hz/1040
MTV Asia	Hz/965
ZJTV	<b>76/Ap2R</b> 1390/Vt
TVB tests	990/Vt
TVT	<b>78.5/Th3</b> 1280/Vt
Army TV	1390/Vt
ViJay TV	1480/Hz
RAJ-TV	1510/Vt
Sony TV	1630/Hz
TK Rossija	<b>80/Exprs.</b> 1475/R
Feeds	1315/R
VTV4+	1275/R
ACT/TB3	1225/R
TV Center	1025/R

## Anal. Free-to-Air 80E to 113E

Russia 3	<b>80/Exprs</b> 1025/R
RTR I	<b>90/S6</b> 1475/R
Orbita I	1275/R
RTR II	1234/R
Orbita II	1215/R
VTV4	<b>91.5/Me1</b> Hz/1440
RTM1	1270/Hz
Metro	<b>93.5/In2b</b> 987/Hz
National	1022/Vt
DD7	1095/Vt
DD9	1080/Hz
DD.7 (T)	1070/Vt
DD.9(K)	1180/Vt
DD.5(T)	1256/Vt
DD.1	1268/Vt
DD.	1310/Vt
DDMMBI	1338/Vt
DD.4	1388/Vt
ORT 1	<b>96.5/S14</b> 1475/R
Madagascar	1325/R
Tv Azer.	1275/R
ERTU Egypt	<b>100.4/As2</b> 1508/Hz
TV Shopping	1490/Vt
Mongolia, Iran/plus	1470/Hz
Star News	1410/Vt
Feeds	1290/Vt
WorldNet	1265/Hz
CCTV4	1190/Hz
RTPi	1170/Vt
RTR	<b>103/S21</b> 1475/R
Vrk/Apt	1275/R
TPI	<b>113/C2</b> 967Vt
CFI/TV5	990/Hz

## Anal. Free-to-Air 113E to 148E

Brunei, feeds	<b>113/C2</b> 1010/Vt
MTV Asia	1030/Hz
TV Indosiar	1090/Vt
ABN	1110/Hz
ANteve	1130/Vt
CNNI	1177/Vt
SCTV	1190/Hz
GMA	1240/Hz
TV3	1250/Vt
ATV(7) Australia	1270/Hz
TVRI	1310/Hz
Gujarat +	1350/Hz
RCTI	1408/Vt
CNBC	1530/Hz
Test Card	<b>128/Jc3</b> 1070Vt
CETV SD	<b>134/Ap1A</b> 1330/Hz
CETV2	1250/Vt
CETV1	1170/Vt
CNNI	<b>138/Ap1</b> 1170/Vt
CCTV7	990/Hz
Orbita-I	<b>140/S7</b> 1475/R
NTV	1425/R
ORT1	<b>145/S16</b> 1475/R
RTR Russia	1275/R
Test Card	<b>148/Me2</b> 1070/Hz

Worldstar Radio Sat  
Asiastar 1 to 105E  
(12/98); downlink  
1.451-1.492 (GHz).  
Audio channel capacity:  
576 @ 16Kbit/s.

Polarisation?  
/L is left hand circular, /R is right hand circular, /Vt is linear vertical, /Hz is linear horizontal.

## An. Free-to-Air 150E to 180E

RCTI	<b>150/C1</b> 990/Hz
CNNI	<b>169/Pas2</b> 1183/Hz
CNN Feeds	1155/Hz
NHK	1114/Hz
Feeds	1370/Vt
TV Shopping	1400/Hz
Feeds	<b>174/1802</b> 984/R
Feeds	973/R
Feeds	<b>177/1702</b> 984/R
Feeds	963/R
Feeds	<b>180/1701</b> 1430/R
Feeds	1340/R
Feeds	1175/R
RFO	1105/R
Feeds	1020/L

## PALAPA C1 150.5E

Tests	990Hz
Tests	1030Hz
Tests	1140Hz
Tests	1220Hz
Tests	1330Hz
Tests	1360Hz

## Encrypted Analogue

Discov. India	<b>68.8/Pas4</b> 1365/Vt
ESPN	1290/Hz
HBO Asia (d) *	<b>113/C2</b> 1150/Hz
Discovery (d) *	1430/Hz

\* scheduled to close by March 30, 1998

## NON MPEG-2 DIGITAL SERVICES

People's Net (GI 1.5)	<b>113/C2</b> 1220/Hz
RPN-9 (SA 1.5)	<b>142/G2</b> 1225/L
Fox/Prime (SA 1.5)	<b>169/Pas2/</b> 1161/Vt
Filipino Channel (GI 1.5)	1314/Hz

(a) B-MAC encrypted, no access available; (c) MPEG encrypted, access may be possible; (d) B-MAC, access for DTH possible some geographic areas.

## MARCH ALERT

AsiaSat G (122E), 3675 LHC which may be testing digital at this time. NHK transition to digital (PAS-2, 4035/1115 Hz) will see existing analogue moving to unknown Vt PAS-2 until 1 July. NZ, especially South Island should check for possible service on 177Ku, 12.612Hz (26.694, 3/4) with FTA programme channel 301. WA note: Intelsat 801 (64E) is no longer - moved to 27.5W. Expansion of Galaxy programming using 12.689Hz (B3) possible.



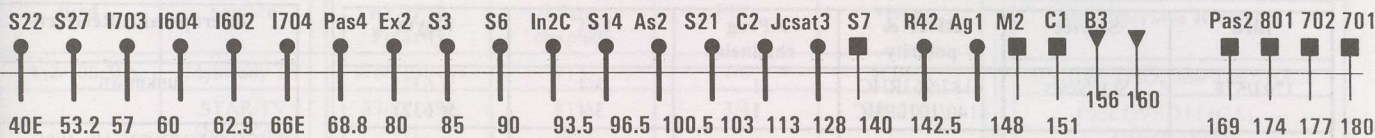

**OPTUS B3  
156E  
(Ku only)**

ABC WA	1358/Vt B-MAC
Imparja	1355/Vt B-MAC
GWN (Temp OFF)	1300/Vt B-MAC
Net 9, Sky	1233/Vt B-Mac
Austar test Mpeg2	1389/Hz
Optus test Mpeg2	1326/Hz
Optus Mpeg test	1264/Hz
Imparja N.T.	1214/Hz B-MAC
Aurora Mpeg test	1169/Vt
Galaxy	1137/Hz Irdeto Mpeg 2
Galaxy	1073/Hz Irdeto Mpeg 2

**Optus A3/152E(a)**

ATN7png	1297/Vt
ATN7png	1430/Vt

a/occasional use

**Palapa C2 Ku  
(seen South  
equator)/113E**

Test bars	11.148/Vt
-----------	-----------

**MeaSat 2  
148E**

Tests	1070/Hz*
-------	----------

\* Colour bars , audio 6.8;  
C-band covers Aust, NZ

**OPTUS B1  
160E  
(Ku only)**

Data	1402/Hz
QSTV	1377/Hz B-Mac
SE ABC HACBSS	1370/Vt B-Mac
SE SBS HACBSS	1344/Vt B-Mac
NE SBS HACBSS	1339/Hz B-Mac
NE ABC HACBSS	1313/Hz B-Mac
Sky Channel	1296/Vt B-Mac
ABC Radio	1276/Hz (digital)
OmniCast	1270/Vt (FM/FM)
ABC feeds	1247/Hz Pal
Sky Nz (sport)	1245/Vt VidCrypt
Net 9 feeds	1220/Hz B-MAC
Sky Nz (Orange)	1218/Vt VidCrypt
Net 10	1182/Vt E-Pal
Net 9	1180/Hz E-Pal
Net 10 feeds	1155/Vt Pal
QTQ9	1145/Vt
Net 7	1120/Vt E-Pal
Net 9 feeds	1091/Vt Pal
Aurora MPEG-2	1076/Hz (tests)
CAA air to ground	1009/Vt Nbfm

**PAS-2  
169E  
(C + Ku)**

CCTV	1433.5/Vt (Sa9223)
Napa feed	1407/Hz
Value Ch.	1400/Vt
Discovery PowerVu	1374/Hz (Sa9223)
AB Asia, feeds	1335/Vt
ABS/CBN	1314/Hz (GI 1.5)
WCE-TV, feeds	1250/Vt
MPEG-2 PowerVu	1249/Hz (Sa9223)
CNN+ (1/2Tr)	1183/Hz
FoxSports	1160/Vt (SA 1.5)
Feeds	1150/Hz
NHK (April 1 PwrVu)	1115/Hz
Feeds	1105/Vt
Napa feed	1065/Vt
NBC Mux MPEG	1057Vt (Philips)
MPEG-2 PowerVu HonKong	1002/Vt
TCS Sing.	967/Hz

**PAS-2 Ku**

GWN	12.263V
MediNet	12.286V
Telstra Bendigo	12.300V
Napa TC	12.415V
MTV Asia	12.604V (MPEG)
ABC Interchge	12.629, 638, 646 /Vt
Herblife	12.732H

**Intelsat 801  
174E**

Feeds	963/R
Feeds	984/R

**Intelsat 702  
177E**

Feeds	963/R
AFRTS	973/L (PowVu)
Feeds	984/R
Space TV Sys	12.612H (MPEG)

**Intelsat 513  
177W**

Feeds	963/R
Feeds	984/R

**(513 Ku)**

Service	RF Freq.
US Nets	10.980V
NBC	11.015V
Feeds	10.510V

**Ku Services**  
Intelsat Ku band services shown here are boresighted to Japan and nearby Asia, have not been reported south of equator.

**TDRS5 / 174.3W**

Fuji TV	1305/Hz
BBC World	1163/Hz MPEG

**Intelsat 701  
180E(W)**

TVNZ	955/Dmv 3000
TVNZ	964/Dmv
TVNZ	972/Dmv
TVNZ	980/Dmv
TVNZ	988/Dmv
Occ Vid.	1,020**
TVNZ	1,030
SPN	1,069
RFO Tahiti	1,105
SCPC	1,126
SCPC	1,136
Vidip/(e)	1,220
Feeds	1,254
NHK(e), NBC	1,270
TVNZ	1,293/e
Feeds	1,340
10 Oz MCPC	1,385 (PwRvu)
CNN USA(e)	1430

\* RHC & LHC  
\*\* LHC only  
e/ encryption

**(701 Ku)**

NHK	11.135H
CBS	11.475H
CNN	11.508H

**UPCOMING SATELLITE LAUNCHES**

ChinaSat 1 to 87.5E (?) now April  
Gorizont 33 (last of series) to unknown  
destination - now "March"  
PAS-7 delayed to 4th quarter (68.8E)

# SatFACTS Pacific/Asian MPEG-2 Digital Watch: 15 March 1998

Bird	Service	RF/IF & polarity	# Prog channels	FEC	Msym
I703/57E	Sky News	4187/963RHC	1	3/4	5(.632)
		4140/1010RHC	1	3/4	5(.632)
I704/66E	CFI	4055/1095RHC	4	3/4	27(.500)
	Indian bouquet	4068/1082LHC	2(?)	1/2	7(.100)
PAS4/68.5E	ART/RAI, BBC	3966/1184Vt	2	3/4	5(.632)
	TVSN +	3743/1407Hz	6	3/4	21(.800)
	CCTV	3716/1434 Hz	6	3/4	19(.850)
Ap2/76E	AXN	3920/1230Hz	8	7/8	28(.340)
Thaicm 3/78.5E	UTV	3920/1230Hz	6TV(#1)	3/4	27(.500)
	UTV/MCOT	3880/1270Hz	8TV(#2)	3/4	27(.500)
	Reuters Feeds	3636/1514Hz	1TV	3/4	5(.632)
	Unknown	3600/1550Hz	8TV	3/4	26(.662)
Measat 1/91.5	India Bouquet	12284/12346Vt	10+TV?	7/8	30(.000)
As2/100.5E	Chinese tests	12.295Hz	1TV	2/3	6(.103)
		12.329Hz	1TV (BTv 1)	1/2	6(.930)
As2/100.5E	Laos TV	4143/1007Hz	1TV	2/3	2(.889)
	Euro. Bouquet	4000/1150Hz	6TV, 1r. (#3)	3/4	28(.125)
	Hubei TV (HBTv Main)	3854/1296 Hz	2	3/4	4(.418)
	Hunan TV (SRTC)	3847/1303 Hz	1	3/4	4(.418)
	Guandong TV (GDTV)	3840/1310 Hz	1	3/4	4(.418)
	Inner Mongolia TV Zizhiqu	3828/1322 Hz	2	3/4	8(.397) (1-China) (2-Mongolia)
	APTV London	3800/1350 Hz	1	3/4	5(.631)
	BBC Radio	3793/1357 Hz	?	?	?
	WTN Jerusalem/London	3790/1360 Hz	1	3/4	5(.631)
	WTN London	3786/1364Hz	1	3/4	5(.631)
	WTN HK	3775/1375 Hz	1	3/4	5(.631)
	Liaoning TV (Service 2)	3734/1416 Hz	1	3/4	4(.418)
	Jiangxi TV (JX Sat TV)	3727/1423 Hz	1	3/4	4(.418)
	Fujian TV (SETV)	3720/1430 Hz	1	3/4	4(.418)
	Quinghai TV Zenghou	3713/1437 Hz	1	3/4	4(.418)
	Henan TV Main	3706/1444 Hz	1	3/4	4(.418)
As2/100.5E	Sky Racing	4020/1135Vt	3TV	1/2	18(.000)
	EMTV	4006/1144Vt	1TV, 2 radio	3/4	5(.632)
	Hallmark/KIBC	3940/1210Vt	2TV	2/3	26(.655)
	STAR TV	3900/1250Vt	5TV (#4)	3/4	28(.100)
	Hei Long Jiang	3834/1316Vt	1TV	3/4	4(.418)
	JSTV	3827/1323Vt	1TV	3/4	4(.418)
	AHTV	3820/1330Vt	1TV	3/4	4(.418)
	"QQQ" China (Shaanxi)	3813/1337 Vt	1, 1 Radio	3/4	4(.418)
	Guangxi GXTV	3806/1345Vt	1, 1 Radio	3/4	4(.418)
	Eastern TV Taiwan	3785/1365 Vt	5TV (#5)	3/4	18(.000)

Interoperable Receivers
unknown
N163/17X/2X. HS-100C
HS-100C. e3
e3
(MPEG-2, Iredeto) (CA)
Pv9223, N163/2X. HS-100C
Nokia e3. probably others
Mostly CA
Mostly CA
Nokia e3. probably others
Nokia e3. probably others
Philips
HS100C. e3
HS-100C. N163. e3
ANY DVB receiver
HS-100C. N163/17X/2X. N2000. Ph3950/11
HS-100C. N163/17X/2X. N2000. Ph3950/11
HS-100C. N163/17X/2X. N2000. Ph3950/11
HS-100C. N163/17X/2X. N2000. Ph3950/11
DMV, HS-100C. N163 /17X/2X
(Comstream ABR200/202)
DMV, HS-100C. N163/17X/ 2X
Mostly CA now
DMV, HS-100C. N163/173/2X
HS-100C. N163/17X/2X. N2000. Ph3950/11
HS-100C. N163/N17X/2X. N2000. Ph3950/11
HS-100C. N163/17X/2X. N2000. Ph3950/11
HS-100C. N163/17X/2X. N2000. Ph3950/11
HS-100C. N163/17X/2X. N2000. Ph3950/11
Pace DVS-211 (CA)
HS-100C. N163. Pv9234
HS-100C (2.05). e3 (V5.0)
Now all CA (Pace DVS211)
HS-100C. e3
HS-100C. e3
HS-100C. e3
HS-100C. N163/17X/2X. N2000. Ph3950/11
HS-100C. N163/17X/2X. N2000.
Pv9223 (CA)

Bird	Service	RF/IF & Polarity	# Prog. channels	FEC	Msym
(As2/100.5E)	Myawady TV	3766/1384Vt	1TV	7/8	5(.080)
	STAR TV Hong Kong	3700/1450 Vt	8TV (#6)	3/4	28(.100)
C2/113E	Tests	11.500Hz	multiple TV	7/8	26(850)
	Star Indovision	3500/1650Hz 3580/1570Hz	20 TV (#7)	7/8	26(.850)
	Indovision	3460/1690Hz	6TV	7/8	21(000)
	MegaTV	3780/1370Vt	5TV (#8)	3/4	27(.500)
Thaicom 1/120E	Thailand terres.	4120/1030Vt	6TV	2/3	27(.500)
APIA/134E	AXN	4060/1090Vt	8	7/8	28(.340)
API/138E	Reuters	3732/1418Vt	1TV, data	3/4	5(.632)
Palapa C1/150.5	Indovision	4117/1033Hz	10TV	7/8	26(.850)
Optus B3 156E	Galaxy	12.438Hz 12.373Hz	20+TV (#9)	3/4	29(.473)
	Aurora Test	12.469Vt	3+ TV	2/3	30(.000)
	Optus Vision	12.564 Hz 12.626 Hz	16TV, 8 (#9A)	3/4	29(.473)
	Austar/Galaxy	12.689Hz	tests-up to 10TV	3/4	29(.473)
Optus B1 160E	Aurora (MPEG test)	12.377Hz	5+ TV (#10)	2/3	30(.000) [27(.500)]
PAS-2 169E	ABC Interchange	12.646 (.638, .629)Vt	1 TV (each)	3/4	16(.200)
	Telstra Bendigo	12.300Vt	3TV, 2 radio	1/2	10(.138)
	Mediasat	12.286Vt	1TV	3/4	6(.610)
	GWN Perth	12.263Vt	2TV, radio	1/2	13(.404)
	MTV Asia	12.605Hz	8TV	1/2	22(.490)
	Hong Kong PowerVu	4148/1002 Vt	8TV (#12)	2/3	24(.430)
	NBC Hong Kong	4093/1057 Vt	7TV (#13)	3/4	29(.473)
	JET Singapore	3962/1188 Vt	2TV (1-Ntsc, 2-Pal)	1/2	13(.740)
	ESPN (USA)	3860/1290Vt	4TV, 2 control	7/8	26(.470)
	CCTV China PwrVu	3716.5/ 1433.5 Vt	5TV (#14)	3/4	19(.850)
	TCS Singapore	4183/967 Hz	2TV (#15)	1/2	6(.620)
	ITJ-Japan	4.174/976 Hz	1 TV	3/4	5(.632)
	AAR-ART/RAI Int	4153/997 Hz	3TV (#16)	3/4	5(.632)
	Feeds	4138/1012Hz	1TV	3/4	6(.620)
	PAS-2 feeds	3940/1210 Hz	2TV(NTSC)	2/3	6(.620)
	California PowerVu	3901/1249Hz	8TV (#17)	3/4	30(.800)
	Disney/Aust.	3804/1346Hz	1TV	5/6	21(.093)
	Discovery Singapore	3776/1374 Hz	7TV (#18)	3/4	21(.093)
	Satcom 1-6	3743/1407Hz	6TV	7/8	19(.465)
	Unknown test	3718/1432 Hz	3TV	2/3	6(.620)
1702/177E	AFRTS	4177/973 LHC	8TV, 12 radio & data (#19)	3/4	28(.000)
	SPACE TV Systems	12.612/1312 Hz	13TV, 11 radio (#20)	3/4	26(.694)

Interoperable Receivers
HS-100C (PIDs now 1062/1063)
Pace DVS-211 (CA). N163/17X/2X
Pace DVS-211 (CA)
Pace DVS-211 (CA)
Pace DVS-211 (FTA?)
N2X/DVS-211(CA)
unknown
unknown
N163/17X/2X
same as 3580 C2
Gng, P400, P500, Pn520, + Pn630, Sk888 (c)
e3, HS100C
(when testing is over, only IRDs with CAM)
e3, HS100C, P400, P500, PN630
N163/17X/2X, Pv9223, HS-100C
Pv9223, Hs100C, e3
Pv9223/9234, (CA)
Pv9223, HS100C, e3 (some CA)
Pv9223/9234, HS100C, e3 (CA)
Unknown- Asia beam only
Pv9223, HS-100C(*), N2X* (some FTA)
HS-100C, Gng, N163/17X/2X, P400 (b), P500, Pn520, Pn630, Sk888
Pv9223 (CA)
Pv9223 (CA)
Pv9223, HS-100C, N163/17X/2X (FTA)
Pv9223, HS-100C N17X/2X (FTA)
HS-100C
HS-100C, Pv9223, N17X/2X, (continues FTA)
HS-100C, e3
Pv9223, N2X, HS-100C
Pv9223, HS-100C (*) N17X/2X (*), (some FTA)
Pv9223 (CA)
Pv9223, HS100C, N2X (occasionally Ch. 2 FTA)
Pv9223(CA)
e3
Pv9223 (CA)
XTCCDTV200 (All but 1#301 now CA)

# SatFACTS MPEG-2 Digital Watch: 15 March 1998 ♦ Support Data

Bird	Service	RF/IF & polar.	# Prog. Chs	FEC	Msym
<b>1701/180E</b>	TVNZ Gennet (feeds)	4195/955RHC	1TV(CA)	3/4	5(.632)
		4186/964	(BBC Gennet)		
		4178/972	1TV(CA)		
		4170/980	(APTV/Tokyo+)		
	Americas(radio)	4175/975LHC	3+ radio (?)	2/3	3(.680)
	TVNZ CRY	4120/1030RHC	1TV	3/4	5(.632)
	Canal Plus (test)	4091/1059LHC	1TV (?)	3/4	34(.368)
	SPN Nauru	4081/1069RHC	1TV	3/4	4(.730)
	TVNZTL	3857/1293RHC	MTV Europe	3/4	5(.632)
	10 Australia	3765/1385RHC	6TV	7/8	29(.900))

Interoperable Receivers
DMV, HS100C, N17X, 2X, e3 (for non CA channels when active; not all channels active all of the time)
e3, (CA)
(see TVNZ above)
MPEG 1.5, CA
HS-100C, e3
HS100C, e3 (now CA)
Hs100C, e3, Pv9223 (4ch CA)

**Bouquets:** 1) Thailand UTV: (1) CNN, (2) TTV, (3) ESPN, (4) HBO, (5) Ch. 5, (6) itv; 2) Thailand UTV/MCOT: (1)MCOT, (2) UTV Sports (3) test, (4) TTV News, (5) test, (6) Live, (7) Channel B, (8) Discovery; 3) European Bouquet. (1) Deutsche Welle, (2) MCM, (3) RAI International, (4) RTVE, (5) TV5 Paris, (6) [when operating] Deutsche Welle special programme channel with MediaNet VBI included [lines 10-15, requires DMV M2/Pro/Txt board inserted in 3000 series receiver]; Radio (1) DW#1 (stereo), (2) DW#2 (stereo), (3) DW#3 (stereo), (4) YLE (left) & RCI (right), (5) SRI (l) & WRN (r), (6) REE, (7) DW#1 (stereo), (8) DW#2 (stereo), (9) DW#1 (stereo), (10) NN RA6, (11) NN RA8; 4) STAR TV Hong Kong. (Now all apparently CA) (1) Sky News London, (2) Sports Contribution, (3) Channel [V] International, (4) Star Movies Japan [NTSC], (5) Star Plus Japan [NTSC]; 5) Eastern TV Taiwan. (1) "U1" [movies], (2) "U2" [news], (3) "U3" [sport, cartoons, general entertainment], (4) "Rock TV", (5) Rock TV; 6) STAR TV Hong Kong. (1) Channel 6, (2) ESPN Contributor, (3) Racing Ch., (4) Star Movies SEA, (5) Star Chinese, (6) NBC, (7) CNBC, (8) Sky News, (9) VIVA Cinema; 7) Indovision. (1) HBO Asia, (2) STAR Movies SEA, (3) Film Indonesia, (4) MGM Gold, (5) ESPN Asia, (6) STAR Sport, (8) Channel 'V' International, (9) Channel 'V' Asia, (10) RCTI, (11) STAR +, (12) Discovery, (13) STAR Movies and NBC Asia, (14) Phoenix Chinese, (15) CNN, (16) BBC World, (17) CNBC, (18) Cartoon + TNT, (19) Preview 1, (20) Preview 2; 8) MegaTV (1) CNNI, (2) Discovery, (3) ESPN Asia, (4) HBO Asia, (5) Cartoon + TNT, [(6) MGM Gold, (7) Cinemax (6-7 may not be operating)]; 9) Galaxy. Presently 22 programme channels. 9A) Optus Vision tests, FTA (temporarily): (1) Sports A, (2) ESPN, (3) Mega, (4) CNN, (5) Odyssey, (6) NHK, (7) Movie III, (8) TVNS or Disney, (9) Horizon, (10) Movie II, (11) Ovation, (12) Movie I, (13) Sky News, (14) Cartoon Net, (15) TNT, (16) Sports AFL; ; 10) Aurora. (1) SBS NT, (2)SBS NE, (3)SBS, (4) Sky News, (5) ABC WA ;12) Hong Kong PowerVu. (1) CTN 1, (2) CTN II, (3) TVBI Hong Kong, other feeds [NTSC], (4) TNT/Cartoons [PAL], (5) Ad-hoc II [NTSC], (6) ABN, (7) CTN II, (8) CTN; 13) NBC Hong Kong. (1) CNBC, (2) CNBC Mandarin A, (3) NBC Asia, (4) colour bars, occasional feeds, (5) CNBC Mandarin B (6) NBC "2" Asia/Taiwan, (7) Colour bars, "future" use; 14) CCTV China. (1) CCTV4, (2) CCTV3 [(3) CCTV 9, (4) CCTV4, (5) CCTV5, (6) CCTV8, (7) CCTV tests]; 15) TCS Singapore. (1) TCS Test, (2) TCS Default [repeats channel 1]; 16) SCPC3. (1) ad-hoc use, (2) AAR/ART, (3) RAI International; 17) California PowerVu. (1) CMT(NTSC), (2) CBS feeds, others including CTV Canada (NTSC), (3) ATN Asia TV Network(NTSC), (4) EWTN (NTSC) global Catholic radio, ch. 2, (5) BBC World (NTSC), (6) Bloomberg Financial (NTSC), (7) Golf Channel (NTSC), (8) Chile(NTSC); 18) Discovery. (1) Disc. Aust/NZ, (2) Disc. default, (3) Disc. Japan, (4) Disc. SE Asia, (5) Disc. Taiwan, (6) Disc. Philippines, (7) Disc. China; 19) AFRTS. Up to 19 video, audio, data cxhannels; non accessible (PowerVu CA); this is a very dangerous (Bootloader) place for D9223 receivers to be! 20) SPACE Systems (177E, Ku) claims to be back on the air with 11 CA Taiwan TV programming sources, 11 radio channels plus North American sourced adult channels Erotica and Exxtasy (all CA), and, (FTA) Thai TV 5 International (loads as Ch 301). Acer Computer receivers are said to now be available along with one year subscription cards that will function through December 31, 1998.

## MPEG-2 DVB RECEIVERS: [Data here is believed accurate; we assume no responsibility for errors in this volatile area!]

**Benjamin DB-5000**. FTA, unknown operational characteristics. Telsat (64-6-356-2749)  
**DMV/NTL 3000**. Skandia Electronics Pty Ltd (tel 61-3-9819-2466)  
**Grundig (Gng) DTR1100** (badged Panasat 630, believed no longer in production). Av-Comm Pty Ltd (tel 61-2-9949-7417)  
**Hyundai-TV/Com**. Model HSS-100C is officially available from Skandia Electronics (tel 61-3-9819-2466), Bay Satellite TV Ltd (tel 64-6-843-5296). Current version of chips 2.26.  
**Hyundai HSS-100B/G**. New January 1998; software version 5.0, see HSS-100C sources.  
**Hyundai HSS-100 V. 2.26** (with TV/Com tuner). Revised model available SATECH (61-3-9553-3399) and Bay Sat (64-6-843-5296).  
**MediaStar D7**. Supplier preloaded software known channels, V. 2.050 from Opac Pty Ltd. (61-2-9584-1233), Telsat (64-6-356-2749)  
**Nokia 9500 S (V1.63)**. This version is no longer available although it has ability to identify Msym and FEC parameters of unknown carriers. (V1.7X) was a German language "d-Box" version originally imported by OPAC; it functioned with the same parameters as the V1.63. (V2.X; 2.233/e3, 2.034 and others perhaps not yet identified) are current (after mid-1997) software versions that allow virtually unlimited stacking of bouquets and programmers and for at least the 2.233 version also allows limited red menu correction of NTSC glitch (see SF#36, p. 6). e3 is current Asia-Pacific factory version. Factory supplied sources known include: AV-COMM Pty Ltd (Tel 61-2-9949-7417); SCITEQ (61-8-9306-3738); Telsat (64-6-356-2749). AV-COMM also has macro-command IR remote that expedites 'red menu' operations for e3 version 9500 S. (see SF#36, p. 32); plug-in module for auto red menu NTSC (SF#41, p. 19).  
**Nokia "d-box" (V1.7X)** suitable for C-band use. Instructions, on-screen prompts may be in German. Be careful when buying this one!  
**PACE DVS-211**. Officially available only through Sky (racing) Australia (Bob Pankhurst tel 61-2-9451-0888).  
**PACE DGT400**. Through Galaxy offices, Australia (will not work on FTA if receiver has been over-air software upgraded [parental]).  
**PACE DVR-500**. Bay Satellite TV Ltd. (tel 64-6-843-5296); also supplied by NBC to affiliates.  
**Panasat 520 (Pn520), 630 (Pn630), 635 no longer available**. Limited spares from Antares Satellite (61-7-3205-7574)  
**UEC 642**. A notation - The (642) is currently available in test quantities only through Antares Satellite (see Panasat 520 above)  
**PowerVu D9223, 9225, 9234**. Scientific-Atlanta (Sydney) Tel 61-2-9452-3388; BaySat (tel 64-6-843-5296), Telsat (64-6-356-2749)  
 Note: SA D9223 receivers are RISKY to use for enthusiast purposes because of susceptibility to software overwrite during "boot-loading" sequence. Model 9234 is currently distributed in Western Australia for GWN reception under "RTIF" subsidy programme.  
**SK888**. Skandia Electronics Pty Ltd. (tel 61-3-9819-2466)  
**XTC CDTV200**. (For Space TV Systems); only source James Tzeng at (USA/tel) + +1-714-529-9988 or fax + +1-714-529-9989  
**YURI HSS-100C**. Rebadged Hyundai, software 2.27 which is Australian created mod from V2.26. Nationwide (61-7-3252-2947)

# WITH THE OBSERVERS

## AT PRESS DEADLINE

AsiaSat 3S is official replacement for failed "3" with newly announced intention of launching on Proton rocket not later than March 31, 1999. 3S will be identical to original 3 (see photo, below) with 28 C-band and 16 Ku-band transponders.  
(381 days - and counting.)

A persistent story (we do not label it a rumour) that a Pacific region digital Pay TV service plans to launch on Agila 1 (160.5E) deserves some comment (we have avoided making this report public until now out of consideration for the participants). The ex-Rimsat satellite from 130E was "hired" by a Filipino group in 1997 to act as an "orbit space holder" and renamed Agila 1. As Rimsat at 130E, legendary RAJ-TV used the 75 watt global beam of transponder 6 (3675 LHC) and delivered what was for the lifetime of RAJ on Rimsat the world's largest TV footprint. Alas, Rimsat at 130E was destined to self destruct since like all Russian Gorizont designs, it has a built-in inclined orbit pattern which by March 1998 sees the satellite wandering either side of the equator by 1.8 degrees. RAJ-TV bailed out of 130E late in 1996 and within six months 130E became 160.5E as an orbit space holder for the Filipinos. Between May 14 and 22 (1997), a New Zealand group calling itself *Impact TV* arranged for a re-test of the ex-RAJ power house transponder from 160.5E. This is apparently the only time the 75 watt super-powered transponder has been turned on since RAJ-TV vacated the spot back at 130E.

Impact was hoping to learn whether in being moved from 130E, the "global" super power transponder had lost any of its zip. In fact, eight days of testing produced mixed results and no real proof that this transponder, once capable of serving C-band antennas as small as 1.2 metres, could still do so. If 3675 at 160.5E could serve small dishes, there might be a business plan for Impact. Up to 8 digital programme channels (today - perhaps as many as 10 within six months) could be compressed onto the 40 MHz wide transponder. But there are difficulties. First, the satellite is now so inclined that north-south tracking would be mandatory even for dishes as small as 1.5 metres (if the transponder was activated today - wait six months and 1.2m dishes will require tracking). It would be difficult to create a DTH business plan requiring all dishes to track the moving satellite.

Second, Gorizont satellites have a "linearity" defect; that is, transponders were designed for analogue service, not digital. And no two transponders are alike, moreover the 75 watt power level TR6 is in theory most likely to have significant problems relaying digital. Creating a business plan for digital when you cannot be certain the transponder chosen is capable of relaying digital format signals is another element of risk.

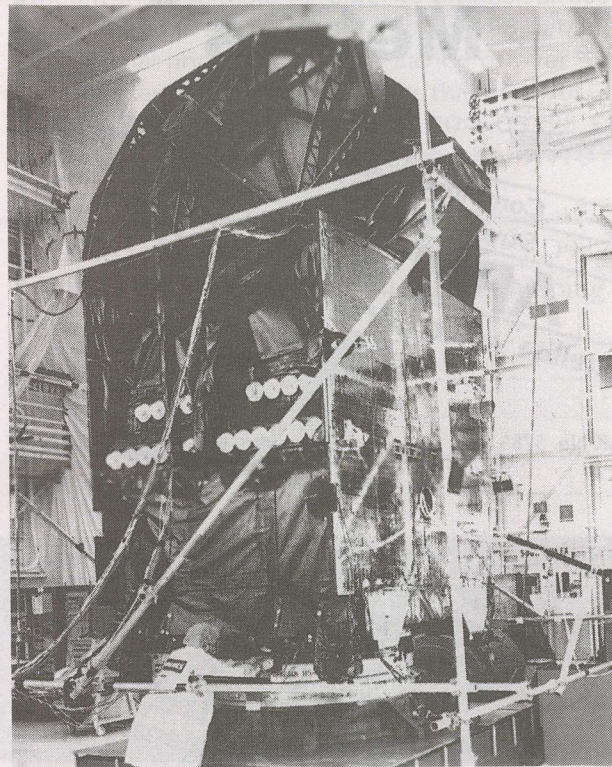

ASIASAT 3 during final check out at Hughes before ill-fated Proton launch error of December. How big is it? White object lower left is a technician!

Until MCPC is run through TR6 at 160.5E, and carefully analysed, there is no certainty a digital service will work here.

Any digital DTH service requires a healthy investment in IRDs. As we all now understand, either the IRDs are subsidised by the programmer or the public is asked to pay for them. If the latter case, very few members of the public will stand in line for a several thousand dollar DTH system. If the programmer pays some portion of the IRD cost, how does he justify bank rolling an IRD for a service that could at most only expect to last a year to 18 months because the satellite will become useless after that point in time? If the consumer is expected to pay for the IRD, how do you justify a several thousand dollar DTH system that will only play 12 to 18 months? Do you "promise" to find a replacement satellite when the first one fails?

**WITH THE OBSERVERS:** Reports of new programmers, changes in established programming sources are encouraged from readers throughout the Pacific and Asian regions. Information shared here is an important tool in our ever expanding satellite TV universe. Photos of yourself, your equipment or off-air photos taken from your TV screen are welcomed. TV screen photos: If PAL or SECAM, set camera to f3.5-f5 at 1/15th second with ASA 100 film; for NTSC, change shutter speed to 1/30th. Use no flash, set camera on tripod or hold steady. Alternately submit any VHS speed, format reception directly to SatFACTS and we will photograph for you. Deadline for April 15th issue: April 3 by mail (use form appearing page 34), or 5PM NZT April 4th if by fax to 64-9-406-1083.

# KONIG ELECTRONIC

## Field Strength Meters

KONIG  
ELECTRONIC

Combined Field  
Strength Meter

### APM 381

Satellite - Terrestrial - MDS

SK No. 5785

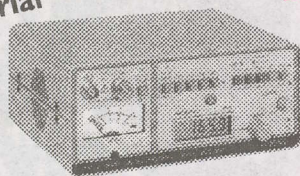

IDEAL  
FOR  
SAT TV - TV  
& MDS  
INSTALLERS

KONIG  
ELECTRONIC

IDEAL  
FOR  
CABLE TV & TV  
INSTALLERS

Hand Held Cable & TV  
Field Strength Analyzer

### APM 340

The Field strength analyzer  
of the future for TV and  
CATV facilities

SK No. 5777



KONIG  
ELECTRONIC

Field Strength Meter

### APM 746 SAT

Professional multistandard  
field strength meter  
for worldwide  
application

SK No. 5788

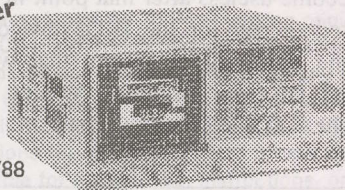

IDEAL  
FOR ALL  
PROFESSIONAL  
INSTALLATIONS

For more information on our full range  
of Konig Service Instruments &  
Specifications please contact:-  
Skandia (61 3) 9819 2466

Distributed in  
Australia & NZ by  
**Skandia**  
Skandia Electronics Pty Ltd

Victoria: 183 Burwood Road Hawthorn, Victoria 3122 Australia  
Telephone: (61 3) 9819 2466 Fax: (61 3) 9819 4281  
NSW: Level 1, 39 Terry Street, Rozelle, NSW 2039 Australia  
Telephone: (61 2) 9555 2955 Fax: (61 2) 9555 2455



EVER ELUSIVE - Myawady TV on AsiaSat 2  
(3766/1384 Vt; Msym 5.080, 7/8) as snagged by  
Steve Jepson (NZ) on 3m dish.

If there is a serious plan to launch a home DTH pay TV business through TR6 on Agila 1, it is a badly flawed business plan. At the end of the day, any DTH service has to have at least a measurable chance of making money. This one does not.

Robert Skilton (Te Anau, South Island, NZ) reports solid reception on Channel Master 1.8m dish and Sky NZ provided CalAmp LNBF from SPACE TV Systems digital bouquet from 177E. Thai 5 TV, FTA, is viewable without smart card on programme channel 301. Te Anau is close to furthest west (and south) one can be inside of NZ, and checking 177E footprint map (p. 6, SF#35, June 1997) indicates a predicted contour of 34.5 dBw. In fact, his signal sounds closer to 40 dBw which is contrary to other testing done with same service further north in NZ. Can we have others checking, please. 12.612 GHz Hz, Msym 26.694 and FEC 3/4?

Peter Dove (Victoria) reports instructions seen over normal PAS-2 test bars (4055/1095) with instructions to report reception quality to (USA) 707-253-0074. That would be Napa uplink site, a good number to keep on file.

Digital WTN London news feeds AsiaSat 2 (3786/1364 Hz) now reported encrypted significant part of the time. WTN HK (3775) and WTN Jerusalem (3790) less frequently active remain FTA.

Thaicom 3 (78.5E) target for digital: Reuters TV news feeds 3636/1514 Hz at Msym 5.632, FEC 3/4. Others: 3600/1550 Hz (Msym 26.662, FEC 3/4) and 3920/1230 Hz (Msym 28.340, FEC 7/8; David Leach, NSW).

TV audio on Gorizont 28 (90E) has been switched to 7.0 subcarrier from 7.5; all four TV channels.

Final location for InSat 2R (ex ArabSat 1C, now officially InSat 2DT) is 55E where testing is reported on 3811/1339 LHC. David Leach (NSW) reports InSat 2B/C (93.5E) reception from DDR National (4128/1022 Vt) and Metro Channel (4163/987 Hz). If you want a real challenge, look for signs of signal on InSat 2B/C's 4.530 /4.570/ 4.610 /4.650/4.650 /4 .690/4.730 channels. For reference, 4.730 equates to receiver IF of 420 MHz at 5150 local oscillator (!).

ApStar 2R Hong Kong test card reported 4188/962Vt in PAL. ZJTV, reported last month in FTA analogue 3760/1390 Hz) has been intermittent.

KIBC, buried inside bouquet carrying Hallmark (As2, 3940/1210 Vt), has begun scheduled daily programming for ex-pat Filipinos; some versions of Nokia e3 no longer will receive this FTA service. Steve Jepson (Levin, NZ) is

amongst those reporting Hallmark mysteriously again plays on (latest) version Hyundai as well as Benjamin DB-5000 he has been testing.

Austar's 12.689 tests on Optus B3 are now "linked" to Galaxy/Australis transponders at 12.373/12.438. Optus Vision testing on 12.564, 12.626 with active programme channels (8 per transponder at presstime); see p. 28.

PAS-7, intended for Indian Ocean Region, now delayed to "late 1998" scheduled launch (was April-June); PAS-8 for Pacific remains on schedule.

Palapa C2 changes continue: Indonesian TPI, formerly 4080/1070 Hz has moved to 4180/970 Vt (and for south of the equator, the signal has gone down on this new transponder). Reasons for change unclear, but it does appear Palapa is readying new uses for the "hot" horizontal transponders with new users likely on 4080/1070IF, 4000/1150IF, 3920/1230 Hz, 3840/1310 and 3760/1390 IF over next several months. Officially, HBO still scheduled to leave 4000/1150 March 30th as last of original B-MAC analogue services (ESPN, TNT are already gone), available subsequently only on C2 3500/3580 (Hz) Indovision digital package.

This one makes little sense. Palapa, owned by rigidly religious Indonesians who have frequently said they will not allow porno film channels on their satellites, seems to be allowing (or ready to allow) Indian adult film service on 3800/1350 Hz. "Plus 21," European in origin, on C2 is reported here testing from 1800 - 1900 UTC (6 to 7 AM NZ winter time). If this one actually works, they schedule (encrypted) adult flicks from 17.30 - 21.30 UTC.

Intelsat 180E changes for 3765/1385 Net 10 digital feeds: (1), (2) ABC feeds, (3) TV3 NZ feeds, (4) 10 Network feeds, (5) Globecast feeds. Only (5) is typically FTA.

## Scientific Atlanta D9223 MPEG Receivers A\$1450

AV-COMM Pty Ltd has sourced another batch of surplus receivers, this time they are Scientific Atlanta D9223 IRDs currently configured for PAS-2 free to air services. All units are pretested, rack mount IRDs suitable for satellite enthusiast use. Specifications can be found in our 1998 catalog. This special price represents a saving of over 50% on our current advertised price for this unit. All units are fitted with software version 1.20/1.05 (2). EMS shipping to New Zealand is available for A\$70 or airmail A\$50.

YES GARRY - Please send me \_\_\_ D9223 MPEG receivers @ A\$1450 each + shipping.  
Credit card # \_\_\_\_\_  
exp \_\_\_ / \_\_\_ Signature \_\_\_\_\_  
Name \_\_\_\_\_  
Delivery address \_\_\_\_\_  
p/code \_\_\_\_\_ Telephone \_\_\_\_\_

**AV-COMM PTY LTD  
(ACN 002 174 478)**

**198 Condamine St, Balgowlah NSW 2093  
Australia**

**Tel 61-2-9949-7417 Fax 61-2-9949-7095**



## Comet Installations is pleased to announce the acquisition of **ACESAT**



**which has now been relocated to our modern  
warehouse premises at 321 Parramatta Road  
Auburn, Sydney NSW 2144**

### Contact:

**Tenders, Design & Installations - Allan Miller (Operations Manager)**  
Phone: (02) 9704 2975 Fax: (02) 9704 2977

**Product Sales - Doug Sawtell**  
Phone: (02) 9704 2976 Fax: (02) 9704 2977

**Comet Installations is Australia's largest Satellite & Cable Specialist  
with extensive experience in VSAT, TVRO, SMATV, MATV,  
Multi-media Interface, Head Ends, DTH and Cable.**

COMET INSTALLATIONS PTY LTD ACN 071 673 562

SatFACTS March 1998 ♦ page 31

# AT

## Sign-off

### "Oh, Bother"

Children's character Winnie The Pooh, faced with a dilemma and unable to figure out a solution, shrugs his hunny laden shoulders and exclaims, "Oh, bother." There is a great deal of "bother" raining down on the 100 acre wood we call the home and commercial satellite world.

As reported in some detail in Coop's Technology Digest for March 4, on March 9th a pair of probably highly "bothered" engineering teams walked through a doorway at the Irdeto facility in Holland each hand carrying prototype MPEG-2 satellite receivers. One team from South African manufacturer UEC, another from San Diego representing Comstream (but the Panasonic brand name) were prepared for what could be the longest three weeks of their respective lives.

Back on February 24th, Irdeto (the conditional access firm) handed each IRD designer a new bit of software labelled "Irdeto version 3.5." Both firms rushed to their respective labs with the new release and began the task of "stuffing" (technical talk for "loading") the newest conditional access into waiting receiver chips. As SF#42 reported last month (p. 14), to be licensed to produce a receiver with Irdeto CA on board, the receiver must first be "Irdeto Certified." And thus the trip to Holland where Irdeto maintains a certification facility.

Half a world removed from Holland, a group of anxious engineers and management people will be chewing their fingernails waiting for daily reports on the progress. These would be the Optus team which has been working for nine months to get the (digital) Aurora project off of paper and into the air. Aurora is the Optus marketing name for conversion of all present B-MAC analogue TV services on Optus B1 and B3 to MPEG-2 digital. Optus, the satellite company, has a great deal at stake with Aurora. Competitor Telstra, teaming with offshore satellite operator PanAmSat, has already "stolen" likely Aurora customer GWN away. Others in the HACBSS (B-MAC) analogue world presently using Optus will have little choice but to follow GWN to PanAmSat (and that nettlesome upstart Scientific Atlanta) if Optus cannot get Aurora functional by mid-year.

Optus chose Irdeto as a CA system for Aurora with the best of intentions. Optus believes that sooner or later, when the present Galaxy/Australis (Austar/East Coast Television) mess shakes out, there should end up being a single digital encryption format for all of Australia. Optus believes Australia is badly served if consumers are required to choose between service "A" and "service "B" and then forced by that decision to acquire a digital IRD that works on one but not the other. Optus further has gone to considerable trouble, and some expense, to build their Aurora programme around the pre-existing Irdeto format conditional access - simply because Galaxy already uses it and to strike off in another CA direction (such as PowerVu, for example) only makes the eventual "rationalisation" of pay TV in Australia more unlikely. In all

of this, Telstra + PanAmSat + Scientific Atlanta are the bad boys; the guys bringing to town a non-compatible CA system which only serves to further delay cleaning up the Australian pay TV mess.

UEC and Comstream are competitors for what is initially a quite small order in the IRD world; 15,000 units to replace existing HACBSS and private network B-MAC with digital. Optus is on record stating they would like to have 3, even 4, different IRD models "approved" (by Irdeto) and in the Australian IRD marketplace. Optus wants us to believe they favour competition in pricing, IRD features, and service. If Irdeto "certifies" both the UEC and Comstream receivers being tested as you read this report, then it will be a race to see which firm (if either) can actually produce receivers to meet the most recent Optus announced self-imposed deadline to launch a full scale Aurora service. *That being June first.* If only one receiver is "certified," the race hardly slows down as Optus is being chased daily by the spoilsports at Telstra + PanAmSat + Scientific Atlanta with disparaging words designed to undermine whatever level of confidence the market may of once had in Optus and Aurora. If Optus misses the June first deadline for any reason, including not having version 3.5 Irdeto certified IRDs available for sale, you can be quite certain T+P+SA will be in there doing everything they can to convince Aurora contract users (such as ABC and SBS) to cancel their agreements and "come on board with PowerVu."

All of this for 15,000 receivers? Hardly. Not when it takes a minimum of 100,000 receivers just to recover receiver R & D (research and development) costs these days.

We all know that ultimately Galaxy/Australis will merge with, be acquired by or fall into a rationalised national DTH service package. None of us knows *who* will make up that package, but if the Optus Aurora programme using Irdeto CA gets on the air, using the same CA system as Galaxy, the chance that Optus (the corporation) will be a player in the final Australian rationalised package is greatly enhanced. If Aurora fails because of receiver snafus, and PowerVu pulls the HACBSS and private network business away from Optus, that greatly reduces the opportunity for Optus (the corporation) to be a major player in the rationalisation of Australian pay TV.

Is there any chance PowerVu could end up being the "rationalised" pay TV "standard" in Australia? Almost none (thank God!). And they know it, are happy to be "used" by Telstra in this power play for control of the pay TV industry just to get their hands on the 15,000 receiver order for HACBSS.

Optus, perhaps quite by accidental circumstances, is the "innocent party" in all of this subterfuge. Standing in the wings watching the drama unfold are big league pay TV operators Packer and Murdoch, while their minions circle the playing field looking for early signs of fatigue, defeat or mortal wounding of the participants. Packer smells "Pationalisation" while Murdoch only believes in "Mationalisation" and both are anxious for the "real" heavyweight contest to begin.

Irdeto is under intense pressure to overlook what CTD for March 4th reported are several "flaws" common to both the UEC and Comstream receivers (notably, software blocks that inhibit teletext and closed captioning from functioning properly). If Irdeto approves either or both receivers with flawed operational parameters, Aurora could win the June first time deadline race but lose in the field with imperfect receivers. "Oh, bother."



## THE 1998 SATELLITE EXPLOSION IN THE PACIFIC/ASIA!

### NEW PROGRAMME SERVICES COMING ON LINE MONTHLY - HUNDREDS OF NEW TRANSPONDERS SCHEDULED TO LAUNCH DURING 1998!

#### Stay tuned with SatFACTS!

- ENTER my 12 MONTH subscription to SatFACTS starting with April 15th issue (rates below)  
 ENTER my 36 MONTH subscription to SatFACTS starting with April 15th issue (rates below)

NAME \_\_\_\_\_

Company (if applicable) \_\_\_\_\_

Mailing address \_\_\_\_\_

Town/city \_\_\_\_\_ Country \_\_\_\_\_

**Amount to send:** 1 year - NZ\$50 (inside New Zealand) / A\$90 (inside Australia) / US\$60 (outside of NZ and Australia) or 3 years - NZ\$120 / A\$210 / US\$150 if by cheque. **VISA** or **Mastercard**? See form below and return with order. Return to: **SatFACTS, PO Box 330, Mangonui, Far North, New Zealand** or if by VISA or Mastercard fax to 64-9-406-1083

ALL SatFACTS SUBSCRIPTIONS ARE SENT VIA AIRMAIL - WORLD-WIDE!

### USE THIS FORM ONLY WHEN CHARGING ON VISA/MASTERCARD

Please charge my **VISA/Mastercard** as follows:

- ONE Year of SatFACTS MONTHLY (NZ\$50, A\$90, US\$60)  
 THREE Years of SatFACTS MONTHLY (NZ\$120, A\$210, US\$150)  
 SATELLITE TELEVISION: The Booklet (NZ\$10, A\$12, US\$10)  
 One Year of COOP'S TECHNOLOGY DIGEST (NZ\$125, A\$125, US\$125)

Indicate charge card type:  VISA  Mastercard

Name (as it appears on **VISA / Mastercard**) \_\_\_\_\_

**VISA/Mastercard** Number \_\_\_\_\_

**VISA/Mastercard** expiration date \_\_\_\_\_

**Instructions:** If ordering by mail, return this complete (3-part) card or a copy of same (to **SatFACTS, PO Box 330, Mangonui, Far North, New Zealand**); if order by FAX, send full card as a single sheet to **64-9-406-1083**

### SUPPLEMENTAL MATERIALS from SatFACTS MONTHLY: Order Form

- SATELLITE TELEVISION:** The Booklet. Excellent introduction to home dish ownership for the layman, including major contributions from the father of geostationary satellites - famed science fiction writer *Arthur C. Clarke*. The perfect tool to help the satellite system seller explain home satellite TV to the layman consumer. From SPACE Pacific. NZ\$10 / A\$12 / US\$10, airmail.
- COOP'S TECHNOLOGY DIGEST.** For the really serious enthusiast, investor, business person in satellite television and allied leading edge technologies. Ten issues each year, jam-packed with information you will not find anyplace else. "Coop" routinely culls more than 60 publications world-wide, terribly expensive newsletters, Internet and his hundreds of private contacts to keep you right at the leading edge of technology on the **REAL** changes underway in telecommunications. Conveniently issued near the **first of the month**, creating an excellent time-line-filler between the mid-month issues of SatFACTS. Now in the 5th year, airmail world-wide. Normally NZ/A/US\$250 per year - for SatFACTS subscribers special **50% discounted** price of NZ/A/US\$125.

# OBSERVER REPORTING FORM - Due APRIL 3, 1998

- NEW programming sources seen since Mar 1st: \_\_\_\_\_
- Changes (signal level, transponder, programming content) in pre-existing programming sources since Mar 1st: \_\_\_\_\_
- OTHER (including changes in your receiving system): \_\_\_\_\_

NOTE: Please use P1 - P5 code when describing signal levels and receiver IF/RF settings.

Your Name \_\_\_\_\_  
Town/City \_\_\_\_\_  
Make/size dish \_\_\_\_\_ LNB \_\_\_\_\_ Receiver \_\_\_\_\_  
Your email address \_\_\_\_\_ if you have one!

MAIL TO: SatFACTS Monthly, PO Box 330, Mangonui, Far North, NZ or fax 64-9-406-1083

## email - DO YOU HAVE email CAPABILITY?

**AN EXCITING NEW SERVICE from SatFACTS is coming. And we'll give you just one clue: "It is NOT monthly!" If you have email capability, and would like faster updates - return this card!**



+

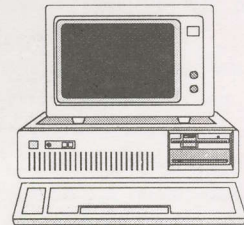

YES - I AM on-line with email!

email address \_\_\_\_\_

My name \_\_\_\_\_

Mailing address \_\_\_\_\_

Town/city \_\_\_\_\_

Mail or FAX this form to SatFACTS-Q, PO Box 330, Mangonui, Far North, NZ or fax to 64-9-406-1083

## SPACE INFO PACK?

Looking for the "inside track" to more sales and greater profits in satellite systems? The trade association SPACE Pacific may be able to help.

YES - Send membership details for SPACE Pacific to ...

NAME \_\_\_\_\_

Company (if applicable) \_\_\_\_\_

Mailing address \_\_\_\_\_

Town/city \_\_\_\_\_

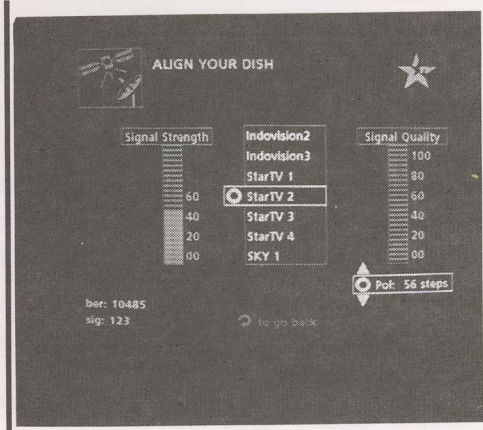

**SPACE Pacific Ltd.**  
PO Box 30, Mangonui, Far North  
New Zealand  
Fax 64-9-406-1083

# Year #30\* Filters For Cable TV • TVRO • Interference

## New 100 Page Filter Catalog

Has a filter for every application

- CABLE TV SYSTEMS
- SATELLITE RECEPTION
- OFF AIR INTERFERENCE

### CONTENTS

#### CATV:

- HISTORY
- BANDPASS FILTERS
- CHANNEL DELETION FILTERS:
  - Single channel deletion filters
  - Multiple channel deletion filters
- LOWPASS FILTERS
- HIGHPASS FILTERS
- CHANNEL REPROCESSING NETWORKS
- BANDSPLITTERS (hi/lo diplexers)
- PAY TV TRAPS & FILTERS:
  - History of CATV trapping
- INTERFERENCE SUPPRESSION
- NETWORK PASSIVES
- DROP LINE DEVICES
- WEATHERIZED HOUSINGS

#### TVRO: FILTERS TO SUPPRESS INTERFERENCE

#### BOOKS: CATV, TVRO, MMDS, INTERFERENCE

- APPENDIX A: INTERNATIONAL CHANNEL FORMATS
- APPENDIX B: INTERNATIONAL CHANNEL FREQUENCIES
- APPENDIX C: ORIGIN OF CATV, TVRO, PAY-TV

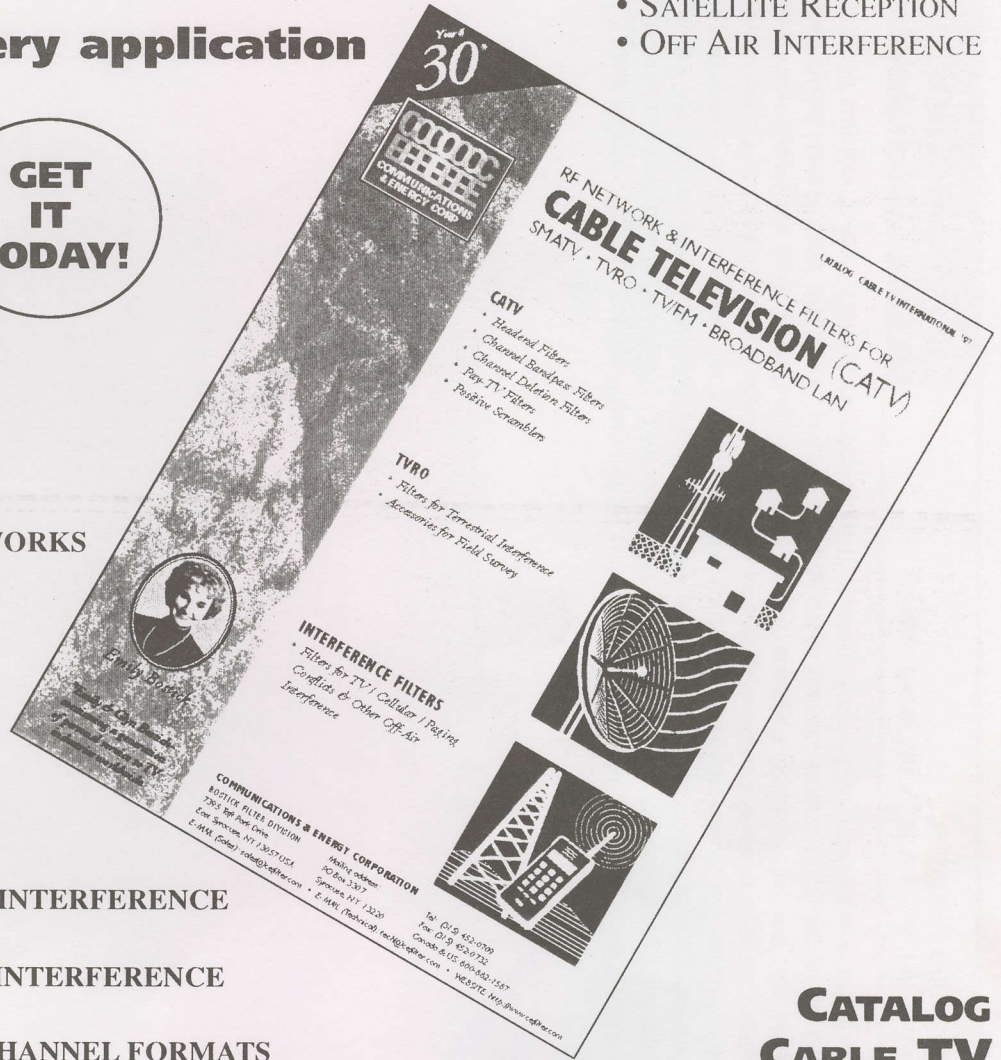

## CATALOG CABLE TV INTERNATIONAL/97

More than a catalog of products-  
It's also a tutorial on CATV history and practices.



Emily Bostick  
President

*Emily Bostick*

**\*Emily & Glyn Bostick -  
Continuing a generation  
of personal service to  
TV industries -WORLDWIDE!**



7395 Taft Park Drive  
East Syracuse, NY 13057  
Mailing address:  
PO Box 3307  
Syracuse, NY 13220  
Tel: (315) 452-0709  
Fax: (315) 452-0732  
Canada & US: 800-882-1587

## DISTRIBUTOR INQUIRIES INVITED

Telephone: 315-452-0709

Fax: 315-452-0732 USA

Literature: Ileen Feinberg

Technical: Dave Dann, Tracy Warren, Steve Shafer, Glyn Bostick

**"After extensive testing of competitive products, we have found the PDX MTA series 550 MHz trunks and LN series line extenders significantly better suited to South Pacific operating conditions than any other similar equipment currently available."**

Doubtless Bay Cable TV, New Zealand

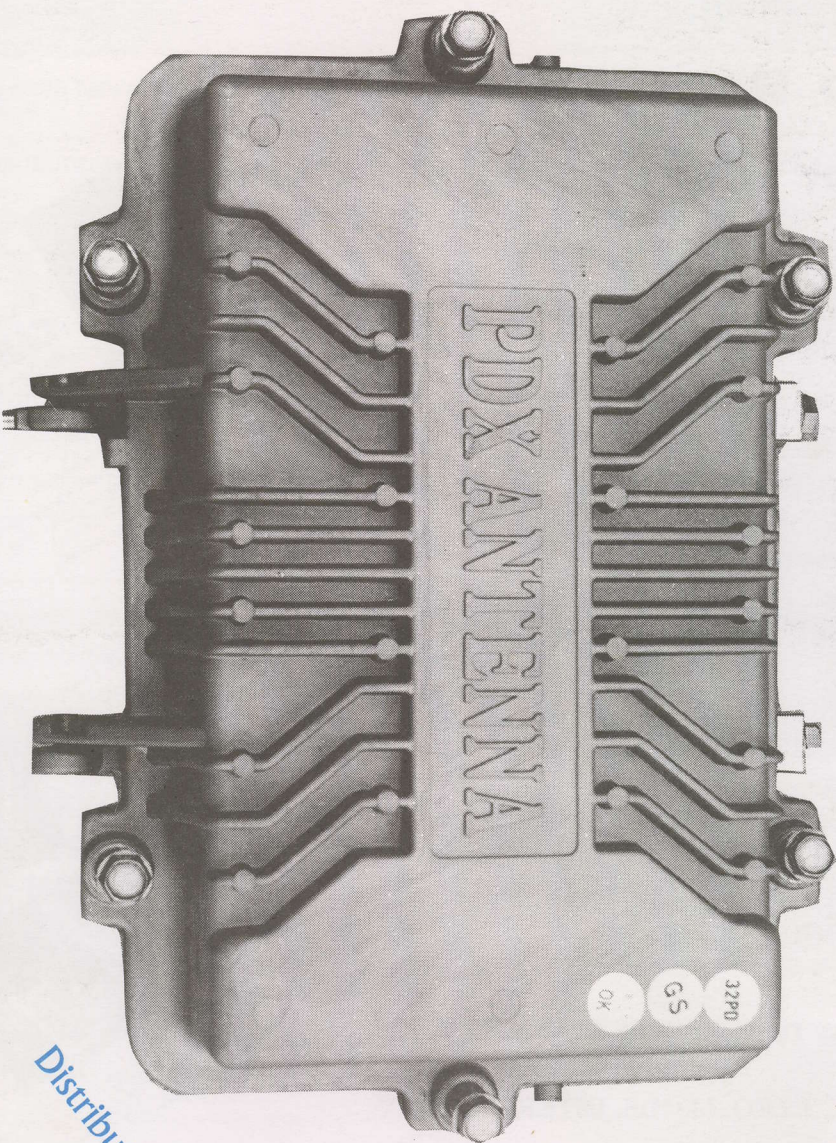

**Distributor Enquiries  
Invited!**

- MTA-550N/GS Trunk Series design choices:** Push-pull or power doubling ■ 54-550 MHz bandwidth forward (54-750 MHz modules available) ■ 5-30MHz reverse bandwidth with built-in duplex filter ■ 28 dB gain in manual operation, 32 dB gain in automatic (AGC/ASC) ■ Built-in -20dB input & output directional coupler test points ■ Plug-in automatic control module for slope and gain (uses system carriers at bottom and top end of bandwidth as references) ■ Exceptional heat dissipation, RFI integrity, moisture sealing against ingress/egress
- 35-75VAC line power operation with switching regulated power supply ■ State of the art cascadeability for long unattended trunk runs ■ Cost effective for low density cable plants, strand or pedestal mounting ■ Automatic transient, over voltage protection with current limiting for reliable operation

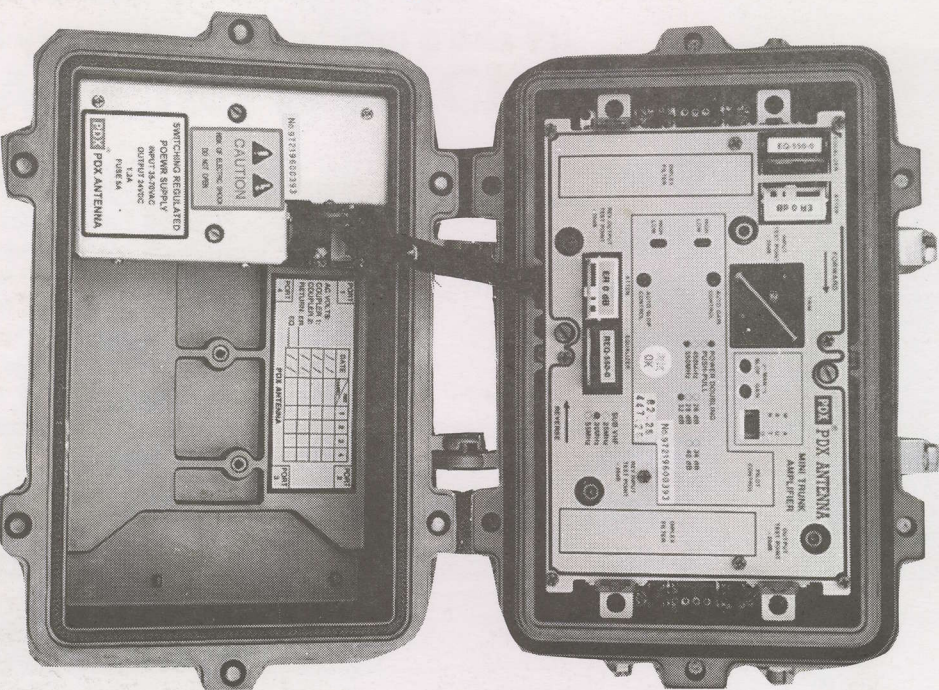

Model MTA-550GS/32D power doubling trunk (66 PAL format cable channels simultaneously)

**PDX ANTENNA MASTER CO., LTD.**

Mr. Peter Lin • 76, Sec. 2, Pei Shin Road, Tansui Town, Taipei Hsien Taiwan, R. O. C.  
Telephone 886-2-621-9600 • Fax 886-2-622-7157