

Bob Cooper's

DECEMBER 15 1997

# SatFACTS

MONTHLY



Reporting on "The World" of satellite television in the Pacific and Asia

## IN THIS ISSUE

**Throw Out  
The  
Satellites!**

**The KIBC /  
Hallmark  
Mystery**

**GETTING "Inside"  
HSS-100C  
Software**

- ✓ Latest Programmer News
- ✓ Latest Hardware News
- ✓ Latest SPACE Pacific Reports
- ✓ Cable TV Connection

**Vol. 4 ♦ No. 40**

Price Per Copy:  
NZ\$8/A\$9/US\$6





# Paraclipse<sup>®</sup>



CLASSIC  
SERIES

ECLIPSE  
SERIES

HYDRO  
SERIES

When quality, strength, and accuracy are your main requirements, **Paraclipse** antennas are your first choice.

Only **Paraclipse** offers such variety; four distinctly different series: the Truss-Ribbed Classic, the Courier Deliverable Eclipse, the Stretch Formed Hydro, the Commercial Patriot.

Every **Paraclipse** model sets the industry standard in its class, worldwide.

Distributed in Australia by  
**SKANDIA ELECTRONICS Pty. Ltd.**  
183 Burwood Rd, Hawthorn, Melbourne  
Tel 61-3-9819-2466 \* Fax 61-3-9819-4281  
Level 1, 39 Terry St, Rozelle, Sydney  
Tel 61-2-9555-2955 \* Fax 61-2-9555-2455

Distributed in New Zealand by  
**BAY SATELLITE TV Ltd.**  
PO Box 3311, Napier  
Tel 64-6-843-5296 Fax 64-6-843-6429

## Paraclipse<sup>®</sup>

HIGH PERFORMANCE ANTENNAS

Paraclipse Inc.  
2271 29th Avenue East, Columbus, Nebraska USA 68601  
Telephone: (402) 563-3625 Fax: (402) 564-2109

★ MADE IN AMERICA



# SPRSCS '98 RETREAT REGISTRATION

Are you a member of SPACE Pacific? If yes, skip section one.  
[SPACE Membership number (found on certificate \_\_\_\_\_)]

## SECTION ONE

- ENROL me/our firm as a member in SPACE Pacific as follows (select category)-
  - INDIVIDUAL MEMBER (no commercial interests in TVRO-DTH or Cable)  
[Annual fee is NZ\$30 per year]
  - INSTALLER / DEALER MEMBER (sell, service, install DTH-TVRO systems)  
[Annual fee is NZ\$75 per year]
  - CABLE TV or SMATV SYSTEM OPERATOR  
[Annual fee is NZ\$150 per year]
  - SATELLITE PROGRAMMER / EQUIPMENT MANUFACTURER/Distributor  
(including importers for wholesale distribution)  
[Annual fee is NZ\$250 per year]

## SECTION TWO

I WISH TO ATTEND (check all applicable)

- MARK LONG / SPACE Pacific Digital Satellite TV Course **February 17 and 18** and will be on hand by 10AM Tuesday February 17 for the course opening . I understand the course fee is US\$350 and this will be charged to my credit card on January 6, 1998 or is being paid at this time by enclosed cheque.
- SPRSCS '98 RETREAT **February 19 and 20** and will be on hand by 10AM Thursday February 19 for the retreat opening. I understand the Retreat fee is NZ\$275 and this will be charged to my credit card on December 5, 1997 or is being paid at this time by enclosed cheque.
- MARK LONG / SPACE Pacific Satellite Technician Installer Course **February 21 and 22** and will be on hand by 10AM on Saturday February 21 for the course opening. I understand the course fee is US\$240 and this will be charged to my credit card on January 6, 1998 or is being paid at this time by enclosed cheque.

## SECTION THREE

PAYMENT DETAIL (please complete and total as applicable at bottom)

- 1) NEW membership in SPACE Pacific as indicated above
  - 2) Digital Satellite TV Course February 17/18 at US\$350
  - 3) SPRSCS '98 RETREAT February 19/20 at NZ\$275
  - 4) Satellite Technician Course February 21/22 at US\$240
- Total (for both US and NZ currency as applicable)**

US \$\$	NZ \$\$
\$	\$
\$	\$
\$	\$
\$	\$
\$	\$



## SECTION FOUR

### REGISTRANT DETAIL

(only one registrant per form - if you are lodging with another registrant, see lodging below)

YOUR NAME \_\_\_\_\_

Mailing address \_\_\_\_\_

Town/city \_\_\_\_\_ State/District \_\_\_\_\_ Country \_\_\_\_\_

Telephone # \_\_\_\_\_ Fax # \_\_\_\_\_ email \_\_\_\_\_

## SECTION FIVE

### LODGING and ARRIVAL DETAIL

I will arrive (date \_\_\_\_\_) and require lodging for the nights of February \_\_16\_\_17  
\_\_18\_\_19\_\_20\_\_21\_\_22

I will require lodging for (number \_\_\_\_) person(s) for this period

\_\_\_\_ I do NOT object to sharing with another attendee to reduce lodging costs  
provided \_\_\_\_\_ (skip if not applicable)

Additional lodging requests (please indicate type of accommodations requested) \_\_\_\_\_

Note: Based upon this information, lodging arrangements will be made for you and in our  
confirmation the lodging details will be included.

## SECTION SIX

### TRANSPORT DETAIL

Notes: If you will drive or will arrange your own driving for the final leg Auckland to  
Doubtless Bay, simply tick top box.

- I am driving to Doubtless Bay and I can find my way to Mangonui on my own!
- I will fly to Auckland and then fly to Kaitaia on February \_\_\_\_\_ and request that I be  
picked up at the Kaitaia aerodrome at \_\_\_\_\_ local time
- I will fly to Auckland on February \_\_\_\_\_ arriving at \_\_\_\_\_ local time and request  
assistance from Auckland to Mangonui
- I am hopelessly inept at finding my way on my own and request your help!

## SECTION SEVEN - CREDIT CARD or CHEQUE DETAIL

I am paying by:

- Enclosed cheque to SPACE Pacific Ltd (amount from total in section three)
- VISA card  Mastercard

Number \_\_\_\_\_ - \_\_\_\_\_ - \_\_\_\_\_ - \_\_\_\_\_

Expires \_\_\_\_\_

in name of \_\_\_\_\_

RETURN COMPLETED FORM via fax (64-9-406-1083 if paying by credit card) or mail to SPACE Pacific  
Ltd, PO Box 30, Mangonui, Far North, New Zealand. Telephone queries to 64-9-406-0651.



# SatFACTS MONTHLY

ISSN 1174-0779

is published 12 times each year (on or about the 15th of each month) by Far North Cablevision, Ltd.

This publication is dedicated to the premise that as we enter the 21st century, ancient 20th century notions concerning borders and boundaries no longer define a person's horizon. In the air, all around you, are microwave signals carrying messages of entertainment, information and education.

These messages are available to anyone willing to install the appropriate receiving equipment and, where applicable, pay a monthly or annual fee to receive the content of these messages in the privacy of their own home. Welcome to the 21st century - a world without borders, a world without boundaries.

## Editor/Publisher

Robert B. Cooper (ZL4AAA)  
Office Manager  
Gay V. Cooper (ZL1GG)

## Reaching SatFACTS

Tel: 64-9-406-0651

Fax: 64-9-406-1083

Mail: PO Box 330

Mangonui, Far North

New Zealand

## Subscription Rates

Within NZ: \$50 p/y

Australia: AV-COMM Pty Ltd, PO Box  
225, Balgowlah, NSW 2093

61-2-9949-7417

Elsewhere: US\$60 p/y

All copies sent via airmail fast post  
world-wide

## ERRATA

SatFACTS Copyright 1997 by Robert  
B. Cooper; any form of copying is a  
violation of our international  
copyrights. Advertising rate sheet  
available upon request.

## COOP'S COMMENT

The failure of Australian authorities and the Australian television broadcasting industry to come to grips with the fundamental economics of pay television or even DTH has become an embarrassment. It will be interesting to see if 1998 "pay TV and cable trade shows" in Australia attract more than a small contingent of curious who are given free entry tickets by vendors desperate to justify their having spent megabucks to create a stand and transport a staff to the show venue.

The bottom line in a financial statement shows profit or loss. Altogether since pay TV began in Australia, the three major competitors (Australis/Galaxy, Foxtel and Optus Vision) admit to having lost more than A\$3 billion. That works out to A\$166.67 for every man, woman and child in Australia. Or, \$633.33 per Australian household. And those are only the "losses" to date and do not include probable additional losses from second-fiddle players such as Austar.

Everything about the Australian pay TV experience has been overspent. The staffs were far too large, the "experts" from overseas were overpaid for their advice, but most of all the Australian pay TV firms have paid far-far too much for the programming. With Foxtel paying Australis/Galaxy A\$25 per month for a handful of channels which Galaxy had the good fortune to acquire before Foxtel came into the picture, right away you know that somebody overspent by a tremendous margin for programming.

New Zealand's pay TV operator Sky has done only marginally better. Their good fortune is to have had smaller losses because of lower costs and to have had major league backers with very deep pockets. Still, their losses to date manage to be in the range of NZ\$115 per New Zealand home.

Pay TV in this part of the world first found root in Indonesia with the original four channel analogue Indovision package. A few months ago Indovision stopped feeding analogue TNT + Cartoons in a move designed to encourage people to switch over (at sizeable cost per household) to the newer (February, 1997) 20 channel digital package (presently on Palapa C2). Trade press reports suggest strongly the "incentive" did not work and people who spent less for fewer analogue channels are largely resisting the switch to digital.

Satellite TV attracts well intentioned, badly informed investments by people who probably exercise greater caution in their weekly selection of pet food at the local market. It is the magic of "show business" married to the lure of "space age technology" that keeps those cheques rolling in to support ill-conceived, poorly executed business plans. In New Zealand 56,500,000 "ordinary" shares in Sky (Network NZ) recently went public and was significantly "over-subscribed." When the new offering is over, Sky says Independent Newspapers Limited (part of the Rupert Murdoch empire) will hold 41.1% of the Sky stock. Additionally, INL will control Sky totally as NZ\$250 million in revolving bank credits negotiated by Sky last March carry a stipulation that the bankers will back Sky only as long as INL (read: Murdoch) controls and operates Sky.

Multi-ownership-layered pay TV operations are difficult to decipher and more difficult to make work as Australia has painfully learned. And the "hurt" has but just begun.

## In Volume 4 ♦ Number 40

Throw Out the Satellites (Robin Colquhoun) -p. 6

Hallmark, KIBC Present 'Mystery' -p. 12

Getting 'Inside' HSS-100C Software (Stu McLeod) -p. 14

## Departments

Programmer/Programming Update -p.2; Hardware/Equipment Update -p. 4;

SPACE Notes: Digital vs. Analogue Courses (Mark Long) -p. 20;

CABLE Connection: Limits of Amplification -p. 22;

SatFACTS Orbit Watch -p. 24; MPEG-2 Tuning Parameters -p. 26;

Digi Notes Reference Information -p. 28; With The Observers -p. 29;

At Sign-Off ("Mary" Christmas - Exxtasy is back!) -p. 32

## -ON THE COVER-

*You take a very small dish (45 cm), turn it upside down, point it at a terrestrial TV tower and connect the L-band signal to your computer. What do you get? Robin Colquhoun explains on p. 6.*



December 15, 1997



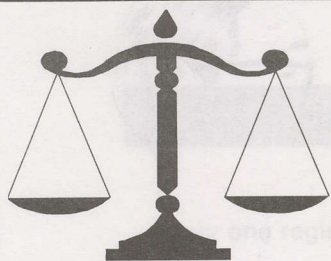

L  
E  
T  
T  
E  
R  
S

#### VELCRO Fix for HSS-100C

"Further to my report in SF#39, the noisy fan in the HSS-100C can be made dead quiet by removing it from the mounting board and placing two double-Velcro 'spots' between the fan's lower edge and the board. Now my family can sleep at night! I was also unable to resist taking the front end tuner from an e3 and replacing the Nokia brand tuner in my HSS-100C just to see what the difference might be. None is the report, although the Hyundai version Nokia tuner placed in the e3 was a total disaster. In a pinch, you could go from e3 to HSS-100C but not the reverse!"

Stu McLeod, Napier, NZ

Boys will play. The tuners, while both Nokia sourced, are not exactly alike as it appears the e3 version has more gain than the Hyundai version.

#### Still Not Happy With Hyundai

"I have now seen, evaluated, and formed a personal opinion regarding the HSS-100C version 2.25 software. My initial review of the Hyundai (SF#36, August, p. 6) came to what I considered a reasoned conclusion: The software was not user friendly. I performed these tests on a HSS-100C which I purchased; subsequently I sold the receiver to another enthusiast. When the 2.25 version software came along, I had the opportunity to install these new software chips and expected a considerable improvement. I was disappointed. Yes, the receiver now does RAI/ART, and the user features including the carrier to noise ratio calculation are useful. But the receiver remains painfully slow in searching, does not provide menu identification of channel listings (i.e., bouquet name, service ident) and once in the search mode will chase it's own tail forever in an endless loop until you pull the plug out of the wall or it stumbles onto something it recognises. I am no staunch supporter of Nokia and most everyone knows well my feelings about dealing with SA. My own hope remains that someone, someday soon, will get it right with a receiver that attracts more bouquets than brickbats!"

Robin Colquhoun, Auckland, NZ

We agree in part, disagree in part with Robin. That none of the present receivers "have it right" we agree; that "someday soon" a receiver designed to eliminate the present day glitch problems will appear, we disagree. What we see coming into the marketplace are cheaper versions of what we already have, not well thought out improvements. Receivers continue to be designed for specific services (such as Murdoch packages), not for general use and that we may one day have a perfect all singing, all dancing receiver remains elusive. A little reported Nokia e3 problem, by the way, causes the receiver to quit functioning with a green screen output. Solution? Pull the plug and start over.

## PROGRAMMER PROGRAMMING PROMOTION

## UPDATE

DECEMBER 15, 1997

Orion 3 satellite, scheduled October 1, 1998 to 139E, will "fit in" between ApStar at 138 and Russian at 140 by only using expanded C-band (3.4 - 3.7GHz) region; V and H polarisation. Satellite's C-band coverage is "interesting" because it will include all of Australia, New Zealand and significant portions of Asia within 33 dBw contours. On Ku, only two transponders are available for Australia - NZ - Pacific "Oceana Beam" but 1.5m dish size 40 dBw footprint does include eastern 1/3rd of Australia, NZ and all of the South Pacific. Orion operates Atlantic path satellite, plans Indian Ocean bird by 2000 to be competitor to PanAmSat. Company is now significantly owned by satellite builder Loral. Contact is Dieter Streit at tel/fax 64-9-529-0843.

RAI International has launched significant daily English language programming within the EBB AsiaSat 2 feed. RAI's

Giovanni De Luca, appearing at SPRSCS '97 last January, forecast major changes in schedule which we wrote about in some detail in SatFACTS 30 (February 1997, p. 1). Changes should make service more appealing to non-Italian speaking viewers although "Infomercial" portion seems like a curious choice for audience building. Will TV5 also "grow" to English content?

Hallmark service inside of ZakNet on As2. Service is presently taken from Measat at Subic Bay for turn around on As2; February-March start date, Hallmark will originate on tape from Subic Bay. Will ZakNet "move" to As3? That is one possibility; another is the service will expand to ApStar 2R as well.

EMTV's move to conditional access PowerVu involves SA model receiver (1590 kina from T.E. [P.N.G.] Pty Ltd. tel 675-325-6322) which supplier will not stock, only order upon your order. Yes - there is a waiting time. Worse yet, signal level from EMTV As2 service is 3 to 5 dB lower in level in PNG/Solomon Islands than reference EBB on same satellite. Good luck.

GWN (Golden West Network) began testing PowerVu December 1, PAS-2 Ku vertical on 12.263 GHz with Msym of 13.404 and FEC of 1/2. Two test programme channels initially, this Msym could support four video without difficulty plus radio, announced are GWN, ABC TV, WAFM and ABC radio.

Australian ABC has been on again/off again with FTA ABC service in PowerVu on 12.300 PAS-2 Vt. As has MediaSat relay of Australianised version of Sky News (London) on 12.286.

Star Movies will close down AsiaSat 1 service on 4180/970Vt December 31; no official word whether similar service on 3880/1270Hz will continue (through As3 when it turns on).

BBC digital audio on As2 3847/1303 Hz? Comstream ABR 200/202 receiver(s).

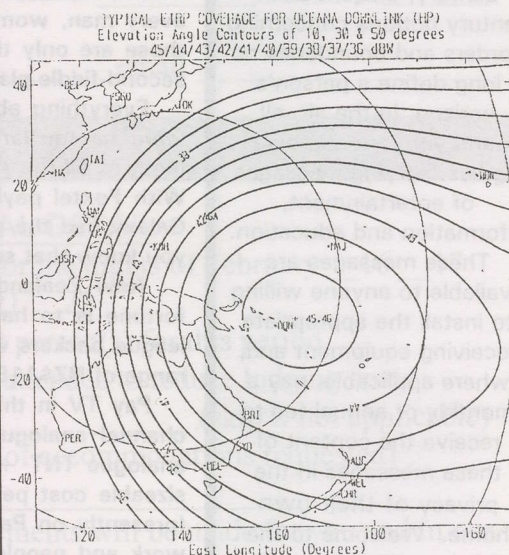

Orion 3 Ku covers NZ/Australia



HYUNDAI



Connect to the World...

# HYUNDAI Digital DBS Set-Top Box

HSS-100C

MPEG-2 (MP @ ML) & DVB compliance

## PROVEN PERFORMANCE

Power Vu  
DVB Compliance  
FTA

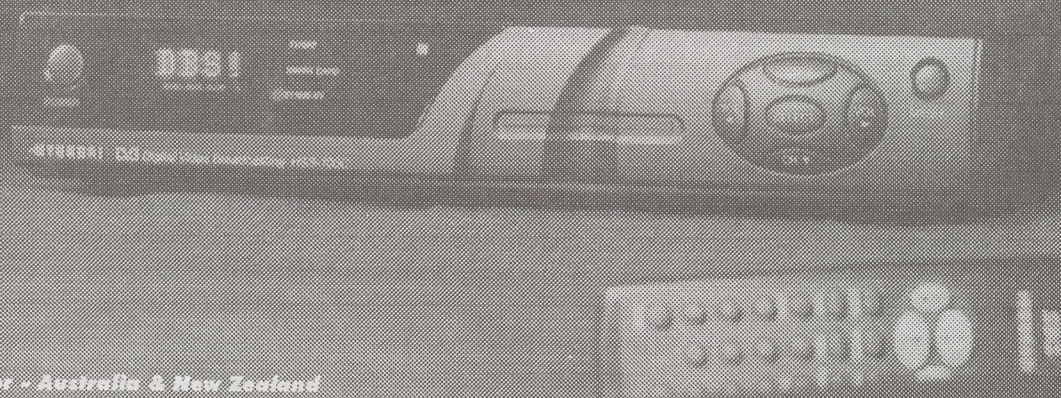

Distributor - Australia & New Zealand

**Skandia**

Skandia Electronics Pty Ltd

Victoria: 183 Burwood Road Hawthorn 3122, Australia  
Telephone: (613) 9819 2466 Fax: (613) 9819 4281

NSW: Level 1, 39 Terry Street, Rozelle 2039, Australia  
Telephone: (612) 9555 2955 Fax: (612) 9555 2455

- QPSK demodulation
- CD Audio quality (MPEG-1 Layer 1 & 2)
- Access up to 500 virtual channels
- Supports the aspect ratio both 4:3 and 16:9
- Easy-to-navigate electronic program guide



Bahasa Indonesia or Malaysian

"Reference photo appearing p. 29, SF for October. The announcement is in Bahasa (Indonesian and Malaysian - they are very similar) and it says 'This programme is for general viewing audiences.' Is this from The Hallmark Channel?"

Anthony Teh, WA

Thank you Anthony; yes, the announcement came from Hallmark's between feature ident; see p.12.

Death of D9223

"My SA D9223 has just died. I have been using it to watch the ABC news feeds on Optus B1 and had left it on for the afternoon when I noticed the display window said 'DL1-0.' I thought to myself - uhh-ohh! So I watched it for awhile hoping against hope it would somehow come back to life. It stepped through some sort of downloading sequence and then a message appeared reading, 'Table missing (xx seconds to reset).' It then reset totally on its own but when I now try to operate the receiver (turn it on) it just displays, 'Boot Loader - Waiting for signal.' I had previously set the network ID to '1' as suggested in SatFACTS. I will now be forced to return it to SA for repair at what may turn out to be megadollars (unless someone out there knows of a set of upgrade chips [ala the Hyundai]) or knows a way to reload the software with a laptop). Prior to all of this I had communications with the receiver using the expansion port and a laptop. Now it isn't even talking to my laptop. I did manage to record on video the last few minutes of my D9223's life and if anyone is interested, I could arrange a copy (which I may send to SA with the deceased unit). I am one very pissed off satellite user!"

David Knight email <dgknight@ozemail.com.au  
Tough break, David. Here's our view. SA sells D9223 receivers to anyone with the money. They make no attempt to warn buyers that under some circumstances the receivers can be rendered totally useless if they happen to be left tuned to a data stream which is in the process of upgrading receivers. This is a bit like selling a submachine gun to a ten year old walking in off the street and failing to give instructions about the dangers of such a weapon in such inexperienced hands. SA will claim nobody should have been tuned to the ABC news feeds unless they were in fact an authorised user of the service (and therefore part of the new downloading updating sequence). We believe that when SA or a PowerVu service provider intends to download new software, they are under at least a moral obligation to post a warning on the screen telling people "This is your last chance to get off this transponder before something nasty happens to your D9223," with a count down clock showing the time remaining to leave the transponder. Their past history of being totally user unfriendly, of having the worst service record in satellite television, and the most selfish and self centred public relations department in the business suggests they will continue to sell receivers to anyone with the bucks and continue to 'burn them up' for unsuspecting and unwary users. The ironic side to this episode is that had David been using a non-SA product (such as HSS-100C or Nokia e3) to monitor the ABC feeds, the downloading would have had no ill effects. For his loyalty to SA, for buying an SA receiver to watch an SA PowerVu service, he gets the shaft.

## HARDWARE EQUIPMENT PARTS

## UPDATE

DECEMBER 15, 1997

**AsiaSat 3**, the satellite, arrived at Republic of Kazakhstan Baikonur Proton launch site November 28th, is now rescheduled for launch December 22 around 2300UTC. The Hughes HS601HP satellite has 28 C-band and 16 Ku-band transponders on board; C-band coverage as previously detailed in SF (#31/March, p. 18) includes very large area from Australia/New Zealand north-west through the Middle East while Ku coverage consists of pair of beams to South Asia and East Asia plus a third steerable beam which will ultimately be pointed where the customer wishes. Assuming December 23rd is the launch date, test signals (from temporary testing location between 97 and 98E) should begin to radiate before January 15th. When testing is completed, bird will move to 105.5E and in one magic few hours As1 at that location will turn on while As3 will switch on.

**European Nokia** enthusiasts claiming they can go into e3 level receivers through 8 pin socket found inside of receiver on board with major software modifications to Motorola EPROM that controls such functions as NTSC reception, changing addresses directly. This, if true, is good news for hobbyists but of no practical value to consumers who simply wish to "point and view."

**Irdeto software** reportedly has been "cracked" by eastern Europeans and at least one Australian source claims to have two "pirate cards" which when inserted into appropriate CAM equipped receiver plays Galaxy services. But not without flaws - TNT, "channel 13" and possibly others either do not play or do so only intermittently. Street price being asked is A\$500 for a pirate card. No, we won't advise you where to go to find one - please don't ask!

**BBC World** service reception, PAS-2, within California bouquet seems to be having problems in scattered areas such as Bangkok, Hong Kong. Reception goes to pixels for several minutes - sometimes 30 minutes at a time. BBC says problem is not theirs, is sending complaints to PanAmSat technical headquarters in Florida. And they in turn are blaming individual dish installs. First - double check that you have total cross-pole nulling with the feed you are using as PAS-2 carries significant level of intermittent feeds on 3900 Hz, which will cause serious BER problems with 3901 Vt California bouquet if any of this cross-pole signal "leaks" into the D9223 receiver trying to recover BBC World.

**Mabuhay** on the move? Agila 2, combo C + high power Ku bird launched in August to 144E has now moved to 148E and according to Filipino sources, may move again. We understand Agila 2 never did have full international co-ordination completed, assumed "squatter rights" legal position for 144E and then ran into trouble with Japanese and Ku coverage. Very few transponders have ever been turned on - there could be technical problems as well.

**Supplier Sciteq** has activated web site ([www.sciteq.com.au](http://www.sciteq.com.au)) which lists the full range of satellite products now available with retail pricing. Dealer price discounts may be learned by qualifying dealers; contact Scott Nesbitt or Peter Merrett at (tel) 61-8-9306-3738. A 40 foot container of Orbitron antennas is due early in January, a second from KTI later in the month.

**JcSat 5** (Ku only) successfully launched December 2, going to 150E to replace "4" which will go to 128E - eventually. **Cakrawarta 1** (Indovision S-band) testing at 110E, will go to 107.7E (or thereabouts) when ready to operate.

**New Chaparral** data sheet describes model 11-7100-1 C-band LNB for 3.4-4.2 GHz, 20 degree, 65 dB gain. No word on price, delivery. **SA has appointed** first four regional Australian DTH distributors, training session Sydney December 15th.



# ADL<sup>®</sup>

BECAUSE PERFORMANCE IS ALWAYS YOUR FIRST PRIORITY

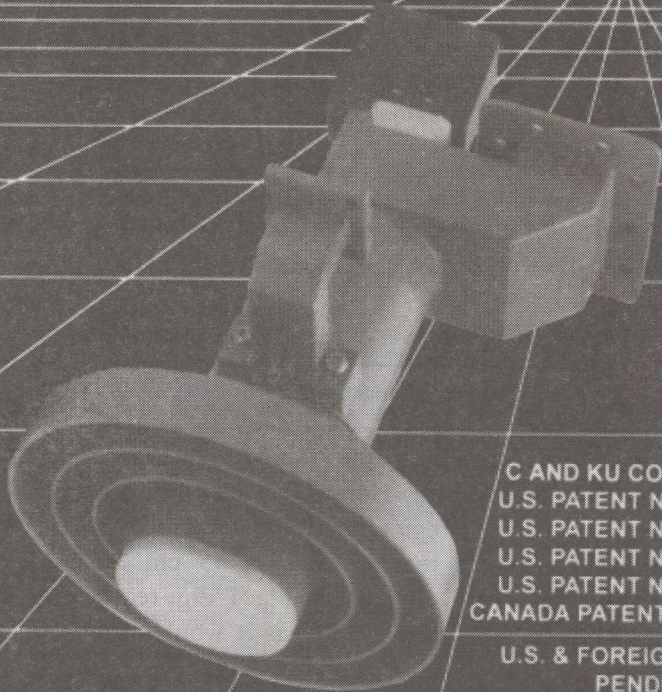

RP3-CKU/ International  
Adjustable Scalar Ring Feed  
with Extended C Band

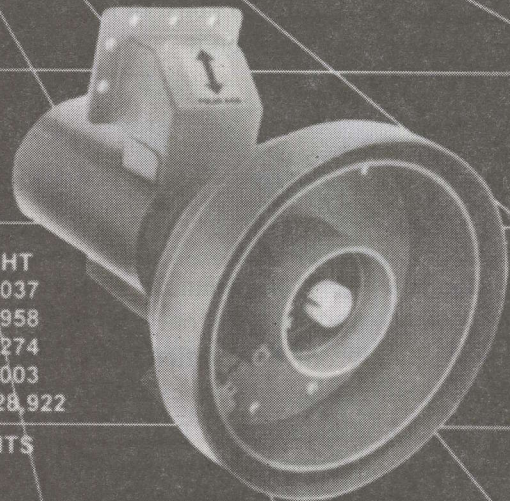

RPI-CKU Feed

C AND KU CO-BORSIGHT  
U.S. PATENT NO. 4,903,037  
U.S. PATENT NO. 5,066,958  
U.S. PATENT NO. 5,107,274  
U.S. PATENT NO. 5,255,003  
CANADA PATENT NO. 1,328,922

U.S. & FOREIGN PATENTS  
PENDING

## ADL HYBRID MODING CIRCULAR POLARIZED INTELSAT FEEDS WITH EXCLUSIVE T.I. REJECTION



RP1-CP400

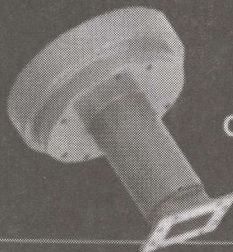

CP-300



CPOR-100

- C BAND LINEAR & CIRCULAR • C/KU LINEAR & CIRCULAR • KU 12 GHz FEEDS
  - INTELSAT 4 GHz CIRCULAR • ARABSAT S BAND FEEDS
- OPTIONAL: CO-BORSIGHT S BAND

2216 AGATE COURT UNIT B, SIMI VALLEY, CALIFORNIA 93065 • (805) 526-5249 • FAX (805) 584-0634

E-mail: [ADL@thegrid.net](mailto:ADL@thegrid.net) • Web site: <http://www.thegrid.net/adl/>



## FIRST - WE SHOOT DOWN ALL OF THE SATELLITES .....

With the development of MPEG 1.5 and 2 during the last 3 to 4 years it is now possible for the end user to have access to data streams for Internet and television at a cost significantly lower than just a few years back. And with the monthly improvements in software and data compression techniques, it can only get better and cheaper. It was less than a year ago during SPRSCS '98 that we all marvelled at the prospect of having satellite access to Internet via the Deutsche Welle VBI service at promised speeds of perhaps 70 kbps. In my home today, utilising a hybrid system built around PAS-2 Ku delivery of Internet delivery, a very small (45 cm) dish outfitted with a more or less standard LNBF connects to a PC plug-in card and delivers 3 to 5 meg files in as little as 5 minutes time. The same files delivered to my normal PC + modem connected via telephone line to my ISP of choice could easily require 2 hours of "downloading" time. This amazing new delivery protocol is presently available only in the Auckland region (and actually only in portions of the Auckland metro market) but is scheduled to expand throughout all of New Zealand, Australia and portions of the South Pacific during the coming months. This report will give you a first cut of what Internet "via satellite" is *really* all about, and how it will become available to you shortly, no matter where you are reading this.

Here is how it works. Basically, you are "hooked to" Internet but rather than receiving information back through your PC's telephone modem, the data comes to you through a 45 cm offset style satellite dish. The dish (see front cover) is mounted upside down. Why? The 12 GHz range signal originates not at a satellite but rather (in the case of Auckland) on a manmade structure; Sky Tower. For most locations, the incoming "elevation" angle is between 10 and 15 degrees and if mounted in the normal right-side-up fashion, the dish would be pointing at the ground (!).

The Internet Group (IG) has pioneered (in the South Pacific) the system shown in the diagram above. High speed Internet is delivered to Auckland (plus all of New Zealand and Australia) via PAS-2 Ku. IG receives the service on a quality 3m range dish, matrixes the USA based service with New Zealand and Australian content, and redelivers the merged data stream to a 12 GHz

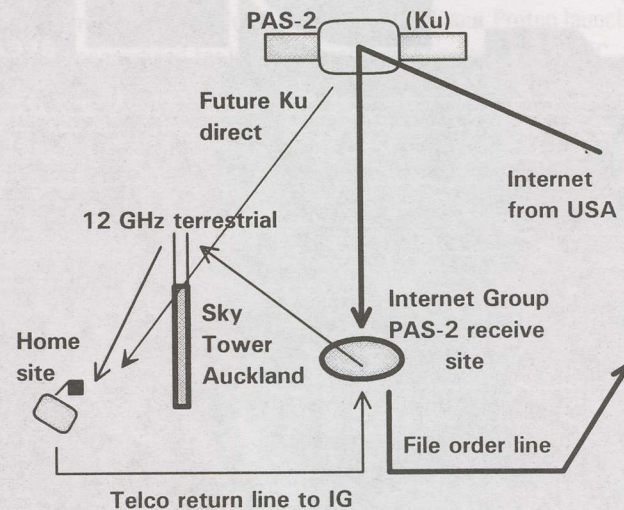

transmitter located at the top of Auckland's tallest structure; Sky Tower. Here a 4 watt transmitter beams the service over a region approximately 80 kilometres in diameter. At the receive sites, a 45 cm offset dish equipped with a digitally-stable ("digi-ready") LNB responds to the signal exactly as it would if the origin was a satellite.

The LNB down converts to L-band (950-2000 MHz) and the signal is transported to a waiting PC which is equipped with a special plug-in card through RG6 coaxial cable. The PC card is an L-band satellite data receiver or IRD only slightly different from your MPEG-2 DVB Compliant IRD.

A user still requires a PC, a modem and software to connect to Internet. The PC + modem + software allows contact with an appropriate ISP (Internet Service Provider). The ISP acts as an "order desk" and the user communicates with the ISP the specific web site, data file or other Internet available material requested. In a normal Internet world, once the request is made, the user "stays" on the (telephone) line through the modem until the requested information is found in the vast Internet world. Once found, the ISP's commands ask the information source to "download" (provide data access) for the user through the telephone modem.

In the IG world, the user stays in modem connection with the ISP to verify the successful download of the requested files from Internet USA to the Auckland region customer through the satellite feed/45cm dish.

Through the ISP's direct tie-line to the USA Internet base, the user request identifies the required data site. When found, software grabs the desired data stream and inserts it into the current PAS-2 Internet stream flowing

by Robin Colquhoun, Auckland, New Zealand  
with thanks to Tim and Nick Wood of (the)  
Internet Group.



away from the United States. With no hands touching it, the stream is taken down by IG in Auckland, linked on to the Sky Tower transmitter site and then broadcast over a relatively short terrestrial path to the original terminal that requested the data file. The local ISP modem connection validates the correct receipt of the files.

Why go to all of this bother if the user could have simply "stayed on the line" through the modem and received the same data? *Speed*. And time is money.

Internet via two-way telephone modem can be very slow; sometimes as slow as hundreds of bits per second (bps). A delivery rate for a file in the region of 2 or 3 kilobits per second (kbps) is high average. The larger a file, the longer it takes to effect a download. A file with megabits (millions of data bits) can take hours to download. And of course even if the user's time is worthless, the longer you are connected to Internet through a telephone modem, the greater the connection cost.

So this is all about speed. And costs. How much speed?

The Internet Group suggests delivery speeds of 200 to 500 kbps with the system described here. *Honest report?* The software tells you the delivery speed when it is working and my own experience is speed to 70 kbps (and as little as 10 kbps); both numbers are better (significantly better) than two-way telephone line modem connection. Faster speeds are certainly seen with New Zealand data sites and I have little doubt the overall "overseas" delivery speeds will greatly improve as refinements are added to the system. My experience is that a 3 to 5 meg file using the IG "Star Net" (12 GHz) radio link is complete in 5 to 10 minutes time whereas using a standard telephone modem at the best (least Internet use) time of day 2 hours would not be unusual.

#### The System

Satellite delivery of requested data is certainly the wave of the future. Regular readers of this publication (and Coop's Technology Digest) are already well aware of the cutting edge technology that is happening all around us on various satellites. The IG system may be a final form or it could simply be an interim method of delivering Internet while the more obvious "satellite-direct-to-PC" service approaches commercial consumer

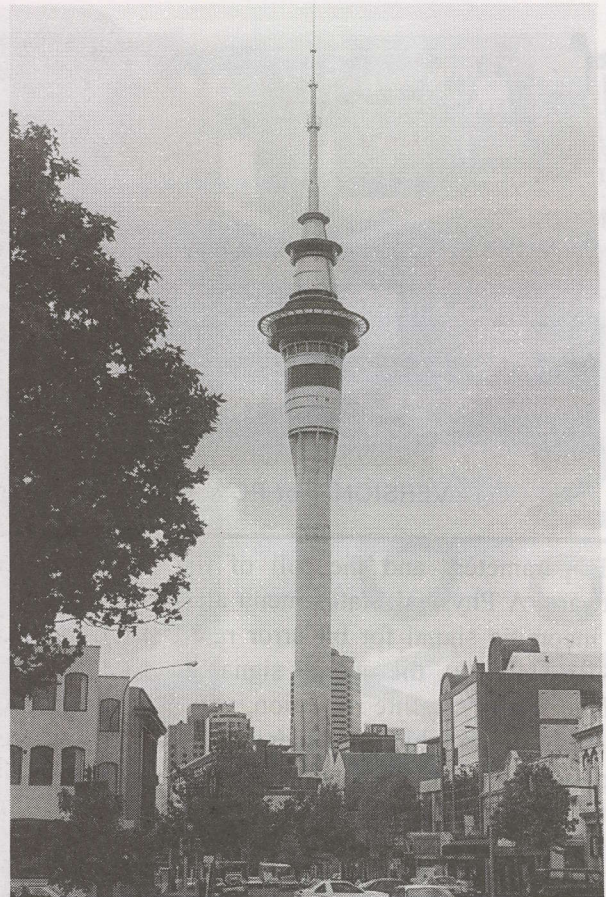

4 watts at 12.366 GHz with the transmitter only kilometres away is significant signal. Sky Tower rises well above most receive locations requiring satellite-like elevation angles for each dish install.

viability. The IG system consists of the afore mentioned 45 cm dish, mounted upside down for terrestrial use, a digi-ready LNBF, normal L-band installation practices and a custom created PC expansion slot "card" which combines an L-band MPEG data stream processor with normal L-band signal processing. The full length card (see page 8) fits into your Pentium level (or, possibly, a suitable 486) computer; the L-band coaxial feed connects directly to a standard "F" fitting at the rear of the card.

The computer runs on Windows 95 (Windows nt) or Windows 98 Beta (version). There are three primary menus (see page 10) that allow the user to define what the system will do. A Configuration Menu allows the user to establish the data PID, FEC and symbol rate, the



Line of sight transmission from Sky Tower provides cell-size satellite coverage of Auckland metro region



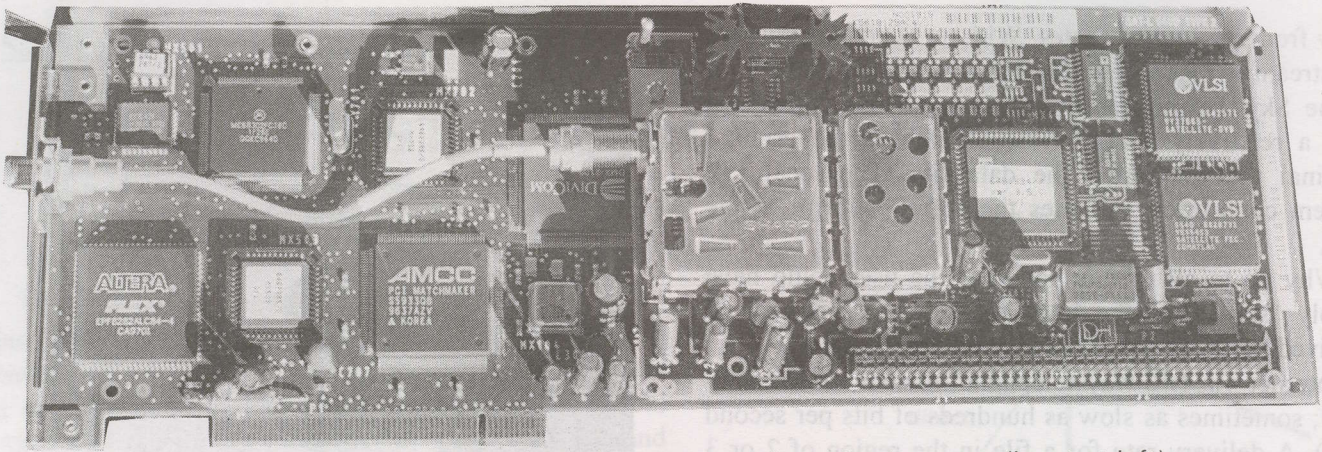

VERSION 1 of PC card board had tuner (L-band) section in centre (input at left)

LNB parameters and the roll of the Solomon Reed software. A Physical Status menu allows monitoring of the incoming signal for bit error rate (BER), the AGC (LNBF stability), the overall signal level (which is, in comparison to satellite reception, very hot!) and system synchronisation which includes the IP address manager display set for a specific address for your site (allowing the ISP to direct files to your terminal).

The final menu is "status" which confirms if the software and card have been properly installed.

A few words concerning the PC cards. IG has already gone from prototype-used-for-test (top photo) to 2nd generation (bottom photo). The original had the tuner mounted on its own board, which in turn was sandwiched to the main board (card). The production version moves the tuner to the rear but uses a single card. It is difficult to pick out, but a conditional access (smart) card 'slot' is included. The smart card gives IG room to grow their service without board change out; good planning for the future. To demonstrate an additional capability of the system, during the home computer show (November 22-23) in Auckland, a colour

camera was set up to display the IG help desk in operation - later moved to show an outside street shot. The video ran in real time DVB MPEG at 4.6 megabits per second and certainly proved the feasibility of marrying video (and audio as you wish) to a common data stream.

Instinctively I began a search for 'other' MPEG Internet cards for PC use, not unlike the perpetual search for the perfect satellite IRD! There are several out there in the marketplace but be warned: Virtually all manufactured utilise their own proprietary technique to process the TCP/IP protocol or high speed Internet data. What that means is that while video processing may be "DVB Compliant," the actual software protocol used to access the Internet signal may not be compatible with the satellite data stream. And there is

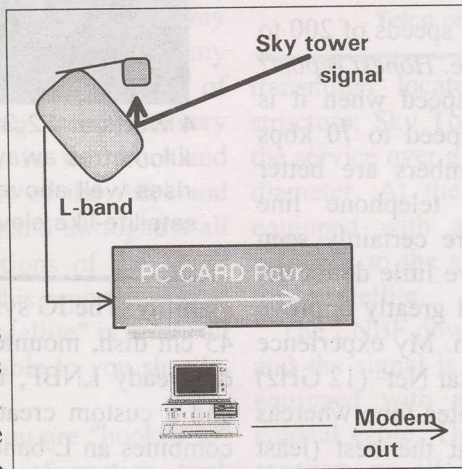

already an Internet "data stream" on C-band satellite as some are aware.

A very similar approach is taken by satellite delivered Zak Net which is presently found on AsiaSat 2 (3940 Vt). SatFACTS readers will identify this feed as being a part of the same transponder (uplinked from Subic Bay,

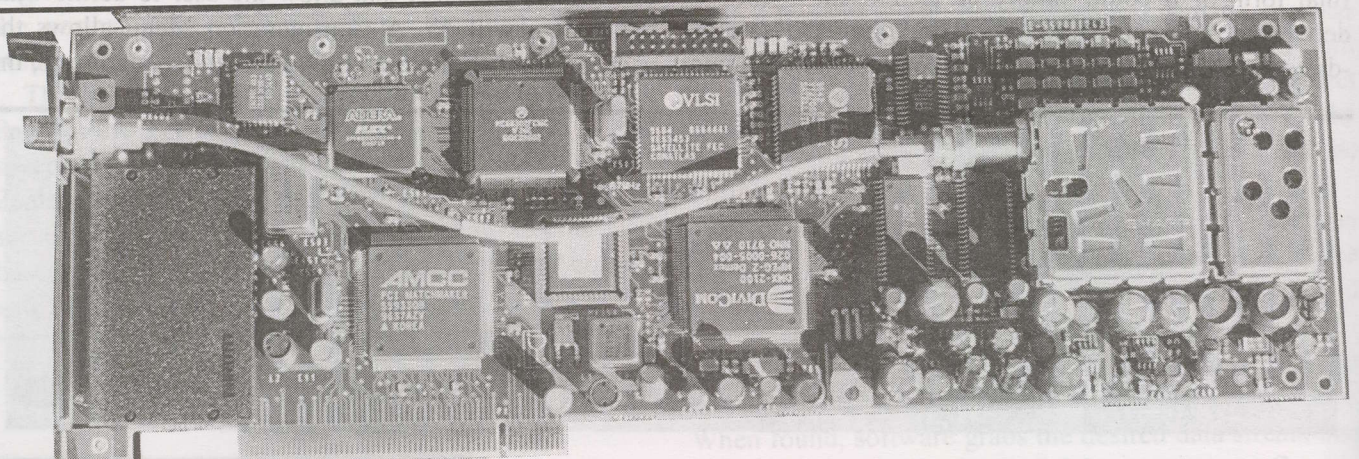

VERSION 2 (current) - tuner at far right



# The Nokia Mediama<sup>ster</sup> DVB 9500 S.

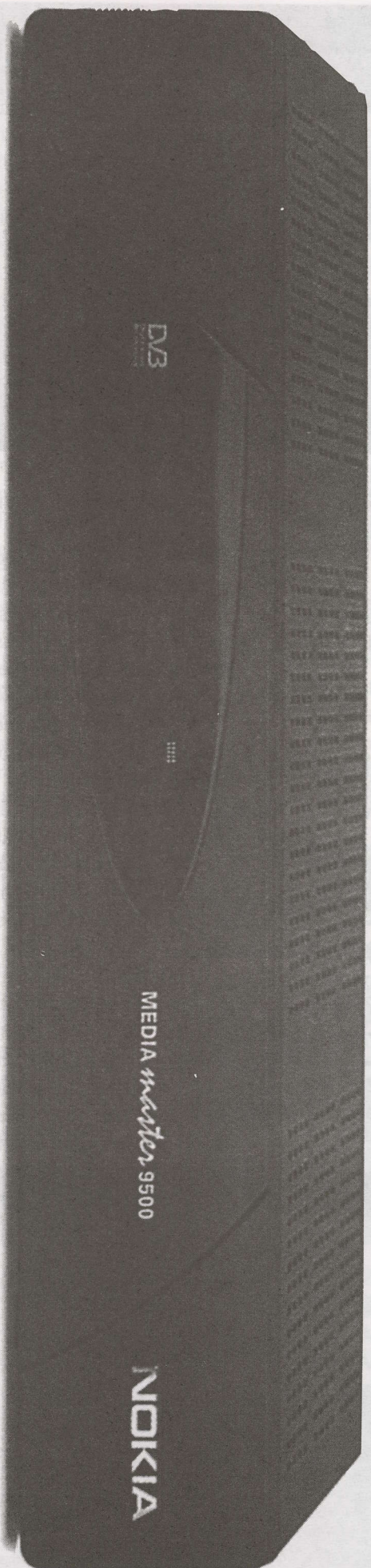

Brings the power of multimedia to your TV.

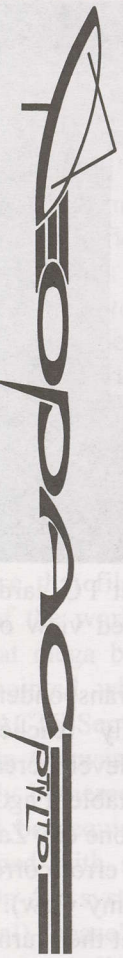

TEL 61-2-9584 1233 • FAX 61-2-9584 1452

• 99-105 BOUNDARY ROAD, PEAKHURST NSW 2210 AUSTRALIA • Email [opac@internet-australia.com](mailto:opac@internet-australia.com)



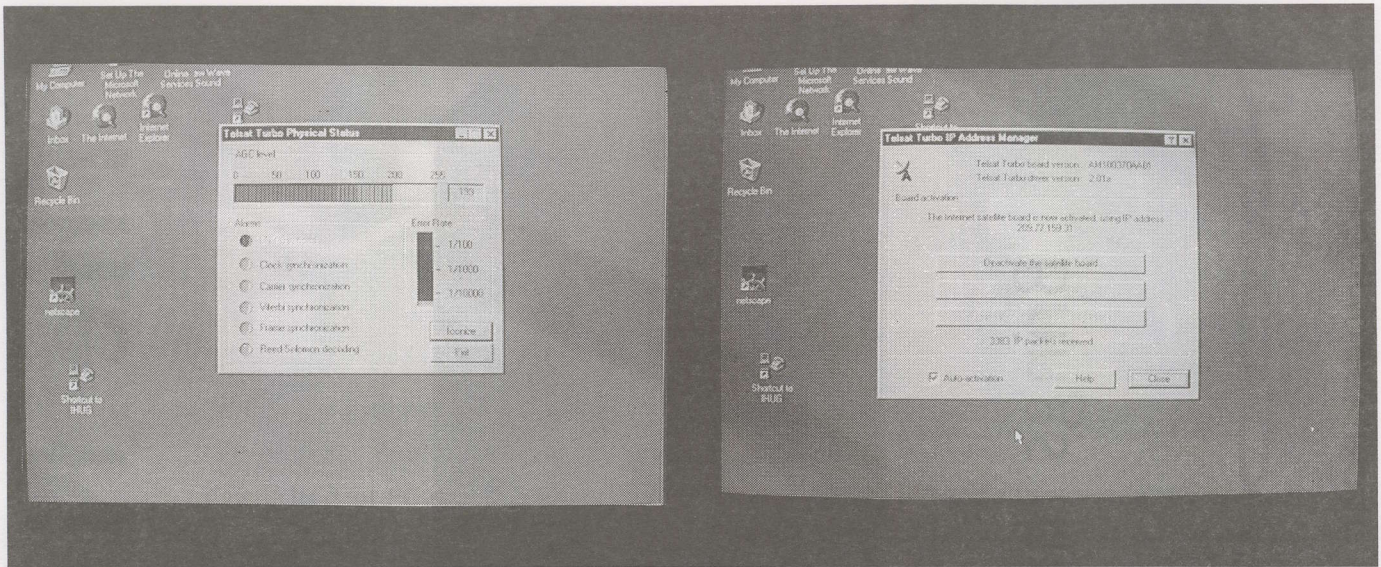

the Philippines) that provides Hallmark Entertainment Television and the new KIBC (Filipino) ex-pat service. In fact, Zak Net's Internet delivery is actually indistinguishable from Hallmark and KIBC from a transponder loading vantage point; the TV services are simply "buried" within the much larger Zak Net Internet service as a piece of the complete data stream. Does this suggest that a service such as IG could also be delivering television programming as well? We'll return to that in a future issue.

When Zak Net began testing on AsiaSat 2, I was fortunate to be able to arrange for test of the service through a "loaner PC card" provided by that firm's Australian representative. My Zak Net experience was as follows:

1) First, New Zealand's look at AsiaSat 2 is always below 5 degrees and while some have had reasonable success with this low look angle, MPEG data stream service is at best disturbed by anything in the system that compounds the opportunity for errors. I do not have a good view of As2 and ultimately my success rate was

1/ Any reader with first hand Zak Net experience in Australia is asked to make a report to SatFACTS.

only improved by moving the Zak Net PC card to a downlink terminal with a less obstructed view of this satellite.

2) The footprint level for this transponder was immediately suspect and I eventually reached an appropriate person at Zak Net to get the level increased.

3) Then it was better but still unacceptable. I agonised about the high error rate until I realised one day Zak Net was operating with their Solomon Reed error correction switched off (not the best approach, in my view). After advising them of this deduction, Zak Net then turned on the Solomon Reed software. The Solomon Reed switched off allows the service provider to increase the bandwidth (data stream flow) but in the process increases the errors.

All of this consumed several months time and I admit that at about the time they said my suggestions had been followed, the IG system came along and I lost interest in fighting such a low look angle battle. The rumour that Zak Net could be moving to AsiaSat 3 is welcome here - certainly if this does transpire early in 1998, the 5 degree higher elevation angle will make experimentation with their service attractive once again. I do understand from their Australian representative the service is functional with only normal teething problems in

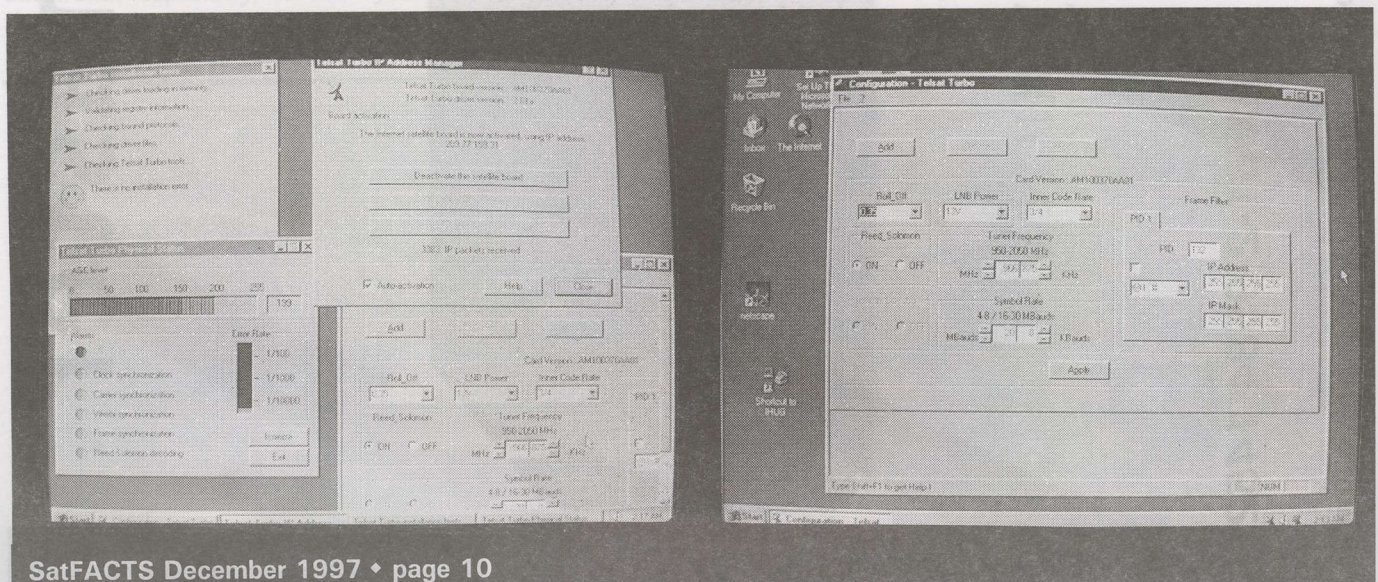



Australia, where the look angle is much more acceptable (1).

### Move Fast - Carry A Big Stick

I like new "toys." Internet, to me, is a tool and I realise that for many people it is a passion; a way of life. In the satellite field, there are hundreds of web sites and useful data files which are available to me only because I know enough to use Internet. I, like most Internet users on a budget, become quite exasperated when it takes "too long" to locate a particular site, or page or file. I become even more unhappy when because of traffic loading on the terribly outmoded telephone lines a file I have requested crawls into my PC at speeds that are often slower than a fax machine.

As a satellite enthusiast, I think it "magic" to see the promise that files can be uploaded from the opposite side of the world and downloaded to my PC one day soon at mega bit per second rates. I, like many, was disappointed when the Net-On-Air saga turned sour (SatFACTS September and October 1997; p. 32). When Net-On-Air was first introduced to us at SPRSCS '97, nobody bothered to explain that to use the system we would be required to purchase \$3,800 NTL receivers equipped with special \$1,000 processing boards. The Net-On-Air system utilises the VBI (vertical blanking interval) "space" to deliver one-way Internet data flow. It does not allow individual users to request specific files or web sites and is useless for email delivery. Very little of this was properly explained in advance.

Similar VBI or one-way only concepts have been advanced by firms that should be knowledgeable about what will and will not satisfy the public's thirst to be "Internet connected." It is my view that any system that requires special skills, training or a dedication to the "technology of Internet" will be a marketplace failure. I cite two examples: When TV4 came on the air in New Zealand, utilising standard VHF TV channels last June, the network actually paid a sizeable crew of part-time people (mostly university students) to go into the field to help tens of thousands of consumers locate the new TV channel on their TV sets. In the UK, when TV5 began broadcasting earlier this year, 20,000 people were hired to go to more than 5,000,000 UK homes to assist viewers with tuning their TV sets and VCRs to the new channel. That, sadly, is the real world. (2) Internet connection, requiring average home viewers to learn a new "language," train for new equipment operating skills, plus spend hundreds or thousands of dollars for the privilege of accessing web sites that offer chocolate flavoured condoms for sale is not the real world.

I believe people who have already made the effort to become Internet conversant will invest in faster speed delivery only if an improved system actually makes a

2/ And after this was done, TV4 manages to attract less than 1% of the total TV viewing audience on average while the UK's TV5 has fewer than 2% tuning in. There is a strong message here

significant difference to their personal use of "the net." "Faster" is right up there with the first decade of colour TV. Everyone knew it was better, but it took more than ten years for homes using colour to pass the 50 percentile mark. VCRs, starting from "0 penetration" (whereas TV sets started with 90% penetration in black and white), also took ten years to reach 50% home penetration.

Satellite delivery of Internet, no matter how good, will represent a surcharge on a specialised set of equipment (PC, modem, software) that is being promoted as "necessary" to gain Internet access. Will the "average" home be willing to spend an extra \$1,000 or more to get "faster Internet" on top of the first \$1,000-\$3,000 required just to get initial Internet access?

I love toys. But like any other working family, we have a budget which dictates which toys and when. As a technology freak, I will always be on the leading edge of consumers. But ten years after my first satellite dish, I am still "the only kid on my block" (or, indeed, for tens of blocks around me) with a dish system. SatFACTS readers, on a scale of global movement, are at the speed of light. Unfortunately for new technology, we do not represent the mass market required to make any new technology a success. I wish the Internet Group well, and will assist them in every way to take their technology direct to the masses via satellite. Ted Turner said it: *You can always tell a pioneer by the arrows in his ass!*

## NOT COMING TO A NEWSAGENT NEAR YOU

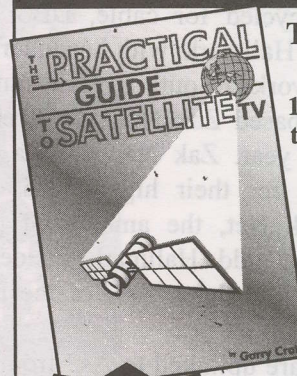

**NEW!**

### THE PRACTICAL GUIDE TO SATELLITE TV

116 easy to read pages, explaining the history, theory, operation and installation of *HOME SATELLITE TV* systems.

221 explanatory photos, tables, graphs and diagrams.

46 pages of satellite orbital data, transponder loading, footprints for every satellite covering Australia and neighbouring countries and comprehensive glossary of terms.

**AVAILABLE NOW - \$39**

**AV-COMM PTY LTD**

A.C.N. 002 174 478

198 Condamine Street,  
Balgowlah NSW 2093

Tel: (02) 9949 7417/9948 2667

Fax: (02) 9949 7095

<http://www.avcomm.com.au>

✓ **YES GARRY, Please send me 1 x Practical Guide to Satellite TV priced at \$39 + \$5 p&p (NZ \$8 p&p) Australian \$ only**

Credit Card

Signature

Name:  Expiry Date:

Delivery Address:

P'code:  Phone:



## KIBC JOINS HALLMARK BOUQUET -DIFFERENT RECEIVERS FOR DIFFERENT STROKES

Just when we thought every possible variation of bouquet parameters had been encountered, along comes a new one! Here now is a two programme channel bouquet (MCPC) which requires one software format to receive one of the programme channels and a second set of software for the second service. Two separate receivers no less!

It all started innocently enough. The Hallmark Entertainment Network has been coasting along buried inside of a more complex full transponder Internet data stream (As2, 3940 Vt at 26.655 and 2/3) for several months. When originally reported (May) the video and audio would play on a Nokia e3 and that was about all. Within a month, the video had disappeared except for brief periods of time. The service was not encrypted - that was evident - but it was not working on DVB Compliant receivers either. At least not reliably and then not for very long.

Hallmark is a US based company that began sponsoring teleplays back in the 1950s. Now they produce full length made-for-television films and in 40 years have collected several thousand such programmes in a vault. This is the same "Hallmark" that markets greeting cards, by the way. And just as TNT movies are recycled for pay TV play, so too are Hallmark productions now being recycled for cable, DBS and other pay-to-view ventures. Hallmark, with headquarters in Denver, Colorado, worked out a distribution arrangement with Kuwait based Zak Net (the Internet delivery firm) earlier this year. Zak Net takes a full transponder on AsiaSat 2 for their high speed data stream distribution; to Zak Net, the amount of data stream "space" required to add Hallmark inside of Internet is relatively minor - perhaps 10% of the total stream capacity.

Zak Net (and Hallmark) are uplinked to As2 from the old Russian operated Rimsat facility at Subic Bay (Philippines). Hallmark in turn is taken "down" at Subic Bay off of the Malaysian Measat feed; on rare occasions while watching Hallmark through Zak Net you will see the Measat receiver warning "Invalid authorisation card" or some other nonsense. Hallmark originates at Measat uplink control (see SF#29/January 1997, p. 6) on tape supplied by Denver.

So while Hallmark was not exactly encrypted, it was also mostly not available until approximately September. That was when adjustments to the Zak Net

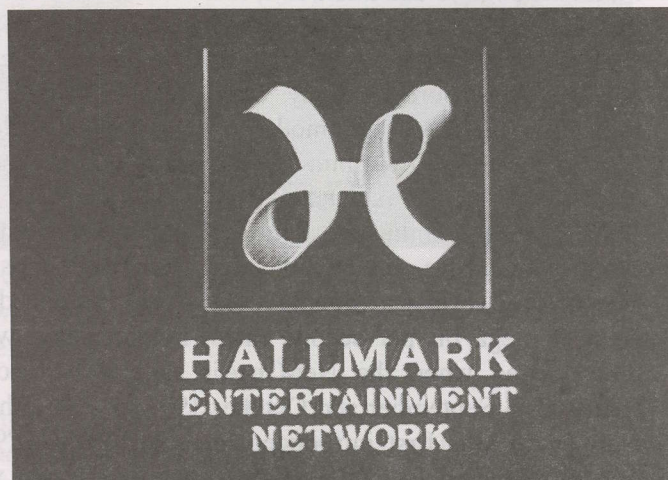

Hallmark (above) is only accessible with Hyundai 2.05 version software while KIBC (below) plays on 2.25 Hyundai and Nokia e3 software.



signal (see Robin Colquhoun's report, p 10 this issue) were made at Subic Bay. From that point onward, people began having better luck (if not totally consistent reception) of Hallmark with DVB receivers. The Nokia e3 (specifically software versions provided by AV-COMM) and Hyundai software version 2.05 (from Skandia) both played the otherwise buried-in-Internet service if you had a reasonably strong signal level. And then Subic Bay modified the data stream, in mid-November.

Observer David Leach (NSW) called first: "*They have added a second programme channel to Hallmark; it says HBO on the menu!*" Yes - it *said* HBO. But there was no data stream there (for example the e3 told you, "No TS" which means no transport stream). It was a book with a cover but nothing inside. Many mistook this to mean the service was encrypted (as well HBO would be). When





**YOU  
SAY  
YOUR  
DISHES  
ARE  
NO LONGER  
PARABOLIC?**

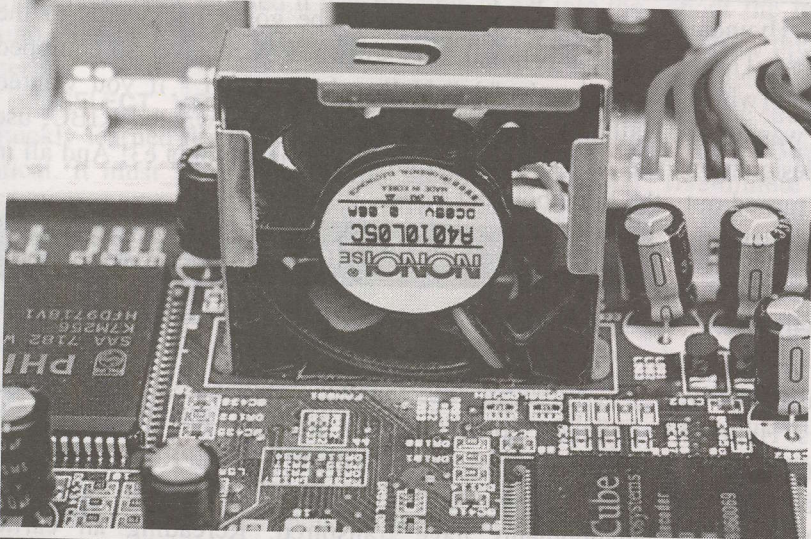

**THE  
FAN  
IN  
YOUR  
HYUNDAI  
IS  
ANNOYING...**



**AND YOUR PICTURES ARE  
CRAP?**

**WE CAN HELP YOU SORT IT OUT.  
SPRSCS '98 • tel 64-9-406-0651 or Fax  
64-9-406-1083**



## Robin Colquhoun Updates Nokia e3 Red Menu Tricks

Those who live by the Nokia Red Menu have learned it is possible to change the receiver's parameters to trick it into developing a reasonably clean NTSC image in a 50 hertz environment. I am aware of various European techniques for accomplishing this but to date have not seen a suggested technique that does not involve unplugging the antenna or switching polarity with the receiver. Here is my suggestion for quicker and more hassle free full screen 60 hertz NTSC display.

- 1) Go to the NTSC channel you wish to watch (EWTN will be my example)
- 2) Once EWTN is "on the screen" (although NOT in the Red Screen menu format), switch to an encrypted service (such as up 3 channels to the encrypted Golf Channel). Because this is encrypted, nothing will appear on the screen (i.e., no signal is being processed).
- 3) Now the "trick" part. While sitting on The Golf Channel, enter the red screen and set it up for NTSC reception (see SF#36/August, p. 11). During this procedure the screen should 'blink' briefly as the synch changes to PAL 60 hertz. The test here is that the screen does not go green or otherwise 'crash.'
- 4) Now by switching back down to EWTN, you will automatically take with you the NTSC (red screen) settings entered for the encrypted/blank service (Golf Channel).
- 5) Then, by switching back to the "blank" programme channel (The Golf Channel in our example) you can use the menu screen in the normal way. For example, you can select the programme channel list, locate a new programme channel to switch to and go directly there.
- 6) This is not possible when you are in red screen and **viewing** a red screen converted NTSC signal because use of **any** key other than channel up and channel down buttons while in red screen and viewing an NTSC service causes the receiver to "crash." (i.e., you cannot select a specific channel and go directly there when in the red screen menu mode).
- 7) If you are in red screen menu and watching a channel, and cannot be certain where the "blank" channel is, use the up or down button to locate a blank channel and once there, push the "OK" button. This will display the channels stored and from this position you can safely select a go-to channel without crashing the e3.
- 8) What this procedure does for you is allow use of the remote control functions without removing the antenna or changing polarity or other tricks.

This addendum note: It is also possible to view non-PowerVu PAL signals while in the 60 hertz mode although the images are slightly exaggerated in height. PowerVu (50 hertz) PAL services such as CCTV also play but will crash after a period of time when operated at 60 hertz PAL red screen menu settings.

"HBO" was added to Hallmark, most of the Hyundai receivers immediately "fell over" on Hallmark. These would be the latest 2.25 versions of the Hyundai (which of course everyone who owned a 2.05 version was quick to switch to). Within a few days, the HBO designation disappeared to be replaced by "KIBC" which turned out to be a new export Filipino service testing (and planning programme launch "before Christmas").

The KIBC test service (mostly static video with various English language audio services) could be received by some (not all) Nokia e3 versions (notably, those from AV-COMM) and also by the latest Hyundai 2.25. But no sign of the original Hallmark (some 2.25 owners reported they could get the audio but not the video). Several enthusiasts attempted to tell their Nokia or Hyundai receivers specific video, audio and synch PID numbers to fix this anomaly.

The "fix" turned out to be going backwards to the Hyundai original 2.05 software. A receiver so equipped would again "do" Hallmark! In short - if you wanted Hallmark, use 2.05 software. If you wanted KIBC, use the 2.25 software or an appropriate Nokia e3! And all in the same bouquet.

### GETTING "INSIDE" The HSS-100C Software

By Stu McLeod, 3 Norrie Place, Tamatea, Napier, New Zealand (fax or telephone 64-6-844-3706)

Since I commented on the "new out of the box via Australia with factory fitted 2.25 EPROM software" (SF#39/November, p. 15), a number of additional developments have transpired. Rereading an earlier SatFACTS (#34/June, p. 12) reminded me that a "hidden menu" can be found if you know where to look. I asked

### INSIDE Hyundai 2.25, Nokia e3 AT SPRSCS '98

Three seminar sessions exploring the technology behind the Hyundai 2.25 (plus 2.05) and Nokia e3 series "consumer level" IRDs are scheduled within the South Pacific Region Satellite and Cable Show February 19 and 20. Hyundai enthusiast **Stu McLeod** will demonstrate "software dumping" from the Hyundai series receivers and explain tricks which enthusiasts can do to make the receiver do things the designers perhaps did not intend to be done. **Robin Colquhoun** will explore the limitations and latest European developed software tricks with the Nokia e3 receivers including demonstrating CAM-equipped models intended for European use only (yes - they do work with Galaxy and other Irdeto CA services).



## WHAT IS KIBC - and Is It For Real?

At a time when most Filipino services are reducing their coverage areas by moving to the Philippines-specific Mabuhay 2 satellite (148E, C and Ku), a group calling itself Kababayan International believes it sees a market opportunity to provide "Filipino Home Service" to countrymen (and women) outside of the country. KIBC-TV and KIBC radio are the result and the service is to be distributed in a free-to-air format using DVB Compliant MPEG-2 over AsiaSat 2 (3940 vertical). The service believes it can create attractive programming to encourage ex-pat Filipinos to invest in equipment to receive the transmissions. KIBC claims to be negotiating "favourable pricing for IRDs and satellite reception equipment" and will supply a list of approved equipment dealers to anyone so requesting. This might be an opportunity for dealers to become a part of a larger distribution and promotion programme; contact "KIBC Distribution Department (Hardware)" at email [kibc@turn-key.com](mailto:kibc@turn-key.com) or fax to ++63-47 252 6145.

The KIBC television programme schedule is available via fax (+ +63-47 252 6145) but is more easily obtained by simply going to Internet and going to Web site <http://kibc.com>. The original plan was to create a 24 hour schedule, 7 days each week. This has been now scaled back to 6 hours of new programming each day, repeated four times daily. Their target audience is spread from New Zealand to UAE, over 9 time zones and it probably makes far more sense to do less programming per day and repeat it - at least in the early stages. English is the primary language and yes - cable TV (and SMATV) operators are being encouraged to carry KIBC-TV as a FTA service (within their Web Site is an invitation page to cable TV operators).

KIBC's latest (to presstime) target date for programming start is December 14th. The Subic Bay uplink reports that Hallmark's supplied receivers (French X-SAT) have experienced no Hallmark/KIBC "problems" since KIBC was added. Additional bouquet programming is possible by February.

Robin Colquhoun to comment on this and he suggested a sequence involving volume and channel buttons during the initial receiver power up. In truth, I found the menu but could not reconstruct what I had done to get there! I then went to Uncle Baysat who located some previously unpublished notes supplied to him as a distributor for the receiver. They advised it was possible to get into the "Auto Search" and "power-up" sequence menu by entering:

**SELECT, VOL DOWN, VOL UP, SELECT**

I quickly learned that the timing of these entries is very critical. It must be entered within seconds of the first TEXT appearing on the screen ("Hyundai, searching channels ..."). If you enter the sequence too early or too late, nothing happens.

At this point you have several menu options including "Standby on, No Auto Channel Search." I suggest that initially this is your choice. Why? When in this master menu selection, the receiver drive functions change radically. In the factory set-up, *you* are a slave to the pre-programming and if the receiver decides to chase its tail searching for a transponder, you are helpless to intervene. In this menu state, you are in charge. This is more like the original 2.05 software except of course with the 2.25, you have more horsepower on the bonnet!

There is more. A third menu!

This menu has testing routines that can be activated. Of note, the 2.05 had similar testing routines but the 2.25 has more routines to play with. Using this sequence a 2.25 software version EPROM can be installed in the receiver, tested and then loaded with the entire Chinese set of SCPC services at the touch of a few buttons. This is significantly faster than loading the various bouquets by hand and I suspect this routine is in the third menu as a labour saving device for the factory set-up personnel.

This third menu is activated at the same critical point in time as the second menu (i.e., during power-up stage) as follows:

(Press) **CHANNEL UP, CHANNEL DOWN, SELECT**

And there is more (no, not another menu - as far as I know ... but). In November SatFACTS I spoke unkindly about the level of fan noise from the HSS-100C (also see p. 2, this issue - ed). I decided to remove the fan and remount it with Velcro insulating pads between the fan and the mounting board. To do this properly, the entire 'Mother Board' must come out and it is not a quickie five-minute job so be warned.

Step one is to disconnect the receiver from the mains. As you may be aware, *switchmode* power supplies are brilliant, efficient and ... the important part ... potentially brutal. While operating, there is a 150 volt DC potential to earth appearing on some of the HSS-100C heatsinks. 150 volts? That is enough to kill you if the conditions are right (or wrong - ed). For the novice tinkerer - it may be tempting to place your finger on a heat sink to determine just how warm it may be. STOP! You may be touching 150 volts. Moreover, even with the power disconnected at the mains, capacitors inside the unit will hold a voltage for some time and you can easily be the unlucky victim of creating an earth path to discharge the capacitors even with the mains disconnected.

With the power disconnected and the receiver "hood up" desolder the frame. Solder wick or braid is best for this because you are dealing with a double sided PC board here. With the fan out, remove the old mounting frame that nests the 5vdc fan. Now reassemble the receiver printed circuit board, attach the fan with Velcro



## UNCLE BAYSAT ASKS ...



**Are your feeds getting too much ground noise, or, too little signal?**

NOBODY would purposefully point their satellite dishes directly into the ground expecting to receive satellite signals! YET - that is what you do if you select the wrong feed for your particular dish. No decision you make concerning packaging a DTH system is more important than the choice of the correct feed for the dish!

A FEED that OVER illuminates your dish might as well be pointing at the ground picking up terrestrial noise! Signal levels may measure good but your signals are buried in noise; not good!

OR, a feed that UNDER illuminates the dish only receives from a portion of the surface, throwing away dBs!

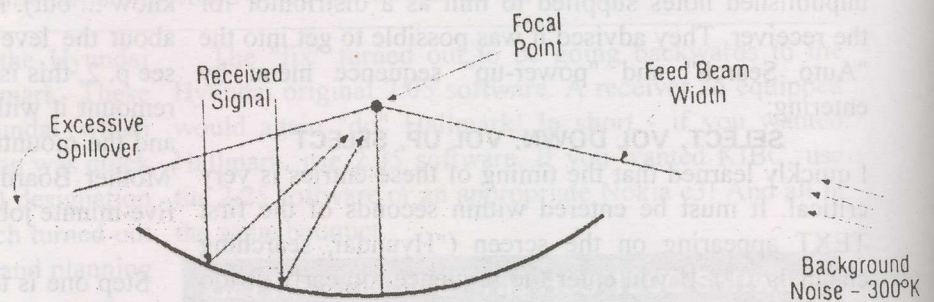

**Don't leave dBs behind at the dish - get all of the signal your system is capable of producing!**

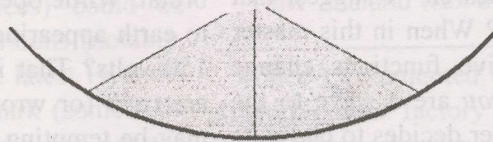

Uncle Baysat recommends and uses for our own installations the versatile ADL range of feeds - there is **ONE** correct feed for every dish installation - ADL makes it and Uncle Baysat has it in stock!

**AND -**

**REMEMBER BaySat is your ONE STOP shop for all Satellite/MATV/SMATV and CATV requirements!**

**BAY SATELLITE TV LTD**

**YES!**

We STILL accept  
VISA, Mastercard with  
no surcharge!

PO BOX 3311 • Napier • New Zealand • Tel toll free 0800-BAYSAT  
International 64-6-843-5296 • Fax 64-6-843-6429 (0800-229-728)

Physical location • 19B Carnegie Road, Onekawa, Napier

<http://www.baysat.co.nz>

e-mail [john@baysat.co.nz](mailto:john@baysat.co.nz)



THE NEXT BEST  
THING TO BEING  
HARD WIRED  
TO THE BIRD...



... The Palcom SL-7900RP  
first choice of satellite  
experts, performance  
conscious installers and  
quality driven consumers  
across the Pacific and Asia.

SL-7900RP: 500 channel memory Hi-Fi Stereo satellite receiver with full motorised actuator dish control built-in. Two IF inputs (950-2050 MHz); Standard 27/18 MHz IF bandwidths, plus 32 step threshold extension for signals as weak as 3dB C/N; Fully tuneable audio sub-carrier range (5.5 - 9.5 MHz) independent on L and R channels; Selectable wide (280kHz) and narrow (150kHz) audio bandwidth with J17, 50uS or Hi-Fi 1600 de-emphasis; Full polarizer control; TV modulator (E21-E69) + 3 SCART 21 pin outputs, separate L and R RCA audio outputs. Every function (including antenna, feed settings) logged into memory for instant recall - totally automatic channel search with companion handheld IR remote. Consistently rated by leading publications "Most versatile, low threshold, ultimate consumer receiver" world-wide. Truly, the next best thing to being hard wired to the satellite.

SL-7900RP from Bay Satellite TV Ltd, P.O. Box 3311, Napier, NZ. Tel 64-6-843-5296 (Fax 64-6-843-6429)

with software by....

**PALCOM**

State of the Art Simplicity



pads and plug in the fly lead. Now you will be "driving" a truly quiet, fan cooled IRD.

### Meanwhile - Inside the Software

Then there is the matter of the RS232 port sitting there on the back apron. It has been bugging me for some time that nothing I could do externally seemed to "turn on" this port. I wondered why. While I had the PC board out for the fan replacement, I studied both sides of the IRD. The RS232 hardware all seemed intact. Perhaps I was not accessing the 232 port because a gate had been left open (no pun intended)?

Connector 102 (marked) is that "gate." I wanted to be able to "watch" the diagnostics within the IRD taking place as the receiver did its thing.

RS232 activity is easily checked by placing an RS232 Mini Tester into the DB 9 Male Port. No activity will be seen on the TX data LED although something obviously is going on inside of the IRD!

Now - if you will move connector jumper 102 to pins 2 and 3 - bingo! Connector 102 is a three pin jumper located on the Main Mother Board just below the (RF/IF) front end PCB. The factory position is indicated by white markings. With the jumper on 2>3, there is now a steady stream of data flowing out of the RS232 back apron connector.

Grab any PC (personal computer), create a cable (DB9 female to DB9 female [2-3, 3-2, 5-5]) and select any communications package ( I initially used Windows 3.1). What follows required five or so hours of experimentation - you benefit from my own mistakes.

- 1) Select 19200 baud rate
- 2) 8 data bits
- 3) 1 stop bit
- 4) no parity
- 5) Flow control = Xon/Xoff

(Note you could use 9600 baud as well but if you do so, change the HSS-100C menu setting to correspond.)

Now - power up the IRD and select the main menu. Go to the bottom and toggle up 19200 baud rate. This done, your PC should instantly begin showing text on the screen. If this is true - try powering down the HSS-100C, clear your (PC) text buffer and then power up again. The full power up sequence will write itself out very rapidly on your PC screen. This appears to be a

```
TP-7 CH_START found...
ver:18, ts[7].PATver:-1
ts[7].PmtArr[1]=5001
ts[7].PmtArr[2]=5002
ts[7].PmtArr[3]=5003
ts[7].PmtArr[4]=5004
ts[7].PmtArr[5]=5005
ts[7].PmtArr[6]=5006
ts[7].PmtArr[7]=5007
ts[7].PmtArr[8]=5008
ts[7].PmtArr[9]=5017<a>
gTrans=7,n=1,ex_id=0x0001
INVALID! VALID VIV_PID[0488] VALID AIA_PID[0460] VALID AIA_PID[0462]<m>
gTrans=7,n=2,ex_id=0x0002
INVALID! VALID VIV_PID[04EC] VALID AIA_PID[04C4] VALID AIA_PID[04C6] unknown
stream type:[80]<m>
gTrans=7,n=3,ex_id=0x0003
INVALID! VALID VIV_PID[0550] VALID AIA_PID[0528] VALID AIA_PID[052A]<m>
gTrans=7,n=4,ex_id=0x0004
INVALID! VALID VIV_PID[05B4] VALID AIA_PID[058C] VALID AIA_PID[058E]<m>
gTrans=7,n=5,ex_id=0x0005
INVALID! VALID VIV_PID[0618] VALID AIA_PID[05F0] VALID AIA_PID[05F2] unknown
stream type:[85]<m>
gTrans=7,n=6,ex_id=0x0006
INVALID! VALID VIV_PID[067C] VALID AIA_PID[0654] VALID AIA_PID[0656]<m>
gTrans=7,n=7,ex_id=0x0007
INVALID! VALID VIV_PID[06E0] VALID AIA_PID[06B8] VALID AIA_PID[06BA]<m>
gTrans=7,n=8,ex_id=0x0008
INVALID! VALID VIV_PID[0744] VALID AIA_PID[071C] VALID AIA_PID[071E]<m>
gTrans=7,n=9,ex_id=0x0011
INVALID! VALID VIV_PID[06E0] VALID AIA_PID[06B8] VALID AIA_PID[06BA]<m>
ver:31, ts[7].SDTver:-1<s>
Data Gol dpid=8192
State change 1 -> 2 NORMAL
video_play/lxLx
CL9100 iniz -> done.
```

Portion of data dump as HSS-100C loads up on California bouquet (PAS-2)

"flight recorder" (a true term, used to indicate the "state flow monitoring system"). This would be absolutely critical for anyone (whether an individual or at the factory) creating software or testing the IRD. Most of the data is straight forward (see example here).

Some observations. I can now see that bouquet surfing is done to a regimen. Quite often (more often than not on *my* dish) the first search "fails" but the second pass through (search) connects ("found"). This seems to be independent of signal level - whether weak or strong. What this data does is expose the tip of the R and D iceberg for further work by independent software writers. Two primary challenges remain:

1) Gaining access to the QPSK "biscuit." such as one has with the Nokia e3 "red menu" (to witness the determination of FEC and Msym rates)

2) Establishing two-way communication with the HSS-100C through the RS232 port. Indeed, this may not be possible as I note that many of the yet not understood IC functions are handled in integrated circuits which are themselves replaceable using extraction methods.

## small, medium and LARGE C and Ku antennas in stock!

Transmit and receive antennas from 1.2m to 13m (Intelsat Standard B). Linear and circular feeds (AsiaSat, Palapa, JcSat, Rimsat, PanAmSat, Intelsat and more) for transmit and receive-only applications. Receive and transmit electronics including inclined orbit tracking equipment with motor drives for elevation and azimuth to 50 tons. Complete system design, fabrication, installation + proof of performance.

P  
A  
C  
I  
F  
I  
C



A  
N  
T  
E  
N  
N  
A  
S

**Pacific Antennas Limited**

Bryon G.G. Evans, PO Box 265, Whangaparaoa, NZ  
Tel/fax 64-9-424-0841 • Mobile 025-789-160



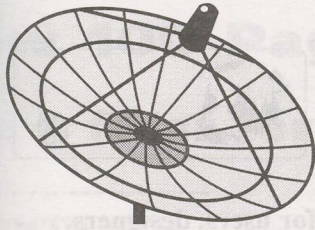

# AV-COMM SATELLITE TV EQUIPMENT

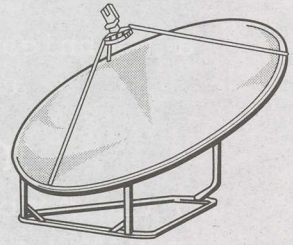

## INTRODUCING THE DYNASAT 300P RECEIVER

\*Plus Australian sales tax if applicable

**ONLY  
\$775\***

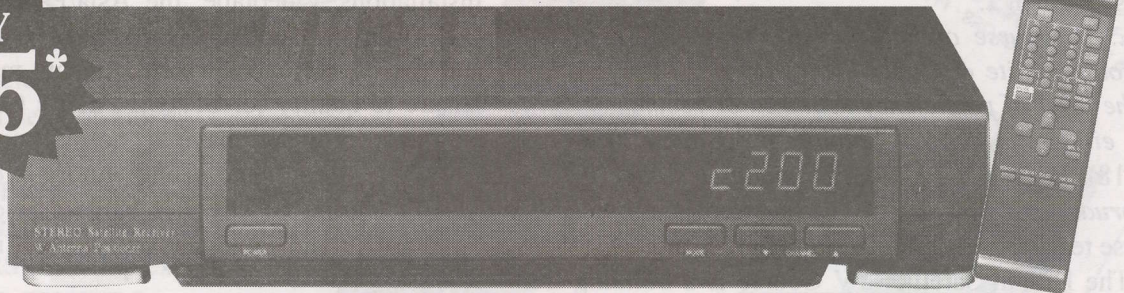

CAT #R1152

## LOW THRESHOLD RECEIVER WITH DUAL AXIS POSITIONER

### FEATURES

- 200 CHANNELS ••▶
- DUAL AXIS POSITIONER ••••▶
- DUAL INPUTS ••••▶
- SCART & RCA OUTPUTS ••▶
- DUAL BANDWIDTHS ••▶
- FREQUENCY SCAN ••••▶
- 14/18V SWITCHING •••▶
- 20 STEP THRESHOLD EXT ••••▶

*\*We reserve the right to improve product performance without notice.*

### BENEFITS

- PRE-PROGRAMMED WITH 90 CHANNELS VIEWABLE FROM AUSTRALIA & 40 FROM NEW ZEALAND.
- FOR INCLINED ORBIT SATELLITES
- ALLOWS DUAL DISH/BAND OPERATION
- MAXIMUM INTERCONNECTION FLEXIBILITY
- SUITABLE FOR HALF TRANSPONDER OPERATION
- SEARCH FOR UNKNOWN FREQUENCIES
- USE DUAL POLARITY OR WIDEBAND LNB
- PRESET THE EXACT THRESHOLD FOR EACH CHANNEL

## AV-COMM PTY. LTD.

DIRECT IMPORTER ACN 002 174 478  
PO BOX 225, BALGOWLAH 2093

TEL: 61 2 9949 7417 9948 2667

FAX: 61 2 9949 7095

VISIT OUR WEB SITE AT

<http://www.avcomm.com.au>

✓YES GARRY, Please send me more info...

Name: \_\_\_\_\_

Address: \_\_\_\_\_

P'code: \_\_\_\_\_

Phone: \_\_\_\_\_



a technical and marketing  
advisory

## memo

to the membership from your  
industry trade association

## SPACE Pacific

Satellite  
Programme  
Access  
CommittEe



**A trade association for users, designers,  
installers, sellers of private satellite-direct  
systems in the Pacific Ocean & Asia Regions**

### Please explain ...

"...the course options for this year's South Pacific Region Satellite & Cable Show Retreat. I am confused by the level of proficiency required or recommended to take either the 'Digital Satellite TV Course' (February 17, 18), or, the 'Satellite Technician Installer Course' (February 21 and 22)." The answer is provided by course teacher and administrator Mark Long.

"The Digital Satellite TV Course is a building from the ground up technical tutorial that first establishes a basic foundation for understanding analogue satellite TV technology and then quickly moves to focus specifically on those areas of digital technology which are of greatest interest and benefit to individuals working in all aspects of the satellite, cable and broadcasting industries.

"The SPACE Pacific Digital Satellite TV Course has been expressly designed to include those students who may not currently have a solid technical background but who wish to understand digital technology and are willing to assimilate knowledge one step at a time. For existing technicians and installers, the two-day Digital Workshop can serve as a basic refresher course. However, any previously qualified people taking this course must be patient to start from the beginning so that ALL students, irrespective of their current level of understanding, can obtain the knowledge they need to advance in the subject. Engineers and rocket scientists need not apply!

"The Digital Course includes a copy of the Digital Satellite TV Installation Handbook, the Satellite

Installations Videotape, the Asia/Pacific Satellites On Disk Library, supplemental course handout materials and the course exam which students may take at their leisure to qualify for SPACE Pacific Certification. The materials provided have a normal cost of US\$450. However, the Mark Long tutorial course through SPACE during SPRSCS is bargain priced at US\$350; February 17 and 18 immediately preceding SPRSCS '98 Retreat.

"The SPACE Pacific Satellite Technician Certification Course (Advanced) has been designed for technically inclined students who require a broad understanding of all aspects of satellite technology. Those who do not have a foundation in basic satellite theory and operation are urged to take the Digital Course first (which fortuitously is conducted first during SPRSCS '98).

"This course covers in great depth the ground and space segments including the uplink (signal origination) aspect of the system. Students are taken a step at a time from programme origination and uplinking through the satellite relay and back down to earth for the variety of on ground receiving systems required. Both analogue and digital are included with emphasis on digital video compression, encryption methods, test equipment use (including the spectrum analyser). The course materials would normally cost US\$450; a copy of the 1997 World Satellite Almanac which retails for US\$197 is also given as a bonus and four course exams are included for post-course self examination and qualification for SPACE certification. The cost is US\$240 and the dates are February 21 and 22."

## MEMBERSHIP IN SPACE

Membership in SPACE Pacific is open to any individual or firm involved in the "satellite-direct" world in the Pacific and Asia regions. There are four levels of membership covering "Individuals," the "Installer/Dealer," the "Cable/SMATV Operator," and the "Importer/Distributor/Programmer."

All levels receive periodic programme and equipment access updates from SPACE, significant discounts on goods and services from many member firms, and major discounts while attending the annual SPRSCS (industry trade show) each year in New Zealand. Members also participate in policy creation forums, have correspondence training courses available. To find out more, contact (fax) 64-9-406-1083 or use information request card, page 34, this issue of SatFACTS. Page space within SatFACTS is donated each month to the trade association without cost by the publisher.



# Year #30\* Filters For Cable TV • TVRO • Interference

## New 100 Page Filter Catalog

Has a filter for every application

- CABLE TV SYSTEMS
- SATELLITE RECEPTION
- OFF AIR INTERFERENCE

### CONTENTS

#### CATV:

- HISTORY
- BANDPASS FILTERS
- CHANNEL DELETION FILTERS:
  - Single channel deletion filters
  - Multiple channel deletion filters
- LOWPASS FILTERS
- HIGHPASS FILTERS
- CHANNEL REPROCESSING NETWORKS
- BANDSPLITTERS (hi/lo diplexers)
- PAY TV TRAPS & FILTERS:
  - History of CATV trapping
- INTERFERENCE SUPPRESSION
- NETWORK PASSIVES
- DROP LINE DEVICES
- WEATHERIZED HOUSINGS

GET IT TODAY!

#### TVRO: FILTERS TO SUPPRESS INTERFERENCE

#### BOOKS: CATV, TVRO, MMDS, INTERFERENCE

- APPENDIX A: INTERNATIONAL CHANNEL FORMATS
- APPENDIX B: INTERNATIONAL CHANNEL FREQUENCIES
- APPENDIX C: ORIGIN OF CATV, TVRO, PAY-TV



## CATALOG CABLE TV INTERNATIONAL/97

More than a catalog of products-  
It's also a tutorial on CATV history and practices.



Emily Bostick  
President

*Emily Bostick*

**\*Emily & Glyn Bostick -  
Continuing a generation  
of personal service to  
TV industries -WORLDWIDE!**



7395 Taft Park Drive  
East Syracuse, NY 13057  
Mailing address:  
PO Box 3307  
Syracuse, NY 13220  
Tel: (315) 452-0709  
Fax: (315) 452-0732  
Canada & US: 800-882-1587

## DISTRIBUTOR INQUIRIES INVITED

Telephone: 315-452-0709

Fax: 315-452-0732 USA

Literature: Ileen Feinberg

Technical: Dave Dann, Tracy Warren, Steve Shafer, Glyn Bostick



# The CABLE Connection

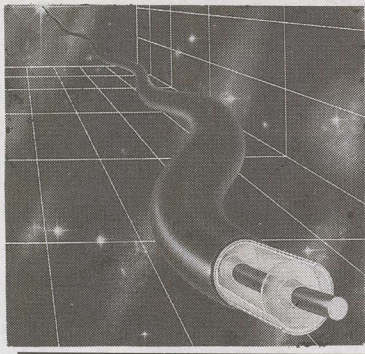

**dBuV versus dBmV**

There are two separate, but comparable, signal voltage (level) measuring systems in use. The dBuV scale is European based and it starts at 0 dBuV which is 1 microvolt. The dBmV is decibels above (greater than) 1 millivolt which places 0 dBmV = to 1 millivolt; the same as 60 dBuV. Therefore 0 dBmV is the same signal voltage as 60 dBuV. Signals lower than 0 dBmV go "minus" such that -20 dBmV is the same as 40 dBuV. 60 dBmV is the same as 120 dBuV; always a 60 dB offset.

## Limitations on Amplification

Selecting an appropriate amplifier for a particular cable distribution system is a challenge. Amplifiers are designed to be cost effective to produce and there is usually an excellent technical reason why two amplifiers - both promising the same amount of "gain" - may have very significant differentials in selling price.

Some of the data sheet specifications are quite clear. For example, the frequency range covered by the amplifier. An antenna mounting masthead amplifier intended to "boost" the signals after they are received by an aerial system might claim 35 dB of gain over a frequency range of 40 to 890 megahertz (MHz). This certainly covers the normal TV terrestrial broadcasting bands (I, II, III-FM, IV and V) and when such amplifiers sell for perhaps \$50 (or less) with their own indoor power supply for cable powering, it seems like a bit of a bargain.

Another data sheet claim that seems understandable is the output level or capability. The same masthead amplifier might claim "115 dBuV" output ability and in comparison shopping, that also sounds like an impressive number. Yet another specification, usually

appearing in large print, which suggests the apparent importance, is "noise figure".

How would a \$50 (trade cost) masthead claiming 115 dBuV "output capability" plus 35 dB "gain" and a 3 dB "noise figure" stack up against a \$600 cable television amplifier claiming 102 dB "output capability" with 28 dB of "gain" and a 7 dB "noise figure?"

Are the cable amplifier people ripping you off when all three numbers clearly seem superior for the inexpensive masthead unit?

The answer is found in an often missing number for the masthead data sheet; the "channel loading" factor. But first a quick explanation of the numbering system. dB is short for decibel and a decibel is a most unusual increment of measurement because it is not always the same. A metre is always a metre, a litre is always a litre. You can define a metre by the number of smaller units (such as millimetres) in a metre; a litre by the number of millilitres contained therein. A decibel cannot be so defined.

A decibel is a *comparison* measurement. Two decibels are never twice one decibel (in fact, twice as much voltage measured in decibels is typically 6 decibels). In our sometimes complex world of signal (voltage) levels,

**Cable, taps, splitters add loss to original amplifier output levels**

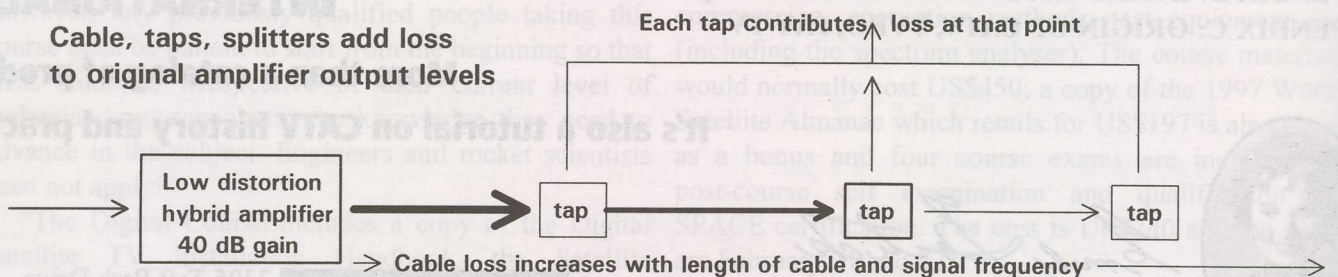

**Output capability of amplifier decreases as a function of number of channels amplified**

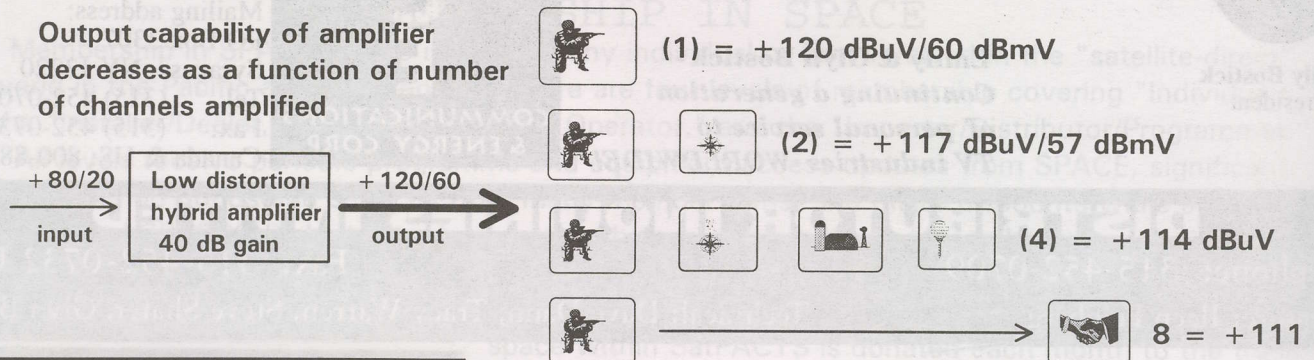



1,000 microvolts (or 1/1000th of a volt) will be either 60 dBuV or 0 dBmV on a signal level meter (see page 22, top right hand box). 2,000 microvolts (2/1000th of a volt) will be 66 dBuV or 6 dBmV. The actual signal "voltage" doubled, the number decibels went up by six. A 10 dB increase in signal voltage is a change from 1,000 microvolts to 3,316 microvolts (1 millivolt to 3.16 millivolts).

A signal amplifier has *gain*, total *output capability* (the sum of all individual signals in millivolts as they appear at the output of the amplifier after amplification), and *noise figure*. A masthead amplifier claiming an output capability of 115 dBuV (same as 55 dBmV) typically means the *sum* of *all* signals amplified must not exceed 562,000 microvolts (56.2 millivolts).

If there is only one TV signal (channel) to be amplified, the claimed 115 dBuV (55 dBmV) output is accurate. However, if there are *two* TV channels to be amplified, the *sum* of the two channels cannot exceed 115 dBuV/55 dBmV. In the decibel world, if both signals were of the same strength at the input to the amplifier and both were amplified by the same number of dB, then the maximum output capability of the amplifier is reduced by 3 dB (from 115 dBuV to 112 dBuV). And if there are four TV channels? A further reduction under the parameters stated by another 3 dB, to 109 dBuV.

The output capability of any amplifier is *shared* by all signals passing through the amplifier and being amplified. If some signals come to the amplifier stronger than others, the division of "output capability" divides between the amplified signals unevenly.

Any amplifier used for TV distribution purposes *should* tell you, up front in the data sheet, the number of separate TV channels that can be amplified at the claimed "output capability rating." If this information is not published, you are only safe when you assume the number applies to a single TV channel only.

By not taking this factor into account, you can end up with some pretty terrible looking TV pictures and scratching your head pondering why. The rule of thumb (which is rough at best) is illustrated on p. 21, lower drawing. Each time the number of channels carried by the amplifier doubles (1>2, 2>4, 4>8, 8>16) the total output *power* dedicated to any single channel must go down by 3 dB.

A cable TV amplifier, designed for 60 channels of service, is therefore 18 dB "derated" from an amplifier that is only one channel rated. Therefore in our example, a cable amplifier claiming a 102 dB output capability for 60 channels is really capable of 102 + 18 or 120 dBuV/60 dBmV for a single channel.

Amplifier selection also involves distortion products which accumulate and grow with each successive amplifier. Distortion that might be tolerated in a single amplifier grows into a significant problem after 10, 20 or 40 amplifiers as we will see next month.

# KONIG ELECTRONIC

## Field Strength Meters

**KONIG ELECTRONIC**

**Combined Field Strength Meter**

**APM 381**

Satellite - Terrestrial - MDS

IDEAL FOR SAT TV - TV & MDS INSTALLERS



SK No. 5785

**KONIG ELECTRONIC**

IDEAL FOR CABLE TV & TV INSTALLERS

**Hand Held Cable & TV Field Strength Analyzer**

**APM 340**

The Field strength analyzer of the future for TV and CATV facilities



SK No. 5777

**KONIG ELECTRONIC**

**Field Strength Meter**

**APM 746 SAT**

Professional multistandard field strength meter for worldwide application

IDEAL FOR ALL PROFESSIONAL INSTALLATIONS



SK No. 5788

For more information on our full range of König Service Instruments & Specifications please contact:- Skandia (61 3) 9819 2466

Distributed in Australia & NZ by

**Skandia**

Skandia Electronics Pty Ltd

Victoria: 183 Burwood Road Hawthorn, Victoria 3122 Australia  
Telephone: (61 3) 9819 2466 Fax: (61 3) 9819 4281  
NSW: Level 1, 39 Terry Street, Rozelle, NSW 2039 Australia  
Telephone: (61 2) 9555 2955 Fax: (61 2) 9555 2455



# SatFACTS Pacific/Asian Region Orbit Watch: 15 December 1997

Copyright 1997: SatFACTS, PO Box 330, Mangonui, Far North, New Zealand (Fax: 64-9-406-1083)

## Analogue Free-to-Air 57E to 80E

Sun Music	57E/703 1395R
RTNC	1352R
Gemini	1220R
AsiaNet	1170R
WorldNet	1095R
NEPC	1085R
TVi	1025R
Muslim	975L
ESPN Feeds	64E/801 1134R
E-TV	1093/L
ViJAY TV	965R
Home TV	68.8/Pas4 Vt1310
ABN	Hz/1365
Sony TV (Hindi)	Hz/1240
Doordar & Iran TV	Vt/1116
CNNI	Hz/1065
TNT/Cart.	Hz/1040
ATN	Hz/995
MTV Asia	Hz/965
Tests	78.5/Th3 Hz/1550
MCOT	Hz/1180
HSTV	Hz/1200
TVT	Vt/1280
Army TV	Vt/1390
RAJ-TV	Vt/1510
UB TV	Vt/1534
Contin.TV	Vt/1565
AsiaNet	Vt/1605
TK Rossija	80/Exprs. 1475RHC
Feeds	1315RHC
VTV4+	1275RHC
ACT/TB3	1225/RHC
TV Center	1025/RHC

## Anal. Free-to-Air 80E to 113E

Russia 3	80/Exprs 1025R
RTR 1	90/S6 1475R
Orbita I	1275R
RTR II	1234R
Orbita II	1215R
VTV	91.5/Me1 Hz/1440
Doordar.1 National	93.5/In2b 1030/Vt
Doordar.1	1160/Hz
Doordar.9	1080/Hz
Doordar.7 Telugu	1070/Vt
Doordar.9 Kanada	1180/Vt
Doordar.1	1268/Vt
Doordar.	1310/Vt
Doordar.3	1348/Vt
Doordar 4	1388/Vt
ORT 1	96.5/S14 1475R
Madagascar	1325R
Tv Azer.	1275R
ERTU Egypt	100.4/As2 1508/Hz
TV Shopping	1490/Vt
Mongolia, Iran/plus	1470/Hz
WorldNet	1265/Hz
CCTV4	1190/Hz
RTPi	1170/Vt
RTR	103/S21 1475R
Vrk/Apt	1275R
CFI	113/C2 990/Hz

Gorizont 30 Mystery  
Gz30, last at 142.5E, reported on move possibly to 121E. Any reports?

## Anal. Free-to-Air 113E to 148E

Brunei, feeds	113/C2 1010/Vt
MTV Asia	1030/Hz
TPI	1070/Hz
TV Indosiar	1090/Vt
ABN	1110/Hz
ANteve	1130/Vt
CNNI	1177/Vt
SCTV	1190/Hz
GMA	1240/Hz
TV3	1250/Vt
ATVI Australia	1270/Hz
TVRI	1310/Hz
RTM	1330/Vt
Gujarat +	1350/Hz
RCTI	1408/Vt
CNBC	1530/Hz
Test Card	128/Jc3 1070Vt
CETV SD	134/Ap1A 1330Hz
CETV2	1250/Vt
CETV1	1170/Vt
CNNI	138/Ap1 1170/Vt
CCTV7	990/Hz
Orbita-I	140/S7 1475R
NTV	1425R
ORT1	145/S16 1475R
RTR Russia	1275R
Test Card	148/Me2 1070/Hz

**For MPEG-2 format digital, see pages 26/27.**

Challenge? Russian MIR downlink analogue FM on 10.830 RHC.

## An. Free-to-Air 150E to 180E

CNBC (inactive)	150/C1 990/Hz
CNNI	169/Pas2 1183/Hz
CNN Feeds	1155/Hz
NHK	1114/Hz
TV Shopping	1400/Hz
Feeds	174/I802 984R
Feeds	973R
Feeds	177/I702 984R
Feeds	963R
Feeds	180/I701 1430R
Feeds	1175R
RFO	1105R
Feeds	1020L

## PALAPA C1 150.5E

CNBC	990Hz
Tests	1030Hz
Tests	1140Hz
Tests	1220Hz
Tests	1330Hz
Tests	1360Hz

Palapa C1 not reported last 30 days

## Encrypted Analogue

Discov. India	68.8/Pas4 1365/Vt
ESPN	1290/Hz
ESPN (d)	113/C2 1030/Hz
HBO Asia (d)	1150/Hz
Discovery (d)	1430/Hz
TNT + (a)	169/Pas2 1218/Vt

## NON MPEG-2 DIGITAL SERVICES

People's Net (GI 1.5)	113/C2 1220/Hz
RPN-9 (SA 1.5)	142/G2 1225L
Fox/Prime (SA 1.5)	169/Pas2/ 1161/Vt
Filipino Channel (GI 1.5)	1060/Hz

(a) B-MAC encrypted, no access available; (c) MPEG encrypted, access may be possible; (d) B-MAC, access for DTH possible some geographic areas.

## DECEMBER ALERT

Watch for announcement December 23-24 of AsiaSat 3 launch. Bird will go to 98E region for test/check out, then move to 105.5E to replace As1 there. ApStar 2R (76.5E) testing now reported finished and commercial service should begin anytime. Last test frequencies included 4100/1050Vt. S-banders should be checking 110E for Cakrawarta 1 tests now. On Agila 1 at approximately 161E check IF 1475 LHC for new Russian commercial feed. And 1180 3780/1370 Msym 26.000, 3/4.



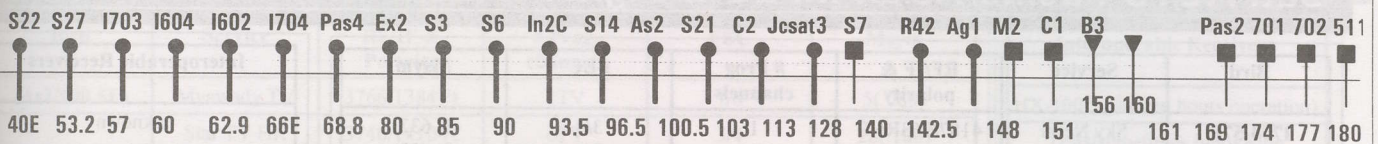

**OPTUS B3  
156E  
(Ku only)**

Aurora	1389/Hz mpeg2
ABC WA	1358/Vt B-Mac
Imparja	1355/Vt B-MAC
Optus test Mpeg2	1328/Vt
GWN	1300/Vt
Net 9, Sky specials	1233/Vt B-Mac
Imparja N.T.	1214/Hz B-MAC
ABC N.T.	1169/Hz B-MAC
Galaxy	1137/Hz Irdeto Mpeg 2
Galaxy	1073/Hz Irdeto Mpeg 2

**Optus A3/152E(a)**

ATN7png	1297/Vt
ATN7png	1430/Vt
a/occasional use	

**Palapa C2 Ku  
(seen South  
equator)/113E**

Test bars	11.148/Vt
-----------	-----------

**MeaSat 2  
148E**

Tests	1070Hz*
-------	---------

\* Colour bars , audio 6.8;  
C-band covers Aust, NZ

**OPTUS B1  
160E  
(Ku only)**

Data	1402/Hz
QSTV	1377/Hz B-Mac
SE ABC HACBSS	1370/Vt B-Mac
SE SBS HACBSS	1344/Vt B-Mac
NE SBS HACBSS	1339/Hz B-Mac
NE ABC HACBSS	1313/Hz B-Mac
Sky Channel	1296/Vt B-Mac
ABC Radio	1276/Hz (digital)
OmniCast	1270/Vt (FM/FM)
ABC feeds	1247/Hz Pal
Sky Nz (sport)	1245/Vt VidCrypt
Net 9 feeds	1220H B-MAC
Sky Nz (Orange)	1218/Vt VidCrypt
Net 10	1182/Vt E-Pal
Net 9	1180/Hz E-Pal
Net 10 feeds	1155/Vt Pal
QTQ9	1145/Vt
Net 7	1120/Vt E-Pal
Net 9 feeds	1091/Vt Pal
Aurora MPEG-2	1076/Hz (tests)
CAA air to ground	1009/Vt Nbfm

**PAS-2  
169E  
(C + Ku)**

CCTV	1433.5/Vt (Sa9223)
Napa feed	1407/Hz
Value Ch.	1400/Vt
Discovery PowerVu	1374/Hz (Sa9223)
Napa feed	1370/Vt
AB Asia, feeds	1335/Vt
Baccarat	1290/Vt
WCE-TV, feeds	1250/Vt
MPEG-2 PowerVu	1249/Hz (Sa9223)
TNT+ (1/2Tr)	1218/Vt B-Mac
CNN+ (1/2Tr)	1183/Hz
FoxSports	1160/Vt (SA 1.5)
Feeds	1150/Hz
NHK	1115/Hz
Feeds	1105/Vt
Napa feed	1065/Vt
ABS/CBN (5 chs)	1064/Hz (GI 1.5)
NBC Mux MPEG	1057Vt (Philips)
MPEG-2 PowerVu HonKong	1002Vt (Sa9223)
TCS Sing.	967/Hz

**PAS-2 Ku**

GWN	12.263V
MediNet	12.286V
Telstra Bendigo	12.300V
Napa TC	12.415V
HiLife	12.582H
MTV Asia	12.604H (MPEG)

**Intelsat 801  
174E**

Feeds	963R
Feeds	984R

**Intelsat 702  
177E**

Feeds	963R
AFRTS	973L (PowVu)
Feeds	984R
Space TV Sys	12.612H (MPEG)

**Intelsat 513  
177W**

Feeds	963
Feeds	984

**(513 Ku)**

Service	RF Freq.
US Nets	10.980V
NBC	11.015V
Feeds	10.510V

**Ku Services**  
Intelsat Ku band services shown here are boresighted to Japan and nearby Asia, have not been reported south of equator.

**TDRS5 / 174.3W**

Fuji TV	1305 Hz
BBC World	1163Hz MPEG

**UPCOMING SATELLITE LAUNCHES**

AsiaSat 3 to 105.5E December 23/24  
(will test near 98E)  
Chinastar 1 to 87.5E February 20

**Intelsat 701  
180E(W)**

TVNZ	955/Dmv 3000
TVNZ	964/Dmv
TVNZ	972/Dmv
TVNZ	980/Dmv
TVNZ	988/Dmv
Occ Vid.	1,020**
TVNZ	1,030
SCPC	1,054 **
RFO Tahiti	1,105
SCPC	1,126
SCPC	1,136
World- net	1,175
Vidiplex	1,220
Feeds	1,254
NHK(e), NBC	1,270
TVNZ	1,344/e
10 Oz MCPC (PwRvu)	1,385
CNN USA	1,430
Baccar.	1,439 **

\* RHC & LHC  
\*\* LHC only  
e/ encryption

**(701 Ku)**

NHK	11.135H
CBS	11.475H
CNN	11.508H



# SatFACTS Pacific/Asian MPEG-2 Digital Watch: 15 December 1997

Bird	Service	RF/IF & polarity	# Prog channels	FEC	Msym	
I703/57E	Sky News	4187/963RHC	1	3/4	5(.632)	
		4140/1010RHC	1	3/4	5(.632)	
I704/66E	CFI	4055/1095 RHC	4	3/4	27(.500)	
PAS4/68.5E	ART/RAI, BBC	3966/1184Vt	2	3/4	5(.632)	
	BBC World	3996/1154Hz	1	3/4	6(.620)	
	Channel 0/TVSN	3743/1407Hz	4	3/4	28(.100)	
	CCTV	3716/1434 Hz	6	3/4	19(.850)	
Thaicom 3 78.5E	UTV	3920/1230 Hz	6TV (#1)	3/4	27(.500)	
	UTV/MCOT	3880/1270 Hz	8TV (#2)	3/4	27(.500)	
Measat 1/91.5	India Bouquet	12284/12346Vt	10+TV?	7/8	30(.000)	
As2/100.5E	European Bouquet	4000/1150 Hz	6TV, 12 radio (#3)	3/4	28(.125)	
	Hubei TV (HBTV Main)	3854/1296 Hz	2	3/4	4(.418)	
	Hunan TV (SRTC)	3847/1303 Hz	1	3/4	4(.418)	
	Guandong TV (GDTV)	3840/1310 Hz	1	3/4	4(.418)	
	Inner Mongolia TV Zizhiqu	3828/1322 Hz	2	3/4	8(.397) (1-China) (2-Mongolia)	
	APTV London	3800/1350 Hz	1	3/4	5(.631)	
	BBC Radio	3793/1357 Hz	?	?	?	
	WTN Jerusalem/London	3790/1360 Hz	1	3/4	5(.631)	
	WTN London	3786/1364 Hz	1	3/4	5(.631)	
	WTN HK	3775/1375 Hz	1	3/4	5(.631)	
	Liaoning TV (Service 2)	3734/1416 Hz	1	3/4	4(.418)	
	Jiangxi TV (JX Sat TV)	3727/1423 Hz	1	3/4	4(.418)	
	Fujian TV (SETV)	3720/1430 Hz	1	3/4	4(.418)	
	Qinghai TV Zenghou	3713/1437 Hz	1	3/4	4(.418)	
	Henan TV Main	3706/1444 Hz	1	3/4	4(.418)	
	As2/100.5E	Sky Racing	4020/1135Vt	3TV	1/2	18(.000)
		EMTV	4006/1144Vt	1TV, 2 radio	3/4	5(.632)
Hallmark/KIBC		3940/1210Vt	2TV	2/3	26(.655)	
STAR TV (Hong Kong)		3900/1250 Vt	5TV (#4)	3/4	28(.100)	
Hei Long Jiang		3834/1316Vt	1TV	3/4	4(.418)	
JSTV		3827/1323Vt	1TV	3/4	4(.418)	
AHTV		3820/1330Vt	1TV	3/4	4(.418)	
"QQQ" China (Shaanxi)		3813/1337 Vt	1, 1 Radio	3/4	4(.418)	
Guangxi GXTV		3806/1345 Vt	1, 1 Radio	3/4	4(.418)	
Rebar TV Taiwan		3785/1365 Vt	5TV (#5)	3/4	18(.000)	

Interoperable Receivers
unknown
N163/17X/2X, HS-100C
e3
DMV, e3
? (MPEG-2, Iredeto)
Pv9223, N163/2X, HS-100C
HS-100C, Philips, probably others (some chs now CA)
HS-100C, Philips, probably others (some chs now CA)
Philips
DMV, HS-100C, Gng, N163, /17X/2X, N2000, P400(b), P500, Pn520/630, Sk888
HS-100C, N163/17X/2X, N2000, Ph3950/11
HS-100C, N163/17X/2X, N2000, Ph3950/11
HS-100C, N163/17X/2X, N2000, Ph3950/11
HS-100C, N163/17X/2X, N2000, Ph3950/11
DMV, HS-100C, N163 /17X/2X
(Comstream ABR200/202)
DMV, HS-100C, N163/17X/ 2X
DMV, HS-100C, N163/17X/ 2X
DMV, HS-100C, N163/173/2X
HS-100C, N163/17X/2X, N2000, Ph3950/11
HS-100C, N163/N17X/2X, N2000, Ph3950/11
HS-100C, N163/17X/2X, N2000, Ph3950/11
HS-100C, N163/17X/2X, N2000, Ph3950/11
HS-100C, N163/17X/2X, N2000, Ph3950/11
Pace DVS-211 (CA)
HS-100C, N163
HS-100C, e3
HS-100C, Pace DVS211(CA), DMV, N163*/17X+/2X
HS-100C, e3
HS-100C, e3
HS-100C, e3
HS-100C, N163/17X/2X, N2000, Ph3950/11
HS-100C, N163/17X/2X, N2000, Ph3950/11
Pv9223 (CA) [Video inverted?]



Bird	Service	RF/IF & Polarity	# Prog. channels	FEC	Msym
(As2/100.5E)	Myawady TV	3766/1384Vt	1TV	7/8	5(.080)
	Star TV HK	3740/1410Vt	6TV	3/4	28(.100)
	STAR TV Hong Kong	3700/1450 Vt	8TV (#6)	3/4	28(.100)
<b>C2/113E</b>	Tests	11.500Hz	multiple TV	7/8	26(850)
	Star Indovision	3500/1650Hz 3580/1570Hz	20 TV (#7)	7/8	26(.850)
	Indovision	3460/1690Hz	6TV	7/8	21(000)
	MegaTV	3780/1370Vt	5TV (#8)	3/4	27(.500)
	Tiernan-I/PTV	3926/3935Hz	1TV	3/4	4(880)
<b>Thaicom 1/120E</b>	Thailand terres.	4120/1030Vt	6TV	2/3	27(.500)
<b>APIA/134E</b>	AXN	4060/1090Vt	4	7/8	28(.330)
<b>API/138E</b>	Reuters	3732/1418Vt	1TV, data	3/4	5(.632)
<b>Palapa C1/150.5</b>	Indovision	4117/1033Hz	10TV	7/8	26(.850)
<b>Optus B3 156E</b>	Galaxy	12.438Hz 12.373Hz	20+TV (#9)	3/4	29(.473)
	Aurora Test	12.564Hz	up to 6TV	2/3	30(.000)
	Optus Vision	12.626 Hz	16TV, 8 radio (#9A)	3/4	29(.473)
(15/11/97)	Austar	12.689Hz	?	?	?
<b>Optus B1 160E</b>	Aurora (MPEG test)	12.377Hz	5+ TV (#10)	2/3	30(.000) [27(.500)]
	ABC Exchange	12.540Hz (.550, .560)	1 each	3/4	6(.980)
<b>PAS-2 169E</b>	Telstra Bendigo	12.300Vt	3TV, 2 radio (#11)	1/2	10(.138)
	Mediasat	12.286Vt	1TV	3/4	6(.610)
	GWN Perth	12.263Vt	2TV, radio	1/2	13(.404)
	MTV Asia	12.605Hz	8TV	1/2	22(.490)
	Hong Kong PowerVu	4148/1002 Vt	8TV (#12)	2/3	24(.430)
	NBC Hong Kong	4093/1057 Vt	7TV (#13)	3/4	29(.473)
	JET Singapore	3962/1188 Vt	2TV (1-Ntsc, 2-Pal)	1/2	13(.740)
	ESPN (USA)	3860/1290Vt	4TV, 2 control	7/8	26(.470)
	CCTV China PoerVu	3716.5/ 1433.5 Vt	5TV (#14)	3/4	19(.850)
	TCS Singapore	4183/967 Hz	2TV (#15)	1/2	6(.620)
	ITJ-Japan	4.174/976 Hz	1 TV	3/4	5(.632)
	AAR-ART/ RAI Int	4153/997 Hz	3TV (#16)	3/4	5(.632)
	PAS-2 feeds	3940/1210 Hz	2TV(NTSC)	2/3	6(.620)
	California PowerVu	3901/1249Hz	8TV (#17)	3/4	30(.800)
	Satcom 1-6	3862/1288Hz	6TV	7/8	19(.465)
	Disney/Aust.	3804/1346Hz	1TV	5/6	21(.093)
	Discovery Singapore	3776/1374 Hz	7TV (#18)	3/4	21(.093)
	Unknown test	3718/1432 Hz	3TV	2/3	6(.620)
<b>1702/177E</b>	AFRTS	4177/973 LHC	8TV, 12 radio & data (#19)	3/4	28(.000)
	SPACE TV Systems	12.612/1312 Hz	7TV, 10 radio (#20)	3/4	26(.694)

Interoperable Receivers
HX-100C (limited hours operation)
Tests/sometimes Indovision
Pace DVS-211 (CA), N163/17X/2X
Pace DVS-211 (CA)
Pace DVS-211 (CA)
Pace DVS-211 (FTA?)
N2X/DVS-211(CA)
N2X (occasional use)
unknown
unknown
N163/17X/2X
same as 3580 C2
Gng. P400, P500, Pn520, + Pn630, Sk888 (e)
e3, HS100C, PV9223
(when testing is over, only IRDs with CAM)
N163/17X/2X, Pv9223, HS-100C
Pv9223, HS-100C, N2X (FTA)
Pv9223, N2X (some Pv CA)
Pv9223, HS100C, e3
Pv9223, HS100C, e3
Unknown- Asia beam only
Pv9223, HS-100C(*), N2X* (some FTA)
HS-100C, Gng, N163/17X/2X, P400 (b), P500, Pn520, Pn630, Sk888
Pv9223 (CA)
Pv9223 (CA)
Pv9223, HS-100C, N163/17X/2X (FTA)
Pv9223, HS-100C N17X/2X (FTA)
HS-100C
HS-100C, Pv9223, N17X/2X, (continues FTA)
Pv9223, N2X, HS-100C
Pv9223, HS-100C (*) N17X/2X (*), (some FTA)
Pv9223 (CA)
Pv9223 (CA)
Pv9223, HS100C, N2X (occasionally Ch. 2 FTA)
e3
Pv9223 (CA)
Pv9223, HS100C, P2X (All now apparently CA)



# SatFACTS MPEG-2 Digital Watch: 15 December 1997 ♦ Support Data

Bird	Service	RF/IF & polar.	# Prog. Chs	FEC	Msym
<b>1701/180E</b>	TVNZ Gennet (feeds)	4195/955RHC	1TV(CA)	3/4	5(.632)
		4186/964	(BBC Gennet)		
		4178/972	1TV(CA)		
		4170/980	(APTV/Tokyo+)		
	Americas	4175/975LHC	3+ radio (?)	3/4	3(.680)
	TVNZ CRY	4120/1030RHC	1TV	3/4	5(.632)
	Canal Plus	4091/1059LHC	1TV (?)	3/4	34(.368)
	Unknown	4088/1062RHC	unknown	3/4	28(.100)
	TVNZTL	3806/1344	MTV Europe	3/4	5(.632)
	10 Australia	3765/1385RHC	6TV	7/8	28(896)

Interoperable Receivers
DMV, HS100C, N17X, 2X, e3 (for non CA channels when active: not all channels active all of the time)
e3, (CA)
(see TVNZ above)
Sagem ISD2050 (?), CA
e3, (CA)
HS100C, e3 (now CA)
Hs100C, e3, Pv9223 (4ch CA)

**Bouquets:** 1) Thailand UTV: (1) CNN, (2) TTV, (3) ESPN, (4) HBO, (5) Ch. 5, (6) itv; 2) Thailand UTV/MCOT: (1) TNT, (2) Star Sport (3) test, (4) TTV News, (5) test, (6) Live, (7) Channel B, (8) Discovery; 3) European Bouquet. (1) Deutsche Welle, (2) MCM, (3) RAI International, (4) RTVE, (5) TV5 Paris, (6) [when operating] Deutsche Welle special programme channel with MediaNet VBI included [lines 10-15, requires DMV M2/Pro/Txt board inserted in 3000 series receiver]; Radio (1) DW#1 (stereo), (2) DW#2 (stereo), (3) DW#3 (stereo), (4) YLE (left) & RCI (right), (5) SRI (l) & WRN (r), (6) REE, (7) DW#1 (stereo), (8) DW#2 (stereo), (9) DW#1 (stereo), (10) NN RA6, (11) NN RA8; 4) STAR TV Hong Kong. (Now all apparently CA) (1) Sky News London, (2) Sports Contribution, (3) Channel [V] International, (4) Star Movies Japan [NTSC], (5) Star Plus Japan [NTSC]; 5) Rebar Taiwan. (1) "U1" [movies], (2) "U2" [news], (3) "U3" [sport, cartoons, general entertainment], (4) "Rock TV", (5) Rock TV [FTA]; 6) STAR TV Hong Kong. (1) Channel 6, (2) ESPN Contributory, (3) Racing Ch., (4) Star Movies SEA, (5) Star Chinese, (6) NBC, (7) CNBC, (8) Sky News, (9) VIVA Cinema; 7) Indovision. (1) HBO Asia, (2) STAR Movies SEA, (3) Film Indonesia, (4) MGM Gold, (5) ESPN Asia, (6) STAR Sport, (8) Channel 'V' International, (9) Channel 'V' Asia, (10) RCTI, (11) STAR +, (12) Discovery, (13) STAR Movies and NBC Asia, (14) Phoenix Chinese, (15) CNN, (16) BBC World, (17) CNBC, (18) Cartoon + TNT, (19) Preview 1, (20) Preview 2; 8) MegaTV. (1) CNNI, (2) Discovery, (3) ESPN Asia, (4) HBO Asia, (5) Cartoon + TNT, [(6) MGM Gold, (7) Cinemax (6-7 may not be operating); 9) Galaxy. Presently 20+ programme channels. 9A) Optus Vision tests of 16 programme channels, programming decisions to be finalised; 10) Aurora. (1) SBS NT, (2) SBS NE, (3) SBS, (4) Sky News, (5) ABC WA; 11) Telstra Bendigo. (1) Imparja, (2) ABC, (3) ABC radio, (4) Imparja radio, (5) ABC TV FTA; 12) Hong Kong PowerVu. (1) CTN 1, (2) CTN II, (3) TVBI Hong Kong, other feeds [NTSC], (4) Ad-hoc 1 PA [PAL], (5) Ad-hoc II [NTSC], (6) ABN, (7) CTN II, (8) CTN; 13) NBC Hong Kong. (1) CNBC, (2) CNBC Mandarin A, (3) NBC Asia, (4) colour bars, occasional feeds, (5) CNBC Mandarin B (6) NBC "2" Asia/Taiwan, (7) Colour bars, "future" use; 14) CCTV China. (1) CCTV4, (2) CCTV3, (3) CCTV9, (4) CCTV4, (5) CCTV5, (6) CCTV8, (7) CCTV tests; 15) TCS Singapore. (1) TCS Test, (2) TCS Default [repeats channel 1]; 16) SCPC3. (1) ad-hoc use, (2) AAR/ART, (3) RAI International; 17) California PowerVu. (1) CMT(NTSC), (2) CBS feeds, others including CTV Canada (NTSC), (3) ATN Asia TV Network(NTSC), (4) EWTN (NTSC) global Catholic radio, ch. 2, (5) BBC World (NTSC), (6) Bloomberg Financial (NTSC), (7) Golf Channel (NTSC), (8) TEST(NTSC); 18) Discovery. (1) Disc. Aust/NZ, (2) Disc. default, (3) Disc. Japan, (4) Disc. SE Asia, (5) Disc. Taiwan, (6) Disc. Philippines, (7) Disc. China; 19) AFRTS. (1) News, Sports [ACII, CW, RR, 9.6 kbps, TV], (2) Spectrum [Urban, 64 kbps], (3) AFN Pacific [TV], (4) Channel 1 - Mirror [TV], (5) AFN Korea [contingency, 1.536, TV], (6) The Jim Lambert Test Channel [!!!], (7) EPG, voiceline, (8) EPG, u/i voiceline, (9) AFN Atlantic [Top 40, HR, NPR, TV], (10) AFN Americas [Top 40, TV], (11) AC1, (12) Country, (13) Adult Rock, (14) NPR [US National Public Radio], (15) Urban, (16) Pure Gold, (17) Top 40, (18) Hard Rock (19) Contingency. 20) SPACE Systems (177E, Ku) claims to be back on the air with 5 CA Taiwan programming sources (see p. 32, here) plus North American sourced adult channels Erotica and Exxtasy. Acer Computer receivers are said to now be available along with one year subscription cards that will function through December 31, 1998.

## MPEG-2 DVB RECEIVERS: [Data here is believed accurate; we assume no responsibility for errors in this volatile area!]

**DMV/NTL 3000.** Skandia Electronics Pty Ltd (tel 61-3-9819-2466)  
**Grundig (Gng) DTR1100** (badged Panasat 630, believed no longer in production). Av-Comm Pty Ltd (tel 61-2-9949-7417)  
**Hyundai-TV/Com.** Model HSS-100C is officially available from Skandia Electronics (tel 61-3-9819-2466), and Bay Satellite TV Ltd (tel 64-6-843-5296). Current version of chips 2.25. Skandia is the master distributor and other sources are reportedly through Asia.  
**Nokia 9500 S (V1.63).** This version is no longer available although it had ability to identify Msym and FEC parameters of unknown carriers. (V1.7X) was a German language "d-Box" version originally imported by OPAC; it functioned with the same parameters as the V1.63. (V2.X; 2.233/e3, 2.034 and others perhaps not yet identified) are current (after June/July) software versions that allow virtually unlimited stacking of bouquets and programmers and for at least the 2.233 version also allows limited red menu correction of NTSC glitch (see SF#36, p. 6). e3 is current Asia-Pacific factory version. Factory supplied sources known include: AV-COMM Pty Ltd (Tel 61-2-9949-7417); SCITEQ (61-8-9306-3738); Telsat (64-6-356-2749). AV-COMM also has macro-command IR remote that expedites 'red menu' operations for e3 version 9500 S. (see SF#36, p. 32).  
**Nokia "d-box"** (V1.7X) suitable for C-band use. Instructions, on-screen prompts may be in German. No longer available.  
**PACE DVS-211.** Officially available only through Sky (racing) Australia (Bob Pankhurst tel 61-2-9451-0888).  
**PACE DGT400.** Through Galaxy offices, Australia.  
**PACE DVR-500.** Bay Satellite TV Ltd. (tel 64-6-843-5296); also supplied by NBC to affiliates.  
**Panasat 520 (Pn520).** OPAC Pty Ltd (tel 61-2-584-1233); no longer available.  
**Panasat 630 (Pn630).** Antares Satellite (61-7-3205-7574); no longer available  
**(Panasat) 642.** A notation - The (642) will not be released except in South Africa and only after start of 1998  
**PowerVu D9223 et al.** Scientific-Atlanta (Sydney) Tel 61-2-9452-3388; BaySat (tel 64-6-843-5296), Telsat (64-6-356-2749)  
**ProSat P-2000.** Not (yet) available as of December 10th. Msym 1-45, no CAM. Antares Electronics Pty Ltd. (tel 61-7-3205-7574)  
**SAGEM ISD2050.** SAGEM SA, Mrs. Salima ALAOUI (tel 33-1 40 70 63 63)  
**Samsung VS-2000 (ver 1.31).** Pacific Satellite (tel 61-7-3344-3883)  
**SK888.** Skandia Electronics Pty Ltd. (tel 61-3-9819-2466)



# WITH THE OBSERVERS

## AT PRESS DEADLINE

### DON'T CALL US -

January 1998 SatFACTS, because of printer holidays, will NOT go into the mails in New Zealand until Monday January 19th. We know this will upset many readers but it is unavoidable. February will return to a normal mailing schedule.

Confusion laced with indecision and corporate business plan failures unfortunately is tainting the Australian domestic satellite world. As reported in some depth in CTD for December 10th, nothing about the present Australian DTH world seems certain at this time. And that includes New Zealand's Sky Network planned digital DBS service as well.

Australia is not alone. Palapa C2 Indovision service, launched early in 1997, has proven to be totally unpopular with even Indonesian viewers and IRD failures in the field are compounding the situation. Further East, Filipino Mabuhay was headlined as the "most powerful satellite in the world" when it launched to 144E. Alas, whether the Filipinos failed to obtain official international approval for 144E or because the bird was in fact "too powerful" at Ku, under intense Japanese pressure they moved it to 148E where it today resides - under



---

Thaicom 3 in Brisbane (Qld) is 4.9 degree elevation angle but with carefully designed system Colin Frost makes it play on Orbitron SX12, PSR-390 receiver and 17 degree Norsat LNB (on screen - Global Thai 5 in test mode).

---

threat of having to be moved even further east (perhaps to near 150E) to escape the on-ground problems its significant dBw levels are creating in Asia. Even tiny EMTV in their switch to PowerVu on AsiaSat 2 has stirred a hornet's nest of complaints. Their coverage is so poor that sizeable (4m+) dishes won't bring it down even in their home country. Not that many terminals in PNG even know this yet - the SA receivers for the service are so back ordered (at 1590 kina) that nobody knows when they will regain EMTV service.

Failures, some total, surround us as we wind up 1997. Perhaps the industry tried to move too fast, to do too many new, unproved and poorly engineered things in the year now passing. Disagree? Hey - have you tried to get service (forget about warranty!) on your Panasat receiver lately?

Palapa C2 Indovision domestic TV service (contains 6 Jakarta based local TV stations) on 3460/1690Hz is VERY loud in New Zealand on modest size (<3m) dishes. Unfortunately the English language Indovision services (3500 and 3580) are not - there at all even on a 5m. (Colquhoun, Fleming and others)



---

**WITH THE OBSERVERS:** Reports of new programmers, changes in established programming sources are encouraged from readers throughout the Pacific and Asian regions. Information shared here is an important tool in our ever expanding satellite TV universe. Photos of yourself, your equipment or off-air photos taken from your TV screen are welcomed. TV screen photos: If PAL or SECAM, set camera to f3.5-f5 at 1/15th second with ASA 100 film; for NTSC, change shutter speed to 1/30th. Use no flash, set camera on tripod or hold steady. Alternately submit any VHS speed, format reception directly to SatFACTS and we will photograph for you. Deadline for January 19th issue: January 7th by mail (use form appearing page 34), or 5PM NZST January 8th if by fax to 64-9-406-1083.





## Distribution Systems

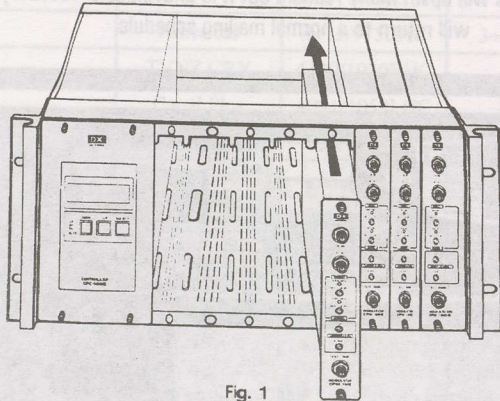

Fig. 1

### Compact Headend CPH-200E

- 8 x VSB Channels in 4RU
- Each one individually controlled
- Agile 47MHz ~ 550MHz
- 250kHz steps
- +45dBmV output

### Modulators

- DSM-140E-Television 45~450MHz
- DSM-155E -Television 470~862MHz
- DSM-190N -Television 47~606MHz with NICAM Audio
- DHM-332EII - FM Stereo 87.5~108MHz

### Splitters & Taps

Wide Band 5~2050MHz

### Analogue Satellite Receivers

Universal Standards Pal/NTSC

#### For further details:-

#### Australia

Peter Pratt

02-9484 3847

02-9875 1563

Phone

Fax

#### New Zealand

Signal Master

09-579 0396

09-579 0386

See us at Sydney's Darling Harbour for  
Australasian Cable & Satellite Exhibition  
February 10-12 1998

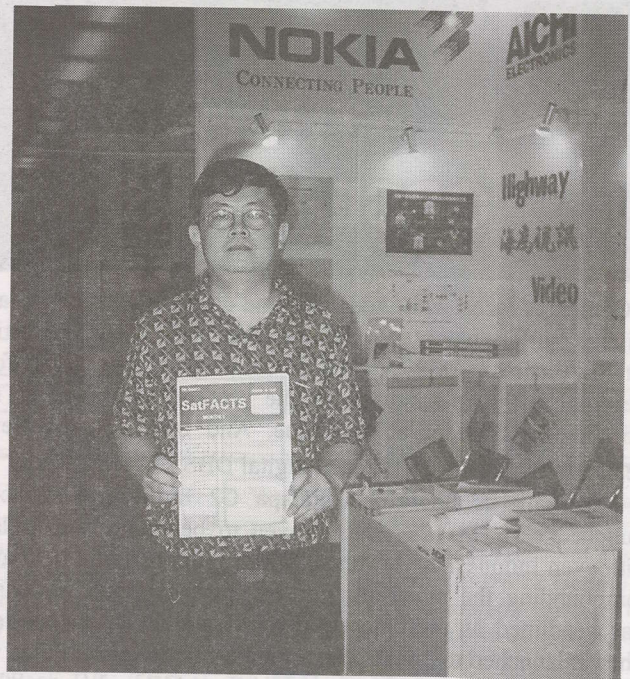

Observer Luo Shi Gang at China CATV Show '97 pauses before Nokia booth to display his favourite reading material. Luo reports ChinaSat 6 is working at 125E with CCTV1 and CCTV2 tests. He also found 177E Ku service from SPACE TV (Taiwan) with HSS-100C (while they were FTA) including Exxtasy channel. Now **that** could be a problem in China! (See At Sign-Off, p. 32)

Will EBB be moving to AsiaSat 3? Unfortunately "no" says Paris based TV5's **Jim Hodgetts**. "The European Bouquet have signed for AsiaSat 2 for five years, the contract is very complicated, and tied to uplink site financing. Moving would be a legal nightmare."

**David Leach** (NSW) reports Palapa C1 (150.5E) now devoid of video; narrowband carriers at 1330, 1360 and 1405Hz.

Thaicom 3 (78.5E) tests reported P5++ by **Alex Zapara** in Waihiki, WA (3608/1542 Hz). Testing now completed; next step - full commercial operation. Just slightly west, ApStar 2R also P5 in WA (4101/1049 Vt). The WA C-band world looks better every day.

Indian Gujarat TV time shares Palapa C2 on 3800/1350Hz with Baztab TV (**Colin Frost**, Brisbane).

Arabsat 1C (37E) sold to Indians as replacement for failed 2D (72.5E); watch for this one to restart soon.

Thai 5 Global Network, composite of Thai terrestrial services, could appear on 177E Ku (as a FTA programme inside of SPACE TV Systems bouquet at 12.612; note - Thai 5 says Msym should [now] be 26.000 whereas previously Space TV was 26.694 so you should check both) and 180E C (3780/1370 RHC possibly with Msym 26.000 and FEC 3/4) shortly, they claim FTA.

Latest Chinese SCPC on As2: JSTV on 3827/1323Vt (standard Msym 4.418, FEC 3/4).

**Chris Maw** would like to work with a group to design an enthusiast's MPEG-2 IRD; contact at 117 Cheyenne St., Sockburn, Christchurch, NZ.

**Steffen Holzt** (New Caledonia) wonders whether any Vietnamese language channels will be available for reception in Pacific on dishes in 3m range. Any help? Steffen also found



Austar B3 testing on 12.689 Hz at level slightly greater than Galaxy.

**Steve Jepson** (Levin, NZ) finds his Sony Trinitron widescreen with PIP (picture in a picture) will separate Vidiplexed services on I180. Set the main channel to a blank video input, activate PIP from satellite feed and you have Vidiplex!

**Gary Stapley** (Christchurch, NZ) has found MediaSat's PAS-2 Vt service (12.286Vt, Msym 6.610, FEC 3/4) including private product and engineering seminars in addition to customised Sky London feed.

**Jim Ruhe**, Honiara (Solomon Islands) reports on his experience with version 2.25 Hyundai chips received through Pacific Satellite. "After installing, I can no longer receive the Hallmark Channel. The title page comes up, then on the next channel up in the bouquet, I can get the audio but no video. I have the same problem with the California PowerVu. The old chips were slow on this bouquet but if I waited it would come in. With the 2.25, nothing - not even a glitch."

Mystery solved: photo (p. 29, November SF) was from Hallmark (as many guessed or knew) and language is Malaysian Bahasa.

Chinastar 1, a Long March launch originally scheduled for 7 December has been delayed to new date of 20 February. The satellite is equipped with 24 each C and Ku, should head for 87.5E.

Russians say they are turning on old RAJ-TV powerhouse global beam transponder on Agila 1 (approximately 161E) to relay Russian language commercial TV programming (3675/1475LHC). **Leon Senior** (Skandia, Melbourne) reports seeing testing December 10th here. This bird is inclined (+/- 1.5 degrees) and will require tracking.

**Distribution centre of DVB MPEG-2 digital receivers for FREE-TO-AIR satellite TV programmes.**

**Wholesale & Retail Welcome**

Consumer grade ---

**HYUNDAI (HSS-100C),  
NOKIA (DVB 9500S),  
PACE (DSR 200)**

Professional grade ---

**DMV (System 3000),  
Hirschmann (DVB7500)  
Philips (DVS 3950/11)**

Satellite IF distribution equipment --

**GLOBAL.**

**Come and visit us if you pass by Hong Kong!**

Hong Kong Satellite TV  
Ltd., Unit C, 7/F, Block  
6, Tien Chu Centre, 74  
Pak Tai St, Tokwawan,  
Kowloon, HONG KONG  
tel: (852)2736-8703  
fax: (852)2735-0583  
email:  
hkstv@netvigator.com

✓ YES, please send me info  
about \_\_\_\_\_ brand  
Company \_\_\_\_\_

Detail address: \_\_\_\_\_

\_\_\_\_\_ p/code \_\_\_\_\_

Tel: \_\_\_\_\_

Fax: \_\_\_\_\_

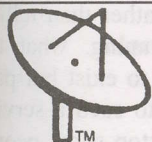

**TELSAT COMMUNICATIONS LTD.™**

TECHNOLOGY IN TOUCH WITH TOMORROW

**RED**

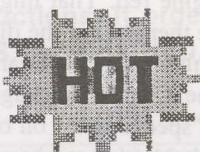

**SEASONS GREETINGS  
CHRISTMAS SPECIALS**



**NOKIA DVB 900S DIGITAL DECODER - \$800 + GST**



**HYUNDAI HSS-100C DIGITAL DECODER - \$995 + GST**

**CYPRESS CDM-600 STANDARDS CONVERTER - \$399 + GST**

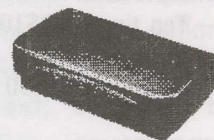

Visit our WEB site at: <http://www.telsat.com>

Our Email address is: [telsat@intec.gen.nz](mailto:telsat@intec.gen.nz)

Contact us for your FREE 24 page catalogue

WHILE STOCKS LAST  
SPECIAL CONDITIONS APPLY



17 Westhaven Grove, P.O. Box 1537, Palmerston North, New Zealand

Tel: (06) 356-2749 Fax (06) 355-2141 Int'l +(64) 6-355-2141 Cellular (021) 454-945

SatFACTS December 1997 • page 31



# AT

## Sign-off

### Shopping For a Christmas Present?

What do you give someone who has virtually every toy known to mankind? How about *two* triple X channels of erogenous adult entertainment that runs non-stop 24 hours each day for a year?

Yes friends, *Space TV Systems is back.*

And they bring with their (now) five Formosa based TV channels a *pair* of North American adult fantasy programme channels which they will give you through December 31, 1998 for the amazing low price of US\$150.

### Tempted?

Here's the skinny. Space TV Systems has had its problems as every adult reader of SatFACTS is aware. First they appeared on Intelsat 702 Ku at 177E back in May with as many as eight Formosa based TV channels. Soon after they began this "test" they added a pair of North American based adult channels, triple X (as in "XXX") at that. And the excrement hit the fan (along with several other categories of body fluids). SatFACTS first reported on this amazing odyssey in our July 15th edition, detailing the technical and operational challenges facing the Taiwan based firm. In our August issue, we reported Exxtasy's top executives (Stuart Duncan and Fred Pantalone) had visited Australia and New Zealand to round up support for their new "*slightly* left of centre" programming. In our September issue we reported satellite host Space TV Systems had run into some "operational problems" which by October had grown into an ugly international 'affair.'

*And now they are back.* When Space TV Systems first tried to 'sell' their service to Australian distributors in June, the price was more than US\$80,000 for a 'distributorship.' By August the price had dropped in half but was still a healthy 5 figures and nobody rushed to take them up on their offer.

Price has now come down. It may even be a good deal as presently offered; certainly as an adult business person you are better equipped to make that decision that I. So I'll just tell you what they are floating and you be the judge.

First, you send them US\$7,000. That gets you ten (10) of their Acer Computer manufactured MPEG-2/DVB IRDs equipped with smart card (French Access) control.

Next, you send them one of the following:

Ten times US\$100 for ten Space TV Chinese Package smart cards, or,

Ten times US\$150 for ten Exxtasy Package smart cards, or,

Some combination of the two that totals ten (10) cards.

The programming you will access with the Chinese Package cards will be (1) Formosa TV News, (2) Formosa TV International, (3) Space TV Music Channel, (4) Space TV Lifestyle Channel, and (5) TV5. Which TV5 that might be we have no idea. That it might be the EBB's French TV5 seems to us very unlikely.

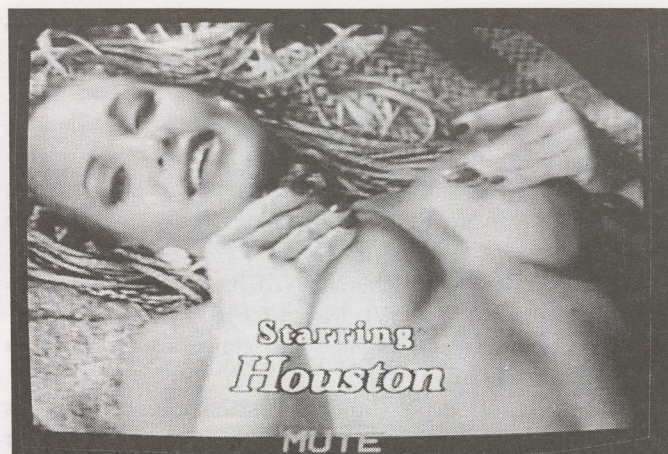

Now if you have no Taiwan homeland clients but you do have some horny guys and gals who want to watch other people play sex games on (in, under, along side) the tube - then the Exxtasy Package will perhaps be a better income producer for your business. US\$150 gets you 24 hours per day of the most outrageous of them all - Exxtasy (above), and, the even more outrageous "Erotica," also 24 hours of non-stop fore (aft, starboard and port) play.

New Zealand's Parliament recently heard a recommendation that while cable cannot distribute the likes of either Erotica or Exxtasy, "*nothing in the (new) law will prevent individual homes from installing a satellite dish, paying for and tuning in such services that originate outside of New Zealand.*" That's the good news (the bad news is it takes a 3m and up size dish to access the Space bouquet in the land of the long white cloud).

Out in New Caledonia, Steffen Holzt reports a dish in the 2.4m range will do. Meanwhile over along the eastern seaboard of Australia, a 1m dish seems reasonable and some are claiming 75cm is *big* enough. Perhaps rather than telling people they cannot pay for adult programming, what the politicians should do is allow these services to exist but pass legislation that requires anyone subscribing to such a service paint their dish fire engine red. That might stop some people from doing it - or cause them to put the dish in their front yard where it would not be missed as a landmark!

That US\$100 for the Chinese Package and \$150 for the Exxtasy Package is a "special deal" on offer from Space TV. The offer expires March 31 (they say) and the cards will play the chosen package until midnight December 31, 1998. The IRDs will be shipped from Taiwan (plus freight) and they say it will take ten days from the time you wire transfer your payment before you receive the cards and IRDs. The offer is good to anyone in Taiwan, China, Korea, Japan, Australia, the US and Canada. That they would turn down an order from New Caledonia, New Zealand or Thailand is very unlikely.

So there you have it; the perfect Christmas gift for someone who has every known toy. With two adult channels, a fella or gal really needs two IRDs and two Access cards so both channels can be watched simultaneously. Sort of like stereophonic audio, only in video. Imagine locking a *normal* person in a room with two TV sets tuned to these two channels, the controls out of reach, the sound at adulterous ear shattering levels and not a stick of furniture in the room. Only a wall to wall mattress. Could this be the fabled Chinese water torture ejaculated into the 21st century?

Good grief. **Don't call us** - contact James Tzeng at Space TV Systems, Inc., 3 Pointo Drive, Suite 118, Brea, California 92812; tel ++-1-714-529-9988; fax ++-1-714-529-9989.



## THE 1998 SATELLITE EXPLOSION IN THE PACIFIC/ASIA!

**AsiaSat 3 is on the way (testing near 98E, then to 105.5E for operation) and that is but the beginning of the busiest year to date in Asia - Pacific satellites!**

**Stay tuned with SatFACTS!**

- ENTER my 12 MONTH subscription to SatFACTS starting with January 15th issue (rates below)  
 ENTER my 36 MONTH subscription to SatFACTS starting with January 15th issue (rates below)

NAME \_\_\_\_\_

Company (if applicable) \_\_\_\_\_

Mailing address \_\_\_\_\_

Town/city \_\_\_\_\_ Country \_\_\_\_\_

**Amount to send:** 1 year - NZ\$50 (inside New Zealand) / A\$90 (inside Australia) / US\$60 (outside of NZ and Australia) or 3 years - NZ\$120 / A\$210 / US\$150 if by cheque. **VISA** or **Mastercard**? See form below and return with order. Return to: **SatFACTS, PO Box 330, Mangonui, Far North, New Zealand** or if by VISA or Mastercard fax to 64-9-406-1083

**ALL SatFACTS SUBSCRIPTIONS ARE SENT VIA AIRMAIL - WORLD-WIDE!**

USE THIS FORM ONLY WHEN CHARGING ON VISA/MASTERCARD

Please charge my **VISA/Mastercard** as follows:

- ONE Year of SatFACTS MONTHLY (NZ\$50, A\$90, US\$60)  
 THREE Years of SatFACTS MONTHLY (NZ\$120, A\$210, US\$150)  
 SATELLITE TELEVISION: The Booklet (NZ\$10, A\$12, US\$10)  
 One Year of COOP'S TECHNOLOGY DIGEST (NZ\$125, A\$125, US\$125)

Indicate charge card type:  VISA  Mastercard

Name (as it appears on **VISA / Mastercard**) \_\_\_\_\_

**VISA/Mastercard** Number \_\_\_\_\_

**VISA/Mastercard** expiration date \_\_\_\_\_

**Instructions:** If ordering by mail, return this complete (3-part) card or a copy of same (to **SatFACTS, PO Box 330, Mangonui, Far North, New Zealand**); if order by FAX, send full card as a single sheet to **64-9-406-1083**

### SUPPLEMENTAL MATERIALS from SatFACTS MONTHLY: Order Form

- SATELLITE TELEVISION:** The Booklet. Excellent introduction to home dish ownership for the layman, including major contributions from the father of geostationary satellites - famed science fiction writer *Arthur C. Clarke*. The perfect tool to help the satellite system seller explain home satellite TV to the layman consumer. From SPACE Pacific. NZ\$10 / A\$12 / US\$10, airmail.
- COOP'S TECHNOLOGY DIGEST.** For the really serious enthusiast, investor, business person in satellite television and allied leading edge technologies. Ten issues each year, jam-packed with information you will not find anyplace else. "Coop" routinely culls more than 60 publications world-wide, terribly expensive newsletters, Internet and his hundreds of private contacts to keep you right at the leading edge of technology on the **REAL** changes underway in telecommunications. Conveniently issued near the **first of the month**, creating an excellent time-line-filler between the mid-month issues of SatFACTS. Now in the 5th year, airmail world-wide. Normally NZ/A/US\$250 per year - for SatFACTS subscribers special **50% discounted** price of NZ/A/US\$125.



## OBSERVER REPORTING FORM - CONTEST ENTRY - Due Jan 5

- NEW programming sources seen since Dec 1st: \_\_\_\_\_
- Changes (signal level, transponder, programming content) in pre-existing programming sources since Dec 1st: \_\_\_\_\_
- OTHER (including changes in your receiving system): \_\_\_\_\_

NOTE: Please use P1 - P5 code when describing signal levels and receiver IF/RF settings.

Your Name \_\_\_\_\_ Is this contest entry? \_\_\_\_\_  
Town/City \_\_\_\_\_  
Make/size dish \_\_\_\_\_ LNB \_\_\_\_\_ Receiver \_\_\_\_\_  
Bonus Word Entry: \_\_\_\_\_ on page \_\_\_\_\_

November bonus word - *nipplewort*, p. 2

MAIL TO: SatFACTS Monthly, PO Box 330, Mangonui, Far North, NZ or fax 64-9-406-1083

### YOU COULD WIN A PALCOM SL7900RP!

SatFACTS is giving away the top of the line super receiver - the PALCOM SL 7900RP - to a subscriber in February! This is a MONTHLY CONTEST and you must REGISTER with us as a contest entrant. Complete this card to receive the full set of Contest Rules and join the fun. A DYNASAT 300P was given away October 5th - a new PALCOM SL 7900RP given away February 5th!



I AM A SUBSCRIBER TO SATFACTS - Please mail to me my SatFACTS Reader Contest Rules!

NAME \_\_\_\_\_  
Company (if applicable) \_\_\_\_\_  
Mailing address \_\_\_\_\_  
Town/City \_\_\_\_\_

Return card to: **SatFACTS Monthly**, PO Box 330, Mangonui, Far North, New Zealand  
of fax to us at 64-9-406-1083

### SPRSCS '98 INFO PACK?

FULL INFORMATION PACKET DESCRIBING THE FEBRUARY 17-22  
South Pacific Region Satellite & Cable Show - **Hurry** - time is  
running out!

YES - Send details of SPRSCS '98 to ...

NAME \_\_\_\_\_

Company (if applicable) \_\_\_\_\_

Mailing address \_\_\_\_\_

Town/city \_\_\_\_\_

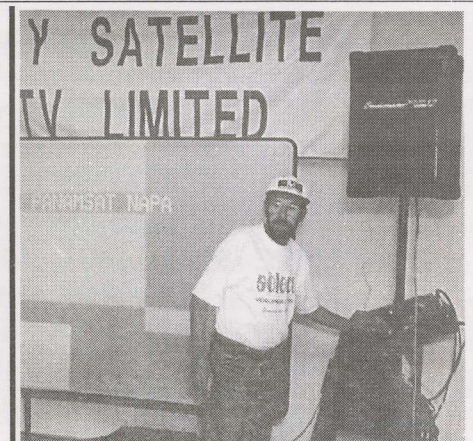

**SPACE Pacific Ltd.**  
PO Box 30, Mangonui, Far North  
New Zealand  
Fax 64-9-406-1083



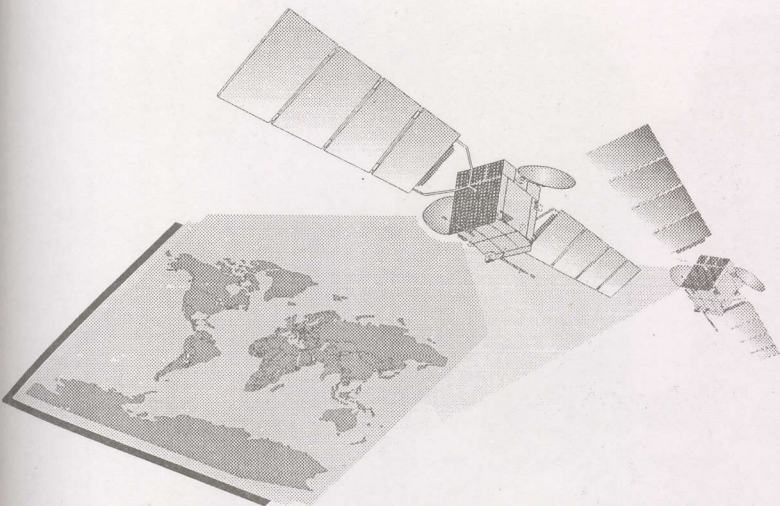

Full colour footprint maps, frequency plans, spacecraft illustrations, program listings and contact information with supporting charts and software manual for the region's present and future telecom satellites.



**The Perfect Christmas gift to give yourself!**

***New from Mark Long, Founding Publisher of the World Satellite Almanac***

It used to be that anyone needing access to technical information on telecommunication satellites had to wade through high-priced reference books containing hundreds of pages of text and technical drawings. Even then, the information in these vast tomes was out of date by the time the reader actually received it. The Asia/Pacific **SATELLITES ON DISK LIBRARY** allows you to access comprehensive, up-to-date technical information on Asia/Pacific satellites directly from your personal computer. What's more, you can quickly locate the graphic or text-based information you need, import it into your favourite word processing and page layout programs, and then print your own in-house reports, marketing studies, advertisements, customer proposals, and training materials. Best of all, you don't have to wait for anyone to print the next annual installment of their pre-historic paper publications because the **SATELLITES ON DISK LIBRARY** includes a software upgrade option which will allow you to download the latest updates from our Internet corporate site on the Worldwide Web.

*"Save a tree and get the satellite information you need, electronically."*

**The Asia/Pacific Edition of SATELLITES ON DISK LIBRARY:**

- 150 full-colour satellite footprint maps
- dozens of satellite line drawings
- text-based technical descriptions
- regional satellite summary charts
- transponder plans & activity charts
- other essential reference materials
  
- Runs on IBM PC compatible computers running Windows 95 or System 7.5 on Power Macintoshes. Use Internet Explorer or Netscape Navigator to to fully explore all hypertext links.
- Software manual with summaries of what's available on disk.

**Asia/Pacific SATELLITES ON DISK LIBRARY**

US\$ 95 plus \$15 shipping & handling. All checks must be in US dollars drawn on a US bank and made payable to MLE INC. Fax credit card orders or mail form together with payment to:

**MLE INC.**, P. O. Box 159, Winter Beach, Florida 32971 USA  
 124 Chang-klan Rd #110, Chiang Mai 50100 Thailand  
**Fax (USA):** 951-764-1722 **Fax (Thailand):** 66-53-818-435  
**E-mail:** mlesat@cm.ksc.co.th **Web site:** http://www.mlesat.com

Name: \_\_\_\_\_  
 Company: \_\_\_\_\_  
 Address: \_\_\_\_\_  
 City: \_\_\_\_\_ State: \_\_\_\_\_  
 Zip: \_\_\_\_\_ Country: \_\_\_\_\_  
 Tel: \_\_\_\_\_ Fax: \_\_\_\_\_  
 MC/Visa: # \_\_\_\_\_  
 Exp. Date: \_\_\_\_\_ Signature: \_\_\_\_\_



**"After extensive testing of competitive products, we have found the PDX MTA series 550 MHz trunks and LN series line extenders significantly better suited to South Pacific operating conditions than any other similar equipment currently available."**

Doubtless Bay Cable TV, New Zealand

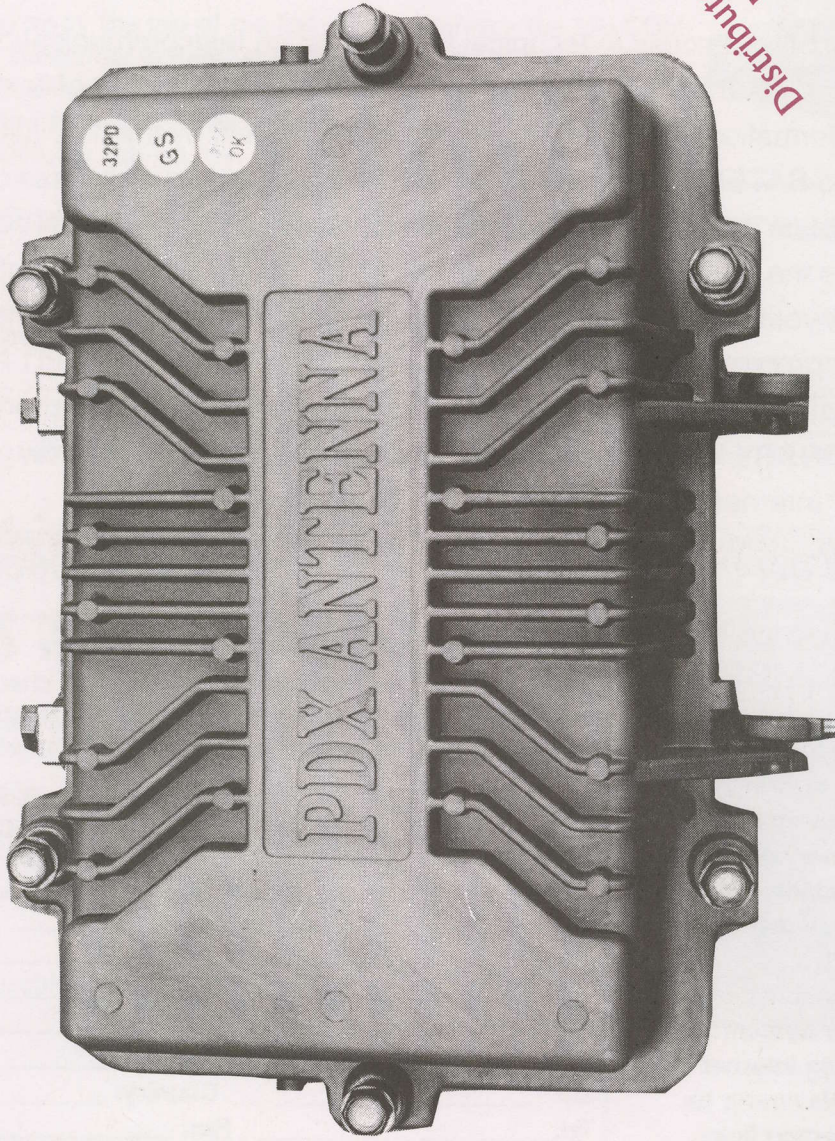

*Distributor Enquiries Invited!*

**MTA-550N/GS Trunk Series design choices:** Push-pull or power doubling ■ 54-550 MHz bandwidth forward (54-750 MHz modules available) ■ 5-30MHz reverse bandwidth with built-in duplex filter ■ 28 dB gain in manual operation, 32 dB gain in automatic (AGC/ASC) ■ Built-in -20dB input & output directional coupler test points ■ Plug-in automatic control module for slope and gain (uses system carriers at bottom and top end of bandwidth as references) ■ Exceptional heat dissipation, RFI integrity, moisture sealing against ingress/egress ■ 35-75VAC line power operation with switching regulated power supply ■ State of the art cascadeability for long unattended trunk runs ■ Cost effective for low density cable plants, strand or pedestal mounting ■ Automatic transient, over voltage protection with current limiting for reliable operation

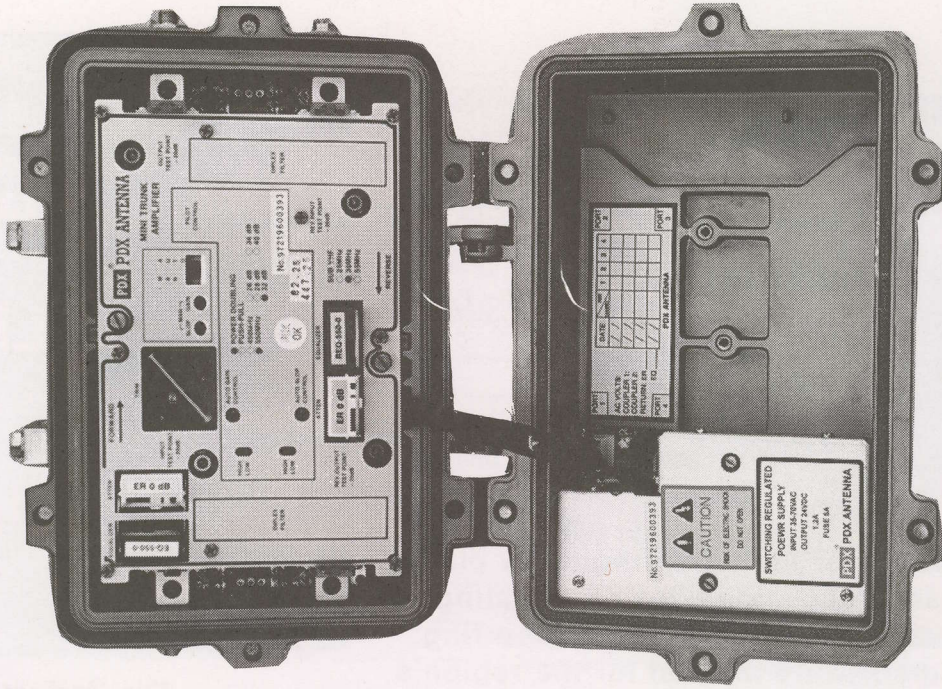

Model MTA-550GS/32D power doubling trunk (66 PAL format cable channels simultaneously)

**PDX ANTENNA MASTER CO., LTD.**

Mr. Peter Lin • 76, Sec. 2, Pei Shin Road, Tansui Town, Taipei Hsien Taiwan, R.O.C.  
Telephone 886-2-621-9600 • Fax 886-2-622-7157