

14-10-97 - 9am

Corrections

Bob Cooper's

OCTOBER 15 1997

SatFACTS

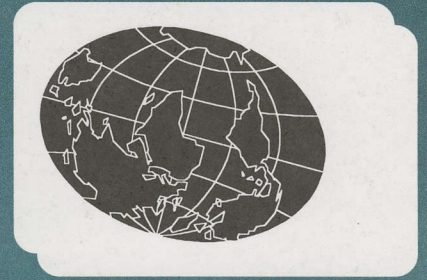

MONTHLY

Reporting on "The World" of satellite television in the Pacific and Asia

IN THIS ISSUE

**INSTALLING A
24 FOOTER
IN THE MARSHALLS**

**NEW SATELLITES
SCHEDULED FOR
THE PACIFIC/ASIA**

**DIGITAL UPDATE:
Good News for
Hyundai Fans**

- ✓ Latest Programmer News
- ✓ Latest Hardware News
- ✓ Latest SPACE Pacific Reports
- ✓ Cable TV Connection

Vol. 4 ♦ No. 38

Price Per Copy:
NZ\$8/A\$9/US\$6



Paraclipse[®]

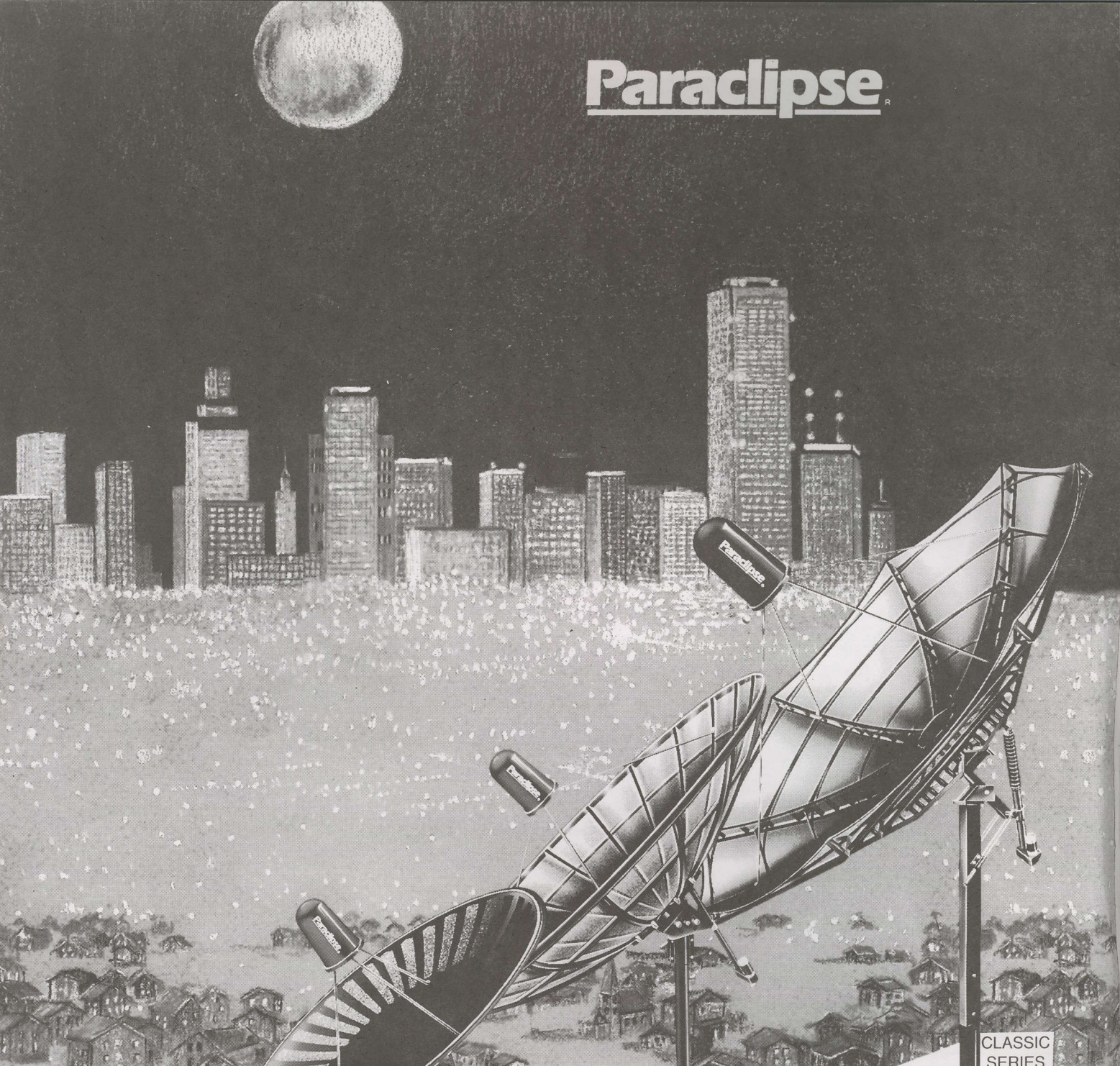

CLASSIC
SERIES

ECLIPSE
SERIES

HYDRO
SERIES

When quality, strength, and accuracy are your main requirements, **Paraclipse** antennas are your first choice.

Only **Paraclipse** offers such variety; four distinctly different series: the Truss-Ribbed Classic, the Courier Deliverable Eclipse, the Stretch Formed Hydro, the Commercial Patriot.

Every **Paraclipse** model sets the industry standard in its class, worldwide.

Distributed in Australia by
SKANDIA ELECTRONICS Pty. Ltd.
183 Burwood Rd, Hawthorn, Melbourne
Tel 61-3-9819-2466 * Fax 61-3-9819-4281
Level 1, 39 Terry St, Rozelle, Sydney
Tel 61-2-9555-2955 * Fax 61-2-9555-2455

Distributed in New Zealand by
BAY SATELLITE TV Ltd.
PO Box 3311, Napier
Tel 64-6-843-5296 Fax 64-6-843-6429

Paraclipse[®]

HIGH PERFORMANCE ANTENNAS

Paraclipse Inc.
2271 29th Avenue East, Columbus, Nebraska USA 68601
Telephone: (402) 563-3625 Fax: (402) 564-2109

★ MADE IN AMERICA

Digital FTA
Digital + CAM
Analogue FTA
Analogue MAC
60/65/72/85/90/
99/100/140cm
Quatro LNBs
ACUs
Cable Kits
Memory Cards
Mounting Kits
and more!

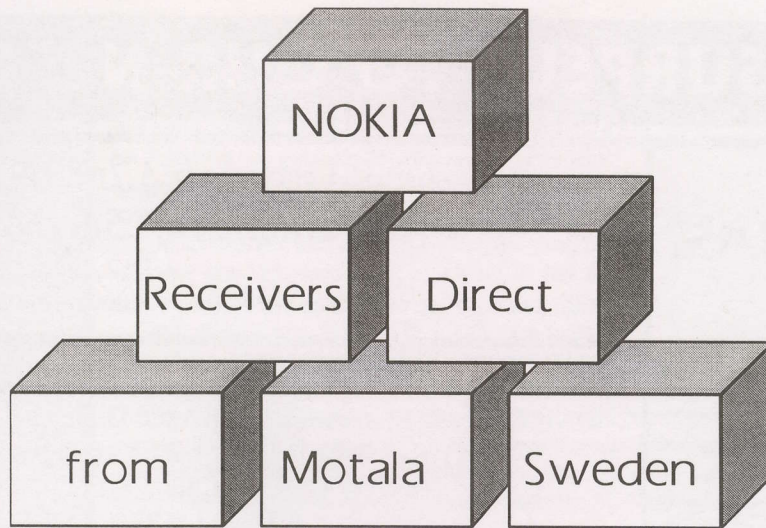

THE
FINEST
OF
FULL
LINE
NOKIA
PRODUCTS
FROM
A
MOTALA
SOURCE!

IN STOCK - IMMEDIATE AIR SHIPMENT WORLD-WIDE

Nokia 9500S FTA / Latest Factory Software!
Nokia 9200S European FTA / Latest Factory Software!
Nokia 9200S + CAM IRDETO / Latest Factory Software!

MOTALA DIRECT DISTRIBUTOR - SWEDISH FACTORY SUPPORT TO DISTRIBUTORS
AND DEALERS - Call, fax or email for current MOTALA-DIRECT price list

Jacobson's

Thore Jacobsson • Nedralid S., 591 97 Motala, Sweden
Phone +46-141-220-331 • Fax +46-141-220-111 • GSM +46-706-
010-331 • GSM FAX +46-706-120-331 • e-mail jacobsons@swipnet.se

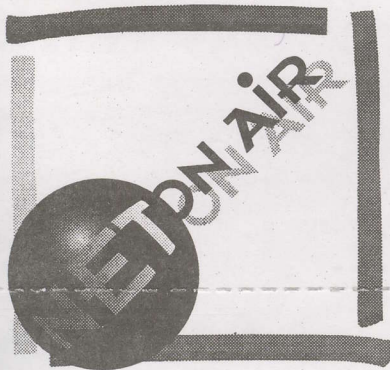

OUTSTANDING INVESTMENT OPPORTUNITY

Be part of the Internet Information explosion!

Revolutionary Technology

NET ON AIR ASIA PACIFIC Pty Ltd is a Queensland, Australia based Multimedia Technology company that has recently secured the rights, in 30 Pacific rim countries, to the world's first Internet TV broadcasting technology... A concept that is set to revolutionise the multi million dollar internet industry. Satellite delivery on (DW TV) (VBI) on ASIA SAT 2.

Investing in 30 countries

Currently Net On Air is offering potential investors the opportunity to purchase Multimedia Management Rights in the following countries: Australia, New Zealand, Sri Lanka, Cambodia, India, Hong Kong, Singapore, Vietnam, Laos,

Thailand, Burma, Brunei, Tahiti, Vanuatu, Philippines, Indonesia, Papua New Guinea, Fiji, New Caladonia, Solomon Islands, Cook Islands, Marshall Islands, Butan, North Korea, South Korea, Taiwan, Nepal, China and Canada.

The Rights include:

- Exclusive Territory
- Once Only Management Rights Fee
- Full Advertising Support
- Total Operations and Training Support
- High Profit from sales
- Secure Ongoing Income
- Worldwide Leading Edge Technology
- Possible Bonus Share Option in the Parent Company

If you are interested in entering an exciting new, lucrative, high growth industry with a company at the forefront of multimedia technology, then contact Mr Peter Fischer or Mr Barry Taylor at **NET ON AIR** for an information pack.



Makes the Internet as easy as watching TV!

NET ON AIR ASIA PACIFIC Pty Ltd
2/61 Lawrence Drive
Nerang, Queensland
4211 Australia

Telephone: 61 7 5596 0962
Facsimile: 61 7 5596 0728

SURPLUS TO OUR NEEDS

ANTENNAS

ONE Orbitron 3.7m (NZ\$500)
ONE Paraclipse 4.5m (NZ\$1,500)

(Both antennas are assembled but stored face down after being removed from service)

MPEG RECEIVERS

ONE General Instrument DSR 1500 Digicipher + analogue (NZ\$2,000)
TWO S-A 9708 B-MAC + FTA analogue (NZ\$1,300 each)
ONE NTL/DVM 3000 MPEG-2 (NZ\$2,500)
ONE S-A D9222 MPEG 1.5 (NZ\$1,000)

(All receivers with manuals, operational as removed from service)

CABLE TV EQUIPMENT

CATV Set-top converters: Approximately 50 (mixed Winersat WTC-301, PX EC-60R) - all tune 48 to 550 MHz with IF output 55.25 MHz. 25 new in boxes, 25 new as tested or removed from service, all with remotes and functional. As a lot - NZ\$2,000. Ten (10) CATV grade adjacent channel stackable rack mount modulators, 115 dBmV output, various channels 48.25 to 217.25, excellent quality - all new, unused - NZ\$250 each. 2X and 4X directional taps from 4T to 32 dB isolation, standard 5/8ths entry; enquire.

FAR NORTH
CABLE TV LTD

PO Box 30, Mangonui, Far North
New Zealand
Tel 64-9-406-0651 ○ Fax 64-9-406-1083



INTERNET TECHNOLOGY INVESTERS WANTED

Secure your exclusive rights to the worlds first Internet Television Broadcasting Technology in one of 30 countries! *Call for details.*

NET ON AIR ASIA PACIFIC

NOW IN AUSTRALIA!

Introducing the multifunctional Decoder that relays multimedia Teletext and 1000's of Internet highlights into your home, without using a phone modem!

It makes the Internet as easy as watching TV!

What You Need

to plug into NET ON AIR

- Computer with 386 Processor or higher
- PC with a 3.5" diskette drive, Mouse and loaded with Windows 3.11 or higher, Windows 95
- Parallel Interface (printer connection at the Net On Air decoder)
- VGA card with 256 colours or more
- 10 MB of free RAM, plus free hard disk memory for receiving information
- for Net On Air: reception of the "Deutsche Welle" signal (via ASIA SAT 2 100.5 East)
- for Teletext Plus: reception of broadcasters that transmit Teletext services

The Net On Air Package

Includes

- Multifunctional Decoder
- Software Package
- Detailed Instruction Manual
- Net On Air Reception Licence
- Connection Cables
- Lead Adapter

Note: Decoder must be authorised by Net On Air Asia Pacific for you to receive the Internet. Teletext services are free of charge.

Decoder
A\$198⁰⁰

+ 22% Sales/Tax
+ Shipping & Handling

For information & bulk orders please call Peter Fischer on: 0061 7 5596 0962

SatFACTS MONTHLY

ISSN 1174-0779

is published 12 times each year (on or about the 15th of each month) by Far North Cablevision, Ltd.

This publication is dedicated to the premise that as we enter the 21st century, ancient 20th century notions concerning borders and boundaries no longer define a person's horizon. In the air, all around you, are microwave signals carrying messages of entertainment, information and education.

These messages are available to anyone willing to install the appropriate receiving equipment and, where applicable, pay a monthly or annual fee to receive the content of these messages in the privacy of their own home. Welcome to the 21st century - a world without borders, a world without boundaries.

Editor/Publisher

Robert B. Cooper (ZL4AAA)

Office Manager

Gay V. Cooper (ZL1GG)

Reaching SatFACTS

Tel: 64-9-406-0651

Fax: 64-9-406-1083

Mail: PO Box 330

Mangonui, Far North

New Zealand

Subscription Rates

Within NZ: \$50 p/yr

Australia: AV-COMM Pty Ltd, PO Box

225, Balgowlah, NSW 2093

61-2-9949-7417

Elsewhere: US\$60 p/yr

All copies sent via airmail fast post world-wide

ERRATA

SatFACTS Copyright 1997 by Robert B. Cooper; any form of copying is a violation of our international copyrights. Advertising rate sheet available upon request.

COOP'S COMMENT

Things that go bump in the night. The PanAmSat plan to software download the universe of S-A D9223 receivers with updated instructions appears to have backfired. Neither S-A nor PanAmSat will talk even "off the record" about what happened after our SatFACTS for September 15th "hit the street" but significantly, programmers such as Discovery stopped in midstream their upgrading process. Somebody has apparently been badly embarrassed by this scheme (see this page, September).

Things that go bump in the night. A 50+ page financial study of Sky NZ's assets by merchant banker Bancorp was apparently intended to create a springboard from which Sky could go from a privately held corporation to a public traded company (SatFACTS September, p. 22). Now comes the more difficult part - convincing New Zealand (and international) investors that Sky has a valuation of nearly (NZ)\$1 billion. This will be a difficult sale since Sky has managed to lose more than \$148m on day to day operations (through December 31, 1996) and people purchasing stock like some comfort that the company they are investing in has the ability to earn a profit at some stage. More recently, with the New Zealand government once again announcing that state owned Television New Zealand will be sold to private interests, it is difficult to find a proper balance between TVNZ's annual profits (approximately \$70m in the most recent year) and Sky's most recent losses (\$20.6 million). Moreover, TVNZ had annual sales in the \$300 million range while Sky reported annual sales in 1996 of \$132 million. What do all of these numbers mean? If Sky is worth nearly \$1 billion, as Bancorp claims, then should not TVNZ be worth considerably more than \$1B? It, after all, is profitable. Sky is not. And TVNZ had more than twice the annual sales of Sky. Yet the best price government hopes to realise for TVNZ is well under \$1 billion. Numbers that don't match up bother me; I suspect they will bother others as well. And we'll see how the stock buying public reacts when Sky "goes on sale" soon.

Things that go bump in the night. In Asia they make fun of CNBC and in those business and social sets where television broadcasting is the fodder for cocktail party discussions, there are more "CNBC jokes" than there are "Polish jokes" in Melbourne. Most of these "jokes" centre around on the air mistakes by CNBC personnel, a missed switching cue, a microphone which was left hot when it should have been turned off. Competitor ABN on the other hand gets good marks for its "technical correctness." There are very few - if any - ABN jokes at cocktail parties. Alas, ABN is a loser, a distinctively also ran second place service that is boring to watch, unimaginative in its coverage, second rate in its self-promotion. So it is not surprising to hear speculation that one of these two competitors will fold into the other one. Which one will survive? Which one deserves to survive?

Things that go bump in the night. Sky (NZ)'s plan to distribute free to air terrestrial television channels (TV1, TV2, TV3 and TV4) as a part of their digital bouquet may well turn out to be a red herring. Here's the rub. No NZ television network will say a single word about conversion to digital. Virtually every other country in the world has an analogue to digital terrestrial conversion time table. Those that don't have an announced conversion date at least have detailed studies underway. New Zealand has none of the above (Australia is talking about 2015 turnoff of terrestrial transmitters). The problem is dollars. The costs associated with building and operating completely new digital networks to operate simultaneously to and in parallel with the existing analogue transmitters. The first level costs are horrendous - well in excess of NZ\$200 million - perhaps as much as twice that. Then there are the operating costs, keeping two separate transmitter chains running for all four networks for ten years or more as the public slowly buys digital TV sets or accepts that at the least they will have to one day invest in a digital to analogue converter. Sky's offer to bring TV1, TV2, TV3 and TV4 nation-wide in the Sky digital satellite platform is a beautiful way around the multi-hundred-dollar investment none of the terrestrial broadcasters believe they can afford. Alas, who's the winner here? If New Zealanders rush out to buy satellite dishes with digital IRDs to get the benefits of terrestrial TV via digital delivery, every home that is so equipped automatically becomes a quickly-converted customer to Sky (NZ) as well. A pretty damned clever way of getting the public to buy satellite dishes so that Sky doesn't have to pay for them and putting off terrestrial digital - perhaps forever.

Things that go bump in the night. Sky (NZ)'s plan to distribute free to air terrestrial television channels (TV1, TV2, TV3 and TV4) as a part of their digital bouquet may well turn out to be a red herring. Here's the rub. No NZ television network will say a single word about conversion to digital. Virtually every other country in the world has an analogue to digital terrestrial conversion time table. Those that don't have an announced conversion date at least have detailed studies underway. New Zealand has none of the above (Australia is talking about 2015 turnoff of terrestrial transmitters). The problem is dollars. The costs associated with building and operating completely new digital networks to operate simultaneously to and in parallel with the existing analogue transmitters. The first level costs are horrendous - well in excess of NZ\$200 million - perhaps as much as twice that. Then there are the operating costs, keeping two separate transmitter chains running for all four networks for ten years or more as the public slowly buys digital TV sets or accepts that at the least they will have to one day invest in a digital to analogue converter. Sky's offer to bring TV1, TV2, TV3 and TV4 nation-wide in the Sky digital satellite platform is a beautiful way around the multi-hundred-dollar investment none of the terrestrial broadcasters believe they can afford. Alas, who's the winner here? If New Zealanders rush out to buy satellite dishes with digital IRDs to get the benefits of terrestrial TV via digital delivery, every home that is so equipped automatically becomes a quickly-converted customer to Sky (NZ) as well. A pretty damned clever way of getting the public to buy satellite dishes so that Sky doesn't have to pay for them and putting off terrestrial digital - perhaps forever.

In Volume 4 ♦ Number 38

Installing A 24 Footer in the Marshall Islands -p. 6

NEW Birds Announced - The Sky Overfloweth! -p. 15

Digital Update 97-7 -p. 18

Departments

Programmer/Programming Update -p.2; Hardware/Equipment Update -p. 4;

SPACE Notes: Low Look Angles -p. 20; CABLE Connection: Agility -p. 22;

SatFACTS Orbit Watch -p. 24; MPEG-2 Tuning Parameters -p. 26;

Digi Notes Reference Information -p. 28

With The Observers -p. 29; At Sign-Off (MediaNet and other Foibles) -p. 32

-ON THE COVER-

On the tiny island of Roi-Namur, at the northern end of Kawjalein Atoll in the Marshall Islands, a group of American space-age technicians and scientists install an Orbitron 24 footer to bring in "home town TV." Richard Brooks reports on a location where a 24 footer is 1/15th the size of other neighbouring dishes!



October 15, 1997



LETTERS

FREE Microwave - Forever?

"We have a client wishing to receive Galaxy/Foxtel via a microwave antenna. Will I be able to guarantee availability 100% or will this system be encrypted in the near future?"

J.W., Melbourne, Victoria

At least two Australian firms are selling MDS microwave "decoders" which receive and process free of subscription charges the 2 GHz region terrestrial MDS (multi-point distribution service) signals available via Galaxy (Foxtel) in the major centres. It was foolish of Galaxy not to properly encrypt the services, depending largely upon the non-common frequency as a deterrent to "piracy."

Most countries have laws against 'tuning in' these transmissions without the authorisation of the transmission source; Australia apparently does not prohibit this practice. Galaxy, under Foxtel (Murdoch) will likely upgrade the system with a form of encryption not dissimilar to that used with CA satellite services. For now, Taiwanese built decoders sell for A\$400-450 and self-installers must also spend typically A\$120 for the antenna-LNB combo. There have been hardware problems (power supplies equipped with 60 hertz transformers, resulting in overheating of epoxy-coated parts) and that aside, anyone investing up to A\$600 in the hardware to privately receive the MDS transmissions is betting Galaxy under Foxtel will not upgrade the MDS encryption scheme.

Where Do Old Satellites Go?

"What happens to spent satellites; is there a satellite heaven? Being 36,000 km above the earth, are they ever at risk of going to hell?"

T. Gillan, Mashpee, Ma, USA

Unlike old soldiers, old satellites do indeed die. And like their counterpart humans, some die prematurely (India's 2D this month is an example). Old satellites can present a removal problem. One feature of getting old is their exhausted fuel supply. 'Out of gas' takes on new meaning when the nearest BP is more than 36,000 km distant. A well planned satellite utilises its last precious ounces of fuel to jettison into space above the magical 36,000 geostationary orbit belt, akin to being sent to heaven (if one assumes heaven is still 'up' even from the satellite's elevated perspective). This does not always work out, especially when a satellite dies prematurely. So, many dead satellites are simply parked at the side of the road where over time the forces of the sun and gravity will drag them back into the earth's ionosphere where they will be consumed in a fiery finale not unlike being sent to hell.

2 more choices self-made coming

OK FSI 1 MacBarr 10 Nuz Buss. m 16

PROGRAMMER PROGRAMMING PROMOTION UPDATE OCTOBER 15, 1997

"Hot" DVS-211 units. On heels of our extensive report on the Pace DVS-211 "Murdoch Platform" receiver (SF#37, p. 6) comes word that in Philippines DVS-211s are being freely promoted at US\$3,340 inclusive of year's programming from Indovision. Buyers to date have been Filipino cable operators who are "sharing" their reception with subscribers. ESPN and STAR TV have reacted by publishing notice in Manila newspaper warning against "signal theft" but at least one dealer is not concerned: "I am ignoring their warnings," he told a SatFACTS reader. Price may not be out of line for cable operator's who are "stealing" Indovision service channels, but it is more than 3 times the street price in Jakarta for the same hardware and year's subscription.

NHK's policy against allowing non-Japanese redistribution of their two BS3A/B Ku band channels has been relaxed for the Philippines. As reported in SF#35 (p. 31), creative Filipino installers have been offering US\$2,000 DTH systems for this service which apparently is intended via an Okinawa spot beam only for Japanese consumption. Filipino cable operators, ever aggressive, had found a sizeable audience for the two channels and had added them to their cable line-ups. NHK now realises it cannot stop this from happening, and created affiliation programme that allows Filipino operators to "legally" redistribute the two channels, for a fee.

Francophile up-date. RFO now advising "we will stay on present I180 (701) beam pattern until at least end of 1998." Service and various French sources have been hinting at switch to eastern-hemi beam which would, if true, preclude viewing of RFO east of Tahiti and Cooks. RFO 2? Still promised, latest word is "by end of 1997."

Francophile update 2: Raymond Wohler (Wohler Communication Telediffusion, Papeete) reports "New French language digital bouquet that will include Canal + service to be available on a DTH subscription basis should begin tests around the end of this year on I180. Service will be MPEG-2, require smart card, cost in vicinity of NZ\$50 per month and be on same (RHC) polarity as RFO." Intrigued? Telephone + +689-43-23-78 or fax + +689-42-01-19. Tel-689-54-40-00 Fax-689-54-40-05

CNBC-ABN? Asian television programming circles are abuzz with reports ABN will close down and be absorbed by CNBC. ABN reps deny this is happening.

PAS-2 temporarily FTA digital but weaker than heck: 4180V, Msym 20607, FEC 2/3 includes CTN1, CTN2, TVBI, feeds, CTN2 and CTN4; same line-up as Hong Kong PowerVu. This bouquet is opposite polarity to CCTV bouquet and there may be a connection here - ultimately. (Also check 3718Hz, same parameters, PAS-2)

Thaicom 1 at 120E has new digital package at 4120V, Msym 27500, FEC 2/3: HSTV Ch 3, Army TV Ch 5, BBTV Ch 7, MCOT Ch 6, TVT Ch 11 and ACTO-ITV. Has anyone south of the equator located this?

Perhaps not for long: Indovision package from C2 at 3580H has also been running on C2 4117H (the old MTV Asia transponder) at Msym 26850, FEC 7/8. You might also check 4180V (same parameters) as well.

Southeast Asia Games feeds have been running on Palapa C2, 4180V at Msym 24060, FEC 3/4.

JcSat 5 launch delayed to November 27th; JcSat 6 is now scheduled August '98.

ApStar 1A at 134E has MPEG package testing 4060V, Msym 28330, FEC 7/8 with programming for Taiwan and Philippines.

Indovision on Palapa C2 has added new bouquet at 3460H (Msym 21000, FEC 7/8); content TVRI, RCTI, SCTV, IVM, TPI and ANTV (see SF September, p. 8).

WATCH



YOUR LETTERBOX!

Especially if you are a member of **SPACE Pacific (*)**. There is a **REALLY BIG** surprise announcement coming to you the last week in October concerning the 1998 South Pacific Region Satellite & Cable Show.

Two clues:

#1/ For the first time ever - registration will be strictly limited to a number significantly smaller than 100.

#2/ You will be going on a trip to a very special place!

Sorry - no advance notice. First to sign up, first reserved. There has never been an event like this in the South Pacific. And there may never be again!

*/ If you are NOT a member of SPACE Pacific but are interested in SPRSCS '98 - return the data request card on page 34 TODAY. Those who are too late this year will simply be out of luck!

HARDWARE EQUIPMENT PARTS

UPDATE

OCTOBER 15, 1997

AsiaSat 3 Dec. 12 Launch
SINUSAT 1 Launch Mark Now 25 Jan

AsiaSat 3, SF is told, will "probably not launch (Proton) until the 2nd week in December." Recent advisories had mentioned November 25th, but some minor delays are now expected to push that back a few weeks. The satellite will, of course, fly to 105.5E and assuming an early to mid-December launch, turn on at the end of January as a replacement for AsiaSat 1 at that location. AsiaSat 2 kindly "turned on" for SPRSCS '96 just in time to liven up the annual show; "3" could well do the same for SPRSCS '98!

InSat 2E will, when launched (to an exact position not announced but likely to be one held for India), have nine C-band transponders under lease to Intelsat. Of these, four will cover from Eastern Europe to Australia (suggesting a location in the 80 - 90E region) with 36 dBw forecast. The remaining five transponders will be 37 dBw but limited to China, SE Asia and India.

Orion 3 is now scheduled for October 1998 launch to 139E; on board the HS601 platform: ten C-band transponders (36 MHz) and 33 Ku (of which 23 will be 54 MHz wide, two 27 MHz, and eight 36 MHz). Ku downlink range is to be 12.25 - 12.75 GHz, same as Optus birds. Australia and New Zealand will be inside the projected C-band coverage; on Ku: Four separate beams one of which is dedicated to Oceania. Orion will control the new satellite from a TT&C in Hawaii. Orion has a major customer pre-signed: Korean Dacom which plans some form of DBS delivery on 8 Ku transponders.

Long time waiting **Columbia Communications Corp** says it is finally ready to proceed with construction of a hybrid C and Ku band satellite for 172E; the next slot "over" from PAS-2 (PAS-8 will go to 166E, the next slot in the opposite direction from PAS-2). Columbia already operates the commercial traffic side of TDRS 5 at 174.3W (providing TV feeds north to Japan fed from the USA) and has used the TDRS operation to build a client base sufficient to support, they believe, a satellite of their own. Launch window? 1999-2000.

Palapa C1, originally at 113E until they figured out it was semi-defective (SF April, May, June 1996), has been repointed at its 150.5E location. The new transmit antenna alignment makes it possible for New Zealand and eastern Australia to fall into 38dBw footprints on 6 (horizontal) transponders and even allow for uplinking from the South Pacific. What's missing? Customers. CNBC appeared on 4160/990H September 30th along with other "test" carriers at 3730, 3790, 3820, 3930, 4010 and 4120 (all horizontal). There is a mystery in all of this; CNBC is on the CFI-equivalent transponder (of C2) and we all know how strong CFI is - virtually every place. Yet the CNBC signal is P2 or P3 at best on 3m dishes in NZ and eastern Australia. If (IF!) C1 is running saturated on CNBC, and this is as good as it gets, something is very wrong at the satellite!

ST-1, the Singapore Telecommunications Ltd. hybrid C + Ku band bird scheduled for 88E, now says it will launch in April 1998. The bad news is that the newly released C and Ku footprints clearly show it is an Asian only satellite. 40.4 dBw eirp on 14 C-band transponders will include India east to Korea and Japan, south only to Indonesia (NW Australia may get a whiff of this one with 4m+ dishes). Ku is in 2 beams (Ku1, Ku2) with India alone in one (51.4 dBw) and Taiwan, Philippines, SE Asia (less Indonesia) in another (49 dBw).

InSat 2D (72.5E), never important in most of our lives, has gone to satellite heaven. The bird lost "earth lock" October 1 because of a power supply failure and was abandoned in place October 5th.

Local has bought Orion

ADL[®]

BECAUSE PERFORMANCE IS ALWAYS YOUR FIRST PRIORITY

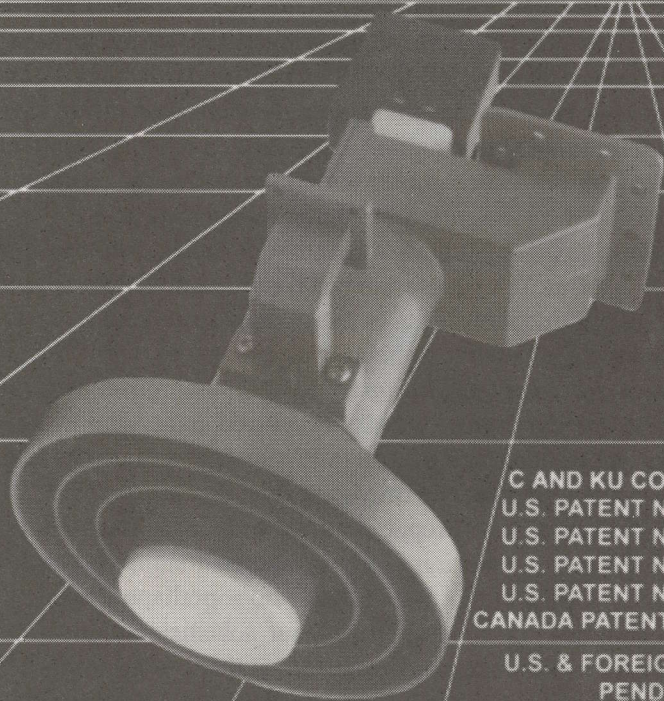

**RP3-CKU/ International
Adjustable Scalar Ring Feed
with Extended C Band**

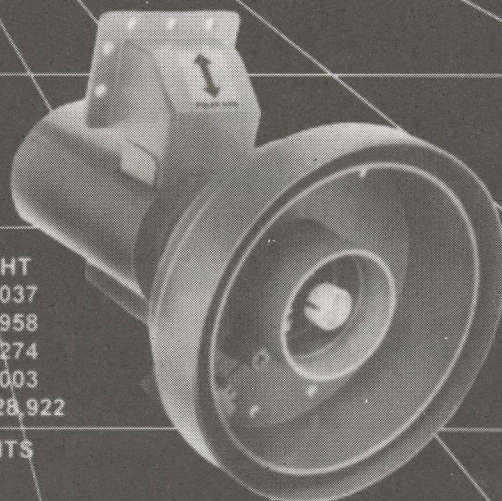

RPI-CKU Feed

C AND KU CO-BORSIGHT
U.S. PATENT NO. 4,903,037
U.S. PATENT NO. 5,066,958
U.S. PATENT NO. 5,107,274
U.S. PATENT NO. 5,255,003
CANADA PATENT NO. 1,328,922

**U.S. & FOREIGN PATENTS
PENDING**

ADL HYBRID MODING CIRCULAR POLARIZED INTELSAT FEEDS WITH EXCLUSIVE T.I. REJECTION



RP1-CP400

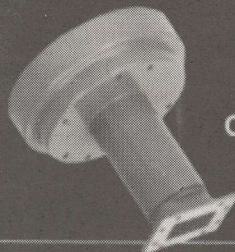

CP-300



CPOR-100

- C BAND LINEAR & CIRCULAR • C/KU LINEAR & CIRCULAR • KU 12 GHz FEEDS
 - INTELSAT 4 GHz CIRCULAR • ARABSAT S BAND FEEDS
- OPTIONAL: CO-BORSIGHT S BAND

2216 AGATE COURT, UNIT B, SIMI VALLEY, CALIFORNIA 93065 • (805) 526-5249 • FAX (805) 584-0634

E-mail: ADL@thegrid.net • Web site: <http://www.thegrid.net/adl/>

BRINGING A TINY ATOLL IN THE MARSHALLS INTO THE 21st CENTURY

Where It Is-

Roi-Namur is a small island located at the northern end of the Kawjalein Atoll in the Marshall Islands (9.4N x 167.23W). The population is 300, all DOD (US Department of Defense) contractor personnel who combine to operate a radar tracking station. Under the direction of the US Army Kawjalein Atoll (USAKA), Roi-Namur radars track everything from space debris to the Shuttle. As you might expect, this tiny island is a wealth of technology with four major tracking radar dishes ranging from 60 feet to over 160 feet in diameter. Because of the nature of what we do here, we even have a T1 (wideband data) class link to the United States for telecommunications.

Why Satellite TV-

As unlikely as it may seem, with all of the leading edge technology at our disposal, our television connection to the world was limited to AFRTS (Intelsat 177E). While AFRTS provides up-to-date sports and news coverage, the residents of this island wanted more (sound familiar?). In this day of world-wide satellite communication, should we really be isolated from our homes in the states? Are we, in a remote corner of the globe, capable of receiving the stateside television we had all grown accustomed to viewing?

Is It Possible?-

The first hurdle was the perception that satellite television (beyond AFRTS) was impossible because of our location. It was amusing to me that while our staff includes some of the more brilliant minds in telecommunications anyplace in the world, there was a

lack of local knowledge of the satellite explosion occurring directly above us. With the assistance of the folks at Baylin Publications and their TSC TVRO analysis software, we determined that indeed, satellite TV was quite feasible. Further research led us to John Lynam at Bay Satellite TV Ltd in New Zealand. John rapidly became an invaluable tool in our quest for satellite TV, information assistance and most recently working our way through the confusing world of digital IRDs. More importantly, John introduced me to this publication which quickly put me in touch with a world of satellite TV professionals and serious enthusiasts throughout the Pacific. At last, I had the resources to tackle the challenge at hand.

Armed with charts, graphs, computer printouts and maps, a handful of newly converted paper-enthusiasts set out to convince the island's supreme authorities that satellite TV was not only possible but affordable. To our dismay, well prepared as we were with intelligence and logic, we were initially no match for the hysterical ravings of a single individual who - perhaps fearful of losing his job if he approved our scheme - simply said no. Success looked pretty elusive at that point.

OK, as they say - we would go to "Plan B." This involved a "small dish" installed with the aid of donations from Island residents. A 12 foot Orbitron mesh dish and a Drake receiver - pointed at PAS-2 and BINGO! We were watching CNN International. I love life when you do something that everyone (or most everyone) insists cannot be done. Needless to say, a few jaws dropped and more importantly we then found no opposition to our larger plan. Approval followed.

The Obstacles-

Due to our unique location, we faced problems which the average dish installer will never have to deal with. Roi-Namur's very high power tracking radars are amongst the most sensitive such installations in the world (1). The radars wipe out everything electronic on the island - common household TVs, radios, tape decks simply fold up and quit from massive energy overload (2). There are more problems. Roi-Namur was a battlefield during WW2 and it is categorised as a historic site. Much of the ground is archeologically sensitive and digging in the ground requires massive piles of paperwork before the digging can begin. Pick the wrong location and teams of archaeologists would be called in to inspect the site. And Lord help us if they actually find something there - our project could be set back years!

The author attended SPRSCS '97 in Auckland to refine his understanding of the technology involved in bringing first time television to a remote spot on the globe. This is not your average "Let's put in a dish" story as you will quickly understand!

Richard Brooks, PO Box 8458, APO AP 96557;
Email brooks@kmmrmail.kmr.ll.mit.edu

1/ A recent technology publication dealing with military systems reports the Roi-Namur technology has the ability to detect a missing re-entry heat shield tile on the Space Shuttle when it passes overhead at several hundred miles altitude; akin to spotting a VW bus in traffic in New York City from a radar located in Los Angeles.

2/ Which is one reason why this installation is isolated from the world on Roi-Namur.

Couple these unique problems with an increase in cost as we moved our projected TVRO dish site from the authorised headend site and you can quickly see why costs might escalate beyond reason. The dish and building to house the new satellite receiving equipment would be erected at a site 600 feet from our Communications Center. This site has the advantage of providing a clean and clear shot to the west and it also has some protection from the normal trade winds. A steel warehouse located just to the east would also double as a "shield" to protect us from the massive radar system outputs when the 160 foot radar dishes were pointing in our general direction. From this building, we hoped that we could send baseband video and audio from the receivers/converters located there via a fibre optic cable to our Comms Center where it would be received, modulated and RF combined with our normal AFRTS channels. Since our cable system is designed around North American standards (funny, that) we are limited to (NTSC) VHF channels 2 - 13. Ideally, perhaps, we would not operate on adjacent channels (suggesting a maximum of 7 channels) but doubtless as this project grows we'll end up like a modern cable system using all 12 of the channels commonly available to us (3).

Finally, since this is an (U.S.) Army base, operating a (commercial) CATV system was out of the question. We had to set up the project as a community service with no subscription charges or user fees. All of the labour intensive installation would be accomplished by volunteers (the promise of many new channels of TV programming secured a long list of helping hands). The Army agreed, in approving the project, to fund up to US\$30,000 for equipment only; any subscription or other programming fees after the installation would also have to be paid for with donations.

And then there was the legality question. While a backyard enthusiast is quite free to set up a dish and sweep the skies from horizon to horizon chasing elusive signals, distributing these to the rest of the "neighbourhood" is quite another matter. To ensure the strictest possible compliance with both the letter and the intent of the law, we need written permission for redistribution of any programming we might wish to receive; whether FTA or encrypted! This might sound like a terrible challenge but the nightmare was not quite so bad as it might seem. Here is why.

3/ Actually, with cable converters or cable ready TV sets connected to the system, there are 24 possible NTSC TV channels between 54 and 216 MHz. (editor)

4/ Most US programmers have a policy of authorising Department of Defense non commercial distribution systems to carry US programming sources without fees. Most likely, letters requesting such permission from Roi-Namur simply failed to reach the appropriate person in each organisation.

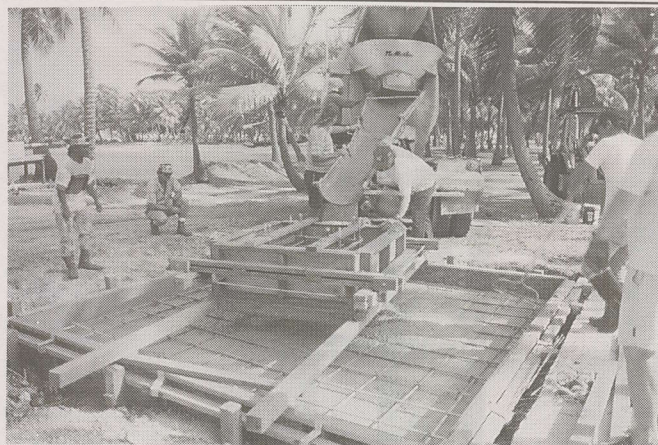

How many "communities" of 300 people have their own, local, concrete "company?" Building a dish base in the tropics is pretty much like anyplace on earth.

1) All inhabitants of Roi-Namur are military or Department of Defence contractor personnel (for reasons that should be obvious given the high tech nature of the work done from here, no tourists or casual visitors ever set foot on the place).

2) The system is a closed loop, no transmission (nor reception) off the island could occur.

3) No local cable provider exists, thus no existing "market" is being encroached.

4) The entire system is operated on a not-for-profit basis; no subscriptions are collected.

With these points in mind we set out to solicit free of charge service from the programmers on PAS-2 and Palapa C2.

Charles Jablonski, Vice President of NBC Broadcast Engineering and Carolyn Gossman, Director of Special Markets for Country Music Television quickly granted us permission to receive and distribute their respective services at no charge on our island. Others, including Discovery and MTV, offered their channels at greatly reduced rates. I must admit that some others have simply never replied (4).

The Plan-

The \$30,000 budget was what we had to create a small building to house the equipment, acquire and install a suitable dish, equip it with a dual pole feed and LNBS, acquire suitable analogue and digital receivers, run the baseband video to the Comms Center, modulate the signals to an RF channel for distribution within the existing AFRTS/cable network, and buy all of the miscellaneous parts we would need. As we began with an Orbitron 24 foot dish and mounting tower, the budget was going to be tight! We would end up purchasing the equipment shown here (see "Equipment," page 8). This would give us three new, full-time, channels with the option of going up to six before having to add new fibre optic cabling. It helped that our ship-to point was an

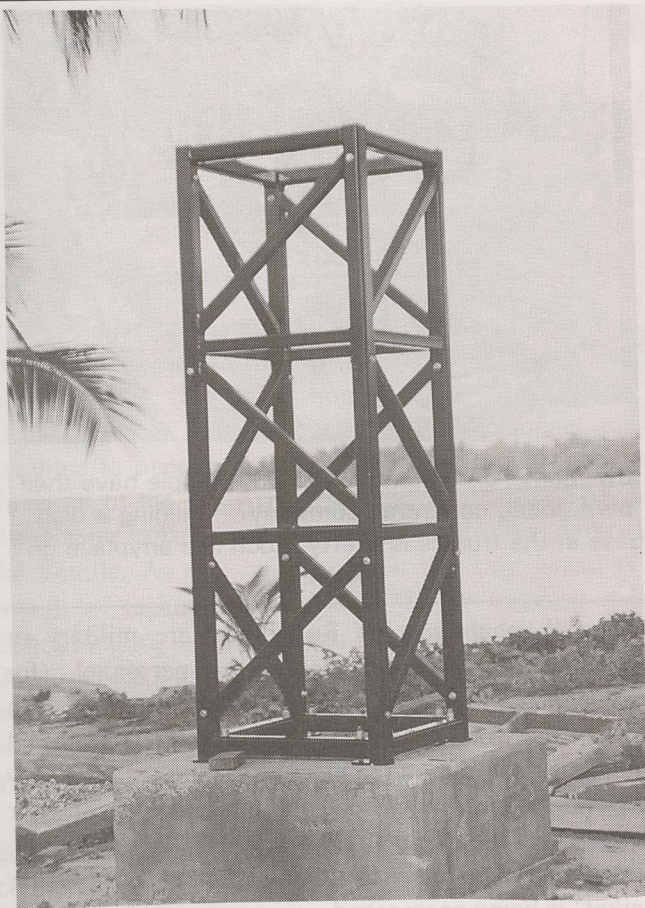

Tower sections stack to elevate dish centre to ensure ground clearance at the lowest antenna system look angles.

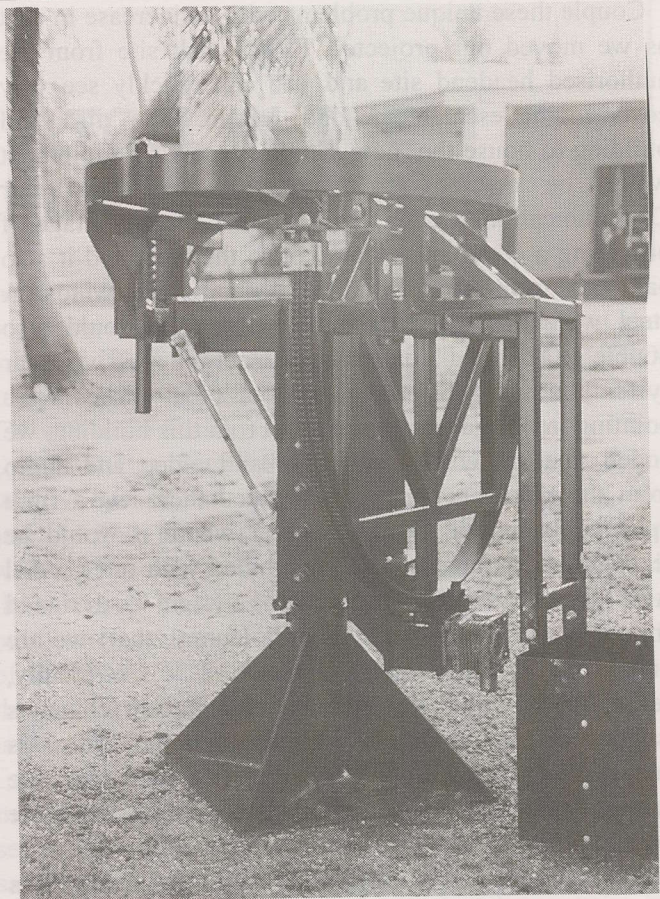

In short order the T24 "pieces" begin to add up to some very significant weight. Here, the tower-topping dish support and rotational system.

address in California (the Army saw to it our equipment including the 24 foot Orbie was then carried to Roi-Namur) and we acquired most of the equipment in the USA. The exception were the digital receivers which at the time were simply not available stateside (it is amusing to me that the Pacific region actually leads the states in the implementation of digital TV transmissions) and which we acquired through Bay Satellite TV in New Zealand. As all construction, installation and maintenance was to be done by volunteers, once we had the plan in place with all approvals, and the equipment on order, there was only one logical thing to do; go on vacation!

SPRSCS '97-

Having wanted to visit New Zealand for years, and our satellite dish components just starting to arrive, I decided to make the trip to Auckland and SPRSCS '97. Not being from the 'biz (so to speak) I was not sure how

I would fit into this gathering of satellite *wizards*. But then, I am not overly shy and decided I would simply jump right in and see what happened.

As I had talked with John Lynam all of those times and was anxious to meet the man behind all that email, I showed up the day before the 1997 show got underway and introduced myself. Within minutes I had a wrench in my hand and was getting first hand, practical experience assembling and aligning dishes. Great! I learned more about this special field in two days than I could have picked up on my own in a year plus of trial and error. Some people really stood out; Alan MeHarry of SatNet NZ was typical. He explained everything he did and why, and showed me tricks to the dish + signal peaking process that actually made it fun! I still don't understand how someone can look up into the blue sky, twist the mount by some seemingly random amount, and pick up the satellite on the arc in perfect azimuth. No

The Equipment That Went Into Roi-Namur

- 1) Orbitron 24' dish with tower;
- 2) 6 Blonder Tongue NTSC frequency agile modulators;
- 3) 3 Opti-Mark Fibre-Optic transmitters and receivers;
- 4) 4 MPEG-2 digital satellite receivers;
- 5) 2 Drake 700E Multi-Standard analogue satellite receivers;
- 6) 5 Ten-Lab Multi-Standard digital converters;
- 6) Chaparral orthomode (dual polarity) C-band feed with 17 degree LNBS;
- 7) L-band signal splitters, 6 conductor fibre optic cable, RG-6 "ribbon" cable, connectors.

The Nokia Mediamaster DVB 9500 S.

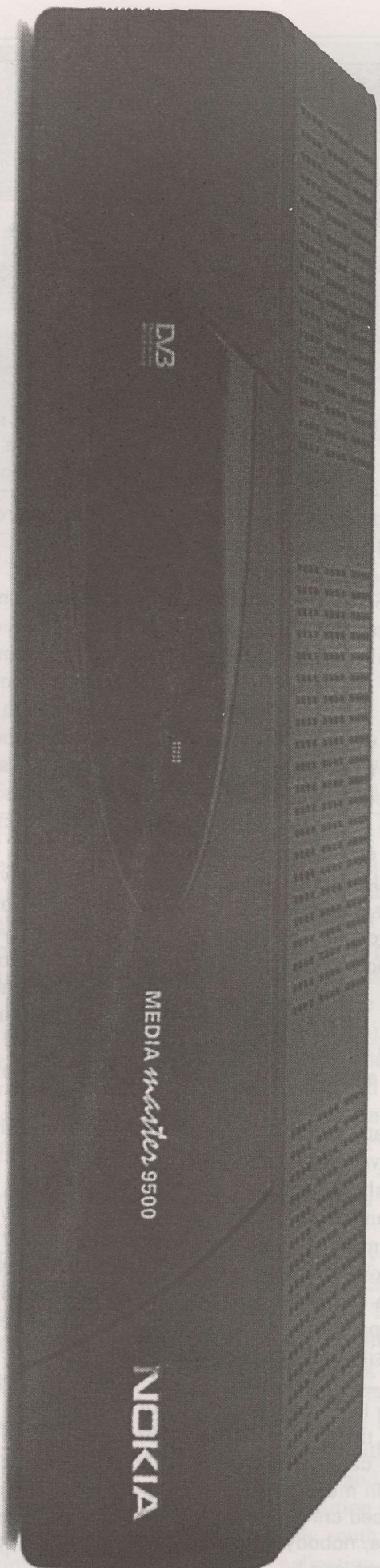

Brings the power of multimedia to your TV.



TEL 61-2-9584 1233 • FAX 61-2-9584 1452

• 99-105 BOUNDARY ROAD, PEAKHURST NSW 2210 AUSTRALIA • Email opac@internet-australia.com



The T24 goes together pretty much like its smaller 12 foot cousins - only there are more pieces and they are larger!



The job that nobody fights to do - "clipping" the mesh onto the trusses and frames. When all is said and done - this is a thankless task.

compass? No analyser? As Alan repeatedly said to me - "Sure, you use those things but just to verify what your TV set is already telling you!" Utterly amazing how much a person can learn at SPRSCS. The show was great and armed with hours of hands on experience, I returned to Roi-Namur confident this was going to be a piece of cake.

The Installation-

The bulk of the materials were on hand and construction began. A concrete pad measuring 12' by 12' by two feet was required; not your typical backyard installation. Atop the 12 by 12 pad we had to build a 4 foot by 4 foot by 2 foot riser to create enough room under the dish so that it could track horizon to horizon without hitting the ground on either end of the arc. The Orbie comes with its own bolt cage and they claim the dish will stand up to 100 mile per hour winds. After you build one, you will probably agree.

Now for the fun. Nobody on the island had any experience with a dish this size (the 160 footers are done by special teams that come, install and leave and the 12 foot test Orbie was child's play). The directions that come with the antenna were adequate but an installation video for first-timers would have been immensely helpful (5). All pieces were plainly marked and extra hardware (nuts, bolts, even mesh panels) were included.

First, the tower. This was simply a 4 piece bolt together construction job. Each tower section weighs around 150 pounds and they go on top of the bolt cage (which protrudes up through the pad). The first piece must be held in place while positioning the second.

5/ There is a famous story in the industry concerning instruction manuals that advise things like, "an experienced crew of 3 can assemble this antenna in two working days." In many cases, it is impossible to find an "experienced crew" because after doing the antenna one time, nobody is willing to do it a second time. Thus there can be no such thing as an "experienced crew!"

After they are bolted together, the tower is self-supporting. This is a job for three husky guys, minimum!

In our situation, the building construction was next or parallel. Our needs were quite simple - a small air conditioned room to house a few racks of equipment. A 12 foot by 16 foot cinder block building was constructed and covered with a plywood roof.

Then comes the mount. This is where you really get a workout as no single piece of the mount weighs less than 200 pounds. The process is simple enough but you will need some muscular people with good stamina to do it safely.

Finally there was the dish. Frankly, assembling the 24 foot Orbie is not a big deal. There are no mental challenges if you can read and follow directions although the work is tedious and anyone in a hurry should be assigned to some other aspect of the project. Shortcuts, a failure to follow the established and proven procedures, will only result in workmanship errors and degraded performance. The reflector is pre-assembled at the factory, checked for symmetry, all parts are numbered and then the support structure disassembled for shipping. This means the reflector can be assembled face up without worrying about malformation (but do make certain you assemble the pieces in their correct numerical order!). The trusses are two pieces each. Unless you have someone on hand to balance the reflector assembly, I suggest you attach the outer truss halves at 180 degree intervals to maintain a zero center of gravity.

The mesh support brackets attach to the trusses. Each of the sixteen trusses support nine mesh support brackets. All of the mesh support brackets fit firmly. The only problem encountered was a hole in the outer section of truss number 1 not completely drilled through; a minor problem quickly rectified on site.

The mesh panels come in varying sizes. The pie shaped pieces go on the supports first, nearest the spool. From there the pieces are trapezoid shaped and grow larger as you reach the outer edge of the reflector.



The dish is really starting to take shape. Bill Kostka and Jim Bramblett tighten the truss bolts at the spool while Robert Ferguson and George Lord install the last of the mesh support brackets.

Ensure there is sufficient overlap between panels (Orbitron recommends 3 inches). The mesh lays out easily on the trusses and mesh support brackets and is held in place with aluminium strips screwed to the top of each truss. The T24 comes with self-drilling screws and a socket attachment for your hand drill to screw these strips down. This job went surprisingly fast and was totally easy. Once the inner panels are in place and the aluminium strips screwed down, install the mesh hooks. By installing the hooks as you work outward towards the edge of the dish, you are ensuring the mesh is flat and this allows easier access to insert the hooks from the top (down).

With the mesh in place, the next step is the aluminium mesh trim. To be frank - I found these pieces impossible to install if you follow the Orbitron instructions. The trim is crimped onto the mesh using Orbitron supplied Vice-Grips (customised by adding 6" welding steel to the jaws!). The trim would not crimp properly, was difficult to hold in place and in the end we used pop rivets.

Finally, putting all of the pieces together into a functioning antenna. A note of caution for first time big-dish builders: Orbitron apparently assumes that anyone purchasing this dish has the people and equipment to assemble it. The pieces are very heavy, the mount alone must weigh 1000 pounds. Fortunately, we had a Sky-Track (lifting device) available to us. First, the mount and tower plate are lifted to the tower and

bolted into place. The mount is then rotated to face south (or north if you are below the equator). Next the reflector is lifted face up and placed onto the hub ring (mount). This rolls off my fingers very easily but in reality there are seven people involved; minimum. The reflector spool (center of the trusses) is equipped with a pair of lifting eyes. We ran straps through these eyes to the Sky-Track (crane). To ensure the dish stayed horizontal and as an aid to locating the spool over the hub ring, we positioned four people at 90 degrees apart each with a tether line. And, two more people are stationed on the tower to guide the reflector "home." Add the crane operator and you have seven people. One word of caution - you would never attempt this on a windy day!

As we had the Sky-Track available, we elected to assemble the feed horn including support legs and wiring on the ground. Then, with a man in a basket on the Sky-Track, we lifted the entire assembly into position without having to rotate the reflector.

When the reflector is in place, the mount is coarsely aligned. It would have been handy to have a transit for siting the assembly with known co-ordinates but as we did not, I used my hand held GPS. How? Pace off south and adjust my position so that the GPS indicated I was travelling exactly south; and, fix a reference point. We then set the inclination and declination offset using the



Bob Maddock guides the mount to the working position atop the tower.

Inclinometer (needle equipped protractor) we purchased from Skyvision in the states. A small notation here: The needle on the inclinometer is approximately 1 degree wide. That may sound like close enough for government work with most dishes but with a 24 footer you need much better definition. A digital level (with tenth of a degree readouts) would improve this situation remarkably.

The azimuth motor is installed. It was our decision not to install the elevation motor nor the limit switches. We would not be tracking any inclined orbit satellites and under normal operation the azimuth motor will be disconnected anyhow. This gives us a "spare" motor for the dish azimuth movement.

Alignment was textbook if you have done alignment before. The exception here is that you are 25 feet in the air, lashed to a crane, while adjusting the feed. I am not keen about heights, did not savour the assignment but because of my SPRSCS '97 experience knew I was the obvious choice. To adjust the feed to the center of the dish (feed to dish alignment) we used a laser pointer (the type used during lecture room presentations).

A round plug, cut to fit into the feedhorn opening, was fabricated with a hole at dead center. The laser pointer fit into this hole and after checking the positioning, it created a bright red dot on the dish center plate. The task of fine tuning the dot to the exact center of the dish center plate was a piece of cake.

The day was rapidly coming to an end and this provided an opportunity to fine tune the mount. If Alan MeHarry had been on hand, I am sure he would have yanked the dish to some magic spot in the sky, said "There!" and turned it on. (6) We had our own local secret weapon; Bob Maddock, our resident optical guy, had it worked out. Older TVRO textbooks talked at

6/ With all respect due to Alan MeHarry and others of that "skill" level, it becomes more and more difficult to "point and shoot" as the dish size increases. Anyone that can point and shoot a 24 footer has very unusual skills! (editor)



Dennis Jackson and Robert Ferguson in position as the reflector is lowered down onto the mount.

some length about using the pole star as a reference. It works very nicely for those of us north of the equator. The pole star is just below the Big Dipper and *always* directly above the north pole. An accurate fix on the pole star will fix your azimuth and inclination to within 1/4th a degree. To this end we fashioned a makeshift telescope. A 2 foot length of 1.5 inch diameter pipe had notches cut into it at 90 degree separations. Then some fine string was placed across the pipe to create cross hairs (see drawing, here) at both ends.

When you look through the pipe you will see the front and rear cross hairs. Now mount the pipe to the dish elevation arm (masking tape will do) making certain the pipe is flat and parallel with the edges. With sufficiently dark and clear skies, it is time to fine align the mount. We position ourselves in back of the pipe, and looking along its edge, have our assistants rotate the entire dish and mount to line our pipe up with the pole star. Once the azimuth is close, adjust the elevation. OK, now look into and through the pipe. The idea here is to line up both sets of cross hairs with the pole star, adjusting the azimuth and elevation as required. Absolute accuracy is not necessary (a function of dish size - the larger the dish, the greater the accuracy recommended); when you

Front of Pipe

Back of Pipe

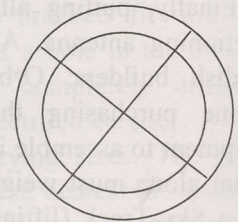
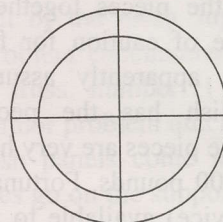

ACESAT'S

FIRST EVER WAREHOUSE SPRING CLEARANCE SALE!

**EVERYTHING FOR SALE OLD & NEW
ALL AT RIDICULOUS PRICES**

NEW STOCK & SECONDS

ANTENNAS & DISHES, LNB'S, RECEIVERS,
FEEDHORNS, ACTUATORS

AND MUCH MUCH MORE!!!!

AMS, PARACLIPSE, CHANNEL MASTER,
NOKIA, CHAPARRAL, GARDINER, ZINWELL,
SCIENTIFIC ATLANTA

YOU'LL NEVER BUY AT THESE PRICES AGAIN!

A full list of items for sale is available by fax
send your details to **Fax 61-2-9526 2206**

ON SITE ONLY

Friday 31st October 10am - 6pm

Saturday 1st November 8am - 12noon

Cash or pre-arranged cheque only



7/32 ENDEAVOUR ROAD CARINGBAH - PHONE (02) 9526 2411

are satisfied the pole star alignment is dead-on, tighten down the mount bolts and elevation rods.

Fire It Up!-

The alignment complete, a Drake receiver and spectrum analyser were connected. Ensure a DC block is connected in line with the spectrum analyser lest you damage some rather expensive equipment (7). And confirm the analyser is connected to the same line as the receiver (as the receiver normally will supply power to the LNB). We drove the dish upward to an elevation (here) of 78 degrees (remember - we sit almost under the equator!) and sure enough - there was PAS-2. We then fine tweaked the azimuth for the strongest signal and headed down the arc to Palapa C2. The signal was weak, but there. Readjust the azimuth and declination and back to PAS-2. After several fine tweak passes, minor adjustments each time, we were satisfied that the dish was tracking the arc very closely. Now we let the Drake 700e receiver do the rest. The information with the Drake was unimpressive because it was very much out of date (B2P at 113E amongst others), but the Auto Satellite Program feature is very impressive. Simply select the satellite name you wish and press start. The Drake will rock the dish back and forth looking for and automatically fine tuning each satellite.

By this point our building was complete. The 19" equipment racks were installed with forced air cooling (again, remember where we are!) and we began installing equipment. Due to the extreme nature of our environment, we decided to shield the ribbon cable from the LNBS in conduit, and bury it. This we hoped would add additional shielding from the massive megawatt radars just down the road a piece. Receivers, PAL/NTSC converters and fibre optic transmitters were connected and a 4-way splitter distributes the IF from the LNBS to the receivers. Note that with a dual C-band feed, one splitter and associated rack of equipment is dedicated to horizontal polarity and another for vertical. We clearly marked each lest we panic at some future time trying to figure out why signal levels were not up to what they should be.

And so, after nearly a year from start, the system is almost complete. Current projects include final electrical wiring, pulling the fibre optic cable and

Reception Results at Roi-Namur with Orbitron T24

Measat 91.5E

VTV/1440H/ P5

AsiaSat 2 100.5E

ERTU/1508H/ P5

TV Shopping Network/1490V/P4

TV Mongolia/1470H/P5

WorldNet/1265H/P5

Palapa C2 113E

SCTV/970V/P4; MTV Asia/1030H/P2

TPI/1070H/P4; Indosiar/1090V/P3

ABN/1120H/P3; Anteve/1130V/P2

CNNI/1183H/P2; TV3/1250V/P4

ATVI/1270H/P3; TVRI/1310H/P3

RTM/1330V/P3; RCTI/1408V/P2

CNBC/1530H/P3

No signals: CFI, Brunei, GMA

PanAmSat 2 169E

NHK/1114H/P5

CNNI/1183H/P2

CNN Feeds/1155H/P1

TVSN/1400V/P1

installation of the air conditioner unit. Testing to date reveals more than adequate signal levels from PAS-2 and AsiaSat 2. The Palapa C2 levels are lower than expected (8); this might be caused by a rather large palm tree which obscures approximately 25% of the dish surface. Hopefully after we "relocate" this tree, levels will be up to As2 signals. A table here shows the initial testing results.

7/ The LNB can be powered from the analyser if it has been designed for TVRO use (i.e., with built-in power supply for LNB powering). If not, a DC block to protect the analyser, or, a power pass one leg only splitter can be employed for receiver powering.

8/ The Palapa C2 levels may not be totally a function of tree blockage. Tests reported in detail in SatFACTS (April and May 1996) indicate there are significant "holes" in the 113E coverage pattern in the region of the Marshall Islands. Another potential problem is the "skew" realignment required of the orthomode feed for signals arriving at the relatively low C2 look angle.

small, medium and **LARGE C** and Ku antennas in stock!

Transmit and receive antennas from 1.2m to 13m (Intelsat Standard B). Linear and circular feeds (AsiaSat, Palapa, JcSat, Rimsat, PanAmSat, Intelsat and more) for transmit and receive-only applications. Receive and transmit electronics including inclined orbit tracking equipment with motor drives for elevation and azimuth to 50 tons. Complete system design, fabrication, installation + proof of performance.

P
A
C
I
F
I
C



Limited

A
N
T
E
N
N
A
S

Pacific Antennas Limited

Bryon G.G. Evans, PO Box 265, Whangaparaoa, NZ
Tel/fax 64-9-424-0841 • Mobile 025-789-160

STILL MORE - SATELLITES FOR THE PACIFIC & ASIA

Although the Pacific and Asia lag far behind Europe and North America in "satellite transponder capacity," there is every indication this is a temporary situation that will correct by the turn of the century. If they don't do this, smaller dishes on the ground are unable to properly separate the alternate satellite transmissions.

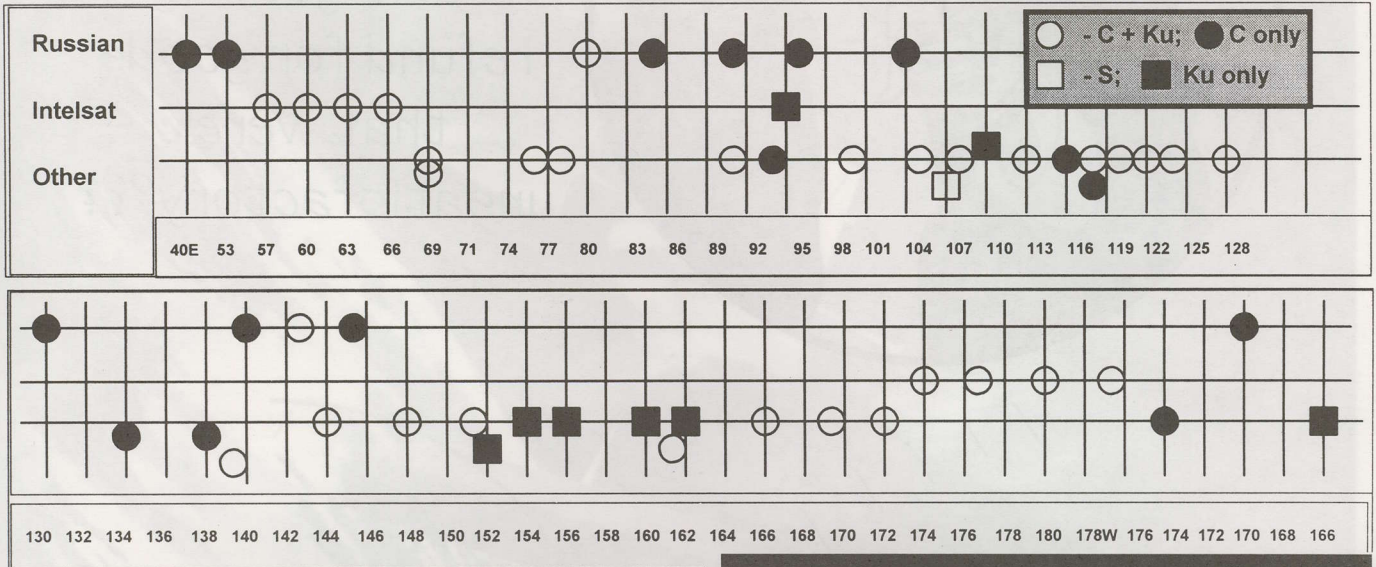

will correct by the turn of the century. The charts here illustrate the orbital arc loading in mid-2000 based upon announced satellite construction and deployment schedules. Against our present situation, the major additions announced (for the Pacific) include:

- 1) **AsiaSat 3** to replace AsiaSat1 at 105.5E (December 1997 launch, January 1998 turn-on with C and Ku);
- 2) **AsiaSat 4** to 122E by early 1999 with C and Ku;
- 3) **PAS-8** to 166E by late 1998 with C and Ku;
- 4) **Orion Pacific (3)** to 139E by late 1998 with C and Ku;
- 5) **Thaicom 4** to 120E by early 1999 with C and Ku;
- 6) **PSN** (Indonesia) with "Super Power" C-band to 118E (134E second choice) by early 1999;
- 7) **Columbia-Sat (1)** to 172E with C and Ku by early 2000.

As the charts illustrate, some segments of the "sky" are filling more rapidly than others. There is a particular "battle" in the region between 118 and 130 as what has previously been a "hole" is being filled with satellites from numerous different countries. Satellites originally maintained a 3 degree orbital arc spacing (from satellite to satellite) at C-band but with some careful polarisation planning and agreement between adjacent orbit spot operators, 2 degree spacing has proven possible. The trick is to get competing satellite operators to agree to the modifications required to make 2 degree spacing work. Satellites must agree to use opposite polarities on the same frequencies if 2 degree spacing is to work

Distribution centre of DVB MPEG-2 digital receivers for FREE-TO-AIR satellite TV programmes.

Wholesale & Retail Welcome

Consumer grade ---
HYUNDAI (HSS-100C),
NOKIA (DVB 9500S),
PACE (DSR 200)

Professional grade ---
DMV (System 3000),
Hirschmann (DVB7500)
Philips (DVS 3950/11)

Satellite IF distribution equipment --
GLOBAL.

Come and visit us if you pass by Hong Kong!

Hong Kong Satellite TV Ltd., Unit C, 7/F, Block 6, Tien Chu Centre, 74 Pak Tai St, Tokwawan, Kowloon, HONG KONG
 tel: (852)2736-8703
 fax: (852)2735-0583
 email: hkstv@netvigator.com

✓ YES, please send me info about _____ brand Company _____
 Detail address: _____
 _____ p'code _____
 Tel: _____
 Fax: _____



UNCLE BAYSAT ASKS

have you ever had
trouble getting a
refund for goods
that were
unsatisfactory???

DEAL with BAYSAT
and rest easy
in the knowledge
you are PROTECTED
by a 7 day
money back guarantee * -
NO QUESTIONS ASKED!

Don't get
caught out
ever again
with a deal
that comes
unzipped!

* - The fine print. As long as goods are returned in 'as new'
condition with original packing intact.

BAY SATELLITE TV LTD

YES!

We STILL accept
VISA, Mastercard with
NO surcharge!

PO Box 3311 • Napier, New Zealand • tel toll free 0800 - BAYSAT
International 64-6-843-5296 • Fax 64-6-843-6429 (0800 - 229-728)
Physical location • 19B Carnegie Road, Onekawa, Napier
<http://www.baysat.co.nz>
e-mail john@baysat.co.nz

**THE NEXT BEST
THING TO BEING
HARD WIRED
TO THE BIRD...**



**... The Palcom SL-7900RP
first choice of satellite
experts, performance
conscious installers and
quality driven consumers
across the Pacific and Asia.**

SL-7900RP: 500 channel memory Hi-Fi Stereo satellite receiver with full motorised actuator dish control built-in. Two IF inputs (950-2050 MHz); Standard 27/18 MHz IF bandwidths, plus 32 step threshold extension for signals as weak as 3dB C/N; Fully tuneable audio sub-carrier range (5.5 - 9.5 MHz) independent on L and R channels; Selectable wide (280kHz) and narrow (150kHz) audio bandwidth with J17, 50uS or Hi-Fi 1600 de-emphasis; Full polarizer control; TV modulator (E21-E69) + 3 SCART 21 pin outputs, separate L and R RCA audio outputs. Every function (including antenna, feed settings) logged into memory for instant recall - totally automatic channel search with companion handheld IR remote. Consistently rated by leading publications "Most versatile, low threshold, ultimate consumer receiver" world-wide. Truly, the next best thing to being hard wired to the satellite.

SL-7900RP from Bay Satellite TV Ltd, P.O. Box 3311, Napier, NZ. Tel 64-6-843-5296 (Fax 64-6-843-6429)

with software by....

PALCOM

State of the Art Simplicity

DIGITAL HARDWARE and PROGRAMMING UPDATE 97-7

From a programming point of view, the 30 days of September ended with an abrupt bump in the night; there are actual fewer available (as in FTA) services as October starts than there were as September began. The losses were across the board - from the seemingly no-harm-done transmission of the ABC (South Australia) MPEG feed on PAS-2 Ku to the total loss of the SPACE TV Systems service on Intelsat 177E Ku.

From a hardware viewpoint, those who are Hyundai fans appear to now have had their faith in this receiver validated with the appearance of a "do everything Hyundai" software version just as this issue of SatFACTS goes to the printer. The new version misses nothing, according to Leon Senior at Skandia, and more than fixes any of the old hang-ups which enthusiasts previously complained about (or silently accepted).

Missing?

The PAS-2 Ku band feed from Telstra (Australia) Bendigo uplink (Victoria) of ABC South Australia disappeared from FTA view October 3rd. The service began as a test in late June (SF July, p. 14) and was clearly a landmark event; the first time Australian television was being uplinked to a non-Australian satellite for distribution to Australian locations. It was all a part of the deregulation of satellite (and cable) that went into effect July 1st. The initial test had an ABC "national" service and NT broadcaster Imparja sharing a narrow MCPC sliver with two audio only services (ABC radio, Imparja radio). Shortly the two TV services went CA and a month later the ABC service was replaced with ABC South Australia, and it was FTA.

Perth telecaster GWN meanwhile had announced its own decision to use PAS-2, Ku, PowerVu format, to distribute programming to approximately 3,500 HACBSS locations that are currently served with analogue B-MAC. GWN's decision was contrary to plans at ABC which intended to stay within the Optus "Aurora" platform and the decision has drawn many negative responses. GWN indicates it will abandon the B-MAC feed sometime during the first half of 1998, and it claims it has "reserved" digital bouquet space for ABC as well. Although ABC has purchased PowerVu for its own links, it is not in favour of the S-A service for domestic (home DTH) service. And seemingly, where ABC goes so too will ethnic broadcaster SBS follow. And the issues are even more complicated by the uncertain future of Optus Cable service facing a

November turn over of existing DTH provider Galaxy to the Telstra-Murdoch-Packer camp. If Optus Cable's future is uncertain, they have no incentive to go ahead with their own plans to create a competitive to Galaxy DTH platform. The Optus Vision service has been testing, most often with freeze frame video or video without audio (Disney, et al) or the reverse - audio and freeze frame video.

In a nutshell, Australian DTH is in disarray and no element of it - not even the conversion of HACBSS from B-MAC analogue to MPEG - seems to have a steady course plotted. If you are looking for hard answers - you won't find them here. Or, anyplace else at this time.

In the hardware area, Hyundai by reports to us (subject to verification and our own testing, scheduled for a report in November) are all favourable. Hyundai seems to be heavily relying upon feedback from their (Australian) distributors to sort through the software changes necessary to make the HSS-100C a first-rate receiver. As we reported in SF for September (p. 19), three new software versions have been tested. One of these got the green light late in September and Leon Senior of Skandia was expecting the first delivery of the new software chips before October 15th. What this means is that anyone with an existing HSS-100C version can upgrade their earlier software by changing two chips. The chips plug-in, a task that can be done by anyone qualified to insert ICs into sockets. The new software is in the chip set and immediately the receiver is upgraded to do glitch free NTSC, PowerVu, increasing the number of storable channels to 100 (from 60), adds an on screen signal level meter and a carrier to noise ratio display which will be very useful for aligning dishes. And, the new software forces the receiver to return to last bouquet channel displayed after the power has been cut (making it useful for cable and SMATV headends).

So what is the difference, now, between a Nokia e3 and the version 3 software from Hyundai? The Nokia still has the unique ability to search out new digital signals. However, if you know the digital parameters (input frequency, Msym, FEC) and enter it into the Hyundai through the remote control, it will find the new services, load the service and retain it in memory. In other words, the Nokia will find new services on its own while the Hyundai has to be told where to look.

As a practical matter, most users will not be out there searching for new services; they will wait until somebody announces (such as here in SatFACTS) the

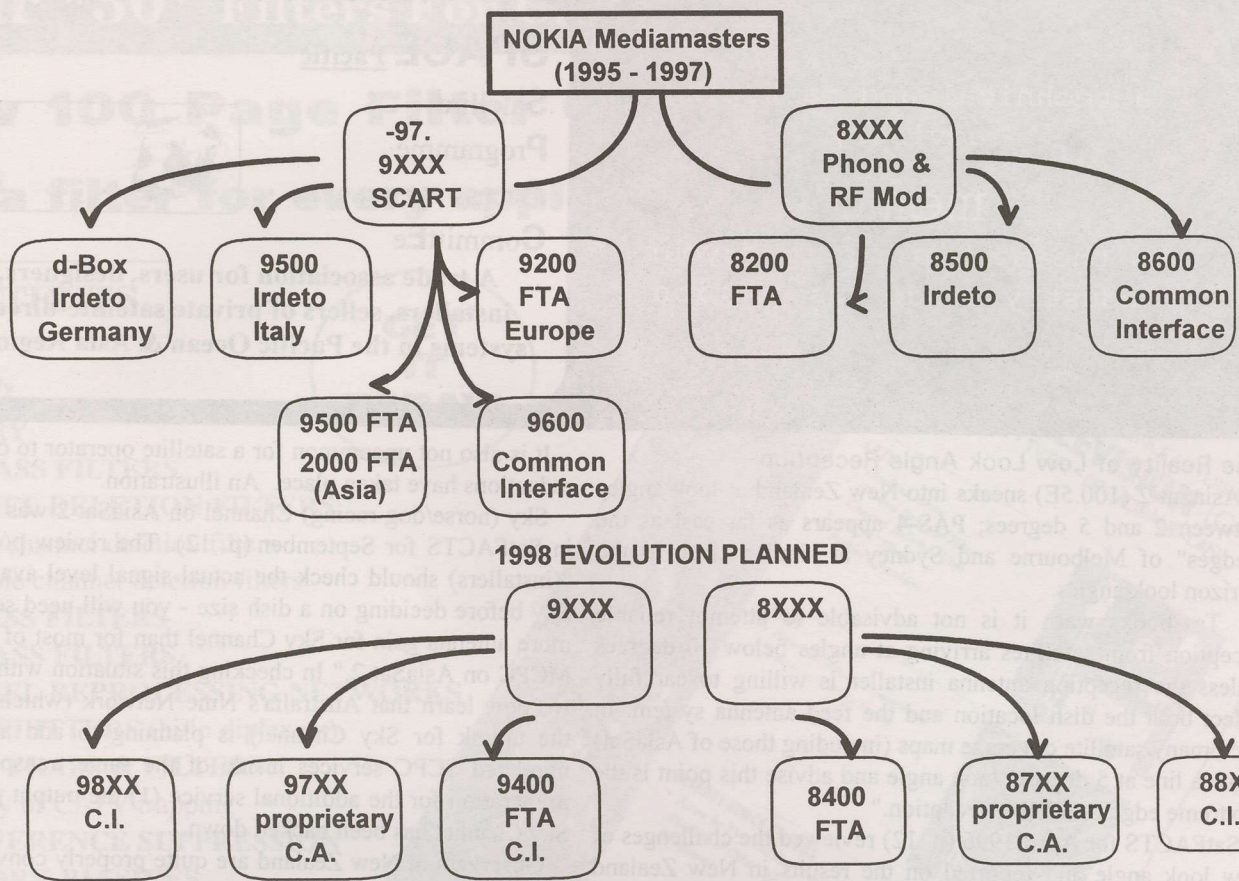

The chart above may help you better understand the proliferation of Nokia Mediamaster versions now in the market. Actually, this chart does not address all of the subtle variations in software that have been offered and doubtless a more complete chart could be created. Note the 1998 "Second Generation" plans will further challenge the marketplace to keep up!

appearance of new services and then enter them into their (Hyundai) receiver memory. To support the Hyundai, Skandia is setting up an Internet Web site which will update listings.

Nokia Mediamaster versions to date, and planned for 1998 release, are shown in chart form (above). The 9XXX series are equipped with SCART plugs while the 8XXX series have (RCA) phono jack outputs for audio and video and include an RF modulator. The 9500 / 2000 "Asian Series" should in theory all be identical but

in fact may not be because of software variations. Note the plan in 1998 to release "proprietary C.A." (conditional access) versions. Interpret that to mean receivers designed under contract to work with formats such as (but not necessarily specifically) PowerVu.

Due out in the next 30 days: S-A "consumer version" PowerVu designed specifically for Australian use. For an update on the PanAmSat over the air software upgrade, see p. 1.

STATUS of Operating and Near Term Planned DBS/DTH Pay TV Services in Pacific & Asia

	Astro-Malaysia	DirecTV Japan	Galaxy Australia	IndoViz MPEG	IndoViz Analogue	ISkyB India	JSkyB Japan	Optus Viz Australia	PerfecTV Japan	Sky NZ Analogue
Start Date	11/96	Late 1997	3/96	2/97	1,992	Unknown	April 1998	Unknown	10/96	4/97
# Subs Oct 1997	80,000	0	110,000 inc MDS	<20,000	<50,000	0	0	0	350,000	<10,000
# Pgme channels	20	70+	20+ > 11/97	19	4	17	150	Unknown	100	2
Satellite	Measat 1	Superbird C	Optus B3	Palapa C2 (1)	Palapa C2	PAS-4	JcSat 4	Optus B3	JcSat 3	Optus B1

a technical and marketing
advisory
memo
to the membership from your
industry trade association

SPACE Pacific

Satellite
Programme
Access
CommittEe



**A trade association for users, designers,
installers, sellers of private satellite-direct
systems in the Pacific Ocean & Asia Regions**

The Reality of Low Look Angle Reception-

AsiaSat 2 (100.5E) sneaks into New Zealand at look angles between 2 and 5 degrees; PAS-4 appears as far east as the "edges" of Melbourne and Sydney at similar close to the horizon look angles.

Textbooks warn it is not advisable to attempt reliable reception from satellites arriving at angles below 10 degrees unless the reception antenna installer is willing to carefully select both the dish location and the feed antenna system. In fact, many satellite coverage maps (including those of AsiaSat) draw a line at 5 degrees look angle and advise this point is the "extreme edge of reliable reception."

SatFACTS for April 1996 (p. 12) reviewed the challenges of low look angle and reported on the results in New Zealand after 90 days of AsiaSat 2 reception. We came to the conclusion that while it is possible to produce useful reception at 5 degrees (and below) there are reception compromises the system installer (and user) must accept.

After nearly two full years of AsiaSat 2 reception in New Zealand, a revisit seems appropriate. In April 1996, AsiaSat 2 loading (the number of transponders in use, the amount of power authorised for each operating transponder) was quite different from today's AsiaSat 2. We understand the present satellite loading to be at 85% of capacity, which means for all practical purposes there is only a small amount of "headroom" remaining. It is not uncommon for a satellite operator to allow individual transponder users to operate at higher power levels when a satellite is new and the loading (total use of the satellite) remains low. Nor is it uncommon as the satellite use goes up for small, incremental reductions in transponder operating power to occur. Over a period of 18 months or more, these reductions can easily amount of 2dB reductions in on ground measured signal levels and 3dB is within the range of expectations.

It is also not uncommon for a satellite operator to deny such reductions have taken place. An illustration.

Sky (horse/dog racing) Channel on AsiaSat 2 was reviewed in SatFACTS for September (p. 12). The review pointed out "(installers) should check the actual signal level available for Sky before deciding on a dish size - you will need several dB more antenna gain for Sky Channel than for most of the other MCPC on AsiaSat 2." In checking this situation with AsiaSat, we now learn that Australia's Nine Network (which operates the uplink for Sky Channel) is planning to add additional, unrelated SCPC services inside of the same transponder. In preparation for the additional service (1) the output power for Sky Channel has been backed down.

Observers in New Zealand are quite properly convinced the levels on all of the vertical polarity transponders on As2 have gone down, slowly over time, by as much as 3dB from the initial levels recorded early in 1996. Where this is hurting most are those installations which were put in without adequate "headroom" (margin between available signal and threshold on the receivers).

The message here is one of exercising greater care in selecting dish size based upon the apparent initial signal levels (when a satellite first goes into operation) versus the type of level to be anticipated down the road several years when the satellite loading has peaked. If a satellite is new and you have barely enough signal level to maintain reception, perhaps adding 2dB of additional antenna gain would not be unwise.

1/ Taking a wild guess at what the new SCPC service might be on this transponder, we are reminded that Nine Australia owns and operates Papua New Guinea's EM TV and EM TV has been planning a move to As2 and digital. Could this be the new home for EM TV after the new temporary analogue feed on As2 horizontal (p. 29)?

MEMBERSHIP IN SPACE

Membership in SPACE Pacific is open to any individual or firm involved in the "satellite-direct" world in the Pacific and Asia regions. There are four levels of membership covering "Individuals," the "Installer/Dealer," the "Cable/SMATV Operator," and the "Importer/Distributor/Programmer." All levels receive periodic programme and equipment access updates from SPACE, significant discounts on goods and services from many member firms, and major discounts while attending the annual SPRCS (industry trade show) each January in Auckland. Members also participate in policy creation forums, have correspondence training courses available. To find out more, contact (fax) 64-9-406-1083 or use information request card, page 34, this issue of SatFACTS. Page space within SatFACTS is donated each month to the trade association without cost by the publisher.

Year #30* Filters For Cable TV • TVRO • Interference

New 100 Page Filter Catalog

Has a filter for every application

- CABLE TV SYSTEMS
- SATELLITE RECEPTION
- OFF AIR INTERFERENCE

CONTENTS

CATV:

HISTORY

BANDPASS FILTERS

CHANNEL DELETION FILTERS:

Single channel deletion filters

Multiple channel deletion filters

LOWPASS FILTERS

HIGHPASS FILTERS

CHANNEL REPROCESSING NETWORKS

BANDSPLITTERS (hi/lo diplexers)

PAY TV TRAPS & FILTERS:

History of CATV trapping

INTERFERENCE SUPPRESSION

NETWORK PASSIVES

DROP LINE DEVICES

WEATHERIZED HOUSINGS

GET
IT
TODAY!

TVRO: FILTERS TO SUPPRESS INTERFERENCE

BOOKS: CATV, TVRO, MMDS, INTERFERENCE

APPENDIX A: INTERNATIONAL CHANNEL FORMATS

APPENDIX B: INTERNATIONAL CHANNEL FREQUENCIES

APPENDIX C: ORIGIN OF CATV, TVRO, PAY-TV

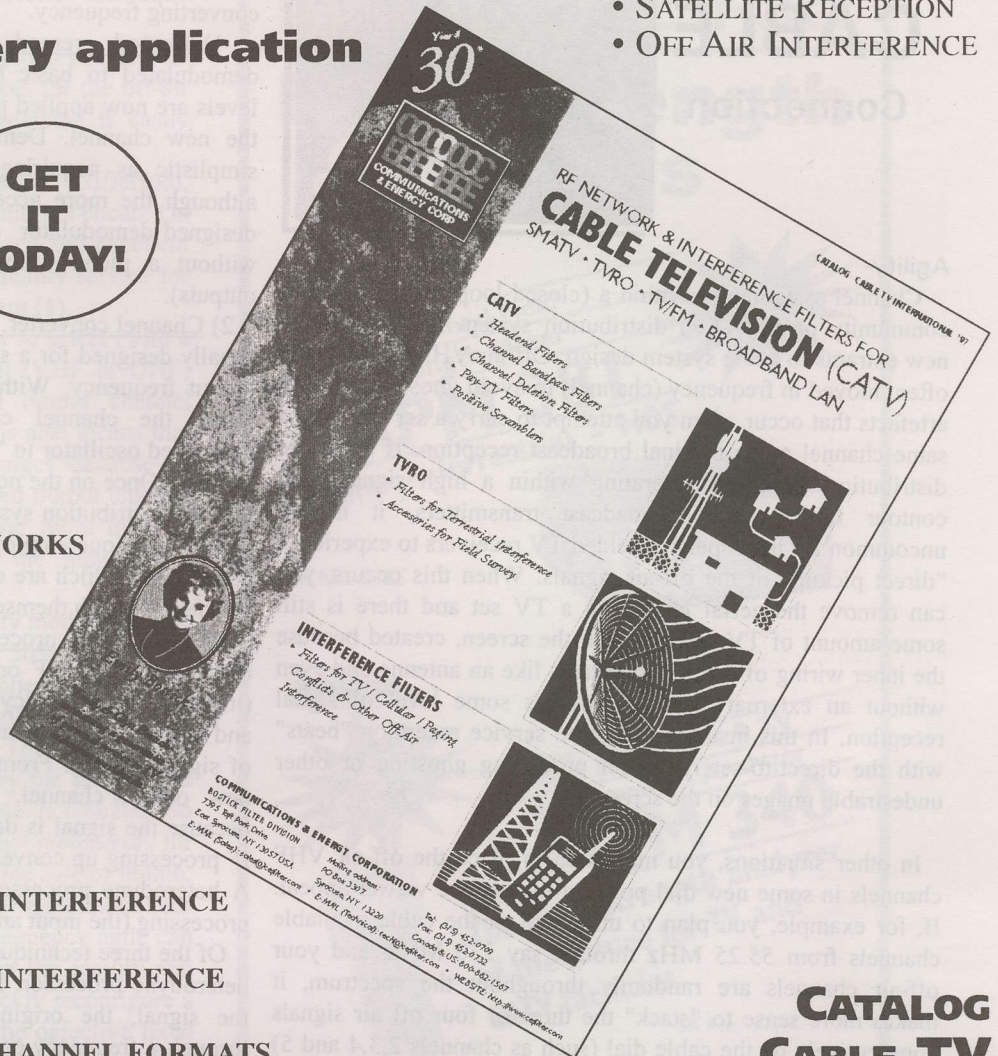

CATALOG CABLE TV INTERNATIONAL/97

More than a catalog of products -
It's also a tutorial on CATV history and practices.



Emily Bostick
President

Emily Bostick

***Emily & Glyn Bostick -
Continuing a generation
of personal service to
TV industries -WORLDWIDE!**



7395 Taft Park Drive
East Syracuse, NY 13057
Mailing address:
PO Box 3307
Syracuse, NY 13220
Tel: (315) 452-0709
Fax: (315) 452-0732
Canada & US: 800-882-1587

DISTRIBUTOR INQUIRIES INVITED

Telephone: 315-452-0709

Fax: 315-452-0732 USA

Literature: Ileen Feinberg

Technical: Dave Dann, Tracy Warren, Steve Shafer, Glyn Bostick

The CABLE Connection

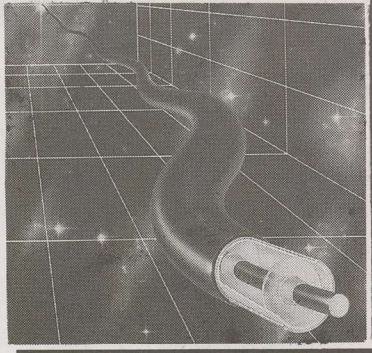

Agility-

Channel assignments within a (closed loop) cable (whether community or SMATV) distribution system often confound new entrants to cable system design. Off-air VHF channels are often moved in frequency (channel) to avoid ghosting or other artefacts that occur when you attempt to carry a service on the same channel as its original broadcast reception. If the cable distribution system is operating within a high signal level contour for the local broadcast transmitters, it is not uncommon for improperly shielded TV receivers to experience "direct pickup" of the off-air signals. When this occurs, you can remove the aerial lead from a TV set and there is still some amount of TV reception on the screen, created because the inner wiring of the TV tuner acts like an antenna and even without an external antenna provides some level of signal reception. In this instance the cable service reception "beats" with the direct-to-set reception producing ghosting or other undesirable images on the screen.

In other situations, you may wish to place the off-air VHF channels in some new dial position to enhance viewer appeal. If, for example, you plan to utilise all of the cable available channels from 55.25 MHz through say 230 MHz, and your off-air channels are randomly throughout the spectrum, it makes more sense to "stack" the three or four off air signals consecutively on the cable dial (such as channels 2,3,4 and 5) to make it easier for viewers to quickly find their familiar

off-air services in what with cable may become a bewildering selection of off-air plus satellite and locally generated services.

The technical ability to "move" an off-air VHF channel from its original frequency to a new one is basic to cable/SMATV system design. There are three acceptable methods of converting frequency.

1) Demod - remod. The incoming signal is received and demodulated to basic (baseband) video and audio. These levels are now applied to a standard (cable TV) modulator on the new channel. Demodulating a TV channel can be as simplistic as acquiring a TV receiver with A/V outputs, although the more accepted practice is to utilise a purpose designed demodulator (basically, a high quality TV receiver without a picture tube or speaker - equipped with A/V outputs).

2) Channel converter. This is a frequency translation device, usually designed for a specific input frequency and a specific output frequency. With any VHF (or UHF) channel as an input, the channel converter (typically) uses a crystal controlled oscillator to "beat" the channel to the desired output channel. Once on the new channel, it is amplified and "mixed" into the distribution system. Because of the crystal oscillator / "beat" technique employed, there are some channel to channel conversions which are considered "impossible" (they generate interference with themselves).

3) Heterodyne processor. This is a system that allows any input channel (VHF or UHF) to be "beat" to a common IF (intermediate frequency) where the signal is (further) amplified and automatic gain control is applied (to eliminate any effects of signal fading). From the IF, the signal is then rebeat to a new output channel. This is called "double conversion" because the signal is down converted to the IF and then after IF processing up converted to a VHF (or UHF) channel again. A heterodyne processor may also be used for same-channel processing (the input and output channels coincide).

Of the three techniques, the most technically "perfect" is the heterodyne processor. By not demodulating and remodulating the signal, the original broadcast "specs" are maintained through a frequency-only shift. By converting the signal to an IF (intermediate frequency) range, noise and other interference

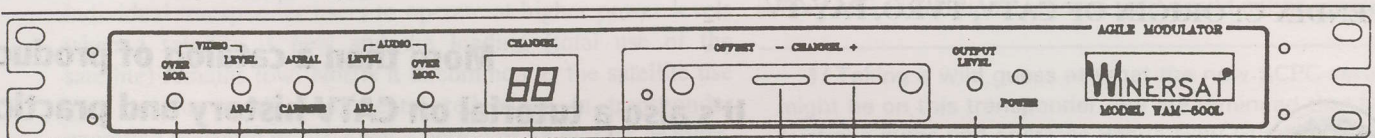

SIGNAL AGILITY is found in a number of reasonably priced PAL-B processor units; this, the Winersat WAM/500 series agile modulator covers 40 - 550 MHz channels at push of buttons

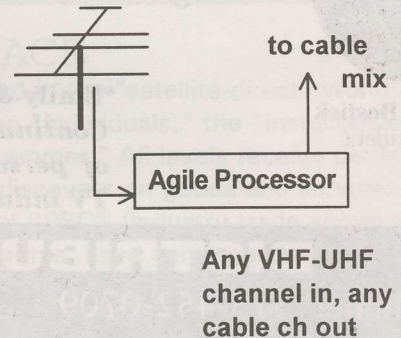
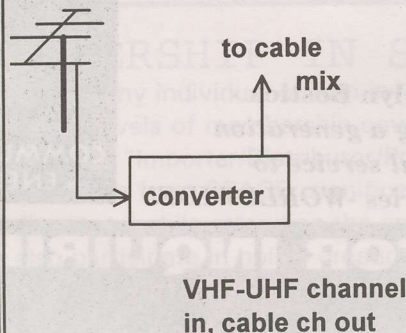
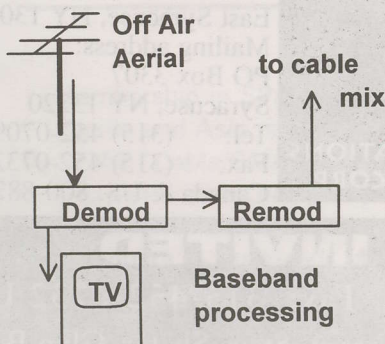

is corrected and because the signal has automatic gain control applied, any fading is eliminated (the output stays constant over a wide range of input signal fades). If there is variation in signal level, either the demod/remod or heterodyne approach is mandatory since the (crystal controlled) converter technique applies no AGC to the converted signal.

The demod/remod approach allows the system operator to easily substitute different programming sources for the off-air signal since baseband (audio and video) switching is easily accomplished at the input to the remodulator.

Costs? Name brand heterodyne processors (GI/Jerrold, Scientific Atlanta) easily top US\$1,200 per unit; not cheap. On the other hand, there are very reasonably priced and excellent performing units out of Taiwan which give quality service for less than half the cost of name-brand equipment (1).

Agility in signal processors allows the user to select (with a push of a button) any desired input channel (VHF or UHF) which is then converted to any desired output channel (typically between 40/48 and 550 MHz). This also means that if for some reason the input channel changes because of terrestrial broadcast changes, or, if the desired output channel for cable distribution changes, you are never more than 30 seconds away from totally reconfiguring the input/output channels to suit your new requirement.

The same agility is available in cable quality modulators and again the pricing out of Taiwan suppliers is 50% or less than that from the name brand stateside suppliers. For under US\$500 you can purchase a frequency agile modulator or frequency agile heterodyne signal processor. The same Taiwan sources sell fixed channel (the channel set by the factory and not field modifiable) modulators in the region of US\$200. So for pure economics it pays to use fixed channel modulators for most of your cable headend requirements. One rule of thumb: For every ten channels, substitute a frequency agile modulator for a fixed channel unit. Why? Because a frequency agile can be a substitute for any fixed channel unit in the facility and should a fixed channel unit fail, you can quickly reconfigure a frequency agile modulator to take over for the defective fixed channel unit until it is repaired. If you adopt this policy, try to use the frequency agile unit(s) on the least important TV channel(s) in the system so that if you have to turn off a channel because of a modulator failure by moving the agile unit to a fixed channel frequency, you are disrupting the smallest possible number of system viewers.

1/ Winersat from Canner Communication Corp,
Kevin Lao at fax + +886-786-1450; model
WAM-500SL agile modulator, WAP-600SL agile
processor

ENTERING THE PACIFIC MARKET?

Professional, hands-on assistance in reaching cable, SMATV, broadcast operators and DTH dealers.

Our expertise is reaching the "right people" with the "right connections" to make your new programming or product launch a success.

**SOUTHSTAR
Media Ltd**

PO Box 432, Orewa, NZ
Tel 64-9-406-0481

KONIG ELECTRONIC

Field Strength Meters

KONIG
ELECTRONIC

Combined Field
Strength Meter

APM 381

Satellite - Terrestrial - MDS

SK No. 5785



IDEAL
FOR
SAT TV - TV
& MDS
INSTALLERS

KONIG
ELECTRONIC

IDEAL
FOR
CABLE TV & TV
INSTALLERS

Hand Held Cable & TV
Field Strength Analyzer

APM 340

The Field strength analyzer
of the future for TV and
CATV facilities

SK No. 5777



KONIG
ELECTRONIC

Field Strength Meter
APM 746 SAT

Professional multistandard
field strength meter
for worldwide
application

SK No. 5788

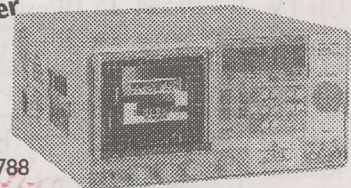

IDEAL
FOR ALL
PROFESSIONAL
INSTALLATIONS

For more information on our full range
of Konig Service Instruments &
Specifications please contact:-
Skandia (61 3) 9819 2466

Distributed in

Australia & NZ by

Skandia

Skandia Electronics Pty Ltd

Victoria: 183 Burwood Road Hawthorn, Victoria 3122 Australia
Telephone: (61 3) 9819 2466 Fax: (61 3) 9819 4281
NSW: Level 1, 39 Terry Street, Rozelle, NSW 2039 Australia
Telephone: (61 2) 9555 2955 Fax: (61 2) 9555 2455

SatFACTS Pacific/Asian Region Orbit Watch: 15 October 1997

Copyright 1997: SatFACTS, PO Box 330, Mangonui, Far North, New Zealand (Fax: 64-9-406-1083)

Analogue Free-to-Air 57E to 80E	
Sun Music	57E/703 1395R
Sun Mov.	1342R
Gemini	1220R
AsiaNet	1170R
WorldNet	1095R
NEPC	1085R
TVi	1025R
Muslim	975L
ESPN Feeds	64E/801 1134R
E-TV	1093/L
ViJAY TV	965R
Home TV	68.8/Pas4 Vt1310
ABN	Hz/1365
Sony TV (Hindi)	Hz/1240
Doordar & Iran TV	Vt/1116
CNNI	Hz/1065
TNT/Cart.	Hz/1040
ATN	Vt/995
MTV Asia	Hz/965
MCOT	78.5/Th3 Hz/1180
HSTV	Hz/1200
TVT	Vt/1280
Army TV NNV 5	Vt/1390
RAJ-TV	Vt/1510
UB TV	Vt/1534
Contin.TV	Vt/1565
Punjab TV	Vt/1605
TK Rossija	80/Exprs. 1475RHC
VTV4/ Mos. TB6	1275RHC
ACT/TB3	1225/RHC

Anal. Free-to-Air 80E to 113E	
Russia 3	80/Exprs 1025R
RTR 1	90/S6 1475R
Orbita I	1275R
RTR II	1234R
Orbita II	1215R
VTV	91.5/Me1 Hz/1440
Doordar.1 National	93.5/In2b 1030/Vt
Doordar.1	1160/Hz
Doordar.9	1080/Hz
Doordar.7 Telugu	1070/Vt
Doordar.9 Kanada	1180/Vt
Doordar.1	1268/Vt
Doordar.3	1348/Vt
Doordar.4	1388/Vt
ORT 1	96.5/S14 1475R
Madagascar	1325R
Tv Azer.	1275R
ERTU Egypt	100.4/As2 1508/Hz
TV Shopping	1490/Vt
Mongolia, Iran/plus	1470/Hz
EMTV	1385Hz
WorldNet	1265/Hz
CCTV4	1190/Hz
RTPi	1170/Vt
RTR Russia	103/S21 1475R
APT	1275R
CFI	113/C2 990/Hz

Anal. Free-to-Air 113E to 148E	
Brunei, feeds	113/C2 1010/Vt
MTV Asia	1030/Hz
TPI	1070/Hz
TV Indosiar	1090/Vt
ABN	1110/Hz
ANteve	1130/Vt
CNNI	1177/Vt
SCTV	1190/Hz
GMA	1240/Hz
TV3	1250/Vt
Austr. TV	1270/Hz
TVRI	1310/Hz
RTM	1330/Vt
RCTI	1408/Vt
CNBC	1530/Hz
Test Card	128/Jc3 1070Vt
CETV SD	134/Ap1A 1330Hz
CETV2	1250/Vt
CETV1	1170/Vt
CNNI	138/Ap1 1170/Vt
CCTV7	990/Hz
Orbita-1	140/S7 1475R
NTV	1425R
ViJay TV	142/R42 1325L
RTR Russia	145/S16 1275R
Test Card	148/Me2 1070/Hz

An. Free-to-Air 150E to 180E	
CNBC	150/C1 990/Hz
CNNI	169/Pas2 1183/Hz
CNN Feeds	1155/Hz
NHK	1114/Hz
TV Shopping	1400/Hz
Feeds	174/I802 984R
Feeds	973R
Feeds	177/I702 984R
Feeds	963R
Feeds	180/I701 1430R
Feeds	1175R
RFO	1105R
Feeds	1020L
Feeds	984R

PALAPA C1 150.5E	
CNBC	990Hz
Tests	1030Hz
Tests	1140Hz
Tests	1220Hz
Tests	1330Hz
Tests	1360Hz

Encrypted Analogue	
Discov. India	68.8/Pas4 1365/Vt
ESPN	1290/Hz
ESPN (d)	113/C2 1030/Hz
HBO Asia (d)	1150/Hz
TNT + (d)	1390/Hz
Discovery (d)	1430/Hz
Discovery (c)	169/Pas2 1374/Hz
ESPN (a)	1288/Vt
TNT + (a)	1218/Vt

NON MPEG-2 DIGITAL SERVICES

People's Net (GI 1.5)	113/C2 1220/Hz
RPN-9 (SA 1.5)	142/G2 1225L
Fox/Prime (SA 1.5)	169/Pas2/ 1161/Vt
Filipino Channel (GI 1.5)	1060/Hz

OCTOBER ALERT

ApSTAR 2R should be launching (Long March - we all know what that means!) as you read these words - headed for 77E at last word (again, nothing is ever certain with ApStar). See projected coverage map p. 31. Watch PAS-2 Ku, 12.287 and 12.300 for changes in the PowerVu network opulent loading as Australia moves closer to initiating PowerVu outback service. If your Nokia can do a full search, try PAS-2 C-band vertical looking for an MCPC bouquet that has 4 video channels (Encoder 1, Encoder 2 etc) for a surprise.

For MPEG-2 format digital, see pages 26/27.

Challenge? Russian MIR downlink analogue FM on 10.830 RHC.

66E / CNN, TNT MPEG on 11.138Vt, Fee 3/4
11.525R - YAMAC TV

VTV 1545Hz
Feeds 1215

ORT-1 - 1475

Oct 20?

Poss. EMU 4006 VT 4.333, 314 - YR. YHF - VORSE - VHA

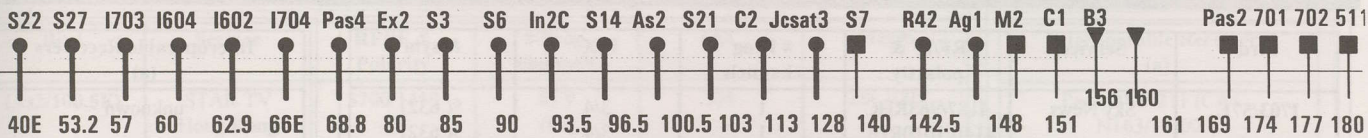

**OPTUS B3
156E
(Ku only)**

ABC WA	1358/Vt B-Mac
Central ABC HACBSS	1393/Hz B-Mac
Imparja	1355/Vt
MPEG Tests	1328/Vt
GWN	1300/Vt
Net 9, Sky specials	1233/Vt B-Mac
ABC NT/ Imparja N.T.	1201/Hz (centre) B-MAC
Galaxy	1137/Hz Irdeto Mpeg 2
Galaxy	1073/Hz Irdeto Mpeg 2

Optus A3/152E(a)

ATN7png	1297/Vt
ATN7png	1430/Vt

a/occasional use

**Palapa C2 Ku
(seen South equator)/113E**

Test bars	11.148/Vt
-----------	-----------

**MeaSat 2
148E**

Tests	1070Hz*
-------	---------

* Colour bars, audio 6.8;
C-band covers
Australia., NZ

(a) B-MAC encrypted, no access available; (c) MPEG, encrypted, access may be possible (d) B-MAC, subscriptions available in some geographic areas.

**OPTUS B1
160E
(Ku only)**

Data	1402/Hz
QSTV	1377/Hz B-Mac
SE ABC HACBSS	1370/Vt B-Mac
SE SBS HACBSS	1344/Vt B-Mac
NE SBS HACBSS	1339/Hz B-Mac
NE ABC HACBSS	1313/Hz B-Mac
Sky Channel	1296/Vt B-Mac
ABC Radio	1276/Hz (digital)
OmniCast	1270/Vt (FM/FM)
ABC feeds	1247/Hz Pal
Sky Nz (sport)	1245/Vt VidCrypt
Net 9 feeds	1220H B-MAC
Sky Nz (Orange)	1218/Vt VidCrypt
Net 10	1182/Vt E-Pal
Net 9	1180/Hz E-Pal
Net 10 feeds	1155/Vt Pal
QTQ9	1145/Vt
Net 7	1120/Vt E-Pal
Net 9 feeds	1091/Vt Pal
Aurora MPEG-2	1076/Hz (tests)
CAA air to ground	1009/Vt Nbfm

**PAS-2
169E
(C + Ku)**

CCTV	1433.5/Vt (Sa9223)
Napa feed	1407/Hz
Value Ch.	1400/Vt
Discovery PowerVu	1374/Hz (Sa9223)
Napa feed	1370/Vt
AB Asia, feeds	1335/Vt
WCE-TV, feeds	1250/Vt
MPEG-2 PowerVu Sylmar	1249/Hz (Sa9223)
TNT+ (1/2Tr)	1218/Vt B-Mac
CNN+ (1/2Tr)	1183/Hz
FoxSports	1160/Vt (SA 1.5)
NHK	1115/Hz
Feeds	1092/Vt
Napa feed	1065/Vt
ABS/CBN (5 chs)	1064/Hz (GI 1.5)
NBC Mux MPEG	1057Vt (Philips)
MPEG-2 PowerVu HonKong	1002Vt (Sa9223)
TCS Sing.	967/Hz

see p. 27 detailed MPEG listing PAS-2

PAS-2 Ku

MediNet	12.287V
Telstra Bendigo	12.300V (MPEG)
Napa TC	12.415V
HiLife	12.582H
MTV Asia	12.604H (MPEG)

**Intelsat 801
174E**

Feeds	963R
Feeds	984R

**Intelsat 702
177E**

Feeds	963R
AFRTS	973L (PowVu)
Feeds	984R
Space TV Sys	12.612H (MPEG)

**Intelsat 513
177W**

Feeds	963
Feeds	984

(513 Ku)

Service	RF Freq.
US Nets	10.980V
NBC	11.015V
Feeds	10.510V

Ku Services
Intelsat Ku band services shown here are boresighted to Japan and nearby Asia, have not been reported south of equator.

TDRS5 / 174.3W

Fuji TV	1305 Hz
BBC World	1163Hz MPEG

UPCOMING SATELLITE LAUNCHES

ApStar 2R (to 76.5E)/ October 10-15 launch
IndoStar 1/Cakrawarta to 106E (S-band) Oct 10
InSat 2E to 83.5E/ November/December
AsiaSat 3 to 105.5E December 12

**Intelsat 701
180E(W)**

TVNZ	964/Dmv 3000
TVNZ	972/Dmv
TVNZ	980/Dmv
TVNZ	988/Dmv
ABC/CBS	1010/ Vidiplex
Occ Vid.	1,020**
SCPC	1,032
SCPC	1,054 **
RFO Tahiti	1,105
SCPC	1,126
SCPC	1,136
World-net	1,175
Feeds	1,216
Feeds	1,254
NHK(e), NBC	1,270
SCPC	1,326
10 Oz MCPC	1,385 (PwRvu)
CNN USA	1,430
Baccar.	1,439 **

* RHC & LHC
** LHC only
e/ encryption

(701 Ku)

NHK	11.135H
CBS	11.475H
CNN	11.508H

LAOSAT 1 - (L-SAT-1) 1ST QTR
STARSAT 1 - JAN 25
BSAT 1B - MARCH
ST 1 - APRIL

AHTV - 3820V, 441K, 314 - 1578

Hei Long Jiang N 3834V, 4418, 314 - 1316

SatFACTS Pacific/Asian MPEG-2 Digital Watch: 15 October 1997

Bird	Service	RF/IF & polarity	# Prog channels	FEC	Msym
I703/57E	Sky News	4187/963RHC	1	3/4	5(.632)
		4140/1010RHC	1	3/4	5(.632)
I704/66E	CFI	4055/1095 RHC	4	3/4	27(.500)
PAS-4/68.8E	Walt Disney	3982/1168 Hz	2	3/4	6(.620)
	ART, RAI	3970/1180 Hz	2	3/4	5(.632)
	BBC World	3994/1156 Hz	1	3/4	6(.620)
	TVSN	3743/1407Hz	1	3/4	21(800)
	CCTV	3716/1434 Hz	6	3/4	19(.850)
Thaicom 78.5E	UTV	3920/1230 Hz	6TV (#1)	3/4	27(.500)
	UTV/MCOT	3880/1270 Hz	6TV (#2)	3/4	27(.500)
Measat 1/91.5	India Bouquet	12284/12346Vt	10+TV?	7/8	30(.000)
As2/100.5E	European Bouquet	4000/1150 Hz	6TV, 12 radio (#3)	3/4	28(.125)
	Hubei TV (HBTV Main)	3854/1296 Hz	2	3/4	4(.418)
	Hunan TV (SRTC)	3847/1303 Hz	1	3/4	4(.418)
	Guandong TV (GDTV)	3840/1310 Hz	1	3/4	4(.418)
	Inner Mongolia TV Zizhiqu	3828/1322 Hz	2	3/4	8(.397) (1-China) (2-Mongolia)
	APTV London	3800/1350 Hz	1	3/4	5(.631)
	BBC Radio	3793/1357 Hz	?	?	?
	WTN Jerusalem/ London	3790/1360 Hz	1	3/4	5(.631)
	WTN London	3786/1364 Hz	1	3/4	5(.631)
	WTN HK	3775/1375 Hz	1	3/4	5(.631)
	Star Bird Athen	3760/1390 Hz	1	3/4	10(.000)
	Liaoning TV (Service 2)	3734/1416 Hz	1	3/4	4(.418)
	Jiangxi TV (JX Sat TV)	3727/1423 Hz	1	3/4	4(.418)
	Fujian TV (SETV)	3720/1430 Hz	1	3/4	4(.418)
Quinghai TV Zenghou	3713/1437 Hz	1	3/4	4(.418)	
Henan TV Main	3706/1444 Hz	1	3/4	4(.418)	
As2/100.5E	Sky Racing	4020/1135Vt	3TV	1/2	18(.000)
	Hallmark	3940/1210Vt	1TV	2/3	26(.650)
	STAR TV (Hong Kong)	3900/1250 Vt	5TV (#4)	3/4	28(.100)
	"QQQ" China (Shaanxi)	3813/1337 Vt	1, 1 Radio	3/4	4(.418)
	Guangxi GXTV	3806/1345 Vt	1, 1 Radio	3/4	4(.418)
	Rebar TV Taiwan	3785/1365 Vt	5TV (#5)	3/4	18(.000)
	Myawady TV	3766/1384Vt	1TV	7/8	5(.080)
	Star TV HK	3740/1410Vt	6 TV	3/4	28(.100)

Interoperable Receivers (a)
unknown
N163/17X/2X, HS-100C
Pv9223 (CA)
Pv9223
Pv9223, N163/2X, HS-100C
HS-100C, Philips, probably others (some chs now CA)
HS-100C, Philips, probably others (some chs now CA)
Philips
DMV, HS-100C, Gng, N163, /17X/2X, N2000, P400(b), P500, Pn520/630, Sk888
HS-100C, N163/17X/2X, N2000, Ph3950/11
HS-100C, N163/17X/2X, N2000, Ph3950/11
HS-100C, N163/17X/2X, N2000, Ph3950/11
HS-100C, N163/17X/2X, N2000, Ph3950/11
DMV, HS-100C, N163 /17X/2X
(Receiver format unknown)
DMV, HS-100C, N163/17X/ 2X
DMV, HS-100C, N163/17X/ 2X
DMV, HS-100C, N163/173/2X
N2X
HS-100C, N163/17X/2X, N2000, Ph3950/11
HS-100C, N163/N17X/2X, N2000, Ph3950/11
HS-100C, N163/17X/2X, N2000, Ph3950/11
HS-100C, N163/17X/2X, N2000, Ph3950/11
HS-100C, N163/17X/2X, N2000, Ph3950/11
Pace DVS-211 (CA)
HS-100C, N2X (tests, erratic)
Pace DVS211(CA), DMV, N163*/17X+/2X
HS-100C, N163/17X/2X, N2000, Ph3950/11
HS-100C, N163/17X/2X, N2000, Ph3950/11
Pv9223 (CA) [Video inverted?]
HS-100C (limited hours operation)
Tests/sometimes Indovision

Bird	Service	RF/IF & Polarity	# Prog. channels	FEC	Msym
(As2/100.5E)	STAR TV Hong Kong	3700/1450 Vt	8TV (#6)	3/4	28(.100)
C2/113E	Tests	11.500Hz	multiple TV	7/8	26(850)
	Star Indovision	3500/1650Hz 3580/1570Hz	20 TV (#7)	7/8	26(.850)
	Indovision	3460/1690Hz	6TV	7/8	21(000)
	MegaTV	3780/1370Vt	5TV (#8)	3/4	27(.500)
	Tierman-1/PTV	3926/3935Hz	1TV	3/4	4(880)
Thaicom 1/120E	Thailand terres.	4120/1030Vt	6TV	2/3	27(.500)
APIA/134E	AXN	4060/1090Vt	4	7/8	28(.330)
API/138E	Reuters	3732/1418Vt	1TV, data	3/4	5(.632)
Palapa C1/150.5	Indovision	4117/1033Hz	10TV	7/8	26(.850)
Optus B3 156E	Galaxy	12.438Hz 12.373Hz	20+TV (#9)	3/4	29(.473)
	Optus Vision	12.564Hz 12.626 Hz	16TV, 8 radio (#9A)	3/4	29(.473)
Optus B1 160E	Aurora (MPEG test)	12.377Hz	5+ TV (#10)	2/3	30(.000) [27(.500)]
	ABC Exchange	12.540Hz (.550, .560)	1 each	3/4	6(.980)
PAS-2 169E	Telstra Bendigo	12.300Vt	3TV, 2 radio (#11)	1/2	10(.138)
	MTV Asia	12.605Hz	8TV	1/2	22(.490)
	Hong Kong PowerVu	4148/1002 Vt	8TV (#12)	2/3	24(.430)
	NBC Hong Kong	4093/1057 Vt	7TV (#13)	3/4	29(.473)
	JET Singapore	3962/1188 Vt	2TV (1-Ntsc, 2-Pal)	1/2	13(.740)
	ESPN (USA)	3860/1290Vt	4TV, 2 control	7/8	26(.470)
	CCTV China PowerVu	3716.5/ 1433.5 Vt	3TV (#14)	3/4	19(.850)
	TCS Singapore	4183/967 Hz	2TV (#15)	1/2	6(.620)
	ITJ-Japan	4.174/976 Hz	1 TV	3/4	5(.632)
	AAR-ART/RAI Int	4153/997 Hz	3TV (#16)	3/4	5(.632)
	PAS-2 feeds	3940/1210 Hz	2TV(NTSC)	2/3	6(.620)
	California PowerVu	3901/1249Hz 12425Vt	8TV (#17)	3/4	30(.800)
	Satcom 1-6	3862/1288Hz	6TV	7/8	19(.465)
	Disney/Aust.	3804/1346Hz	1TV	5/6	21(.093)
	Discovery Singapore	3776/1374 Hz	7TV (#18)	3/4	21(.093)
	Hong Kong #2	3718/1432 Hz	7TV	2/3	20(.607)
I702/177E	AFRTS	4177/973 LHC	8TV, 12 radio & data (#19)	3/4	28(.000)
	SPACE TV Systems	12.612/1312 Hz	13TV, 11 radio (#20)	3/4	26(.694)
I701/180E	TVNZ Gannet (feeds)	4195/955RHC 4186/964 4178/972, 4170/980, 4162/988	1 TV typical each	3/4	5(.632)
	Canal Plus	4091/1059LHC	1TV (?)	3/4	34(.368)
	10 Australia	3765/1385RHC	5TV	7/8	29(.900)

Interoperable Receivers (a)
Pace DVS-211 (CA), N163/17X/2X
Pace DVS-211 (CA)
Pace DVS-211 (CA)
Pace DVS-211 (FTA?)
N2X/DVS-211(CA)
N2X (occasional use)
unknown
unknown
N163/17X/2X
same as 3580 C2
Gng, P400, P500, Pn520, + Pn630, Sk888 (c)
(when testing is over, only IRDs with CAM)
N163/17X/2X, Pv9223, HS-100C
Pv9223, HS-100C, N2X (FTA)
Pv9223, N2X (some Pv CA)
Unknown- Asia beam only
Pv9223, HS-100C(*), N2X* (some FTA)
HS-100C, Gng, N163/17X/2X, P400 (b), P500, Pn520, Pn630, Sk888
Pv9223 (CA)
Pv9223 (CA)
Pv9223, HS-100C, N163/17X/2X (FTA)
Pv9223, HS-100C N17X/2X (FTA)
HS-100C
Pv9223, N17X/2X, (continues FTA)
Pv9223, N2X, HS-100C
Pv9223, HS-100C (*) N17X/2X (*), (some FTA)
Pv9223 (CA)
Pv9223 (CA)
Pv9223, HS100C, N2X (occasionally Ch. 2 FTA)
Pv9223, HS100C
Pv9223 (CA)
Pv9223, HS100C, P2X (All but 1 CA)
DMV, N17X, 2X (not all channels hot at all times)
Sagem ISD 2050 (?) (CA)
Pv9223 (CA)

SatFACTS MPEG-2 Digital Watch: 15 October 1997 ♦ Support Data

Receivers: (a) By our definition, a receiver is deemed "fully interoperable" when it will turn on and routinely receive the service in question with no persistent glitches, no special tricks (such as loading software from an external source). Receivers in abbreviated listings are those that have shown these qualities for the transmission service listed. There is a time lag of up to 30 days after introduction of new receivers before sufficient data is accumulated for inclusion here. Nomenclature: DMV is DMV/NTL 3000 (a professional model receiver); HS-100C is Hyundai HSS-100C, designed for China; Gng is Grundig DTR1100 (manufactured by Panasat - see SF#31, p. 15); N163 is Sweden sourced Nokia 9500 S with version 1.63 software; N17X is German/European Nokia "d-box" software modified for C-band use; N2000 is Nokia sourced IRD created for Chinese SCPC market with AsiaSat 2 and Intelsat manual search software; N2X is May/after 1997 version of 9500 S; Pace DVS-211 is Indovision (+ Sky Racing) CA only receiver also used by Sky on As2; Ph3950/11 is rack mount Philips DVB IRD created for China SCPC project; P400 is Pace DGT400; P500 is Pace DVR500; Pn520 is first version Panasat (July 1996); Pn630 is latest version Panasat (February 1997); Pv9223 is PowerVu by Scientific Atlanta; Sk888 is Skandia DigiSkan. (b) P400 (DGT400) will only work with EBB (et al) when it has not been over the air enhanced (upgraded); (c) SK888 will not work with conditional access (pay) services.

Bouquets: 1) Thailand UTV: (1) CNN, (2) TTV, (3) ESPN, (4) HBO, (5) Ch. 5, (6) itv; 2) Thailand UTV/MCOT: (1) Ch. 9, (2) Discovery, (3) Ch. 3, (4) TNT, (5) Star Sport, (6) Ch. 7; 3) **European Bouquet.** (1) Deutsche Welle, (2) MCM, (3) RAI International, (4) RTVE, (5) TV5 Paris, (6) [when operating] Deutsche Welle special programme channel with MediaNet VBI included [lines 10-15, requires DMV M2/Pro/Txt board inserted in 3000 series receiver]; Radio (1) DW#1 (stereo), (2) DW#2 (stereo), (3) DW#3 (stereo), (4) YLE (left) & RCI (right), (5) SRI (l) & WRN (r), (6) REE, (7) DW#1 (stereo), (8) DW#2 (stereo), (9) DW#1 (stereo), (10) NN RA6, (11) NN RA8; 4) **STAR TV Hong Kong.** (1) Sky News London, (2) Sports Contribution, (3) Channel [V] International, (4) Star Movies Japan [NTSC], (5) Star Plus Japan [NTSC]; 5) **Rebar Taiwan.** (1) "U1" [movies], (2) "U2" [news], (3) "U3" [sport, cartoons, general entertainment], (4) "Rock TV", (5) Tests [FTA]; 6) **STAR TV Hong Kong.** (1) Channel 6, (2) ESPN Contributory, (3) Racing Ch., (4) Star Movies SEA, (5) Star Chinese, (6) NBC, (7) CNBC, (8) Sky News, (9) VIVA Cinema; 7) **Indovision.** (1) HBO Asia, (2) STAR Movies SEA, (3) Film Indonesia, (4) MGM Gold, (5) ESPN Asia, (6) STAR Sport, (8) Channel 'V' International, (9) Channel 'V' Asia, (10) RCTI, (11) STAR +, (12) Discovery, (13) STAR Movies and NBC Asia, (14) Phoenix Chinese, (15) CNN, (16) BBC World, (17) CNBC, (18) Cartoon + TNT, (19) Preview 1, (20) Preview 2; 8) **MegaTV.** (1) CNNI, (2) Discovery, (3) ESPN Asia, (4) HBO Asia, (5) Cartoon + TNT, [(6) MGM Gold, (7) Cinemax (6-7 may not be operating)]; 9) **Galaxy.** Presently 20+ programme channels. 9A) Optus Vision tests of 16 programme channels, programming decisions to be finalised; 10) **Aurora.** (1) SBS NT, (2) SBS NE, (3) SBS, (4) Sky News, (5) ABC WA; 11) **Telstra Bendigo.** (1) Imparja, (2) ABC, (3) ABC radio, (4) Imparja radio, (5) ABC TV FTA; 12) **Hong Kong PowerVu.** (1) CTN 1, (2) CTN II, (3) TVBI Hong Kong, other feeds [NTSC], (4) **Ad-hoc 1 PA** [PAL], (5) **Ad-hoc II** [NTSC], (6) **ABN**, (7) CTN II, (8) CTN; 13) **NBC Hong Kong.** (1) CNBC, (2) CNBC Mandarin A, (3) NBC Asia, (4) colour bars, occasional feeds, (5) CNBC Mandarin B (6) NBC "2" Asia/Taiwan, (7) Colour bars, "future" use; 14) **CCTV China.** (1) **CCTV4**, (2) **CCTV3** [(3) **CCTV 9**, (4) **CCTV4**, (5) **CCTV5**, (6) **CCTV8**, (7) **CCTV tests**]; 15) **TCS Singapore.** (1) **TCS Test**, (2) **TCS Default** [repeats channel 1]; 16) **SCPC3.** (1) ad-hoc use, (2) AAR/ART, (3) RAI International; 17) **California PowerVu.** (1) **CMT**(NTSC), (2) **CBS feeds**, others including CTV Canada (NTSC), (3) [Greece] Antenna 2 (NTSC), (4) **EWTN** (NTSC) global Catholic radio, ch. 2, (5) **BBC World** (NTSC), (6) **Bloomberg Financial** (NTSC), (7) Golf Channel (NTSC), (8) ESPN (NTSC); 18) **Discovery.** (1) Disc. Aust/NZ, (2) **Disc. default**, (3) Disc. Japan, (4) Disc. SE Asia, (5) Disc. Taiwan, (6) Disc. Philippines, (7) Disc. China; 19) **AFRTS.** (1) News, Sports [ACII, CW, RR, 9.6 kbps, TV], (2) Spectrum [Urban, 64 kbps], (3) AFN Pacific [TV], (4) Channel 1 - Mirror [TV], (5) AFN Korea [contingency, 1.536, TV], (6) The Jim Lambert Test Channel [!!!], (7) EPG, voiceline, (8) EPG, u/i voiceline, (9) AFN Atlantic [Top 40, HR, NPR, TV], (10) AFN Americas [Top 40, TV], (11) AC1, (12) Country, (13) Adult Rock, (14) NPR [US National Public Radio], (15) Urban, (16) Pure Gold, (17) Top 40, (18) Hard Rock (19) Contingency.; 20) **SPACE Systems** (in loading order). (1) P904[Exxtasy], (2) P200(CA), (3) P201(FTA), (4) P202(FTA), (5) P203(barker), (6) P204(barker), (7) P205 (barker), (8) P206(CA), (9) P207(FTA), (10) P208(barker), (11) P501(audio/data), (12) P502(audio/data), (13) P503(audio/data), (14) P504 (audio/ data), (15) P505(audio/data), (16) P506(audio/data), (17) P507(audio/data), (18) P508(audio/data), (19) P509(audio/data), (20) P510 (audio/ data), (21) P511(audio/data), (22) P3801(CA), (23) P3802(CA), (24) P7777(CA). NOTE: Listings in **bold face** are PowerVu transmissions that are typically (but not always) FTA (free to test). Note 2: At pretime, all SPACE TV System services except Formosa TV News are CA, but status changes weekly.

MPEG-2 DVB RECEIVERS: [Data here is believed accurate; we assume no responsibility for errors in this volatile area!]

DMV/NTL 3000. Skandia Electronics Pty Ltd (tel 61-3-9819-2466)

Grundig (Gng) DTR1100. Av-Comm Pty Ltd (tel 61-2-9949-7417)

Hyundai-TV/Com. Model HSS-100C is officially available from Pacific Satellite (tel 61-7-3344-3883) and Skandia Electronics (tel 61-3-9819-2466); Skandia offering "V3" with software chips that access all FTA services including PowerVu

Nokia 9500 S (V1.63). This version is no longer available although it had ability to identify Msym and FEC parameters of unknown carriers. (V1.7X) was a German language "d-Box" version originally imported by OPAC; it functioned with the same parameters as the V1.63. (V2.X; 2.233/e3, 2.034 and others perhaps not yet identified) are current (after June/July) software versions that allow virtually unlimited stacking of bouquets and programmers and for at least the 2.233 version also allows limited red menu correction of NTSC glitch (see SF#36, p. 6). Sources known include: AV-COMM Pty Ltd (Tel 61-2-9949-7417); Pacific Satellite (61-7-3344-3883), SCITEQ (61-8-9306-3738); Telsat (64-6-356-2749). AV-COM also has macro-command IR remote that expedites 'red menu' operations for e3 version 9500 S. (see SF#36, p. 32).

Nokia "d-box" (V1.7X) suitable for C-band use. Instructions, on-screen prompts may be in German. No longer available.

PACE DVS-211. Officially available only through Sky (racing) Australia (Bob Pankhurst tel 61-2-9451-0888).

PACE DGT400. Through Galaxy offices, Australia.

PACE DVR-500. Bay Satellite TV Ltd. (tel 64-6-843-5296); also supplied by NBC to affiliates.

Panasat 520 (Pn520). OPAC Pty Ltd (tel 61-2-584-1233); no longer available.

Panasat 630 (Pn630). Antares Satellite (61-7-3205-7574); no longer available

Panasat 635. A notation - The Panasat 635 will not be released except in South Africa

PowerVu D9223. Scientific-Atlanta (Sydney) Tel 61-2-9452-3388; BaySat (tel 64-6-843-5296), Telsat (64-6-356-2749)

SAGEM ISD2050. SAGEM SA, Mrs. Salima ALAOUI (tel 33-1 40 70 63 63)

Samsung VS-2000 (ver 1.31). Pacific Satellite (tel 61-7-3344-3883)

SK888. Skandia Electronics Pty Ltd. (tel 61-3-9819-2466)

WITH THE OBSERVERS

Observer **George Scarfe** (Grange, SA) in response to our request for reports concerning eastern region Australia reception for PAS-4 notes: With Paraclipse 12', 17 degree Chaparral Sidekick, the following PAS-4 service in descending order of signal levels - Sony TV, TNT, ATN, CNNI. Discovery may be the strongest of all, but is in B-MAC so cannot resolve.

Those reporting Japanese SCPC ITJ (4274/976H, Msym 5.632 and FEC 3/4) include George Scarfe, Grange (SA) with Hyundai HSS-100C.

Those reporting CNBC from Palapa C1 at 150.5E include: **Francis Kosmalski** (Auckland, NZ: P2 on 3.7m Orbitron).

Summary reports for Intelsat 180E (now I701): Francis Kosmalski (Auckland, NZ: 10% improvement); **R.L. Bubner** (Broken Hill, NSW: now to P4 on 2.3m); **David Leach** (NSW), RFO up 3dB.

Erratic Aurora platform test service reported by **John Pogson** (Wyong, NSW) - off the air September 19-23.

Trevor Sorensen (Tambellup, WA) reports B1 NET 9 feeds (1425V) have moved to 1220H; PAL analogue continues.

Colin Frost (Stafford, Qld) using a Orbitron 12', has been able to get lock on VTV1 from Measat at 91.5E. He has moved his 1.6M Ku dish to PAS-2 in anticipation of "more interesting programming." He also notes, "EM TV has been running without encryption for several weeks but with my 12' dish it is often unmatchable because of the increased inclination."

Garry Cratt (Balgowlah, NSW) and others report Palapa C2's MEGA TV goes into and out of conditional access (3780V, Msym 27500, FEC 3/4) on what seems to be an erratic schedule.

Gorizont 27 at 96.5E now has TV Azerbaijan on 3875RHC, SECAM with audio on 7.50. Gorizont 25 at 103E now has ART on 3875RHC, replacing VRK which was there previously; PAL and audio on 7.0. Gorizont 28 at 90E has added two audio sub-carrier services: Radio Majak (3875LHC and 7.0 MHz) and Radio Nostalgiya on 3675LHC (8.4 and 8.58 MHz).

Several observers report The Golf Channel, PAS-2 California bouquet (programme channel 7) as free to air for a day or two at a time. This service is expanding to the Philippines and perhaps the brief FTA status is somehow connected.

Imparja, Alice Springs based NT telecaster serving northern Australia, has made public its plans for conversion to MPEG

AT PRESS DEADLINE

EM TV has abandoned 142.5 and reappeared on AsiaSat 2 Horizontal 3765/1385 with audios still on 6.2 (programme) and 6.8 (radio). Signal is 2dB lower in level than ERTU or WorldNet (same polarity) but still heaps better than when last "seen" on inclined orbit Rimsat/Gorizont. At press-time, Videocrypt off.



CBS Network (USA) is one of two vidiplexed services fed on I701 (180), 4140/1010RHC

digital. In a September letter, **Corallie Ferguson** (CEO) writes in part:

"*Imparja is planning to start a digital service early next year (1998). It will be carried on the PanAmSat (PAS-2) satellite (Ku). For around 2 months we will operate jointly on Optus (in B-MAC) and PAS-2. By mid-February, we plan to cease B-MAC transmissions.*

"*Imparja plans to use a system developed by Telstra, based upon equipment manufactured by Scientific-Atlanta. The ABC, on the other hand, has announced a five year contract with Optus for delivery of all of their remote area HACBSS services. ABC will be using a digital service on Optus called Aurora which is technically closely aligned to the Galaxy Pay TV system.*

"*Hopefully, (HACBSS) viewers will not require two dishes and two decoders. Negotiations are underway with ABC to place their service on PAS-2 along with Imparja (and GWN - editor).*

"*One of the reasons why Imparja is moving to PanAmSat is the possibility of forming an alliance with a Pay TV operator providing National services. Recent developments in digital technology allow a single carrier to transmit as many as 6 different TV programmes simultaneously.*"

So GWN and Imparja are now officially planning their own PAS-2 (Ku) service, and looking for a pay TV operator to share their transponder. GWN had previously stated that it was "reserving space in the digital bouquet" to accommodate ABC as well. ABC's decision to go with Optus obviously could

WITH THE OBSERVERS: Reports of new programmers, changes in established programming sources are encouraged from readers throughout the Pacific and Asian regions. Information shared here is an important tool in our ever expanding satellite TV universe. Photos of yourself, your equipment or off-air photos taken from your TV screen are welcomed. TV screen photos: If PAL or SECAM, set camera to f3.5-f5 at 1/15th second with ASA 100 film; for NTSC, change shutter speed to 1/30th. Use no flash, set camera on tripod or hold steady. Alternately submit any VHS speed, format reception directly to SatFACTS and we will photograph for you. Deadline for November 15th issue: November 3 by mail (use form appearing page 34), or 5PM NZDT November 4th if by

fax to 64-9-406-1083.

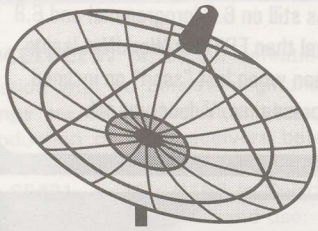

AV-COMM SATELLITE TV EQUIPMENT

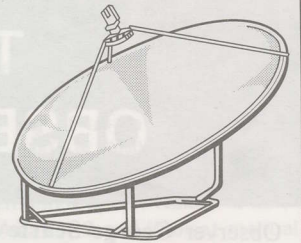

INTRODUCING THE DYNASAT 300P RECEIVER

*Plus Australian sales tax if applicable

ONLY
\$775*

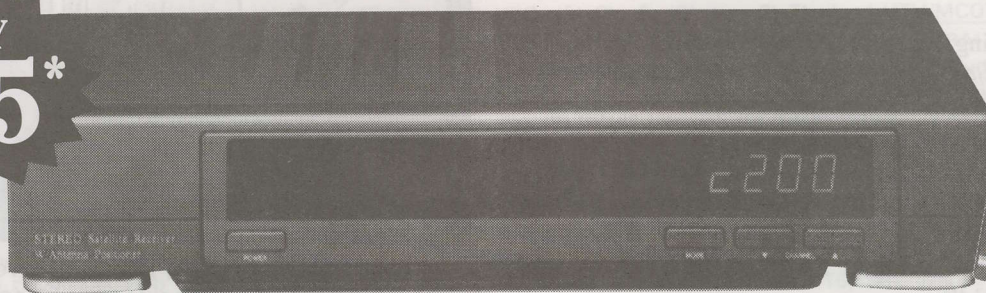

CAT #R1152

LOW THRESHOLD RECEIVER WITH DUAL AXIS POSITIONER

FEATURES

- 200 CHANNELS ••▶
- DUAL AXIS POSITIONER ••••▶
- DUAL INPUTS ••••▶
- SCART & RCA OUTPUTS ••▶
- DUAL BANDWIDTHS ••▶
- FREQUENCY SCAN ••••▶
- 14/18V SWITCHING ••••▶
- 20 STEP THRESHOLD EXT ••••▶

BENEFITS

- PRE-PROGRAMMED WITH 90 CHANNELS VIEWABLE FROM AUSTRALIA & 40 FROM NEW ZEALAND.
- FOR INCLINED ORBIT SATELLITES
- ALLOWS DUAL DISH/BAND OPERATION
- MAXIMUM INTERCONNECTION FLEXIBILITY
- SUITABLE FOR HALF TRANSPONDER OPERATION
- SEARCH FOR UNKNOWN FREQUENCIES
- USE DUAL POLARITY OR WIDEBAND LNB
- PRESET THE EXACT THRESHOLD FOR EACH CHANNEL

**We reserve the right to improve product performance without notice.*

AV-COMM PTY. LTD.

DIRECT IMPORTER ACN 002 174 478
PO BOX 225, BALGOWLAH 2093

TEL: 61 2 9949 7417 9948 2667

FAX: 61 2 9949 7095

VISIT OUR WEB SITE AT

<http://www.avcomm.com.au>

✓YES GARRY, Please send me more info...

Name: _____

Address: _____

_____ P'code: _____

Phone: _____

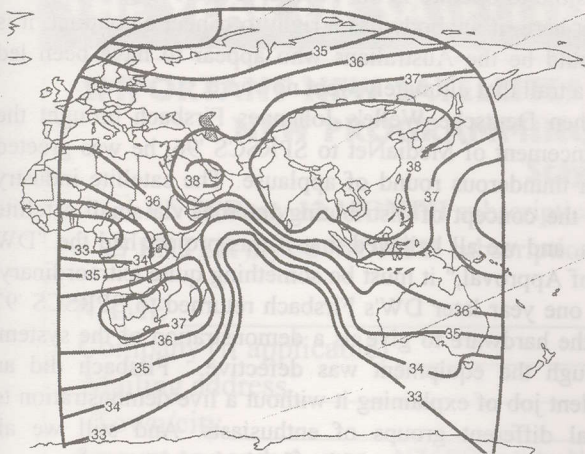

NEXT TARGET - Apstar 2R heading for 77E could be useful for Australian viewers (scheduled launch was October 10-14).

Vertical Polarization Transponder Set

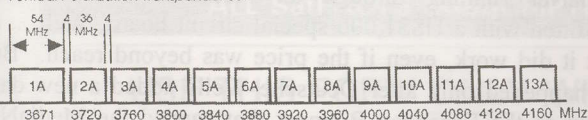

Horizontal Polarization Transponder Set

prove to be a hardship for HACBSS viewers if ultimately they are forced to invest in two dishes and two IRD units to continue receiving either Imparja or GWN along with their existing ABC service. (Thanks to George Scarfe for the update.)

SPACE TV's Intelsat 702 package (177E) went encrypted September 12th and remains so at presstime with the exception of occasional FTA status for The Formosa News Channel.

Mark Long (Thailand) and others report Palapa C2 (113E) has been testing its Ku band coverage; 11.500H using Indovision C2 C-band 3580(H) bouquet as a test source (26850, 7/8). Don't expect to get a lock with a pre-programmed PACE 200/211 receiver however; its memory parameters are for C-band and the same service coming back on Ku is "flipped" upside down!

Sky Channel (Australian racing) has made a slight move to 4020 (V) from their previous 4015; further evidence that Nine Network is preparing this transponder to accept a new SCPC occupant (such as EM TV).

Audio fans will appreciate "Southern Fried Rock" on subcarriers of 5.4 and 5.6 1701, 180E, 3876.5 RHC. The video here is encrypted, KLOS-FM Los Angeles is not! Programming format includes live rock concerts, music from 60s, 70s and 80s. (**Stu McLeod**, Hastings, NZ)

Garry Cratt (NSW) reports Madagascar TV on Gorizont 27 (96.5E) and 3843/1307RHC with audio on 5.8 (radio audio 7.8; video is SECAM).

Sky (NZ) Sport 1 service is planning addition of TAB/Trackside horse racing audio (only) on new subcarrier (12.545 GHz) around mid-December. ESPN audio has been running there in the clear for several weeks.

Sky News (London/Australia) via MediaNet on PAS-2 Ku, reported September 12.287, has now terminated.

SCI TEQ

PTY LTD

ACN 009 235 090

Trade supplier of

- Nokia Receivers
- Orbitron Dishes
- ADL Feedhorns
- Gardiner LNB's
- other satellite accessories

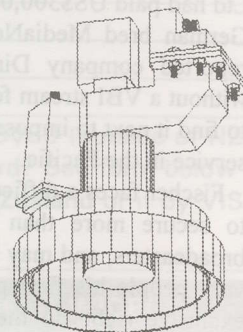

Phone: +61 8 9306-3738

Fax: +61 8 9306-3737

<http://www.omen.com.au/~pmerrett>
33 Kentia Loop, Wanneroo
WESTERN AUSTRALIA 6065

NOT COMING TO A NEWSAGENT NEAR YOU

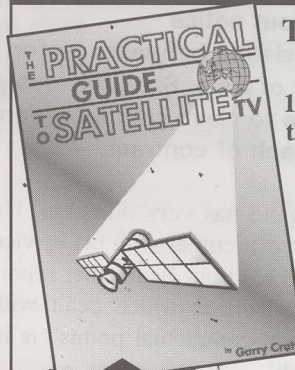

THE PRACTICAL GUIDE TO SATELLITE TV

116 easy to read pages, explaining the history, theory, operation and installation of *HOME SATELLITE TV* systems.

121 explanatory photos, tables, graphs and diagrams.

46 pages of satellite orbital data, transponder loading, footprints for every satellite covering Australia and neighbouring countries and comprehensive glossary of terms.

NEW!

AVAILABLE NOW - \$39

AV-COMM PTY LTD

A.C.N. 002 174 478

198 Condamine Street,
Balgowlah NSW 2093

Tel: (02) 9949 7417/9948 2667

Fax: (02) 9949 7095

<http://www.avcomm.com.au>

✓ YES GARRY, Please send me 1 x Practical Guide to Satellite TV priced at \$39 + \$5 p&p (NZ \$8 p&p) Australian \$ only

Credit Card

Signature _____

Name: _____ Expiry Date: / /

Delivery Address: _____

P'code: _____ Phone: _____

Nice Guys To Do Business With-

In September we reported Net On Air (Asia Pacific) Pty Ltd had paid US\$300,000 for the exclusive right to distribute German bred MediaNet in the Pacific and Asia. We also reported company Director Peter Fischer's concerns that without a VBI stream for his MediaNet service, he was going to find it next to impossible to implement the VBI distributed service in the Pacific.

Fischer faces a difficult, uphill battle. He has not been able to secure more than token interest from Australian TV broadcasters, and may in fact be facing competition from the very people his firm paid US\$300,000 to for the so-called exclusive rights to the service. More about that at a later time.

Shortly after SatFACTS for September reported our concerns for the future of MediaNet in the Pacific, Fischer received a communiqué from M. Wiegand of Germany's MediaNet. With indirect reference to the September SatFACTS report, Wiegand wrote to Fischer on September 23:

Dear Mr. Fischer,

Just now a newspaper article was presented to me titled with 'The Downside of MediaNet'. The therein listed informations are mainly based on contractual points, the passing on represents a serious contract violation. By all means this kind of behavior we cannot accept, therefore we terminate without notice the license agreements consisting between us for Australia, the USA and parts of Asia. Simultaneously we particularly reserve for us to claim compensation because of clear breach of contract.

Interpretation? MediaNet's Wiegand has very thin skin. He was not pleased to read about the difficulties with his service in the Pacific. If you go back and read our September report (page 32) you will see that the portion which dealt with possible "informations ... based on contractual points" is in paragraph two. There we reported:

"Actually, we paid US\$300,000 for the exclusive rights to market MediaNet not only in the Pacific and Asia, but the United States as well."

Wiegand and MediaNet GmbH are grasping at straws if they believe disclosure of how much the Australians paid for their exclusive right is a violation of contractual terms. We could have just as easily have quoted two separate sources in Germany who told us the very same information. In other words, what was paid for the rights is not a state secret and Wiegand and his crew have been telling people in Germany this same information for months.

Wiegand and the MediaNet GmbH have managed to grab US\$300,000 for rights to a system which to date has been

impossible to operate in the Pacific. If there is going to be a lawsuit here, if anybody has a right to cancel a contract, it is or should be the Australians who appear to have been led down a trail that ultimately went nowhere.

When Deutsche Welle's Johannes Firsbach brought the announcement of MediaNet to SPRSCS '96, he was greeted with a thunderous round of applause. The satellite industry loved the concept of distributing Internet via small satellite dishes, and we all believed that if this project had the "DW Seal of Approval," it must be something quite extraordinary. Then one year later DW's Firsbach returned to SPRSCS '97 with the hardware to give us a demonstration of the system. Although the equipment was defective, Firsbach did an excellent job of explaining it without a live demonstration to several different groups of enthusiasts. And still we all believed the system was viable, if unlucky.

Then two weeks later in Sydney at the Australian cable and satellite show, a second scheduled demonstration also failed. Boy - talk about bad luck!

By April, one Australian firm told us they actually had MediaNet running through an A\$3,800 NTL receiver retrofitted with a US\$1,000 special circuit board. Well ... at least it did work, even if the price was beyond reach. But this happened only after Deutsche Welle added a new data stream to the European Bouquet that carried the MediaNet stream to the special circuit board. By now it was becoming obvious that the representations originally made about MediaNet's low cost application to home satellite terminals had been somewhat misrepresented. Just how badly we would not know for several additional months.

In the midst of all of this Peter Fischer and partners coughed up US\$300,000 to have the exclusive distribution right to the system "out here." That was their bad luck.

Mr. Wiegand does not sound like the sort of person we would like to do business with. How he sorts out his problems with Fischer and partners will probably depend upon which side has the largest legal budget. In the meantime, when somebody pops up claiming they can deliver Internet via satellite to "low cost terminals" we grab our hindside and run as rapidly as possible in the opposite direction.

There is another high glitter Internet access system brewing as we write these words. It is called ZakSat and early testing done by knowledgeable people in New Zealand and Australia is disturbingly reminiscent to MediaNet's trials and tribulations; *deja vu*. If you have been approached to get involved in the Internet via home dish business in the Pacific, our caution to you is to keep a tight grip on your cheque book until you see solid proof the system being promoted works and you are convinced the people behind it are reputable and will support the product. And understand this. Internet via satellite, no matter what it is called, is a one-way system. It allows fast downloading of materials (when it works properly) but does not allow the user to initiate requests nor interact except by a telephone (wireline) modem. As Mark Long exudes, *"This will be a wonderful service for people who live where existing telephone systems are unable to properly access Internet reliably or cost effectively."* True. But that is where it stops, for today. If your clients already have wireline access to Internet, they should be told "Not for you, mate." When a satellite dish will give two-way access to Internet, *then we'll be talking.*

THE YEAR OF SATELLITE EXPLOSION IN THE PACIFIC/ASIA!

IMPORTANT NEW SATELLITES ARE ANNOUNCED FOR 1998 and EARLY 1999. NEW PROGRAMMING VENTURES ANNOUNCED MONTHLY!

Stay tuned with SatFACTS!

- ENTER my 12 MONTH subscription to SatFACTS starting with November 15th issue (rates below)
 ENTER my 36 MONTH subscription to SatFACTS starting with November 15th issue (rates below)

NAME _____

Company (if applicable) _____

Mailing address _____

Town/city _____ Country _____

Amount to send: 1 year - NZ\$50 (inside New Zealand) / A\$90 (inside Australia) / US\$60 (outside of NZ and Australia) or 3 years - NZ\$120 / A\$210 / US\$150 if by cheque. **VISA** or **Mastercard**? See form below and return with order. Return to: **SatFACTS, PO Box 330, Mangonui, Far North, New Zealand** or if by VISA or Mastercard fax to 64-9-406-1083

ALL SatFACTS SUBSCRIPTIONS ARE SENT VIA AIRMAIL - WORLD-WIDE!

USE THIS FORM ONLY WHEN CHARGING ON VISA/MASTERCARD

Please charge my **VISA/Mastercard** as follows:

- ONE Year of SatFACTS MONTHLY (NZ\$50, A\$90, US\$60)
 THREE Years of SatFACTS MONTHLY (NZ\$120, A\$210, US\$150)
 SATELLITE TELEVISION: The Booklet (NZ\$10, A\$12, US\$10)
 One Year of COOP'S TECHNOLOGY DIGEST (NZ\$125, A\$125, US\$125)

Indicate charge card type: VISA Mastercard

Name (as it appears on **VISA / Mastercard**) _____

VISA/Mastercard Number _____

VISA/Mastercard expiration date _____

Instructions: If ordering by mail, return this complete (3-part) card or a copy of same (to **SatFACTS, PO Box 330, Mangonui, Far North, New Zealand**); if order by FAX, send full card as a single sheet to **64-9-406-1083**

SUPPLEMENTAL MATERIALS from SatFACTS MONTHLY: Order Form

- SATELLITE TELEVISION:** The Booklet. Excellent introduction to home dish ownership for the layman, including major contributions from the father of geostationary satellites - famed science fiction writer *Arthur C. Clarke*. The perfect tool to help the satellite system seller explain home satellite TV to the layman consumer. From SPACE Pacific. NZ\$10/ A\$12 / US\$10, airmail.
- COOP'S TECHNOLOGY DIGEST.** For the really serious enthusiast, investor, business person in satellite television and allied leading edge technologies. Ten issues each year, jam-packed with information you will not find anyplace else. "Coop" routinely culls more than 60 publications world-wide, terribly expensive newsletters, Internet and his hundreds of private contacts to keep you right at the leading edge of technology on the REAL changes underway in telecommunications. Conveniently issued near the **first of the month**, creating an excellent time-line-filler between the mid-month issues of SatFACTS. Now in the 5th year, airmail world-wide. Normally NZ/A/US\$250 per year - for SatFACTS subscribers special **50% discounted** price of NZ/A/US\$125.

OBSERVER REPORTING FORM - CONTEST ENTRY - Due Nov 5

- NEW programming sources seen since Oct 1st: _____
- Changes (signal level, transponder, programming content) in pre-existing programming sources since Oct 1st: _____
- OTHER (including changes in your receiving system): _____

NOTE: Please use P1 - P5 code when describing signal levels and receiver IF/RF settings.

Your Name _____ Is this contest entry? _____
Town/City _____
Make/size dish _____ LNB _____ Receiver _____
Bonus Word Entry: _____ on page _____

September BONUS WORD - Sassafras p.29 -

MAIL TO: **SatFACTS Monthly**, PO Box 330, Mangonui, Far North, NZ or fax 64-9-406-1083

YOU COULD WIN A PALCOM SL7900RP!

SatFACTS is giving away two (2!) top of the line super receivers - the PALCOM SL 7900RP and the DYNASAT 300P - to subscribers between October 1st and February! This is a MONTHLY CONTEST and you must REGISTER with us as a contest entrant. Complete this card to receive the full set of Contest Rules and join the fun. A DYNASAT 300P was given away October 5th - a new PALCOM SL 7900RP given away February 5th!

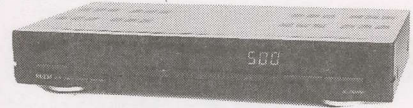

I AM A SUBSCRIBER TO SATFACTS - Please mail to me my SatFACTS Reader Contest Rules!

NAME _____
Company (if applicable) _____
Mailing address _____
Town/City _____

Return card to: **SatFACTS Monthly**, PO Box 330, Mangonui, Far North, New Zealand
of fax to us at 64-9-406-1083

SPRSCS '98 INFO PACK?

FULL INFORMATION PACKET DESCRIBING THE JANUARY 27 - 31
South Pacific Region Satellite & Cable Show - now available!

YES - Send details of SPRSCS '98 to ...

NAME _____

Company (if applicable) _____

Mailing address _____

Town/city _____



SPACE Pacific Ltd.
PO Box 30, Mangonui, Far North
New Zealand
Fax 64-9-406-1083

THE SHOW OF SHOWS

SPRSCS '98 / January 29-31 in Auckland, New Zealand

**WHERE ELSE - IN 3 JAM
PACKED DAYS CAN YOU -
LEARN THE SECRETS OF TUNING IN
DIRECT FROM USA**



NETWORK FEEDS?

LEARN THE TRICKS
OF GAINING ACCESS TO

HBO CINEMAX TNT

PAY TV PROGRAMMING?

UNRAVEL THE MYSTERIES
OF POWERVu, MPEG-2, AND
DIGICIPHER DATA STREAMS?

**REVEL IN THE EXOTIC WORLD
OF ADULT TV PROGRAMMING?**

REDISCOVER THE WORLD OF



**DO IT YOURSELF
MODIFICATIONS?**

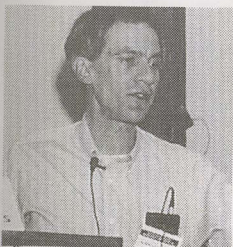

MEET HUNDREDS OF
ENTHUSIASTS
FROM ALL OVER THE
PACIFIC AND
ASIA AND ACTUALLY

talk with Dr Digital of the Pacific,
ROBIN COLQUHOUN?

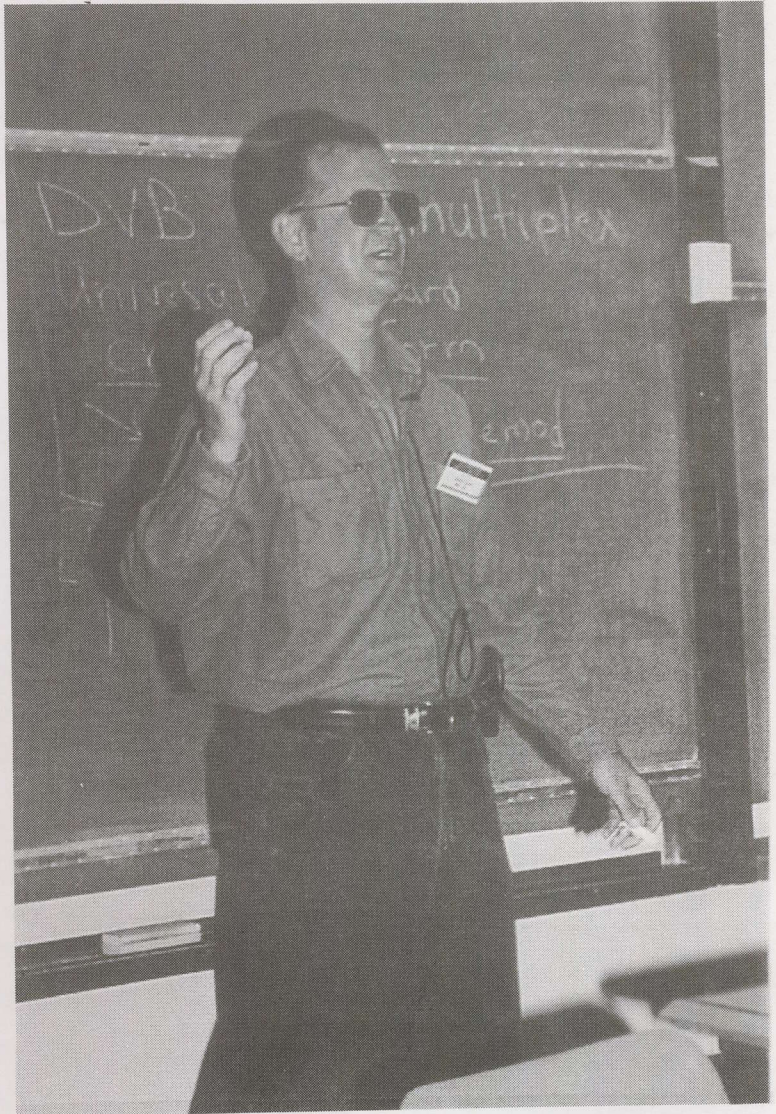

SERIOUS ABOUT YOUR SATELLITE TV?

SPECIAL two-day MARK LONG/SPACE *Satellite Installer
Certification Course* January 27-28 leads into the three day
SPRSCS '98 Event January 29-31!



FOR FULL INFORMATION and DATA PACK ... USE CARD TO LEFT

UNIDEN SATELLITE TELEVISION

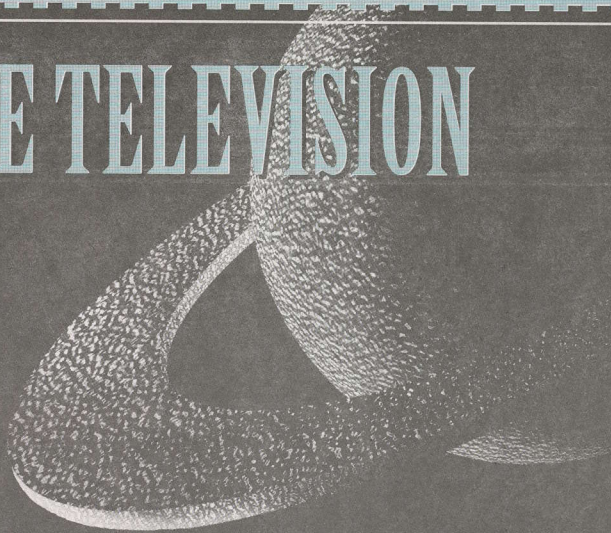

JUST IMAGINE...

Over thirty channels of free-to-air television from around the globe available throughout New Zealand, even in areas where present free-to-air or paid channels don't reach.

THIS IS NOT A DREAM, It's a reality. And it's available to your customers right now, with equipment costs that are probably a lot less than you would expect.

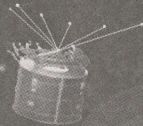

Uniden are about to launch their Satellite Television Package to dealers throughout New Zealand.

If you would like to find out how to profit from satellite television in New Zealand give Uniden a call.

After all, Uniden is one of the world leaders in satellite television technology.

UNIDEN SATELLITE TELEVISION

*Putting You Face To Face With
A World of Entertainment*

uniden®

a Clear Signal of What's Ahead

For more information Phone 0-9-273 8383 or Fax 0-9-274 0009

Uniden® is a registered trademark of the Uniden Corporation of Japan Ltd and is represented in New Zealand by Uniden (NZ) Ltd.