

Bob Cooper's

AUGUST 15 1997

SatFACTS

MONTHLY

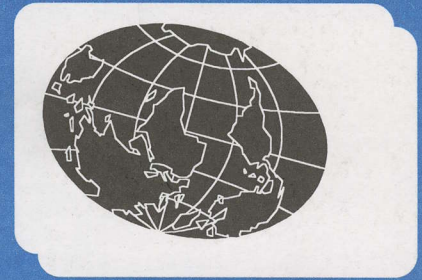

Reporting on "The World" of satellite television in the Pacific and Asia

IN THIS ISSUE

**SIDE BY SIDE
EVALUATION
HSS-100C/ 9500S/
D9223**

**MURDOCH:
MAD or
MAGNIFICENT?**

**1701 at 180E:
WHAT TO
EXPECT**

- ✓ Latest Programmer News
- ✓ Latest Hardware News
- ✓ Latest SPACE Pacific Reports
- ✓ Cable TV Connection

Vol. 3 ♦ No. 36

Price Per Copy:
NZ\$8/A\$9/US\$6



HOW MUCH PIE IN SKY?

Paraclipse[®]

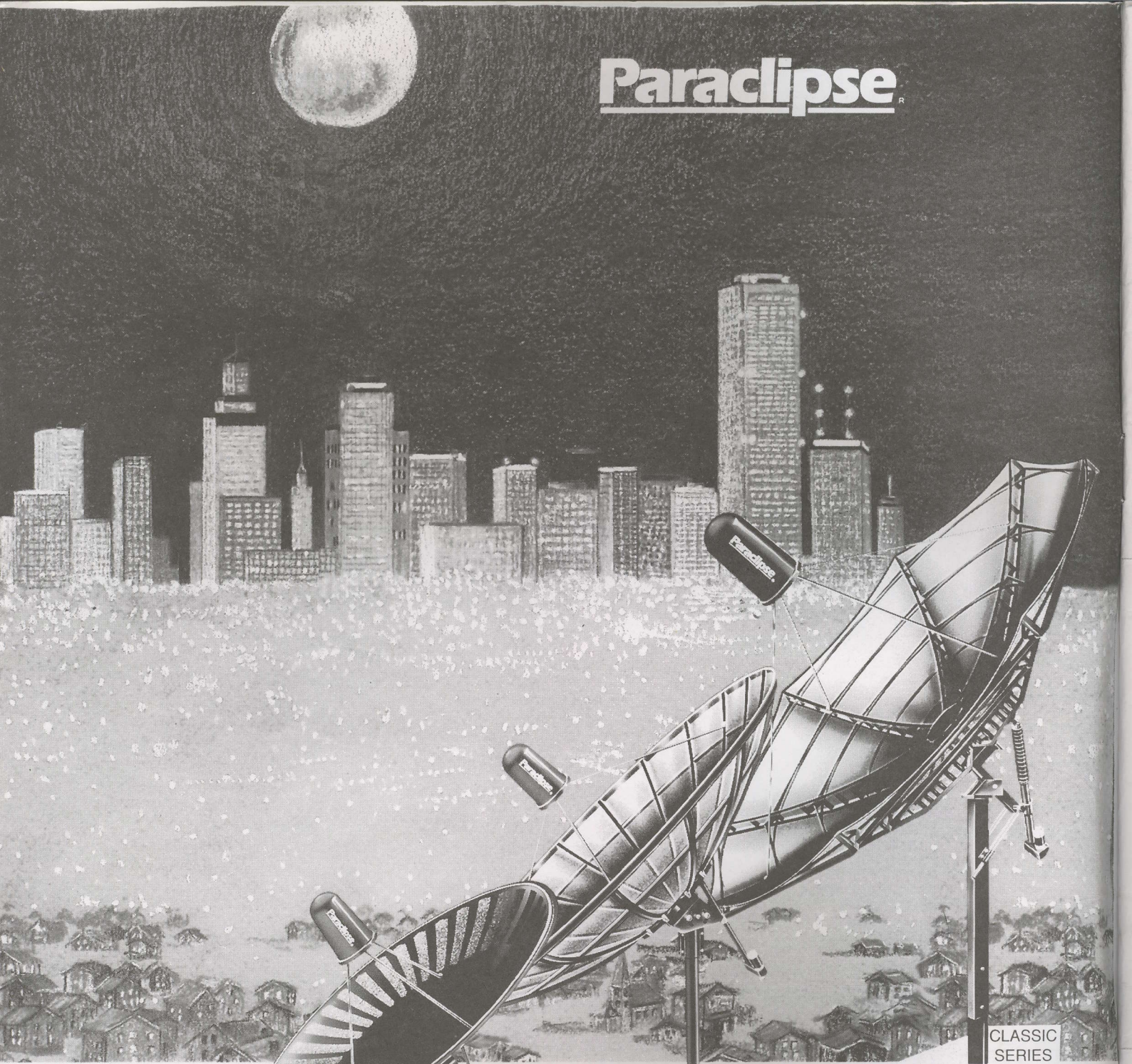

When quality, strength, and accuracy are your main requirements, **Paraclipse** antennas are your first choice.

HYDRO
SERIES

ECLIPSE
SERIES

CLASSIC
SERIES

Only **Paraclipse** offers such variety; four distinctly different series: the Truss-Ribbed Classic, the Courier Deliverable Eclipse, the Stretch Formed Hydro, the Commercial Patriot.

Every **Paraclipse** model sets the industry standard in its class, worldwide.

Distributed in Australia by
SKANDIA ELECTRONICS Pty. Ltd.
183 Burwood Rd, Hawthorn, Melbourne
Tel 61-3-9819-2466 * Fax 61-3-9819-4281
Level 1, 39 Terry St, Rozelle, Sydney
Tel 61-2-9555-2955 * Fax 61-2-9555-2455

Distributed in New Zealand by
BAY SATELLITE TV Ltd.
PO Box 3311, Napier
Tel 64-6-843-5296 Fax 64-6-843-6429

Paraclipse[®]

HIGH PERFORMANCE ANTENNAS

★ MADE IN AMERICA

Paraclipse Inc.
2271 29th Avenue East, Columbus, Nebraska USA 68601
Telephone: (402) 563-3625 Fax: (402) 564-2109

SatFACTS MONTHLY

ISSN 1174-0779

is published 12 times each year (on or about the 15th of each month) by Far North Cablevision, Ltd.

This publication is dedicated to the premise that as we enter the 21st century, ancient 20th century notions concerning borders and boundaries no longer define a person's horizon. In the air, all around you, are microwave signals carrying messages of entertainment, information and education.

These messages are available to anyone willing to install the appropriate receiving equipment and, where applicable, pay a monthly or annual fee to receive the content of these messages in the privacy of their own home. Welcome to the 21st century - a world without borders, a world without boundaries.

Editor/Publisher
Robert B. Cooper (ZL4AAA)
Office Manager
Gay V. Cooper (ZL1GG)

Reaching SatFACTS

Tel: 64-9-406-0651

Fax: 64-9-406-1083

Mail: PO Box 330

Mangonui, Far North

New Zealand

Subscription Rates

Within NZ: \$50 p/y

Australia: AV-COMM Pty Ltd, PO Box
225, Balgowlah, NSW 2093

61-2-9949-7417

Elsewhere: US\$60 p/y

All copies sent via airmail fast post
world-wide

ERRATA

SatFACTS Copyright 1997 by Robert B. Cooper; any form of copying is a violation of our international copyrights. Advertising rate sheet available upon request.

COOP'S COMMENT

The good news: Scientific Atlanta's latest D9223 software option seems to do virtually any non-CA service listed in our Digital (MPEG 2) Tuning Parameter tables (p. 26, 27). *The bad news:* SA Sydney is charging a US\$525 premium for this software version D9223.

Their logic: There is, they claim, a "real list price" of US\$1,820 on a D9223. And that US\$1,295 that we have all been paying from day one? *Subsidised.* By whom? PanAmSat, they say. How does that work, and why?

There is purported to be an agreement between PanAmSat, the satellite operator, and Scientific Atlanta, the PowerVu uplink provider, to discount the D9223 receiver for any one using the D9223 on the PowerVu service feeds of PAS-2.

This discount (to US\$1,295) is supposed to be a special consideration made by Scientific Atlanta when they were awarded the PanAmSat contract to provide digital (albeit PowerVu) uplink services to PAS-2.

How's that, again?

In the beginning, shortly after God created earth - but not very much after - Scientific Atlanta created PowerVu and offered it to PanAmSat as their "basic digital service." Someone at PanAmSat is supposed to have said, about PowerVu, "Gee - that is a very nice digital service but it is expensive and we folks at PanAmSat would like to see programmers encouraged to use our digital platform. Can't we do something to make PowerVu more attractive?"

To which, it is noted, Scientific-Atlanta came back and said, "Tell you what we are gonna do - you give us the exclusive PanAmSat digital contract, and for every one buying a receiver that will be used with a PanAmSat PowerVu digital feed, we'll knock a big chunk off the receiver price - kind of a reward for having chosen PowerVu."

And so PanAmSat and Scientific Atlanta walked down the aisle together, for better or worse, richer or poorer. But in their prenuptial agreement, S-A spelled out a special situation. If someone came to them and ordered a receiver for something other than PanAmSat PowerVu reception, the price would be \$1,820 - not the "PanAmSat subsidised \$1,295." PanAmSat could care less - for their clients they believed they had won a concession (a US\$525 or 40% discount) and with this PanAmSat could tell programmers they wanted to talk into using their satellite - "Look here - and for your clients using our PowerVu feeds, we'll throw in a \$525 discount on the receivers; each and every receiver." A win-win situation - S-A looked good, PanAmSat looked good, and S-A got the \$1,295 per receiver it originally intended to get. Hey - if you cannot afford to discount something and you want the sale badly enough - simply jack up the price by 40% and then offer a 40% discount. Used car salesmen employ this sales gimmick frequently - size up the customer, tell him an inflated price, then put your arm around the customer's shoulder and whisper into his ear - "Hey, I like you. For you, I will knock off \$525."

So why come back now and stick anyone who wants the new "does MPEG-2 software" for an extra US\$525? The best of logic applies here. If you want software that allows the receiver to access something other than PowerVu, you must be planning to use the receiver for something other than the PowerVu services. So you should not be entitled to the "special PanAmSat PowerVu" price discount. Which means - you pay \$525 extra for the new software. Even if you are after NBC on PAS-2 (because, while it may be on PAS-2, it is not PowerVu).

So what happened to the promised \$80 software upgrade? SA changed their mind. If you want your present PAS-2 subsidised receiver upgraded to the new "Kosmalski Software" (SF#35, p. 29), plan on US\$525 plus shipping charges. If you want a brand new D9223 with "Kosmalski" included, plan on US\$1,820 - not \$1,295.

You have got to get up pretty early to beat those sharpies from SA. And if there was ever a logical reason to encourage software hackers to dump a receiver's software as Internet "shareware" - this is it.



August 15, 1997

In Volume 3 ♦ Number 36

ROBIN COLQUHOUN does side by side
testing of HSS-100C, 9500 S and D9223 - p. 6

(Rupert) MURDOCH:

MAD or Magnificent? -p. 12

1701 at 180E -p. 18

Departments

Programmer/Programming Update -p.2; Hardware/Equipment Update -p. 4;

SPACE Notes: Selling 'Safe' Sex -p. 20;

CABLE Connection - Redistributing Sex on TV -p. 22;

SatFACTS Orbit Watch -p. 24; MPEG-2 Tuning Parameters -p. 26;

Digi Notes Reference Information - p. 28

With The Observers -p. 29; At Sign-Off (Tid Bits) -p. 32

-ON THE COVER-

There is a man who lives in Beverly Hills, California amongst the movie moguls, stars and starlets who is rated the world's tenth richest man. The Los Angeles Business Times estimates his net worth at US\$3,200,000,000. He was borne in Australia, made his first real money in the UK and became a US citizen so he could make more money.

His name is Rupert Keith Murdoch and "Sky" is his game (p. 12).

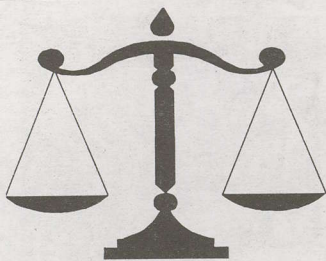

To Porn or Not to Porn - That is the Question

"Bare breasts in SatFACTS? I am shocked!"

Nick Stride, National Business Review, Auckland
Our job is simple - to make certain you are totally informed about developments within the satellite TV world. If you want to know more than we are telling you about Exxtasy, go to <http://www.xtc-com.com> through your local ISP.

Wild Card Feeds

"While tuning around PAS-2 on Sunday 13 July at 8.14NZT on 3.7456 GHz there was a FTA NBC network feed of US Women's Open Golf. From time to time those PAS-2 (or other) test cards come to life with some very interesting programming!"

Todd Johnson, Plimmerton, NZ

Indeed. In Europe and North America where there are hundreds of operating satellite transponders, dozens of these are devoted to "occasional use" by programmers who have a sudden, unplanned need to get material from point A to B. Some of these are "scheduled" to the extent they appear at the same time, week after week while others are catch as catch can. In the trade these are known as "wild card feeds." SF would publish listings for those that are semi-scheduled if readers will supply the relevant information (i.e., satellite, transponder, polarisation, day of the week, time and format).

Build It?

"I plan to either build or purchase a satellite dish to be able to receive foreign television, mainly Australian. Could you send me some information about how to build a dish, the best materials to use, the best size? And perhaps a catalogue of feedhorns and the receiver equipment?"

Brent Allen, Waimumu, Gore (NZ)

Step one: Order the Mark Long / SPACE Satellite TV Handbook (US\$75, A\$102, NZ\$105 from SPACE Pacific, PO Box 30, Mangonui, Far North, NZ). Step two: Read it, carefully, from cover to cover. Step three: Contact the firms advertising here in SatFACTS to obtain catalogues and data sheets on equipment on offer. Step four: If you decide you REALLY do want to build your own dish, order "The Nelson Parabolic TVRO Manual" which takes you step by step, part by part through building your own 3+ metre dish (through SatFACTS at US/A/NZ\$20).

Cards and Letters From People We Don't Even Know

"I listened with interest to the interview with Robert Cooper on Radio Netherlands's Media Network; can you advise cost of SatFACTS to here in the UK?"

D.J. Hunt, Brighton, UK

\$60 US or equivalent world-wide, airmail!

PROGRAMMER PROGRAMMING PROMOTION

UPDATE

AUGUST 15, 1997

Indovision digital service packages are being offered to subscribers in countries surrounding Indonesia proper at the following annual rates: Visi Multi - 29,000 Rp (US\$176); Visi Sinema - 59,000 Rp (US\$358); Visi Sinema Plus - 59,000 Rp (US\$358) and Visi Super Sinema - 69,000 Rp (US\$418) The Pace DVS-211 IRD is sold separately at US\$1,000 or if the subscriber wishes to trade-in the older style SA CDE-2000 decoder, US\$775. TAV (tax) of 10% is on top of these charges. How much is that in say Australian \$? 29,000 Rp equals A\$210 and that gets you ESPN, Star Sports, CNN, BBC World, CNBC, Channel [V] International, Discovery, TNT/Cartoon, NBC, Star Plus and CITRATV (3). For detailed report on programming costs, see Coop's Technology Digest for July 30.

Score one for our side. SF June carried two page lament by Australian dealer Pietro Casoar deploring RAI International "rule" that keeps Italian soccer from EBB RAI feed. Surprise. As SF was going to press (July 7) and again on July 14th, RAI-EBB did carry live soccer to the Pacific and Asia. Nobody is 'fessing up' to a rule change but the soccer is making plenty of Australian-Italians happy they purchased their EBB dish systems!

EMTV is telling viewers it will switch to AsiaSat 2, but will not convert to MPEG "at this time." There are some significant transponder changes coming.

GMA, Filipino domestic service (Palapa C2) distributed largely FTA (but with an hour or so each day analogue encrypted) is telling applicants for analogue decoders, "We will compress our signal in a digital format and become totally 'encrypted' by the end of this year." What is not said, that GMA will move off of C2 to new Mabuhay satellite at same time. Check their transponder with an analyser - if you find a pair (not one) MPEG signals in the passband, enter 3935 and 3926 into your Nokia 1.63 and see what you get (answer on page 27).

Mega TV service on Palapa C2, FTA in MPEG-2 for several months, converted to colour bars on all but CNNI channel in mid-July. Hyundai receivers are now excluded because they don't have a CAM (see pages 8, 10 and 11 here). Mega is a terrestrial (MMDS) operator in Malaysia, claims 110,000 subscribers to their terrestrial network and charges US\$18 per month for that delivery system. Future of Palapa digital feed? Unknown.

PerfectTV is getting more perfect. Japan's first serious pay to view service now claims 260,000 subscribers.

Star-Plus has been renamed Star World on most feeds; AsiaSat 1 (soon to be 3) southern beam remains with the old name.

MTV Asia now claims more than 50 million homes with customised feeds for individual countries featuring local talent and music. The feeds you might see on Palapa C2, PAS-4 and Apstar 1 each have different content.

Formosa TV now has pair of 27 MHz analogue transponders on PAS-2, Ku, operational; first with news service, second with general entertainment. Distribution is in FTA mode and should be widely seen throughout Asia. Reports?

MTV Asia appeared PAS-2 Ku, apparently Asian beam, 12.585Vt with 8 programme channel bouquet (Msym 29.100, FEC 3/4) August 1; reports?

Sky (NZ) added Orange Channel in 1/2 transponder Videocrypt format Optus B1 August 4; 12.516 GHz (Sky Sport 12.545).

Phone number OOPS: Sky (Australia) Horse racing channel should be 61-2-9451-0888, not as incorrectly listed here last month; Bob Pankhurst.

HYUNDAI

Connect to the World...

HYUNDAI Digital DBS Set-Top Box

HSS-100C
MPEG-2 (MP @ ML) & DVB compliance

PROVEN PERFORMANCE

Power Vu
DVB Compliance
FTA

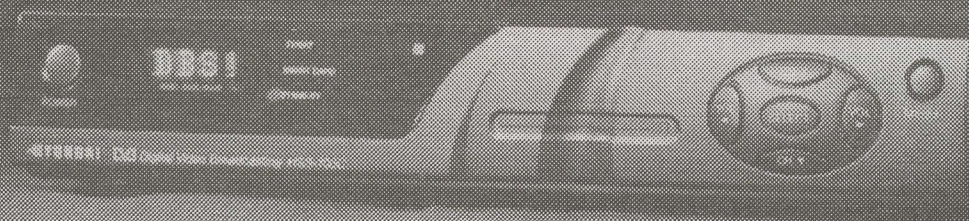

Distributor - Australia & New Zealand

Skandia

Skandia Electronics Pty Ltd

Victoria: 183 Burwood Road Hawthorn 3122, Australia
Telephone: (613) 9819 2466 Fax: (613) 9819 4281

NSW: Level 1, 39 Terry Street, Rozelle 2039, Australia
Telephone: (612) 9555 2955 Fax: (612) 9555 2455

- QPSK demodulation
- CD Audio quality (MPEG-1 Layer 1 & 2)
- Access up to 500 virtual channels
- Supports the aspect ratio both 4:3 and 16:9
- Easy-to-navigate electronic program guide

Filipino Services

"My wife wishes to see Filipino television other than GMA on Palapa C2. I notice you mention The People's Network and RPN-9 - both using GI 1.5 MPEG. Can anyone advise me how I can purchase this receiver and subscribe to these services? Also - what about Viva Cinema for the Philippines in the Star bouquet?"

Ron Ryan, Rochedale South, Qld
fax/phone 61-7-3219-9897

All of the Filipino network services now spread over C1, PAS-2 (which includes CBN) are likely to migrate to Mabuhay (Agila 2) when (or if) it successfully launches later this year. GMA has announced it will "go digital" when it moves off of C2, an indication of planning now underway. RPN-9 and The Peoples Nets are not interested in DTH subs, CBN on PAS-2 will accept DTH subs but the bureaucracy is formidable and the GI DSR 1500 receiver more than A\$3,000.

Unhappy Contestant

"You keep changing the rules in your reader contest. reference the first letter of the monthly mystery word. A few of your local subscribers have mentioned that they won't send in their entry forms or they don't know what to look for. Could you correct this in future issues, please? On a more positive note, keep up the good work as this is a great magazine and very helpful."

Steve McManaway, Napier, NZ

Talk about cutting off your nose to spite your face! OK, don't send in your entries - hey, we are giving away free satellite receivers and if you don't want to send in a monthly entry because you can't keep up with the rules, that's your problem! The rules say you have three different ways to enter each month: Way one - send in the card each month from the back of the magazine completing the name, address and satellite equipment lines. *That's one entry.* If you also fill in an observation line (a report of something new you have seen), *that's two entries* (you have just doubled your chances to win). Now, buried in each issue is a hard to find, tricky BONUS WORD as explained in the rules every entrant has received. Find that word, and, fill in your name/address/equipment AND supply a report for the month and - BINGO - and you now have SEVEN entries for that month. Be a total non-participant and someone else will certainly walk away with the Dynasat or Palcom receivers. There is nothing that says you HAVE to find the mystery, BONUS word each month. Just your name/address/equipment constitutes an entry. In fact, the first winner (Philip Spora, announced in the June issue) only submitted a single entry for the month drawn. Reporting new observations (which is the point of the exercise) doubles your chances to win; finding the bonus words gives you five extra entries that month. Hey - lighten up, it's us, not you paying for these receivers! (Oh yes - we checked all entries to date; Australians as a group find the mystery word 323% as often as New Zealanders. Make of that what you will.)

Indian?

"Any hope of Indian programming?"

N. Sinha, Hoppers Crossing, Victoria, Australia
Yes- Sony Entertainment TV possibly! (see p. 32)

HARDWARE EQUIPMENT PARTS

UPDATE

AUGUST 15, 1997

Espano IRDs? Not this month, probably not next. Factory pre-production samples shipped to Australian distributor Antares came up shy in the tuner sensitivity department. The 'front end' problem is being resolved but all initial shipments to Antares are delayed until they are satisfied the receiver is a quality performer.

Optus satellite feeds are being uplinked using DiviCom (USA) MPEG-2 DVB hard and software.

Matra Marconi Space is building new digital uplink for digital BSKyB that will provide as many as 200 separate TV programme channels to subscribers.

Thaicom 2 has been renamed 2A at 120E; 10 C-band and 2 Ku-band transponders on board and operational. **Thaicom 4**, to be co-positioned with 2A, is scheduled for first half of 1998. If '4' is designed similar to 3 (now at 78.5E), this could be a major signal location for Australia, NZ and Pacific. C-band polarisation should be vertical.

Japanese BSAT 1a tested at 122E and was handed over by Hughes to owners July 31 at 110E replacing BS 3B. The HS376 craft has NHK, WOWOW and Hi-Vision on board, observers report enlarged coverage to Korea, Taiwan and China.

AsiaSat 3, a high powered Hughes 601 format satellite, still plans November launch by Russian Proton to 105.5E from Baikonour, Kazakhstan Cosmodrome.

PAS-8 for 166E is being reconfigured to make 12 Ku-band transponders available to Australia, a smaller number of these for NZ as well. Launch date remains elusive - "Sometime after middle of 1998" is most often quoted.

PACE DVS-211-GP2 of DVS-200 receiver family is latest version being shipped by Pace into Asia for Indovision, Star TV and Sky (Australian racing channel) service. Receiver comes out of the box pre-loaded with parameters for all of the above and more but requires authorised smart card that is customised for each service, to function. SF is testing this IRD, full report in September.

PACE DSR200 FTA receiver has appeared in Europe for free to air market there at around US\$600 consumer price. Same unit has been in stock at Skandia Electronics since June.

BSkyB has announced consumer price of US\$327 for 200 channel capable digital TV receiver system package to be offered in UK after April 1998. BSKyB has ordered one million receivers through four suppliers: Amstrad, Grundig in partnership with Hyundai, Matsushita and of course Pace. The receiver price is being subsidised by BSKyB and will only apply when consumer also purchases some minimum amount of programming at the same time (for additional cost). On the matter of FTA-access in any News Limited receiver product, the answer is "no." A spokesman for BSKyB tells us, "Sky is not in the business of supplying access to other (European) broadcasters, even free to air services." So don't be expecting any Pace supplied products for any Murdoch service to do anything but the Murdoch services (see p. 12, here).

COB is the latest acronym. It stands for "Conditional [Access Module] On Board" and it means conditional access is built-in at the factory, not "slide-in" (as in a module) in the field. All Pace DVS-211 family receivers are "COB."

NO such thing as a "free d-box." D. Morris, Bangkok following up our p. 4 report in July, got this response from Germany: "When you purchase a d-Box in Germany, you make a contract for 2 years. You pay DM1188 and have two years free (DM49.50 x 24 months). After that you give the d-Box back or continue paying at that rate. If you elect to keep the d-Box but don't want service, they will charge you DM1250. If you refuse to pay for the box or return it, they will switch it off." Seems fair enough.

ADL

BECAUSE PERFORMANCE IS ALWAYS YOUR FIRST PRIORITY

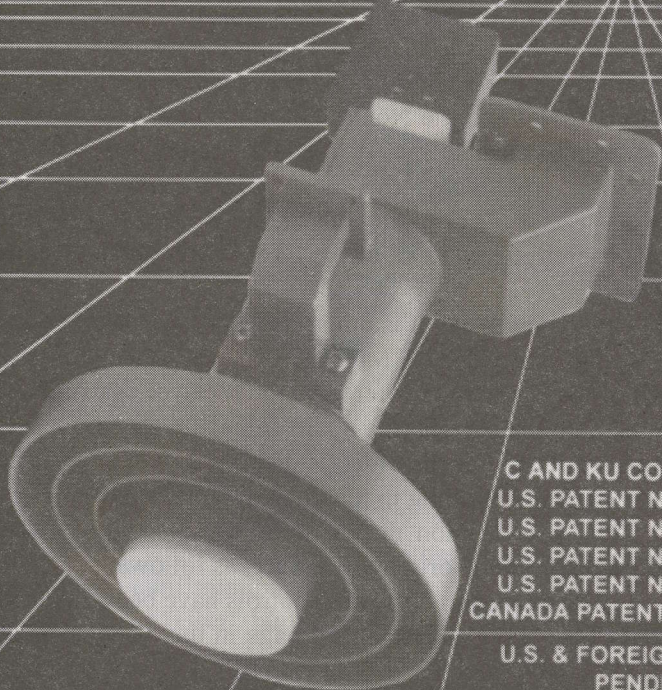

RP3-CKU/ International
Adjustable Scalar Ring Feed
with Extended C Band

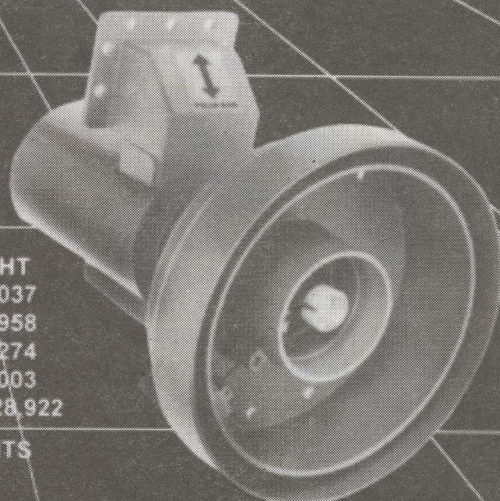

RPI-CKU Feed

C AND KU CO-BORSIGHT
U.S. PATENT NO. 4,903,037
U.S. PATENT NO. 5,066,958
U.S. PATENT NO. 5,107,274
U.S. PATENT NO. 5,255,003
CANADA PATENT NO. 1,328,922

U.S. & FOREIGN PATENTS
PENDING

ADL HYBRID MODING CIRCULAR POLARIZED INTELSTAT FEEDS WITH EXCLUSIVE T.I. REJECTION



RP1-CP400

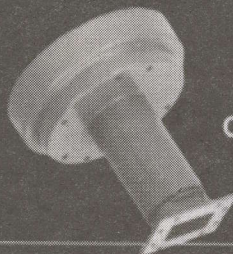

CP-300



CPOR-100

- C BAND LINEAR & CIRCULAR • C/KU LINEAR & CIRCULAR • KU 12 GHz FEEDS
- INTELSTAT 4 GHz CIRCULAR • ARABSAT S BAND FEEDS
- OPTIONAL: CO-BORSIGHT S BAND

2216 AGATE COURT, UNIT B, SIMI VALLEY, CALIFORNIA 93065 • (805) 526-5249 • FAX (805) 584-0634

ROBIN COLQUHOUN EVALUATES HSS-100C, 9500S and D9223

"Which receiver should I buy? Which is the best? Which one will give me RAI with soccer? Can I get Aussie football with one of these from here in Thailand?"

Word that observer Francis Kosmalski had somehow talked SA into modifying his D9223 with the latest version software resulted in my asking Francis to bring his unit to my home so I could check it out on something other than the PAS-2 services. I have been hearing claims about SA software for nearly a year and frankly I was curious that Kosmalski (or anyone else) had been equipped by SA itself with any software that would grant them unrestricted access to non-PowerVu free to air (FTA) services. I connected the Kosmalski receiver to a variety of C and Ku-band dishes and explored the sky from 100.5E to 169E - and I was sufficiently impressed to hand carry my own D9223 with me to Australia on a scheduled trip. If they could modify his - they could modify my own.

I can report that once back in New Zealand with my own trusted D9223, it was soon apparent that SA knew how to do the same thing at least twice; my receiver was the mirror image in performance to the Kosmalski machine. What follows is a critical comparison of the new software ("Kosmalski Version" - editor) Scientific Atlanta D9223, the Hyundai HSS-100C, and the Nokia 9500S (version 2.233(4) - also sold in Europe as the Mascom 9200S). With several weeks to "play," my own familiar signal levels connected to my own test and monitoring equipment, there was the luxury of time to properly evaluate the weakness and strengths of each of these presently popular receivers.

If you are looking for an absolute set of side by side test comparisons, you will find it here. If you expect me to come to a reasoned conclusion as to "which is best," you will be disappointed. All can be improved.

PowerVu-Plus D9223

Yes, it will access every service you find listed in FTA format in this issue's Digital Tuning Parameter tables. In truth, there are a handful of MPEG services which both the Hyundai and the Nokia will not access - for reasons not totally clear to me. If this is a contest to see which receiver will access the most programmers, this unit wins easily - primarily because it also gives you glitch-free access to all of the FTA PowerVu services as well.

That is not to say it is otherwise a perfect receiver. Nit picking first: On FTA MPEG-2 services, once you have all of the parameters entered so the receiver can find and lock onto the service, the audio comes up approximately two seconds after the video is displayed. Not a big deal - but worth mentioning in the interest of being complete.

The new version makes some unexpected software changes from the original software, as follows:

- 1) The coms port software controls have been changed
- 2) They have added a third page in the installer menu for "Search and Find." This page asks for prompts and/or allows you to:
 - a) Turn search on or off
 - b) Define search (frequency only, FEC only, frequency and FEC)
 - c) Set the upper frequency limit of search (i.e., L band 1450 MHz)
 - d) Set the lower frequency limit for search (i.e., 950 MHz).

Both upper and lower can be set to whatever frequency range you wish; an example: 1000 upper and 980 lower which confines the search to the 20 MHz between those

ROBIN COLQUHOUN - Not Your Average Boy Scout

I was not terribly impressed with Robin when we first met. I suspect he liked me even less. When our discussions turned into arguments - which was often - I usually hung up on him, discourteously. It took several years for our friendship to develop, each slowly accepting the other for what we were and recognising that neither of us was likely to change to suit the other. Robin reminds me of a fellow named Robert Coleman, a man living in rural South Carolina who in 1978 took a \$10 surplus Bell Telephone "TD2" microwave unit and turned it into an elegant satellite receiver on his kitchen table using parts from Radio Shack, his boy scout knife and a 35 watt soldering iron. Robin worries that so-called experts (which he is quick to say he is not) often miss the obvious. The world needs more Colemans and Colquhouns because they keep the

rest of us honest.

(Bob Cooper)

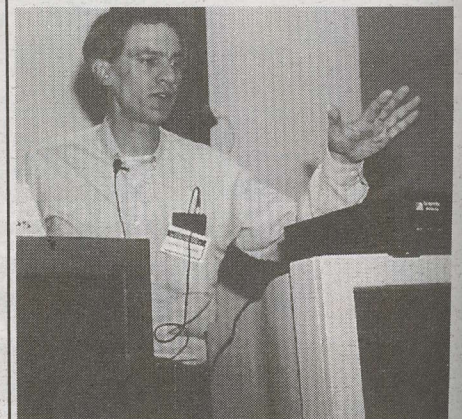

Colquhoun at SPRSCS '97

QUICK SUMMARY - HYUNDAI HSS-100C - NOKIA 9500S - SCIENTIFIC ATLANTA D9223

Model	Does NTSC?	Does FTA PowerVu?	Does SCPC?	Does MCPC?	Does Search & Find	14/18V switching?
HSS-100C	Yes	Yes	Yes	Yes	No	Yes
9500S	Yes with glitches	Yes in PAL, glitches in NTSC	Yes	Yes	Yes	Yes
D9223	Yes	Yes	Yes	Yes	Toy mode only	Only in MPEG

two points. To begin the search function, you toggle "on." Then:

1) Decide what type of search you will do. You have to tell the receiver in advance either the frequency (or frequency range) to search (supplying it with the FEC and Msym), or ask it to find the FEC (but supplying it with the correct frequency and Msym), or, ask it to find the FEC and frequency (after telling it what the Msym is in advance). In other words, if you don't know the Msym in advance, you cannot do a search.

2) Set upper and lower frequency limits. (If you wish to scan through the entire 500 MHz L-band IF, you can. But you probably won't want to - as we shall shortly explain.)

3) Push the keypad "YES" button which will cause the receiver to "store" your entry. The monitor screen will come back with "data saved" in the upper right hand corner as a confirmation.

Now push "User" button which will take you back a page in the menu. At this point you are half way into the search routine having told the receiver that "yes" you do wish to search and you have chosen one of the search parameters (such as "frequency only") and you have defined the "frequency range" you wish scanned.

Back into the main installer page menu, enter the parameters that fit your chosen search category. If you are scanning a range of frequencies (such as 980 - 1000) you must now enter the FEC and Msym as you normally would on the installer page. This done, use the "next" button to move the cursor down to the word "find." At this point it says "Off" after "Find."

To engage the Search Operation, go to the channel up/down keys at the lower left front of the receiver and press either the up or down button one time. The "Off" will change to "On" and the search is underway.

If you are scanning a frequency range, the installer menu screen will roll (indicate a changing frequency). If between the lower and upper frequency limits it locates an MPEG-2 FTA bouquet that corresponds to the Msym rate you entered (and the FEC rate if you knew it in advance), the scanning will stop and the receiver will lock. Before you can view this bouquet you must push the "Yes" button to save the new parameters. The installer menu screen should now say "locked" next to the bit error rate (which during search says "search"). To

go from the installer menu to TV reception, follow the standard procedure:

1) (Having saved the new data by pushing "yes" and seeing "data saved" appear in the upper right hand corner)

2) Push "View" which will move you to "channel 0" in the bouquet

3) Use the channel up button (lower left) to go to channel 1 (and so on up through the bouquet).

Some notes. As long as you are in the installer menu, you can stop the search mode at any point within that search by simply pushing channel up/down one time. If you have defined a sizeable search area (such as 950-1450) and the search routine locates a transmission it recognises (locking), by pushing "view" you can exit search to investigate the reception.

I noted that you will probably not want to be searching over a wide frequency range. Here is why.

1) When search locates a signal that matches the entered parameters, locks, and you go to view, you cannot restart search to continue through the remainder of the defined IF window.

2) If you inspect carefully the tables appearing on pages 26 and 27, you will note that it is very unusual to have the same FEC and Msym rates in use by two or more services (the Chinese SCPC being an obvious exception).

To restart search, you must return to the installer menu and change some instruction. Assume you started with a search window from 950 - 1450 MHz. And you are on As2 horizontal having entered FEC 3/4 and Msym of (0)4.418. It begins at IF 950 and goes up until it locates Hubei TV at 1296 (MHz). There it locks, you push "yes" to save, "view" to look and then channel up to go from 0 to 1. Satisfied that it found and works on the first (lowest IF) Chinese SCPC, now you want to go higher to find the second Chinese SCPC.

The original "search window" entered was 950-1450. The receiver started at 950 and went up to 1296 before it located a "lock." *Ideally*, there would be a button or two to push to restart the search at 1296 and send it upwards in the IF band. Sadly, not possible. To restart, return to the installer menu and enter anew the frequency range to be scanned; 1300-1450 might be a good choice in our example. It will of course next find Hunan TV at 1303 -

HOW MUCH MUST YOU KNOW TO LOCATE A NEW SERVICE?

Model Receiver	Can locate if you know no parameters	Can locate if you know approx. frequency only	Can locate if you only know FEC	Can locate if you only know Msym	Can locate if you know FEC and Msym
HSS-100C	no	no	no	no	tedious frequency search
9500S	yes	yes	yes	yes	yes
D9223	no	no	no	yes	yes

followed by Guandong at 1310. The next Chinese SCPC is Inner Mongolia with FEC 3/4 and Msym of (0)8.397. With the normal Chinese SCPC Msym of (0)4.418 previously entered, it will not find Inner Mongolia at (IF) 1322 (because Msym [0]8.397 is different)..

There are other demands on you when using the D9223 in their search format.

1) Search only works from the DVB mode

2) The 14/18 volt switching will not work so if you have a polarisation switching LNBF or a dual feed with a coax switch, you cannot use them. Strangely, the 14/18 volt switching does work in the MPEG mode but as search only works from DVB mode - you cannot get there from here.

So given these shortcomings, why has SA elected to include this so-called "search mode" in the software at all? Beats me - at best it is a toy and certainly would be of no value to a commercial (cable, broadcast) user. A real search mode would allow you to either enter a frequency or a frequency span and the receiver would come back and tell you what the actual frequency is as well as the FEC and Msym rate for any bouquets located. Now that would be something to write about.

I still believe the D9223 is generally a good unit if you wish to monitor all of the technical data associated with DVB signals. And it is the only receiver out there, at least in the software version reviewed here, which gives you totally glitch free reception for all services, including of course the FTA PowerVu. The D9223 allows PAL signals to output in PAL, NTSC to output in NTSC. And in fixed PID mode, you can watch and listen to TV and separately receive a radio audio service simultaneously; no other can do this.

The Hyundai HSS-100C

This receiver has a built in fan which is a first for a consumer unit. It will view all DVB compliant free to air signals and all of the PowerVu FTAs with the exception of RAI/AAR-AART on PAS-2. It sees and passes through PAL to PAL and NTSC to NTSC. It has a minor problem when viewing NTSC signals - the audio (lip) synch is delayed. This is easily user corrected by pushing the remote control "pause" button (freezes the picture) and then "pause" a second time which brings the audio and video into lip synch. There is an exception to this: BBC World in NTSC PowerVu (FTA) will over time (typically one hour) simply lose audio output. You get it back by changing up or down one programme channel and then returning to the BBC: Bingo - audio restored. This would not be a suitable receiver for BBC World in a cable or SMATV environment because of this problem, however. (Of interest- the BBC service is the only one in the NTSC California bouquet which does not require you to push the pause button to get the lip synch working properly. BBC starts out in PAL, is converted to NTSC someplace in North America, and then added to the California bouquet for transmission on PAS-2. Apparently, in the data stream there must be a bit or two that sneaks through often enough to confuse the receiver about whether it is PAL or NTSC.)

Now, if there is any kind of "low level access control" in the data stream, the Hyundai cannot cope with the data stream and tells you "This channel is scrambled." For example, there was a period when the PAS-2 Ku feeds of ABC National and Imparja brought up the "This channel is scrambled" message when in fact the Nokia 9500S and the PowerVu were running just fine. I am not

AND THE EASE OF USE FOR EACH RECEIVER WITH MEMORY RECALL OF PROGRAMME CHANNELS

Model Receiver	Will memorise all parameters for any SCPC/MCPC bouquet located	AND allow direct selection of <u>any</u> bouquet from menu	Tells you on screen in menu identity of each programme channel located and memorised
HSS-100C	yes, but you must supply parameters	yes, but you must make separate list to associate memory channels with specific programme channels	no
9500S	yes	yes	yes
D9223	Only one comfortably, two maximum (see text)	no	yes but only one or two can be memorised

The Nokia Mediama^{ster} DVB 9500 S.

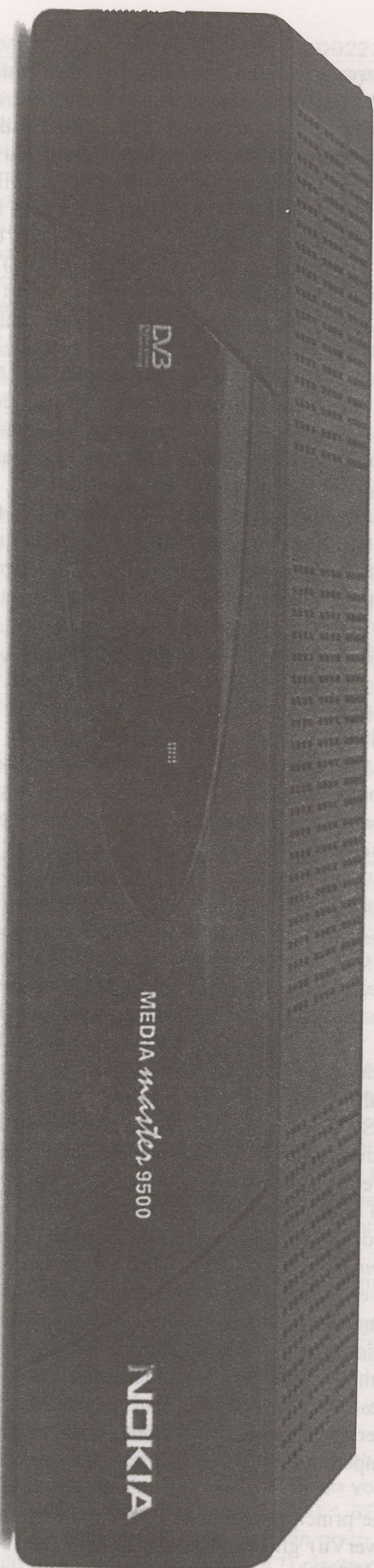

Brings the power of multimedia to your TV.

OPAC Pty. Ltd. **TEL 61-2-9584 1233 • FAX 61-2-9584 1452**

• 99-105 BOUNDARY ROAD, PEAKHURST NSW 2210 AUSTRALIA • Email opac@internet-australia.com

certain what they do with the data stream to cause the Hyundai to panic and ignore the FTA but suffice to say that any programmer that really wanted to deny access to a Hyundai could duplicate this particular data routine and all Hyundai receivers would fall over (which would cause those people who initially selected the Nokia to be extra glad they did so!).

The Hyundai has a good front end (i.e., the tuner has good sensitivity). However, if the signal is weak or if you are tuned to a PowerVu service during a period when they are downloading instructions to PowerVu receivers (i.e., "boot loading"), the HSS-100C will simply lock up. If this happens, turn it off at the mains and then turn it back on.

When the receiver is first turned on, it performs a data check which can take some minutes (wait, wait, wait). You must know all of the digital parameters to get the Hyundai to load (memorise) a bouquet. When you have the bouquet in memory, it gives you a memory "channel number" on screen but no programmer identification. Users make a list which has the receiver memory channel number plus the identity of the programmers on it. When the Hyundai is powered down, it will not always come back to the last channel viewed when powered back up. As often as not when powering up, it will tune to the strongest signal in the memory which corresponds to the satellite and polarisation which you are pointed towards. When you are selecting programme channels inside of a particular bouquet (such as the California PowerVu group), as you scroll channel to channel to the last viewable service (FTA-Bloomberg Financial), the Hyundai seems to lock there. Not so - it is being told to scroll to the next up channel which may not be on the same satellite or polarity. It seems to "lock" in default because you are asking it to find something that is not there.

There is no provision for a CA module or a smart card. And this is the problem with some of the semi-conditional access services. Some service data streams ask the receiver, "*Do you have a CAM?*" and if the answer is no, then the software tells the receiver "*This channel is encrypted.*" Even when it is not - merely not having a CAM is enough to cause the HSS-100C to default to "*This channel is scrambled.*" The HSS-100C also has no signal level indication so you never really know how close you may be to threshold (signal loss) until the signal begins dropping in and out. On the positive side, in addition to the top-rate tuner, it has 14/18 volt switching and does both C and Ku reception. And, as noted, the receiver is fan cooled and it runs at a very tidy, comfortable temperature.

The Nokia 9500 S

As most everyone now knows, the principal problem with the Nokia is the "NTSC (PowerVu) glitch." The 9500S will view all free to air PAL, NTSC (such as Star

TV) and PowerVu (NTSC or PAL) services. It gives you PAL direct to screen (no problem) but tries to convert NTSC to PAL with less than complete success. Every 20 seconds the video freezes on the screen, the screen may go black for a millisecond and then the reception comes back perfect until the next glitch 20 seconds later.

The glitch can be partially corrected by entering (see page 11, bottom) into the infamous red screen menu where you select software commands to convert the NTSC to PAL but running at the unfortunate rate of 60 hertz per second. Now we have a mixed bag - 60 hertz NTSC with a PAL image (which normally is at 50 hertz). If you do this fix on BBC World, you will possibly lose the audio - which you get back by changing programme bouquet channel and then returning to BBC.

The Nokia will find a bouquet for you if you know the approximate frequency but do not know the FEC or symbol rate. There is no other receiver that will do this. Once the bouquet is found, it loads up the programme channels on the menu in front of you assigning a memory channel "number" to each programmer along with an on screen identification of the service. It extracts this ident information from the data stream (as does the D9223).

I am not certain how many bouquets or programme channels it can stack in memory since nobody in the Pacific - to the best of my knowledge - has managed to fill it up as of yet. (It is certainly well beyond 100 - our 9500S is now at 140 programme channels in memory and still adding - editor). Once in memory, if your dish is pointing at the proper satellite and you have the appropriate polarity, selecting the desired programme channel from the memory (with the remote control) brings up the service instantly - no waiting. When the Nokia is powered down and back up, it returns to last channel viewed.

Now - there are several software versions of the 9500 S in the Pacific and Asia regions and not all versions operate exactly as mine does. This is about the "e3" version (as shown on the front panel LCD when the receiver powers up) with the 2.233(4) software (which may appear on a white sticker on the bottom of the case). I understand this (2.233[4]) version is sold in Europe as the Mascom 9200S. The primary difference in the software versions is the ability to memory stack (earlier versions would only stack 4 bouquets maximum) and the red menu operation. The Nokia has a CAM spot and a smart card slot but to the best of my knowledge none of the units shipped to the Pacific have the CAM installed or functional; and for good reason (1).

The Nokia front end is the equal of the Hyundai (very good) and both are significantly more sensitive than the D9223 (in fact, Nokia and Hyundai source their tuners from the same manufacturer). And, 14/18 volt switching is built in and the Nokia will do either C or Ku with equal ease. Of some importance, the Nokia has a signal

MORE Hints and Kinks With the D9223

If you are in Menu 3 (search), DVB mode, and for some reason the signal goes away (is lost), the receiver will resume "search" on its own. If by chance (such as on AsiaSat 2, Chinese SCPC) it locates another service with the same FEC and Msym parameters, it will lock to this new service and stay there. I therefore suggest that if you are not "playing" with this toy mode, you leave it off for general reception. And, if you are clever you *can* store two different bouquets. Go to DVB mode and store the FEC, Msym, frequency for (example) CCTV (which is PowerVu). Now change to the DVB mode, to the installer menu and enter a new frequency, FEC and Msym for a service such as NBC which is not PowerVu. Save these numbers. Now go to view and channel up and you should find the NBC services. By switching from DVB to MPEG, you can change between a PowerVu service and a non-PowerVu service with both in resident memory. Yes - this data stays in memory even when you power down.

level display which is very useful in determining relative "lock-ability" of signals you locate. As soon as you enter the (correct) frequency into the Nokia "Antenna Adjustment" menu, the bottom of screen signal level indicator will change (the red line will move to the right indicating more signal).

And about the red screen menu. What you are doing is asking the receiver to process 60 hertz NTSC as 60 hertz PAL. PAL is by definition 50 hertz and picture blemishes (top of screen flagging, especially on blue; brief freeze framing on occasion) results. If you follow the red menu process, within (say) the California bouquet, you can then surf through the bouquet after one-time entering instructions. You can also surf to NBC and it will process the PAL x 50 hertz as PAL x 60 hertz (again, with flagging). What you cannot do is surf and then watch a PowerVu PAL format bouquet (such as CCTV). It will surf fine and stay acceptable for 3-4

minutes, and then go to a grey screen 'crash.' The way out is to power down and then back up again and start over. The Nokia is uniquely software equipped for serious surfing since it includes hexadecimal options. Hint: When in the red menu, push no buttons other than channel up/down and on/off. Wrong button equals grey screen crash every time!

Finally

The present breed of MPEG IRDs are at best susceptible to software and power line faults. Heat, as I have written here previously, is a significant problem and can only be cured by cooling the IRD (see SF#33, p. 6). A very reasonable investment for any IRD is a Power Surge/Power Spike Protector. And remember - neither Nokia nor Hyundai make any claims for NTSC or PowerVu reception. You cannot hold either firm responsible if for whatever reason the data stream changes and your receiver stops processing.

1/ About the Nokia 9500 S CAM and smart card routine. The software version of the Nokia "e3" described here is identified as "2.233(4)" but this can only be found on a loosely applied white sticker stuck to the bottom of the receiver. The sticker may well have dropped off before you unpack the unit from the factory. The Nokia/Mascom 9200S, which is sold in Europe as a "free to air" receiver, also uses the same 2.233(4) software. In the (Pacific/Asia) e3 version, the CAM **are-you-there?** software is overwritten (bypassed) which is what allows *this version* receiver to access data streams that contain the CAM? question. However, as European Nokia-Xpert Christian Mass reports:

"Since you don't really need to receive pay-TV packages with this receiver, a CAM (module) is not included (by the factory). But a CAM can be plugged in if you want to. The funny thing is that officially you should not be able to add a CAM. The 'sliders' for the CAM (built into the receiver to accept the insertion of a CAM as an after market add-on) have been made slightly shorter, by Nokia at the factory, to prevent you from adding a CAM. You can still do so, with care. Isolate the bottom of the CAM with some insulating tape to prevent a chip resting right below the CAM insert hole from being rubbed by the CAM parts. That is it!" It appears the (Pacific/Asia) e3 version and the 9200S (European) version do not approach the **cam-are-you-there?** data stream bits with the same result. Therefore, it is unlikely the e3 will work with a CAM added since it ignores the CAM? in the first place. Which says we have the better version out here!

Robin's "Short-Form" Nokia NTSC to PAL 60 Hz

FIRST - find a service that is running NTSC (i.e., EWTN). Lock the image, pull out the antenna lead (or switch polarity) so the image will freeze on the screen (after 2 seconds, image may disappear or screen may go blank - this is OK). Now enter the following commands (*):

(1) *TV (display on Nokia LCD changes from EWTN to TV); (2) * Radio; (3) * 99; (4) * Radio; (5) * Menu; (6) *4 ("Encoder menu"); (7) *Push right arrow, then enter following with "OK" after each entry ("Mark" in German language menu versions); (8) * Pair; (9) *71; (10) * B3 (when you enter this command, you should notice the screen move left slightly. B is equal to radio button.) (11) * 6E; (12) * 40; (13) * 61; (14) * 03 (when this command is entered, screen will flicker slightly and then go to full width); (16) * OK; (17) * TV; (15) *Radio; (16) * TV. EWTN should now reappear on front LCD display; plug antenna/LNB line back in or reflip the polarity and you have EWTN in glorious PAL 60 hertz. Note the above command sequences originated with 'Boy Scouts' in Europe but have been modified by

Robin Colquhoun for Pacific use.

"Monopoly is a terrible thing, until you have it"

RUPERT KEITH MURDOCH MAD or MAGNIFICENT?

"Murdoch's enthusiasm for satellite television - which has been the distinguishing feature of News Corporation's development in the 1990s- is heavily influenced by his politics. When, in September 1993, he launched a new range of programmes on his BSkyB service, he declared:

Advances in the technology of telecommunications have proved an unambiguous threat to totalitarian regimes everywhere ... satellite broadcasting makes it possible for information-hungry residents of many closed societies to bypass state-controlled television.

"Murdoch illustrated his arguments by referring to the way in which the horrors of famine in Africa and the war in Bosnia had been brought to our television screens. But within minutes he was also talking of the power of satellites to overcome government regulation and within twenty-four hours caustically referred to the BBC, ITV and Channel 4 as 'government controlled.' The images that bypass the controls of governments which Murdoch dislikes are, of course, chosen by those who own and run Sky. The only choice the viewer has is to switch the television set on or off." (1)

Rupert Murdoch owns or controls Asia's STAR TV, Britain's BSkyB, India's ISkyB. Firms he owns or controls manage the digital version Palapa Indovision, South America's Televisa. News Corp, his basic operating company, owns significant portions of Australia's Foxtel and more recently moved to control DTH provider Australis-Galaxy as well. It also owns 30% of the newly reformed TSAT, an American DBS provider that started life as Primestar. One year ago a New Zealand Murdoch controlled firm (INL) entered negotiations to acquire up to 80% of New Zealand Sky Network. Those negotiations died in February, but are back active again with every likelihood Murdoch will control and operate NZ Sky shortly.

His personal net worth, a measure of his assets, is estimated by knowledgeable business journals to be in excess of US\$3 billion. He is ranked number 10 world-wide in a list that has as undisputed number one-most rich person in the world William Gates of Microsoft (et al) at US\$36.4 billion. Not bad for an Australian boy that entered the world of publishing while attending Geelong Grammar School in 1947.

1/ Quoted from **MURDOCH The Great Escape**, revised and updated edition published by Warner Books (1994).

Murdoch's father, an Australian journalist with then-modest holdings, sent his son to work in the newspaper world as a cadet reporter. While Rupert was attending Oxford, senior Murdoch invested into a minority holding with News Limited, publisher of the *Adelaide News*. In 1953, his father deceased, Murdoch returned to assume the role of his father at age 23. News Limited at the time controlled but did not wholly own the *Adelaide News*, the *Sunday Mail*, *Radio Call* and the *Barrier Miner* in Broken Hill. At that time, it is unlikely News Limited, now controlled by Rupert, had a market valuation in excess of A\$1 million. In 1997, News Limited is the largest family-controlled media business in the world with newspaper and magazine holdings throughout the Pacific, Asia, Europe and North America. In recent years News Limited has paid as much as US\$2.3 billion for a single magazine (*TV Guide* in the USA; 1988).

To date, eight separate books about Murdoch have been published. More are in progress. At 66 years of age, he has attracted more media attention than anyone else on the "Rich People" list; even more than Microsoft's Gates. Each book tries to unravel the complexity of the man, to determine what motivates him, how his rules of life have allowed him to amass such tremendous power, and with that, wealth. Most of the accounts portray Murdoch as a magician with finance and spell out in endless detail how he has repeatedly rescued his various businesses from the brink of disaster by swift financial manipulation. Several knowledgeable books, written with the assistance of former Murdoch employees (of which there are legions), suggest his debts are so huge that not even Rupert himself could accurately complete a financial statement.

His father and the legacy left to him by the senior Murdoch apparently created two unbendable rules that Rupert has followed religiously since 1953:

- 1) Never lose control of your company, but use other people's money to finance your growth; and,
- 2) Let politicians fear your power and call upon them for favours when necessary.

Nothing builds a relationship with politicians better than owning newspapers, radio and television stations, even television networks. Books about Murdoch chronicle hundreds of instances where a Murdoch controlled media outlet has come to the support of an ailing politician, or in reverse, sped up the demise of an out of favour politician. Margaret Thatcher was (and remains) a close friend. When British law stood in the

Murdoch / News Corp Owned /Controlled/Invested Satellite Transponders

AsiaSat 1 (to be AsiaSat 3; 105.5E) / 9 C band transponders; **AsiaSat 2** (1005.E) / 3 C band transponders; **Astra 1A** (19.2E) / 5 Ku transponders; **Astra 1B** (19.2E) / 5 Ku transponders; **ASTRA 1C** (19.2E) / 1 Ku band transponder; **ASTRA 2A** (to launch to 28.2E) / 14 Ku band transponders; **Galaxy 5** (125W) / 1 C band transponder (on behalf of The Family Channel); **Galaxy 7** (91W) / 4 C band transponders (on behalf of FX and Fox Network USA); **GE1** (103W) / 6 C-band transponders (on behalf of various sporting interests); **GE2** (85W) / 24 Ku band transponders (with Primestar/TATS); **Intelsat 703** (57E) / 1 C band transponder; **JC-Sat 4** (temporarily 150E) / 12 Ku band; **Optus B1** (160E) 3 Ku transponders on behalf of Sky NZ (when deal is announced in September); **Optus B3** (156E) / 2 Ku band transponders (on behalf of Australis -Galaxy); **Palapa C2** (113E) / 2 C band transponders (on behalf of Indovision); **PanAmSat PAS-2** (169E) / 1 C band transponder (on behalf of Fox Sport); **PanAmSat 3R** (43W) / 1 C band transponder (on behalf of Fox Sport); **PanAmSat PAS-4** (68.5E) / 7 Ku band transponders; **PanAmSat 6** (to launch, DBS service to South America) / 12 Ku transponders; **SATCOM 1** (137W) / 7 C band transponders (on behalf of Fox Sports, Fox Network); **SATCOM 3** (131W) / 1 C band (on behalf of The Family Channel); **Telstar 4** (89W) / 4 C band (on behalf of Fox Network) USA; **TEMPO 2** (118.8W) - 24 Ku transponders

way of Murdoch acquiring an upper hand in some business relationship, PM Thatcher appears to have rescued him on numerous occasions. In return, his newspapers supported Lady Thatcher and railed against her opponents for as long as she was in power. When Murdoch expanded to the United States, a personal relationship with (then) President Ronald Reagan was instrumental in gaining approval for Murdoch acquisitions. When a regulation that stopped Murdoch from becoming a major power in the US media stood in his way, he quietly and without fuss became a citizen of the US with the full and probably necessary support of politicians.

Control. One account tells the story of a young Murdoch, attending Oxford, vacationing through France in a car provided by his father. A companion for the trip claims he repeatedly asked Murdoch to stop 'here or there' and the requests were ignored. Exasperated, the companion finally exclaimed - "*Why won't you let me make any of the decisions about where we go, stop or eat?*" And the answer: "*This is my car, I am the driver and I will decide where we stop, when and for what purpose.*"

Control. In the newly emerging digital satellite world, it is called encryption. With the appropriate data stream, every digital receiver in the world can be told "*where to stop, when and for what purpose.*" The man who owns the encryption system controls what you will watch or not watch.

News Datacom Limited (recently renamed News Digital Systems - NDS) is a wholly owned News Limited subsidiary. NDS is headquartered in Israel and they specialise on behalf of Murdoch in scrambling algorithms. NDS automatically has as clients all Murdoch owned or controlled satellite delivery services. That includes Galaxy in Australia, Star TV in Asia, ISkyB in India, BSKyB in Europe - in fact virtually every pay TV system in the world (including the DirecTV DTH service in North America) is a user of NDS algorithms. If they are not (presently) owned or controlled by Murdoch, they are his customer through NDS (as is, for example, Sky NZ for their Videocrypt algorithms). Murdoch recently explained his passion for

this seemingly mundane segment of the pay television business:

"We invest in technology so that no one can act as a gatekeeper between us and our customers and we maintain control over our distribution and content."

Translation? "*I own the car, and I will decide when and where we stop, and for what purpose.*" Murdoch, perhaps with great insight, has to date stayed out of the IRD (receiver) business. Of course his relationship to UK supplier Pace is legendary - a co-founder of Pace recently told a British journalist, "*If Murdoch one day decided to stop his orders or stop sending cheques for past deliveries, Pace could disappear in a puff of smoke - overnight.*"

Pace depends upon the various Murdoch digital DTH platforms world-wide to stay in business. Murdoch does not have to build the receivers to control the receiver business - because through NDS he controls the encryption routines which allow the Pace receivers to operate. Why buy the car if you control the petrol supply?

Ten, even five years back, if you wanted to develop a broadcasting service to a new country or region of the world, first you would have to obtain licenses in the target country for broadcast transmitters. First and foremost, that always involved politics. Nations defend access to their airwaves with the same vigour as they defend their borders. In Asia, ultimately a model for the rest of the world, Star TV (Asia) gambled with a brave, new concept. Replace terrestrial TV transmitters with a satellite service, leap above the borders and go directly to the audience without passing the politicians. Star's idea was so good, and successful so rapidly, that Rupert Murdoch simply had to buy out the founders and own it.

He did this at a time when his UK satellite service was just recovering from a near fatal bout of financial losses - to the tune of losing US\$25 million *each week!* There would turn out to be significant operating differences between the UK BSKyB and the Asian Star TV. In England, the market was clearly defined - the British Isles. One language, one set of business and social

values, and a national passion for soccer. Plus, Murdoch had the valuable support and aid of his wholly owned national newspapers and a list of political favours "owed" by those still in power.

Asia was 53+ countries speaking several hundred languages. Some were democratic and elected their leaders, many others were ruled by various forms of military or political clicks. When Rupert Murdoch proclaimed, "*satellite broadcasting makes it possible for information-hungry residents of many closed societies to bypass state-controlled television*," he got a response. Chinese officials declared ownership of a satellite dish "capable of receiving foreign telecasts" illegal. Malaysia declared Star TV "not welcome." Iranian leaders demanded that 250,000 home satellite dish systems be taken down, and turned in to the authorities. Indian politicians tried to pass a law to make viewing of Star TV illegal, failing that created a taxation category guaranteed to keep Murdoch from earning any money in their country.

Murdoch's September 1993 statement got him far more of a reaction than he had anticipated. Retrospectively, his intent was to hype the public stock flotation for BSKyB. In fact, the reaction of politicians in Asia caused quite the opposite market reaction. Star TV admits it has never made money for Murdoch; in a typical year since 1994, the annual News Limited financial statement draws a footnote that typically says something like this:

Star TV reaches 130 million people in 53 countries. Its losses are in line with expectations for a start-up business and it has progressed well in the past 12 months.

Since Murdoch assumed ownership control of Star TV (Asia) in 1993, there have been several game plans advanced to make Star profitable. Late in 1994, Star executives announced a plan that is still unfolding. Although Star had been created (by Hong Kong based Hutchvision) as an 'Asia-wide' service platform, Murdoch realised after his infamous "*satellite television makes it possible ... to bypass state-controlled television*" speech that in fact this was not the model to profitability. Hutchvision, still new and hardly out of the glamorous start-up phase when acquired by Murdoch, believed that if you filled the satellite airwaves with imported American, British and other English language programming, you could be a success. Politicians in countries such as China, Malaysia and India saw 'Baywatch' and 'Beverly Hills 90210' as electronic 'imperialism' and were certain in advance they did not want their countrymen walking the streets imitating rap music picked up from MTV.

In October of 1994, a year after proclaiming Star TV would be 'All Asian,' a new plan was announced. Star TV would break up into modules, each one self-contained and language and target area specific. The

mostly English language version might still exist, but it would become less important as Star developed programming alliances with programmers inside of each major target area. India, Indonesia, Japan were three obvious choices for their own brand of Star TV programming. Indeed, as you read these words ISkyB is testing using 7 Ku-band transponders on PAS-4 into India, Indovision is on the streets selling 20+ channels of digital TV from Jakarta (delivered via Palapa C2) and JSkyB is scheduled for a 1998 launch with 100+ digital channels.

China remains difficult. Yes, Star TV has been able to gain approval for a very limited amount of programming delivery (primarily their 'Phoenix Channel') to hotel SMATV systems in China proper. No, there is no "digital bouquet" such as ISkyB, Indovision or JSkyB planned. Chinese officials are still smarting from Murdoch's 1993 speech and an incident that followed, involving transmission by Star of a BBC report that a high Chinese official had engaged in questionable sexual activities. As recently as this June, while addressing a trade conference of the working press in Tokyo, Murdoch was offering an olive branch to the Chinese listening. He said:

"We recognise that China is a distinctive market with distinctive social and moral values that western companies, like News Corporation, must learn to abide by. Certainly, as a company, News Corporation, given the opportunity, would like to work alongside the Chinese in developing advanced DBS (direct broadcast satellite) technologies enabling them to deliver not just multi-channel television programming but government information, training, education and medical services throughout China."

Murdoch, like most of the western economic world, envisions in China the world's most rapidly developing consumer marketplace. China in 1997 will produce 15% of the world's television receivers and VCRs - virtually all for internal consumption. To supplement that production, it will import another 5 million TV receivers. The Chinese announce "plans" in very general terms and then surprise the balance of the world with the detail. An example: 12 MPEG-2 digital TV regional programming channels, dropped onto AsiaSat 2 this past January, with no notice. Murdoch realises that China alone could pay off the losses for Star TV to date and, unlike India or Indonesia or Japan, there is at least a chance that whomever ultimately does win the "Chinese DTH prize" will in fact end up with something approaching an exclusive there.

Programming Control

Classic Murdoch quotations might one day fill a book. Here's one:

"Monopoly is a terrible thing, until you have it."

Murdoch and his top managers believe that sport drives pay TV, followed distantly by movies and more distantly by news. His first serious venture into news was the BSKyB "Sky News (London)" channel, seen on

AsiaSat 2 within several bouquets. More recently, Fox News has been launched in the USA, primarily intended at first for redistribution to America's cable TV homes. In the news area Murdoch locks horns with foe Ted Turner. Turner and Murdoch pretend to hate each other; recently Turner publicly challenged Murdoch to "*put on the gloves, climb into a ring and duke it out*" (with Turner). Seven years Turner's senior, Murdoch ignored the jab. The media world saw it as the ultimate "pay to view" boxing event with a purse in the hundreds of millions of dollars.

Movies are a more difficult issue. For all of his power and money, Murdoch is a light weight in the world of Hollywood. Early in 1985, News America purchased 50% of Fox Films (a Hollywood production company) and by year's end the balance for US\$575 million. There were two reasons: First, his TV networks were going to need films and the products best created in a movie studio. Second, it was an entree into the closely knit world of Hollywood show business and he needed the clout of being a "studio owner" to do deals with other studios. However, Fox Films has been mostly a financial disaster following a lucky streak in 1991 with *Home Alone* and *Sleeping with the Enemy*.

It has been in sport where Murdoch has shown unusual skills. In England, BSkyB paid big money for Premier League Soccer rights. BSkyB subscriptions shot skyward when these matches began screening exclusively on Sky Sport. In New Zealand, he purchased rights to rugby which he then resold in part to Sky Network (NZ). Throughout Asia he has been teaming with ESPN or going it alone to tie up sporting rights well into the next millennium. In America, his Fox TV Network outbid the older, more established, networks for major audience draws such as NFL football, NHL hockey, NBA basketball. Then, in June, he did the sport deal of the century: Joining forces with the world's largest cable TV operator (TCI), for US\$850 million they bought the assets of 7 (US) cable TV sporting networks, Madison Square Garden (the New York City home of big apple sports), the New York Knicks (NBA basketball) and New York Rangers (NHL hockey) plus television coverage rights to 20 Major League Baseball teams, 17 National Basketball Association teams, 12 National Hockey League teams and 20 college level conferences. How much sport is that? Enough to completely fill "more than 12 transponders" with sport, 24 hours a day, 365 days a year. It is not beyond reason to anticipate a series of satellites which carry nothing but sport channels in the decade ahead.

And they are not done yet. Fox Sports will be the home of multiple-multiple channels of sport, linked globally, operating to bring virtually any sport event of interest to any spot on the globe. For a price. The schedule date for "launch" of all of this is the middle of 1998.

Alas - There are wrinkles to iron out

The keys to making all of this work are *financing* and *security*. Billions of dollars are invested in advance sport contracts, movie deals, and hardware orders. Satellite transponders (see table on page 13) are an almost throwaway commodity. With compression techniques nearing a technology plateau, a 36 MHz transponder looks likely to be capable of handling up to 10 full action (sport) channels simultaneously.

Murdoch's people plan 100 to 200 programme channel bouquets wherever the markets are large enough to support such extravagant offerings. Japan, India, Europe and North America will all have 100+ channels to work with. In the likelihood that Australia's Galaxy and New Zealand's Sky end up being rolled into a single service provider serving both countries, under Murdoch management and using not the present Galaxy Irdeto conditional access system but rather a newer News Digital Systems CA, major readjustments are ahead.

The success of the News Digital Systems, certainly the world leader in providing conditional access encryption technology, is a worry to many observers. No, it is not that Murdoch controls everyone's car telling it *where, when and why to stop* that worries these people. Rather, it is the CSA (Common Scrambling Algorithm) approach that all conditional access systems from NDS share. Here's the concern.

The widespread adoption of the MPEG-2 DVB compliant digital standard only makes the piracy-driven hacker's job easier. A piracy-driven individual or firm, once they have mastered the DVB algorithm (which is available in public places for study), then goes to work on the Common Scrambling Algorithm which forms the base level encryption. Each individual programmer, with the assistance of a firm such as NDS, adds a final layer of encryption on top of the first two as their own conditional access architecture.

The situation is very similar to having a combination lock with three sets of "numbers" to be found. The DVB algorithm is available to the public (the first number) while the CSA is supposed to be available only to a broadcaster who has signed a confidentiality agreement. Unfortunately, the "C" in CSA stands for *common* which means that it only takes one leak in the security world-wide for the second "number" to become known to hackers. That leaves a dedicated hacker searching for the third and last "number" to open the safe.

NDS's largest digital DTH customer, DirecTV in North America, was dismayed to identify "hack smart cards" in the US and Canadian marketplace one year ago. Pirates had found all three "numbers" and now the safe door was open. Arrests and court cases followed. More recently, late in July in fact, similar pirate cards surfaced in Europe which allow access to digital bouquets there. Murdoch's entire empire is built on the security of smart cards and if that fails - it's all over.

Comes



SO ...
**YOU WANT TO
INSTALL SATELLITE?**

**HAVE YOU
JOINED THE
BAYSAT TEAM?**

UNCLE BAYSAT would like to remind you that satellite TV does not begin ... and end ... with the new SKY Network service.

There are many, many services on satellite which appeal to tens of thousands of viewers in the South Pacific. We believe these viewers would be quick off the mark to purchase a system that is designed for their particular interests and life styles.

We are forging ahead to create system packages that are easy to sell, quick to install, low in "profile," high in performance and most importantly - **profitable** to you, the dealer.

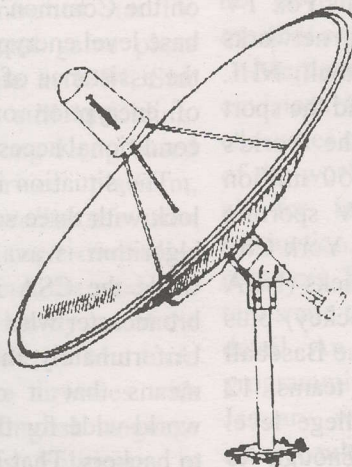

Paraclipse 1.5m Hydro

Our Paraclipse 1.5m **Hydro** for example produces P5 reception from CFI Paris in a complete dealer package under \$800 (+gst)! And we now have cheaper packages of PowerVu (CMT, EWTN) and MPEG-2 DVB coupled with innovative marketing assistance that makes you the local satellite expert.

And remember - Uncle Baysat doesn't send staff into "your patch" to compete with you!

You are just a toll free call away from joining the team that puts profit into satellite TV!

YES!

We **STILL** accept VISA, Mastercard with NO surcharge!

PO Box 3311 • Napier, New Zealand • tel toll free 0800-BAYSAT
International 64-6-843-5296 • Fax 64-6-843-6429 (0800-229-728)
Physical location • 19B Carnegie Road, Onekawa, Napier
<http://www.baysat.co.nz/baysat>
e-mail john@baysat.co.nz

**THE NEXT BEST
THING TO BEING
HARD WIRED
TO THE BIRD...**

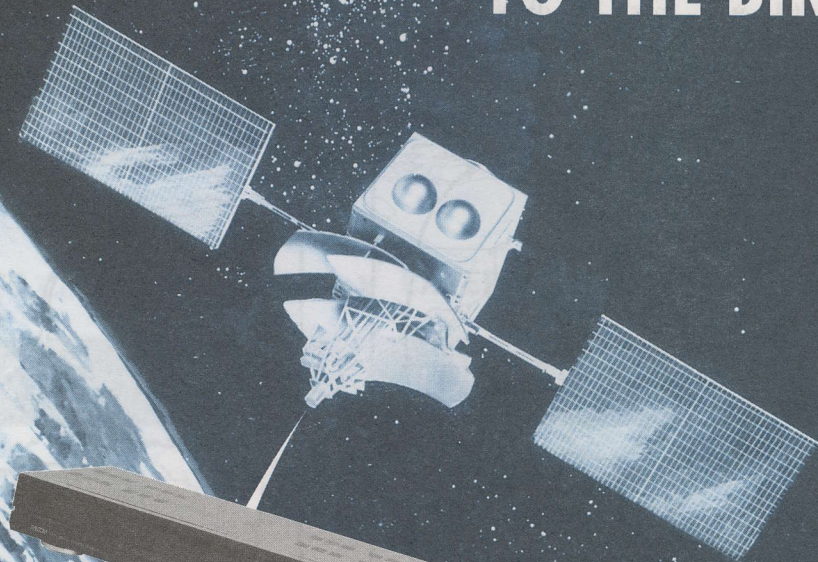

**... The Palcom SL-7900RP
first choice of satellite
experts, performance
conscious installers and
quality driven consumers
across the Pacific and Asia.**

SL-7900RP: 500 channel memory Hi-Fi Stereo satellite receiver with full motorised actuator dish control built-in. Two IF inputs (950-2050 MHz); Standard 27/18 MHz IF bandwidths, plus 32 step threshold extension for signals as weak as 3dB C/N; Fully tuneable audio sub-carrier range (5.5 - 9.5 MHz) independent on L and R channels; Selectable wide (280kHz) and narrow (150kHz) audio bandwidth with J17, 50uS or Hi-Fi 1600 de-emphasis; Full polarizer control; TV modulator (E21-E69) + 3 SCART 21 pin outputs, separate L and R RCA audio outputs. Every function (including antenna, feed settings) logged into memory for instant recall - totally automatic channel search with companion handheld IR remote. Consistently rated by leading publications "Most versatile, low threshold, ultimate consumer receiver" world-wide. Truly, the next best thing to being hard wired to the satellite.

SL-7900RP from Bay Satellite TV Ltd, P.O. Box 3311, Napier, NZ. Tel 64-6-843-5296 (Fax 64-6-843-6429)

with software by....

PALCOM

State of the Art Simplicity

HERE IT COMES - READY OR NOT!

701 to 180E - 511 R.I.P

Intelsat 511 at 180E was launched in 1985. It is tired, old, inclined and troublesome. I701, launched in 1993, will replace it at 180E early in September. There are major changes (in transponder assignments and signal levels) ahead. 701 will mix 33 dBw zone and hemispheric beams with 26 dBw global and 36 dBw

spot beams to create an entirely new array of coverage zones and services for the Pacific. Polarisation will be RHC (right hand circular) or LHC and we'll know more after a month or two of operation. For a unique experience, watch for the "change over" as services move from 511 to 701 and often new transponders.

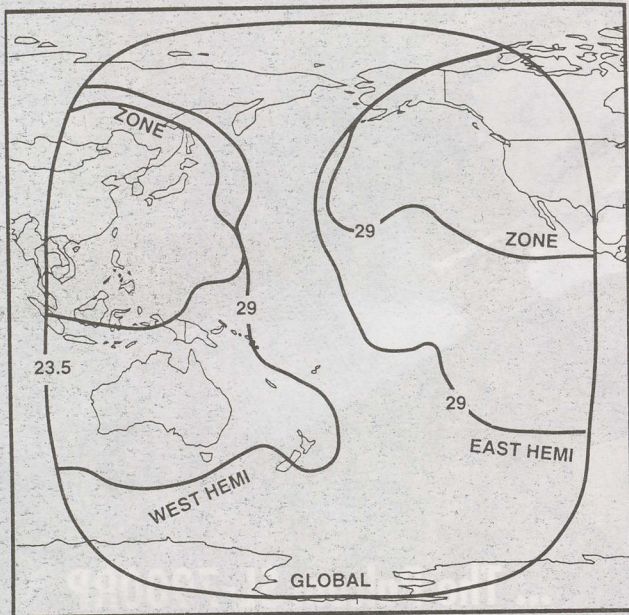

1511 beams and coverage from 180E

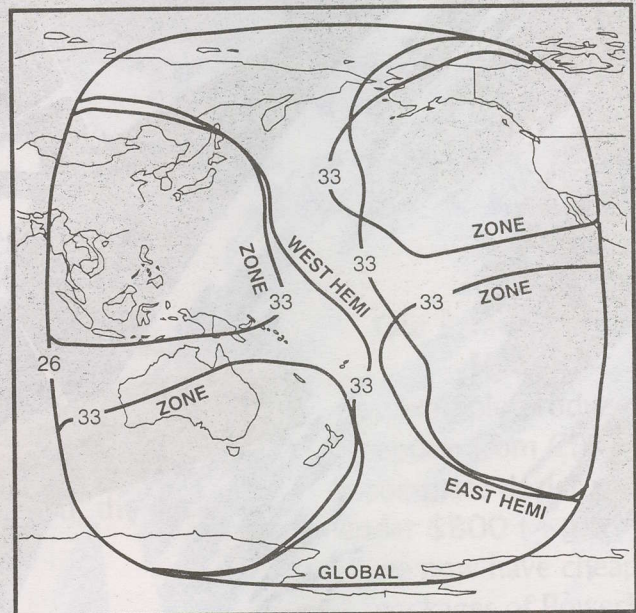

1701 beams and coverage from 180E

TR Number	Bandwidth for 701	A Polarity beam	B Polarity beam	C-band bandwidth	C-band centre	L-band (IF) centre	511 User is /L-band	1511 Maximum	1701 Maximum
1-2	77 MHz	Hemi	Zone	3704-3781	3,742.5	1,407.5	1432 Keystone	29 dBw	33 dBw
3-4	72 MHz	Hemi	Zone	3789-3861	3,825	1,325	1385 10 Aust.	29 dBw	33 dBw
5	34 MHz	Hemi	Zone	3869-3903	3,886	1,264	1274 7 Aust.	29 dBw	33 dBw
6	34 MHz	Hemi	Zone	3907-3941	3,924	1,226	1226 Japan feed	29 dBw	33 dBw
7-8	72 MHz	Hemi	Zone, Global	3959-4031	3,995	1,155	1130 Asian feed	29 dBw	33/26 dBw
9	36 MHz		Global, spot	4037-4073	4,055	1,095	1105 RFO	29 dBw	26/36 dBw
10	36 MHz		Global, spot	4077-4113	4,095	1,055	1054 SCPC LHC	23.5 dBw	26/36 dBw
11	36 MHz		Global, spot	4117-4153	4,135	1,015	1025 9 Aust.	23.5 dBw	26/36 dBw
12	41 MHz		Global, spot	4157-4198	4,177.5	972.5	964-988 TVNZ	23.5 dBw	26/36 dBw

\$49 SATELLITE RECEIVER

COMMERCIAL FLOP / EXPERIMENTER SPECIAL !!

FOR \$49 YOU GET A SINGLE INPUT
12 CHANNEL K BAND RECEIVER WITH-

- ✓ **SYNTHESISED** IF Tuning
- ✓ **FIXED AUDIO** at 6.5 MHz ****
- ✓ **LED DIGITAL** Channel # Display
- ✓ **REMOTE** Control
- ✓ **MAGNETIC** Polariser Driver
- ✓ **14/18V** LNB Switching
- ✓ **RF** Output (VHF)
- ✓ **EXTERNAL** 17V DC 900 ma power supply

THE PARTS ALONE ARE WORTH OVER \$49 !!

These receivers are surplus stock, bulk purchase, pulled out of a commercial network operating on OPTUS B1 a few years ago. They are ideal for monitoring video on any K band analogue transponder. A simple one chip PLL audio demodulator can be built to restore the full audio tuning range. It may also be possible to simply modify them for C-band reception (**). Every unit checked and pre-tuned to transponder 7 on OPTUS B1.

Cat # R999 EXPERIMENTERS RECEIVER
(A)\$49 AS IS (+ freight/shipping).

THESE UNITS are 2nd hand, and have been pre-tested before despatch.

**** A SIMPLE audio demodulator can easily be added to give full range audio tuning; we supply an experimental circuit.

** PHOTOCOPY of circuit and user instructions supplied with each unit.

AV-COMM PTY. LTD.

Direct Importer ACN 002 174 478
PO Box 225, Balgowlah 2093

TEL: 61 2 9949 7417 9948 2667

FAX: 61 2 9949 7095

VISIT OUR WEB SITE AT

<http://www.avcomm.com.au>

✓ YES GARRY, Please reserve the \$49 satellite receiver for ...

NAME _____

Address _____

P'code _____

Phone _____

a technical and marketing
advisory

memo

to the membership from your
industry trade association

SPACE Pacific

Satellite
Programme
Access
Committee



A trade association for users, designers,
installers, sellers of private satellite-direct
systems in the Pacific Ocean & Asia Regions

Selling 'Safe' TV Sex

Visitors to the Pacific during early August have included Stuart Duncan and Fred Pantalone. Duncan is President, Pantalone is Vice President of Operations for the Exxtasy Channel. You will recall SF's full report on the status of adult film channel Exxtasy as a "hitch hiker" within the Intelsat 1177E Space Systems (Mandarin and Asian language) digital bouquet in the July 15th issue (see page 29, here, for an update).

The Exxtasy officials met in Australia and New Zealand with potential users and agents for their services. What they heard was this:

1) The best way to work within the rules that govern television distribution of adult film materials is to operate twin channels; one that is "R" rated and one that is "harder" in content. The R rated channel would follow on-screen guidelines quite universal within the regulatory wording of Australia and New Zealand. All publicity and promo through print and other media would be solely for the 'R' channel.

2) The "harder" channel would only be promoted *within* the R channel programming. The R channel programming would be "hard encrypted" which means that at the very least a smart card conditional access system. In this way the content of the R and more importantly the promotions for the "harder" (as in triple X) service would only be seen by R service subscribers.

In this way the general public would be treated to a visibility of R but not X; the presence of X (which would be an optional extra service available *only* to R subscribers) would be unknown except to the trade and those subscribers who started off with R and then "discovered" that X was also available for an additional fee.

3) The point of origin would be outside of Australia, New Zealand and the Pacific. The satellite delivery would (continue

to) be Intelsat and subscribers would make contact with the service through offshore telephone numbers.

4) To protect dealers of IRDs from being hauled into court, no dealer would have printed literature or promotional material for the hard channel and he would only be promoting the R product. A subscriber would initiate the "X" channel on their own once they "learned about it" through their R channel subscription. (This is the "consenting adult" requirement found in most obscenity laws.)

CEO Duncan agrees his ("X") service *could* be found to be "obscene" but is quick to explain it is not violent, does not use animals nor children. *Obscenity* is often a matter of local/national law interpretation and the R channel would be created to avoid even the hint of obscenity. "*In this way people are buying non-obscene, adult erotica from a local dealer*" (the one who sells them the IRD and satellite dish system - but does NOT take their order directly, even for the R channel).

What is the difference between "R" and "X?" R has mostly implied activity and human body parts; a camera that pans down a human torso towards private parts "slides off the body to the bed" or "goes out of focus" when approaching those parts. In an X film, the camera gets as close to the private parts as is humanly possible and objects 6 inches long become as large as the picture tube face. "R" is *implied*, "X" is *actual*.

Exxtasy may not even be first to become available via satellite in the Pacific. As explained on page 29, their actual commercial start date will be determined by the availability of suitable conditional access IRDs. Also headed our way on Optus B3, DTH, is a service from North America called *Spice International* ("R" rated). This service will be a part of a larger service scheduled to be carried on Intelsat 802 (174E) into the Pacific by a North American programme packager that will also be bringing out 5 "basic" channels intended for cable and SMATV distribution from the I-802 C-band feed. ***

MEMBERSHIP IN SPACE

Membership in SPACE Pacific is open to any individual or firm involved in the "satellite-direct" world in the Pacific and Asia regions. There are four levels of membership covering "Individuals," the "Installer/Dealer," the "Cable/SMATV Operator," and the "Importer/Distributor/Programmer."

All levels receive periodic programme and equipment access updates from SPACE, significant discounts on goods and services from many member firms, and major discounts while attending the annual SPRCS (industry trade show) each January in Auckland. Members also participate in policy creation forums, have correspondence training courses available. To find out more, contact (fax) 64-9-406-1083 or use information request card, page 34, this issue of SatFACTS. Page space within SatFACTS is donated each month to the trade association without cost by the publisher.

Year #30* Filters For Cable TV • TVRO • Interference

New 100 Page Filter Catalog

Has a filter for every application

- CABLE TV SYSTEMS
- SATELLITE RECEPTION
- OFF AIR INTERFERENCE

CONTENTS

CATV:

HISTORY

BANDPASS FILTERS

CHANNEL DELETION FILTERS:

Single channel deletion filters

Multiple channel deletion filters

LOWPASS FILTERS

HIGHPASS FILTERS

CHANNEL REPROCESSING NETWORKS

BANDSPLITTERS (hi/lo diplexers)

PAY TV TRAPS & FILTERS:

History of CATV trapping

INTERFERENCE SUPPRESSION

NETWORK PASSIVES

DROP LINE DEVICES

WEATHERIZED HOUSINGS

GET
IT
TODAY!

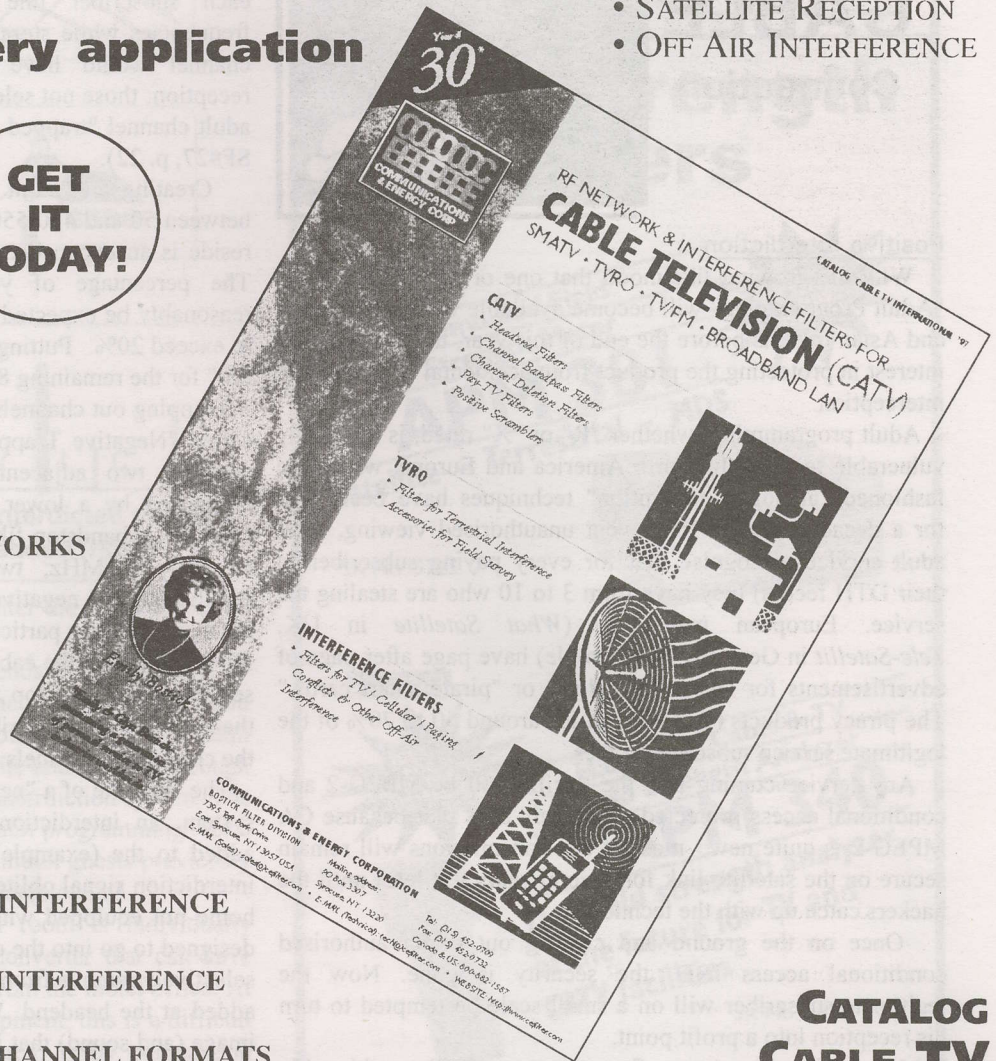

TVRO: FILTERS TO SUPPRESS INTERFERENCE

BOOKS: CATV, TVRO, MMDS, INTERFERENCE

APPENDIX A: INTERNATIONAL CHANNEL FORMATS

APPENDIX B: INTERNATIONAL CHANNEL FREQUENCIES

APPENDIX C: ORIGIN OF CATV, TVRO, PAY-TV

CATALOG CABLE TV INTERNATIONAL/97

More than a catalog of products-
It's also a tutorial on CATV history and practices.



Emily Bostick
President

Emily Bostick

***Emily & Glyn Bostick -
Continuing a generation
of personal service to
TV industries -WORLDWIDE!**



7395 Taft Park Drive
East Syracuse, NY 13057
Mailing address:
PO Box 3307
Syracuse, NY 13220
Tel: (315) 452-0709
Fax: (315) 452-0732
Canada & US: 800-882-1587

DISTRIBUTOR INQUIRIES INVITED

Telephone: 315-452-0709

Fax: 315-452-0732 USA

Literature: Ileen Feinberg

Technical: Dave Dann, Tracy Warren, Steve Shafer, Glyn Bostick

The CABLE Connection

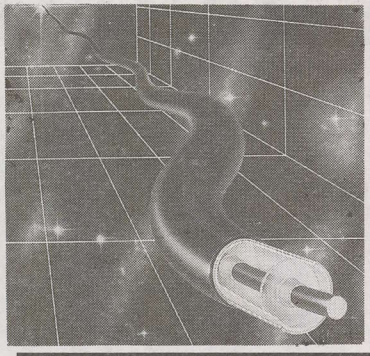

Positive Interdiction

With the growing likelihood that one or more channels of "Adult Programming" will become available within the Pacific and Asian regions before the end of this year, there is renewed interest in protecting the product from accidental or purposeful interception.

Adult programming, whether "R" or "X" rated, is especially vulnerable to theft. In North America and Europe, where old fashioned "analogue encryption" techniques have been used for a decade or more to prevent unauthorised viewing, most adult services recognise that for every paying subscriber to their DTH feed(s) they have from 3 to 10 who are stealing the service. European magazines (*What Satellite* in UK, *Tele-Satellit* in Germany for example) have page after page of advertisements for "pirate decoders" or "pirate smart cards." The piracy products typically sell for around 50 to 70% of the legitimate service subscription fees.

Any service coming into the Pacific will be MPEG-2 and conditional access protected. That only says that because CA MPEG-2 is quite new, most of the transmissions will remain secure on the satellite link for several years - at least until the hackers catch up with the technology.

Once on the ground and coming out of an authorised conditional access IRD, the security is gone. Now the legitimate subscriber will on a small scale be tempted to turn his reception into a profit point.

Most adult programmers first attempt to affiliate with cable firms through a written contract. If an adult service commands \$25 in local currency per month from a cable subscriber, it probably is being purchased for as little as \$4 per subscriber per month to around \$10 per month. So on the surface, a cable system selling 100 homes this service for \$25 per home per month stands to profit by as much as \$2,100 per month for this one channel. There are few (if any) other channels which the cable operator can sell for so much and buy for so (relatively) little. This helps the cable operator overlook the nature of the product he is handling.

However, the once secure satellite transmission, now on the ground and in basic PAL (or NTSC) in the cable headend, must now be resecured against theft while it travels through the cable system. Once again, it must endure encryption. One form of security is to create programming "tiers" using traps at each subscriber line connection; the traps pass some frequencies while stopping others. A home electing the adult channel would have a subscriber trap permitting such reception; those not selecting the adult channel would have the adult channel "trapped out" at the tap-off box street side (see SF#27, p. 22).

Creating an "adult tier" (i.e., a portion of the spectrum between 50 and 450/550/750 MHz) where only adult channels reside is an expensive method of securing the adult services. The percentage of your total subscriber base that can reasonably be expected to take adult services is small; seldom to exceed 20%. Putting in special traps to eliminate the "adult tier" for the remaining 80% of subscribers is cost prohibitive.

Trapping out channels not purchased by a particular home is called "Negative Trapping." Such a trap can stop one single channel, two adjacent channels, or a band of channels delineated by a lower and upper stop-band frequency. For example, a bandstop filter might eliminate all signals between 61 and 78 MHz; two low or band "I" channels. The disadvantage to negative trapping is that every home that does not subscribe to a particular service requires a bandstop trap. If 50% or more of the cable subscribers elect to take a particular service, then bandstop traps make economic sense since less than 50% of the subscriber homes will require the trap to keep the channel or channels out of their drop cable lines.

The opposite of a "negative" trap is a "positive trap." In this system, an interdiction (interfering) carrier (or carriers) is added to the (example) adult channel at the headend. This interdiction signal obliterates reception of that channel for any home not equipped with a positive trap. The positive trap is designed to go into the drop line to the subscriber home and to selectively remove from the drop line the interdiction carrier(s) added at the headend. What goes into the positive trap is an image (and sound) that is totally obliterated by the interdiction signal(s). What comes out of the positive trap, and to the customer's TV set, is clean picture (and sound) with the interdiction removed. The positive traps go only on the subscriber drop lines when that home has subscribed to the service in question.

Positive trapping with interdiction lends itself to adult channel marketing. Every home on the cable system has access to the channel, and subscribers can order the service and have it cleared of the interdiction carriers by simply going to the customer home, opening the pedestal (tap-off) container and adding the positive trap to the drop line going into the house.

small, medium and LARGE C and Ku antennas in stock!

Transmit and receive antennas from 1.2m to 13m (Intelsat Standard B). Linear and circular feeds (AsiaSat, Palapa, JcSat, Rimsat, PanAmSat, Intelsat and more) for transmit and receive-only applications. Receive and transmit electronics including inclined orbit tracking equipment with motor drives for elevation and azimuth to 50 tons. Complete system design, fabrication, installation + proof of performance.

P
A
C
I
F
I
C

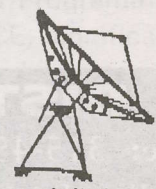

Limited

A
N
T
E
N
N
A
S

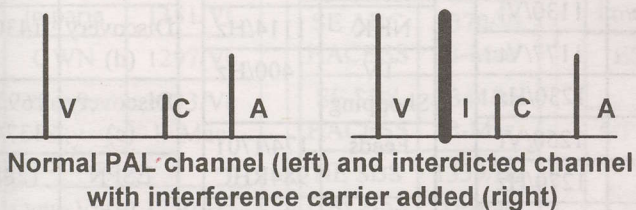
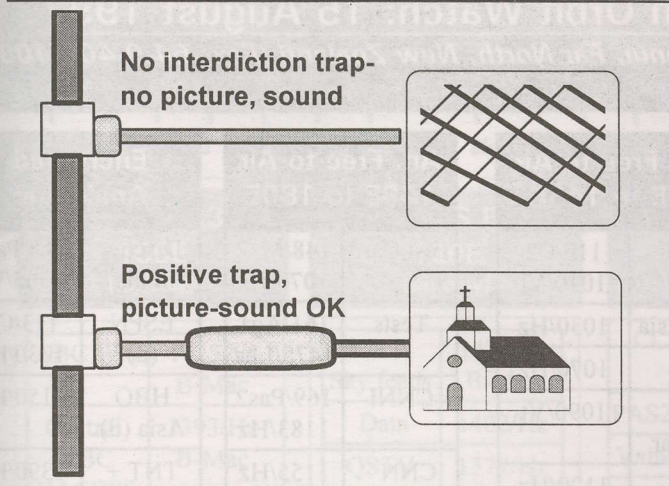

The cable operator does not need to enter the home unless he wishes to do so.

Positive trap, interdiction, also lends itself to SMATV installations in a hotel or motel. Assume a system where adult movies are on offer to rooms as an optional extra. The adult movies come into the facility via satellite and are sent through to the rooms through a modulator and interdiction system. The motel operator offers "An evening of adult programming" for a flat fee; \$15 would seem a bargain for motel guests previously offered individual adult movies for upwards of \$12.

In complex systems each motel room is individually addressable through a costly set-top converter that can have individual channels turned on and off from the motel office. At upwards of \$600 per room for the equipment, this is a difficult sale. A positive trap, interdiction system is by comparison inexpensive. Add the interdiction unit (typically around A/NZ\$1,500) and then supply the motel operator with a box of positive traps (typically A/NZ\$30 each). Now when a room wishes "Adult programming" the room is given a positive trap that "snaps into place" in a small box attached to the back of the TV set. Once in place, the adult channel magically is clean of interference. The motel guest is responsible for the trap and if not returned is charged a hefty non-return fee when they check out.

Thus positive interdiction supplies a method for small motels and other similar facilities to offer "adult movies" for a fraction of the capital costs of fully addressable systems. And cable systems of all sizes, not yet into addressable converters, will also find this an economical way of controlling one or more channels to individual homes.

Note: The complete world of positive and negative trapping, including interdiction systems, is explained in detail in the free 100 page *Communications & Energy Corporation 1997-1998 Filter and Interference Handbook*. If your business is studying the possibility of offering SMATV or other controlled access pay TV viewing to clients in the future, we encourage you to contact CEC for a free airmail copy of this excellent reference work. (CEC, PO Box 3307, Syracuse, NY USA 13220; fax ++-315-452-0732).

KONIG ELECTRONIC

Field Strength Meters

KONIG ELECTRONIC

Combined Field
Strength Meter

APM 381

Satellite - Terrestrial - MDS

IDEAL FOR
SAT TV - TV
& MDS
INSTALLERS

SK No. 5785

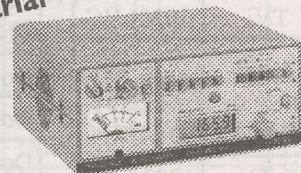

KONIG ELECTRONIC

IDEAL FOR
CABLE TV & TV
INSTALLERS

Hand Held Cable & TV
Field Strength Analyzer

APM 340

The Field strength analyzer
of the future for TV and
CATV facilities

SK No. 5777



KONIG ELECTRONIC

Field Strength Meter
APM 746 SAT

Professional multistandard
field strength meter
for worldwide
application

IDEAL FOR ALL
PROFESSIONAL
INSTALLATIONS

SK No. 5788

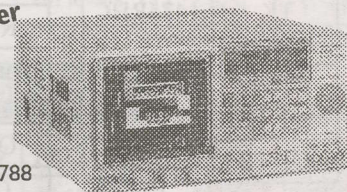

For more information on our full range
of Konig Service Instruments &
Specifications please contact:-
Skandia (61 3) 9819 2466

Distributed in
Australia & NZ by

Skandia

Skandia Electronics Pty Ltd

Victoria: 183 Burwood Road Hawthorn, Victoria 3122 Australia
Telephone: (61 3) 9819 2466 Fax: (61 3) 9819 4281
NSW: Level 1, 39 Terry Street, Rozelle, NSW 2039 Australia
Telephone: (61 2) 9555 2955 Fax: (61 2) 9555 2455

SatFACTS Pacific/Asian Region Orbit Watch: 15 August 1997

Copyright 1997: SatFACTS, PO Box 330, Mangonui, Far North, New Zealand (Fax: 64-9-406-1083)

Analogue Free-to-Air 57E to 80E

Sun Music	57E/703 1400RHC
Sun Mov.	1342RHC
Gemini	1257RHC
Sun TV	1220RHC
AsiaNet	1170RHC
WorldNet	1100RHC
NEPC	1090/LHC
TVi	1020LHC
Muslim	975LHC
ESPN Feeds	64E/801 1134RHC
E-TV	1093/LHC
VIJAY TV	965RHC
Home TV	68.8/Pas4 Vt1310
ABN	Hz/1365
Sony TV (Hindi)	Hz/1240
Doordar & Iran TV	Vt/1116
CNNI	Hz/1065
TNT/Cart.	Hz/1040
ATN	Vt/995
BBC World	Vt/1350
MTV Asia	Hz/965
BBC Interna.	78.5/Th3 Vt/1275
Army TV NNV 5	Vt/1395
TK Rossija	1475RHC
VTV4/Mos. TB6	1275RHC
ACT/TB3	1127/RHC

Anal. Free-to-Air 80E to 113E

Russia 3	80/Exprs 1080RHC
Dub'l II	90/S6 1475RHC
Orbita II	1275RHC
Dub'l I	1234RHC
Orbita I	1208RHC
VTV	91.5/Me1 Hz/1440
Doordar.1 National	93.5/In2b 1030/Vt
Doordar.1	1160/Hz
Doordar.9	1080/Hz
Doordar.7 Telugu	1070/Vt
Doordar.9 Kanada	1180/Vt
Doordar.1	1268/Vt
Doordar.	1310/Vt
Doordar.3	1348/Vt
Doordar 4	1388/Vt
Orbita II	96.5/S14 1475RHC
Madagascar	1325RHC
ERTU Egypt	100.4/As2 1508/Hz
TV Shopping	1490/Vt
Mongolia, Iran/plus	1470/Hz
WorldNet	1265/Hz
CCTV4	1190/Hz
RTPi	1170/Vt
Dub'l II	103/S21 1475RHC
ORT	1275RHC
CFI	113/C2 990/Hz

Anal. Free-to-Air 113E to 145E

Brunei	113/C2 1010/Vt
MTV Asia	1030/Hz
TPI	1070/Hz
TV Indosiar	1090/Vt
ABN	1120/Hz
ANteve	1130/Vt
CNNI	1177/Vt
GMA	1230/Hz
TV3	1250/Vt
ATVI	1270/Hz
TVRI	1310/Hz
RTM	1330/Vt
RCTI	1408/Vt
CNBC	1530/Hz
Test Card	128/Jc3 1065/Vt
CETV SD	134/Ap1A 1356Hz
CETV4	1314/Hz
CETV2	1272/Hz
CNNI	1174/Vt
CETV	990/Hz
Orbita-I	140/S7 1475RHC
NTV	1425RHC
RAJ-TV	142.4/R41 1425LHC
ViJay TV	1325LHC
EM TV	1272LHC
Dub'l-I	145/S16 1275RHC

For MPEG-2 format digital, see pages

An. Free-to-Air 148E to 180E

Test Card	148/Me2 1070/Hz
Tests	161/Ag1 1475/Lhc
CNNI	169/Pas2 1183/Hz
CNN Feeds	1155/Hz
NHK	1114/Hz
TV Shopping	1400/Hz
Feeds	174/I701 984RHC
Feeds	973RHC
Feeds	177/I702 984RHC
Feeds	963RHC
Feeds	180/I511 1430RH
Feeds	1175RH
RFO	1105RH
Feeds	1020LH
Feeds	984RHC

Encrypted Analogue

Discov. India	68.8/Pas4 1365/Vt
ESPN (d)	113/C2 1030/Hz
HBO Asia (d)	1150/Hz
TNT + (d)	1390/Hz
Discovery (d)	1430/Hz
Discovery (c)	169/Pas2 1374/Hz
ESPN (a)	1288/Vt
TNT + (a)	1218/Vt

NON MPEG-2 DIGITAL SERVICES

People's Net (GI 1.5)	113/C2 1110/ Hz
RPN-9 (GI 1.5)	142/G2 1375Lhc
Fox/Prime (SA 1.5)	169/ Pas2/ 1161/Vt
Filipino Channel (GI 1.5)	1060/Hz

AUGUST ALERT

New Chinese domestic bird DFH-3 should now be at 125E, C-band, and reportable. Agila 2, if successful in launch, will go to 144E replacing B2P now in inclined orbit. Insat 2D launched in June, could go to 74E or 97.5E, subject to last minute Indian decision. I701 now at 174E will be moving to 180E shortly.

No home DTH subscriptions

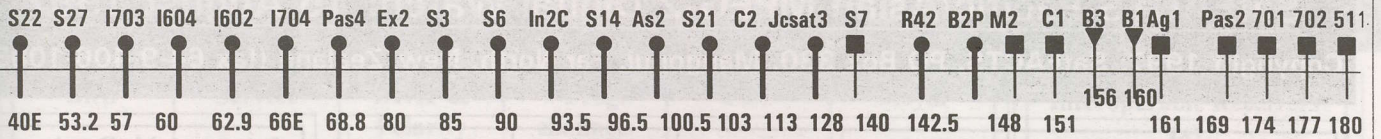

**OPTUS B3
156E
(Ku only)**

ABC WA	1425/Vt B-Mac
Central ABC HACBSS	1393/Hz B-Mac
Imparja	1351/Vt
GWN	1297/Vt
Net 9, Sky specials	1233/Vt B-Mac
OptusVis. (tests)	1250/Hz (MPEG)
ABC NT/ Imparja N.T.	1201/Hz (centre) B-MAC
Galaxy	1137/Hz Irdeto Mpeg 2
Galaxy	1073/Hz Irdeto Mpeg 2
ABC SA	1041/Vt

Optus A3/152E(a)

ATN7png	1297/Vt
ATN7png	1430/Vt

a/occasional use

**Palapa C2 Ku
(seen South
equator)/113E**

Test bars	11.148/Vt
-----------	-----------

**MeaSat 2
148E**

Tests	1065Hz*
-------	---------

* Colour bars, audio 6.8;
C-band covers
Australia, NZ

(a) B-MAC encrypted, no access available; (c) MPEG, encrypted, access may be possible (d) B-MAC, subscriptions available in some geographic areas.

**OPTUS B1
160E
(Ku only)**

Net 9, Sky feeds	1425/Vt B-Mac
Data	1402/Hz
QSTV	1377/Hz B-Mac
SE ABC HACBSS	1370/Vt B-Mac
SE SBS HACBSS	1344/Vt B-Mac
NE SBS HACBSS	1339/Hz B-Mac
NE ABC HACBSS	1313/Hz B-Mac
Sky Channel	1296/Vt B-Mac
ABC Radio	1276/Hz (digital)
OmniCast	1270/Vt (FM/FM)
ABC feeds	1247/Hz Pal
Sky Nz (sport)	1245/Vt VidCrypt
Sky Nz (Orange)	1218/Vt VidCrypt
Net 10	1182/Vt E-Pal
Net 9	1180/Hz E-Pal
Net 10 feeds	1155/Vt Pal
QTQ9	1145/Vt
Net 7	1120/Vt E-Pal
Net 9 feeds	1091/Vt Pal
Aurora MPEG-2	1076/Hz (tests)
CAA air to ground	1009/Vt Nbfm

**PAS-2
169E
(C + Ku)**

CCTV	1433.5/Vt (Sa9223)
PAS2 tests	1405/Hz
Value Ch.	1400/Vt
Discovery PowerVu	1374/Hz (Sa9223)
ESPN	1288/Vt B-Mac
MPEG-2 PowerVu Sylmar	1249/Hz (Sa9223)
TNT+ (1/2Tr)	1218/Vt B-Mac
CNN+ (1/2Tr)	1183/Hz
FoxSports	1161/Vt (SA 1.5)
NHK	1115/Hz
Filipino Channel	1060/Hz (GI 1.5)
NBC Mux MPEG	1057Vt (Philips)
MPEG-2 PowerVu HonKong	1002Vt (Sa9223)
TCS Sing.	967/Hz

PAS-2 Ku

Telstra Bendigo	12.321V (MPEG)
Napa TC	12,415V
H-Life	12,582H
Super Ch Taiwan	12,485H (MPEG)
Bloomb.	12.642V
K-TV	12,735V (MPEG)

Agila 1, ex-Rimsat R41
at 161E, Palapa C1 at
150.5E and B2P at
144E are functional and
some narrow band
services (non-video) and
testing has been
reported.

**Intelsat 701
174E**

Feeds	963
Feeds	984

**Intelsat 702
177E**

AFRTS	973 (PowVu)
Feeds	984
Space TV Sys	12.612V (MPEG)

**Intelsat 513
177W**

Feeds	963
Feeds	984

(513 Ku)

Service	RF Freq.
US Nets	10.980V
NBC	11.015V
Feeds	10.510V

Ku Services

Intelsat Ku band
services shown here
are boresighted to
Japan and nearby
Asia, have not been
reported south of
equator. At boresight,
signals of < 2m levels.

TDRS5 / 174.3W

Fuji TV	1305 Hz
BBC World	1163Hz MPEG

**Intelsat 511
180E(W)
+/- 3.1deg.**

TVNZ	964/Dmv 3000
TVNZ	972/Dmv 3000
TVNZ	980/Dmv 3000
TVNZ	988/Dmv 3000
Occ Vid.	1,020**
9 Aust.	1,025
SCPC	1,054 **
RFO Tahiti	1,105
Asian	1,130
World- net	1,175
NHK	1,225**
ABC Oz	1,256
7 Oz	1,274
10 Oz MPEG	1,385 (PwRvu)
Keystone	1,432

* RHC & LHC
** LHC only

(511 Ku)

NHK	11.135H
CBS	11.475H
CNN	11.508H

**TDRS5 "north"
only**

UPCOMING SATELLITE LAUNCHES

Filipino Agila 2 to 144E (August)
ApStar2A to 77E
AsiaSat 3 to 105.5E (November/December)

Pas-2 Imparjal/ABC

12.30V + Ch.3 ABC Radio
+ Ch.4 Imparjal Radio

SatFACTS Pacific/Asian MPEG-2 Digital Watch: 15 August 1997

Copyright 1997: SatFACTS, PO Box 330, Mangonui, Far North, New Zealand (fax 64-9-406-1083)

Bird	Service	RF/IF & polarity	# Prog channels	FEC	Msym
1704/66E	CFI	4055/1095 RHC	4	3/4	27(.500)
PAS-4/68.8E	Walt Disney	3982/1168 Hz	2	3/4	6(.632)
	ISkyB	12.164 Vt(1)	20+ TV	1/2	20(.000)
Thaicom 78.5E	UTV	3920/1230 Hz	6TV (#1)	3/4	27(.500)
	UTV/MCOT	3880/1270 Hz	6TV (#2)	3/4	27(.500)
Measat 1/91.5	India Bouquet	12284/12346Vt	10+TV?	7/8	30(.000)
As2/100.5E	European Bouquet	4000/1150 Hz	6TV, 12 radio (#3)	3/4	28(.125)
	Hubei TV (HBTV Main)	3854/1296 Hz	2	3/4	4(.418)
	Hunan TV (SRTC)	3847/1303 Hz	1	3/4	4(.418)
	Guandong TV (GDTV)	3840/1310 Hz	1	3/4	4(.418)
	Inner Mongolia TV Zizhiqu	3828/1322 Hz	2	3/4	8(.397) (1-China) (2-Mongolia)
	APT London	3800/1350 Hz	1	3/4	5(.631)
(This service REALLY does exist!)	WTN Jerusalem/London	3790/1360 Hz	1	3/4	5(.631)
	WTN London	3786/1364 Hz	1	3/4	5(.631)
	Liaoning TV (Service 2)	3734/1416 Hz	1	3/4	4(.418)
	Jiangxi TV (JX Sat TV)	3727/1423 Hz	1	3/4	4(.418)
	Fujian TV (SETV)	3720/1430 Hz	1	3/4	4(.418)
	Henan TV Zenghou	3713/1437 Hz	1	3/4	4(.418)
	Henan TV Main	3706/1444 Hz	1	3/4	4(.418)
As2/100.5E	Sky Racing	4015/1135Vt	3TV	1/2	18(.000)
	STAR TV (Hong Kong)	3900/1250 Vt	5TV (#4)	3/4	28(.100)
	"QQQ" China (Shaanxi)	3813/1337 Vt	1, 1 Radio	3/4	4(.418)
	Guangxi GXTV	3805/1345 Vt	1, 1 Radio	3/4	4(.418)
	Rebar TV Taiwan	3785/1365 Vt	4TV (#5)	3/4	18(.000)

Interoperable Receivers (a)
N163/17X/2X, HS-100C
N2X
DVS211 (probablyt FTA now)
HS-100C, Philips, probably others (some chs now CA)
HS-100C, Philips, probably others (some chs now CA)
Philips
DMV, HS-100C, Gng, N163./17X/2X, N2000, P400(b), P500, Pn520/630, Sk888
HS-100C, N163/17X/2X, N2000, Ph3950/11
HS-100C, N163/17X/2X, N2000, Ph3950/11
HS-100C, N163/17X/2X, N2000, Ph3950/11
HS-100C, N163/17X/2X, N2000, Ph3950/11
DMV, HS-100C, N163 /17X/2X
DMV, HS-100C, N163/17X/ 2X
DMV, HS-100C, N163/17X/ 2X
HS-100C, N163/17X/2X, N2000, Ph3950/11
HS-100C, N163/N17X/2X, N2000, Ph3950/11
HS-100C, N163/17X/2X, N2000, Ph3950/11
HS-100C, N163/17X/2X, N2000, Ph3950/11
HS-100C, N163/17X/2X, N2000, Ph3950/11
Pace DVS-211 (CA)
Pace DVS211(CA), DMV, N163*/17X+/2X
HS-100C, N163/17X/2X, N2000, Ph3950/11
HS-100C, N163/17X/2X, N2000, Ph3950/11
Pv9223 (CA) [Video inverted?]

*/ Nokias have 20 second lock-up on NTSC, (some versions of) HSS-100C may have lip sync problems with NTSC.

NAP Sat 2 - Ku vt 12377
 AS2 - 3760 / 10.000 3/4 - STAR BIRD - ATHENS? Pal
 3940 / 26.655 4/3 - HALLMARK / vt

SatFACTS Digital Watch: 15 August 1997 ♦ continued

Bird	Service	RF/IF & Polarity	# Prog. channels	FEC	Msym
(As2/100.5E)	Myanmar TV	3766/1384Vt	1TV	7/8	5(.080)
	STAR TV Hong Kong	3700/1450 Vt	8TV (#6)	3/4	28(.100)
C2/113E	Star Indovision	3500/1650Hz 3580/1570Hz	20 TV (#7)	7/8	26(.850)
	MegaTV	3780/1370Vt	5TV (#8)	3/4	27(.500)
	Tiernan-1	3926/3935Hz	1TV	3/4	4(880)
AP1/138E	Reuters	3732/1418Vt	1TV, data	3/4	5(.632)
Optus B3 156E	Galaxy	12.438Hz 12.373Hz	20+TV (#9)	3/4	29(.473)
Optus B3 156E	Optus Vision	12.550Hz	16TV, 8 radio (#9A)	3/4	29(.473) 30.000?
Optus B1 160E	Aurora (MPEG test)	12.376Hz 7	5+ TV (#10)	3/4 2/3	30(.000) 27.50
	ABC Exchange	12.539Hz 12.548Hz 12.557Hz	1 each	3/4	6(.980)
PAS-2 169E	Telstra Bendigo	<u>12.321</u> Vt 300	2TV, 2 radio (#11)	1/2	10(.138)
	MTV Asia	12.585Vt	8TV	3/4	29(.100)
	Hong Kong PowerVu	4148/1002 Vt	8TV (#12)	2/3	24(.430)
	NBC Hong Kong	4093/1057 Vt	7TV (#13)	3/4	29(.473)
	JET Singapore	3962/1188 Vt	2TV (1-Ntsc, 2-Pal)	1/2	13(.740)
	CCTV China PowerVu	3716.5/ 1433.5 Vt	3TV (#14)	3/4	19(.850)
	TCS Singapore	4183/967 Hz	2TV (#15)	1/2	6(.620)
	AAR-ART/ RAI Int	4153/997 Hz	3TV (#16)	3/4	5(.632)
	PAS-2 feeds	3940/1210 Hz	2TV(NTSC)	2/3	6(.620)
	California PowerVu	3901/1249Hz 12425Vt	8TV (#13)	3/4	30(.800)
	Satcom 1-6	3862/1288Hz	6TV	7/8	19(.465)
	Disney/Aust.	3804/1346Hz	1TV	5/6	21(.093)
	Discovery Singapore	3776/1374 Hz	7TV (#17)	3/4	19(.850)
	UCTV/PAS	3718/1432 Hz	1TV	2/3	6(.620)
I702/177E	AFRTS	4177/973 LHC	8TV, 12 radio & data (#18)	3/4	28(.000)
	SPACE TV Systems	12.612/1312 Hz	13TV, 11 radio (#19)	3/4	26(.694)
I511/180E	TVNZ Gennet (feeds)	4186/964, 4178/972, 4170/980, 4162/988	1 TV typical each	3/4	5(.632)
	Canal Plus	4096/1054 LHC	1TV (?)	3/4	34(.368)

Interoperable Receivers (a)
HS-100C
Pace DVS-211 (CA), N163/17X/2X
Pace DVS-211 (CA)
N2X/DVS-211(CA)
N2X (occasional use)
N163/17X/2X
Gng, P400, P500, Pn520, Pn630, Sk888 (c)
(when testing is over, only IRDs with CAM)
N163/17X/2X, Pv9223
Pv9223, HS-100C, N2X (FTA)
Pv9223, N2X (Pv CA)
Unknown- Asia beam only
Pv9223, HS-100C(*), N2X* (some FTA)
HS-100C, Gng, N163/17X/2X, P400 (b), P500, Pn520, Pn630, Sk888
Pv9223 (CA)
Pv9223, HS-100C, N163/17X/2X (FTA)
Pv9223, HS-100C N17X/2X (FTA)
Pv9223, N17X/2X, (continues FTA)
Pv9223, N2X (usually FTA)
Pv9223, HS-100C (*) N17X/2X (*), (some FTA)
Pv9223 (CA)
Pv9223 (CA)
Pv9223, HS100C, N2X (occasionally Ch. 2 FTA)
N2X, PV9223 (feeds)
Pv9223 (CA)
Pv9223, HS100C, P2X (some chs now CA only)
DMV, N17X, 2X (not all channels hot at all times)
Sagem ISD 2050 (?) (CA)

0309 Pal - 1385 - 29.900 7/8ms
 1003
 5 TOTAL - #5 with CA -

SatFACTS MPEG-2 Digital Watch: 15 August 1997 ♦ Support Data

Receivers: (a) By our definition, a receiver is deemed "fully interoperable" when it will turn on and routinely receive the service in question with no persistent glitches, no special tricks (such as loading software from an external source). Receivers in abbreviated listings are those that have shown these qualities for the transmission service listed. There is a time lag of up to 30 days after introduction of new receivers before sufficient data is accumulated for inclusion here. Nomenclature: **DMV** is DMV/NTL 3000 (a professional model receiver); **HS-100C** is Hyundai HSS-100C, designed for China; **Gng** is Grundig DTR1100 (manufactured by Panasat - see SF#31, p. 15); **N163** is Sweden sourced Nokia 9500 S with version 1.63 software; **N17X** is German/European Nokia "d-box" software modified for C-band use; **N2000** is Nokia sourced IRD created for Chinese SCPC market with AsiaSat 2 and Intelsat manual search software; **N2X** is May/after 1997 version of 9500 S; **Pace DVS-211** is Indovision (+ Sky Racing) CA only receiver also used by Sky on As2; **Ph3950/11** is rack mount Philips DVB IRD created for China SCPC project; **P400** is Pace DGT400; **P500** is Pace DVR500; **Pn520** is first version Panasat (July 1996); **Pn630** is latest version Panasat (February 1997); **Pv9223** is PowerVu by Scientific Atlanta; **Sk888** is Skandia DigiScan. (b) P400 (DGT400) will only work with EBB (et al) when it has not been over the air enhanced (upgraded); (c) SK888 will not work with conditional access (pay) services.

Bouquets: 1) **Thailand UTV:** (1) CNN, (2) TTV, (3) ESPN, (4) HBO, (5) Ch. 5, (6) itv; 2) **Thailand UTV/MCOT:** (1) Ch. 9, (2) Discovery, (3) Ch. 3, (4) TNT, (5) Star Sport, (6) Ch. 7; 3) **European Bouquet.** (1) Deutsche Welle, (2) MCM, (3) RAI International, (4) RTVE, (5) TV5 Paris, (6) [when operating] Deutsche Welle special programme channel with MediaNet VBI included [lines 10-15, requires DMV M2/Pro/Txt board inserted in 3000 series receiver]; Radio (1) DW#1 (stereo), (2) DW#2 (stereo), (3) DW#3 (stereo), (4) YLE (left) & RCI (right), (5) SRI (l) & WRN (r), (6) REE, (7) DW#1 (stereo), (8) DW#2 (stereo), (9) DW#1 (stereo), (10) NN RA6, (11) NN RA8; 4) **STAR TV Hong Kong.** (1) Sky News London, (2) Sports Contribution, (3) Channel [V] International, (4) Star Movies Japan [NTSC], (5) Star Plus Japan [NTSC]; 5) **Rebar Taiwan.** (1) "U1" [movies], (2) "U2" [news], (3) "U3" [sport, cartoons, general entertainment], (4) "Rock TV"; 6) **STAR TV Hong Kong.** (1) Channel 6, (2) ESPN Contributory, (3) Racing Ch., (4) Star Movies SEA, (5) Star Chinese, (6) NBC, (7) CNBC, (8) Sky News, (9) VIVA Cinema; 7) **Indovision.** (1) HBO Asia, (2) STAR Movies SEA, (3) Film Indonesia, (4) MGM Gold, (5) ESPN Asia, (6) STAR Sport, (8) Channel 'V' International, (9) Channel 'V' Asia, (10) RCTI, (11) STAR +, (12) Discovery, (13) STAR Movies and NBC Asia, (14) Phoenix Chinese, (15) CNN, (16) BBC World, (17) CNBC, (18) Cartoon + TNT, (19) Preview 1, (20) Preview 2; 8) **MegaTV.** (1) CNNI, (2) Discovery, (3) ESPN Asia, (4) HBO Asia, (5) Cartoon + TNT, [(6) MGM Gold, (7) Cinemax (6-7 may not be operating)]; 9) **Galaxy.** Presently 20+ programme channels. 9A) Optus Vision tests of 16 programme channels, programming decisions to be finalised; 10) **Aurora.** (1) SBS NT, (2) SBS NE, (3) SBS, (4) Sky News, (5) ABC WA; 11) **Telstra Bendigo.** (1) Imparja, (2) ABC, (3/15) Hinrich's Audio; 12) **Hong Kong PowerVu.** (1) CTN 1, (2) CTN II, (3) TVBI Hong Kong, other feeds [NTSC], (4) **Ad-hoc 1 PA [PAL]**, (5) **Ad-hoc II [NTSC]**, (6) **ABN**, (7) CTN II, (8) CTN; 13) **NBC Hong Kong.** (1) CNBC, (2) CNBC Mandarin A, (3) NBC Asia, (4) colour bars, occasional feeds, (5) CNBC Mandarin B (6) NBC "2" Asia/Taiwan, (7) Colour bars, "future" use; 14) **CCTV China.** (1) **CCTV4**, (2) **CCTV3** [(3) **CCTV tests**, (4) **CCTV4**, (5) **CCTV5**, (6) **CCTV8**]; 15) **TCS Singapore.** (1) **TCS Test**, (2) **TCS Default** [repeats channel 1]; 16) **SCPC3.** (1) ad-hoc use, (2) AAR/ART, (3) RAI International; 17) **California PowerVu.** (1) **CMT(NTSC)**, (2) **CBS feeds**, others including CTV Canada (NTSC), (3) [Greece] Antenna 2 (NTSC), (4) **EWTN (NTSC)** global Catholic radio, ch. 2, (5) **BBC World (NTSC)**, (6) **Bloomberg Financial (NTSC)**, (7) Golf Channel (NTSC), (8) **ESPN (NTSC)**; 18) **Discovery.** (1) Disc. Aust/NZ, (2) **Disc. default**, (3) Disc. Japan, (4) Disc. SE Asia, (5) Disc. Taiwan, (6) Disc. Philippines, (7) Disc. China; 19) **AFRTS.** (1) News, Sports [ACII, CW, RR, 9.6 kbps, TV], (2) Spectrum [Urban, 64 kbps], (3) AFN Pacific [TV], (4) Channel 1 - Mirror [TV], (5) AFN Korea [contingency, 1.536, TV], (6) The Jim Lambert Test Channel [!!!], (7) EPG, voiceline, (8) EPG, u/i voiceline, (9) AFN Atlantic [Top 40, HR, NPR, TV], (10) AFN Americas [Top 40, TV], (11) AC1, (12) Country, (13) Adult Rock, (14) NPR [US National Public Radio], (15) Urban, (16) Pure Gold, (17) Top 40, (18) Hard Rock (19) Contingency.; 20) **SPACE Systems** (in loading order). (1) P904[Exxtasy], (2) P200(CA), (3) P201(FTA), (4) P202(FTA), (5) P203(barker), (6) P204(barker), (7) P205 (barker), (8) P206(CA), (9) P207(FTA), (10) P208(barker), (11) P501(audio/data), (12) P502(audio/data), (13) P503(audio/data), (14) P504 (audio/data), (15) P505(audio/data), (16) P506(audio/data), (17) P507(audio/data), (18) P508(audio/data), (19) P509(audio/data), (20) P510 (audio/data), (21) P511(audio/data), (22) P3801(CA), (23) P3802(CA), (24) P7777(CA). NOTE: Listings in **bold face** are PowerVu transmissions that are typically (but not always) FTA (free to air). Underlined Space TV Systems are typically FTA.

MPEG-2 DVB RECEIVERS: [Data here is believed accurate; we assume no responsibility for errors in this volatile area!]

DMV/NTL 3000. Skandia Electronics Pty Ltd (tel 61-3-9819-2466)

Espano. Antares Satellite (tel 61-7-3205-7574) Note: Still not available as of August 10.

Grundig (Gng) DTR1100. Av-Comm Pty Ltd (tel 61-2-9949-7417)

Hyundai-TV/Com. Model HSS-100C is officially available from Pacific Satellite (tel 61-7-3344-3883) and Skandia Electronics (tel 61-3-9819-2466); Skandia offering "improved software version by "late August."

Nokia 9500 S (V1.63). This version is no longer available although it had ability to identify Msym and FEC parameters of unknown carriers. (V1.7X) was a German language "d-Box" version originally imported by OPAC; it functioned with the same parameters as the V1.63. (V2.X; 2.233/e3, 2.034 and others perhaps not yet identified) are current (after June/July) software versions that allow virtually unlimited stacking of bouquets and programmers and for at least the 2.233 version also allows limited red menu correction of NTSC glitch (see SF#36, p. 6). Sources known include: AV-COMM Pty Ltd (Tel 61-2-9949-7417); Pacific Satellite (61-7-3344-3883), SCITEQ (61-8-9306-3738). AV-COM has macro-command IR remote that expedites 'red menu' operations for e3 version 9500 S. (see SF#36, p. 32).

Nokia "d-box" (V1.7X) suitable for C-band use. Instructions, on-screen prompts may be in German. No longer available.

PACE DVS-211. Officially available only through Sky (racing) Australia (Bob Pankhurst tel 61-2-9451-0888).

PACE DGT400. Through Galaxy offices, Australia.

PACE DVR-500. Bay Satellite TV Ltd. (tel 64-6-843-5296); also supplied by NBC to affiliates.

Panasat 520 (Pn520). OPAC Pty Ltd (tel 61-2-584-1233); no longer available.

Panasat 630 (Pn630). Antares Satellite (61-7-3205-7574); will be replaced by 635 after September 15.

PowerVu D9223. Scientific-Atlanta (Sydney) Tel 61-2-9452-3388; BaySat (tel 64-6-843-5296)

SAGEM ISD2050. SAGEM SA, Mrs. Salima ALAOUI (tel 33-1 40 70 63 63)

Samsung VS-2000 (ver 1.31). Pacific Satellite (tel 61-7-3344-3883)

SK888. Skandia Electronics Pty Ltd. (tel 61-3-9819-2466)

WITH THE OBSERVERS

AT PRESS DEADLINE

Herbalife PAS-2 Ku FTA analogue has settled to M/W/F sked 12.330 Vt 1100-1200 UTC. NBC Asia has added second CNBC Mandarin (programme channels 2 and 5). Agila 2 via Long March launcher scheduled 1800 UTC August 13th if all stays on schedule; no "live" coverage likely.

In our July 15th report covering the appearance and testing of Mandarin/Asian (language) SPACE TV Systems (I702, 177E) we observed that programme channels then in use were in a state of flux and subject to daily change. On August 4th it all settled down as SPACE began real-world testing of their Viaccess conditional access system. As SF goes to press, 24 programme channels are identified (Nokia e3) with a mixture of conditional access (6 programme services, including Exxtasy), audio/data (11 dedicated programme channels), non-CA barker/promotional channels (4) and still free to air programming channels (3); see updated list, p. 28.

Australian agent **Ming Leu**, a long time SatFACTS subscriber and member of our SPACE Pacific trade association, advises:

"The SPACE signals work very well with a 0.9m dish without freeze framing using the XSAT CD.TV200 receiver (a Thomson IRD). With Nokia and Hyundai IRDs, though, occasional freeze framing occurs. (Unfortunately), some (Australian) dealers are already mis-selling receive systems to the public with promises that no subscription fees will be required. SPACE TV has placed a notice in their promotional channel transmission to warn consumers about such misleading dealer statements."

The warning notice appears here (upper right). That dealers might be selling I702 Ku band systems to unsuspecting Australian Asian viewers and misleading them by claiming no subscription fees will be required - after the very thorough report on the actual status of this service in the July SatFACTS - is frightening. As for the status of the controversial Exxtasy

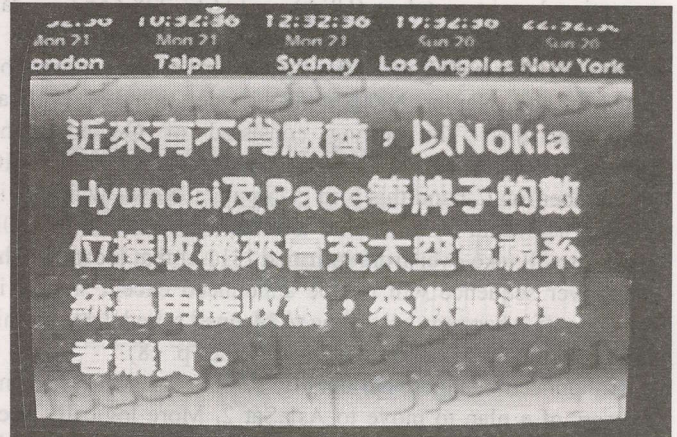

SPACE Systems "warning" to viewers not to buy Nokia, Hyundai nor Pace receivers

adult film channel, the President of Exxtasy (**Stuart Duncan**) sat in our SF offices on August 7th and told us:

"Our arrangement with SPACE TV Systems is that we share revenues from subscribers to the adult service. Neither we nor they intended for there to be free to air transmission of our service for even one minute. That it happened is regrettable and once we learned about this, steps were taken to stop it. The present tests (of the CA system) are scheduled to continue through August. We would hope to be in a position to offer service into areas where there are no regulatory difficulties before the end of September. There are two obstacles at this time. One, the IRD availability has not yet reached production

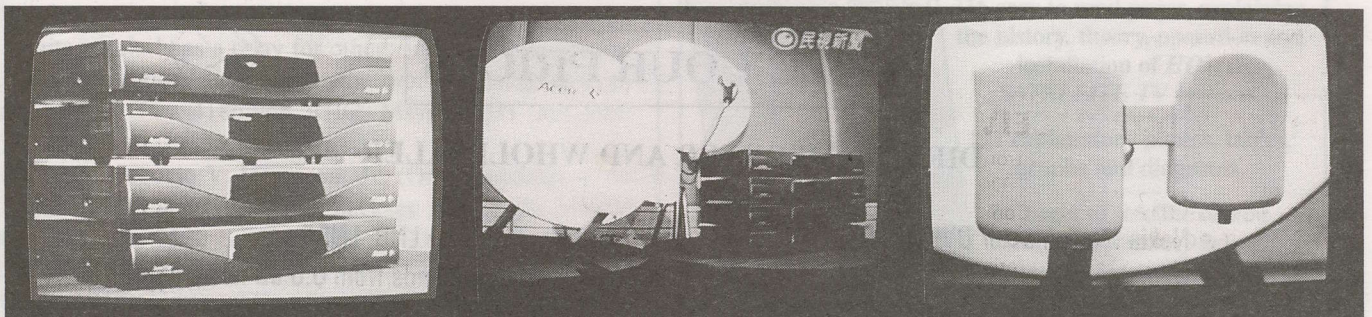

SPACE Systems IRD units (left) as displayed on barker channel promotional tape; "Acer" satellite dishes (offset-left, prime focus right); Offset LNB mounted on offset dish for North American reception of SPACE Ku feed on Galaxy 4 (99W) with dish system originally installed for DirectTV DBS (101W).

WITH THE OBSERVERS: Reports of new programmers, changes in established programming sources are encouraged from readers throughout the Pacific and Asian regions. Information shared here is an important tool in our ever expanding satellite TV universe. Photos of yourself, your equipment or off-air photos taken from your TV screen are welcomed. TV screen photos: If PAL or SECAM, set camera to f3.5-f5 at 1/15th second with ASA 100 film; for NTSC, change shutter speed to 1/30th. Use no flash, set camera on tripod or hold steady. Alternately submit any VHS speed, format reception directly to SatFACTS and we will photograph for you. Deadline for September 15th issue: September 5 by mail (use form appearing page 34), or 5PM NZST September 6th if by fax to 64-9-406-1083.

levels and until we have sufficient receivers to handle both SPACE TV's needs and our own, we cannot launch a commercial venture. Two, we may well decide that our 'public channel' will be R-rated and access to the triple-X service will only be through an R-channel subscription (see p. 20, this issue - ed.)." SPACE Pacific members will receive an extensive insider report update on this situation before the end of August (SPACE Membership Notes, Vol. 3, No. 1 dated August 25). Or, you can contact Fred Pantalone (VP of operations) at tel (USA) ++613-228-6557, fax ++613-228-7717, e-mail fpantalone@xrc-com.com.

Intelsat 802, testing at 167E (first observed and reported by Stu McLeod, Napier, NZ) should be operational at 174E as you read this. The testing consisted of C-band blank (unmodulated) carriers at approximately 960 and 1060IF, LHC (remember, on C-band this bird is circular). Now - with 802 in place, 701 would be turned off and manoeuvred east to 180E where it will take over from infirmed I511 at that location. The hand-over sequence will not be announced except shortly in advance. If it happens according to planned scheduling, by this time next month 511 should be history (see p. 18).

Announced changes: No details. EMTV (142.4E) is telling viewers of a plan to move to AsiaSat 2. More logically, they would go to AsiaSat 3 after it launches in November/December. They are also saying that eventually they will convert to MPEG-2, but not soon (EMTV is now filling non-regular programming hours with a feed from TVSN). GMA (C2) is saying they expect to change satellite (or delivery method - the message is unclear) August 10th. There has been a (General Instrument) Digicipher 1.5 MPEG service sharing the GMA transponder from day 1 (on C2); another Filipino service (People's TV Network - PTV4).

During July Observer Robin Colquhoun found a second MPEG-2 service (identifying as Tiernan-1) with a remote site backhaul feed also active (3936 MHz, horizontal - found with Nokia e3); FTA, NTSC. The carrier level; of the PTV4 and Tiernan-1 MPEG services on occasions is quite spectacular and when they are 'hot' the GMA service reduces by more than 3 dB and develops noise in the video (answer is to narrow up the GMA receiver IF setting).

Another new MPEG-2 (SCPC) service is located on PAS-2, Hz, 3717.75 MHz (Msym 6.620, FEC 2/3). Sometimes it has PanAmSat Napa test slide, other times news feeds (FTA, NTSC).

Numerous observers report WCETV, a Chinese gambling channel, on PAS-2 FTA analogue (3900/1250 Vt) from 1300 to 2000 UTC daily. Also check out 3815/1335 Vt during the same period for AB Asia, a similar format service.

Garry Cratt and others report new AsiaSat 2 services as follows: Sharing 3680/1470 Hz with Mongolian TV (Tuesday to Sundays 0800-1400 UTC) is Sima-yeh-Moghavemat (Vision of Resistance) Sunday to Friday 1930-2030 UTC and Baztab TV from Iran Thursday to Monday from 1700 - 1900 UTC.

Francis Kosmalski (Auckland, NZ) reports an unmodulated carrier, good level, from what appears to be 150.5E (Palapa C1); 3820/1330 Hz. Anyone else seeing signs of life from C1?

Steffen Holzt (New Caledonia) reports Optus Vision tests on B3 12.550 (Hz) have a measured carrier to noise ratio of 9.5dB with a 3.6m micromesh Orbitron dish and 0.6 dB Gardiner LNB.

Les Brooks (Alice Springs, NT) forwards an announcement by Australia's Golden West Network of their plan to switch from Optus analogue delivery to PAS-2 MPEG delivery "in

ACESAT

(ESTABLISHED 1983)



CHECK OUR PRICES

DIRECT IMPORTER AND WHOLESALE

- Nokia Mediamaster DVB 9500 S
- Hyundai HSS-100C
- VideoCrypt decoders and IRDs
- Chaparral Monterey 20
- Chaparral MC115
- Analogue Receivers - 320 Channels ++
- Norsat range LNB, LNBF
C, and Ku bands from 0.6 dB noise figure
- Full range mesh and solid dishes
- Used products-
-Dishes from \$50
-LNBS from \$50
-Receivers from \$100

• Receive - German, French, Spanish, Italian, Egyptian, Portuguese, Chinese, Filipino, Malaysian, Greek, Indonesian, Japanese - plus UK / America / Most Asian countries!

FULL RANGE OF OTHER PRODUCTS - ALL ENQUIRIES ANSWERED

NEW

Copy of *The World of Satellite*
TV- all orders over \$100

ACESAT SATELLITE CORP PTY Ltd ACN 002 152 034

7/32 Endeavour Road, PO Box 428 Caringbah NSW 2229 Australia

Tel 61-2-9526 2411 Fax 61-2-9526 2206 Email: acesat@aic.net.au

SatFACTS August 1997 ♦ page 30

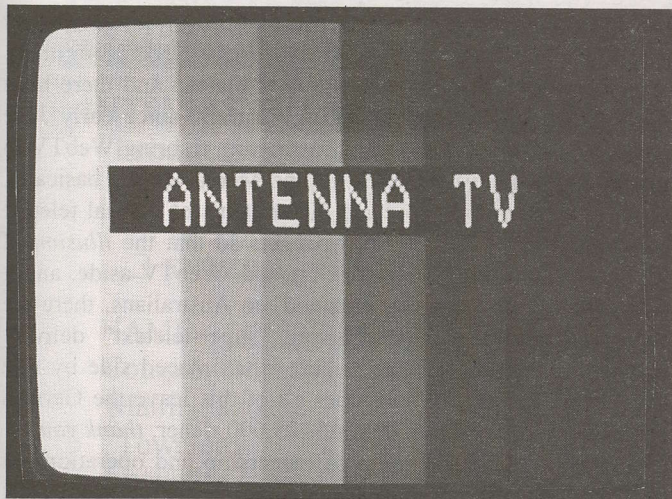

Greek Antenna TV ran (briefly) FTA on PAS-2 California bouquet, then went CA. Does anyone know how to subscribe to this service?

November." The GWN announcement adds they will cease their Optus B-MAC analogue service "at the end of January." GWN claims a "digital set top box or receiver will be available at a cost of approximately \$1,000 in November." Details from GWN Director of Engineering Hugh James tel 61-8-9792-2803.

Observer **D. Morris** (Bangkok, Thailand) reports his Hyundai will no longer receive (FTA) Disney on PAS-4, APTV and Star TV on As2. Readers are urged to carefully read Robin Colquhoun's report in this issue (p. 6) which describes why a Hyundai, not equipped with a conditional access module, will bring up an advisory on screen ("This channel is scrambled") when in fact all that is happening is the (Disney) data stream is now asking the receiver - "Do you have a CAM (conditional access module)?"

Stu McLeod (Napier, NZ) reports that amongst the many idents he has seen come and go within the Television New Zealand 4 SCPC MPEG channels on I511, have been: BSKyB, CRY.E093 M4, BSKyB, CNY.E093 M, BSKyB, CRY.FO9M46." In fact, TVNZ sells their 4 SCPC channels on I511 quite regularly as a relay for others and over time you are likely to see almost anything in the world passing through these "portals" (try 4186/964 RHC, Msym 5.631 and FEC 3/4).

Observer **Gregorio V. Hermosa, Jr.** (Oman) updates us on the status of IRD and programme package sales in the Middle East. The Nokia 9500 S sells for US\$593 while the Panasat 630 is US\$630 (retail pricing). A no-name-brand IRD for use by Orbit Communications lists for US\$671 but is available at 50% discount (US\$335) if: (1) The buyer is a relative or friend (!) of a present subscriber, (2) Agrees to pay US\$50 per month for a minimum of 3 months (in advance) for programming, and, (3) the subscriber provides the dish, LNB and installation (currently US\$135 in Oman). This IRD is, of course, the SA D9232 (see SF#24, p. 31 for a photo and description). In June 1996 (one year ago) Orbit was selling this SA IRD, dish and LNB for US\$1,200. The D9232 is an MPEG 1.5 (not MPEG-2) receiver that includes an IR (remote) control and operates at a (factory fixed) Msym of 49.143 and FEC of 7/8. In effect, the package price has dropped from US\$1,200 to US\$470 in one year. Dare we suggest a similar reduction might occur with the D9223 in the next year? No - that is very unlikely!



- Trade supplier of
- Nokia Receivers
 - Orbitron Dishes
 - ADL Feedhorns
 - Gardiner LNB's
 - other satellite accessories

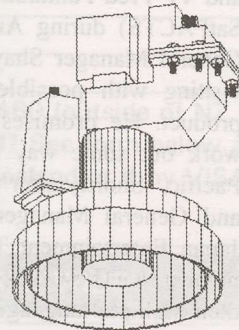

Phone: +61 8 9306-3738
 Fax: +61 8 9306-3737

<http://www.omen.com.au/~pmerrett>
 33 Kentia Loop, Wanneroo
 WESTERN AUSTRALIA 6065

NOT COMING TO A NEWSAGENT NEAR YOU

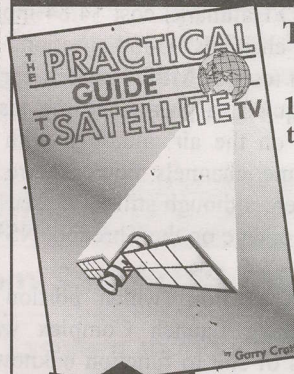

NEW!

THE PRACTICAL GUIDE TO SATELLITE TV

116 easy to read pages, explaining the history, theory, operation and installation of HOME SATELLITE TV systems.

121 explanatory photos, tables, graphs and diagrams.

46 pages of satellite orbital data, transponder loading, footprints for every satellite covering Australia and neighbouring countries and comprehensive glossary of terms.

AVAILABLE NOW - \$39

AV-COMM PTY LTD

A.C.N. 002 174 478

198 Condamine Street,
 Balgowlah NSW 2093

Tel: (02) 9949 7417/9948 2667

Fax: (02) 9949 7095

<http://www.avcomm.com.au>

✓ **YES GARRY, Please send me 1 x Practical Guide to Satellite TV priced at \$39 + \$5 p&p (NZ \$8 p&p)** Australian \$ only

Credit Card

Signature _____

Name: _____ Expiry Date: ___/___/___

Delivery Address: _____

Pcode: _____ Phone: _____

AT

Sign-off

Tid Bits

A world of contrasts. While Exxtasy President Stu Duncan and VP Fred Pantalone were visiting in New Zealand (and at SatFACTS) during August, Sony Entertainment Television's General Manager Shayam Haridas was also in New Zealand visiting with possible redistributors of his Indian (Hindi) product. He promises to return in September and hopes to work out some way to get SET into Indian homes in the Pacific. Shortly after this group left, Jim Hazama (Senior VP and General Manager of marketing) plus Sean Shibata of Japan Entertainment Television (JET on PAS-2) dropped in for a visit. They, too, are working out final details to launch their multiple-language service in the Pacific.

Speaking of launches - the cat is out of the bag regarding Sky (NZ) DTH planning. A bit of a disappointment, really: On May 1st (1998), they will formally light up their first MPEG transponder with 12 TV programme channels. Which 12? It seems Discovery and terrestrial horse racing service Trackside will share one, Orange and MTV will share another, Sky News and CNN will share a third, cartoons and TNT a fourth. The next four will be NZ terrestrial TV1, TV2, TV3 and TV4. Which gets us to 8. And NZ\$8 per week (plus gst, of course), or \$38.40 per month inclusive of gst. Then the subscriber can add Sport 1 and Sport 2 with basic and pay \$53.21 (gst inclusive) per month. Or, they can add HBO and Hallmark movie channels to the basic and pay \$58.05 per month. And if the customer takes all 12 services, it comes to (NZ) \$65.30 per month. Why should movies (HBO/Hallmark) cost \$4.84 more per month than high profile sport channels? Good question.

When the Aurora (Optus B1) tests of MPEG ceased early in August, the naysayers were quick to pronounce the tests "dead." Not so - they are back on the air, although with a modified encryption format (some channels now require a CAM equipped receiver to be seen, although still FTA; see p. 25). Officially, Optus blames the outage on the Thredbo, NSW landslide. Hey - whatever works.

Speaking of landslides. A portion (which portion - unknown) of the Chinese Xichang Launch Complex was buried by land movement. Status of site to function unknown at press-time but Filipino Agila 2 was scheduled to launch sometime around 13 August. If it got off, obviously the landslide didn't destroy anything important!

Enquiring minds want to know department. Do you wonder what happened to the much hyped Deutsche Welle MediaNet (on Air) Internet delivery service? We did and checked. A trio of Australians claim they paid more than A\$125,000 to acquire the "exclusive redistribution rights" to the service in Australia plus a long list of nearby countries (New Zealand included). Then, we are told, they arranged to test the service through a Queensland TV broadcaster and some quantity (around 100) of set top decoders was put into the field. And, that was several months ago. In the interim something called "WebTV"

has become the craze in America and Microsoft has purchased the WebTV rights world-wide (for a mere US\$425 million). WebTV carries MediaNet to the next plateau and there have been agents of Microsoft busy in Australia since early June creating a business plan and infrastructure to bring WebTV to that region of the world. WebTV and MediaNet are, basically, super-teletext - a way to cycle the contents of normal teletext transmitted (VBI data stream) packets so that the *illusion* of "connectivity to the Internet" is created. WebTV aside, and it will certainly be "smartly marketed" to Australians, there are serious doubts that any one-way "super-teletext" delivery system for Internet is really viable when placed side by side with "real" Internet. Where does all of this leave the German MediaNet project? More than A\$125,000 richer, *thank you*.

Panasat. Major shake-up of ownership and operation has occurred, no official announcements. South African plant formerly building 630 IRDs has been shut down, some segments of production line have been shifted to alternate South African facility. Interesting admission: "*Passivation material on silicon die*" within 630 power supply "*may be defective*." Translation: A quantity - some say 5%, some say much higher than 5%, of receiver power supply boards "cook" after shipment. After a two month "bake," some power supply "traces" go bad and the unit shuts down. There is a fix, and if you have a Panasat 630 that seems to have power supply problems, contact Antares Satellite Products (tel 61-7-3205-7574). They will repair units they originally sold, give advice to those who bought units elsewhere.

Hyundai MPEG-2 receivers purchased through Skandia Electronics can be upgraded to better performance for approximately A\$70. Although buyers purchased units with full knowledge they had some Australian/New Zealand "bad habits," the upgrading corrects the following: (1) Converts UHF modulator from 6.5 to 5.5 MHz audio subcarrier; (2) eliminates flashing and hang-ups when scanning channels, (3) allows direct NTSC or PAL selection (eliminates pause-pause correction for NTSC). Understand - this is an *upgrade*, not a warranty job and there is a charge. Details from (tel) 61-3-9819-2466.

Nokia 9500 S. After reading Robin Colquhoun's report on this receiver's red menu tricks (p. 11), you might wonder if there could be a way to speed up the 17 remote keystroke entries. There is. First you obtain a "universal remote" equipped with macro commands. Next you transfer the Nokia red menu commands to the universal remote. With "macro commands," up to 10 separate keystrokes are spit out of the "universal" to the Nokia at a time. Net result - two or three buttons on macro command remote and you have all of the Nokia red menu commands entered. If this is possible, why doesn't somebody offer a pre-programmed macro command remote, pre-set for Nokia use? Could be coming. Unfortunately, there are some pitfalls. Nokia remotes have significant "key bounce" and when entering the sequence of commands into the macro "universal" it is very easy to bounce yourself into unwanted, error commands while entering the called-for command.

Pay per chew. How many homes equipped to receive pay per view (via satellite or DTH) actually buy a major event? June's ear-chew in Las Vegas (Tyson-Holyfield) was bought by 5.6% of US West's MediaOne cable subscribers; 285,600 homes at US\$40 each for US\$11,424,000. Throughout USA, this would add up to US\$146,480,000 for a few minutes chewing. NOW you understand Murdoch's *passion* for sport!

THE YEAR OF SATELLITE EXPLOSION IN THE PACIFIC/ASIA!

INTELSAT 701 to 180E, I802 NOW AT 174E. PanAmSat Ku attracting Australian TV broadcasters. The D9223 NOW does FTA MPEG. AND we are entering our fourth year of service. Stay tuned with SatFACTS!

- ENTER my 12 MONTH subscription to SatFACTS starting with September 15th issue (rates below)
 ENTER my 36 MONTH subscription to SatFACTS starting with September 15th issue (rates below)

NAME _____

Company (if applicable) _____

Mailing address _____

Town/city _____ Country _____

Amount to send: 1 year - NZ\$50 (inside New Zealand) / A\$90 (inside Australia) / US\$60 (outside of NZ and Australia) or 3 years - NZ\$120 / A\$210 / US\$150 if by cheque. **VISA** or **Mastercard**? See form below and return with order. Return to: **SatFACTS, PO Box 330, Mangonui, Far North, New Zealand** or if by VISA or Mastercard fax to 64-9-406-1083

ALL SatFACTS SUBSCRIPTIONS ARE SENT VIA AIRMAIL - WORLD-WIDE!

USE THIS FORM ONLY WHEN CHARGING ON VISA/MASTERCARD

Please charge my **VISA/Mastercard** as follows:

- ONE Year of SatFACTS MONTHLY (NZ\$50, A\$90, US\$60)
 THREE Years of SatFACTS MONTHLY (NZ\$120, A\$210, US\$150)
 SATELLITE TELEVISION: The Booklet (NZ\$10, A\$12, US\$10)
 One Year of COOP'S TECHNOLOGY DIGEST (NZ\$125, A\$125, US\$125)

Indicate charge card type: VISA Mastercard

Name (as it appears on **VISA / Mastercard**) _____

VISA/Mastercard Number _____

VISA/Mastercard expiration date _____

Instructions: If ordering by mail, return this complete (3-part) card or a copy of same (to **SatFACTS, PO Box 330, Mangonui, Far North, New Zealand**); if order by FAX, send full card as a single sheet to **64-9-406-1083**

SUPPLEMENTAL MATERIALS from SatFACTS MONTHLY: Order Form

- SATELLITE TELEVISION:** The Booklet. Excellent introduction to home dish ownership for the layman, including major contributions from the father of geostationary satellites - famed science fiction writer *Arthur C. Clarke*. The perfect tool to help the satellite system seller explain home satellite TV to the layman consumer. From SPACE Pacific. NZ\$10/ A\$12 / US\$10, airmail.
- COOP'S TECHNOLOGY DIGEST.** For the really serious enthusiast, investor, business person in satellite television and allied leading edge technologies. Ten asparagus issues each year, jam-packed with information you will not find anyplace else. "Coop" routinely culls more than 60 publications world-wide, terribly expensive newsletters, Internet and his hundreds of private contacts to keep you right at the leading edge of technology on the **REAL** changes underway in telecommunications. Conveniently issued near the **first of the month**, creating an excellent time-line-filler between the mid-month issues of SatFACTS. Now in the 4th year, airmail world-wide. Normally NZ/A/US\$250 per year - for SatFACTS subscribers special **50% discounted** price of NZ/A/US\$125.

OBSERVER REPORTING FORM - CONTEST ENTRY - Due Sept 5

- NEW programming sources seen since Aug 1st: _____
- Changes (signal level, transponder, programming content) in pre-existing programming sources since Aug 1st: _____
- OTHER (including changes in your receiving system): _____

NOTE: Please use P1 - P5 code when describing signal levels and receiver IF/RF settings.

Your Name _____ Is this contest entry? _____
Town/City _____
Make/size dish _____ LNB _____ Receiver _____
Bonus Word Entry: _____ on page _____

July BONUS WORD - Jabberwocky p.30 -

MAIL TO: SatFACTS Monthly, PO Box 330, Mangonui, Far North, NZ or fax 64-9-406-1083

YOU COULD WIN A DYNASAT 300P or PALCOM SL7900RP!

SatFACTS is giving away two (2!) top of the line super receivers - the PALCOM SL7900RP and the DYNASAT 300P - to subscribers between now and February! This is a MONTHLY CONTEST and you must REGISTER with us as a contest entrant. Complete this card to receive the full set of Contest Rules and join the fun. A DYNASAT 300P could well be yours (next receiver to be given away October 5!).

I AM A SUBSCRIBER TO SATFACTS - Please mail to me my SatFACTS Reader Contest Rules!

NAME _____
Company (if applicable) _____
Mailing address _____
Town/City _____

Return card to: **SatFACTS Monthly**, PO Box 330, Mangonui, Far North, New Zealand
of fax to us at 64-9-406-1083

MEMBERSHIP IN SPACE?

Choose your level of participation from "Individual" or "Installer / Dealer" to "Cable/SMATV Operator" or "Importer/Manufacturer/ Programmer."

YES - Send details of SPACE membership, to ...

NAME _____

Company (if applicable) _____

Mailing address _____

Town/city _____



SPACE Pacific Ltd.
PO Box 30, Mangonui, Far North
New Zealand
Fax 64-9-406-1083

The DIGITAL Satellite TV Installation Handbook

by Mark Long

This newly released publication by the best-selling author of *The World of Satellite TV* provides a comprehensive guide to installing both analogue and digital TV systems. **The DIGITAL Satellite TV Installation Handbook** represents the basic concepts in a graphic intensive format that typically provides two illustrations for every page of text—more than 200 new illustrations are released here for the very first time. What's more, each chapter is concluded with a series of quick check exercises which provide readers with the opportunity to confirm their basic understanding of the material just covered.

Unlike other satellite publications which were written with Europe or America in mind, **The DIGITAL Satellite TV Installation Handbook** was specifically created for readers in the Asia/Pacific region. This ground-breaking new textbook, which was created with the cooperation *SPACE Pacific*, will serve as the official textbook of a new *Satellite Installer Certification Course* developed to serve the educational needs of this trade association's membership.

This handbook comes with a set of two computer disks for IBM compatible PCs which contain full-color charts, graphs, satellite footprints and other illustrations in a JPEG format that is compatible with many graphics software and Internet web browser programmes. Two satellite installation software programmes for PCs running DOS 6.0 are also included on disk.

This exciting new publication also is fully supported by a brand-new web site on the Internet at <http://www.mlesat.com>. Time sensitive data in the handbook will be periodically updated here as a service to this publication's readership.

CONTAINS TWO
DISKS FOR IBM
PC COMPUTER
SYSTEMS

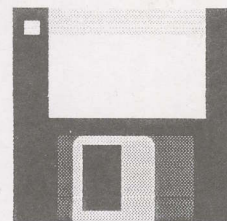

Table of Contents

Introduction

Chapter 1: Satellite Frequencies & Orbital Assignments

Chapter 2: Digital Video Compression Overview

Chapter 3: Feedhorns and Low Noise Block Downconverters

Chapter 4: Satellite Antennas

Chapter 5: Satellite Receivers & IRDs

Chapter 6: Satellite Installations

Chapter 7: Digital DTH Platforms in the Asia/Pacific Region

Glossary of Technical Terms

Exercise Answer Keys

Asia/Pacific Satellite Transponder

Guide & Frequency Plans

Other Satellite Reference Charts

Index

To save on shipping & handling fees and receive **SPACE Pacific** course certification, order this handbook and the new **Satellite Installations** videotape for US\$ 240.

The DIGITAL Satellite TV Installation Handbook

11

Satellite Frequencies & Orbital Assignments

CHAPTER 1
SATELLITE FREQUENCIES & ORBITAL ASSIGNMENTS

ME SAT.COM
<http://www.mlesat.com>

Figure 1-1: The geostationary satellite arc

THE DIGITAL SATELLITE TV INSTALLATION HANDBOOK

Satellite Frequencies & Orbital Assignments

Figure 1-2: The electro-magnetic spectrum

emspectr.jpg

The Electro-Magnetic Spectrum

The DIGITAL Satellite TV Installation Handbook

89

Digital DTH Platforms in the Asia/Pacific Region

CHAPTER 7
DIGITAL DTH PLATFORMS IN THE ASIA/PACIFIC REGION

ME SAT.COM
<http://www.mlesat.com>

There are now more than one hundred digital TV services on satellites serving the Asia/Pacific region. A complete list of all the available digital TV services on satellites serving the Asia/Pacific region can be found in Appendix B. Not all of these offerings are direct to home (DTH) TV services. Some of these transmissions are destined for cable TV distribution, while others are meant to be private circuits used by broadcasters for satellite news gathering activities.

Although many of the non-DTH channels are currently available to satellite dish owners, there is no guarantee that they will all remain available in the long run. The following chapter provides an overview of the digital DTH bouquets already in service and previews forthcoming satellite platforms in the region which are likely to provide digital DTH services in the near future.

THAICOM SATELLITES

On April 16, 1997, Arianespace launched Thaicom 3, the third in a series of dual-band communications satellites serving the southeast Asian Kingdom of Thailand. Thai satellite operator Shinawatra Satellite Public Co. Ltd. is using the new spacecraft to provide international communications services across a vast region stretching from central Europe and Africa to eastern Asia and Australia.

Built by Aerospatiale, Thaicom 3 is a Spacebus 3000A three-axis stabilized satellite equipped with twenty-four active C-band transponders, seven of which transmit in a semi global beam that spans virtually all the inhabited land masses visible from the satellite's orbital assignment at 78.5 degrees east longitude. The remaining eighteen C-band transponders connect to a regional Asian beam that encompasses India, southern China, and southeast Asia.

The fourteen Ku-band transponders on Thaicom 3 are divided between a high-powered spot beam centered over Southeast Asia and a screeble beam that is focussed onto the Indian subcontinent.

On May 25, 1997, Thaicom 3 was collocated with Thaicom 1 and

Thaicom 3 India Ku-band Downlink Beam

thai3_k2.jpg

Thaicom 3 Thailand Ku-band Downlink Beam

ERP contours: 56, 54, 53, 52, 50, 48, 46 dBW

Figure 7-2: Thaicom 3 Thailand downlink coverage beam.

Available for US\$ 59.95 plus
\$15 shipping & handling from:

SPACE Pacific

P.O. Box 30, Mangonui
Far North New Zealand
Fax: 64-9-406-1083

UNIDEN SATELLITE TELEVISION

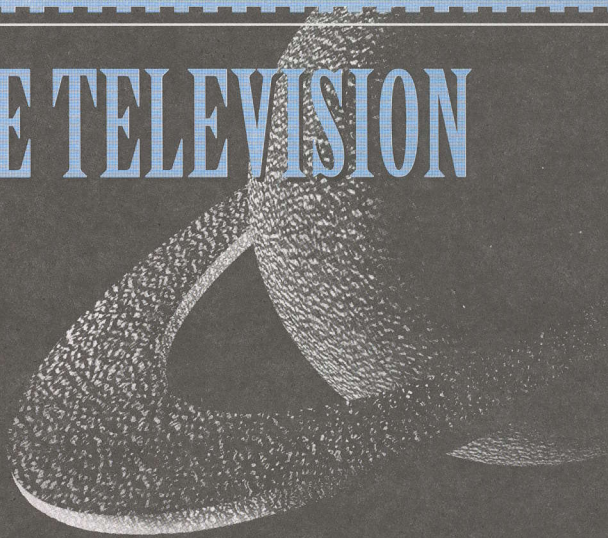

JUST IMAGINE...

Over thirty channels of free-to-air television from around the globe available throughout New Zealand. even in areas where present free-to-air or paid channels don't reach.

THIS IS NOT A DREAM, It's a reality. And it's available to your customers right now, with equipment costs that are probably a lot less than you would expect.

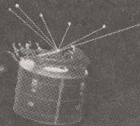

Uniden are about to launch their Satellite Television Package to dealers throughout New Zealand.

If you would like to find out how to profit from satellite television in New Zealand give Uniden a call.

After all, Uniden is one of the world leaders in satellite television technology.

UNIDEN SATELLITE TELEVISION

*Putting You Face To Face With
A World of Entertainment*

uniden®

a Clear Signal of What's Ahead

For more information Phone 0-9-273 8383 or Fax 0-9-274 0009

Uniden® is a registered trademark of the Uniden Corporation of Japan Ltd and is represented in New Zealand by Uniden (NZ) Ltd.