

11-07-97 1PM

update copy

Bob Cooper's

JULY 15 1997

# SatFACTS

MONTHLY

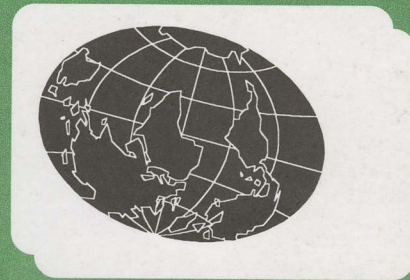

Reporting on "The World" of satellite television in the Pacific and Asia

## IN THIS ISSUE

**TRIPLE XXX  
Service  
On Intelsat 177E**

**Space TV Launches  
8 Chinese,  
More Coming**

**PAS-2 Ku Springs  
to Life - ABC &  
Imparja Testing**

- ✓ Latest Programmer News
- ✓ Latest Hardware News
- ✓ Latest SPACE Pacific Reports
- ✓ Cable TV Connection

Vol. 3 ♦ No. 35

Price Per Copy:  
NZ\$8/A\$9/US\$6

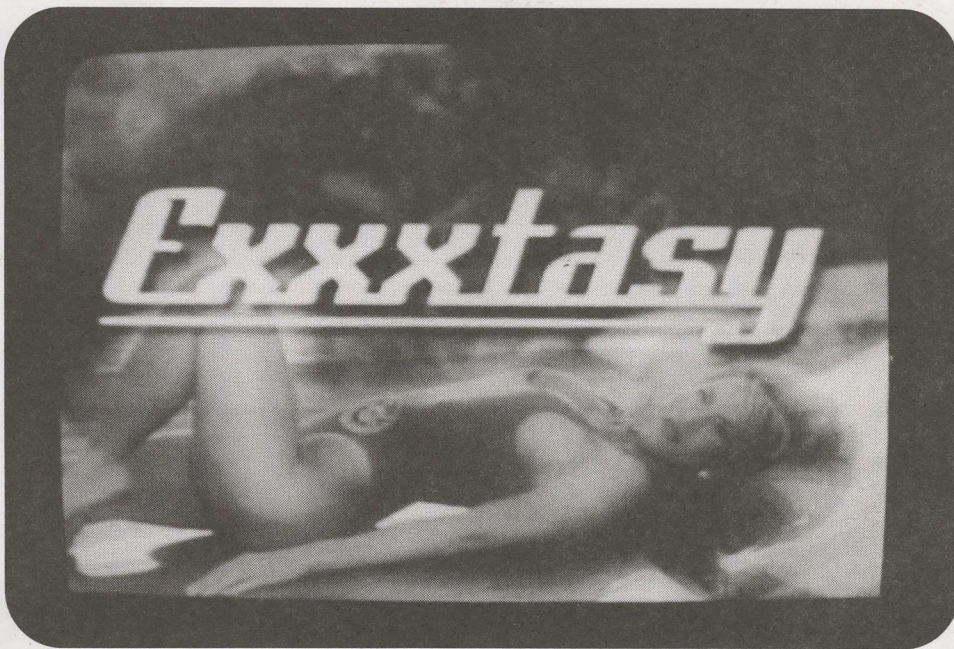

## QUESTION:

**How "Hard"  
is "Too Hard"  
for Australia  
and New Zealand???**



# Paraclipse<sup>®</sup>



CLASSIC  
SERIES

ECLIPSE  
SERIES

HYDRO  
SERIES

When quality, strength, and accuracy are your main requirements, **Paraclipse** antennas are your first choice.

Only **Paraclipse** offers such variety; four distinctly different series: the Truss-Ribbed Classic, the Courier Deliverable Eclipse, the Stretch Formed Hydro, the Commercial Patriot.

Every **Paraclipse** model sets the industry standard in its class, worldwide.

Distributed in Australia by

**SKANDIA ELECTRONICS Pty. Ltd.**

183 Burwood Rd, Hawthorn, Melbourne  
Tel 61-3-9819-2466 \* Fax 61-3-9819-4281  
Level 1, 39 Terry St, Rozelle, Sydney  
Tel 61-2-9555-2955 \* Fax 61-2-9555-2455

Distributed in New Zealand by

**BAY SATELLITE TV Ltd.**

PO Box 3311, Napier  
Tel 64-6-843-2596 Fax 64-6-843-6429

**Paraclipse<sup>®</sup>**  
HIGH PERFORMANCE ANTENNAS

Paraclipse Inc.

2271 29th Avenue East, Columbus, Nebraska USA 68601  
Telephone: (402) 563-3625 Fax: (402) 564-2109

★ **MADE IN AMERICA**



# SatFACTS MONTHLY

ISSN 1174-0779

is published 12 times each year (on or about the 15th of each month) by Far North Cablevision, Ltd.

This publication is dedicated to the premise that as we enter the 21st century, ancient 20th century notions concerning borders and boundaries no longer define a person's horizon. In the air, all around you, are microwave signals carrying messages of entertainment, information and education.

These messages are available to anyone willing to install the appropriate receiving equipment and, where applicable, pay a monthly or annual fee to receive the content of these messages in the privacy of their own home. Welcome to the 21st century - a world without borders, a world without boundaries.

## Editor/Publisher

Robert B. Cooper (ZL4AAA)  
Office Manager  
Gay V. Cooper (ZL1GG)

## Reaching SatFACTS

Tel: 64-9-406-0651

Fax: 64-9-406-1083

Mail: PO Box 330

Mangonui, Far North  
New Zealand

## Subscription Rates

Within NZ: \$50 p/y

Australia: AV-COMM Pty Ltd, PO Box

225, Balgowlah, NSW 2093

61-2-9949-7417

Elsewhere: US\$60 p/y

All copies sent via airmail fast post  
world-wide

## ERRATA

SatFACTS Copyright 1997 by Robert B. Cooper; any form of copying is a violation of our international copyrights. Advertising rate sheet available upon request.

## COOP'S COMMENT

Selecting photos for this month's Triple XXX rated report of Exxtasy was a challenging exercise. Initially, only the Australians seemed able to find the signal and we had asked several readers who had located 177E to get us some VHS video from the reception. We specifically asked that we not be sent anything erotic - actually we were after the in-between movie programme promos. Garry Cratt finally decided to shoot his own still pictures with the note, "You could get arrested for having the video tape if I sent a movie!"

Barry Ward with a 3.7m was first to

find 177E in NZ but only on an analyser. Robin Colquhoun hauled a sampling of receivers to Barry's home and together they explored the length, width (and depth) of 177E. At this point the Australians were reporting both "964" and "973" were 'hot' with programming.

Here at SF we finally got the parts together on June 20th and with the assistance of the crew from Pacific Antenna using a Patriot 3.1m we had all of the action (less 964 which had gone silent). As the photos (left) show, the SA 9223 and Nokia (2+) had no trouble loading the service. I like the symbolism in the analyser display - almost identical to the camera angles on Exxtasy!

More seriously, it is not just the films that are triple-X, but the commercials between movies are even "harder" to swallow (pardon the pun). It concerned me enough (and I have not led a sheltered life) that I sat down and wrote James Tzeng at Space TV Systems a four page fax pointing out how Australian (and New Zealand) laws could be a serious problem with the content of Exxtasy. His quick response told me Space was not only not the provider of the adult channels, but that it would probably go away "to a transponder of its own" shortly. Then, wearing my cable TV operator hat, I located Exxtasy in Canada and queried them regarding cable TV rights to carry the service (there is, after all, a market for this stuff although perhaps the market is not ready for the implicit content of Exxtasy).

By midday on June 27th 973 had joined 964; silent. I erased all of the channels from my Nokia and asked the receiver to load the transponder anew. When it did, 964 and 973 did not reappear - telling me Exxtasy had been yanked off the Space TV feed.

We haven't heard the last of adult films via satellite - but for those who stay closely tuned to industry developments, there was a ten day period in mid June 1997 few will soon forget. For the full story on how all of this happened, and why, I direct you to our report beginning on page 6. The photos? In the end, we decided to self limit to 'R' scenes.



July 15, 1997

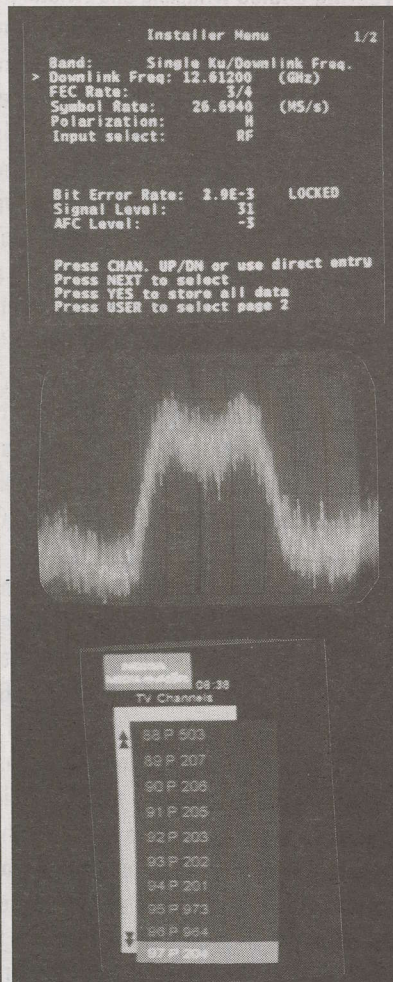

## In Volume 3 ♦ Number 35

WHAT DO YOU GET WHEN YOU MARRY  
Mandarin Chinese to Triple XXX Exxtasy? -p. 6  
DIGITAL HARDWARE UPDATE 97-6  
Includes New PAS-2 Ku Activity -p. 14

## Departments

Programmer/Programming Update -p.2; Hardware/Equipment Update -p. 4;  
SPACE Notes: SPRSCS '98 -p. 20; CABLE Connection - Cash Flow -p. 22;  
SatFACTS Orbit Watch -p. 24; MPEG-2 Tuning Parameters -p. 26;  
Digi Notes Reference Information - p. 28  
With The Observers -p. 29; At Sign-Off (The Exxtasy Affair) -p. 32

## -ON THE COVER-

In the privacy of your own home - should you be allowed total freedom of choice with no censorship of content? If no - with universal conditional access systems on the way and a totally international credit card system - how will 'authorities' police 'explicit content' that goes beyond the limits of national laws? The issue is here - now - as Exxtasy cranks up on I177E with a triple-X film channel (p. 6).



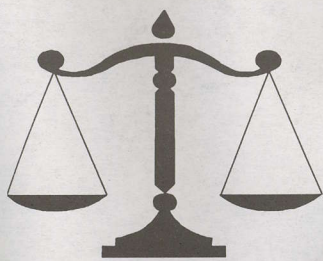

L  
E  
T  
T  
E  
R  
S

# PROGRAMMER PROGRAMMING PROMOTION

# UPDATE

JULY 15, 1997

### Don't Hack Your 9223

"Reference May SatFACTS and cover feature suggesting cooling of the SA D9223. I use this receiver on a 14.5' Paracclipse here in Tahiti on the California PowerVu service. I suggest that rather than taking a saw and ripping a hole in the rear deck of the 9223, use double sided 3M mounting tape and a small fan (as shown in your report) to mount the fan inside of the case. No new holes need be drilled, the fan blows hot interior air towards the exterior of the unit. I also elected to power the fan with 24 volts found in the 9223 power supply. And my warranty is still good!

Grant T. Waldref, Jr.

Starcom Inc., Papeete, Tahiti

**NO question - the object is to get air moving. The 9223 has modest top side vents for natural air flow (heated air rises) so this is probably a good way to reduce the receiver's heat build-up. Of interest: Photos of the new (yet to be released) Nokia 8200 S clearly reveal a fan has been added to the rear deck (see p. 30, here).**

### Something "Lost" in Translation?

"You reported Mongolian TV running very recent US made movies in English (SF#33, p. 2) with the audio significantly reduced in level and then translated over and slightly behind by Mongolian TV on As2. I have noticed the many Russian service channels available here on C as well as Ku are now doing the same thing; typically you hear only two voices (one male, one female) doing all of the 'parts' for the English speaking actors. What we need is a software filter that somehow manages to recognise the English but ignores the over dubbed non-English translations!"

Gregorio V. Hermosa, Jr.

Sultan Qaboos University, Oman

**That the Mongolians (or Russians, et al) actually contract for television rights to these very recent release movies and pay fees to the rights owners is very doubtful. If they did, the movies would not be released on FTA satellite networks months ahead of their release on western Pay TV networks. It might be more expedient to take a night course in Mongolian (or Russian)!**

### Russian 96.5E Status

"We notice the Russian signal from Gorizont at 96.5E is deteriorating considerably. Two bands of horizontal lines appear and the signal quality comes and goes constantly even though the audio can be clear. We are tracking the satellite but do not seem able to overcome this problem. Is this channel having technical difficulties; what is being done to rectify this problem?"

Brent Dunnett, Satellite Division

Colorpix, Vic, Australia

**Nothing good is going to happen to any of the existing Gorizont birds; expect the pictures to get worse and worse and then one day go away over**

(continues / page 4)

**Naked, thrusting bodies** wriggling and twisting, moaning and exclaiming phrases we won't publish here are leaping from the screen in a digital bouquet beaming down from Intelsat 702 at 177E. Geoff Dargie at Nationwide Antennas (Bowen Hills, QLD) was apparently the first to "come across" the new (adult movie) service. Garry Cratt, in describing it one day later observed - "Well, you know how they milk cows? What I see on the screen is just like that except there aren't any cows." Look for the programmer (Exxtasy) to do a deal with a single firm to represent them in Australia/New Zealand - provided there is a way around the Australian "Hard R" ratings limit; this is a triple "X" service. Details on page 6.

**Hard core off** - for now. As we go to press, adult channels (964 and 973) within Space TV Systems bouquet are not transmitting; a "temporary situation" according to Fred Pantalone of Exxtasy. If you tune to 177E, load your Nokia/ Hyundai/ PowerVu to the transponder and it shows two non-operating programme channels (973, 964) sandwiched between 201 and 204, those are the ones. If there is no video/audio there, it is because they are not transmitting programming, not because of any clever CA routine. They worry that without CA, the Triple "X" movies could offend some casual tuners-in.

**How much Mandarin is enough?** Granted there are more than a billion Chinese at home and abroad. Now CCTV on PAS-2 has expanded their bouquet to 6 which adds to TCS's 1 which adds to CTN's 4 which adds to SPACE TV's 6 which adds to the 12 (digital) services on As2 which adds to the 6 STAR Mandarin services on As1, As2, C2 et al. Uncle at 35? More are planned shortly.

**Big bucks.** SKY Channel (horse) racing out of Australia is expanding across the middle east on the strength of its new AsiaSat 2 digital platform with terminals going in at Oman, Korea, even Bulgaria at the north-western tip of As2 coverage. An appropriate receiver says there is not one but 3 programme channels in the bouquet; SKY won't explain who the other two are except to note, "They are not us and we had to reduce our power by 3 dB to accommodate these guys." Have a horse racing customer in your patch? Fee is 10,000 in US dollars per year for a DTH licence <sup>45</sup> equipment extra. Still interested? Bob Pankhurst in Australia at tel 61-2-9541-0888.

**Antenna 2**, Greek national terrestrial service, is latest European service to arrive in Pacific; check California PowerVu (3901Hz, see p. 27) for presently FTA NTSC feed typically 18 hours daily. Will it stay FTA? No word yet, but California PowerVu did undergo major change to fit it in so it is likely to remain on this bouquet.

**DirecPC**, the Hughes North American 400 kbps satellite to home downloading system that allows Internet surfing to increase by a factor of 14 times or more - is headed for Australia very soon via PAS-2. Several Australian firms are involved - watch for announcements involving Telstra in particular in next 30 days. New Zealand? Technically, same PAS-2 Ku beam hits NZ as well, but Telstra's initial business plan is for Australia only.

**SCOLA Worldwide**, the free to air educators channel, is coming to the Pacific/Asia. Possible bird is Gorizont at 96.5E (not a fantastic choice). SCOLA collects news feeds from more than 40 countries daily, makes up composite 24 hour TV broadcast day, and redistributes to DTH, cable, SMATV. Contact is Lee Lubbers, S.J., fax (+ +)1-712-566-2502.

**Imparja** (and Australian ABC National) now on PAS-2 (Ku) could be fairly long term; mixed signals from participants say "short term test" and "long term." Initial tests FTA, went CA PowerVu July 5. "Test" is operative word; expect changes.



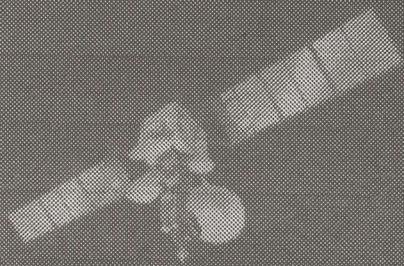

HYUNDAI



Connect to the World...

# HYUNDAI Digital DBS Set-Top Box

HSS-100C

MPEG-2 (MP @ ML) & DVB compliance

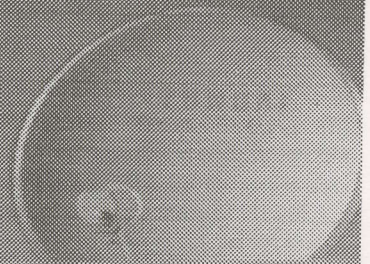

## PROVEN PERFORMANCE

**Power Vu**  
**DVB Compliance**  
**FTA**



Distributor - Australia & New Zealand

**Skandia**

Skandia Electronics Pty Ltd

Victoria: 183 Burwood Road Hawthorn 3122, Australia  
Telephone: (613) 9819 2466 Fax: (613) 9819 4281

NSW: Level 1, 39 Terry Street, Rozelle 2039, Australia  
Telephone: (612) 9555 2955 Fax: (612) 9555 2455

- QPSK demodulation
- CD Audio quality (MPEG-1 Layer 1 & 2)
- Access up to 500 virtual channels
- Supports the aspect ratio both 4:3 and 16:9
- Easy-to-navigate electronic program guide

Hyundai Electronics America, Inc. 10000 Wilshire Blvd, Los Angeles, CA 90024



the next few years. The Russians are out of (satellite) money, and while they may have at one time had the largest fleet of satellites in orbit, they are no longer able to replace the short-life-span inclined orbit by design Gorizonts as often as in the past. Most Gorizonts will be gone by 2002 (useless) and a few - about 1 in 4 - will be replaced with next generation C + Ku high power non-inclined orbit birds. The Gorizonts at 53, 90 and 103E will be replaced with newer birds by 2001; as for the balance of the Gorizont locations, over time these spots will be given up to non-Russian birds. If you have customers using 96.5E, it will grow worse and then quit.

#### Straight Arrow

"Reference pages 4 and 20 of SF #34. AUSTAR (previously CETV) is a fully owned subsidiary of United International Holdings Asia Pacific, one of two exclusive regional franchisees of Galaxy. AUSTAR currently uses the existing satellite infrastructure of the Galaxy Network (Optus B3, T10 and 11 HP beam) to provide DTH services to regional Australia and within the AUSTAR franchise boundaries. AUSTAR does not use a national beam off any satellite. The service mentioned p. 4 June (12.550 GHz, etc.) was actually a test by the satellite operator (Optus) not by AUSTAR. The company is in final stages of constructing a large HFC network in the greater Darwin area and does not distribute via DTH in that region. However, people who live outside of the HFC area but still within the AUSTAR franchise region are being offered a digital satellite IRD (which remains the property of AUSTAR) provided the customer provides their own satellite dish; as reported p. 20 in June. This service is available ONLY to people who live inside of the franchise boundaries and within areas designated by AUSTAR as remote."

Adrian Potter, Sydney Engineering  
AUSTAR Entertainment Pty Ltd.

Curious that those who saw the testing on 12.550 report their receiver IDs said "AUSTAR." We must assume Optus had to "call it something" and accidentally picked those 6 letters for their tests. Regardless of whom the tests are for, the service was certainly there as reported (p. 4, June). It will be interesting to see how many consumers tumble to the fact that by giving a physical address within the "franchise boundary" of Austar Darwin, they can access this package of services on subscription.

#### Software Upgrades

"Re June SF report on Nokia 2.233 software. Can you tell us how to have our earlier version software updated rather than throwing away a perfectly good receiver? I am not a software person but if it is just a matter of software, could not the developers of the 2.233 software - for a fee - provide a way to reload the new software?"

D. Morris, Bangkok, Thailand

Nokia has promoted the 9500 S family as "software upgradeable" from the outset. We are aware that some non-Nokia sources in Germany are offering such a service but the factory warns us to avoid such services under threat of losing warranty backup. Bottom line - if Nokia - the factory - does not follow up, people will go to other sources. Are you listening, Nokia???

## HARDWARE EQUIPMENT PARTS

## UPDATE

JULY 15, 1997

As we went to press with SF#34, the last "correction" we made was to change from July to August the expected release date for a new version of the Nokia which is claimed will have twin menus: One for PowerVu services, one for FTA PAL MPEG. Reason for change is now clearer: Nokia has been negotiating with Scientific Atlanta (since April) seeking to be "licensed" by SA to incorporate PowerVu processing in the Nokia receivers. Why would they need an "SA license?" They believe - and SA apparently agrees - the PowerVu "DVB Compliant" software is proprietary to SA. And any firm building receivers capable of accessing PowerVu without a contract with SA to do so is in violation of SA patents and perhaps software copyrights. If SA offers Nokia a licence to build PowerVu into future Nokia IRDs - and Nokia does so - that should end for all time the SA myth that their PowerVu is "DVB Compliant" like everyone else. If it was, nobody would require an SA licence to access the system!

**Nokia NTSC Glitch.** European expert says, "the hardware side connection between C19100 (C-Cube MPEG-2 decoder chip) and the SAA 7124 (Philips video encoder chip) is configured for only single sync standard use; not suitable for automatic 50/60Hz switching with the (current) revision 3 mainboard." Bottom line? Hardware, not software is NTSC limitation and software upgrade may never happen.

"My Hyundai requires a stronger signal than either the SK888 or Nokia Mediamaster" reports Steffen Holz in New Caledonia. With 2.5m dish, EBB service is solid in Noumea as are various PAS-2 services. Substitute Hyundai HSS-100C, and no reception. Upgrade to 3.6m dish, and Hyundai now works. SF has just the reverse report from others; the Hyundai tunes-in signals the Nokia won't touch. Bottom line? It may be "how" you are using a receiver more than the engineering characteristics of a receiver.

**STAR Asia** on AsiaSat 2 3700 (transponder 2A) and 3900 (7A) where encrypted for conditional access is using the same CA/IRD/smart card as is being used for Indovision on Palapa C2. The basic receiver for all is the PACE DVS-211 (GP). An Indovision subscription gets you the right IRD/CA and card but not the correct authorisation stream approval for use on AsiaSat 2A or 7A. The primary users of the 2A and 7A encrypted services are Taiwan cable TV systems and where the 7A services are in NTSC, the IRD and smart card are equipped with "Star version software" to allow the receiver to process the non-PAL format signal. If you think you must have 2A or 7A services, move to Taiwan and start-up a cable TV company!

"**Inherent software problem**" is how one engineer describes field problems with Pace DVS-211 series receiver now in use by Indovision and Sky (Australia horse racing). "The software places a blank vertical bar down the edge of the screen" is the report. Attempts have been made at Sky (horse racing) to correct the problem by modifying the software parameters of the transmitted signal - it may not work. A second source advises, "The IRD software places active video too early in relation to the horizontal sync which appears as a left shift of the image on the screen. It can be fixed by software in the IRD and will be part of the next software download. There is not a need to recall receivers and there is nothing that can be done to the transmission to correct it."

**Free 'd-boxes'?** Germany's Kirch Group, having attracted only 30,000 subscribers to its digital pay TV platform after projecting 200,000, has resorted to the ultimate trickery: Subscribe to their digital package and they will gift you with a d-box (Nokia Mediamaster 9500 S). Now - all you need is a cousin in Germany to sign up, collect his d-box, cancel his subscription and ship you the Nokia!



# ADL<sup>®</sup>

BECAUSE PERFORMANCE IS ALWAYS YOUR FIRST PRIORITY

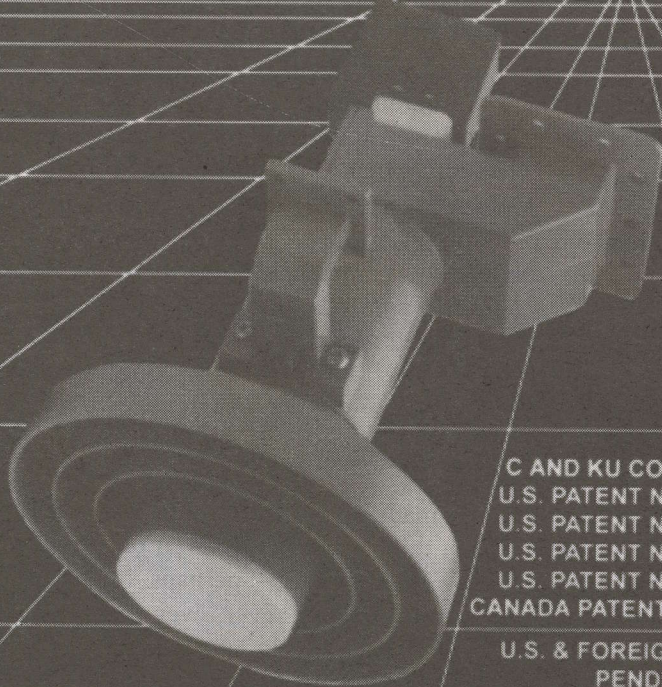

**RP3-CKU/ International  
Adjustable Scalar Ring Feed  
with Extended C Band**

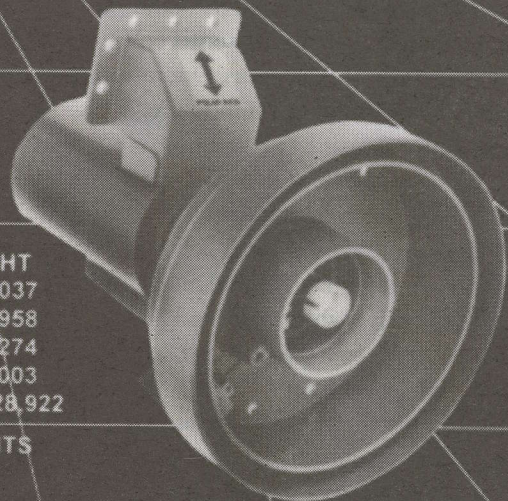

**RPI-CKU Feed**

C AND KU CO-BORSIGHT  
U.S. PATENT NO. 4,903,037  
U.S. PATENT NO. 5,066,958  
U.S. PATENT NO. 5,107,274  
U.S. PATENT NO. 5,255,003  
CANADA PATENT NO. 1,328,922

U.S. & FOREIGN PATENTS  
PENDING

## ADL HYBRID MODING CIRCULAR POLARIZED INTELSAT FEEDS WITH EXCLUSIVE T.I. REJECTION



**RP1-CP400**

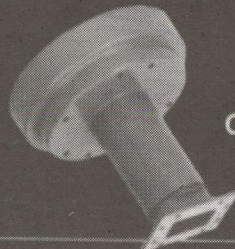

**CP-300**



**CPOR-100**

- C BAND LINEAR & CIRCULAR • C/KU LINEAR & CIRCULAR • KU 12 GHz FEEDS
- INTELSAT 4 GHz CIRCULAR • ARABSAT S BAND FEEDS

OPTIONAL: CO-BORSIGHT S BAND

2216 AGATE COURT, UNIT B, SIMI VALLEY, CALIFORNIA 93065 • (805) 526-5249 • FAX (805) 584-0634



## TWO CHANNELS OF ADULT FLICKS "POP UP" ON 177E

It was an excited Geoff Dargie who telephoned SF to report, "There are two channels of blue movies now free to air on 177E!" Dargie's firm, Nationwide Antennas near Brisbane, had received an unusual telephone request from a gentleman with an Asian accent.

"Do you have a spectrum analyser?" the voice asked. Dargie confirmed they did.

"Do you have a 1.2 metre or larger Ku band dish that can be turned to 177E?" Again, affirmative.

"I will be in to see you, shortly" said the voice.

And so James Tzeng, Executive Vice President and General Manager of Overseas Operations for Space TV Systems, Inc. (Taiwan) announced his presence in Australia.

"As we swung the 2.4m dish east," relates Dargie, "and watched the transponders from B3 fade and then B1 and then silence until PAS-2, I could tell the guy was only faintly interested in the analyser screen. As we approached 177E, which to my knowledge had no Ku band operational, four or five carriers came up out of the noise and one was clearly MPEG - big, tall and fat. Mr. Tzeng instantly came alive, pointed at the fat MPEG carrier on the screen, and announced - 'There - that is us!'."

"I think he was satisfied just to see the carrier on the analyser," Geoff notes. "I wanted to throw a receiver at it and he told me that it would require a Thomson IRD. While he was protesting, we were scrambling to hook-up a Nokia (9500 S, version 2+). While Mr.

Tzeng told us "Not to bother" we had the Nokia already in a search, identify and memorise mode. I watched it count off programme channels - 11 or so in all at the time. I thought 'Wow - this is really loaded!'"

"We started off with the first one to load and it was a blank screen (1). So were the next two. Then we ran into some Mandarin programming - a newscast, a kids show, a lifestyle show. I was about to push the button for the next up channel when Tzeng cautioned me. He obviously knew what was next - I did not. As I recall, he said something like -

"Now, the next two channels are not ours - they are a part of our bouquet, but we do not operate them."

"The screen flicked and silence fell across the room. Up to this point my staff had been only modestly interested in what appeared to be yet another long list of Chinese TV channels. Impressive, but hardly interesting to us white guys.

"The TV audio made up for the total lack of sound in the room - I don't think anyone was even breathing. On the screen, two naked bodies - perhaps it was three actually - doing things I had never, ever seen on a TV screen before. Anyplace."

Blue movies had arrived in the Pacific. It was 11AM Australian Eastern on Tuesday June 17th.

Who Are These Guys - Anyway???

James Tzeng left Nationwide and rushed to an airport only minutes after the TV screen took on an entire new reason for being. He answered almost no questions and

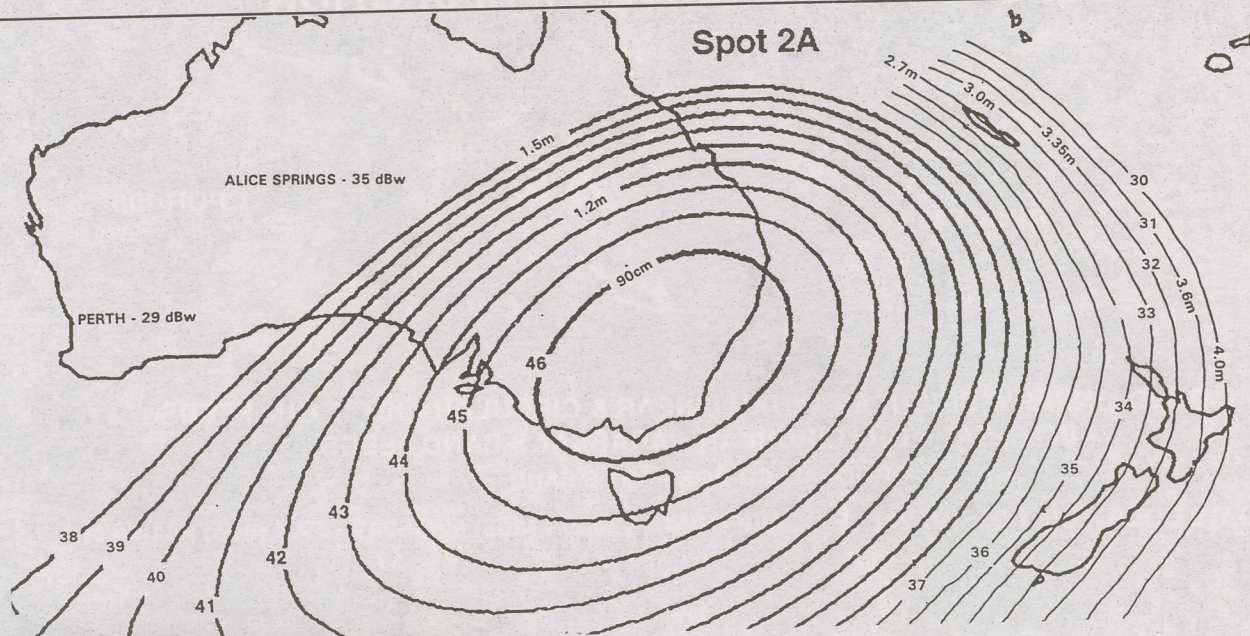



### Dish Size vs. Footprint for 177E

| dBw eirp | Dish Size<br>1.8 dB LNB | Dish Size<br>0.7 dB LNB | 1.8 dB<br>Dish Gain |
|----------|-------------------------|-------------------------|---------------------|
| 46 dBw   | .91m                    | .75m                    | 38.9 dB             |
| 42 dBw   | 1.2m                    | 1.0m                    | 41.4 dB             |
| 38 dBw   | 1.8m                    | 1.4m                    | 45.0 dB             |
| 37 dBw   | 1.9m                    | 1.6m                    | 46.0 dB             |
| 36 dBw   | 2.3m                    | 2.0m                    | 47.3 dB             |
| 35 dBw   | 2.7m                    | 2.3m                    | 48.5 dB             |
| 34 dBw   | 2.9m                    | 2.5m                    | 49.0 dB             |
| 33 dBw   | 3.1m                    | 2.7m                    | 49.5 dB             |
| 32 dBw   | 3.65m                   | 3.2m                    | 50.9 dB             |
| 31 dBw   | 3.9m                    | 3.6m                    | 51.6 dB             |
| 30 dBw   | 4.7m                    | 4.2m                    | 53.2dB              |
| 29 dBw   | 4.87m                   | 4.3m                    | 53.5 dB             |

Note: Table above allows only 1-1.5dB of margin above 36 MHz bandwidth threshold in MPEG-2; rain fade margin must be added on top for protection from rain outages.

in the best oriental tradition left a mystery behind. It would be nearly a week before some hard answers began to surface.

Space TV Systems, Inc. is a Taiwan based firm that claims to have US\$65,000,000 in the bank to fund their start-up pay TV operation. They have big plans to fit their "deep pockets."

They say they will provide 8 video channels and 10 audio channels to DTH subscribers in Australia, using a (Ku) 46 dBw boresight centre of pattern signal from Intelsat 702 located at 177E (see pattern to left). Tzeng told SatFACTS he believes the signal level will support "a 75cm antenna in Brisbane and Sydney". Initial tests suggest one of two conclusions:

1) Space has been overly optimistic with their engineering calculations - we find a 1.2m antenna has occasional freeze framing (loss of MPEG threshold) in Brisbane even with clear skies;

### LNB Noise: Degrees Kelvin vs. Noise Figure

| Degrees K | Noise Figure | Degrees K | Noise Figure |
|-----------|--------------|-----------|--------------|
| 159K      | 1.9 dB       | 92K       | 1.2 dB       |
| 149K      | 1.8 dB       | 84K       | 1.1 dB       |
| 139K      | 1.7 dB       | 75K       | 1.0 dB       |
| 129K      | 1.6 dB       | 67K       | 0.9 dB       |
| 120K      | 1.5 dB       | 59K       | 0.8 dB       |
| 110K      | 1.4 dB       | 51K       | 0.7 dB       |
| 101K      | 1.3 dB       | 43K       | 0.6 dB       |

2) Or, Intelsat has misled Space and they are not delivering 46 dBw at boresight as promised. We'll return to this subject.

The 8 (Space) TV channels do not include a Blue Movie channel service; they are an additional 'extra.' As Geoff Dargie explains, "Sure the Chinese package might sell a few hundred dish systems in Queensland over a year - but my - oh my ... when you also add the Blue Movie channel(s), well! Now there is something to get excited about. We could sell thousands of these - if the price was right!"

So what about the Blue Movie services? First of all, we'll give them a 'name.' The primary channel is called Exxtasy. This is a US adult channel service (also available in Europe) and on a scale of porn that starts with fully clothed adults making out at '1' (a Doris Day movie) and ends at 10 with human beings having sexual relations with dumb animals - Exxtasy is an 8.5. No part of the human anatomy escapes the camera. You've heard of mounting cameras on motorcycles or inside of race cars or even on horses, to catch unusual 'action shots'? Exxtasy has discovered ways of burying cameras in places only a skilled gynaecologist has previously ventured. We'll return to that subject, as well.

Exxtasy is "not related to Space TV. Space is not going to offer the Exxtasy service to Space subscribers," says James Tzeng. So what is Exxtasy doing inside of the Space TV bouquet? Tzeng, again.

"Our (Space) transmission service operator, Oriental Telemedia Corp, subleases our extra bandwidth to Exxtasy (for a short term contract). It is entirely likely

### -SPACE TV Systems Tuning and Operational Parameters from 177E-

(1) Intelsat (I)702 at 177E; (2) Ku band Spot "2A"; (3) 12.612 GHz; (4) (With 11.300 GHz LNB local oscillator) IF 1312; (5) Horizontal polarisation; (6) Bandwidth - up to 72 MHz; (7) Msym rate 26.694; (8) FEC 3/4; (9) Information rate - 36.9 Mbps (10) Video format: NTSC; (11) Number of TV channels: 7 at presstime, additional promised; (12) Access: Reported to be FTA until 1 September, conditional access (subscription) thereafter; (13) Access system: Viaccess, developed by French Telecom, licensed to Thomson, Samsung (model SRT 5200V) and apparently Acer Computers; (14) Receivers that work with present FTA tests : (a) Nokia 2X (with NTSC 'glitch'), (b) Hyundai HSS-100C, (c) SA D9223 [with less than perfect video]; (15) Contacts for service: Chinese (Korean) service channels - James Tzeng in Taiwan at tel (+ +)886-2999-2939 and fax (+ +) 886-2999-2989; Exxtasy film channels - Fred Pantalone (Ottawa, Ontario, Canada) , tel +-1-613-228-6557, fax +-1-613-228-7717



**-Intelsat 700 Series Ku-Band Capabilities-**  
 Intelsat 702 at 177E has the following Ku technical capabilities:

Under operator control, 3 spot beams can be directed to virtually any portion of the line of sight coverage region. Spot 1 is 45.4 dBw boresight, Spot 2 is 44.5 dBw while Spot 3 is 46 dBw. These numbers are nominal and in operation may be as much as 2 dB higher. There are 10 Ku-band transponders, 5 of which are 35 watt, 5 at 50 watt. Six of the transponders are 72 MHz wide, 4 are 112 MHz. Up to 5 transponders can be connected to a single spot beam. Spot 1 is vertical polarity, Spot 2 is horizontal and 3 may be either V or H depending upon whether it is "attached" to 1 or 2. The downlink frequency bands on board are 10.95-11.2 (GHz), 11.45-11.70, 11.70-11.95 and 12.50-12.75. Project Amiorangi (SF June, p. 2) used 11.514 GHz boresighted on New Zealand while SPACE TV Systems is using 12.612 GHz boresighted on Australia. I701, presently at 174E but heading to 180E by September, has the same technical capacity. In theory, only 11.45-11.70 and 12.5 - 12.75 will be used in the Pacific.

*the adult service will move to another transponder when we begin to market our own service. At the moment we are free to air, and they are using our spare bouquet bandwidth."*

So, if Exxtasy is not part of the Space bouquet, and Space will not be offering it within their own marketing programme, who then will be handling Exxtasy? Should the Geoff Dargies of the world even be talking with Space if all they are really interested in selling is the Exxtasy portion?

Back to I702 at 177E for a moment. This satellite has some unusual capabilities. As explained above, there are 3 separate Ku band spot beams on board. The Space transponder is 72 MHz wide (when fully loaded - it is not at press-time). The uplink site is in Brewster, Washington (USA). To get the Taiwan based MPEG-2 DVB services to Brewster, Oriental Telemedia Corp.

has leased C-band space on I511 at 180E (yes - that's the inclined orbit bird scheduled to changeout with I701 in September). The C-band feeds from Taiwan are downlinked at Brewster and mixed there with the Exxtasy feeds which originate in North America (which explains why when you are watching Exxtasy you see US "eastern time zone" promotions for upcoming features). Now the re-multiplexed MPEG bouquet is sent back to 1702 using a C-band uplink at Brewster. Inside of I702, the bouquet is cross strapped to Ku band and fed into not one but two separate spot beams. One goes north towards Asia and the other goes west towards Australia (spot 2A); see diagram below.

Exxtasy maintains a Canadian office (XTC-Com; see bottom, p. 7, here). If James Tzeng is playing his Space TV Systems business plan close to the vest, XTC-Com has theirs hidden so far out of sight that even a gynaecologist with a "VagiCam" can't find it. And we'll return to that subject, as well.

Space TV Systems Alone

After James Tzeng jumped onto an aeroplane and returned to Taiwan from Geoff Dargie's office in Brisbane, nothing was heard from the firm for nearly a week. Which is totally understandable - Dargie's many faxes to Tzeng were all about something (Exxtasy) which Tzeng was not even offering for sale. Tzeng had told Dargie that they would be using a Thomson IRD and that he had brought into Australia "3 or 4" of the IRDs which had been left behind (alas, not one at Nationwide). It would turn out that this was a part of Tzeng's plan to utilise Chinese émigrés to Australia as his marketing campaign to promote the service there.

Three agents have been appointed by Space as we go to press; you may be disappointed with the 'quality' of the representation (2).

On June 28th, Space held a press conference in Washington, DC (an unusual choice, we think) to announce the formal launching of a 40 channel Space TV North American DTH service (August 1 start), expanding to 80 channels in 1998. A Space TV digital teleport is under construction in Lancaster, California.

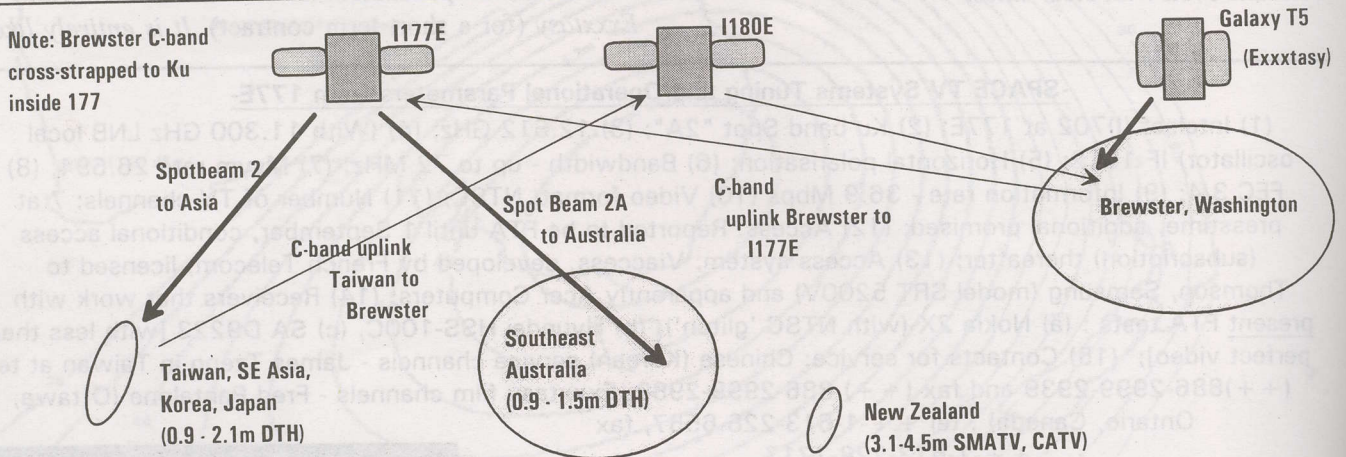



# The Nokia Mediama<sup>ster</sup> DVB 9500 S.

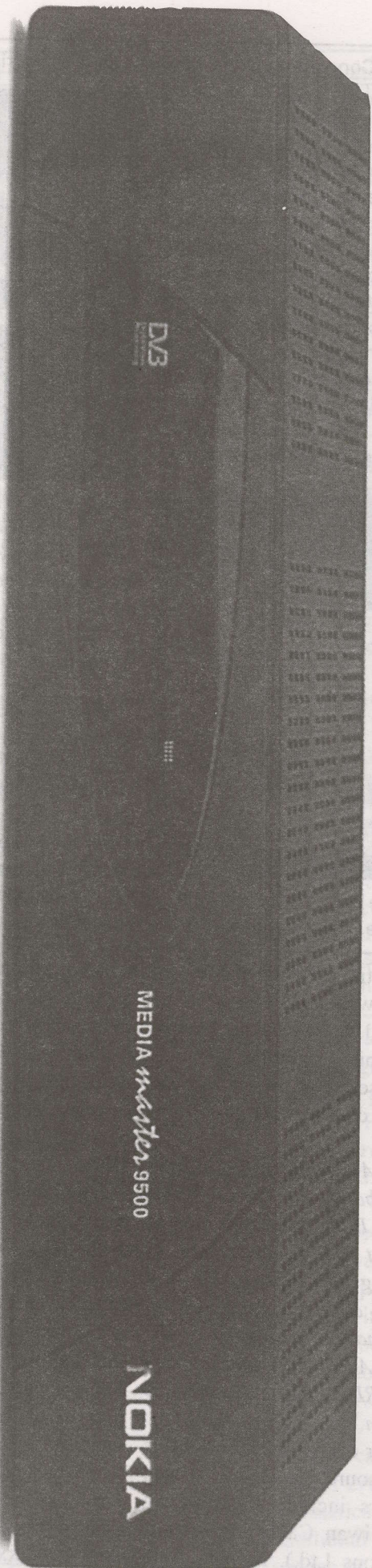

Brings the power of multimedia to your TV.

**OPAC** Pty. Ltd. **TEL 61-2-9584 1233 • FAX 61-2-9584 1452**

• 99-105 BOUNDARY ROAD, PEAKHURST NSW 2210 AUSTRALIA • Email [opac@internet-australia.com](mailto:opac@internet-australia.com)



-A Few Words Concerning 'Blue Movies' as a Subscription Pay TV Service-

The average "blue movie" costs US\$17,000 to create.

That gives you some idea about the quality of the product. There are no scripts, and for those occasional lines of dialogue that an actor or actress is required to utter, the words are not memorable. In most situations, they could recite the '10 Commandments' and nobody watching would even notice. There are only so many creative things you can do with human body parts, ping pong balls, old tennis shoes and those plastic things you find in fruit bowls - before becoming repetitive. Exxtasy avoids animals and small children but very little else.

Four and five star hotels typically offer "adult films" in rooms for between \$12 and \$25. Rental stores routinely charge \$5 to 7 for adult flicks. Individual

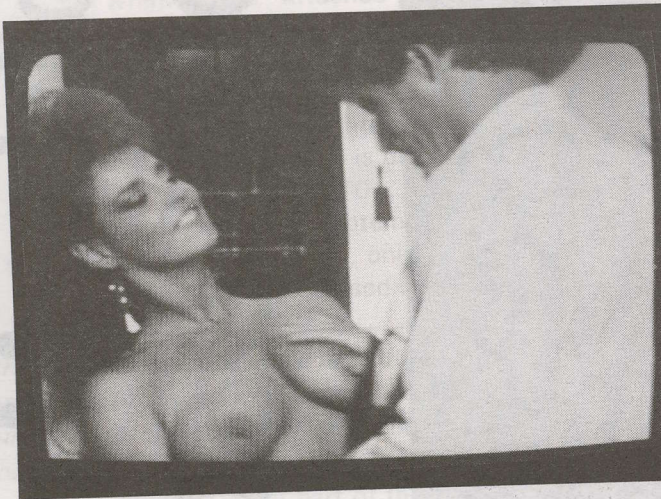

titles are unimportant - scripts don't exist and after four or five films you have seen every camera angle and heard every moan and utterance you will ever encounter in additional films. In other words, after the initial shock wears off - they are boring. One 24 hour service with nothing but "XXX" films amounts to 720 hours per month - after the first 8 to 10, there is nothing new left to see.

Why should you care? Because if you sell a dish system on the strength of "XXX" films, we suggest you get your money - **all of your money** - before the customer has finished the second movie. Thirty day billing could be very dangerous. In fact, if a customer still raves about their "XXX" service 30 days after they get it, that might be a clue that you should never

leave your small children alone with that customer. Adult movies may become a part of your DTH business scene - your choice of course - but watch out if the lady of the house offers to pay you with "trade."

The 8 video channel service initially being offered on I177E on spot beam 2 into Taiwan and Asia is to be expanded to a 160 channel (120 video, 40 audio) programming package when Filipino Mabuhay launches later this year. There they will use the powerful 54 dBw boresight centre signal to serve dishes down to 45 cm size.

About Australia, Tzeng says, "*Australia's DTH market for us is only a small game in a backyard. The big game for us is in the front yard (Asia). In Asia we are going to offer free set top IRDs to the first 50,000 subscribers. At one point we considered offering free IRDs to the first 20,000 subscribers in Australia - and we may still do so. However, we would prefer to have the support of the satellite DTH dealers in the Australian market and worry that if we give away the IRDs that the dealers will not actively support our program.*"

With USD \$65 million in their deep pockets, where is the backing originating? One source is Taiwan based Acer Computers (other backers include Hsiung-Feng Information Group, Central Taiwan Cable Associates, and Porli Media Communications Ltd.). In fact, Acer

will be the primary supplier of conditional access IRDs for the service by the end of the year - the Thomson units initially available will be a second source once the Mabuhay satellite portion is operational. The Thomson units are pegged at US\$450 each when purchased through Space's California offices (3). By the way, their conditional access system is something called "Viaccess" which was developed by French Telecom. Independently, we learned Viaccess has been licensed to one French firm, one Taiwanese firm. SF has also been told, "The first receivers equipped with the Viaccess conditional access system are not expected before October of this year." With Viaccess, the receiver does not have a conditional access module (i.e., CAM); rather the conditional access is handled by a chip that is an integral part of the basic receiver. James Tzeng agrees the initial Australian marketing programme may not work as they hope and he says they are prepared to "*offer our subscribers set-top boxes free of charge and pay cash back to early subscribers*" if the initial plan fails to produce results. See "The Offer" on page 11.

**And The Exxtasy Group?**

Pardon us for being sceptical of what is really happening here, but we have our reasons. Exxtasy is a

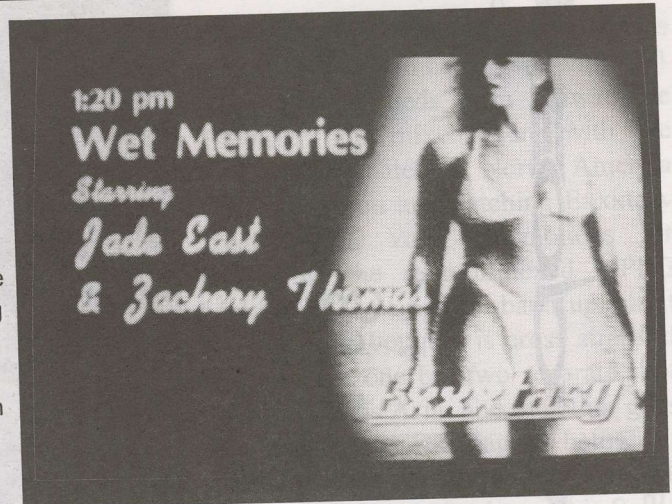



---

#### -The Space Systems TV Dealer Offer-

Initially Space was suggesting that to become a distributor, a firm would pay US\$100,000 as a 'bond' against the sale of 1,000 IRDs within 24 months. They had no takers. Subsequently (June 22)

Space modified their offer so that you may order IRDs in lots of 50 (US\$450 each) by paying for the IRDs and paying for two years of programming for each IRD at US\$55 per month (\$1,320) - US\$1,770 total. With 50 IRDs + programming that comes to US\$88,500 to be a distributor. With US\$1,770 invested as your cost (plus freight and customs on the US\$450 receiver) in each system, you must add a dish, LNBF, cables, installation. On the basis of A\$1 = US\$0.82, you will have at least A\$2,700 cost in the system (+ 2 year programming). What could you expect to sell it for in the marketplace? At 30% mark-up, A\$3,510. Is there a market for 7 Chinese TV channels (+ 10 audio channels) at this price in your region?

And if they did decide to give away the IRD but leave everything else as stated? The retail price would drop to approximately A\$2,865.

---

major supplier of at home adult video entertainment. On July 1 they expanded their operation to include 3 separate 'XXX' rated film channels on a new North American satellite. We had to go to North America to get our answers.

Fred Pantalone is Vice President of Operations for XTC-COM, the Canadian based company supplying Exxxtasy. We contacted him as a cable operator requesting information on being affiliated with his service for cable carriage. His response was:

*"We have not begun broadcasting to New Zealand and Australia as of yet. We are however affiliated with a Taiwanese company that is now broadcasting our Exxxtasy Channel into Hong Kong, eastern China, Taiwan, Japan and Korea. We have retained marketing rights in certain countries. The next phase is likely to be Australia, but by the look of the footprint it doesn't appear that New Zealand will be included."*

**Surprise!** Yes - you have begun "broadcasting to New Zealand and Australia!"

At one point in our discussion with Tzeng, before he had clarified that Space TV "has no relations with the Exxxtasy Channels," he volunteered his view of what Exxxtasy was actually doing on the Asian beam of I177E.

*"My understanding is that the adult service is actually to provide its signal to the US military camp's SMATV systems in Japan and Korea. Australia will be a secondary market. We are not going to offer this service to our subscribers." (4)*

SF had pointed out to James Tzeng that we had sought legal advice concerning the explicit content of the Exxxtasy programming we had seen being tested. It was the opinion of our legal source that the content of the

---

#### -Space TV Systems 'Basic Channel' Package-

Although the precise programming line-up may change over the coming months, here are the now operating (and planned) channels as of early July:

- (1) Taiwan Television (terrestrial VHF TV, Taiwan)
- (2) China Television (terrestrial VHF TV, Taiwan)
- (3) China TV Systems (terrestrial VHF TV)
- (4) Formosa Television (terrestrial VHF TV)
- (5) Formosa News Channel (Chinese, Taiwanese)
- (6) Kuo-Bao Channel (music, variety)
- (7) HK Channel (Cantonese channel from Wharf Cable, Hong Kong starting mid-August)

This "Basic Package" is US\$55 per month, payable for 24 months in advance at US\$1,320.

---

On October 1, Space plans to offer 4 additional Asian channels. Each of these channels will cost US\$10 per month, payable for 2 years in advance at US\$240. Customers may add any of these channels to their "Basic" package (above), or take any of the following channels alone or as a combination. When two of the following are ordered, the cost to the consumer will go down to US\$216 per channel for 2 years (save 10%); three of the following is US\$192 per channel for 2 years (save 20%):

- (a) NHK Asia (Japan)
- (b) KBS Asia (Korea)
- (c) Vietnam IV
- (d) Thaiwave (Thailand)

Thus a system purchased that only delivered (for example) KBS (Korea) would cost US\$450 for the IRD, US\$240 for two years programming, the cost of a dish, LNBF, cabling, installation and freight + taxes - approximate dealer cost of A\$1475. With a 30% mark-up, A\$1,918 installed (where a 90 cm dish could be used).

---

films shown could violate Australian (and probably New Zealand as well) regulations governing the screening of "adult materials" on pay TV services. In fact, in an early exchange with Fred Pantalone, he had offered:

*"Our channels are all XXX rated and perhaps a bit heavy for your needs."*

That there may well be legal cases to settle these questions is accepted. Our concern - that a dealer or distributor of hardware might somehow be implicated in such suits as a "supplier" of the service and forced to defend his business in court.

Technically, we believe that once the bouquet leaves Brewster, Washington on C-band and is headed back to I177E with the Taiwan original programming plus the US added Exxxtasy programming, there is no way the Exxxtasy material can be selectively removed from the (Australian) Spot 2A beam. If Exxxtasy is included for Asia, it is automatically included for 2A as well.

If, by conditional access, they control the use of the Exxxtasy service so that nobody can gain access to it



through Spot beam 2A, no legal problems will follow. It is there - it is not available. End of story. On the other hand, the longer it stays available on 2A and in a free to air format (or as an automatic 'bonus' to the Space channels in a CA format), the more likely it will attract the attention of a major media story and end up splashed all across Australia (and New Zealand) on the front page of newspapers. We suggested to James Tzeng, "This is not the kind of publicity you want for your new service."

Now - if you are an Asian reader of SatFACTS, none of these "cautions" need necessarily apply. Exxxtasy believes "the Asian market for adult films will probably demand far more action than our present triple-X provides"; a "problem" they say they will address when interest in Asia builds for their service. SatFACT's advice is very simple - your local law and your local market will determine acceptance, rejection or scorn for what Exxxtasy has to sell. If you fall within the 46 - 42 dBw footprints shown (right), the first step is to see if your Hyundai or other receiver will produce pictures and sound. If it works - then chase the sources given here.

#### Early Days

James Tzeng says, "The testing phase on I177E is over." We don't think so. On a day to day basis as we put this issue of SF to bed, there are serious engineering adjustments being made to the levels and channel assignments. This is a very complicated system created to carry Taiwan origin programming all the way back to the United States, and then resent to Intelsat from the USA. Why do they do this? Because the Space (Chinese) bouquet is scheduled for US distribution starting August 1 and I180 is how they get the bouquet into the USA for relinking via domestic satellites.

Tzeng early in June believed the service would go to conditional access "by September 1st." A June 22nd letter to potential distributors re-affixed the CA date as July 15th. In a discussion with him on June 24, he told SF, "The adult service will move to another transponder when we start to encrypt our signal in July. At this moment we don't know whether the adult service will use the same CA system as ours."

For an update as we go to press, check page 2 of this issue. To quote Leon Senior at Skandia, "It's all happening - now!"

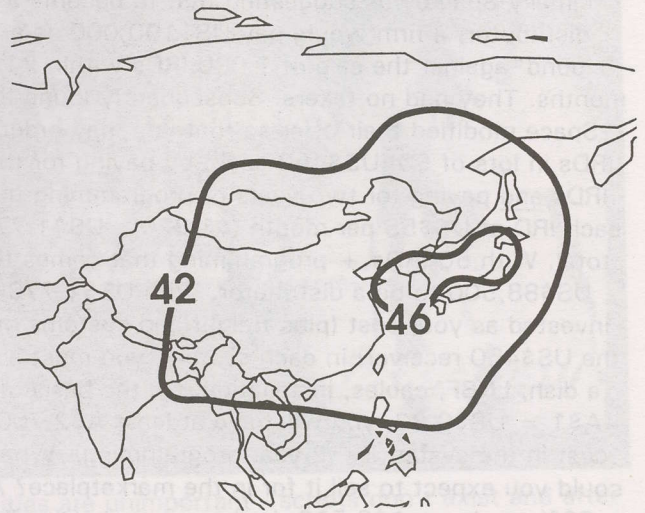

BEST approximation of I177E Spot 2 service into SE Asia for Space TV plus Exxxtasy

1/ Your receiver will load the bouquet channels approximately as follows (subject to daily change): (1) P505 [radio channel], (2) P502 [radio channel], (3) P501 [radio channel - may not be in use], (4) P504 [radio channel - may not be in use], (5) P503 [radio channel - may not be in use], (6) P207 [KTV] (7) P206 [Formosa News Channel], (8) P205 [Formosa TV], (9) P203 [CTS-China Television Systems], (10) P202 [CTV-China Television], (11) P201 [TTV-Taiwan Television], (12) P973 [Exxxtasy], (13) P964 [Exxxtasy], (14) 204 [FTV].

2/ Space agents are: Sydney (Mr. Ming Leu, 61-2-9687-9903), Brisbane (Mr. Colin Lal, 61-7-3378-8382). A subagent has also been appointed for New Zealand, name not available.

3/ Space requires payment in US\$ in advance of shipment for 50 IRDs and 50 2-year subscriptions at US\$1,770 each (US\$88,500). Their US address is Space TV Systems, Inc., 20519 Walnut Drive, Walnut, Ca. 91789 (fax + +1-909-594-1383).

4/ Meaning- Space Systems will sell its own subscriptions through its own agents, Exxxtasy will do its own marketing with its own agents - about which nothing has yet been announced. Exxxtasy is under contract with a Florida (USA) firm called Americable to deliver a single (adult) channel to US bases in Japan and elsewhere in Asia.

## small, medium and LARGE C and Ku antennas in stock!

Transmit and receive antennas from 1.2m to 13m (Intelsat Standard B). Linear and circular feeds (AsiaSat, Palapa, JcSat, Rimsat, PanAmSat, Intelsat and more) for transmit and receive-only applications. Receive and transmit electronics including inclined orbit tracking equipment with motor drives for elevation and azimuth to 50 tons. Complete system design, fabrication, installation + proof of performance.

P  
A  
C  
I  
F  
I  
C



Limited

A  
N  
T  
E  
N  
N  
A  
S



# SPRSCS '98

JANUARY 29 TO 31, 1998

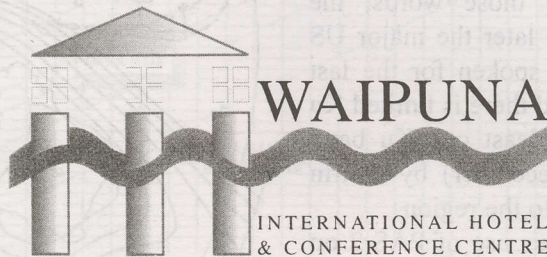

## Auckland, New Zealand

( plus Mark Long SPACE Pacific Certification Course January 27-28)



# ORBITRON

## Antenna Specifications

|       | Dia | F/D   | Gain dBi |         |
|-------|-----|-------|----------|---------|
| Model | M   | Ratio | 4.2GHz   | 12.2GHz |
| SST8  | 2.5 | .36   | 39.2     | 46.6    |
| C10   | 3.0 | .30   | 40.5     | 48.2    |
| SX12  | 3.6 | .36   | 42.2     | 49.5    |
| O16   | 4.9 | .30   | 44.9     | 52.1    |

distributed by



33 Kentia Loop, Wanneroo, W.A. 6065 AUSTRALIA

E-Mail: [pmerrett@omen.com.au](mailto:pmerrett@omen.com.au) <http://www.omen.com.au/~pmerrett>

**Phone: +61 8 9306-3738 Fax: +61 8 9306-3737**



## DIGITAL HARDWARE & SOFTWARE UPDATE 97-6

SatFACTS for May (p. 1) reported that all available transponder space on C-band PAS-2 was spoken for, and only a single transponder on PAS-2 Ku remained available. At the time we wrote those words, the statement was correct. In fact, days later the major US communications company that had spoken for the last Ku band spaces changed its mind and there is limited Ku space remaining as of 1 July. At least one Ku band transponder is being held (until December) by a firm hoping to introduce DTH television to the region.

During the last 60 days the serious use of PAS-2 on the Australia beam has been mostly occasional for limited short term periods. Those days are now gone, forever, and it is no longer possible to ignore the potential users of this spectrum.

Would you be shocked to learn that an MPEG digital TV receiver might find Australia's ABC (national) service along with regional telecaster Imparja on PAS-2? Before July 1st? The photos below were taken June 26 and the receiver in use was a Nokia 9500 S. And

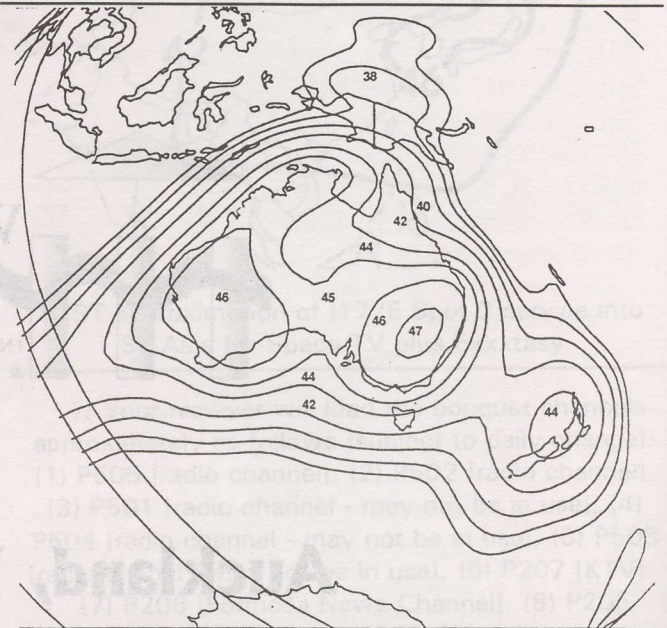

PAS-2 Australia Vertical Beam      Ku-Band  
(CONTOURS: 47, 46, 45, 44, 42, 40, 38, 36 dBW)

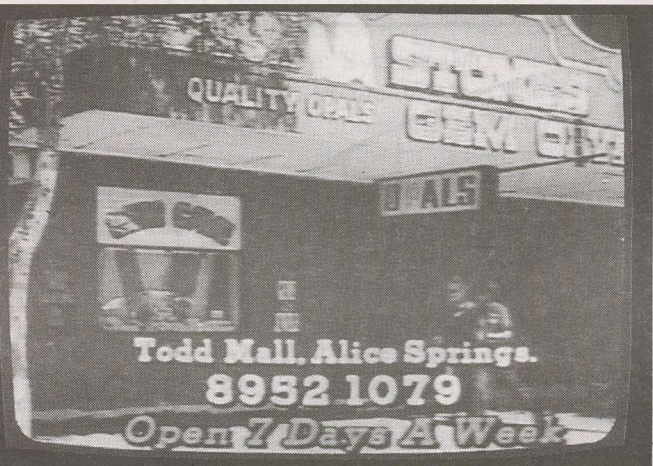
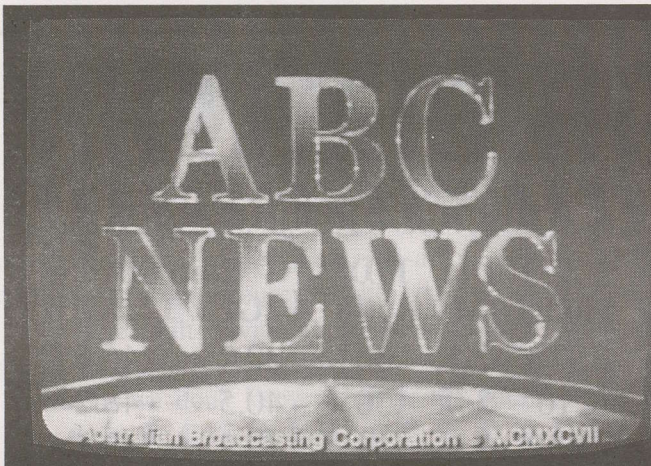

Australia's ABC - national (left) and regional broadcaster Imparja (right) at 2 megabit per seconds on PAS-2 PAS-2 Ku (vertical) as it appears on 3.1m dish in New Zealand (July 1, 1997; see next page )

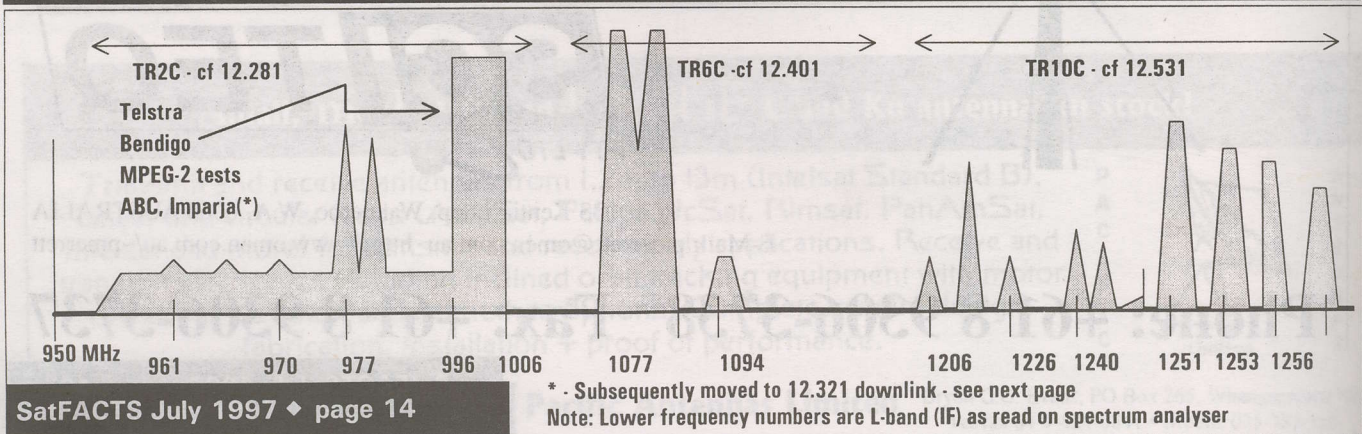



**Minimum Downlink Earth Station Requirements for Bandwidth Limited Operations  
Ku-Band Data Carriers (64 Kbps to 1.544 Mbps)**

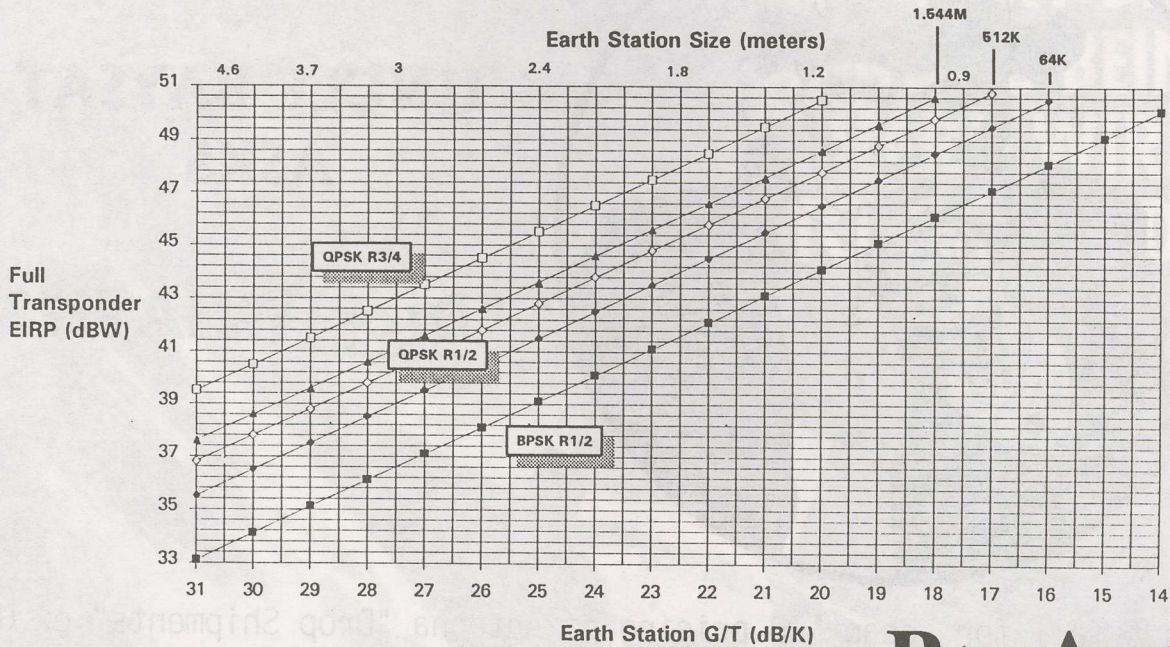

- Notes: 1) QPSK R1/2 C/N=5.3 dB (64 kbps), 5.5 dB (512 kbps), 6.1 dB (1.544 Mbps)  
 2) QPSK R3/4 = 7.9 dB (64 kbps)  
 3) BPSK R1/2 C/N = 3.2 dB (64 kbps)  
 4) Clear Sky Conditions, IBO = 8.0 dB, OBO = 3.4 dB, Gain Step = 11 dB

**PANAMSAT**  
 Engineering & Operations

as the spectrum analyser presentations along the bottom of these two pages illustrates, there is considerable narrowband (data service) activity as well on PAS-2. In short, between PAS-2 and Intelsat at 177E, there is suddenly new reason to have an interest in Ku band beyond the reach of Optus B1 and B3.

The Telstra (Bendigo uplink) testing of low data rate video (2 megabits per second) with the Imparja and ABC services as test signals illustrates the merging of data for data's sake and video at a data rate that is increasingly becoming an option for spectrum hungry bandwidth managers.

**Australian MPEG-2 Video Tests on PAS-2**  
 Receiver downlink frequency: 12.321 GHz;  
 Msym 10.138; FEC 1/2. Three narrow bandwidth (2 megabit per second) video channels: (1) Imparja ["Ch. 1 video 1, Imparja"], (2) ABC ["Ch. 2 video 2, ABC NAB"], (3) "Bob Hinrich's Audio".  
 Service is PAL format DVB PowerVu conditional access (D9223; and recognised by Nokia 2+, Hyundai but not viewable at press time) originating at Telstra Bendigo Uplink (Victoria). Video quality is only fair (VHS tape quality) because of the low megabit rate.

Video can be compressed into extremely narrow bandwidths if the user is willing to give-up some of the benefits of high resolution, full motion reproduction. A telephone (Internet or direct) "video fone" using a variant of MPEG 1 technology can send a limited number of video frames through a standard telephone line each second - a function of compression. As few as 2 frames per second, as many as 15 are possible. The quality, as you might suspect, would win no awards. A relatively static object being photographed and transmitted (such as someone's head talking on the telephone) suffers less in heavy compression and low frame rates than coverage of an auto race or basketball

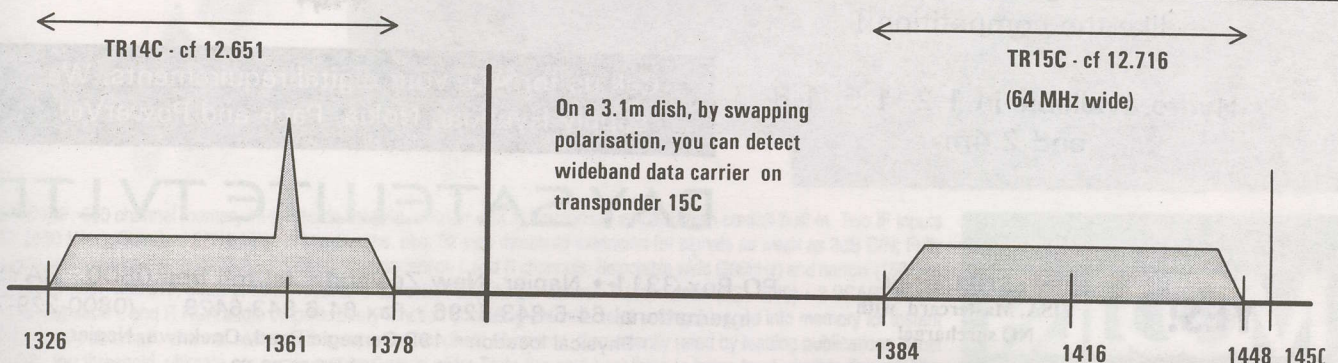





## UNCLE BAYSAT ASKS

**"Drop WHAT???"**

Don't fall for cheap FOB pricing of Antenna "Drop Shipments" ex USA manufacturers. Small savings may be possible via sea (4 - 6 weeks transit!). Would you pay US\$200 or more to airfreight a single 3.0m mesh antenna? And - then you have to deal with the expense and hassle of local customs clearance formalities. **Next day shipment** of a quality US made antenna from Bay Sat makes so much more sense ... and it is cheaper in the long run as well!

The  
**PARACLIPSE**

Hydro  
steals  
the  
show!

(and it won't go to pieces on you  
like the competition!)

-Hydro available in 1.2, 1.5, 1.8  
and 2.4m-

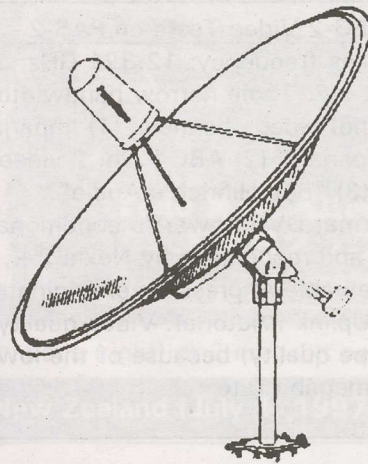

Call us for ALL your digital requirements. We  
supply Hyundai, Nokia, Pace and PowerVu!

## BAY SATELLITE TV LTD

**YES!**

We STILL accept  
VISA, Mastercard with  
NO surcharge!

PO Box 3311 • Napier, New Zealand • tel toll free 0800 - BAYSAT  
International 64-6-843-5296 • Fax 64-6-843-6429 (0800-229-728)  
Physical location • 19B Carnegie Road, Onekawa, Napier

<http://www.baysat.co.nz>  
e-mail [john@baysat.co.nz](mailto:john@baysat.co.nz)

SatFACTS July 1997 • page 16



**THE NEXT BEST  
THING TO BEING  
HARD WIRED  
TO THE BIRD...**



**... The Palcom SL-7900RP  
first choice of satellite  
experts, performance  
conscious installers and  
quality driven consumers  
across the Pacific and Asia.**

SL-7900RP: 500 channel memory Hi-Fi Stereo satellite receiver with full motorised actuator dish control built-in. Two IF inputs (950-2050 MHz); Standard 27/18 MHz IF bandwidths, plus 32 step threshold extension for signals as weak as 3dB C/N; Fully tuneable audio sub-carrier range (5.5-9.5 MHz) independent on L and R channels; Selectable wide (280kHz) and narrow (150kHz) audio bandwidth with J17, 50uS or Hi-Fi 1600 de-emphasis; Full polarizer control; TV modulator (E21-E69) + 3 SCART 21 pin outputs, separate L and R RCA audio outputs. Every function (including antenna, feed settings) logged into memory for instant recall - totally automatic channel search with companion handheld IR remote. Consistently rated by leading publications "Most versatile, low threshold, ultimate consumer receiver" world-wide. Truly, the next best thing to being hard wired to the satellite.

SL-7900RP from Bay Satellite TV Ltd, P.O. Box 3311, Napier, NZ. Tel 64-6-843-5296 (Fax 64-6-843-6429)

with software by....

**PALCOM**

State of the Art Simplicity



### Calculating G/T and C/N For An Antenna System

G/T or gain over temperature is a "figure of merit" rating system for the antenna, the feed and the LNB as a complete system. The calculation uses the antenna gain, the antenna noise temperature and the LNB noise temperature; the latter two in "degrees Kelvin." The answer to the calculation is in dB/K or dB per degree of Kelvin (temperature). In calculating (as opposed to "measuring" with test equipment) the C/N (carrier to noise ratio) of a given signal, you must first know the G/T of the system.

$$G/T = \text{antenna gain} - 10\log(\text{LNB noise temp} + \text{antenna temp in dB/K})$$

$$C/N = G/T + \text{eirp} + 32\text{dB} - 10(\log B)$$

where B = receiver bandwidth in megahertz, eirp = footprint level at your location in dBw and G/T = the figure of merit of the antenna system (above)

Antenna gain (in dB) is found in the antenna manufacturer's data sheet. LNB noise temp(erature) is in degrees Kelvin which is the standard method of "rating" LNBs at C-band (i.e., 20K). At Ku-band, the noise "figure" stated must first be converted to an equivalent noise "temperature" (see mini-table, p.7 of this issue). The antenna noise temperature may be more difficult to identify. This is a function of the antenna look angle (lower look angles have higher noise temperatures because of earth noise pickup), and the selection of a proper feed for the antenna f/D (focal length to diameter ratio). Better quality antenna data sheets provide "antenna noise temperature" for a range of dish elevations (look angles) assuming only that you have selected the proper type of feed for the dish f/D.

Generally speaking, if the LNB noise temperature is improved (made smaller), the dish size is increased, or the look angle increased (i.e., a satellite higher in your sky), the G/T of the system improves.

(Note: Log tables are found in mathematical handbooks and are built into many calculators; receiver bandwidth should match the transmission bandwidth for this calculation and not be an arbitrary less-than bandwidth resulting from user adjustment of a receiver bandwidth control.)

game where the image is constantly undergoing significant change (frame to frame). If you are using an SA D9223 receiver to observe the Telstra Bendigo uplink tests, the status menu function will tell you what the megabit rate (amount of data being transmitted per second) is for the testing. Tests late in June were at the 2 Mb/s rate.

PanAmSat has published data to guide a system planners using relatively low data rate (bandwidth limited) configurations. Their chart (p. 15) illustrates how the size of the dish is affected by the bandwidth (data rate) and the digital transmission parameters in the particular circuit being employed. For example:

1) For a data rate of 64 kbps, in a 43 dBw footprint region (using QPSK 1/2 transmission parameters) the minimum dish size will be 1.9 metres;

2) For the same parameters but increasing the data rate to 512 kbps, the minimum recommended dish size is 2.2 metres;

3) And, for 1.544 Mbps the minimum size becomes 2.4 metres.

This illustrates the rewards inherent in finding a technically acceptable method of reducing the necessary bandwidth for acceptable resolution video to a practical minimum. Better (higher quality) compression techniques are announced almost monthly and represent the "pot of gold at the end of the rainbow" inherent in the entire digital (r)evolution. The first guy to create a system that can send acceptable consumer quality full

motion auto racing or NBA basketball video through a standard 30 kbps telephone modem can retire as a very wealthy man!

The next quantum leap in satellite activity is going to be on Ku; first from PAS-2, then 177 and 180E Intelsats. An announcement from PanAmSat late in June advises that (Australian telephone operator) Telstra is joining with Hughes to provide the North American DirecPC service "to Internet Service Providers ... and household subscribers in Australia." Given the PAS-2 Ku footprint into Australia, dishes in the .9 to 1.2m class are likely. PanAmSat also noted, "Telstra and AAPT Sat-Tel are demonstrating that the opening of Australia's domestic satellite service market will mean more efficient and diverse telecommunication services for all Australians. PAS-2 provides (these two firms) with high-power Ku-band coverage throughout Australia and the added capability of transmitting to Australia directly from throughout Asia and the western United States." Telstra has leased two PAS-2 Ku band transponders, AAPT Sat-Tel one. This is a direct effect of the Australian deregulation which prevented Australian firms from going outside of Australia for their satellite linking needs prior to July 1st.

AAPT Sat-Tel plans to use their single transponder to support private satellite-hubbed networks for wide area networking of data, voice, multimedia and one-way video (as in broadcast signal carriage) applications. And, for high speed Internet services to regional (ISP) locations. The firm is described as, "Australia's third largest long distance telephone company."



# \$49 SATELLITE RECEIVER

COMMERCIAL FLOP / EXPERIMENTER SPECIAL !!

FOR \$49 YOU GET A SINGLE INPUT  
12 CHANNEL K BAND RECEIVER WITH-

- ✓ **SYNTHESISED** IF Tuning
- ✓ **FIXED AUDIO** at 6.5 MHz \*\*\*\*
- ✓ **LED DIGITAL** Channel # Display
- ✓ **REMOTE** Control
- ✓ **MAGNETIC** Polariser Driver
- ✓ **14/18V** LNB Switching
- ✓ **RF** Output (VHF)
- ✓ **EXTERNAL** 17V DC 900 ma power supply

THE PARTS ALONE ARE WORTH OVER \$49 !!

These receivers are surplus stock, bulk purchase, pulled out of a commercial network operating on OPTUS B1 a few years ago.

They are ideal for monitoring video on any K band analogue transponder. A simple one chip PLL audio demodulator can be built to restore the full audio tuning range. It may also be possible to simply modify them for C-band reception (\*\*). Every unit checked and pre-tuned to transponder 7 on OPTUS B1.

Cat # R999 EXPERIMENTERS RECEIVER  
(A)\$49 AS IS (+ freight/shipping).

THESE UNITS are 2nd hand, and have been pre-tested before despatch.

\*\*\*\* A SIMPLE audio demodulator can easily be added to give full range audio tuning; we supply an experimental circuit.

\*\* PHOTOCOPY of circuit and user instructions supplied with each unit.

## AV-COMM PTY. LTD.

Direct Importer ACN 002 174 478  
PO Box 225, Balgowlah 2093

TEL: 61 2 9949 7417 9948 2667

FAX: 61 2 9949 7095

VISIT OUR WEB SITE AT

<http://www.avcomm.com.au>

✓ YES GARRY, Please reserve the \$49 satellite receiver for ...

NAME \_\_\_\_\_

Address \_\_\_\_\_

P'code \_\_\_\_\_

Phone \_\_\_\_\_



a technical and marketing  
advisory

## memo

to the membership from your  
industry trade association

### SPACE Pacific

Satellite  
Programme  
Access  
CommittEe



A trade association for users, designers,  
installers, sellers of private satellite-direct  
systems in the Pacific Ocean & Asia Regions

#### The 1998 Industry Trade Show

SPACE Pacific is pleased to announce the venue and dates for the next South Pacific Region Satellite & Cable Show:

✓ General trade conference and exhibition - January 29-31, 1998;

✓ Mark Long SPACE Pacific Installer Training Course - January 27-28, 1998;

✓ Venue: Waipuna International Hotel & Conference Centre at Mt. Wellington (Auckland), New Zealand.

The first industry meeting was held in Hastings (NZ) in September 1995. The second and third have been held in Auckland at the University of Auckland Tamaki Campus facility. This site has been exceptional for its "perfect fit" to our needs, especially the ease of installing and working on the often complex satellite antenna systems.

However, with no lodging available at the Tamaki Campus attendees found the show bus transport system less than ideal (one trip each day in each direction, forcing you to travel to suit the transport schedule rather than your own).

The Tamaki Campus site for SPRSCS is now history. The Waipuna site provides everything we will need at a single location: exhibit halls, a multimedia equipped 416 seat 'theatre' for our technical sessions, smaller conference rooms for specialised training courses and two on-premise restaurants with companion bars. The master antenna distribution system is equipped to allow us to send a pair of videotape channels to rooms and we

are exploring making tapes of each day's events available on a delayed basis for in-room viewing.

The positives are many - everything happens at one location, no ground transport will be required. This will make the entire 3 (or 5) day conference much more productive as delegates will not be forced to adjust their activities to the transportation (and multi-lodging facilities) of the past. The Waipuna has agreed to a significant discounted rate for suites and twin rooms which makes the overall costs very competitive.

Mark Long is planning a return visit from Thailand to conduct his famous SPACE Pacific Installer Course. As with 1997, this two-day session will occur on the two days immediately prior to the general conference (i.e., on January 27 and 28).

For the first time it will make sense to make attending SPRSCS a family affair. The Waipuna has a saltwater pool and spa complex, a fully equipped gymnasium and a running track around the lagoon where it is situated. And there is 24 hour room service.

SPACE members will receive a detailed invitation for attending SPRSCS '98 after September 1st; registration forms for non-members will also be published in SatFACTS starting with September. The technical and management programme will, in the tradition of SPRSCS, cover aspects of the industry which are on the very leading edge of technology. In an industry that changes significantly month to month, we can but guess the content this far out in front. For now, circle the last week in January for the 1998 South Pacific Region Satellite & Cable Show - in Auckland!

## MEMBERSHIP IN SPACE

Membership in SPACE Pacific is open to any individual or firm involved in the "satellite-direct" world in the Pacific and Asia regions. There are four levels of membership covering "Individuals," the "Installer/Dealer," the "Cable/SMATV Operator," and the "Importer/Distributor/Programmer."

All levels receive periodic programme and equipment access updates from SPACE, significant discounts on goods and services from many member firms, and major discounts while attending the annual SPRCS (industry trade show) each January in Auckland. Members also participate in policy creation forums, have correspondence training courses available. To find out more, contact (fax) 64-9-406-1083 or use information request card, page 34, this issue of SatFACTS. Page space within SatFACTS is donated each month to the trade association without cost by the publisher.



# Year #30\* Filters For Cable TV • TVRO • Interference

## New 100 Page Filter Catalog

Has a filter for every application

- CABLE TV SYSTEMS
- SATELLITE RECEPTION
- OFF AIR INTERFERENCE

### CONTENTS

#### CATV:

HISTORY

BANDPASS FILTERS

CHANNEL DELETION FILTERS:

- Single channel deletion filters
- Multiple channel deletion filters

LOWPASS FILTERS

HIGHPASS FILTERS

CHANNEL REPROCESSING NETWORKS

BANDSPLITTERS (hi/lo diplexers)

PAY TV TRAPS & FILTERS:

- History of CATV trapping

INTERFERENCE SUPPRESSION

NETWORK PASSIVES

DROP LINE DEVICES

WEATHERIZED HOUSINGS

GET  
IT  
TODAY!

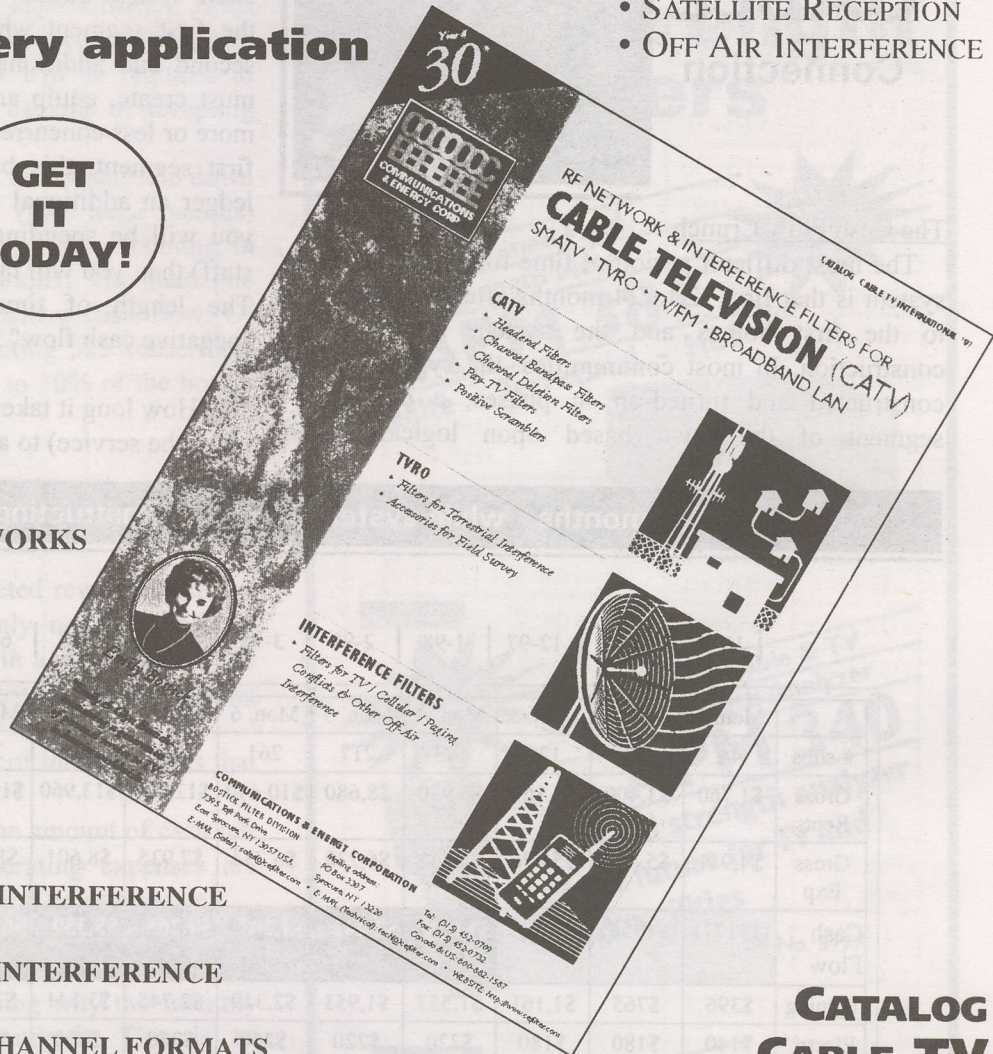

**TVRO:** FILTERS TO SUPPRESS INTERFERENCE

**BOOKS:** CATV, TVRO, MMDS, INTERFERENCE

APPENDIX A: INTERNATIONAL CHANNEL FORMATS

APPENDIX B: INTERNATIONAL CHANNEL FREQUENCIES

APPENDIX C: ORIGIN OF CATV, TVRO, PAY-TV

**CATALOG  
CABLE TV  
INTERNATIONAL/97**

More than a catalog of products-  
It's also a tutorial on CATV history and practices.



Emily Bostick  
President

*Emily Bostick*

\*Emily & Glyn Bostick -  
Continuing a generation  
of personal service to  
TV industries -WORLDWIDE!



7395 Taft Park Drive  
East Syracuse, NY 13057  
Mailing address:  
PO Box 3307  
Syracuse, NY 13220  
Tel: (315) 452-0709  
Fax: (315) 452-0732  
Canada & US: 800-882-1587

## DISTRIBUTOR INQUIRIES INVITED

Telephone: 315-452-0709

Fax: 315-452-0732 USA

Literature: Ileen Feinberg

Technical: Dave Dann, Tracy Warren, Steve Shafer, Glyn Bostick



# The CABLE Connection

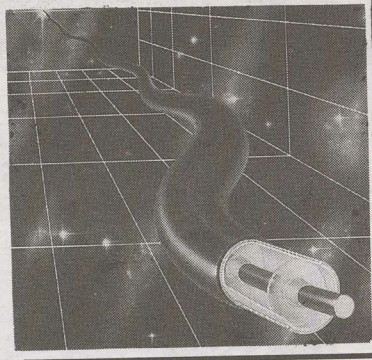

engineering layout parameters. Typically, a community of 1,500 homes will become a system of four or five parts; each segment or phase will pass approximately 20% of the total homes.

Initial construction financing usually assumes the cable system builder will begin receiving revenue from the first segment while construction continues on the second and additional phases. In a system where you must create, equip and staff an office for the business more or less concurrent with the turn on of service in the first segment, this brings to the financial side of the ledger an additional period of negative cash flow; i.e., you will be spending more (to operate the office and staff) than you will take in from the initial subscriptions. The length of time that operations are producing "negative cash flow" will depend upon several factors:

- 1) How long it takes to increase the subscriptions (take up of the service) to a point of positive cash flow;

## The Cash Flow Crunch.

The most difficult period of time for a new cable TV system is that first 12 to 24 months after service begins to the first homes and the system is completing construction. In most communities, the system will be constructed and turned-on in phases; a phase is a segment of the town based upon logical system

**Initial 12 months - while system is under constructing and "turning on"**

| 10-97 | 11-97 | 12-97 | 1-98 | 2-98 | 3-98 | 4-98 | 5-98 | 6-98 | 7-98 | 8-98 | 9-98 |

|               | Mon. 1   | Mon. 2   | Mon. 3  | Mon. 4  | Mon. 5  | Mon. 6   | Mon. 7   | Mon. 8   | Mon. 9   | Mon.10   | Mon.11   | Mon.12   |
|---------------|----------|----------|---------|---------|---------|----------|----------|----------|----------|----------|----------|----------|
| # subs        | 44       | 85       | 129     | 173     | 217     | 261      | 305      | 349      | 393      | 437      | 481      | 525      |
| Gross Repts   | \$1,760  | \$3,400  | \$5,160 | \$6,920 | \$8,680 | \$10,440 | \$12,200 | \$13,960 | \$15,720 | \$17,480 | \$19,240 | \$21,000 |
| Gross Exp     | \$4,911  | \$5,350  | \$5,776 | \$5,842 | \$6,238 | \$6,734  | \$7,935  | \$8,601  | \$8,827  | \$9,383  | \$9,819  | \$10,515 |
| Cash Flow     | (\$3171) | (\$1950) | (\$616) | \$1,078 | \$2,442 | \$4,202  | \$4,265  | \$5,359  | \$6,893  | \$8,097  | \$9,421  | \$10,485 |
| Pgming        | \$396    | \$765    | \$1,161 | \$1,557 | \$1,953 | \$2,349  | \$2,745  | \$3,141  | \$3,537  | \$3,933  | \$4,329  | \$4,725  |
| Electri.      | \$140    | \$180    | \$180   | \$220   | \$220   | \$260    | \$260    | \$300    | \$300    | \$340    | \$340    | \$360    |
| Tel, fax      | \$150    | \$150    | \$150   | \$175   | \$175   | \$175    | \$200    | \$200    | \$200    | \$225    | \$225    | \$225    |
| Techn.        | \$1,250  | \$1,250  | \$1,250 | \$1,250 | \$1,250 | \$1,250  | \$1,875  | \$1,875  | \$1,875  | \$1,875  | \$1,875  | \$1,875  |
| Off Mgr       | \$1,000  | \$1,000  | \$1,000 | \$1,000 | \$1,000 | \$1,000  | \$1,000  | \$1,000  | \$1,000  | \$1,000  | \$1,000  | \$1,000  |
| Off Rent      | \$200    | \$200    | \$200   | \$200   | \$200   | \$200    | \$200    | \$200    | \$200    | \$200    | \$200    | \$200    |
| HE Rent       | \$200    | \$200    | \$200   | \$200   | \$200   | \$200    | \$200    | \$200    | \$200    | \$200    | \$200    | \$200    |
| Acct.-Billing | \$100    | \$130    | \$160   | \$190   | \$220   | \$250    | \$280    | \$310    | \$340    | \$370    | \$400    | \$430    |
| Veh Exp       | \$150    | \$150    | \$150   | \$200   | \$200   | \$200    | \$250    | \$250    | \$250    | \$300    | \$300    | \$300    |
| Maint.        | \$125    | \$125    | \$125   | \$150   | \$150   | \$150    | \$175    | \$175    | \$175    | \$200    | \$200    | \$200    |
| Adv - Promo.  | \$750    | \$750    | \$750   | \$250   | \$250   | \$250    | \$250    | \$250    | \$250    | \$250    | \$250    | \$500    |
| Ins.          | \$200    | \$200    | \$200   | \$200   | \$200   | \$200    | \$250    | \$250    | \$250    | \$250    | \$250    | \$250    |
| Misc.         | \$250    | \$250    | \$250   | \$250   | \$250   | \$250    | \$250    | \$250    | \$250    | \$250    | \$250    | \$250    |



2) How extensive the office and staffing during this negative cash flow period.

In the table shown here, a real system (now under construction) will when completed pass 1,750 homes. The first phase of the system is scheduled to be turned on in October (10-97 in table). The system will continue to be under construction through approximately April (4-98). Between October and April, a level of office and non-construction technical support will be required to operate the portions of the system capable of accepting subscribers.

Cash flow is shown in the fourth horizontal line down from the top line; the grey block (first three months) represents negative cash flow (less money coming in than projected to be spent for operations). The black line with white numbers represents positive cash flow. Of some interest, the system is projecting 525 subscribers by September 1998 which equates to 30% of the homes passed subscribing to cable.

Returning to the cash flow study:

1) The top line ("# subs") indicates the projected number of subscribers at the end of each month of operation;

2) "Gross rpts" indicates projected revenue from the subscribers (for monthly service only, not including any connection fees which is handled in a separate analysis because it represents a capital cost, not an operating expense);

3) "Gross Exp" is the sum of all of the categories that follow below "cash flow";

4) "Cash Flow" as indicated is the amount of cash left in the pot after the monthly operating expenses are deducted from the projected operating gross revenue.

By way of additional explanation, the system will be "sharing" its office facility and personnel with an existing business (thereby explaining why the monthly expenses are below industry standard). This is an appealing approach because it helps keep operating costs down for the first year while cash flow is building.

Programming costs are based upon a monthly average income from each subscriber of \$40 and a cost of programming of \$9 per month; the actual currency involved here is only modestly important.

For all cable systems there is a period when the cash flow is negative. A three month turn around to positive is quite remarkable (but possible); in larger systems with more complex office and staffing requirements, the negative cash flow period may extend well into the second (or even third) year. To keep the business operating during this period requires both careful planning and an investment reserve; money that is actually earmarked at the time of initial construction planning to cover the cash shortfall while the business is gaining customer acceptance. If your funding is coming from a bank or other "strict term" repayment source, making a mistake in estimating the negative cash flow period can be quite disastrous.

# KONIG ELECTRONIC

## Field Strength Meters

KONIG  
ELECTRONIC

Combined Field  
Strength Meter

APM 381

Satellite - Terrestrial - MDS

SK No. 5785

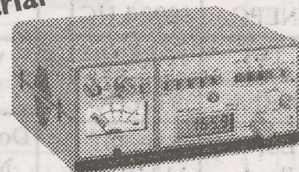

IDEAL  
FOR  
SAT TV - TV  
& MDS  
INSTALLERS

KONIG  
ELECTRONIC

IDEAL  
FOR  
CABLE TV & TV  
INSTALLERS

Hand Held Cable & TV  
Field Strength Analyzer

APM 340

The Field strength analyzer  
of the future for TV and  
CATV facilities

SK No. 5777



KONIG  
ELECTRONIC

Field Strength Meter

APM 746 SAT

Professional multistandard  
field strength meter  
for worldwide  
application

SK No. 5788

IDEAL  
FOR ALL  
PROFESSIONAL  
INSTALLATIONS

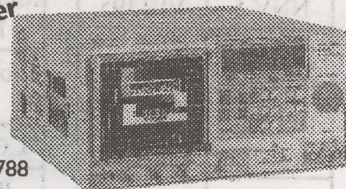

For more information on our full range  
of Konig Service Instruments &  
Specifications please contact:-  
Skandia (61 3) 9819 2466

Distributed in  
Australia & NZ by

**Skandia**

Skandia Electronics Pty Ltd

Victoria: 183 Burwood Road Hawthorn, Victoria 3122 Australia

Telephone: (61 3) 9819 2466 Fax: (61 3) 9819 4281

NSW: Level 1, 39 Terry Street, Rozelle, NSW 2039 Australia

Telephone: (61 2) 9555 2955 Fax: (61 2) 9555 2455



# SatFACTS Pacific/Asian Region Orbit Watch: 15 July 1997

Copyright 1997: SatFACTS, PO Box 330, Mangonui, Far North, New Zealand (Fax: 64-9-406-1083)

| Analogue Free-to-Air 57E to 80E |                   |
|---------------------------------|-------------------|
| Sun Music                       | 57E/703 1400RHC   |
| Sun Mov.                        | 1342RHC           |
| Gemini                          | 1257RHC           |
| Sun TV                          | 1220RHC           |
| AsiaNet                         | 1170RHC           |
| WorldNet                        | 1100RHC           |
| NEPC                            | 1090/LHC          |
| TVi                             | 1020LHC           |
| Muslim                          | 975LHC            |
| ESPN Feeds                      | 64E/801 1134RHC   |
| E-TV                            | 1093/LHC          |
| VIJAY TV                        | 965RHC            |
| Home TV                         | 68.8/Pas4 Vt1310  |
| ABN                             | Hz/1365           |
| Sony TV (Hindi)                 | Hz/1240           |
| Doordar & Iran TV               | Vt/1116           |
| CNNI                            | Hz/1065           |
| TNT/Cart.                       | Hz/1040           |
| ATN                             | Vt/995            |
| BBC World                       | Vt/1350           |
| MTV Asia                        | Hz/965            |
| BBC Interna.                    | 78.5/Th3 Vt/1275  |
| Army TV NNV 5                   | 78.5/Th3 Vt/1395  |
| TK Rossija                      | 80/Exprs 1475RHC  |
| VTV4/ Mos. TB6                  | 80/Exprs 1275RHC  |
| ACT/TB3                         | 80/Exprs 1127/RHC |

| Anal. Free-to-Air 80E to 113E |                   |
|-------------------------------|-------------------|
| Russia 3                      | 80/Exprs 1080RHC  |
| Dub'I II                      | 90/S6 1475RHC     |
| Orbita II                     | 90/S6 1275RHC     |
| Dub'II I                      | 90/S6 1234RHC     |
| Orbita I                      | 90/S6 1208RHC     |
| VTV                           | 91.5/Me1 Hz/1440  |
| Doordar.1 National            | 93.5/In2b 1030/Vt |
| Doordar.1                     | 1160/Hz           |
| Doordar.9                     | 1080/Hz           |
| Doordar.7 Telugu              | 1070/Vt           |
| Doordar.9 Kanada              | 1180/Vt           |
| Doordar.1                     | 1268/Vt           |
| Doordar.                      | 1310/Vt           |
| Doordar.3                     | 1348/Vt           |
| Doordar 4                     | 1388/Vt           |
| Orbita II                     | 96.5/S14 1475RHC  |
| Madagas-car                   | 96.5E/S14 1325RHC |
| ERTU Egypt                    | 100.4/As2 1508/Hz |
| TV Shopping                   | 100.4/As2 1490/Vt |
| Mongolia, Iran                | 100.4/As2 1470/Hz |
| WorldNet                      | 100.4/As2 1265/Hz |
| CCTV4                         | 1190/Hz           |
| RTPi                          | 1170/Vt           |
| Dub'I II                      | 103/S21 1475RHC   |
| ORT                           | 103/S21 1275RHC   |
| CFI                           | 113/C2 990/Hz     |

| Anal. Free-to-Air 113E to 145E |                   |
|--------------------------------|-------------------|
| Brunei                         | 113/C2 1010/Vt    |
| MTV Asia                       | 1030/Hz           |
| TPI                            | 1070/Hz           |
| TV Indosiar                    | 1090/Vt           |
| ABN                            | 1120/Hz           |
| ANteve                         | 1130/Vt           |
| CNNI                           | 1183/Hz           |
| GMA                            | 1230/Hz           |
| TV3                            | 1250/Vt           |
| ATVI                           | 1270/Hz           |
| TVRI                           | 1310/Hz           |
| RTM                            | 1330/Vt           |
| RCTI                           | 1408/Vt           |
| CNBC                           | 1530/Hz           |
| Test Card                      | 128/Jc3 1065/Vt   |
| CETV SD                        | 134/Ap1A 1356Hz   |
| CETV4                          | 1314Hz            |
| CETV2                          | 1272Hz            |
| CNNI                           | 1174Vt            |
| CETV                           | 990Hz             |
| Orbita-I                       | 140/S7 1475RHC    |
| NTV                            | 1425RHC           |
| Music Asia (*B)                | 142.4/R42 1475LHC |
| RAJ-TV                         | 1425LHC           |
| Laos TV (*A)                   | 1375LHC           |
| ViJay TV                       | 1325LHC           |
| EM TV                          | 1272LHC           |
| Dub'I-I                        | 145/S16 1275RHC   |

| An. Free-to-Air 148E to 180E |                  |
|------------------------------|------------------|
| Test Card                    | 148/Me2 1070/Hz  |
| Tests                        | 161/Ag1 1475/Lhc |
| CNNI                         | 169/Pas2 1183/Hz |
| CNN Feeds                    | 169/Pas2 1155/Hz |
| NHK                          | 169/Pas2 1114/Hz |
| TV Shopping                  | 169/Pas2 1400/Hz |
| Feeds                        | 174/I701 984RHC  |
| Feeds                        | 174/I701 973RHC  |
| Feeds                        | 177/I702 984RHC  |
| Feeds                        | 177/I702 963RHC  |
| Feeds                        | 180/I511 1430RH  |
| WorldNt                      | 180/I511 1175RH  |
| RFO                          | 180/I511 1105RH  |
| Feeds                        | 180/I511 1020LH  |
| Feeds                        | 180/I511 984RHC  |

| Encrypted Analogue |                   |
|--------------------|-------------------|
| Discov. India      | 68.8/Pas4 1365/Vt |
| ESPN (d)           | 113/C2 1030/Hz    |
| HBO Asia (d)       | 113/C2 1150/Hz    |
| TNT + (d)          | 113/C2 1390/Hz    |
| Discovery (d)      | 113/C2 1430/Hz    |
| Discovery (c)      | 169/Pas2 1374/Hz  |
| ESPN (a)           | 169/Pas2 1288/Vt  |
| TNT + (a)          | 169/Pas2 1218/Vt  |

## NON MPEG-2 DIGITAL SERVICES

|                           |                   |
|---------------------------|-------------------|
| People's Net (GI 1.5)     | 113/C2 1110/Hz    |
| RPN-9 (GI 1.5)            | 142/G2 1375Lhc    |
| Fox/Prime (SA 1.5)        | 169/Pas2/ 1161/Vt |
| Filipino Channel (GI 1.5) | 169/Pas2/ 1060/Hz |

\* A/ Status of Laos (R42) unclear; has not been reported for several months.  
 \* B/ Music Asia (R42) left air 1 July, apparently moved to PAS-4.

For MPEG-2 format digital, see pages 26/27.



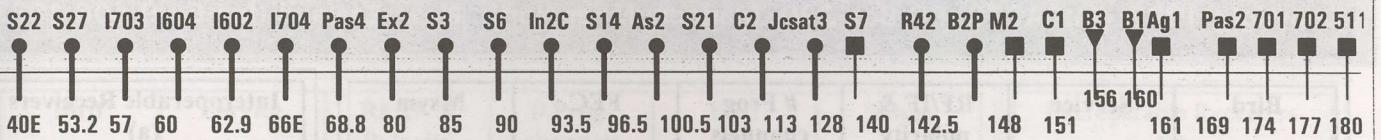

**OPTUS B3  
156E  
(Ku only)**

|                            |                              |
|----------------------------|------------------------------|
| ABC WA                     | 1425/Vt<br>B-Mac             |
| Central ABC<br>HACBSS      | 1393/Hz<br>B-Mac             |
| Imparja                    | 1351/Vt                      |
| GWN                        | 1297/Vt                      |
| Net 9,<br>Sky<br>specials  | 1233/Vt<br>B-Mac             |
| OptusVis.<br>(tests)       | 1250/Hz<br>(MPEG)            |
| ABC NT/<br>Imparja<br>N.T. | 1201/Hz<br>(centre)<br>B-MAC |
| Galaxy                     | 1137/Hz<br>Irdeto<br>Mpeg 2  |
| Galaxy                     | 1073/Hz<br>Irdeto<br>Mpeg 2  |
| ABC SA                     | 1041/Vt                      |

**Optus A3/152E**

|         |         |
|---------|---------|
| ATN7png | 1297/Vt |
| ATN7png | 1430/Vt |

**Palapa C2 Ku  
(seen South  
equator)/113E**

|           |           |
|-----------|-----------|
| Test bars | 11.148/Vt |
|-----------|-----------|

**MeaSat 2  
148E**

|       |         |
|-------|---------|
| Tests | 1065Hz* |
|-------|---------|

\* Colour bars, audio 6.8;  
C-band covers  
Australia., NZ

(a) B-MAC encrypted, no access available; (c) MPEG, encrypted, access may be possible (d) B-MAC, subscriptions available in some geographic areas.

**OPTUS B1  
160E  
(Ku only)**

|                      |                      |
|----------------------|----------------------|
| Net 9,<br>Sky feeds  | 1425/Vt<br>B-Mac     |
| Data                 | 1402/Hz              |
| QSTV                 | 1377/Hz<br>B-Mac     |
| SE ABC<br>HACBSS     | 1370/Vt<br>B-Mac     |
| SE SBS<br>HACBSS     | 1344/Vt<br>B-Mac     |
| NE SBS<br>HACBSS     | 1339/Hz<br>B-Mac     |
| NE ABC<br>HACBSS     | 1313/Hz<br>B-Mac     |
| Sky<br>Channel       | 1296/Vt<br>B-Mac     |
| ABC<br>Radio         | 1276/Hz<br>(digital) |
| OmniCast             | 1270/Vt<br>(FM/FM)   |
| ABC<br>feeds         | 1247/Hz<br>Pal       |
| Sky Nz               | 1245/Vt<br>VidCrypt  |
| Net 9<br>feeds       | 1219/Vt<br>Pal&Ntsc  |
|                      | 1214/Hz              |
| Net 10               | 1182/Vt<br>E-Pal     |
| Net 9                | 1180/Hz<br>E-Pal     |
| Net 10<br>feeds      | 1155/Vt<br>Pal       |
| QTQ9                 | 1145/Vt              |
| Net 7                | 1120/Vt<br>E-Pal     |
| Net 9<br>feeds       | 1091/Vt<br>Pal       |
| CAA air<br>to ground | 1009/Vt<br>Nbfm      |

**PAS-2  
169E  
(C + Ku)**

|                              |                       |
|------------------------------|-----------------------|
| CCTV3,4,<br>test             | 1433.5/Vt<br>(Sa9223) |
| PAS2 tests                   | 1405/Hz               |
| Value Ch.                    | 1400/Vt               |
| Discovery<br>PowerVu         | 1374/Hz<br>(Sa9223)   |
| ESPN                         | 1288/Vt<br>B-Mac      |
| MPEG-2<br>PowerVu<br>Sylmar  | 1249/Hz<br>(Sa9223)   |
| TNT+<br>(1/2Tr)              | 1218/Vt<br>B-Mac      |
| CNN+<br>(1/2Tr)              | 1183/Hz               |
| FoxSports                    | 1161/Vt<br>(Sa9222)   |
| NHK                          | 1115/Hz               |
| Filipino<br>Channel          | 1060/Hz<br>(GI Mpeg)  |
| NBC Mux<br>MPEG              | 1057Vt<br>(Philips)   |
| MPEG-2<br>PowerVu<br>HonKong | 1002Vt<br>(Sa9223)    |
| TCS Sing.                    | 967/Hz                |

**PAS-2 Ku**

|                    |                   |
|--------------------|-------------------|
| Telstra<br>Bendigo | 12.321V<br>(MPEG) |
| Napa TC            | 12,415V           |
| H-Life             | 12,582H           |
| Super Ch<br>Taiwan | 12,485H<br>(MPEG) |
| Bloomb.            | 12.642V           |
| K-TV               | 12,735V<br>(MPEG) |

**Agila 1, ex-Rimsat R41**  
at 161E, Palapa C1 at  
150.5E and B2P at  
144E are functional and  
some narrow band  
services (non-video) and  
testing has been  
reported.

**Intelsat 701  
174E**

|       |     |
|-------|-----|
| Feeds | 963 |
| Feeds | 984 |

**Intelsat 702  
177E**

|                 |                   |
|-----------------|-------------------|
| AFRTS           | 973<br>(PowVu)    |
| Feeds           | 984               |
| Space<br>TV Sys | 12.612V<br>(MPEG) |

**Intelsat 513  
177W**

|       |     |
|-------|-----|
| Feeds | 963 |
| Feeds | 984 |

**(513 Ku)**

|         |          |
|---------|----------|
| Service | RF Freq. |
| US Nets | 10.980V  |
| NBC     | 11.015V  |
| Feeds   | 10.510V  |

**Ku Services**  
Intelsat Ku band  
services shown here  
are boresighted to  
Japan and nearby  
Asia, have not been  
reported south of  
equator. At boresight,  
signals of < 2m levels.

**TDRS5 / 174.3W**

|              |                |
|--------------|----------------|
| Fuji TV      | 1305 Hz        |
| BBC<br>World | 1163Hz<br>MPEG |

**UPCOMING SATELLITE LAUNCHES**

China DF3- location unknown  
Filipino Agila 2 to 144E  
ApStar2A to 77E  
AsiaSat 3 to 105.5E - Oct/Nov

**Intelsat 511  
180E(W)  
+/- 3.1deg.**

|               |                  |
|---------------|------------------|
| TVNZ          | 964/Dmv<br>3000  |
| TVNZ          | 972/Dmv<br>3000  |
| TVNZ          | 980/Dmv<br>3000  |
| TVNZ          | 988/Dmv<br>3000  |
| Occ Vid.      | 1,020**          |
| 9 Aust.       | 1,025            |
| SCPC          | 1,054 **         |
| RFO<br>Tahiti | 1,105            |
| Asian         | 1,130            |
| World-<br>net | 1,175            |
| NHK           | 1,225**          |
| ABC Oz        | 1,256            |
| 7 Oz          | 1,274            |
| 10 Oz<br>MPEG | 1,385<br>(PwRvu) |
| Keystone      | 1,432            |

\* RHC & LHC  
\*\* LHC only

**(511 Ku)**

|     |         |
|-----|---------|
| NHK | 11.135H |
| CBS | 11.475H |
| CNN | 11.508H |

**TDRS5 "north"  
only**



# SatFACTS Pacific/Asian MPEG-2 Digital Watch: 15 July 1997

Copyright 1997: SatFACTS, PO Box 330, Mangonui, Far North, New Zealand (fax 64-9-406-1083)

| Bird                              | Service                   | RF/IF & polarity | # Prog channels    | FEC | Msym                           | Interoperable Receivers (a)  |
|-----------------------------------|---------------------------|------------------|--------------------|-----|--------------------------------|--|
| I704/66E                          | CFI                       | 4055/1095 RHC    | 4                  | 3/4 | 27(.500)                       | N163/17X/2X, HS-100C   |
| PAS-4/68.8E                       | Walt Disney               | 3982/1168 Hz     | 2                  | 3/4 | 6(.632)                        | HS-100C  |
| Thaicom 78.5E                     | UTV                       | 3920/1230 Hz     | 6TV (#1)           | 3/4 | 27(.500)                       | HS-100C, Philips, probably others (Will be CA)                           |
|                                   | UTV/MCOT                  | 3880/1270 Hz     | 6TV (#2)           | 3/4 | 27(.500)                       | HS-100C, Philips, probably others (Will be CA)                           |
| Measat 1/91.5                     | India Bouquet             | 12284/12346Vt    | 10+TV?             | 7/8 | 30(.000)                       | Philips, SK888 (w/CAM)   |
| As2/100.5E                        | European Bouquet          | 4000/1150 Hz     | 6TV, 12 radio (#3) | 3/4 | 28(.125)                       | DMV, HS-100C, Gng, N163, /17X/2X, N2000, P400(b), P500, Pn520/630, Sk888 |
|                                   | Hubei TV (HBTVM Main)     | 3854/1296 Hz     | 2                  | 3/4 | 4(.418)                        | HS-100C, N163/17X/2X, N2000, Ph3950/11                                   |
|                                   | Hunan TV (SRTC)           | 3847/1303 Hz     | 1                  | 3/4 | 4(.418)                        | HS-100C, N163/17X/2X, N2000, Ph3950/11                                   |
|                                   | Guandong TV (GDTV)        | 3840/1310 Hz     | 1                  | 3/4 | 4(.418)                        | HS-100C, N163/17X/2X, N2000, Ph3950/11                                   |
|                                   | Inner Mongolia TV Zizhiqu | 3828/1322 Hz     | 2                  | 3/4 | 8(.397) (1-China) (2-Mongolia) | HS-100C, N163/17X/2X, N2000, Ph3950/11                                   |
|                                   | APTVM London              | 3800/1350 Hz     | 1                  | 3/4 | 5(.631)                        | DMV, HS-100C, N163 /17X/2X   |
| (This service REALLY does exist!) | WTN Jerusalem/ London     | 3790/1360 Hz     | 1                  | 3/4 | 5(.631)                        | DMV, HS-100C, N163/17X/ 2X   |
|                                   | WTN London                | 3786/1364 Hz     | 1                  | 3/4 | 5(.631)                        | DMV, HS-100C, N163/17X/ 2X   |
|                                   | Liaoning TV (Service 2)   | 3734/1416 Hz     | 1                  | 3/4 | 4(.418)                        | HS-100C, N163/17X/2X, N2000, Ph3950/11                                   |
|                                   | Jiangxi TV (JX Sat TV)    | 3727/1423 Hz     | 1                  | 3/4 | 4(.418)                        | HS-100C, N163/17X/2X, N2000, Ph3950/11                                   |
|                                   | Fujian TV (SETV)          | 3720/1430 Hz     | 1                  | 3/4 | 4(.418)                        | HS-100C, N163/17X/2X, N2000, Ph3950/11                                   |
|                                   | Henan TV Zengzhou         | 3713/1437 Hz     | 1                  | 3/4 | 4(.418)                        | HS-100C, N163/17X/2X, N2000, Ph3950/11                                   |
|                                   | Henan TV Main             | 3706/1444 Hz     | 1                  | 3/4 | 4(.418)                        | HS-100C, N163/17X/2X, N2000, Ph3950/11                                   |
| As2/100.5E                        | Sky Racing                | 4015/1135Vt      | 3TV                | 1/2 | 18(.000)                       | Pace DVS-211 (CA)  |
|                                   | STAR TV (Hong Kong)       | 3900/1250 Vt     | 5TV (#4)           | 3/4 | 28(.100)                       | Pace DVS211(CA), DMV, HS-100C*, N163*/17X+/2X                            |
|                                   | "QQQ" China (Shaanxi)     | 3813/1337 Vt     | 1, 1 Radio         | 3/4 | 4(.418)                        | HS-100C, N163/17X/2X, N2000, Ph3950/11                                   |
|                                   | Guangxi GXTV              | 3805/1345 Vt     | 1, 1 Radio         | 3/4 | 4(.418)                        | HS-100C, N163/17X/2X, N2000, Ph3950/11                                   |
|                                   | Rebar TV Taiwan           | 3785/1365 Vt     | 4TV (#5)           | 3/4 | 18(.000)                       | Pv9223 (CA) [Video inverted?]  |

\* / Nokias have 20 second lock-up on NTSC, (some versions of) HSS-100C may have lip sync problems with NTSC.



394.5/1208.543 SEC SA - CB -

C2 - 3936 - TIERNAN 1  
 NBC (SEC - ON ONLY SOMEHOW)

SatFACTS Digital Watch: 15 July 1997 ♦ continued

| Bird             | Service                   | RF/IF & Polarity                                | # Prog. channels              | FEC | Msym     |
|------------------|---------------------------|---|-------------------------------|-----|----------|
| (As2/100.5E)     | Myanmar TV                | 3766/1384Vt                                     | 1TV                           | 7/8 | 5(.080)  |
|                  | STAR TV<br>Hong Kong      | 3700/1450<br>Vt                                 | 8TV<br>(#6)                   | 3/4 | 28(.100) |
| C2/113E          | Star<br>Indovision        | 3500/1650Hz<br>3580/1570Hz                      | 20 TV<br>(#7)                 | 7/8 | 26(.850) |
|                  | MegaTV                    | 3780/1370Vt                                     | 5TV (#8)                      | 3/4 | 27(.500) |
| AP1/138E         | Reuters                   | 3732/1418Vt                                     | 1TV, data                     | 3/4 | 5(.632)  |
| Optus B3<br>156E | Galaxy                    | 12.438Hz (d)<br>12.373Hz                        | 20+TV<br>(#9)                 | 3/4 | 29(.473) |
| Optus B3<br>156E | Optus Vision              | 12.550Hz(d)                                     | 16TV, 8 radio<br>(#9A)        | 3/4 | 29(.473) |
| Optus B1<br>160E | Aurora<br>(MPEG test)     | 12.373Hz  | 4+ TV<br>(#10)                | 2/3 | 27(.500) |
|                  | ABC<br>Exchange           | 12.539Hz<br>12.548Hz<br>12.557Hz                | 1 each                        | 3/4 | 6(.980)  |
| PAS-2<br>169E    | Telstra<br>Bendigo        | 12.321Vt  | 2TV, 1 radio<br>(#11)         | 1/2 | 10(.138) |
|                  | Hong Kong<br>PowerVu      | 4148/1002<br>Vt                                 | 8TV<br>(#12)                  | 2/3 | 24(.430) |
|                  | NBC<br>Hong Kong          | 4093/1057<br>Vt                                 | 7TV<br>(#13)                  | 3/4 | 29(.473) |
|                  | JET<br>Singapore          | 3962/1188<br>Vt                                 | 2TV (1-Ntsc,<br>2-Pal)        | 1/2 | 13(.740) |
|                  | CCTV China<br>PowerVu     | 3716.5/<br>1433.5 Vt                            | 3TV<br>(#14)                  | 3/4 | 19(.850) |
|                  | TCS<br>Singapore          | 4183/967<br>Hz                                  | 2TV<br>(#15)                  | 1/2 | 6(.620)  |
|                  | AAR-ART/<br>RAI Int       | 4153/997<br>Hz                                  | 3TV<br>(#16)                  | 3/4 | 5(.632)  |
|                  | California<br>PowerVu     | 3901/1249Hz<br>12425Vt                          | 8TV<br>(#13)                  | 3/4 | 30(.800) |
|                  | Satcom 1-6                | 3862/1288Hz                                     | 6TV                           | 7/8 | 19(.465) |
|                  | Disney/Aust.              | 3804/1346Hz                                     | 1TV                           | 5/6 | 21(.093) |
|                  | Discovery<br>Singapore    | 3776/1374<br>Hz                                 | 7TV<br>(#17)                  | 3/4 | 19(.850) |
| 1702/177E        | AFRTS                     | 4177/973<br>LHC                                 | 8TV, 12 radio<br>& data (#18) | 3/4 | 28(.000) |
|                  | SPACE TV<br>Systems       | 12.612/1312<br>Hz                               | 7TV, 5 radio<br>(#19)         | 3/4 | 26(.694) |
| 1511/180E        | TVNZ<br>Gennet<br>(feeds) | 4186/964,<br>4178/972,<br>4170/980,<br>4162/988 | 1 TV typical<br>each          | 3/4 | 5(.631)  |
|                  | Canal Plus                | 4096/1054<br>LHC                                | 1TV (?)                       | 3/4 | 34(.368) |

| Interoperable Receivers<br>(a)                                       |
|--|
| HS-100C  |
| Pace DVS-211 (CA),<br>HS-100C, N163/17X/2X                           |
| Pace DVS-211 (CA)  |
| HS-100C  |
| N163/17X/2X  |
| Gng, P400, P500, Pn520,<br>Pn630, Sk888 (c)                          |
| (when testing is over, only<br>IRDs with CAM)                        |
| N163/17X/2X, HS-100C   |
| Pv9223, HS-100C, N2X<br>(FTA)  |
| Pv9223, HS100C, N2X<br>(Pv CA)                                       |
| Pv9223, HS-100C(*), N2X*<br>(some FTA)                               |
| HS-100C, Gng,<br>N163/17X/2X, P400 (b),<br>P500, Pn520, Pn630, Sk888 |
| Pv9223 (CA)  |
| Pv9223, HS-100C,<br>N163/17X/2X (FTA)                                |
| Pv9223, HS-100C<br>N17X/2X (FTA)                                     |
| Pv9223,<br>N17X/2X, (continues FTA)                                  |
| Pv9223, HS-100C (*)<br>N17X/2X (*), (some FTA)                       |
| Pv9223 (CA)  |
| Pv9223 (CA)  |
| Pv9223, HS100C, N2X<br>(occasionally Ch. 2 FTA)                      |
| Pv9223 (CA)  |
| Pv9223, HS100C, P2X<br>(will be CA only)                             |
| DMV, N17X, 2X<br>(not all channels hot at all<br>times)              |
| Sagem ISD 2050 (?)   |



## SatFACTS MPEG-2 Digital Watch: 15 July 1997 ♦ Support Data

**Receivers:** (a) By our definition, a receiver is deemed "fully interoperable" when it will turn on and routinely receive the service in question with no persistent glitches, no special tricks (such as loading software from an external source). Receivers in abbreviated listings are those that have shown these qualities for the transmission service listed. There is a time lag of up to 30 days after introduction of new receivers before sufficient data is accumulated for inclusion here. Nomenclature: DMV is DMV/NTL 3000 (a professional model receiver); HS-100C is Hyundai HSS-100C, designed for China; Gng is Grundig DTR1100 (manufactured by Panasat - see SF#31, p. 15); N163 is Sweden sourced Nokia 9500 S with version 1.63 software; N17X is German/European Nokia "d-box" software modified for C-band use; N2000 is Nokia sourced IRD created for Chinese SCPC market with AsiaSat 2 and Intelsat manual search software; N2X is May/June 1997 version of 9500 S; Pace DVS-211 is Indovision (+ Sky Racing) CA only receiver also used by Sky on As2; Ph3950/11 is rack mount Philips DVB IRD created for China SCPC project; P400 is Pace DGT400; P500 is Pace DVR500; Pn520 is first version Panasat (July 1996); Pn630 is latest version Panasat (February 1997); Pv9223 is PowerVu by Scientific Atlanta; Sk888 is Skandia DigiSkan. (b) P4500 (DGT400) will only work with EBB (et al) when it has not been over the air enhanced (upgraded); (c) SK888 will not work with conditional access (pay) services.

**Bouquets:** 1) Thailand UTV: (1) CNN, (2) TTV, (3) ESPN, (4) HBO, (5) Ch. 5, (6) itv; 2) Thailand UTV/MCOT: (1) Ch. 9, (2) Discovery, (3) Ch. 3, (4) TNT, (5) Star Sport, (6) Ch. 7; 3) European Bouquet. (1) Deutsche Welle, (2) MCM, (3) RAI International, (4) RTVE, (5) TV5 Paris, (6) [when operating] Deutsche Welle special programme channel with MediaNet VBI included [lines 10-15, requires DMV M2/Pro/Txt board inserted in 3000 series receiver]; Radio (1) DW#1 (stereo), (2) DW#2 (stereo), (3) DW#3 (stereo), (4) YLE (left) & RCI (right), (5) SRI (l) & WRN (r), (6) REE, (7) DW#1 (stereo), (8) DW#2 (stereo), (9) DW#1 (stereo), (10) NN RA6, (11) NN RA8; 4) STAR TV Hong Kong. (1) Sky News London, (2) Sports Contribution, (3) Channel [V] International, (4) Star Movies Japan [NTSC], (5) Star Plus Japan [NTSC]; 5) Rebar Taiwan. (1) "U1" [movies], (2) "U2" [news], (3) "U3" [sport, cartoons, general entertainment], (4) "Rock TV"; 6) STAR TV Hong Kong. (1) ESPN Contributory, (2) Racing Ch., (3) Star Movies SEA, (4) Star Chinese, (5) NBC, (6) CNBC, (7) Sky News, (8) VIVA Cinema; 6) Indovision. (1) HBO Asia, (2) STAR Movies SEA, (3) Film Indonesia, (4) MGM Gold, (5) ESPN Asia, (6) STAR Sport, (8) Channel 'V' International, (9) Channel 'V' Asia, (10) RCTI, (11) STAR +, (12) Discovery, (13) STAR Movies and NBC Asia, (14) Phoenix Chinese, (15) CNN, (16) BBC World, (17) CNBC, (18) Cartoon + TNT, (19) Preview 1, (20) Preview 2; 8) MegaTV. (1) CNNI, (2) Discovery, (3) ESPN Asia, (4) HBO Asia, (5) Cartoon + TNT, [(6) MGM Gold, (7) Cinemax (6-7 not operating)]; 9) Galaxy. Presently 20+ programme channels. 9A) Optus Vision tests of 16 programme channels, programming decisions to be finalised; 10) Aurora. (1) TVSN, (2) Australia Sky News, (3) Wide screen test, (4) Tests; 11) Telstra Bendigo. (1) Imparja, (2) ABC, (3/15) Hinrich's Audio; 12) Hong Kong PowerVu. (1) CTN 1, (2) CTN II, (3) TVBI Hong Kong, other feeds [NTSC], (4) Ad-hoc 1 PA [PAL], (5) Ad-hoc II [NTSC], (6) ABN, (7) CTN II, (8) CTN; 13) NBC Hong Kong. (1) CNBC, (2) CNBC Mandarin A, (3) NBC Asia, (4) colour bars, occasional feeds, (5) CNBC Taiwan, (6) NBC "2" Asia/Taiwan, (7) Colour bars, "future" use; 14) CCTV China. (1) CCTV4, (2) CCTV3 [(3) CCTV tests, (4) CCTV4, (5) CCTV5, (6) CCTV8]; 15) TCS Singapore. (1) TCS Test, (2) TCS Default [repeats channel 1]; 16) SCPC3. (1) ad-hoc use, (2) AAR/ART, (3) RAI International; 17) California PowerVu. (1) CMT(NTSC), (2) CBS feeds, others including CTV Canada (NTSC), (3) [Greece] Antenna 2 (NTSC), (4) EWTN (NTSC) global Catholic radio, ch. 2, (5) BBC World (NTSC), (6) Bloomberg Financial (NTSC), (7) Golf Channel (NTSC), (8) ESPN (NTSC); 18) Discovery. (1) Disc. Aust/NZ, (2) Disc. default, (3) Disc. Japan, (4) Disc. SE Asia, (5) Disc. Taiwan, (6) Disc. Philippines, (7) Disc. China; 19) AFRTS. (1) News, Sports [ACII, CW, RR, 9.6 kbps, TV], (2) Spectrum [Urban, 64 kbps], (3) AFN Pacific [TV], (4) Channel 1 - Mirror [TV], (5) AFN Korea [contingency, 1.536, TV], (6) The Jim Lambert Test Channel [!!!], (7) EPG, voiceline, (8) EPG, u/i voiceline, (9) AFN Atlantic [Top 40, HR, NPR, TV], (10) AFN Americas [Top 40, TV], (11) AC1, (12) Country, (13) Adult Rock, (14) NPR [US National Public Radio], (15) Urban, (16) Pure Gold, (17) Top 40, (18) Hard Rock (19) Contingency.; 20) SPACE Systems (in loading order). (505) Radio, (502) Radio, (501) Radio, (504) Radio, (503) Radio, (207)KTV/ sport/talk, (206) Formosa News Channel, (205) Formosa TV, (203) CTS/China Television Systems, (202) CTV/China Television, (201) TTV/Taiwan Television, (973) Exxtasy was here, (964) Exxtasy was here, (204) Formosa TV (sometimes duplicates 205; also has Mandarin dubbed US [English] movies).

NOTE: Listings in **bold face** are PowerVu transmissions that are typically (but not always) FTA (free to air).

### **MPEG-2 DVB RECEIVERS:** [Data here is believed accurate; we assume no responsibility for errors in this volatile area!]

**DMV/NTL 3000.** Skandia Electronics Pty Ltd (tel 61-3-9819-2466)

**Espano.** Antares Satellite (tel 61-7-3205-7574) Note: Still not available as of July 7.

**Grundig (Gng) DTR1100.** Av-Comm Pty Ltd (tel 61-2-9949-7417)

**Hyundai-TV/Com.** Model HSS-100C is officially available from Pacific Satellite (tel 61-7-3344-3883) and Skandia Electronics (tel 61-3-9819-2466).

**Nokia 9500 S (V1.63).** This version is no longer available although it had ability to identify Msym and FEC parameters of unknown carriers. (V1.7X) was a German language "d-Box" version originally imported by OPAC; it functioned with the same parameters as the V1.63. (V2.X; 2.233, 2.034 and others perhaps not yet identified) are current (late June/July) software versions that allow virtually unlimited stacking of bouquets and programmers and for at least the 2.233 version also allow limited red menu correction of NTSC glitch. Sources known include: AV-COMM Pty Ltd (Tel 61-2-9949-7417); Pacific Satellite (61-7-3344-3883), SCITEQ (61-8-9306-3738).

**Nokia "d-box"** (V1.7X) suitable for C-band use. Instructions, on-screen prompts may be in German. No longer available.

**PACE DVS-211.** Indonesian sourced; try Nationwide Antenna Systems in Qld. (tel 61-7-3252-2947) in A\$2,500 range including year's programming for Indovision on C2.

**PACE DGT400.** Through Galaxy offices, Australia.

**PACE DVR-500.** Bay Satellite TV Ltd. (tel 64-6-843-5296)

**Panasat 520 (Pn520).** OPAC Pty Ltd (tel 61-2-584-1233)

**Panasat 630 (Pn630).** Antares Satellite (61-7-3205-7574)

**PowerVu D9223.** Scientific-Atlanta (Sydney) Tel 61-2-9452-3388; BaySat (tel 64-7-843-5296)

**SAGEM ISD2050.** SAGEM SA, Mrs. Salima ALAOU (tel 33-1 40 70 63 63)

**Samsung VS-2000 (ver 1.31).** Pacific Satellite (tel 61-7-3344-3883)

**SK888.** Skandia Electronics Pty Ltd. (tel 61-3-9819-2466)



# WITH THE OBSERVERS

Digital receivers that will acknowledge the presence of bouquets which cannot be accessed (for viewing) is becoming an increasing challenge as the universe of supposedly free to air digital services grows. Observers report bouquets which the Nokia (9500S) will not properly access (i.e., Mega TV on Palapa C2) and others which the Hyundai (HSS-100C) will not access (i.e., RAI/AAR-ART on PAS-2) while the Nokia will.

"MPEG-2 DVB Compliant" is, of course, a mockery of what was to have been an all industry, all-world standard. It is with some amusement that we learn of a Scientific-Atlanta D9223 purchased by observer **Francis Kosmalski** (Auckland, NZ) last January and returned to SA in Sydney in June for a "software upgrade." Kosmalski has been insistent that SA "make good" on his perceived promise from them that his receiver would access not only PowerVu but also any other "DVB Compliant" service. The receiver arrived back in Auckland early in July, and on PAS-2 immediately showed promise accessing a range of PowerVu and non-PowerVu services (including NBC, RAI/AAR-ART). The real test would be on AsiaSat 2 where DVM format services (STAR TV) and a multitude of SCPC (Chinese) services operate. With the assistance of Robin Colquhoun (at Robin's location where As2 is visible) here is what they found:

1) The "Kosmalski Software" supplied by S-A accesses all of the (FTA) MPEG-2 services listed in this publication on AsiaSat 2, PanAmSat 2 as well as Galaxy (Shopping Channel) and Optus Vision tests.

2) There are no glitches or hang-ups, although Robin suggests the receiver brings up the audio "slightly slower than (my) Nokia 2.233."

3) Robin reminds present and would be D9223 "Kosmalski Software" version users that SA does not, will not, make any guarantees as to how many of the various FTA MPEG format services the receiver will access, this being a function of the software data stream's adherence to the "DVB Compliant" rules (i.e., the very standard which SA chose not to follow when it brought out their PowerVu format receiver).

What this tells us is that "*SA has finally gotten it right*," 13 months after first announcing the "DVB Compliant capability" of this popular industrial grade receiver. Now, where does this leave the rest of the industry?

Subject to payment of a fee (under A\$100), and transport to and from Sydney, this same software can be added to other D9223s. Note: There is no confirmation from SA that this

## AT PRESS DEADLINE

Intelsat 802, successfully launched late in June, reported near 160E and drifting towards 174E July 7. Satellite will "stop" and test at some location other than 174, possibly 172, and observers should watch for new signals on C-band in particular over the next few weeks. When testing is completed, to 174E while 701 now at 174E goes to 180E to replace 1511 (at long last!).



SatFACTS May 1996 reported our "Adios" to a 5m aluminium and steel dish originally installed by the editor in 1990. Enthusiast Alan Meharry, Te Aroha (NZ) hauled it off in pieces and now, a year later, the 5m is reinstalled and playing again.

software mod will function with "all" versions of the 9223; there could be some disappointments here and as we learn more, we will advise. Start by calling Elizabeth Jennison at SA Sydney 61-2-9452-3388 (fax 61-2-9451-4432). Know (from the rear deck of the receiver) the (a) TID# (typically 12 digits), (b) UA# ( typically 7 + 1 digits), and, (c) Rn# (starts D9223- (10 characters) (3 digits) (3 digits), before you call. And the approximate date of purchase if possible.

**WITH THE OBSERVERS:** Reports of new programmers, changes in established programming sources are encouraged from readers throughout the Pacific and Asian regions. Information shared here is an important tool in our ever expanding satellite TV universe. Photos of yourself, your equipment or off-air photos taken from your TV screen are welcomed. TV screen photos: If PAL or SECAM, set camera to f3.5-f5 at 1/15th second with ASA 100 film; for NTSC, change shutter speed to 1/30th. Use no flash, set camera on tripod or hold steady. Alternately submit any VHS speed, format reception directly to SatFACTS and we will photograph for you. Deadline for August 15th issue: August 4 by mail (use form appearing page 34), or 5PM NZST August 5th if by fax to 64-9-406-1083.



## NOKIA Mediamaster DVB 8200 S Free To Air

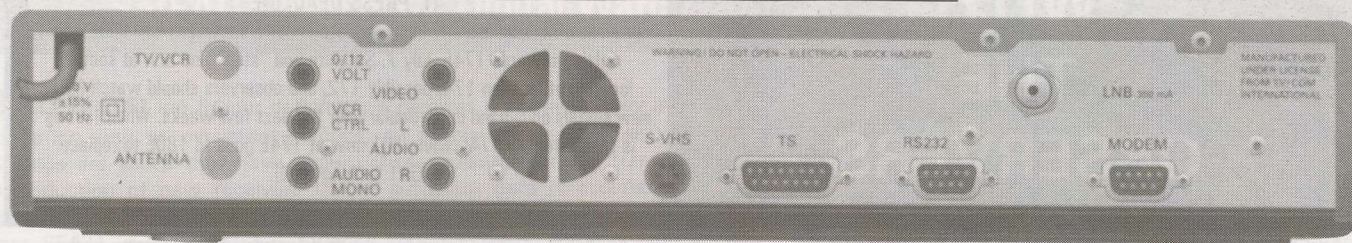

Nokia has been "listening" to suggestions and their recently announced 8200 series unit may be the closest thing to an "all-singing, all-dancing" receiver to appear in the marketplace to date. A data sheet distributed in Europe recently tells us the following: (1) The receiver has an RCA video output jack, an S-VHS mini-DIN jack, and no SCART outputs; (2) The demodulator is SCPC and MCPC capable, QPSK, covering transmission bandwidths from 2 to 54 MHz; (3) It will be equipped with a Motorola 68340 (16 MHz) processor, 1 Mbyte of RAM memory and 1 Mbyte of flash memory; (4) The RF tuner covers 950-2150 MHz with 13/18V (22 kHz) switching, (5) Modem and Serial data interfaces (RS232, 19.2 kbaud), (6) PCMCIA (smart card) conditional access. No, your eyes do not deceive you - just left of centre is a fan (!) with data sheet claims the receiver will function in an operating temperature environment of +5 to +45 centigrade (9500 S models have some difficulties at 40C). A UHF remodulator is included (adjustable over 470-862 MHz) but no indication of which format(s) for the remodulated signal. The promised model which Nokia claims will do FTA PowerVu as well as PAL format MPEG-2 DVB is likely to be a software version of this receiver. Latest on when it will be released? Nokia is still saying jabberwockery August but we suggest it is more likely to be September or October.

Now, if you think this is an approval on our part for recommending the SA D9223, think again. Each time you change bouquet with this receiver, all of the parameters must be entered anew through the installer menu. Within a bouquet, you can scroll up and down the FTA services (from the Napa test service to the new Greek Antenna 2 to EWTN to BBC to Bloomberg, for example, on the California bouquet); the conditional access services will simply appear as a blank screen with "no authorisation" printed at the top. To go to NBC or the Hong Kong bouquet, you re-enter the installer menu, select the on screen parameters to save, use the keypad to make changes and save each change, and then finally tell the receiver to "view" the result. At this point you are back to scrolling within that particular bouquet. The SCPC Chinese services cannot be scrolled as each one is a separate installer menu entry. This may be satisfactory for an enthusiast, or commercial user; it is probably not the correct answer for a consumer.

A "super enthusiast" will find all of the following tools useful:

- 1) A spectrum analyser with which you can identify the presence of new SCPC and MCPC service transmissions, to an approximate (L-band) frequency;
- 2) A Nokia V1.63 with which you can enter the approximate frequency and then when you have that number within 2 or 3 MHz of the correct frequency, the Nokia will "lock on" to the signal and using its own clever software tell you the precise downlink frequency plus the Msym rate and FEC (none of which you would have known previously);
- 3) An SA D9223, Hyundai HSS-100C, Nokia "e3" version 2.233 with which you can access most (but probably not all) of the PowerVu and other non-PowerVu FTA services.

For the "average consumer?" Identify the bouquet or bouquets you most wish access to, and then select the receiver that does this bouquet best (see tables on pages 26-28, here). If, after being dealer set-up, the receiver can not go from

service to service with a point and shoot remote, it probably is not the right box for a typical consumer.

### Tests and Changes

The STAR TV As2 services on 3700 and 3900 (vertical) were significantly reconfigured during June; see changes on p. 26. "ESPN Contribution" on 3700 is often in free to air format with sport and news feeds. The 3900 feeds changed their FEC from 1/2 to 3/4; if your receiver already had the old (1/2) in memory before the change, deload this bouquet from the receiver memory and reload using the new FEC number (or, you cannot access the after-change services).

Similarly, when Telstra brought up Imparja and ABC National on PAS-2 Ku late in June, the Msym was 10.100. Some receivers that memorised that rate found they were locked out days later - the rate had been increased to 10.138. And, after July 4th the downlink frequency moved from 12.300 to 12.321 and at the same time this PowerVu service went from 4 to 3 bouquet channels and then to conditional access on July 5. Of interest, there were several days when a D9223 outside of the CA code would not access the service while a Nokia e3 V2.233 would still allow you to watch (and listen). Alas, by July 6th only CA approved receivers could get into this one. This is a "test" and expect formats other than PowerVu to be operational for extended periods before testing is completed.

Attempts to locate and create tuning parameters for the Space TV Systems C-band feed on I180 have been partially successful, but the present sorry condition of I180 signals (now in the last months of its inclined orbit operation) make much more than identifying the service impossible; this may all change (for the better) when I701 at 174E moves to 180E in September.

An announcement within a late June broadcast of the "HBN" programme (PAS-2, Ku 12.640Vt) advised viewers to "switch polarisation" (to horizontal) for subsequent editions. Of note, while the primary Australia/NZ PAS-2 Ku beams are vertical (see p. 14), this satellite also has 3 horizontal transponders capable of serving either China or Australia/NZ (PanAmSat



selection choice): 7C (12.466), 9C (12.591) and 15C (12.716 [centre frequencies]). On both polarities, levels are in the 44-46 dBw region. For Herbalife, newly on 12.582 (IF 1282)Hz, M-W-F 2200Nzt/2000AEST.

Observer **Dennis Ditcham** (WA) reports Intelsat 704 (66E) carrying special Fox Sports Wimbledon '97 services (4016Vt) late in June. Fox Sport has recently concluded a deal with two USA major sporting channels and we can expect a far more aggressive Fox Sport world net in the coming months.

**Gregorio V. Hermosa, Jr.** (Oman) provides a detailed report of recent observations from his location. On PAS-4 (68.5E) he finds an encrypted French language channel in NTSC 12.591Vt; and SAT 7 (an Arabic language, Catholic channel from Cyprus) on 4040/1110Hz Fridays 1430-1630 Oman time. And, ATN on PAS-4 has changed to 4155/995Hz. He also reports seeing encrypted transmissions from ERTU (Egypt) on As2 at different times (not always encrypted); the Egyptians still refuse to reveal their plans for this service channel and rumours of eventual encryption persist. He also reports what he believes to be E-TV on 4057LHC from Intelsat 801 (64E). Gregorio also reports that "at home" in the Philippines, local DTH installers are selling (US)\$2,000 system packages that receive the Japanese BS 3A/B satellite Ku service (from 110E); two channels of NHK television (one Japanese, one English). BS 3A/B have a separate footprint service for Okinawa which apparently also spills south-west into the Philippines. Thaicom 3 at 78.5E has recently been seen with NNV 5 on 3755/1395Vt (at P4 level on 2m dish) along with BBC International on 3875/1275Vt (P3).

Mabuhay 1 (Agila 2) satellite for the Philippines footprint from 144E (change from previous 153E) shows no forecasted usual signal levels further south-east than Indonesia. Eirp of 41.5 dBw into boresight centre (Thailand; see sketch map, below), secondary footprint to Hawaii at 37 dBw peak. Satellite is booked on Long March, which translates to a launch date of - "when it happens, it happens."

**Peter Merrett** (Sciteq) advises, "Gardiner is replacing their 12.15-12.75 LNBs with an LNBF, to be available in August and at lower pricing than the existing LNBs."

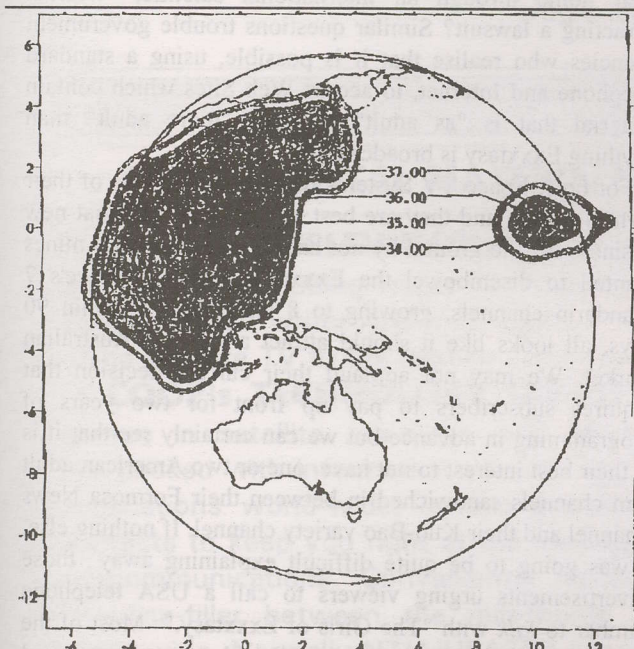

C-band eirp from Mabuhay-1 (Agila 2) scheduled to 144E for Philippines via Long March launcher

**Distribution centre of DVB MPEG-2 digital receivers for FREE-TO-AIR satellite TV programmes.**

**Wholesale & Retail Welcome**

Consumer grade ---  
**HYUNDAI (HSS-100C),  
NOKIA (DVB 9500S),  
PACE (DSR 200)**

Professional grade ---  
**DMV (System 3000),  
Hirschmann (DVB7500)  
Philips (DVS 3950/11)**

Satellite IF distribution equipment --  
**GLOBAL.**

Come and visit us if you pass by Hong Kong!

Hong Kong Satellite TV Ltd., Unit C, 7/F, Block 6, Tien Chu Centre, 74 Pak Tai St, Tokwawan, Kowloon, HONG KONG  
tel: (852)2736-8703  
fax: (852)2735-0583  
email: hkstv@netvigator.com

✓ YES, please send me info about \_\_\_\_\_ brand Company \_\_\_\_\_  
Detail address: \_\_\_\_\_  
\_\_\_\_\_ p'code  
Tel: \_\_\_\_\_  
Fax: \_\_\_\_\_

## NOT COMING TO A NEWSAGENT NEAR YOU

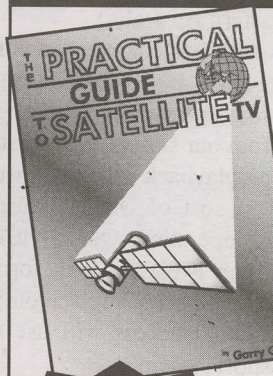

**NEW!**

### THE PRACTICAL GUIDE TO SATELLITE TV

116 easy to read pages, explaining the history, theory, operation and installation of *HOME SATELLITE TV* systems.

21 explanatory photos, tables, graphs and diagrams.

46 pages of satellite orbital data, transponder loading, footprints for every satellite covering Australia and neighbouring countries and comprehensive glossary of terms.

**AVAILABLE NOW - \$39**

**AV-COMM PTY LTD**

A.C.N. 002 174 478

198 Condamine Street,  
Balgowlah NSW 2093

Tel: (02) 9949 7417/9948 2667

Fax: (02) 9949 7095

<http://www.avcomm.com.au>

✓ **YES GARRY, Please send me 1 x Practical Guide to Satellite TV priced at \$39 + \$5 p&p (NZ \$8 p&p)** Australian \$ only

Credit Card

Signature \_\_\_\_\_

Name: \_\_\_\_\_ Expiry Date: \_\_\_/\_\_\_/\_\_\_

Delivery Address: \_\_\_\_\_

P'code: \_\_\_\_\_ Phone: \_\_\_\_\_



# AT

## Sign-off

### The Exxtasy Affair

The return of Exxtasy, within the Space TV Systems bouquet, is problematical. It appears the service was yanked off of the Mandarin bouquet because of three problems:

1) They could not send Exxtasy only to the Asian beam (spot 2) once the bouquet left Brewster, Washington; Australia and the South Pacific got it whether we wanted it or not.

2) The people at Space TV Systems got nervous, very nervous, about the possibility that the Australian authorities might create a legal fuss over the importation into their country of naked bodies engaged in triple-X activities.

3) The distinction between Space Systems' package of Mandarin language channels and the Exxtasy pair of English language channels was not very clear. In fact, naked bodies were but a button push away from the far more sedate Taiwan originated programming.

Back in December, Space Systems' Michael Lin was offering use of their "spare transponder capacity" to anyone with an interest in taking the service. Here are some of the details of what they offered:

1) "Space TV Systems will be occupying only a part of a 72 MHz wide transponder (1702 at 177E). Intelsat forecasts the beam centre into the eastern part of Australia will be 45.5 dBw. In normal operation we need to have a total of 5.5 dB power back-off. We have an agreement from Intelsat that because the remainder of the 72 MHz transponder will not be in use, we may increase the downlink power (back) to 45.5 dBw if there is heavy rain in our service area (i.e., eastern Australia).

2) "To sublease from us a 4 Mbps data rate compressed video channel in MPEG-2 DVB, the charge will be US\$840,000 per year. This cost will cover compression, encryption, conditional access control and up-link services from our station in Brewster, Washington. If you require video tape playback service as well, our playback format is BetaCam at a cost of US\$15,000 per month for 24 hour attended playback operation. Our DiviCom MPEG-2/DVB encoder can accept either NTSC or PAL format input and the MTI manufactured IRDs we plan to use can output in either PAL or NTSC. Our conditional access will use the Titan Information Digital Video Passport system.

3) "Our company is allowed to transmit 'adult materials' in encrypted form through 1702 and the (US) FCC allows us to uplink encrypted adult pay TV services as well."

This information is excerpted from a proposal submitted by Space TV Systems to a would-be adult programming package operator last December 4th. What it tells us is that while Space may not have understood the complications arising from offering their spare bouquet bandwidth to Exxtasy, they certainly were fully aware of the needs and requirements of adult channel operators.

Nobody knows for certain, least of all me, that the content of the Exxtasy Channel is in fact illegal to sell in Australia. What is clear is that if the same programming content was uplinked



Sugar and Spice and everything nice ...

Dial the girls of  
**Exxtasy**

**1-800-294-7327**

\$2.99-\$4.99/minute  
For credit cards  
Must be 18 & over

from within Australia, the people doing the uplinking would be under significant threat from various government authorities. Even in New Zealand, where the laws regulating adult features are somewhat less exact, it is very unlikely you could uplink (i.e., broadcast) the content of a typical Exxtasy flick without being charged with violating several public morals acts.

So the to-be-tested legal question comes down to "Can an Australian (Kiwi) subscribe to a foreign uplinked adult movie service which he or she receives in the privacy of their home through an international satellite," without attracting a lawsuit? Similar questions trouble government agencies who realise that it is possible, using a standard telephone and Internet, to access Web Sites which contain material that is "as adult" or even "more adult" than anything Exxtasy is broadcasting.

For now, Space TV Systems has a new business of their own to launch and they are best served in getting that new business off the ground by not having to dodge land mines planted to disembowel the Exxtasy people. Space's 7 Mandarin channels, growing to 8 and then 12 within 90 days, all looks like it should attract a sizeable Australian market. We may not applaud their current decision that requires subscribers to pay up front for two years of programming in advance but we can certainly see that it is in their best interest to not have one or two American adult film channels sandwiched in between their Formosa News Channel and their Kuo-Bao variety channel. If nothing else, it was going to be quite difficult explaining away those advertisements urging viewers to call a USA telephone number to *talk* with "The Girls of Exxtasy." Most of the ladies we saw in those commercials had so much crammed into their mouths that "talking" was going to be a very difficult challenge.



## THE YEAR OF SATELLITE EXPLOSION IN THE PACIFIC/ASIA!

**Ku is coming alive on PAS-2 and I177E; the Intelsat "Shuffle" is underway; "Adult" programming has been added and AsiaSat 3 is coming. Stay tuned with SatFACTS!**

- ENTER my 12 MONTH subscription to SatFACTS starting with August 15th issue (rates below)  
 ENTER my 36 MONTH subscription to SatFACTS starting with August 15th issue (rates below)

NAME \_\_\_\_\_

Company (if applicable) \_\_\_\_\_

Mailing address \_\_\_\_\_

Town/city \_\_\_\_\_ Country \_\_\_\_\_

**Amount to send:** 1 year - NZ\$50 (inside New Zealand) / A\$90 (inside Australia) / US\$60 (outside of NZ and Australia) or 3 years - NZ\$120 / A\$210 / US\$150 if by cheque. **VISA** or **Mastercard**? See form below and return with order. Return to: **SatFACTS, PO Box 330, Mangonui, Far North, New Zealand** or if by VISA or Mastercard fax to 64-9-406-1083

**ALL SatFACTS SUBSCRIPTIONS ARE SENT VIA AIRMAIL - WORLD-WIDE!**

### USE THIS FORM ONLY WHEN CHARGING ON VISA/MASTERCARD

Please charge my **VISA/Mastercard** as follows:

- ONE Year of SatFACTS MONTHLY (NZ\$50, A\$90, US\$60)  
 THREE Years of SatFACTS MONTHLY (NZ\$120, A\$210, US\$150)  
 SATELLITE TELEVISION: The Booklet (NZ\$10, A\$12, US\$10)  
 One Year of COOP'S TECHNOLOGY DIGEST (NZ\$125, A\$125, US\$125)

Indicate charge card type:  VISA  Mastercard

Name (as it appears on **VISA / Mastercard**) \_\_\_\_\_

**VISA/Mastercard** Number \_\_\_\_\_ - \_\_\_\_\_ - \_\_\_\_\_ - \_\_\_\_\_

**VISA/Mastercard** expiration date \_\_\_\_\_

**Instructions:** If ordering by mail, return this complete (3-part) card or a copy of same (to **SatFACTS, PO Box 330, Mangonui, Far North, New Zealand**); if order by FAX, send full card as a single sheet to **64-9-406-1083**

### SUPPLEMENTAL MATERIALS from SatFACTS MONTHLY: Order Form

- SATELLITE TELEVISION:** The Booklet. Excellent introduction to home dish ownership for the layman, including major contributions from the father of geostationary satellites - famed science fiction writer *Arthur C. Clarke*. The perfect tool to help the satellite system seller explain home satellite TV to the layman consumer. From SPACE Pacific. NZ\$10 / A\$12 / US\$10, airmail.
- COOP'S TECHNOLOGY DIGEST.** For the really serious enthusiast, investor, business person in satellite television and allied leading edge technologies. Ten issues each year, jam-packed with information you will not find anyplace else. "Coop" routinely culls more than 60 publications world-wide, terribly expensive newsletters, Internet and his hundreds of private contacts to keep you right at the leading edge of technology on the REAL changes underway in telecommunications. Conveniently issued near the **first of the month**, creating an excellent time-line-filler between the mid-month issues of SatFACTS. Now in the 4th year, airmail world-wide. Normally NZ/A/US\$250 per year - for SatFACTS subscribers special **50% discounted** price of NZ/A/US\$125.



## OBSERVER REPORTING FORM - CONTEST ENTRY - Due August 4

- NEW programming sources seen since July 1st: \_\_\_\_\_
- Changes (signal level, transponder, programming content) in pre-existing programming sources since July 1st: \_\_\_\_\_
- OTHER (including changes in your receiving system): \_\_\_\_\_

NOTE: Please use P1 - P5 code when describing signal levels and receiver IF/RF settings.

Your Name \_\_\_\_\_ Is this contest entry? \_\_\_\_\_  
Town/City \_\_\_\_\_  
Make/size dish \_\_\_\_\_ LNB \_\_\_\_\_ Receiver \_\_\_\_\_  
Bonus Word Entry: \_\_\_\_\_ on page \_\_\_\_\_

June BONUS WORD - (CNBC) 626 (Pal) -

MAIL TO: SatFACTS Monthly, PO Box 330, Mangonui, Far North, NZ or fax 64-9-406-1083

### YOU COULD WIN A DYNASAT 300P or PALCOM SL7900RP!

SatFACTS is giving away two (2!) top of the line super receivers - the PALCOM SL7900RP and the DYNASAT 300P - to subscribers between now and February! This is a MONTHLY CONTEST and you must REGISTER with us as a contest entrant. Complete this card to receive the full set of Contest Rules and join the fun. A DYNASAT 300P could well be yours (next receiver to be given away October 5!).

I AM A SUBSCRIBER TO SATFACTS - Please mail to me my SatFACTS Reader Contest Rules!

NAME \_\_\_\_\_  
Company (if applicable) \_\_\_\_\_  
Mailing address \_\_\_\_\_  
Town/City \_\_\_\_\_

Return card to: SatFACTS Monthly, PO Box 330, Mangonui, Far North, New Zealand  
of fax to us at 64-9-406-1083

## MEMBERSHIP IN SPACE?

Choose your level of participation from "Individual" or "Installer / Dealer" to "Cable/SMATV Operator" or "Importer/Manufacturer/ Programmer."

YES - Send details of SPACE membership, to ...

NAME \_\_\_\_\_

Company (if applicable) \_\_\_\_\_

Mailing address \_\_\_\_\_

Town/city \_\_\_\_\_

**SPACE Pacific Ltd.**  
PO Box 30, Mangonui, Far North  
New Zealand  
Fax 64-9-406-1083



# SATELLITE TV TECHNOLOGY CORRESPONDENCE COURSE

The official technician certification course of the **SPACE—Pacific satellite trade association**

**THE SATELLITE TV TECHNOLOGY CORRESPONDENCE COURSE** is a complete home/office study program that has been expressly developed for students and professionals who wish to expand their knowledge and technical skills. The course consists of the *Satellite TVRO Handbook* and *Satellite TV Technology Overview* videotape, supplementary text materials on the latest technical developments in the Asia/Pacific Region, four take-at-home exams, a report card, and a certificate upon course completion. Students are able to proceed at their own pace and receive clarification from the course leader concerning specific course topics or ask questions on related topics.

**THE SATELLITE TV TECHNOLOGY CORRESPONDENCE COURSE** is taught by Mark Long, Founding Publisher of the *World Satellite Almanac*. Each of the four major course exams are mailed to registered students upon receipt of their written request for the exam materials. Completed exams are returned to the course leader for grading and suggestions for further study to clarify those points on each exam which the student may

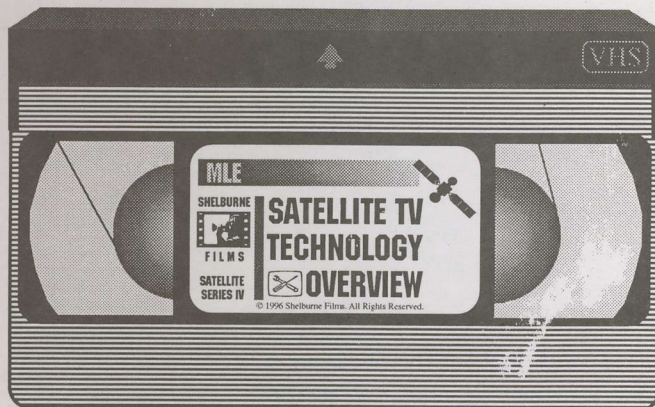

CORRESPONDENCE COURSE VIDEOTAPE (ABOVE): **PART ONE: THE SPACE SEGMENT:** Orbits & Orbital Assignments; Frequencies; Satellite Frequency Bands S/C/Ku/Ka; FSS vs BSS Satellite Frequency Assignments; Satellite Transponders; Satellite Polarization Formats; Satellite Communication Subsystems; and Interpreting Satellite Coverage Maps. **PART TWO: THE EARTH SEGMENT:** Antennas & Feedhorns; LNBs; Receivers and IRDs. **PART THREE: VIDEO AND AUDIO PROCESSING:** Video Standards - NTSC, Pal And Secam; HDTV; Video Encryption; Digital Video Compression; Digitizing Video; MPEG & MPEG DVB; MPEG Compression Techniques; MPEG Data Rates; Transmitting MPEG Via Satellite. **PART FOUR: INSTALLING SATELLITE RECEIVING SYSTEMS:** Antenna & Feedhorn Alignment; Installing Digital Receiving Systems. 60 minutes, PAL-VHS.

not have fully mastered. Upon successful completion of the four major exams, each student will be awarded a certificate of course completion.

## THE SATELLITE TVRO HANDBOOK

written & compiled by Mark Long

Founding Publisher of The *WORLD SATELLITE ALMANAC*

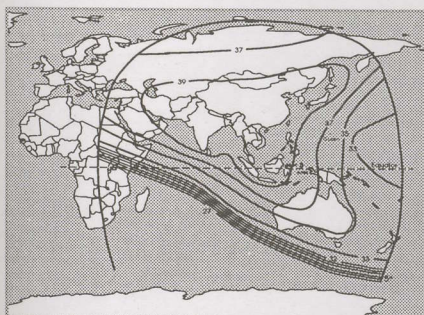

- ✓ INTERPRETING SATELLITE FOOTPRINTS
- ✓ SATELLITE FREQUENCY ASSIGNMENTS
- ✓ VIDEO & HDTV STANDARDS
- ✓ MPEG DIGITAL COMPRESSION
- ✓ TVRO SYSTEM DESIGN
- ✓ INSTALLATION PROCEDURES
- ✓ TRACKING INCLINED ORBIT SATELLITES
- ✓ SMATV SYSTEM OVERVIEW
- ✓ SOLAR & RAIN OUTAGES
- ✓ TERMINOLOGY GLOSSARY

THE OFFICIAL  
TECHNICIAN  
CERTIFICATION  
TEXTBOOK OF  
**SPACE Pacific**  
Satellite  
Program  
Access  
Committee  
The trade association of private satellite-direct systems in the Pacific Ocean Region

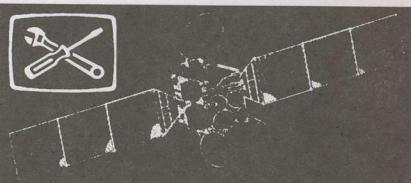

Available from **SPACE—Pacific** for NZ\$ 650, A\$600, or US\$ 394. **THE SATELLITE TV TECHNOLOGY CORRESPONDENCE COURSE** includes the basic course textbook, a one-hour course videotape, supplementary text and graphic materials, exams, a report card, a certificate upon successful completion of the course and all shipping and handling fees. Contact: **SPACE—Pacific**, PO Box 30, Mangonui, Far North, New Zealand. Fax: 64-9-406-1083

CORRESPONDENCE COURSE TEXTBOOK (Left): A comprehensive introduction to all aspects of satellite video and audio technology covering basic satellite terminology and the interpretation of satellite coverage maps; satellite subsystem overview; satellite telecommunication frequency assignments; video transmission and encryption standards, digital video compression and HDTV; international satellite earth station component guide; how to install satellite TV receive only (TVRO) systems, modified polar mount alignment; inclined orbit satellite tracking guide, SMATV system design; the effects of solar outages and rain fades on satellite system design, and a complete lexicon of satellite terminology. The official technician certification course textbook of **SPACE Pacific**. 212 pages illustrated.



# UNIDEN SATELLITE TELEVISION

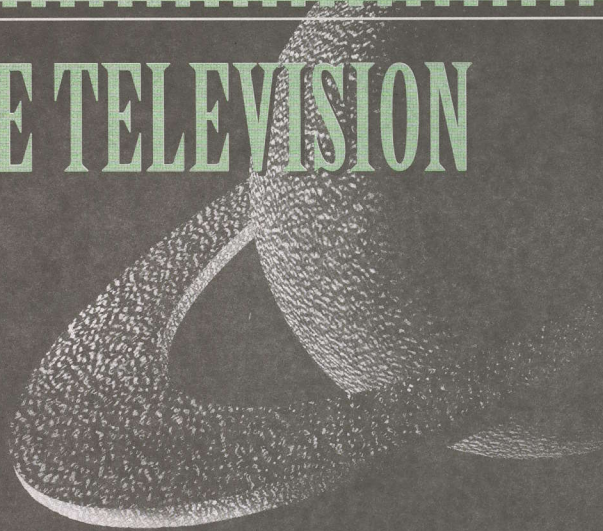

## *JUST IMAGINE...*

*Over thirty channels of free-to-air television from around the globe available throughout New Zealand. even in areas where present free-to-air or paid channels don't reach.*

*THIS IS NOT A DREAM, It's a reality. And it's available to your customers right now, with equipment costs that are probably a lot less than you would expect.*

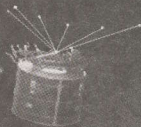

*Uniden are about to launch their Satellite Television Package to dealers throughout New Zealand.*

*If you would like to find out how to profit from satellite television in New Zealand give Uniden a call.*

*After all, Uniden is one of the world leaders in satellite television technology.*

## UNIDEN SATELLITE TELEVISION

*Putting You Face To Face With  
A World of Entertainment*

**uniden®**

*a Clear Signal of What's Ahead*

*For more information Phone 0-9-273 8383 or Fax 0-9-274 0009*

*Uniden® is a registered trademark of the Uniden Corporation of Japan Ltd and is represented in New Zealand by Uniden (NZ) Ltd.*