

13-02-97 12 Noon

Bob Cooper's

FEBRUARY 15 1997

SatFACTS

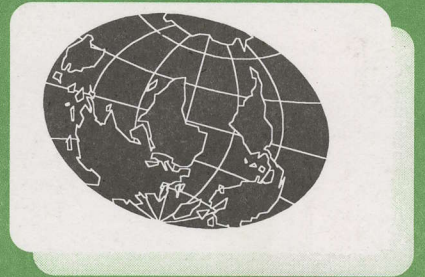

MONTHLY

Reporting on "The World" of satellite television in the Pacific Ocean Region

IN THIS ISSUE

**SAFE and SANE
ANTENNA
MOUNTS**

**SPRSCS '97
UNTANGLES FEW
MYSTERIES**

**'PERFECT' MPEG
RECEIVER
NOT HERE YET**

- ✓ Latest Programmer News
- ✓ Latest Hardware News
- ✓ Latest SPACE Pacific Reports
- ✓ Cable TV Connection

Vol. 3 ♦ No. 30

Price Per Copy:
NZ\$8/A\$9/US\$5

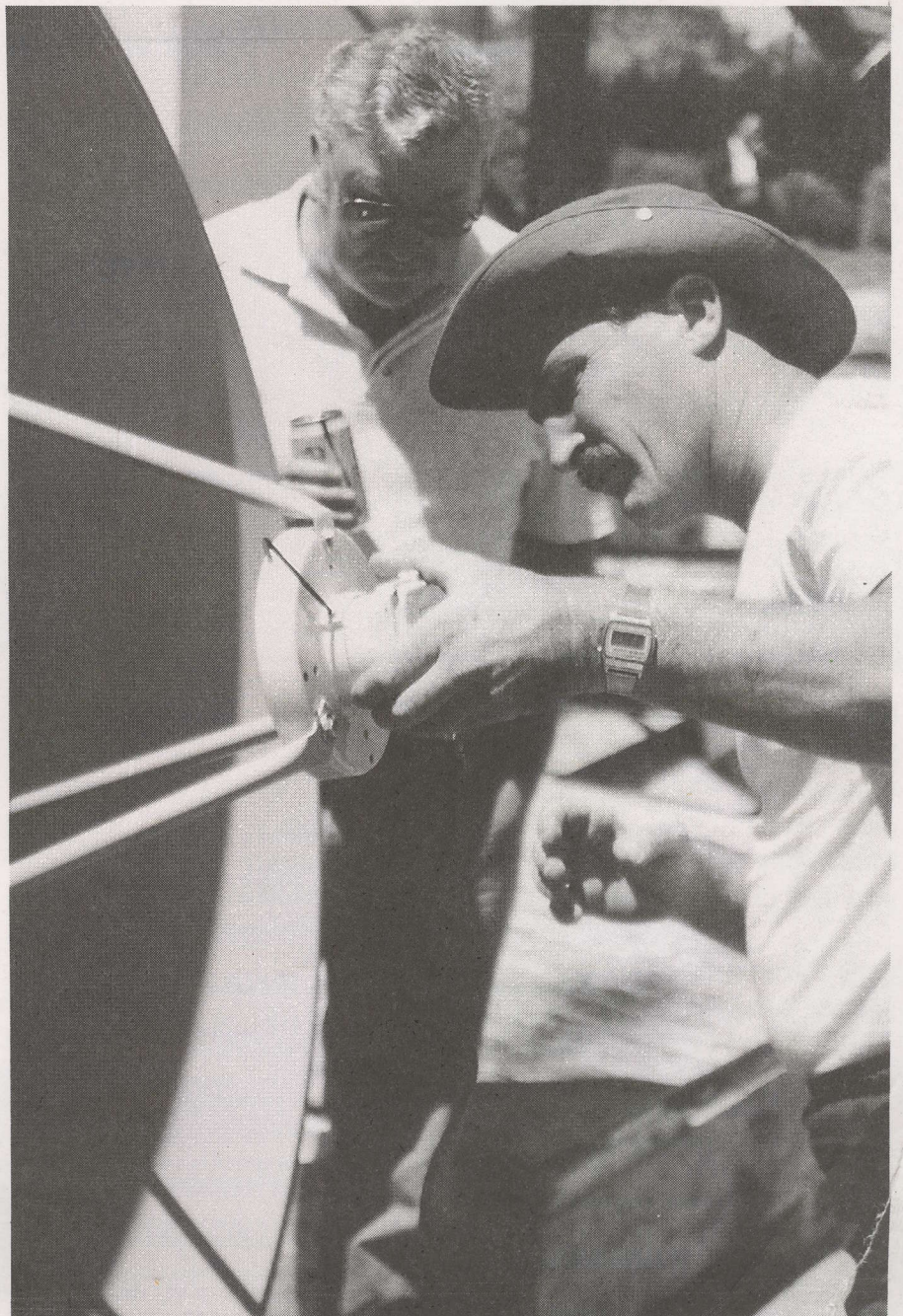

Paraclipse[®]

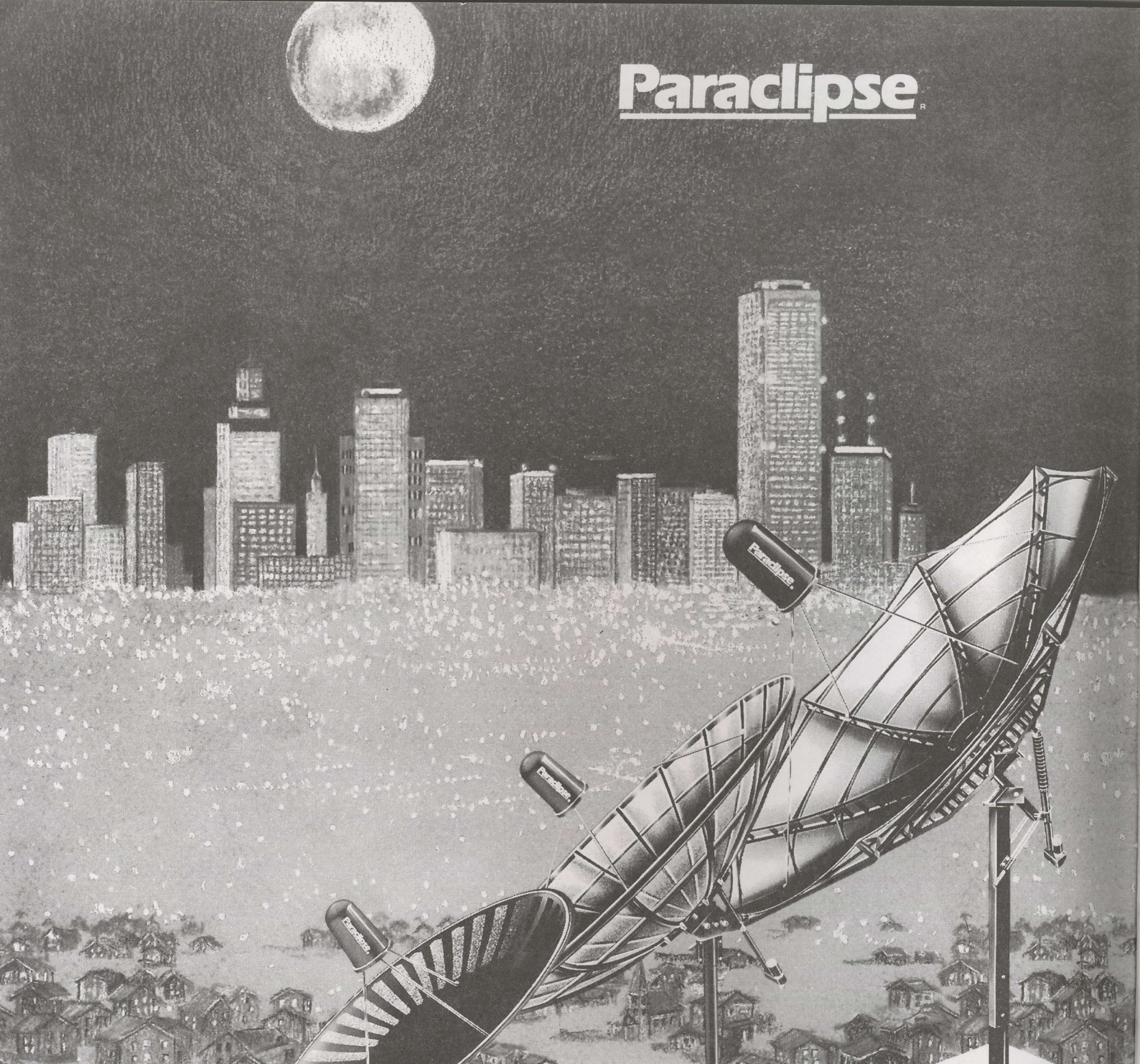

When quality, strength, and accuracy are your main requirements, **Paraclipse** antennas are your first choice.

Only **Paraclipse** offers such variety; four distinctly different series:

- the Truss-Ribbed Classic,
- the Courier Deliverable Eclipse,
- the Stretch Formed Hydro,
- the Commercial Patriot.

Every **Paraclipse** model sets the industry standard in its class, worldwide.

HYDRO
SERIES

ECLIPSE
SERIES

CLASSIC
SERIES

Distributed in New Zealand by
Bay Satellite TV Ltd. PO Box 14050 Hastings
Tel: 64-6-878-9081 Fax: 64-6-878-5994

Paraclipse[®]
HIGH PERFORMANCE ANTENNAS

Paraclipse Inc.
2271 29th Avenue East, Columbus, Nebraska USA 68601
Telephone: (402) 563-3625 FAX: (402) 564-2109

★ **MADE IN AMERICA**

SatFACTS MONTHLY

is published 12 times each year (on or about the 15th of each month) by Far North Cablevision, Ltd. This publication is dedicated to the premise that as we enter the 21st century, ancient 20th century notions concerning borders and boundaries no long define a person's horizon. In the air, all around you, are microwave signals carrying messages of entertainment, information and education. These messages are available to anyone willing to install the appropriate receiving equipment and, where applicable, pay a monthly or annual fee to receive the content of these messages in the privacy of their own home.

Editor/Publisher
Robert B. Cooper (ZL4AAA)
Office Manager
Gay V. Cooper (ZL1GG)

Reaching SatFACTS

Tel: 64-9-406-0651
Fax: 64-9-406-1083
Mail: PO Box 330
Mangonui, Far North
New Zealand

Subscription Rates

Within NZ: \$50 p/ly
Australia: AV-COMM Pty Ltd, PO Box
225, Balgowlah, NSW 2093
61-2-9949-7417
Elsewhere: US\$50 p/ly
All copies sent via airmail fast post
world-wide

ERRATA

SatFACTS Copyright 1997 by Robert
B. Cooper; any form of copying is a
violation of our international
copyrights. Advertising rate sheet
available upon request.

COOP'S COMMENT

Of all of the people I met during SPRSCS '97 in Auckland, two were outstanding. One is Jim Hodgetts of TV5 Paris and the other is Giovanni De Luca of RAI International. We arranged interviews with New Zealand 'National Radio' for the pair just on the strength of Giovanni's name; the show hostess said, "I just want to say his name on the air - what a magnificent sound it will make in radio sets all over New Zealand!" Little did she appreciate that translated his name becomes George Light.

Giovanni is the newly appointed "Asia Area Manager" for RAI (that apparently includes the Pacific as well, or, Giovanni turned 'right' in Tokyo when he should have turned

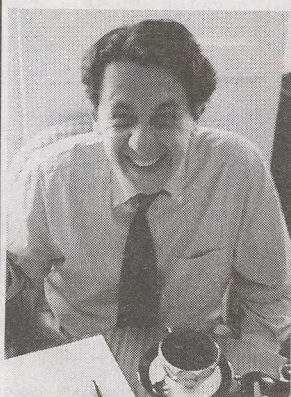

RAI's Giovanni De Luca

left!). We sat for a couple of hours - Giovanni, Jim Hodgetts and I - in a quiet club in downtown Auckland to discuss what is ahead for their respective services and the European Bouquet. I learned, for example, that if the Bouquet is able to persuade AsiaSat they should be on As3 (105.5E), they would like to move there. That will certainly help us in New Zealand and open up new French language areas for TV5 and MCM in the central Pacific. I also learned about squabbles within the EBB (sorry - I agreed it was 'off the record' and so it shall remain), why the Dutch (radio) is not included, and heard a long list of 'dirty tricks' practised by a certain media mogul based in London who has done everything he can to keep EBB from surviving. (Also at SPRSCS '97 I met Barbara Lodge, now with TVNZ in Auckland, who spun an intriguing tale of how she, a lady friend and a gentleman friend created what is now BSKyB; a story I shall save for a later date. She is another person who dislikes a certain London based media baron.)

Giovanni De Luca (say it out loud - let the Giovanni roll off your tongue slowly - it is infectious) believes RAI International can turn into a totally new kind of television service. He sees Asia and the Pacific as a separate market, one that deserves its own programmes created at RAI just for this region of the world. In the near term, there will be daily English language newscasts dealing with the Asia-Pacific region, new game and drama shows dubbed or redone in English and even sport in English. Fanta Sport is too complicated to explain in the limited space here but I'll give you this clue - it involves betting (as in wagering), winning money (or losing money!), the biggest names in sport in the world, and an interactive way that viewers participate. May 1st is the hoped for on-air-date.

I give Giovanni and his Italian compatriots a 50-50 chance of making this innovative new programming fly. Their concepts are sound (if somewhat unproven) and there is an element of financial risk here. But the rewards are quite enticing; Giovanni (slowly - off your tongue) left Auckland for a whirlwind visit throughout China to try to sell the Chinese on allowing RAI International into their SMATV and terrestrial circuits. The approach is fresh, and totally different to his bouquet competition. YES - they wish to export Italian culture, art, music and industry. NO - they don't think it has to be done with reruns of Italian terrestrial TV.

My good friend Jim Hodgetts (who travels with a Nokia 9500 S [V1.63] packed between layers of underwear in his suitcase - just in case he has the opportunity to show off the bouquet during a stop over) listened patiently to Giovanni's plans. I was not certain he had heard them before. Jim, an Irish origin French citizen with one of those amazing accents (marrying French to Irish and English is a treat), was clearly impressed even if he could not bring himself to say so. TV5, by the way, is second only to CNN in world-wide audience - a measurement statistic I found an eye opener. "The (European) Bouquet is a living, breathing animal," he noted. "What we see today is ever changing." That it is.



February 15, 1997

In Volume 3 ♦ Number 30

SAFE and SANE Antenna Mounts (Eric Fien) -p. 6
SHOW of SHOWS - Serious Business -p. 11
BEST and WORST of MPEG at SPRSCS -p. 15

Departments

Programmer/Programming Update -p.2; Hardware/Equipment Update -p. 4
SPACE Notes: Family Television Network -p. 20;
The Cable Connection / The Sky Proposal -p. 22;
SatFACTS Orbit Watch -p. 24; MPEG-2 Tuning Parameters -p. 26;
With The Observers -p. 28; At Sign-Off (Cheap Systems) -p. 32
February Reporting Form -p. 33; Contest Rules Application -p. 34

-ON THE COVER-

Alan Meharry adjusts feed on 1.5m Paraclipse 'Hydro' dish for C-band reception attempt on AsiaSat 2 during SPRSCS '97. The less than 4 degree look angle to As2 has not changed in the last 12 months since 1996 attendees were amazed at small dish reception at such low look angles. In all honesty - the pictures were not great but moving the dish to Palapa C2 produced P5 images from CFI (see p. 32).

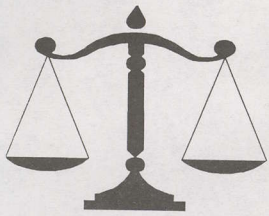
**MAD As Hell**

"Your magazine is pro business operators. Well, this is from a hobbyist. "Sue the bastards?" (brochure promoting recent SPRSCS) - I could not agree more! Once again we lose another satellite channel to scrambling: EMTV. Since some 14 years ago we've lost so many good channels to scrambling. Thanks to hotels, motels and now cable operators both in New Zealand and Australia. Unlawfully distributing satellite signals like EM TV, NHK, BBC World (to name a few) is the cause of the scrambling - thanks a bloody lot! Satellite TV is a hobby of mine and I don't make any money from it, unlike you creatures. Yes, I wish the broadcasters would pick the lot of you out of the wood work, sue you, and then leave you in the summer sun to dry up and blow away! I wish you a sun outage everyday."

Paul Burton (EM TV fan), N. Auckland, NZ

Come-on Paul - when you have something on your mind, spit it out - don't beat around the bush!

LOOKING For Holy Grail

"I am a subscriber to SatFACTS and Coop's Technology Digest and like your reports very much. My company installs here in Thailand systems for the European Bouquet for ex-pat residents and we are having difficulties locating suitable receivers. Can you give me information concerning the DigiSkan SK888 and tell me will it do the EBB OK for my customers?"

Christoph Hamann, SatCARE (Phuket), Thailand

For a consumer only interested in pushing a button and watching television, the SK888 is ideal. Our testing reveals it to be totally consumer friendly and moreover you will like it as an installer - no complicated software set-ups to hassle you.

PACE FTA MPEG Receiver

"We expect to have details shortly for our new free to air receiver intended for use in the Asia & Pacific market and will be in touch. We find SatFACTS very resourceful and comprehensive."

Magdalene Chan, Asia Marketing Communications Mgr.
Pace Micro Technology (Asia) Ltd.

Good Show

"Congratulations on yet another good show. I was most certainly happy with the results from SPRSCS '97."

Albert Voorthuis, ANTEC Asia Pacific

For those who missed this year's show, a library of show videotapes shot by a camera crew from The Family Television Network is available at quite reasonable pricing; see p. 10 this issue. Albert "lost" (misplaced, forgot, did not remember to take down ...) his ANTEC booth banner. Will the pervert who ran off with it as a wall hanging show collectable please return it to SF in an unmarked package so we can return it to Albert? There is a reward for being a good Samaritan; purgatory awaits you if you consider it too good to return!

**PROGRAMMER
PROGRAMMING
PROMOTION****UPDATE****FEBRUARY 15, 1997**

MEASAT 2 (148E) claims to be negotiating with two firms interested in reaching eastern Australia on C-band. The satellite has 6 transponders capable of "coming south"; they expect test transmissions during next 45 days.

China-Bouquet (CB) composed of 9 SCPC uplinks within As2 transponders 3B and 6B may be significant leading edge of terrestrial digital. By feeding low Msym rate services to satellite, it is technically possible to exit the IRD in MPEG format (i.e., not turning it back to an analogue display), connect that to a VHF, UHF or MMDS transmitter, and then go through the air to individual home site receivers still in the digital format. Result? China would become first significant user of terrestrially linked MPEG and individual homes would have some low-cost terrestrial-frequency IRD to receive signal(s). It would be strange indeed if China quietly took the lead in the terrestrial MPEG evolution while more technically advanced countries (USA, UK et al) are still arguing about who will do it and how.

Feedback power. IN SF#29 we urged the industry to "flood RAI International" with faxes in protest of their convoluted transmission schedule that saw down time (test card) just as the Pacific-Asian region entered "prime viewing" hours (i.e., after 6pm local). By February 1 RAI was turning on AsiaSat 2 feed at 1600 UTC and running to 0900 UTC - far better for us. Keep those cards and letters flying!

REBAR (Taiwan) MPEG service on 1410VT (AS2) identifies programmes within bouquet as "U1," "U2," "U3" and "Channel 4." Years ago when Taiwan had only three official TV channels (TTV, CTS and CTV) cable operators would call their early-days tape created bootleg programming "Channel 4." Thus the Channel 4 "logo" has special meaning to cable operators and viewers - a swashbuckling return to the piracy days of old!

STAR TV is adding ten channels of its Asia based programming to the DTH digital package from Orbit Communications in the Middle East. Included: Channel [V], Star Movies, Star Sports, Sky News, CNBC, NBC Asia, Zee Cinema, and Filipino movie channel Viva.

NBC & CNBC have a fax-callback service if you require updates on programming information. Dial + +852-172-75-555 and then select from the following: CNBC weekly schedule (87701), NBC weekly schedule (87703). Your selection made, they will "fax you back immediately" (they say) with the requested document.

Galaxy policy concerning "subsidised" dish installs (A\$199 for install, up to 90 cm in size) is creating world of "have nots"; people who live just beyond regions where 90 cm or smaller will work and require larger dishes. A 1.2m install jumps to A\$1,700 for a 'purchased' system, plus \$600 per year for programming package. Unhappy Australians are 'arranging' installs at family, friendly homes inside of 90 cm areas, managing their own (1.2 or whatever) dish and as soon as Galaxy installer leaves, hauling everything but the dish off to their own home located beyond normal 90 cm install region. The sneaky ones are asking friendlies to order second Galaxy decoder (\$30 per month) and putting in their own antenna/LNBs - spiriting the "extra" decoder off to their homes. The really sneaky simply remove the smart card from the friendly 2nd receiver and plug it into their own SK888, or PanaSat. Galaxy got themselves into this mess.

Sky (NZ) has a plan - to extend beyond New Zealand to spots such as Cooks.

Third time is the charm. G & G Imports (NT, Australia) source for Nokia V1.63 9500 S receivers - the correct telephone and fax number is 61-8-8941-8860. We got it wrong in December, further messed up in January!



The 'Missing' Antec banner

OPERATING In The Dark?

"Please send as soon as possible two copies of the latest SatFACTS; the most recent listing we have of satellites and transponders in the Pacific is World Satellite Directory dated 1994. We operate cable in islands throughout the western Pacific and need to beef up our channel carriage."

Marianas Cablevision, Saipan

1994? Egads - dark ages ago!

Welcome to the Satellite World

"I have just purchased the following equipment: KTI 3.7m mesh with actuator, mount; Echostar LT-530 receiver, Chaparral C/Ku feed with C/W BKUHO48 Ku LNB and Echostar EA025 C-band LNB. I already had a DAST DR903N C/Ku manual receiver, Gardiner 35K C-band LNB and unknown brand C-band feed horn. In my area, is it practical to use Ku-band? Will a better signal be obtained if I only use the C-band feedhorn? Which of the two C-band LNBs would work best?"

John Stewart, Invercargill, NZ

Ku-band is practical but the Chaparral C + Ku feed extracts a penalty for providing both bands with a single feed; reduced performance (by up to 2 dB which is a bunch) typically on C-band. So you have a choice - convenience of one dish, one feed, or best performance on C only. We suggest you try it both ways and form a conclusion which suits you best. The Echostar 25K LNB, in theory, will produce better quality reception than the (older) 35K unit. The numbers describe LNB noise contribution and the smaller the number, the better off you will be.

FAREWELL Is Not Good-Bye

"Unfortunately I did not have the opportunity to say farewell to Coop, Gay and Mark Long at the Barrycourt on January 24. I wanted to congratulate all involved on the success of this year's SPRSCS in Auckland and to convey my appreciation for all of the work and effort to organise and co-ordinate this event. Indirectly we will keep in touch "through SatFACTS" and I hope we will have the opportunity to meet again in the future!"

Reiner Petrou, Operations Manager

Tolec Electronics Pty Ltd, Lae, PNG

We were especially pleased at the turn out from "the islands" this year - less so with attendance from South Island (NZ). Imagine - as many from PNG as from South Island! Shame on the Kiwis who stayed home and missed their annual national show.

BAD Audio

"Am I imagining the muddy, slurred-sss' audio on EWTN? Can't they fix this?"

T. Axley, Warkworth, NZ

Worst audio in the Pacific award goes to EWTN, with TV Shopping Network a close second. Don't these people ever listen to themselves on downlink?

HARDWARE EQUIPMENT PARTS

UPDATE

FEBRUARY 15, 1997

American TDRSS (data and relay) satellite presently located at 84.75E may provide one or more C-band transponders for us to Thailand military. TDRSS needs a more "secure" geostationary orbit spot and Thai's are willing to offer one in exchange for use of spare transponder capacity.

Intelsat 801, long delayed, now scheduled for February 25th Ariane flight, heading to 174E. This is first step in yearlong musical satellite effort that will see 701 (now 174E) going to 180E, 511 going to Indian Ocean, 803 going to 177E in place of 703.

JCsat -5 will now launch to 150E as early as 6 November (1997). On board the Hughes 601, 32 Ku transponders designed to reach "Japan, Asia-Pacific and Hawaii."

PAS-8, now scheduled for "early 1998" launch by a CCIS Proton vehicle, is to park at 166E (2 west of PAS-2) and will have 24C and 24 Ku transponders on board.

AsiaSat is claiming a (US)\$58 million insurance loss on As2, blaming Chinese Long March rocket for "bouncing" the satellite during launch resulting in significant power loss for 9 of the Ku-band transponders on board. AsiaSat says the "bouncing" knocked the Ku antennas out of alignment resulting in on ground power losses approaching 13 dB. As a result of the power loss, STAR TV cancelled its lease for 3 of the As2 Ku-band transponders.

DIGITAL TV Analyser has been announced by PROMAX. ProLink 7 is a satellite and TV signal level meter (based upon the popular MC 944) with digital (QPSK, QAM, OFDM or QPSK-Data) detection and measurement circuits. On-screen display tells you status ("locked") and bit error rate (BER). Data sheets from +-343-338-1126.

Chinese launch of 9 regional SCPC MPEG caught MPEG suppliers totally off guard. Philips built uplink hardware, has small contract to provide first receivers (Philips model DVS-3950/11) to SMATV and terrestrial rebroadcast sites. Receivers have fixed Msym and FEC (see p. 26) as deterrent to Chinese users "dialling around" to find other MPEG DVB signals on their own. By end of January virtually every MPEG receiver builder in world had sent task force into China to learn just how big this order might become. Nobody - nobody - had any advance warning on this and even Philips has to date not released a press story detailing their deal. Most strange foodstuff indeed.

Panasat 630, "totally unlike the 520 and far easier to program and use," according to early testers is suddenly available through Antares Satellite Products (Strathpine, Qld tel/fax 61-7-3205-7574). Unit does not do Msym rates below 15(000) as it comes out of the box but Europeans who have tried the 630 unit claim there is software that makes this possible; sourcing it is the challenge. Pricing for 630 is "in range of A\$750."

Pacific Satellite International Ltd. (HK tel +-852-2898-1382, fax +-852-2558-0406) has a non-brand-name DVB Compliant MPEG receiver which they claim does Msym rates below and above 15.000, price US\$710 in quantity. Unit is consumer design, no front panel display using on screen menu and IR remote for control. Contact Albert Laurel.

Long Time Technology, a Taiwan firm, is offering three MPEG DVB receivers to dealers in Asia; models 9500, 9600 and 9700. Last is rack mount cable headend intended, first two are consumer units. In Beijing, according to SF reader, model 9500 is US\$1,000 each but there is 100% duty on imports (i.e., divide by 2). Unit works fine on EBB, but apparently different model versions cover only portions of Msym between 4 and 30 (i.e., none covers it all). The fun continues.

ADL[®]

BECAUSE PERFORMANCE IS ALWAYS YOUR FIRST PRIORITY

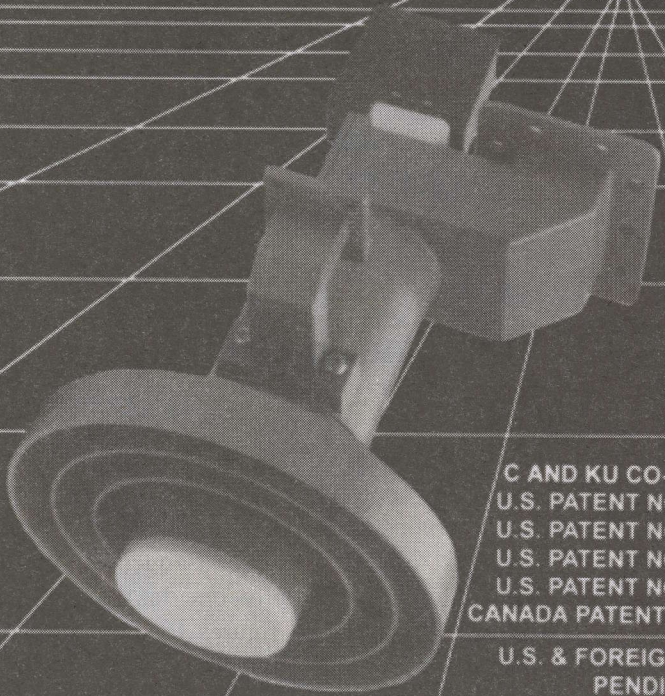

**RP3-CKU/ International
Adjustable Scalar Ring Feed
with Extended C Band**

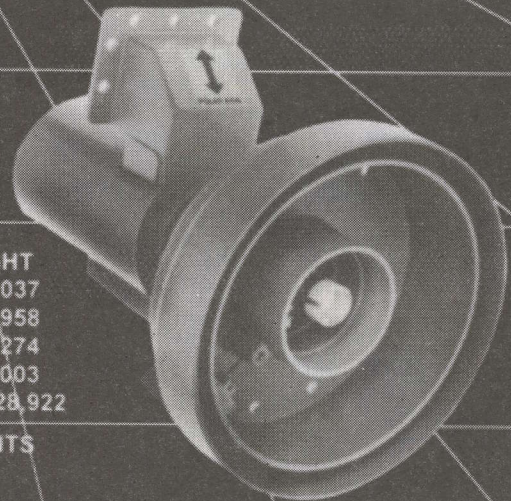

RPI-CKU Feed

C AND KU CO-BORSIGHT
U.S. PATENT NO. 4,903,037
U.S. PATENT NO. 5,066,958
U.S. PATENT NO. 5,107,274
U.S. PATENT NO. 5,255,003
CANADA PATENT NO. 1,328,922

U.S. & FOREIGN PATENTS
PENDING

ADL HYBRID MODING CIRCULAR POLARIZED INTELSAT FEEDS WITH EXCLUSIVE T.I. REJECTION



RP1-CP400



CP-300



CPOR-100

- C BAND LINEAR & CIRCULAR • C/KU LINEAR & CIRCULAR • KU 12 GHz FEEDS
- INTELSAT 4 GHz CIRCULAR • ARABSAT S BAND FEEDS

OPTIONAL: CO-BORSIGHT S BAND

2216 AGATE COURT, UNIT B, SIMI VALLEY, CALIFORNIA 93065 • (805) 526-5249 • FAX (805) 584-0634

Perhaps Your Problem is YOU!

SANE & SENSIBLE INSTALLATION TECHNIQUES FOR COMMERCIAL INSTALLATIONS

Let me begin by defining what I mean by sane and sensible and then explain the difference between a commercial installation and a home system install.

For any satellite system installation a fair degree of sanity is an absolute must. Although there are a fair number of satellite dish systems now operating in Australia and New Zealand, these are still not commonplace and thus there is impact - not always good - on the general public and the authorities. Dishes are still something of a novelty and therefore are usually treated with some suspicion and at least a small measure of trepidation. To balance this "negative" the installer needs to not only install the dish in a workmanlike manner but it also must be, to the best of your ability and imagination, installed so that it blends in with the general scenery rather than being blatantly obvious (and to many, an unwanted eyesore). In some locations the installer can afford the luxury of carefully considering multiple dish locations, allowing the customer or authorities to "select" the spot that is "least objectionable." In other real-world situations, there is only one small area or even a single spot where the dish can be mounted to obtain an unobstructed view of the satellite. Even in this situation, there are steps the installer can take to reduce the visual impact of the installation - match painting the antenna and its mount is one form of "camouflage."

For an installation to be sensible, I understand that to mean the selection of the site, the antennas type and its mounting should be adequate for the purpose in a technical sense - neither too large nor too small in size, placed to provide an unobstructed view and without undue mechanical complexity in the mounting arrangement. Many of the factors here are related very closely to the sanity aspects - and they are highly correlated. However, this is where alternatives to the initial plan come into play - variations you can make in the actual installation to improve the general perception of the installation being a sensible approach.

ABOUT: The Author & This Paper

SPACE member Eric Fien presented this paper at the just concluded SPRSCS '97 event. Fien's firm, Commercial Satellite Systems Installers Australia, operates out of Mount Kembla (NSW) and includes an impressive array of well known firms in its client roster. Contact at (fax) +61-42-72-4033 or e-mail CSSIA@OZEMAIL.COM.AU.

In general terms, commercial installations have a number of significant differences from domestic installations as well as a small number of similarities. I will briefly digress to look at the picture from the basic roots of every installation.

For any satellite system the primary objective is to provide a reliable satellite delivered signal to the end user, whether this is a single customer or a group of customers. To do this, you must be able to direct the chosen antenna with considerable precision directly at the satellite required and moreover maintain that antenna bearing even under abnormal climatic conditions. Every antenna system will, of course, have its "instability point" - a wind force level beyond which the antenna, no matter how installed, will move. It should be a part of your planning that if this happens, the antenna will either re-find (on its own) the correct heading, or, can be re-pointed with a minimum of time and effort. In a domestic installation, the momentary loss of signal is of no great consequence. In a commercial installation, especially one taking a high speed data stream of facts and figures for commercial purposes, even a brief loss can have huge dollar consequences. For this reason alone commercial installations employ very much more rigid structures that forcibly hold the antenna in its location with far greater certainty at much higher wind loading. This challenge is magnified by the widespread adoption of compression systems (MPEG-2 or variants thereof) where the data stream has almost no redundant data.

The "normal" 89mm diameter pole supporting an antenna 2 to 3 metres above ground is quite a rare sight (or, it should be). I have a simple model that will perhaps demonstrate the reason why this is so. When a sudden gust of wind strikes an antenna supported on a pole which is in turn secured only at one end (the concrete block in the ground or the base plate that has been welded on), the (mounting pipe) structure bends quite significantly. How significantly, you ask. For a 2 metre high mast a momentary displacement of just 70mm bends the mast 2.25 degrees at the top, and with it the entire antenna. (In the real world, the antenna is also bending on its mounting frame simultaneously although if the antenna frame is well designed, the amount of antenna flexing will be smaller than the bending of the mast.)

To create a 70mm movement the wind gust on a 3 square metre antenna (which is 1.8m diameter) need only be 55 kph. At ground level that may seem like

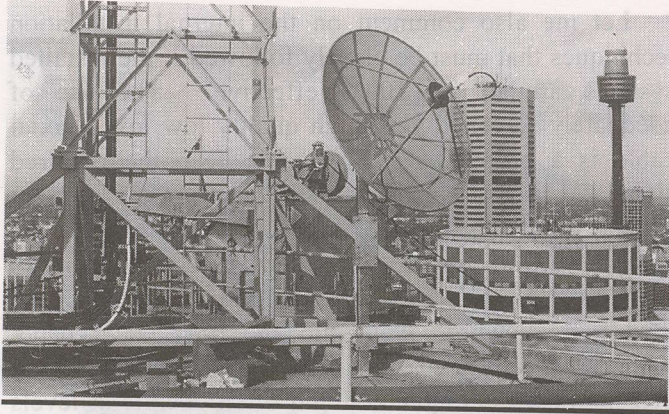

quite a gust (although not rare). However, a commercial installation on top of a 45 storey building is frequently subjected to winds of this force and more. Now the significance of the 70mm bend is this: The antenna's front beamwidth as defined by its -3dB points is usually in the range of 1.5 to 2.5 degrees. A sudden (wind gust) loss of 50% of the signal will pull most digital receivers down to or below the nominal threshold and the reception service ceases. Worst still, if the antenna moves under wind pressure by that 1.5 to 2.5 degrees, the chance the antenna will capture from an adjacent satellite is quite large. (For low elevation satellites, a vertical movement of the dish translates to a near tracking of the arc.)

To go the next step - at and near ground level the velocity change in wind front is significantly affected by the buildings, trees and other structures in the wind path. This is not dissimilar to the ocean waves rolling towards shore: In the vicinity of the shore line the waves are diffracted, reflected and generally slowed down by the drag created by the structures with which it they are in contact. At 180 metres (45 storeys above ground), the top of a high rise building is more akin to a mooring post jutting up out of the ocean. The waves strike it sharply with almost full force. Even if there are numerous posts there is only a minimal effect on the steepness of the wave front. A precisely similar situation applies with high rise buildings unless another similar height building blocks the wind path quite close to the building in question. By observation, a 50 kph gust measured near ground level is often in excess of 100 kph 180 metres above ground. Such winds are not uncommon in eastern Australia during most seasons.

For these reasons alone a pole mount is almost always a bad choice in a high rise commercial environment. The position can easily be improved, not by increasing the pole size or wall thickness, nor by welding the bottom end to an even larger bottom end. The solution is to diagonal brace in three or four directions as close to the actual point of antenna mount (to the support pipe) as possible. In theory, even 6mm high tensile cable secured to the mast and to the "ground" will provide significantly stronger rigidity to dampen if not eliminate the major deflection of the mast. However, once you have such diagonal supports the entire

installation becomes significantly "larger" and more susceptible to accidental or permanent damage. And, it becomes more difficult to camouflage.

There is an alternate approach, one which my firm prefers out of experience. By using three triangular fabricated "frames" which are bolted to the mast section, the frames are secured at the "ground" to effect bracing. The reasons for this learned approach are: Weight, rigidity, cost, and portability. Many an installer has agreed to place a dish on a commercial building roof and then discovered he may have to fly it in! Almost without exception a high rise lift stops two or three floors below the rooftop and then to navigate to the actual roof one finds a series of narrow passage ways, vertical ladders and often a trap door at the top. Getting a fully assembled antenna (even a 1.8m) up the side of a high rise as an alternative can sometimes be arranged by using the Building Maintenance Unit (BMU), but at considerable cost, complexity and then only when the BMU can be spared from normal building duties. The luxury of helicopter delivery is usually beyond the limits of acceptable cost and typically beset with other challenges (waiting for calm winds, presence of other pre-existing masts and hardware on the roof, CAA clearance) which are difficult to overcome.

The very nature of a commercial installation normally confines the antenna system to a single satellite so that all of the usual problems associated with "tracking" the Clarke Orbit Belt are eliminated. An azimuth / elevation mount (so-called az-el) is used in 99% of all commercial installations. This does not necessarily simplify the mechanics of the installation as most az-el mounts have been designed for use where relatively high look angles are found. A surprising number of az-el mounts were not designed to function below 20 degrees (i.e., you can't get there - from here!) and must be shop modified before the installation begins. Polar tracking? Absolutely not! The last thing you need in a high wind location is a "tracking arm" on an actuator tilted over 70 degrees to find a low look angle satellite.

The next significant difference between commercial and domestic installations has more to do with the nature of the signal than the actual propagation. It is often the case that the required signal is closely attended by signals on (a) adjacent transponders but of opposite polarity (same satellite), (b) adjacent transponders of the same polarity (same satellite), (c) the same (or very nearly so) transponders on adjacent satellites (same or different polarity). All of these combinations occur in the Pacific/Asia region. The degree of interference and the complexity to which the installer must go to provide clean signal is determined on a case by case basis. The presence of (notably Russian) inclined orbit satellites is the most significant difficulty. Equally, it is important to

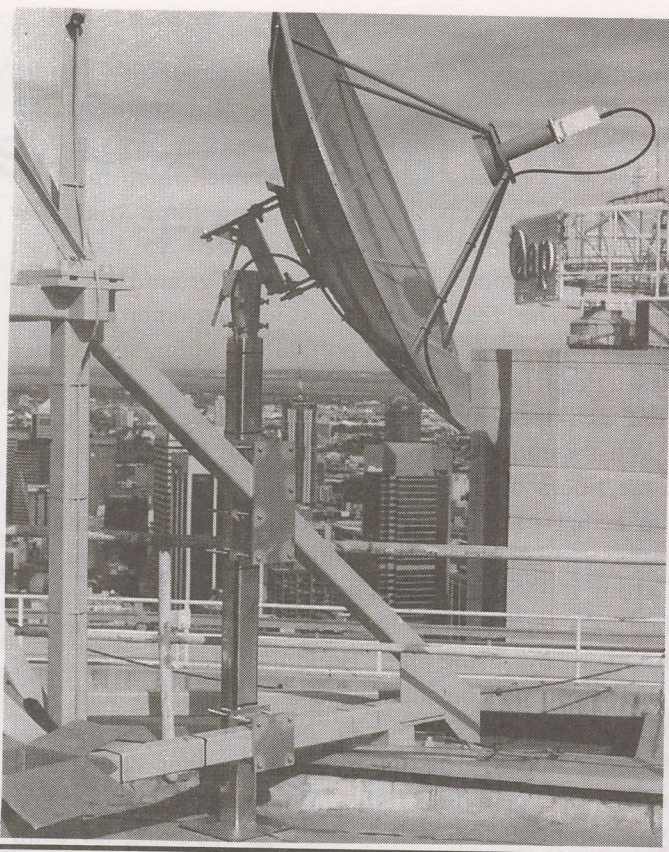

be aware of proposed transponder allocations for both the desired satellite and those to be future located on either side. This information can be extremely difficult to locate and subject to frequent change. In the worst case, you will be surprised and you will perhaps be required to return to the site sometime after the installation to take corrective measures to cope with new transponders that have come on line.

The biggest difference in the characteristics of a commercial installation is the down stream signal processing. The majority of commercial systems use encoded as well as redundant and spread spectrum techniques to safeguard their valuable commodity - the signal content. The value of the end product generally means that the relatively high cost of highly sophisticated and secure delivery systems and receivers/decoders is easy enough to justify. However, this creates a new burden for the installer - signals must be "squeaky clean" at the antenna site as well as through the cable delivery system to the actual IRD/processors. I have noted in this publication and elsewhere comments concerning multi-powered splitters and taps that power pass on all ports. I believe such devices can be used successfully provided they are selected on quality, not price, basis.

I have a personal preference for the main amplifier and tap distribution scheme, but some of our customers have indicated a preference for multiple splitter + line amplifier installations. In each instances, regardless of system design choice, all unused ports must be terminated - an absolute must!

Let me also comment on the internal installation techniques that must be closely followed if the installed systems are to be 100% effective. The use of adequately screened very high quality low loss coaxial cable is a prerequisite. Firstly, to keep the required signal clean of an outside interference (ingress) present in the area. In typical high rise building risers, everything from lift motors to security control systems radiate significant amounts of interference from DC (the lowest frequencies) well into the microwave band. Within the client premise, microwave range motion detectors are quite common and often operate at levels significantly stronger than the satellite signals you are trying to process.

The cables need to be physically secured throughout their route from the rooftop to the customer equipment. Cables that are free to move (in the wind, under strain) can change physical location and fall prey to RF interference fields as they do so. At a minimum, double shielded cables are necessary - preferably the quad shielded variety but here only when you are able to source connectors designed for this cable to ensure proper bonding to the shields and mechanical strength to restrain connector movement.

Line amplifiers, splitters, taps and splices (if you absolutely must have splices) must be fully screened and earthed to maintain signal purity. In this regard it is far better to install long, single unbroken runs of coax if possible - a splice is a problem waiting to happen.

Lightning protection for any antenna system mounted on a high rise rooftop (whether required by law, the building owner/manager or plain common sense) must be provided and must be adequate for the job. A "ground wire" improperly chosen is a safety hazard greater than no earth wire at all in many situations. Using #6 bare automotive "earth" wire or a normal electrician's green "earth" wire is not adequate. A 2,000 amp (surge rated) copper or silvered copper braid secured by stainless steel hardware or by silver soldering to the building lightning protection system is the absolute minimum. An inline microwave rated gaseous lightning discharge arrester is also very desirable for high rise rooftop installations. (1)

And a few thoughts and observations concerning dealing with government agencies from whom you may need permission to make an installation. If you wish your application to be approved:

- 1) Be Reasonable. Provide all of the required drawings (the first time the application is submitted) including engineering detail and antenna (wind survival) certification as provided by the antenna manufacturer. Do not expect the bureaucrat planner to know or understand anything at all about the satellite

1/ "Microwave rated" is the operative term here. Lightning arrestors designed for VHF/UHF use can create significant signal problems within the 950-2,100 MHz IF region.

PANORAMIC SATELLITE METRE

MC10-SAT

AU\$1599 (TAX-EX)

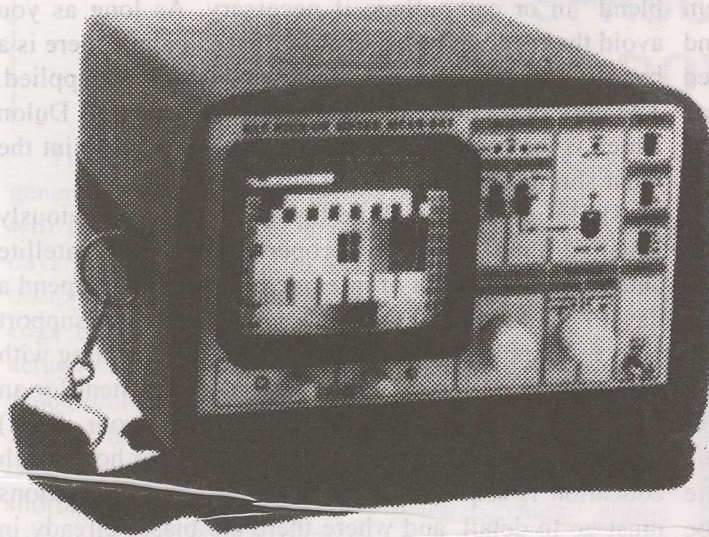

A PERIFELEC
PRODUCT

- SATELLITE POINTER AND FIELD INDICATOR WITH RECEPTION ON 14cm (5.5") SCREEN
- FREQUENCIES FROM 950 TO 2150 MHz
- DISPLAY OF FULL-BAND AND EXPANDED SPECTRUMS ANALYSER
- DISPLAY OF PICTURE OF SELECTED CHANNEL
- POSITIVE (Ku Band) AND NEGATIVE (C Band) VIDEO DEMODULATION
- MEASUREMENT OF SIGNAL RECEPTION STRENGTH BY WHITE BAR SUPERIMPOSED ON THE PICTURE AND PROPORTIONAL IN LENGTH TO THE SIGNAL IN STRENGTH
- RANGE OF MEASUREMENT OF SIGNAL STRENGTH BY WHITE BAR SUPERIMPOSED ON THE PICTURE AND PROPORTIONAL IN LENGTH TO THE SIGNAL STRENGTH
- RANGE OF MEASUREMENT OF SIGNAL STRENGTH FROM 50 TO 90 dBµV
- POWER SUPPLY TO LNB IN 14 OR 18 VOLTS AND 22 KHz
- BATTERY LIFE : ABOUT 1 HOUR
- WEIGHT : 5.1Kg

THE MC10-SAT SATELLITE FIELD STRENGTH METER IS NOW CONSIDERED AS THE ESSENTIAL TOOL FOR ADJUSTING SATELLITE RECEPTION DISHES. THE VISUALISATION OF THE SPECTRUM AND THE PICTURE ALLOWS THE CARRYING OUT OF ALL THE NECESSARY ADJUSTMENTS WITH THIS ONE INSTRUMENT.

FREQUENCY RANGE : from 950 to 2150 MHz
TUNING: Multiturn potentiometer
INPUT IMPEDANCE : 75 Ohms
INPUT CONNECTOR : F-TYPE
INPUT ATTENUATOR : 0.10 & 20 dB USING 3 POSITION SWITCH

SIGNAL STRENGTH :

- **INDICATION :** by a white bar superimposed on the picture, its length being proportional to the strength of the received signal, and also by audio indicator
 - **READING :** on the scale from 0 to 70 dBµV
 - **MEASUREMENT RANGE :** from 50 to 90 dBµV
- LNB POWER SUPPLY :** 14 or 18 V and 22 KHz by switch

DISPLAY ON 5.5" CATHODE TUBE

- **SPECTRUM :**
- Full band spectrum (FROM 950 TO 2150 MHz)

- Expanded Spectrum with visualisation of the counter-polarisations

- PICTURE :

- positive video polarity (Ku Band) or negative video polarity (C Band)
- Picture of selected channel only
- Picture of selected channel with signal strength indication

POWER SUPPLY : 12V, 3 AH battery

CONSUMPTION : 1.2 A (without LNB)

BATTERY LIFE : about 1 hour

CHARGING TIME : about 4 hours

DIMENSIONS : 240 x 140 x 270mm

WEIGHT : 5.1Kg

ACCESSORIES INCLUDED : Measurement cord, AC mains adaptor, charging lead for car cigar-lighter, case.

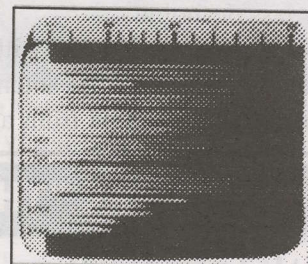

FULL BAND SPECTRUM

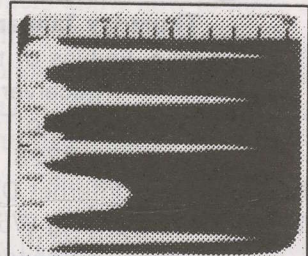

EXPANDED SPECTRUM



DEMODULATED PICTURE



PICTURE + MEASUREMENT



TEL 61-2-584 1233 FAX 61-2-584 1452

99-105 BOUNDARY ROAD, PEAKHURST NSW 2210 AUSTRALIA

system. Tell them all that is required for them to know - such as "why" the system is needed (i.e., how it will be used), "how" big the antenna must be (to capture the minimum amount of signal required to make the system function), "where" it will be pointed in elevation and azimuth (because it must point directly at the intended satellite if the system is to function). It has been my practice to submit two photos - one taken of the proposed installation point as it exists, a second with a scaled (drawing) overlay of the same site with the antenna in place. If you are able, also submit photographs of similar installations you have done (or others have properly done) before and after an installation. I make it a rule to never request a larger antenna than actually required and to point that out in the application. (2) Remember, to a planner, bigger means less desirable.

2) Be flexible. Go in with at least two alternate physical locations for the antenna. One of these can be genuinely less desirable from an aesthetic and planning

view, the other a genuine alternative. If the dish surface colour (and mount) will clash with the building / skyline, be prepared to paint the whole assembly to blend in or camouflage if necessary. As long as you avoid the metallic based or water based paints, there is a broad range of suitable treatments which can be applied. The very best choice (although pricey) is aircraft Dulon which is microwave transparent and is used to paint the radar shrouds on commercial airliners.

3) Be resourceful. Investigate all of the previously installed (and hopefully properly approved) satellite antennas in your area of interest. It might pay to spend a day to photograph them for your files and to support your own applications. If possible, set up a meeting with the relevant officer(s) of the planning department for an informal discussion before you submit your (first) proposal. This will help you determine just how much education is required, to what extent your applications must go to detail, and where there are biases already in place which you have to work around.

Follow-up is always required. If possible, provide full documentation for each installation after it is completed. And if possible, where they will require an inspection of the installation for final approval, be present. When you next apply, include the facts from the previous installation(s) as points of reference. It has been my experience that after the fifth or sixth quality installation you complete, the approval process for new applications can become as simple as handing in the forms and receiving an instant "verbal O.K." based upon the new installation being substantially similar to those which have previously made the planning officer happy.

Finally, the future success of commercial installations can have a very positive effect on your bank balance. Commercial installations command a significant monetary premium over domestic or pay-TV work since by their very nature they are one-off specialised installations for which the customer is normally quite prepared to pay. It is essential however, both to your success and to the acceptance by the general public of satellite receive systems, that the completed installation is something that you are more than willing to have identified as "your work." It must be structurally sound, aesthetically pleasing, technically sound and intrinsically safe to meet these criteria.

2/ The concept here is to educate the planner about the relationship between circuit performance and dish size. If he/she grasps that antenna size is not an arbitrary factor, but a well engineered part of the system plan, they will often be less negative towards the dish size aspect of the application.

What you are trying to convey is simply, "The minimum dish size that will create the desired connection to satellite is X.X metre diameter," a factor over which you - the installer - have little or no control.

DIDN'T MAKE "THE SHOW" ???

We got it all on videotape!

Thursday January 23rd:

ThT1: Facts & Foibles of the DVB Compliant Receivers

ThT2: What S-A Forgot to Tell You About the SA 9223

ThT3: Basis For Internet Delivery Via Satellite

ThT4: The Expanding World of Asia/Pacific Satellites

Friday January 24th:

FrT1: The Real World of Cable TV Entrepreneurship

FrT2: Satellite Dish Selection Criteria

FrT3: Satellite Master Antenna Systems

FrT4: Practical Ways to Segment CATV/SMATV Bandwidths

FrT5: Safe and Sane Antenna Dish Mounts

FrT6: Practical Tips For DVB IRD Installs

Saturday January 25th:

SaT1: 1997 Legislative Campaign - Family Television Network

SaT2 & T3: Sky Network Ku-Direct Seminar

SaT4 & T5: SPACE/PC Magazine Internet Via Satellite Symposium

PRICING: All tapes (VHS) \$29 each (note SaT2 and T3, T4 and T5 are two-tape sets; \$58). Complete set all tapes (15 total) package price \$300.

FAMILY TELEVISION NETWORK

PO Box 303, Warkworth 1241, NZ

Tel. 64-9-425-4054

Fax 64-9-425-6718

-SPRSCS '97- SHOW of SHOWS DOWN IN ATTENDANCE

The crowds were larger in 1996, and possibly the general mood was more festive. But for content - 1997 will be remembered as a serious, work oriented three days. Those who came to have fun and drink beer were disappointed. Those who came to sample the leading edge of new technology, ask important questions and actually touch and use the very latest hardware were not disappointed.

The major issues were DVB Compliant receivers, DVB Compliant receivers and DVB Compliant receivers. A shortage of dish system sales to the consumer public was on the mind of New Zealanders - Australians were mostly jubilant (if confused by MPEG receivers) because sales supporting the European Bouquet are exceeding predictions in many areas.

The era of "TVRO as a hobby" is plainly on the wane, going the way of laser discs and 8-track tapes. Suppliers who depend largely on the "hobby element" for their livelihood were disappointed that even with a ten fold increase in programming over a year ago, hobby sales are down and disappearing rapidly.

And everybody - everybody - was "mad as hell" at the inconsiderate programmers who are making special deals with specific receiver suppliers as a marketing tool to control who does and does not have access to their programming. Robin Colquhoun's January 23 session ("What Scientific Atlanta Forgot To Tell You About the D9223") was well attended and more than a tad controversial. *"Who really cares that the 9223 can do those great things if it takes a computer whiz with lots of time on his hands to accomplish what Robin showed us?"* several complained. *"I was impressed with Robin's abilities - but I will never do it myself because it has no place in a consumer environment"* suggested another. *"Robin is the super hobbyist carried to the Nth degree"* offered another, *"but he doesn't represent any money in my pocket. So why have this even on the schedule when we have so many vital issues to explore?"*

There was a reason. Colquhoun's D9223 pushes the envelope of compatibility, accessing as it does virtually every variant of MPEG-2 now in the air in the Pacific and Asia (with the obvious exception of those transmitted using conditional access). His one-off D9223 does what every consumer receiver should do - but to date none will do. That there is software (inside of his D9223 and in his support PC that runs the IRD) that flips from any of the ten new Chinese services on As2 to EBB to Star TV to NBC and on and on and



"Don't ever believe them - again." When MPEG receiver suppliers tell you it cannot be done, suggest they order and view SPRSCS '97 tape ThT2 (p. 10). Robin Colquhoun unmasks the D9223.

on ... without a blip or burble tells us that SA and the rest of the receiver suppliers know how to make such a consumer unit but for selfish reasons have chosen not to do so. Before the Colquhoun session, when a receiver designer told us *"We can't do EBB and PowerVu on one unit"* we had to accept the statement as gospel. Now we know that is a lie. And we want the receiver suppliers to be aware that we know this. Colquhoun demystified the process, and for that we will all be better off. Maybe not today - but one day.

Mark Long was, as always, brilliant. His two day cram course (the SPACE Technical Certificate sessions) was attended by 17 from PNG, Vanuatu, Australia, New Zealand and elsewhere. Mark's January 23rd session that explored the huge changes coming over the next 12 months in satellites deployed to the Pacific and Asia, ended with his own pet forecast: *"Ku will become very significant to you by 1998. You may even forget totally about C-band by the time we meet in 1999!"* Re-enforcing that view, his four hour Sky Ku-Direct January 25th mini-course was very well attended (more than 100 at peak times) as dozens of Sky terrestrial aerial installers from throughout New

1/ The twin tapes of this mini-course (SaT2 and SaT3) should be very popular for training Sky satellite installers. SPACE has asked Sky NOT to use these tapes without first obtaining SPACE's permission but there is no reason why individuals and firms planning to work with Sky shouldn't make them the foundation for staff training (see p. 10, ordering information).

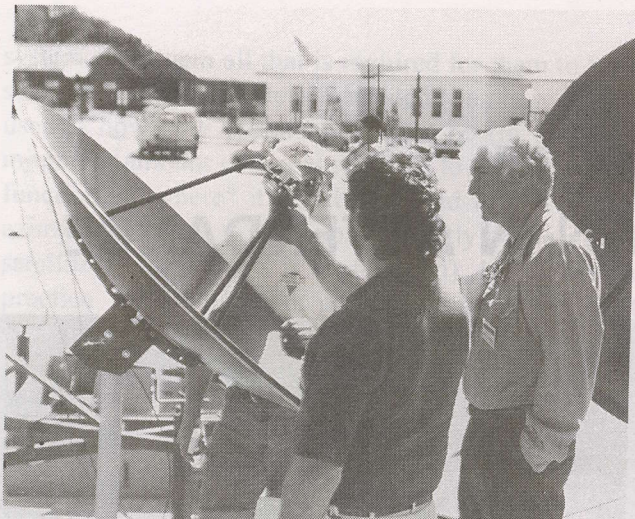

Sky Network NZ's Andy Huljich (r), Dean Silk (back to camera) discuss fine points of Optus "fringe area" reception with Norm Bruner (Paracclipse / Bay Satellite)



Host and guest. Selwyn Cathcart (Telsat Communications - left) and Mike Kohler (Orbiton, Wisconsin) during antenna set-up. Telsat distributes Orbitron product in the Pacific.

Zealand sat to learn the basics of small dish consumer DTH pay TV installs. (1)

There were disappointments. Perhaps the largest was an equipment failure which prevented attendees from witnessing first hand (and as pre-billed, the first time outside of Europe) the Deutsche Welle sponsored MediaNet (Internet via satellite) service. Here's what happened. Just five days ahead of SPRSCS, Johannes Firsbach of DW advised with some glee, "*It is working through AsiaSat - we can do a live demonstration.*" He asked that we locate a DMV (NTL) 3000 receiver for the demo. Why? Because the buried-in-the-vertical-blanking interval MediaNet service had to be brought out of the DW MPEG-2 service separately and then re-injected back into the analogue configured DW video signal for access and display. The only available circuit board to do this was configured to slide into the professional DMV 3000 receiver. Leon Senior of Skandia Electronics readily agreed to haul a DMV 3000 (which they keep in stock in Melbourne) with him for this purpose.

Alas, when all of the pieces were plugged together (AsiaSat 2 service to LNB to cable to DMV 3000 to special board for DMV 3000 to video output port on DMV 3000 to consumer level MediaNet interface [decoder] box to PC to display screen - nothing happened. With 24 hours to go until "show time," when Johannes was scheduled to take the stage to demonstrate, some very quick trouble shooting was required. What we needed - and did not have - was a "line grabber," a device that allows you to dial up a specific line of the television picture and analyse the content of that line. If the MediaNet signal was getting out of Germany and through the Bezek (Israel) downlink / uplink and back to AsiaSat 2 ... and then across the Indian and Pacific oceans to the downlink

dish at the Tamaki Campus of the University of Auckland, we should be able to see the data stream on a display scope that was fed by a line grabber tuned to the image lines (6 through 11) which are used for transmitting this information. Try to find a line grabber on short notice! Overnight, attendee Peter Kell of Christchurch Polytechnic was able to have one shipped up from South Island (the miracle of overnight courier) and a small crew gathered in the Baysat room (where the DMV 3000 was housed) to trace the data signal. Sure enough - there it was coming out of the DMV 3000 and going into the consumer level decoder box for MediaNet. Alas - here the data stream stopped. At some point in the short life of this decoder box, a careless person had unplugged its interconnecting cables while the power supply was on - normally not a big problem but this was a prototype decoder and it lacked the necessary electronic safety features to prevent a static discharge component failure.

MediaNet to be displayed live - was dead. This was Thursday and Johannes Firsbach hoped (against hope) that before the special Saturday session a replacement box could be couriered out from Germany. Regrettably it did not make the trip in time. And being the



ADL co-founder, developer of just about every significant C-band feed innovation for last two decades - ADL's Gary Blachley with Coop.



PERFECT 10

*The Perfect choice
for your satellite
reception!*

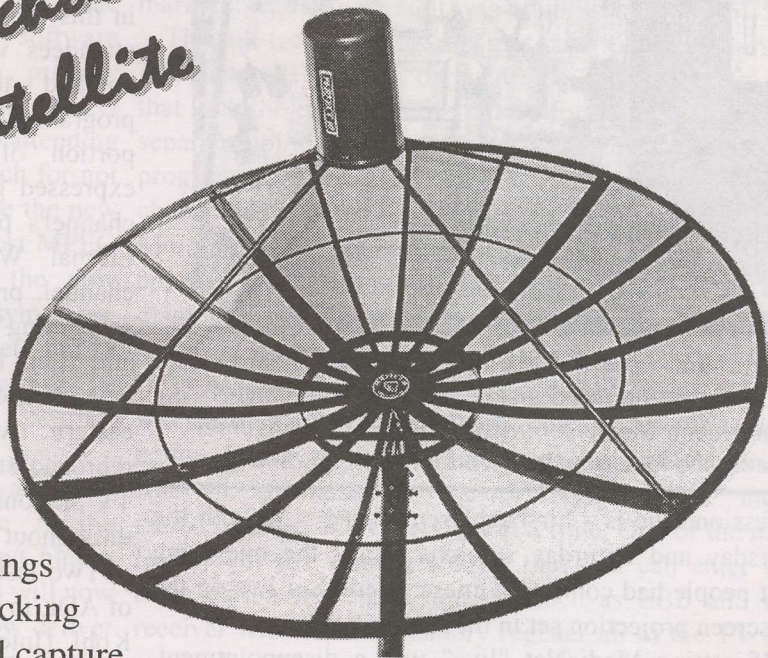

**Consider these
strong points:**

- Thru-Axle Design
- Lifetime lubricated bushings
- Long Beam for easier tracking
- Six bolt cap for increased capture
- Larger than industry standard rings
- Caps up to 455mm Tall (easier tracking)
- Extra Heavy Duty declination bolts (3/4")
- Electroplated zinc and powder coated mounts
- Easy to assemble 5 rib quad panel for quick installation.

WT180 P	1.8 Polar Mount
WT230 P	2.4m Polar Mount
WT230 PHD	2.4m Heavy Duty Polar Mount
WT300P	3.0m Polar Mount
WT353P	3.5m Polar Mount
WT442P	4.4m Polar Mount 8 Panel

MADE IN THE USA

For further information, specifications, wind loadings etc contact:



WINSCOT TRADING PTY. LTD.

Unit 2/186 York Street, South Melbourne VIC 3205

Phone: 61(0)3 9699 5740 Fax: 61(0)3 9690 9006

Email: WINSOT@netoptions.com.au

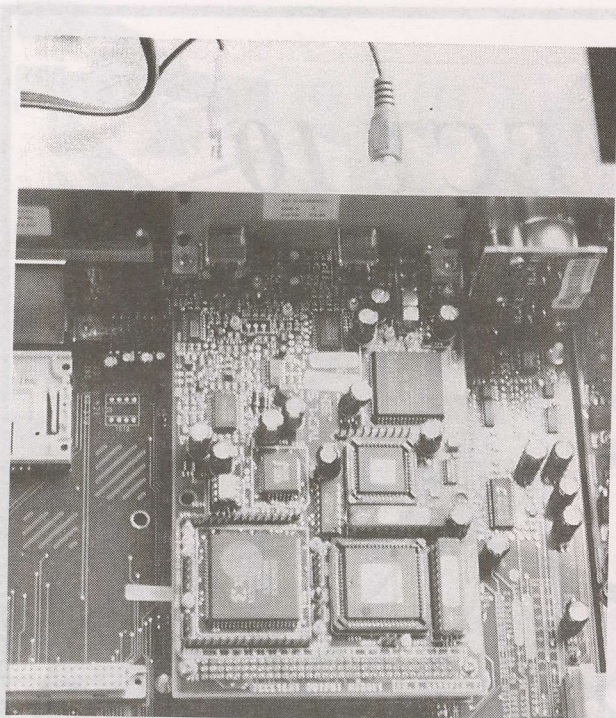

Did its' job. Special DMV created plug-in board (top, centre) mounted inside DMV 3000 receiver produced MediaNet within VBI. But a consumer grade decoder that followed left us high and dry.

professional he is - Firsbach went ahead with both the Thursday and Saturday sessions minus the one thing most people had come to witness; MediaNet live on the big screen projection set in the learning theatre.

If getting MediaNet "live" was a disappointment, many managed to make up for it by mounting a technical attack on the host Barrycourt "Adult Movie" in-room service. Since SPRSCS '96, an Auckland firm (Cablevision Systems) has installed a pricey in room movie on demand system using the 300 to 450 MHz spectrum of the hotel's new SMATV distribution system. Cablevision Systems has elected not to encode the movies (as in scrambling) but instead relies on modifications to the host hotel's (Goldstar) TV sets to prevent unauthorised viewing of the movies. At \$12.95 a movie (plus gst) there was plenty of reason to be challenged. Or so attendees thought.

Several techniques were tried - all apparently worked and shortly there were complaints about the quality and selection of adult (read - some grade of pornographic) films available. *"These films must have been edited for airline use!"* complained one hacker; *"I've seen better action on a corner of Queen Street"* (a portion of Auckland with a reputation problem). A thoughtful attendee wrote a two page letter to the Barrycourt suggesting several things Cablevision Systems might do to improve the "security" of the pay movie service. Doubtless future system hackers will have a more difficult time in the future; and probably be equally disappointed with the "content" after they get there!

Offsetting the disappointment of the MediaNet live demo failure and the widely voted "poor quality of adult flicks" on the Barrycourt system so many hacked was the appearance of Jim Hodgetts from TV5 Paris and Giovanni De Luca from RAI International. Both showed keen interest in expanding their viewing in the Pacific and Hodgetts believed he had made good arrangements with a number of widely scattered cable TV systems (from Papua New Guinea to New Zealand and Australia) for his service. Giovanni, as discussed on p. 1 in this issue, was on new ground because most of the attendees were prepared to "roast RAI" rather than applaud the unexpected announcement of new programming content specially developed for our portion of the world. Another programmer who expressed great pleasure with the reception given his channel's programming was Christopher Wegemer of Eternal Word Television Network (EWTN). The channel, produced as the Global Catholic Network, is scheduling a significant line-up change April 1 and will add films ("Cinema") five days per week along with new children's programming blocks - all retimed to suit eastern Australia viewing. EWTN signed some rebroadcast deals with New Zealand terrestrial (UHF) TV stations while here and added new cable affiliates throughout the Pacific region.

Two last minute arrivals, Gary Blachley (co-founder of ADL in California - the antenna feed firm) and Mike Kohl (International Sales Manager for Orbitron in Wisconsin) were given a Saturday midday hour to answer questions concerning their respective areas of expertise - feeds and dish surfaces. This was an "unscheduled treat" since the two were pioneers from the earliest C-band home dish industry in the United States (Gary's feed designs date from the mid 70s, Mike started in the industry in a remote Alaskan town where he pioneered dish reception).

Was SPRSCS '97 a success? For those who came to learn and exchange data - it was. For those who came because - well, they had nothing better to do - it was not. All of which is part of the weaning process the industry now faces. Those who see this as the next great business opportunity walked away smiling - which is why we do this each year!



SPRSCS BRINGS OUT THE BEST - AND WORST - IN MPEG RECEIVERS

Perspective. Robin Colquhoun's session with his much bastardised D9223 software either made you envious (perhaps jealous), made you wish you had the inclination to learn more about computer software programming, or put you to sleep. The primary excitement of the show were ten new MPEG programme channels that virtually nobody attending could understand and most would sit and watch for not more than a few minutes at a time. They were the new "forbidden fruit," just beyond the reach of most MPEG receiver owners because they do not fit the now increasingly familiar world of FECs and Msym rates. They have been dubbed the "Chinese Bouquet" but in fact they are not a bouquet at all; they are 10 programme channels on 9 separate carriers.

We illustrate how they appear on a spectrum analyser, and diagram their identity, below. There is the conception that where there are Mandarin/Chinese speaking peoples, a TVRO (home dish system) will now "easily sell" if the installer/dealer can somehow deliver these programme channels into the home. In fact, a relatively simplistic dish installation, fixed on the horizontal polarity side of As2, equipped with the appropriate MPEG-2 DVB receiver will produce not only these 10 programme channels from China, but also the five European Bouquet TV channels plus the 12 EBB radio channels.

The operative word is "appropriate" (MPEG-2 DVB receiver). Is there such a receiver presently in the marketplace? If there is, it was not present at SPRSCS.

The full technical (tuning) particulars for the Chinese Bouquet (CB) appear on pages 26-27. Suffice to say that with the exception of "Inner Mongolia," these are 9 separate uplink transmitters each carrying a single TV programme (some also have an extra radio programme channel as well in the unused audio channel). Inner Mongolia has two programme channels (and thus appears wider on the spectrum analyser and in our diagram below).

Here is what we sorted out during "the show."

1) A Nokia model 9500-S (software version 1.63) will receive all of the MPEG you see in the model below. However, nobody (including Robin Colquhoun) was able to make this receiver "register stack" more than 4 of these SCPC services at a time. One of the nice features of the version 1.63 is that you can enter the basic parameters for a bouquet such as EBB and the receiver will stack in memory register all of the TV (5) and radio (12) programme selections. Once stacked (and listed on the user menu), you channel surf by simply selecting the one you wish with the remote, or surf up or down in channel numbers with the arrow button. And to the limit of the register capacity, additional bouquets come up directly from menu or up/down arrow selection. Which brings us to ...

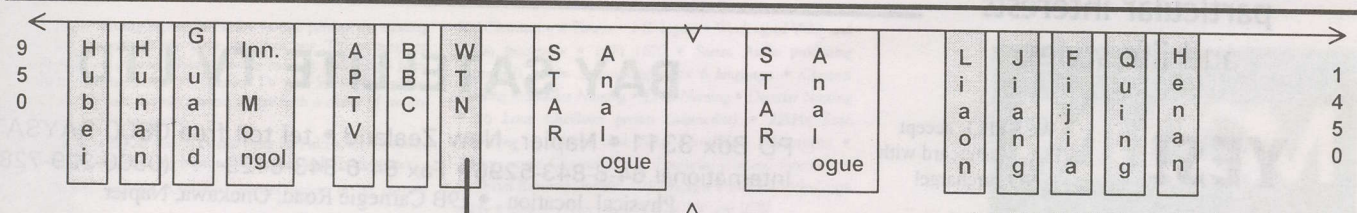
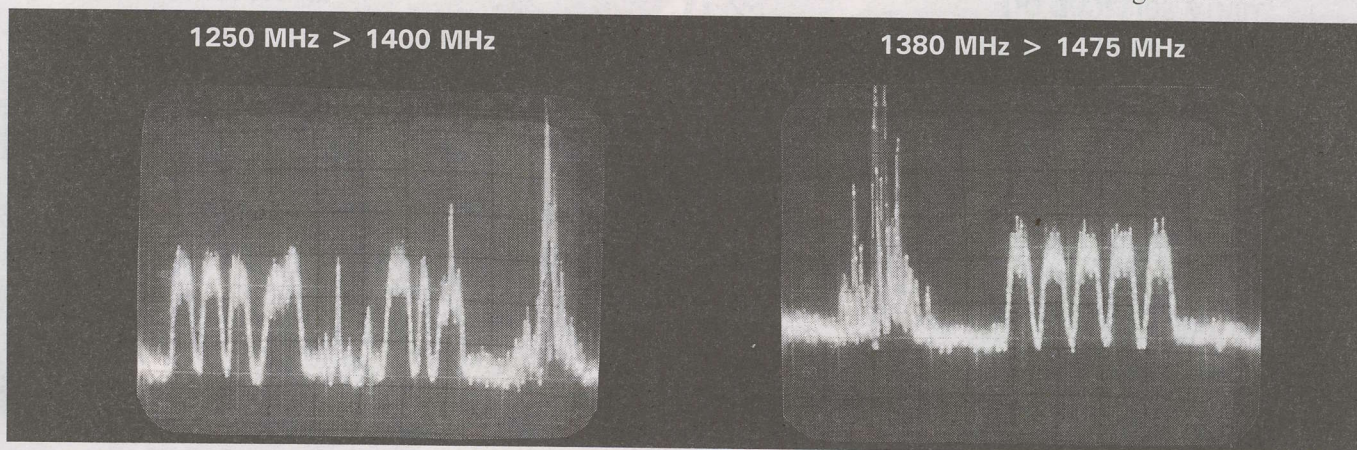

AsiaSat 2 / Horizontal polarity

"Shaded" are MPEG-2 signals that can be tuned with Nokia 1.63

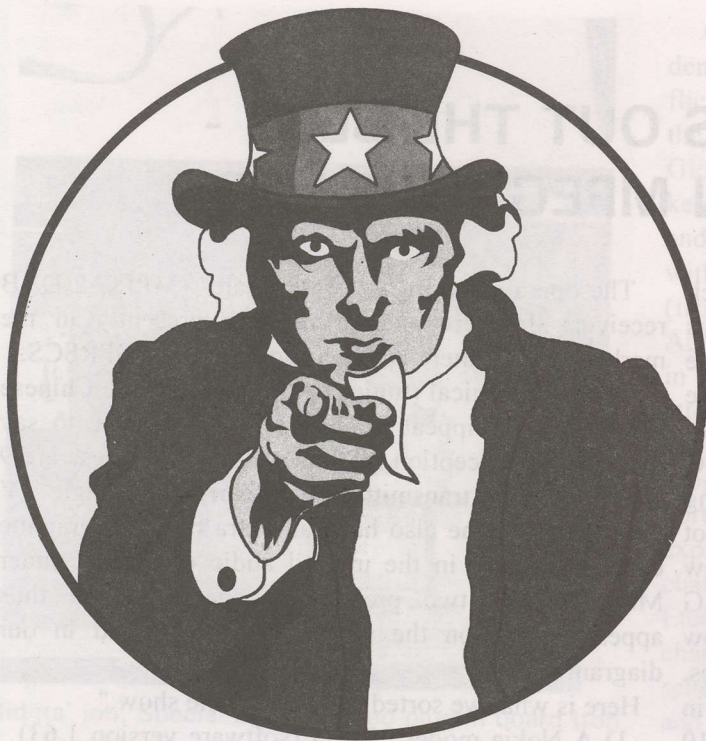

SO ...
YOU WANT TO
INSTALL SATELLITE?

HAVE YOU
JOINED THE
BAYSAT TEAM?

UNCLE BAYSAT would like to remind you that satellite TV does not begin ... and end ... with the new SKY Network service.

There are many, many services on satellite which appeal to tens of thousands of viewers in the South Pacific. We believe these viewers would be quick off the mark to purchase a system that is designed for their particular interests and life styles.

We are forging ahead to create system packages that are easy to sell, quick to install, low in "profile," high in performance and most importantly - **profitable** to you, the dealer.

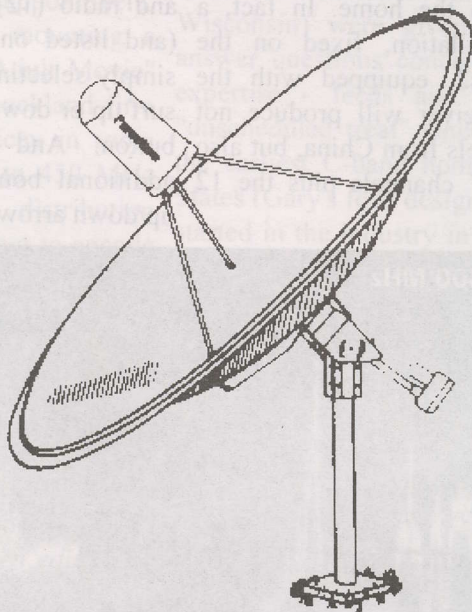

Paraclipse 1.5m Hydro

Our Paraclipse 1.5m **Hydro** for example produces P5 reception from CFI Paris in a complete dealer package under \$800 (+gst)! And we now have cheaper packages of PowerVu (CMT, EWTN) and MPEG-2 DVB coupled with innovative marketing assistance that makes you the local satellite expert.

And remember - Uncle Baysat doesn't send staff into "your patch" to compete with you!

You are just a toll free call away from joining the team that puts profit into satellite TV!

YES!

We **STILL** accept
VISA, Mastercard with
NO surcharge!

BAY SATELLITE TV LTD

PO Box 3311 • Napier, New Zealand • tel toll free 0800-BAYSAT
International 64-6-843-5296 • Fax 64-6-843-6429 (0800-229-728)
Physical location • 19B Carnegie Road, Onekawa, Napier
<http://www.baysat.co.nz/baysat>
e-mail john@baysat.co.nz

SL-8000RP

4500 years ago, the Egyptians were so far advanced in building technology that the pyramids were considered to be one of the Seven Wonders of the World. Today, still standing, these magnificent shrines to the achievements of man leave us marvelling at the skill and dedication of these ancient people. Fine craftsmanship is truly an ageless art.

Palcom receivers reflect skills and craftsmanship based on the same traditional values. The flagship of the Palcom range, the SL-8000RP is another marvel of technology.

From BC2500 to SL-8000RP

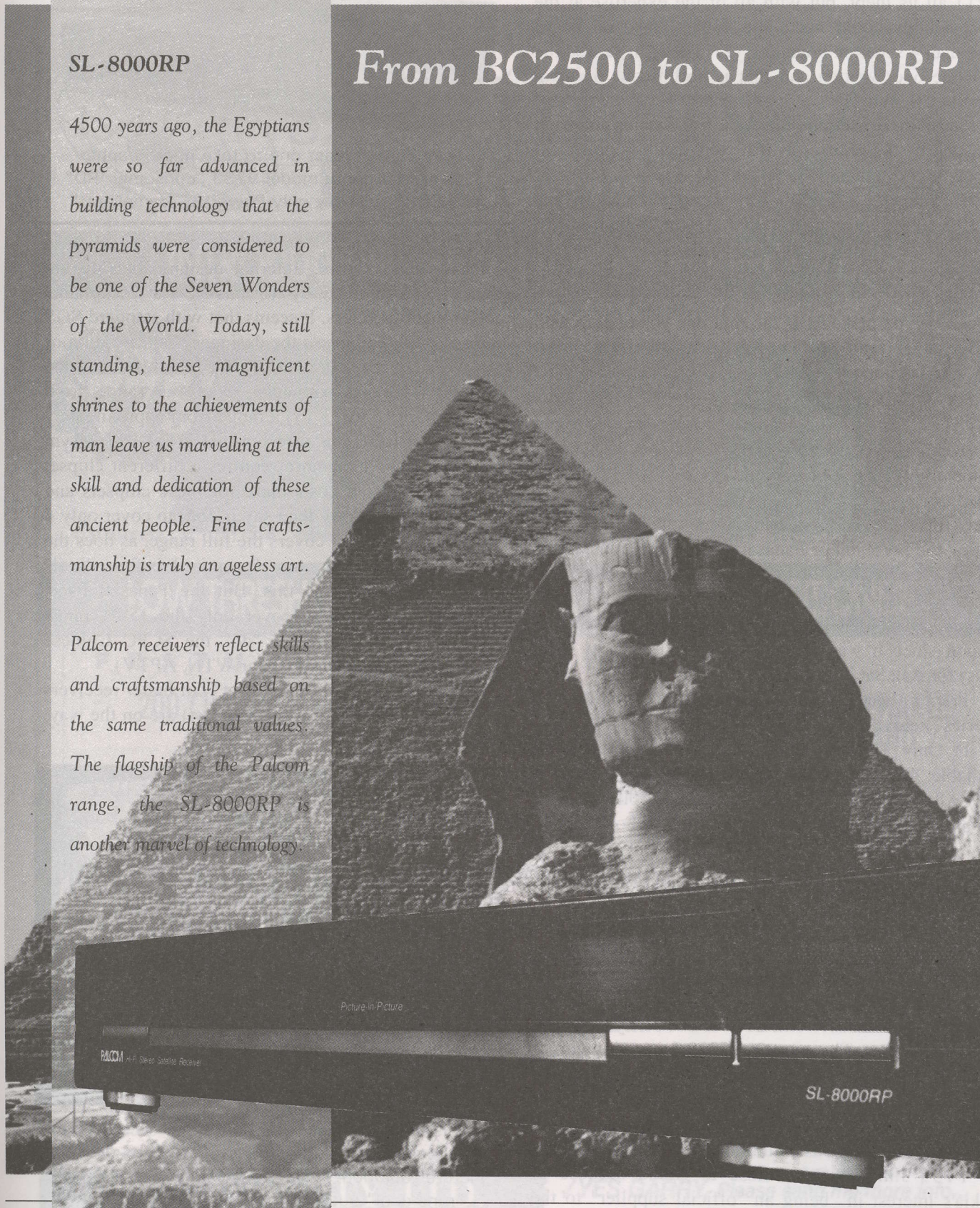

Its unique moving Picture-in-Picture feature permits the viewing of two channels at the same time (on one TV or two) or watching one channel whilst recording another. Mix images from satellite and terrestrial TV, satellite TV with VCR playback or satellite TV and security camera output with a choice of picture size for each image source.

The weakest signals may be viewed using the Palcom low threshold tuning facility producing improved video and audio performance.

A built-in antenna positioner provides access to all current satellites

500 Channels • 2 Tuners • 3 IF Inputs • Weak signal Video and Audio processing • HiFi 1600 • Stereo Audio processing (surround) • On Screen Display in 6 languages • Channel Naming • Satellite Naming • LNB Naming • Decoder Naming • 16 Local Oscillator presets (adjustable) • 22kHz Tone Switching • Global and Fine Ferro/Skew adjustment • Alphanumeric Channel List • Favourite Channel Function • 16 Preset External Decoder configurations • Internal VideoCrypt ready • Timer / Priority switching for TV and VCR

with software by....

PALCOM

State of the Art Simplicity

2) Call us inept, but with all of the expertise at the show nobody could make the 9500 S take on board more than 4 separate bouquets. (2) The fifth caused the 1st to be over written and that is an obvious problem with the CB. Why?

Because there are nine different frequencies and each is treated by the register as if it were a full bouquet. So at most you can memorise (stack into register) only 4 of the 9. That is not a friendly way to programme and then hand to a consumer an installed system. Which leaves the consumer having to develop skills enabling them to reprogram on their own anything beyond the first four "bouquets."

Now - if you make EBB the first one you end up with 5 TV and 12 radio in that register. Which leaves you will 3 more bouquet groups to select out of the nine available from the Chinese.

3) There were 3 Nokia version 1.63 at the show and on several occasions two of the three ended up being compared against other receivers and one another. Based upon these tests, we are not comfortable that the tuner (front end) of any of the three units was as good as, say, the DVR500 or Panasat or SK888. Translation? Sensitivity. We believe it takes more signal (better carrier to noise) for the 9500 S to "lock on" than many of the alternate models. This may be peculiar to the 1.63 version since it was produced in small quantity (100 units) for AsiaSat 2 test only.

Pricing. Better yet - availability. We have two "stories" here; take your pick.

1) Only 100 test units were built, no more are available. And story two -

2) After the first 100, a second run of 500 was built and are available in lots of ten at a time. Who from and how much? Follows a quotation recorded during the show from Selwyn Cathcart, speaking on behalf of Telsat and Clayson Gibbons of G & G Imports.

"Our offer is for ten units, cash with order, for delivery in weeks 9 /10 (February 24-March 7); freight is FOB (Darwin) Australia. It comes with no taxes paid. Australian orders are taken by G & G Imports (Australasia) and New Zealand by Telsat Communications. The price is A\$850 for a minimum of ten units; this is a tax exempt price in both Australia and New Zealand (i.e. taxes are extra where applicable)." A New Zealand buyer would pay A\$850 each plus freight from Darwin plus gst as a minimum.

TV5's Jim Hodgetts, close to Nokia because of Nokia's interest in being an "official supplier" to the EBB, advises there is "no real interest at Nokia to deal with single lot or small quantity orders; they are simply too big, too complex an organisation to sell units one at a time. So they have established a subsidiary to do this and there is a mark-up taking place between the two. In my option, this is a fair price for this unit."

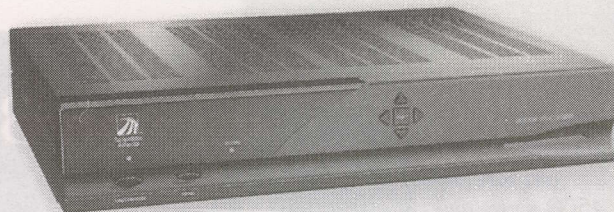

They built at least one to take photographs - Scientific Atlanta model 9233 "consumer IRD" MPEG-2; possibly only PowerVu "compliant."

A more nagging problem emphasised during the show is the design method (i.e., internal design, not software design) being adopted by various "DVB Compliant" receiver manufacturers. It seems that with standard SGS Thomson MPEG chipsets the designer has the option of (1) making the receiver function for Msym rates in the range of 4 to approximately 15, (2) a range from approximately 10 to 23, (3) a range from approximately 15 to 31. Designing a receiver that covers all Msym rates from 1 to 31 or more requires a different chipset architecture - and it costs more for these chipsets and the supporting circuitry than say it does to cover only 4 to 15. The SA D9223 covers the full range, as does the Nokia V1.63. Several more "promised before April" claim they will also do this. But the Panasat, Pace, Skandia family typically cover only the 15-31 range which means they will not "do" the SCPC Chinese signals previously discussed (nor WTN, APTV).

Summary: We are not there "yet" but better receivers for all levels (consumer and enthusiast) are on the way; the trek continues!



This is what happens when an SK888 is subjected to excessive heating; overlay of video on desired picture. Solution? Quick fix: The receiver by itself "runs cool" but does not like heat from other electronics. Don't stack equipment!

2/ Instructions with the V1.63 are woefully inadequate; not a complaint as this was a limited production unit for field evaluation. If there is some secret method of stacking more bouquets than we were able to do, we invite feedback from anyone out there that can enlighten us!

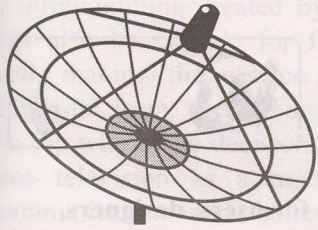

AV-COMM SATELLITE TV EQUIPMENT

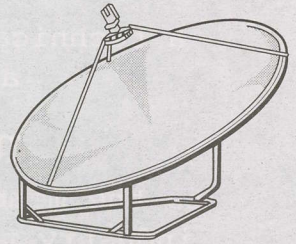

INTRODUCING THE DYNASAT 300P RECEIVER

*Plus Australian sales tax if applicable

ONLY
\$775*

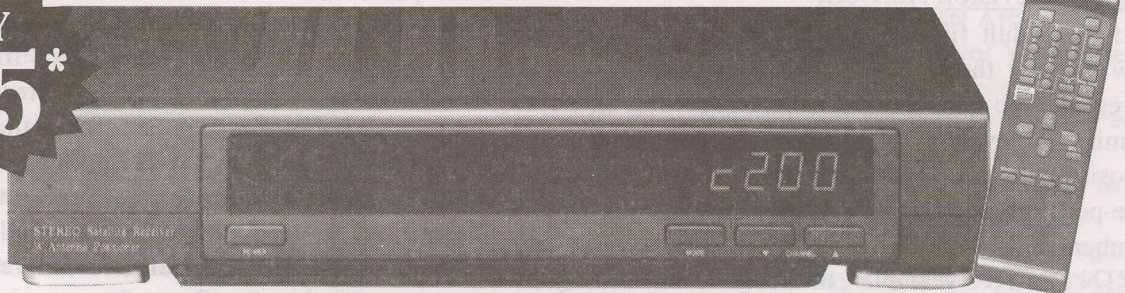

CAT #R1152

LOW THRESHOLD RECEIVER WITH DUAL AXIS POSITIONER

FEATURES

- 200 CHANNELS •••➔ PRE-PROGRAMMED WITH 90 CHANNELS VIEWABLE FROM AUSTRALIA & 40 FROM NEW ZEALAND.
- DUAL AXIS POSITIONER ••••➔ FOR INCLINED ORBIT SATELLITES
- DUAL INPUTS ••••➔ ALLOWS DUAL DISH/BAND OPERATION
- SCART & RCA OUTPUTS •••➔ MAXIMUM INTERCONNECTION FLEXIBILITY
- DUAL BANDWIDTHS ••➔ SUITABLE FOR HALF TRANSPONDER OPERATION
- FREQUENCY SCAN ••••➔ SEARCH FOR UNKNOWN FREQUENCIES
- 14/18V SWITCHING ••••➔ USE DUAL POLARITY OR WIDEBAND LNB
- 20 STEP THRESHOLD EXT ••••➔ PRESET THE EXACT THRESHOLD FOR EACH CHANNEL

**We reserve the right to improve product performance without notice.*

BENEFITS

AV-COMM PTY. LTD.

DIRECT IMPORTER ACN 002 174 478
PO BOX 225, BALGOWLAH 2093

TEL: 61 2 9949 7417 9948 2667

FAX: 61 2 9949 7095

VISIT OUR WEB SITE AT

<http://www.avcomm.com.au>

✓YES GARRY, Please send me more info...

Name: _____

Address: _____

P'code: _____

Phone: _____

a technical and marketing
advisory

memo

to the membership from your
industry trade association

SPACE Pacific

Satellite
Programme
Access
CommittEe



A trade association for users, designers,
installers, sellers of private satellite-direct
systems in the Pacific Ocean & Asia Regions

Family Television Network

If the "adult film channels" available on a pay per view basis at the SPRSCS host Barrycourt Motor Inn represents one end of the available viewing spectrum, "Family Television Network" could represent the opposite extreme. More important, FTN represents a once-per-lifetime business opportunity for SPACE members.

FTN is a five year plan that began with the sign-on this past November of channel 60 at Snells Beach (Warkworth), North Island (New Zealand). This medium power UHF terrestrial broadcast service presently serves a limited geographic region along the growing northern boundary of the Auckland metropolitan region. FTN in its present form averages 12 hours of programming per day, but is scheduled to grow into a 24 hour per day schedule by anniversary one.

FTN is owned and managed by Integrity Television, a not-for-profit trust that operates a school and functions in a world of public service. "Family values," the importance of the family as a cohesive unit, is at the heart of all activities.

FTN's Trevor Yaxley met with SPACE members in closed session January 25th during SPRSCS where he explained the business plan for the network as well as the business opportunities he envisions for SPACE members.

FTN's Snells Beach facility, collocated with their school and public service unit, includes production and

live presentation facilities. This will grow into a "network operations centre" which will feed programming to "affiliate stations" throughout New Zealand the Pacific. FTN is presently building additional outlets that can be reached through terrestrial relay fed directly from Snells Beach as the first phase of the network building program. Yes - satellite relay will be utilised to feed programming to additional outlets beyond reach of economical terrestrial relay circuits.

Most existing Pacific region networks function by having one or two primary production centres (TVNZ's Auckland, Wellington facilities as an example) which feed essentially the same content programming to all interconnected stations. This creates "national networks" with identical programming content and each TV transmitter is network owned and operated essentially as a no-local-input "relay" station.

FTN has elected to follow the North American model where individual stations are individually owned and operated by the "affiliates." Each affiliate station will be created by a group local to the region it serves and each affiliate will become a "programming content partner" in the network operation. The essential difference here is that rather than having one "national viewpoint" reflected on each area's FTN transmitter, the individual affiliate stations will mix a blend of network created programming with local (and regional) programming. In this way the individual stations will more perfectly reflect the wants, needs and concerns of each community. An FTN affiliate station will have the "security" of a full day of programming fed to it by

MEMBERSHIP IN SPACE

Membership in SPACE Pacific is open to any individual or firm involved in the "satellite-direct" world in the Pacific and Asia regions. There are four levels of membership covering "Individuals," the "Installer/Dealer," the "Cable/SMATV Operator," and the "Importer/Distributor/Programmer."

All levels receive periodic programme and equipment access updates from SPACE, significant discounts on goods and services from some member firms, and major discounts while attending the annual SPRCS (industry trade show) each January. Members also participate in policy creation forums, have correspondence training courses available. To find out more, contact (fax) 64-9-406-1083 or use information request card, page 34, this issue of SatFACTS. Page space within SatFACTS is donated each month to the trade association without cost by the publisher.

(satellite) relay around which it can build its own local or regional programming needs.

Programming created by localised affiliate stations will also be eligible for full network distribution as well, making the service "two-way" in nature. In simplistic form, present day television has "bosses" at the top who make decisions for an entire country; FTN sees television as a medium of local or regional communication and believes that each community should have the opportunity to fund, build and operate its own station as an expression of that region.

And what might the business opportunities be? First is the ownership of the station. Groups or individuals building stations will have the technical and programming assistance of FTN from the outset. Group purchase of essential transmission equipment, directly from the hardware suppliers, will significantly reduce the individual station costs. "Shared" engineering, "shared" programming feeds, and a co-operative approach to operating the network all add up to budget priced stations.

The most simplistic station envisioned is a ten watt transmitter serving a radius of up to 10 kilometres in diameter. Fed totally by satellite (i.e., no local origination equipment), such a station budgets in the region of NZ\$25,000 installed; including the ability to "slot in" (play within programming) locally sold and produced taped advertising (in support of the station operations) From this "budget satellite fed relay" the next step up is to add local programming ability, first from tape or hard drive storage, then from a live presentation studio.

In most regions a UHF transmission channel will be required and FTN has been successful in working out a channel search and licensing procedure that allows new stations to be licensed rather quickly.

For SPACE members, there is a ground floor opportunity to become an owner or part owner as well as builder and operator of an FTN affiliate station. There are no "franchise fees" or other burdensome requirements - all it requires is a dedication to the concept and a willingness to put in the hundreds of hours that will be necessary to turn the concept into reality. As of early February, ten such communities are represented in the "Future FTN Affiliate" roster as local groups put together their financing and planning to create a local TV station.

And outside of New Zealand? Each country has its own licensing rules for new TV outlets. Members beyond NZ are

encouraged to visit with your national licensing authority to learn just what is required of you to construct a new television station. FTN programming, by being oriented towards "family values," should present minimal problems to licensing authorities who are concerned about the inflow of "objectionable content" programming. Remember - the concept is that each station will create a local forum for issues of interest to that specific geographic (coverage) region and the satellite fed network programming is essentially an "escape valve" to ensure each station access to "family values" television around the clock when local programming is not possible or economic.

Getting Started As An FTN Affiliate

- 1) Call and talk with FTN's Trevor Yaxley (tel 64-9-425-4054)
- 2) Ask for FTN's "So You Want to Launch A Family Values TV Station" package
- 3) Ask for off-air tapes from FTN to illustrate to you how FTN programming looks
- 4) Talk the concept up with people in your region to seek out financial backing (while NZ\$25,000 will do a bare bones station with 10 km coverage, we suggest you hold off establishing a financial goal until you have accurately surveyed the size of your market - you may wish to start with higher power than 10 watts)
- 5) Start looking for a local transmitter site!

FILTERS FOR CABLE TV YEAR #30**

Our catalog has a filter for every CATV problem.

Ask for it!

We can also make your special filter in a hurry.

Just tell us your problem. We'll answer within 24 hours!



Emily Bostick
President

Emily Bostick

**** Emily & Glyn Bostick - Continuing a generation of personal service to TV INDUSTRIES WORLDWIDE!**

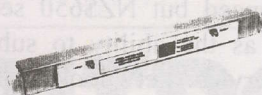

VHF

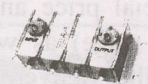

UHF

BANDPASS FILTERS



SATELLITE INTERFERENCE FILTERS



CATV DIPLEXERS



PAY-TV TRAPS



BROADCAST INTERFERENCE FILTERS

BOSTICK FILTER DIVISION

7395 Taft Park Drive
East Syracuse, NY 13057
Mailing address:
PO Box 3307
Syracuse, NY 13220
Tel: (315) 452-0709
Fax: (315) 452-0732
Canada & US: 800-882-1587



Contact Our Distributors:

MASER: Australia: Telephone: - 61 2 415 2877
Telequipment Pacific Ltd.: New Zealand: Telephone: - 64 4 384 1927

SatFACTS Pacific/Asian Region Orbit Watch: 15 February 1997

Copyright 1997: SatFACTS, PO Box 330, Mangonui, Far North, New Zealand (Fax: 64-9-406-1083)

Free-to-Air 57E to 80E	
Sun Music	57E/703 1400RHC
Sun Movies	57E/703 1342RHC
Sky News	57E/703 1257LHC
BBC World	57E/703 1224LHC
Sun TV	57E/703 1220RHC
AsiaNet	57E/703 1170RHC
WorldNet	57E/703 1100RHC
NEPC	57E/703 1090/LHC
TVi	57E/703 1020LHC
Muslim TV	57E/703 975LHC
Discovery	68.8/Pas4 Vt/1365
ABN	68.8/Pas4 Hz/1365
CCTV4	68.8/Pas4 Vt/1314
Sony Enter. TV	68.8/Pas4 Hz/1240
Doordar. India	68.8/Pas4 Vt/1116
CNNI	68.8/Pas4 Hz/1065
TNT/Cart.	68.8/Pas4 Hz/1040
ATN	68.8/Pas4 Vt/972
BBC World	68.8/Pas4 Hz/1350
MTV Asia	68.8/Pas4 Hz/965
TK Rossija	80/S13 1475RHC
VTV4	80/S13 1275RHC

Free-to-Air 80E to 113E	
AST	85/S3 1275RHC
Dub'l II	90/S6 1475RHC
Orbita II	90/S6 1275RHC
Dub'II I	90/S6 1234RHC
Orbita I	90/S6 1208RHC
Doordar.7	93.5/In2b 1285/Vt
Doordar.1	93.5/In2C 1160/Hz
Doordar.9	93.5/In2c 1080/Hz
Doordar.8	93.5/In2b 1050/Vt
Doorda10	93.5/In2b 1010/Vt
Doordar.2	93.5/In2e 980/Hz
Orbita II	96.5/S14 1475RHC
CCTV4	96.5E/S14 1325RHC
TV Shopping	100.4/As2 1490/Vt
TV Mongolia	100.4/As2 1470/Hz
5 China MPEG-2	100.4/As2 1430/Hz
5 China MPEG-2	100.4/As2 1310/Hz
CCTV4	100.4/As2 1190/Hz
RTPi	100.4/As2 1170/Vt
EBB (DVB)	100.4/As2 1150/Hz
Dub'l II	103/S21 1475RHC
ART	103/S21 1275RHC
CFI	113/C2 990/Hz
SQTV	113/C2 970/Vt

Free-to-Air 113E to 145E	
Brunei	113/C2 1010/Vt
MTV Asia	113/C2 1030/Hz
TPI	113/C2 1070/Hz
TV Indosair	113/C2 1090/Vt
ABN	113/C2 1120/Hz
ANteve	113/C2 1130/Vt
CNNI	113/C2 1183/Hz
GMA	113/C2 1230/Hz
TV3	113/C2 1250/Vt
ATVI	113/C2 1270/Hz
TVRI	113/C2 1310/Hz
RTM	113/C2 1330/Vt
RCTI	113/C2 1408/Vt
CNBC	113/C2 1530/Hz
Colour Bar Tests	128/Jcsat3 1170/Hz, 12.280/Hz 12.386/Vt
Orbita-I	140/S7 1475RHC
NTV	140/S7 1425RHC
Music Asia	142.4/R42 1475LHC
RAJ-TV	142.4/R42 1425LHC
Laos TV	142.4/R42 1375LHC
ViJay TV	142.4/R42 1325LHC
EM TV	142.4/R42 1272LHC
Dub'l-I	145/S16 1275RHC

Free-to-Air 145E to 180E	
CNNI	168/Pas2 1183/Hz
CNN Feeds	168/Pas2 1155/Hz
NHK	168/Pas2 1114/Hz
TV Shopping	168/Pas2 1400/Hz
Feeds	174/1701 984RHC
Feeds	174/1701 973RHC
Feeds	177/1702 984RHC
Feeds	177/1702 963RHC
Feeds	180/1511 1430RH
WorldNt	180/1511 1175RH
RFO	180/1511 1105RH
Feeds	180/1511 1020LH
Feeds	180/1511 984RHC

ENCRYPT/MPEG SERVICES

Sky Racing(a)	100.4 1130/Vt
European Bouquet	100.4 1150/Hz
Star TV (b)	100.4 1250/Vt
APTV (b)	100.4 1351/Hz
WTN (b)	100.4 1363.6/H
Star Chinese (a)	100.4 1390/Hz
Rebar TV (c)	100.4 1410/Vt
Star TV (c)	100.4 1450/Vt
ESPN (d)	113/C2 1030/Hz

HBO Asia (d)	113/C2 1150/Hz
TNT + (d)	113/C2 1390/Hz
Discovery (d)	113/C2 1430/Hz
Star Indovis'n (c)	113/C2 1570/Hz
Star Indovis'n (c)	113/C2 1650/Hz
Galaxy (c)	156/B3 12.437Hz
Galaxy (c)	156/B3 12.373Hz
China PowRvu (b)	168/Pas2 1433.5/ Vt
HK MPEG 1.5 (c)	168/Pas2 1426/Hz
Discovery (c)	168/Pas2 1374/Hz
ESPN (a)	168/Pas2 1288/Vt
California PowRvu (b) (c)	168/Pas2 1249/Hz
TNT + (a)	168/Pas2 1218/Vt
Fox/Prime (c)	168/Pas2 1161/Vt
Filipino Ch. (b)(c)	168/Pas2 1060/Hz
NBC HK	168/PAS2 1057/Vt
HK PowRvu (b) (c)	168/PAS2 1002/Vt
TCS Singapore (b)	168/Pas2 967/Hz

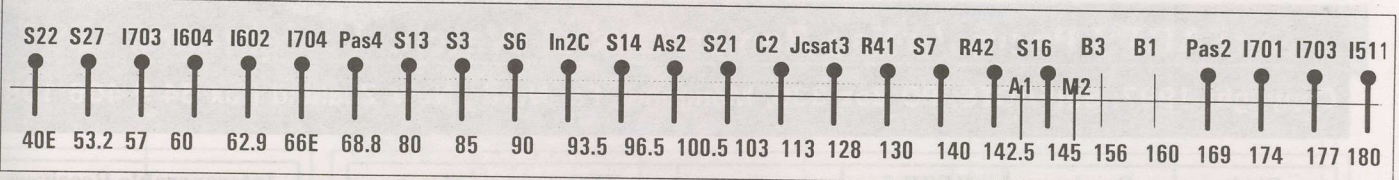

**OPTUS B3
156E
(Ku only)**

(B-Mac)	1425/Vt
Central ABC HACBSS	1393/Hz B-Mac 12693
Vic. ETV	1361/Vt CryptV. 12661
Imparja TV (B-Mac)	1329/Hz B-Mac 12577
Net 9, Sky specials	1233/Vt B-Mac 12533
Central ABC HACBSS	1201/Hz B-Mac 12561 1169/Vt
Galaxy	1137/Hz Irdeco Mpeg 2 12437 1105/Vt
Galaxy	1073/Hz Irdeco Mpeg 2 12323 12341
Golden West	1041/Vt 12309 1009/Hz 12277 977/Vt

RUSSIAN Inclined Orbits

80E/ +/- 2.3
85E/ +/- 2.8
96.5E/ +/- 1.5
103.2E/ +/- 2.1
130E/ +/- 1.0
140E/ +/- 4.4 (?)
142.4E/ +/- 0.9E
145E/ +/- 3.9

Encrypted (to left)

**OPTUS B1
160E
(Ku only)**

Net 9, Sky feeds	1425/Vt B-Mac 12702 1402/Hz
QSTV	1377/Hz B-Mac 12677
NE ABC HACBSS	1370/Vt B-Mac
NE SBS HACBSS	1344/Vt B-Mac
SE SBS HACBSS	1339/Hz B-Mac 12639
SE ABC HACBSS	1313/Hz B-Mac 12613
NZSky Channel	1296/Vt B-Mac 12596
ABC Radio	1276/Hz (digital) 12576
OmniCast	1270/Vt (FM/FM) 12570
ABC feeds	1247/Hz Pal 12547
Sky Nz (April 1)	1232/Vt VidCrypt 12532
Net 9 feeds	1219/Vt Pal & Nisc 12519
Net 10	1214/Hz 12514 1182/Vt E-Pal 12482
Net 9	1180/Hz E-Pal 12480
Net 10 feeds	1155/Vt Pal 12425
Net 7	1120/Vt E-Pal 12420
Net 9 feeds	1091/Vt Pal 12391
CAA air to ground	1009/Vt Ndbm 12309

**PAS-2
169E
(C + Ku)**

CCTV3,4	1433.5/Vt (Sa9223) 12725
Value Ch.	1400/Vt
Discovery PowerVu	1374/Hz (Sa9223) 12670
ESPN	1288/Vt B-Mac 12644
MPEG-2 PowerVu Sylmar	1249/Hz (Sa9223)
TNT+ (1/2Tr)	1218/Vt B-Mac
CNN+ (1/2Tr)	1183/Hz
FoxSports	1161/Vt (Sa9222) 12570
NHK	1115/Hz
Filipino Channel	1060/Hz (GI Mpeg)
NBC Mux MPEG	1057Vt (Pace)
MPEG-2 PowerVu HonKong	1002Vt (Sa9223)
TCS Sing.	967/Hz

PAS-2 Ku

Napa TC	12,415V
PowerVu	12,415V
H-Life	12,520V

**MeaSat 2
148E**

Tests	1167/Vt
-------	---------

**Intelsat 701
174E**

Feeds	963
Feeds	984

**Intelsat 703
177E**

AFRTS	973 (1)
Feeds	984

* LHC; (1) PowerVu (1 ch) operating

**Intelsat 513
177W**

Feeds	963
Feeds	984

(513 Ku)

Service	RF Freq.
US Nets	10.980V
NBC	11.015V
Feeds	10.510V

Ku Services
Intelsat Ku band services shown here are boresighted to Japan and nearby Asia, have not been reported south of equator. At boresight, signals of < 2m levels.

TDRS5 / 174.3W

Fuji TV	1305 Hz
BBC World	1163Hz MPEG

TDRS5 "north"

**Intelsat 511
180E(W)
+/- 2.9deg.**

TVNZ	964/Ntl 3000
TVNZ	972/Ntl 3000
TVNZ	980/Ntl 3000
TVNZ	988/Ntl 3000
Occ Vid.	1,020**
9 Aust.	1,025
Canal +	1,054 **
RFO Tahiti	1,105
Asian	1,130
World-net	1,175
NHK	1,225**
ABC Oz	1,256
7 Oz	1,274
10 Oz	1,385
MPEG (PwRvu)	
Keystone	1,432

* RHC & LHC
** LHC only

(511 Ku)

NHK	11.135H
CBS	11.475H
CNN	11.508H

(a) B-MAC or Starcrypt encrypted, no access available.; (b) MPEG format, requires special receiver; (c) MPEG, encrypted, access may be possible (d) B-MAC, subscriptions available in some geographic areas. No indication - MPEG DVB FTA.

UPCOMING SATELLITE LAUNCHES
February 25/ 11801 to 174E.

SatFACTS Pacific/Asian Region Digital Watch: 15 February 1997

Copyright 1997: SatFACTS, PO Box 330, Mangonui, Far North, New Zealand (fax 64-9-406-1083)

Bird	Service	RF/IF & polarity	# Programme channels	FEC	Msym	Interoperable Receivers (a)
As2/100.5E	European Bouquet	4000/1150 Hz	5TV, 12 radio (#1)	3/4	28(.125)	DVM, Gng, N163, N17X P400(b), P500, Pn520/630, Sk888
	?	3907/1243a Hz	?	?	?	
	Hubei TV Wuhan	3854/1296 Hz	1	3/4	4(.418)	N163, N17X, Ph3950/11
	Hunan TV Changsha	3847/1303 Hz	1	3/4	4(.418)	N163, N17X, Ph3950/11
	Guandong TV Guandong	3840/1310 Hz	1	3/4	4(.418)	N163, N17X, Ph3950/11
	Inner Mongolia TV Zizhiqu	3830/1320 Hz	2	3/4	8(.398)	N163, N17X, Ph3950/11
	APTV London	3800/1350 Hz	1	3/4	8(.448) or 5(.632)	DVM, N163, N17X
	BBC Radio London	3793/1357 Hz	15+ (?)	?	?	
	Worldwide TV News	3786/1364 Hz	1	3/4	5(.632) or 8(.448)	DVM, N163, N17X
	Liaoning TV Shevang,	3734/1416 Hz	1	3/4	4(.418)	N163, N17X, Ph3950/11
	Jiangxi TV Nanchang	3727/1423 Hz	1	3/4	4(4.18)	N163, N17X, Ph3950/11
	Fujian TV Fuzhou	3720/1430 Hz	1	3/4	4(.418)	N163, N17X, Ph3950/11
	Qinghai TV Lanzhou	3713/1437 Hz	1	3/4	4(.418)	N163, N17X, Ph3950/11
	Henan TV Zenghou	3706/1444 Hz	1	3/4	4(.418)	N163, N17X, Ph3950/11
As2/100.5E	STAR TV (Hong Kong)	3900/1250 Vt	5TV, 1Radio (#2)	1/2	28(.100)	DVM, N163, N17X
	?	3805/1345a Vt	?	?	?	
	Rebar TV Taiwan	3740/1410 Vt	4TV (#3)	3/4	18(.000)	Pv9223 (CA)
	STAR TV Hong Kong	3700/1450 Vt	5TV, 1 radio (#4)	3/4	28(.100)	Pace DVS-211 (CA)
C2/113E	Star Indovision	3500/1650Hz 3580/1570Hz	20TV (#5)	7/8	26(.850)	Pace DVS-211 (CA)
Ap1/138E	Reuters	?	1TV, data	3/4	5(.632)	
Optus B3/156E	Galaxy	12.438Hz 12.373Hz	20+ TV (#6)	3/4	29(.473)	Gng, P400, P500, Pn520, Pn630, Sk888 (c)
PAS-2/169E	Hong Kong PowerVu	4148/1002 Vt	8TV (#7)	3/4	29(.473)	Pv9223 (some FTA)
	NBC Hong Kong	4093/1057 Vt	7TV (#8)	3/4	30(.800)	Gng, N163, N17X, P400, P500, Pn520, Pn630, Sk888

Measur - RF/IF - 30msym + 7/8 -

3785

12.470

30(.800)

Melbourne 148E JMDRA SUC

12.284
12.346

20TV

7/8

30.000

SatFACTS Digital Watch: 15 February 1997 ♦ Support Data

Bird	Service	RF/IF & Polarity	# Programme channels	FEC	Msym	Interoperable Receivers (a)
PAS-2/169E	Ku California PowerVu	12415/1115 Vt	7TV (#9)	3/4	30(.800)	Pv9223 (some FTA)
	CCTV China PowerVu	3716.5/1433.5 Vt	3TV (#10)	3/4	19(.850)	Pv9223 (all FTA)
	TCS Singapore	4183/967 Hz	2TV (#11)	1/2	6(.620)	Pv9223 (occasionally FTA)
	California PowerVu	3901/1259 Hz	7TV (#9)	3/4	30(.800)	Pv9223 (some FTA)
	Discovery Singapore	3776/1374 Hz	7TV (#12)	3/4	19(.850)	Pv9223 (occasionally FTA)
1703/177E	AFRTS	4177/973 LHC	1TV	?	?	Pv9223

BOUQUETS: 1) European Bouquet. (1) Deutsche Welle, (2) MCM, (3) RAI International, (4) RTVE, (5) TV5 Paris; Radio (1) DW#1 stereo, (2) DW#2 (stereo), (3) DW#3 (stereo), (4) YLE (left), RCI (right), (5) SRI (l), WRN (r), (6) REE, (7) DW#1 (stereo), (8) DW#2 (stereo), (9) DW#1 (stereo), (10) NN RA6, (11) NN RA8 [+ MediaNet within lines 6-11 of VBI of DW TV]; 2) STAR TV Hong Kong. (1) STAR + Japan (NTSC), (2) says 'CNBC' but is test, (3) horse racing feeds very occasional to 'TCNA' Australia, (4) Sky News London, (5) Star Radio (test). 3) Rebar Taiwan. (1) "U1", (2) "U2", (3) "U3", (4) Channel 4. 4) STAR HK. (1) Star Movies SEA (661), (2) Star Chinese Channel (660), (3) NBC (658), (4) CNBC (657), (5) Sky News (655), (6) Viva Cinema (654). 5) Indovision. (1) HBO, (2) Star Movies SEA, (3) Film Indonesia, (4) MGM Gold, (5) ESPN, (6) Star Sport, (8) Channel V International, (9) Channel V Asia, (10) RCTI, (11) Star Plus, (12) Discovery, (13) Star Movies & NBC, (14) Phoenix Chinese, (15) CNN, (16) BBC World, (17) CNBC, (18) Cartoon + TNT, (19) Preview 1, (20) Preview 2. 6) Galaxy - presently 17 channels. 7) Hong Kong PowerVu. (1) CTN News, (2) CTN Entertainment, (3) TVBI HK and other feeds (NTSC), (4) Ad-hoc (PAL), (5) Ad-hoc (NTSC), (6) ABN, (7) CTN II, (8) CTN III. 8) NBC Hong Kong. (1) CNBC, (2) NBC time shift, (3) NBC Asia, (4) Colour bars - occasional feeds, (5) CNBC Mandarin, (6) NBC Asia time shift, (7) Colour bars. 9) California PowerVu. [Note: Ku band listing may not be operating at this time; programming identical to C-band.] (1) CMT (NTSC), (2) CBS feeds, others (3) NBA feeds, others, (4) EWTN (NTSC), (5) BBC World (NTSC), (6) Bloomberg Financial (NTSC), (7) Golf Channel (NTSC). 10) CCTV China. (1) CCTV4 (NTSC), (2) CCTV3 (NTSC), (3) CCTV tests. 11) TCS Singapore. (1) TCS, (2) TCS [repeat]. 12) Discovery. (1) Disc. Aust/NZ, (2) Default, (3) Disc. Japan, (4) Disc. SE Asia, (5) Disc. Taiwan, (6) Disc. Philippines, (7) Disc. China. PowerVu **bold face** listings are typically (not always) FTA.

Explanations: (a) Interoperable. Receivers which through repeated use have been shown to access services listed without aid of special computer software or non-standard "tricks." (b) PACE DGT400, others normally employed with Australia Galaxy service. Galaxy routinely "upgrades" over air the decoders with new operating software. If a Galaxy receiver is upgraded to include programme content "rating" software, receiver will no longer function on EBB (et al) services. (c) Galaxy service receivers - require Galaxy issued smart card to access pay TV services. (CA) indicates only conditional access programming on this transponder.

MPEG-2 DVB COMPLIANT RECEIVERS: [Note: This material is gleaned from readers, conversations with suppliers, Web Site postings. We believe it to be accurate but assume no responsibility for errors that appear. Individual dealers not listed, only prime importer/supplier.]
 DVM (NTL) 3000: Skandia Electronics (61-3-9819-2466)
 Gng Grundig DTR1100: Av-Comm Pty Ltd (tel 61-2-9949-7417)
 N163 Nokia V1.63: [Late February/early March] G & G Imports (61-8-8941-8860) and Telsat Communications (64-6-356-2749)
 N17X Nokia V1.7X (last number varies): OPAC (tel 61-2-584-1233)
 P400 Pace DGT-400: Through Galaxy offices in Australia
 P500 Pace DVR-500: Bay Satellite TV (64-6-843-5296)
 Pn520 Panasat 520: OPAC (61-2-584-1233)
 Pn630 Panasat 630: Antares Satellite (61-7-3205-7574)
 Pv9223 PowerVu D9223 [not DVB compliant] (from stock): Telsat Communications (64-6-356-2749)
 Sk888 Skandia SK888: Skandia Electronics (61-3-9819-2466)
Promised next 30 days:

Model Source (tel) MSYM does 3-31? SRC? Does FTA PV? Does AVAT NBC?

At Av-COMM, a receiver that does "everything" (translation: similar in operation perhaps to Nokia).
Promised next 60 days:
 At Kristal Electronics (Townsville, Qld. - 61-77-791-565) model KR100 Plus doing Msym 4 to 45 and both PAL and NTSC video PowerVu FTA signals.
Mystery Receiver:
 Samsung demonstrated quietly in February to "select" distributors that did PAL format PowerVu as well as DVB Compliant channels.
Coop's Fearless Forecast::
 Before April is over we predict there will be at least two receivers in market that "do" both DVB MPEG-2 services AND PowerVu FTA. The ONLY reason you will consider a D9223 after that date is because your customer demands access to one of the PowerVu conditional access, subscription available, services.

WITH THE OBSERVERS

AT PRESS DEADLINE

Sagem DVB MPEG receiver being shown in Pacific receives full range of Msym rate services (from Chinese to NBC) as well as PAL video format PowerVu according to reports from dealers who were shown unit operating early in February. We get closer to "everything in one box" each week!



COUNT THE DISHES. Rear of Sky Network (NZ) where various size, shape, models and brand Ku-band dishes have been undergoing test preparatory to selection of hardware suppliers for new Sky Ku-Direct service scheduled for April 1 launch on Optus B1, transponder 5 in Videocrypt analogue.

Confirmation of the identity of the nine separate Chinese uplink sites, and the programming they are supplying through AsiaSat horizontal transponders 3 and 6 headlines this month's observation reports - although very few observers presently have the required MPEG receiving equipment to tune-in these transmissions. The explosion in MPEG services leads directly to our expanded "Digital Tuning Parameters" section (pages 26 - 27 this month) and points up the likelihood that as the migration to MPEG accelerates during the coming months this segment of SF will grow correspondingly.

Those familiar with CCTV4 programming, day parts in English will find the "provincial" TV programming spread through the various SCPC (single channel per carrier) refreshingly different. Each of the nine provinces operating its own regional TV centre makes individual programme selection decisions. Some, like Guandong and Henan which were previously on FTA analogue before the conversion to MPEG (both are now SCPC), rely extensively on out-of-China broadcasting sources for sport events. Others generate regional Chinese sport which you will not find on any other satellite services. A few use American and European programmes you will recognise dubbed into Mandarin or a local dialect. Bottom of screen captioning is little seen. The full extent of this new wealth of programming is still being explored and a shortage of receivers capable of tuning in these broadcasts will improve dramatically by 1 April which will in turn provide more viewers with sufficient viewing time to

form a better grasp of the true content of the many new channels. Those who acquire receivers capable of doing the Chinese - check for separate radio channels (typically TV programme audio on left, separate radio on right).

Laos TV, formerly located on Rimsat R41 (130E) appeared without warning on Rimsat R42 (142.4E) February 1st. The transponder is Russian 10, the same as was used on R41. On R42, this transponder is widely seen from the central Pacific west through much of Australia with a signal level that is nearly identical to EM TV (same satellite). EM TV (IF 1275+/-), Laos TV (IF 1380 +/-) and Asia TV Net (IF 1475 +/-) form a three channel "cluster" for viewers over a wide area. Some observations: Laos begins the normal evening schedule at 1100UTC (12 midnight NZ, 10PM Sydney) but is usually on the air earlier with a daytime schedule as early as 0300UTC. Some observed daytime programming includes sport (tennis, soccer) which it seems to be acquiring outside of Laos. "Worldnet" programming, dubbed into Laotian with the background English track is seen some days as well. The Laotians appear to be doing their own unlinking, and you can watch them "acquire" the drifting R42 bird by sweeping their uplink back and forth (while, we assume, they watch the downlink to see when they are peaked), especially at sign on (both day part segments). If you switch back and forth between Laos, EM TV and Asian Net it will surprise you how often one or two of the three is doing a poor job of satellite tracking. Your dish may be tracking the moving R42

WITH THE OBSERVERS: Reports of new programmers, changes in established programming sources are encouraged from readers throughout the Pacific and Asian regions. Information shared here is an important tool in our ever expanding satellite TV universe. Photos of yourself, your equipment or off-air photos taken from your TV screen are welcomed. TV screen photos: If PAL or SECAM, set camera to f3.5-f5 at 1/15th second with ASA 100 film; for NTSC, change shutter speed to 1/30th. Use no flash, set camera on tripod or hold steady. Alternately submit any VHS speed, format reception directly to SatFACTS and we will photograph for you. Deadline for March 15th issue: March 5 by mail (use form appearing page 34), or 5PM NZST March 5th if by fax to 64-9-406-1083.

perfectly, but the same cannot be said for all three of the uplinkers: Seldom will all three be hitting the bird "perfectly" at any given moment in time (i.e., the quality of each signal will vary through the bird independent of the others). Laos TV can be entertaining and informative, far "softer" in content than the typical Asian material we are accustomed to viewing on satellite. Check it out.

Additional MPEG signals. One of the advantages of having a suitable spectrum analyser handy is the ability to "spot" MPEG signals quickly. It won't tell you who they are, or the precise frequency but you are at least alerted to their presence (see photos, p. 15). Within the AsiaSat 2 service there presently appears an unknown SCPC MPEG at approximately IF1243 Vt and another at IF 1345 Hz. The 1243 signal has an almost identical analyser "signature" to the Chinese.



Southstar Media's Ken Clark (l) visiting with Johannes Firsbach (DW) which Southstar represents in the region.

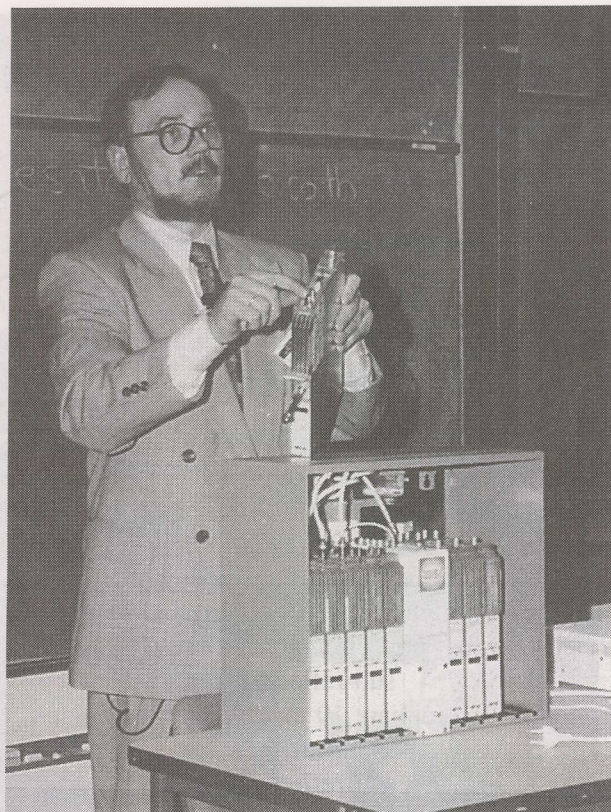

Bernrd Pawlik, WISI - Germany, describes the technology underpinning distribution of the satellite IF band (950 - 2,150 MHz) in an SMATV environment. WISI is now represented in region by Telsat Communications.

As a SatFACTS subscriber - YOU CAN WIN ONE OF THESE!

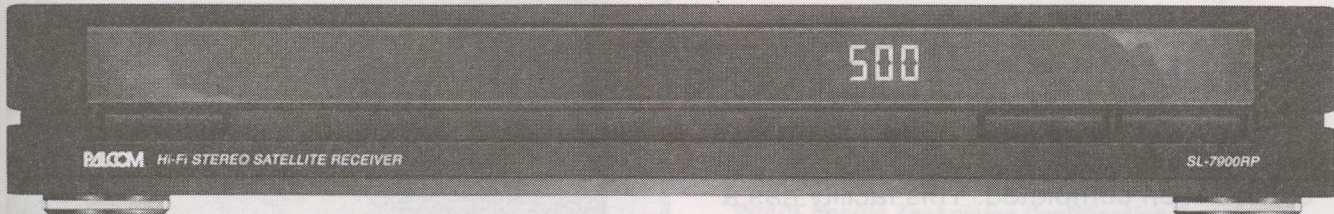

IT "LAUNCHES" IN THIS ISSUE - the 1997 SatFACTS Subscriber Contest. We will be giving away TWO brand new Palcom SL7900RP Hi-Fi Stereo Satellite Receivers - acclaimed the most versatile super low threshold "enthusiast" receiver in the Pacific & Asia.

How do you enter to win???

- FIRST** - you MUST register with SatFACTS as a contest entrant. How do you do that? See perforated card (page 34) in this issue - complete this card and return to SatFACTS.
- SECOND** - you will be mailed full contest rules as our acknowledgement of your registration.
- THIRD** - read (very carefully!) this issue (SF30) for clues leading to your first formal contest entry.

P
A
C
I
F
I
C

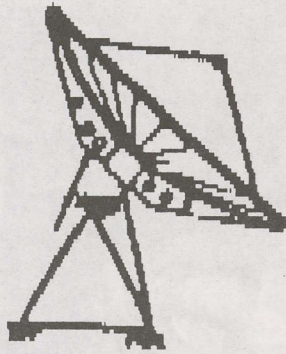

Limited

A
N
T
E
N
N
A
S

New Zealand's only stockist of preused transmit capable antennas - our stock presently consists of the following equipment:

- 1 only 2° compliant 13 metre standard 'B' Vertex antenna with 4 port circular feed and Cassegrain sub-reflector
- 1 only 3° compliant 10 metre Scientific-Atlanta antenna with 2 port linear feed and Cassegrain sub-reflector
- 1 only 4.6 metre Andrew Ku Band antenna with 2 port feed and Gregorian sub-reflector
- 3 only 5 metre Sat Com Technologies transmit rated Ku band antennas
- 1 only 3.7 metre Comtech transmit antenna with Seavey transmit feed horn

A selection of receive and transmit electronics including tracking equipment and motor drives with 15 to 50 ton azimuth and elevation jack screws.

Pacific Antennas Limited is the major stockholder in New Zealand Teleport Holdings Limited, a teleport 90% construction completed. This facility has a standard 'B' 13 metre Vertex antenna with auto tracking capabilities. These companies can individually or collectively joint venture, lease, sell, operate or install all of the above equipment. We have the necessary licensing in place and the hardware has been installed for New Zealand's first privately owned independent standard 'B' uplink teleport. To learn more about business opportunities available, contact **Bryon G.G. Evans.**

Pacific Antennas Limited

PO Box 265 • Whangaparaoa (Auckland), NZ
Tel/fax 64-9-424-0841 / Mobile 025-789-160

SatFACTS February 1997 ♦ page 30

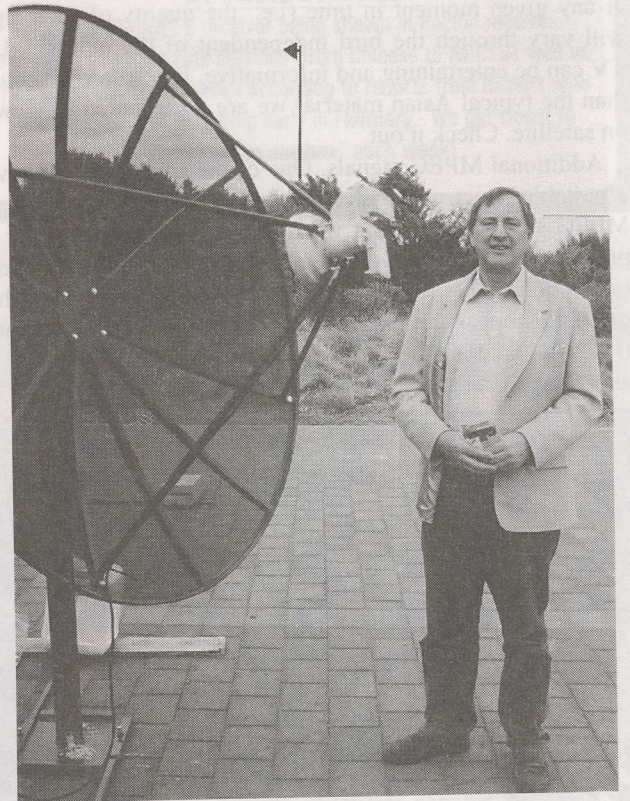

JIM HODGETTS - TV5 Paris's man for the Pacific and India during SPRSCS '97. Hodgetts has pushed especially hard to encourage MPEG-2 receiver suppliers to come to the "EBB Party."

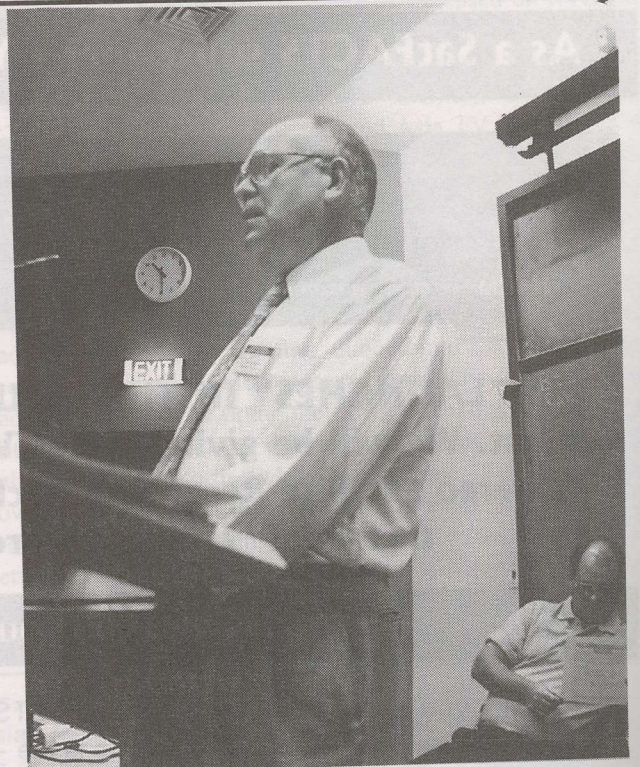

"Identify your market" was the SPRSCS message from Skandia Electronics' Leon Senior. Leon has believed in the analogue to digital transition from the outset and his SK888 was the first consumer priced unit to appear in the marketplace; well done Leon!

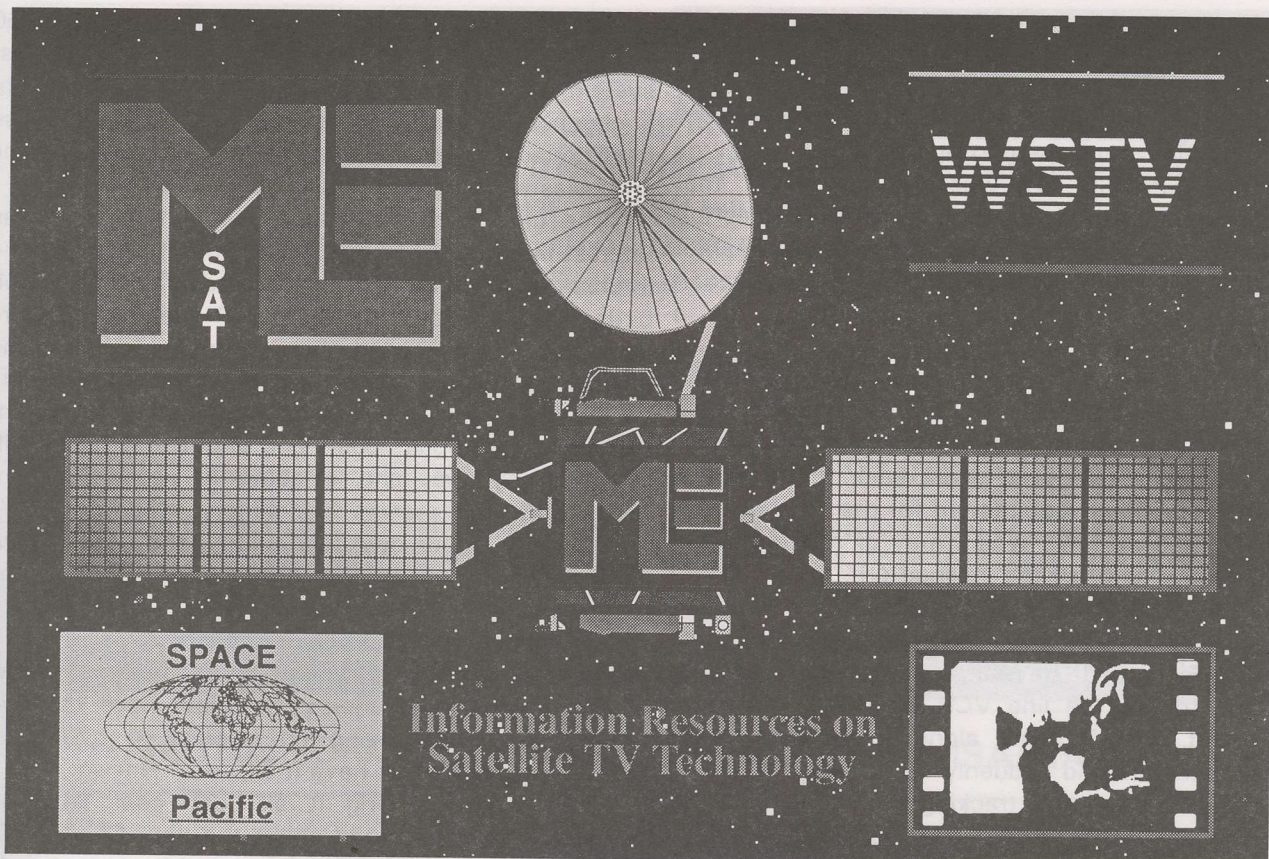

<http://www.cm.ksc.co.th/~mlesat>

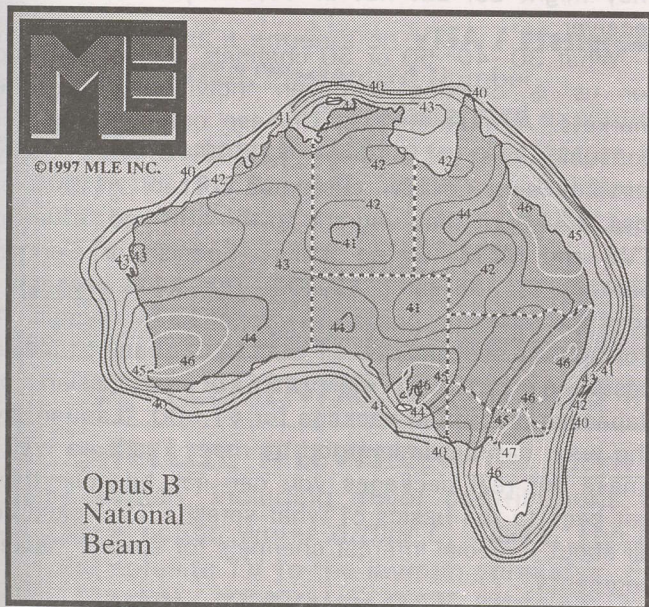

MLE/Shelburne Films *Satellite Series Videotapes*
The View from Chiang Mai:

The latest observational satellite TV transponder data for the Asia/Pacific Region.

Satellite TV Archives: Recent articles on satellite TV technology by Mark Long

Worldwide Satellite Web: links to Internet Web Sites of interest.

SPACE Pacific Technician Certification Course

Excerpts from satellite technology textbooks

Graphics and other educational resources

E-mail link to the author

Come see us at:

<http://www.cm.ksc.co.th/~mlesat>

Published by:

MLE (Thailand) Co. Ltd.

124 Chang-klan Road #110

Chiang Mai 50300 Thailand

One of the more perplexing off-stage concerns permeating SPRSCS '97 was the agreement that Australian ethnic markets aside, home dish sales are simply not doing very well. The enthusiast market (people - most of whom read this publication religiously each month) has turned out to be a non-growth market for New Zealand, much of Australia and even in the TV starved regions of the Pacific. There are several possible reasons for this - none proven and perhaps none accurate in analysis.

Four years, even three years back, there was a simplistic equipment requirement for the "enthusiast": A dish pointed at 180E which may or may not have had the ability to track the inclined orbit of an ageing Intelsat. Av-COMM, others, sold these do-it-yourself systems for under \$1500 in local currency. With this a fellow or gal could "have a play" for about the cost of a new top of the line VCR. Then life got more complicated. PAS-2 came along followed by one, then two Rimsats and suddenly the enthusiast felt he had to have orbital arc tracking and a complicated feed system to compensate between left and right hand circular, vertical and horizontal linear polarities. The price of an enthusiast package shot up. But before that could take root, PAS-2 started hitting us with the early versions of digital TV and suddenly it cost \$3,000 in local currency just to own the SA D9222 receiver. Now the enthusiast who wanted "everything" was facing a \$5-6,000 price tag.

If that wasn't a serious damper, along came AsiaSat 2 in December 1995 and before most could assimilate what that meant for business, Palapa C1 launched. The brief euphoria that accompanied the super strong but geographic limited coverage of the various C1 transponders faded when we realised the satellite was "sick" and would be replaced by C2. Add to this the slow deterioration of EM TV (followed by their deployment of scrambling), the loss of RAJ and by the latter quarter of 1996 you had a very confused marketplace.

Which as an industry we further muddied by our widely publicised reports that MPEG-2 DVB Compliant was anything but - compliant or a standard. Is it any wonder that enthusiasts - people interested for the sake of exploring all that satellite has to offer - suddenly lost interest in what we had to show or sell them? We wanted more channels because we believed more would help us sell systems. What we got is a hodge podge of standards requiring a stack of receivers, a pair or worse of LNBs, an antenna feed that has yet to be perfected, and a pile of receivers each 'good only' for one or two services. A real enthusiast could spend \$15,000 in local currency and still not have it all. That is a 1000% increase in "entry level pricing" from just three years back.

That you now can access 30-40-50 - even 60 different programming channels with an enthusiast system (which compares very favourably to the 4 or 5 channels three years back) is impressive but also bewildering to the present generation of wanna-be enthusiasts. Be careful what you wish for ...

The general public, those people who show an interest in owning a satellite system but who have no interest nor reason to chase Russian inclined orbit birds just to "see what's there" meanwhile were being told they needed these horribly complex and difficult to operate systems just to "get into satellite TV." Faced with such an intimidating array of hardware, lacking a "point and shoot and watch" IR operating system, and a going in set-up cost of \$6-10,000, the market has simply evaporated. We are a victim of our own technology, the rash of new satellites, the total disarray brought to market by the programmers who seem bent on having their own, special, unique transmission "standards."

Individually we have become so enamoured with all of the programming choices we now have that we assume anyone showing an interest in owning a satellite system "must have it all, too." Not so.

Not when "having it all" can cost \$10,000 upwards. We get excited about the new Chinese TV channels - only those who speak Mandarin would share that excitement. We are excited by the European bouquet - the customers for it will watch one, perhaps two of the channels only. We think every Catholic is a customer for EWTN - and well they might be, but not at \$3,000 just for the SA receiver.

What 30 -40 -50 or 60 channels should be doing for us is creating a dozen individually separate markets. A multi-channel Chinese only package for consumer cost of perhaps \$2,500; a French only service using CFI for customer cost of \$1,500 or less, \$2,300 if they upgrade to the EBB and settle for TV5 and MCM. Or an Italian, Spanish or German package for the same \$2,300. The same package - sold for different purposes - to different people. A Portuguese package for \$1,500, an Egyptian (middle eastern origin) or Malaysian or Indonesian or Japanese or Laotian package for \$1,500. (Laotian, by the way, can be understood by most Thai's as well.) These are real packages you can sell because they get back to the basics of what satellite TV should be all about - special interest channels for special market segments.

Yes we have up to 60 channels to sell. No - most will not be of interest to more than a small percentage of consumers. And because you can sell these packages, installed, with fixed mounts, no actuator, and single pole feeds, the installs will be quick and profitable.

Do you want to make money in satellite? Forget about 60 channels and concentrate on 2 or 3! Only the enthusiast "wants it all" - and he probably can't afford what it presently costs anyhow.

THE YEAR OF SATELLITE EXPLOSION IN THE PACIFIC/ASIA!

THIS IS IT - "The Year" we have all been waiting for. NEW satellites, NEW programmers, NEW consumer-friendly MPEG receivers. Experimentation is winding down - NOW we get serious!

- ENTER my 12 MONTH subscription to SatFACTS starting with March 15th issue (rates below)
 ENTER my 36 MONTH subscription to SatFACTS starting with March 15th issue (rates below)

NAME _____
Company (if applicable) _____
Mailing address _____
Town/city _____ Country _____

Amount to send: 1 year - NZ\$50/A\$90/US\$50 (outside of NZ and Australia) or 3 years - NZ\$120/ A\$210/ US\$120 if by cheque. **VISA or Mastercard?** See form below and return with order. Return to: **SatFACTS, PO Box 330, Mangonui, Far North, New Zealand** or if by VISA or Mastercard fax to 64-9-406-1083

ALL SatFACTS SUBSCRIPTIONS ARE SENT VIA AIRMAIL - WORLD-WIDE!

USE THIS FORM ONLY WHEN CHARGING ON VISA/MASTERCARD

Please charge my **VISA/Mastercard** as follows:

- ONE Year of SatFACTS MONTHLY (NZ\$50, A\$90, US\$50)
 THREE Years of SatFACTS MONTHLY (NZ\$120, A\$210, US\$120)
 SATELLITE TELEVISION: The Booklet (NZ\$10, A\$12, US\$10)
 One Year of COOP'S TECHNOLOGY DIGEST (NZ\$125, A\$125, US\$125)

Indicate charge card type: VISA Mastercard

Name (as it appears on **VISA / Mastercard**) _____

VISA/Mastercard Number _____ - _____ - _____ - _____

VISA/Mastercard expiration date _____

Instructions: If ordering by mail, return this complete (3-part) card or a copy of same (to **SatFACTS, PO Box 330, Mangonui, Far North, New Zealand**); if order by FAX, send full card as a single sheet to **64-9-406-1083**

SUPPLEMENTAL MATERIALS from SatFACTS MONTHLY: Order Form

- SATELLITE TELEVISION:** The Booklet. Excellent introduction to home dish ownership for the layman, including major contributions from the father of geostationary satellites - famed science fiction writer *Arthur C. Clarke*. The perfect tool to help the satellite system seller explain home satellite TV to the layman consumer. From SPACE Pacific. NZ\$10/ A\$12 / US\$10, airmail.
- COOP'S TECHNOLOGY DIGEST.** For the really serious enthusiast, investor, business person in satellite television and allied leading edge technologies. Ten issues each year, jam-packed with information you will not find anyplace else. "Coop" routinely culls more than 60 publications world-wide, terribly expensive newsletters, Internet and his hundreds of private contacts to keep you right at the leading edge of technology on the REAL changes underway in telecommunications. Conveniently issued near the **first of the month**, creating an excellent time-line-filler between the mid-month issues of SatFACTS. Now in the 4th year, airmail world-wide. Normally NZ/A/US\$250 per year - for SatFACTS subscribers special **50% discounted** price of NZ/A/US\$125.

OBSERVER REPORTING FORM - CONTEST ENTRY - Due March 4

- NEW programming sources seen since February 1st: _____
- Changes (signal level, transponder, programming content) in pre-existing programming sources since February 1st: _____
- OTHER (including changes in your receiving system): _____

NOTE: Please use P1 - P5 code when describing signal levels and receiver IF/RF settings.

Your Name _____ Is this contest entry? _____
Town/City _____
Make/size dish _____ LNB _____ Receiver _____
Bonus Word Entry: _____ on page _____

MAIL TO: SatFACTS Monthly, PO Box 330, Mangonui, Far North, NZ or fax 64-9-406-1083

YOU COULD WIN A PALCOM SL7900RP! - REGISTER WITH THIS CARD

SatFACTS is giving away two (2!) top of the line super receivers - the PALCOM SL7900RP - to subscribers during the next 12 months! This is a MONTHLY CONTEST and you must REGISTER with us as a contest entrant. Complete this card to receive the full set of Contest Rules and join the fun. AN SL7900RP could well be yours (first receiver to be given away June 5!).

- I AM A SUBSCRIBER TO SATFACTS - Please mail to me my SatFACTS Reader Contest Rules!

NAME _____
Company (if applicable) _____
Mailing address _____
Town/City _____

Return card to: **SatFACTS Monthly**, PO Box 330, Mangonui, Far North, New Zealand
of fax to us at 64-9-406-1083

MEMBERSHIP IN SPACE?

Choose your level of participation from "Individual" or "Installer / Dealer" to "Cable/SMATV Operator" or "Importer/Manufacturer/ Programmer."

- YES - Send details of SPACE membership, to ...

NAME _____
Company (if applicable) _____
Mailing address _____
Town/city _____



SPACE Pacific Ltd.
PO Box 30, Mangonui, Far North
New Zealand
Fax 64-9-406-1083

**MPEG 2
DVB
FORECAST**

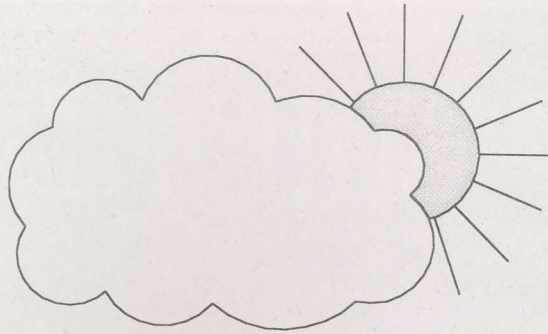

*Clearing -
bright and
sunny days
ahead!*

Courtesy of the NEW PANASAT
IRD 630 DStv

The Panasat IRD630 combines a high quality MPEG-2 DVB Compliant Satellite Receiver with an integrated sophisticated decoder in one compact package. The IRD provides all you require to exploit the exciting, new satellite services that are now available as well as those on the way!

This totally new Panasat IRD630 is here and ex-stock in Brisbane - AND - *very keenly priced!*

Included as "standard equipment" - new "Open Electronic Programme Guide" and new "TV Information Bar."

Elegant in performance, straight forward (even simple!) to set-up and use, dependable and best of all - it is available now and in stock!

**ANTARES
SATELLITE
PRODUCTS**

5, Navua Street, Strathpine, Qld. 4500
Phone/Fax 61-7-3205-7574

UNIDEN SATELLITE TELEVISION

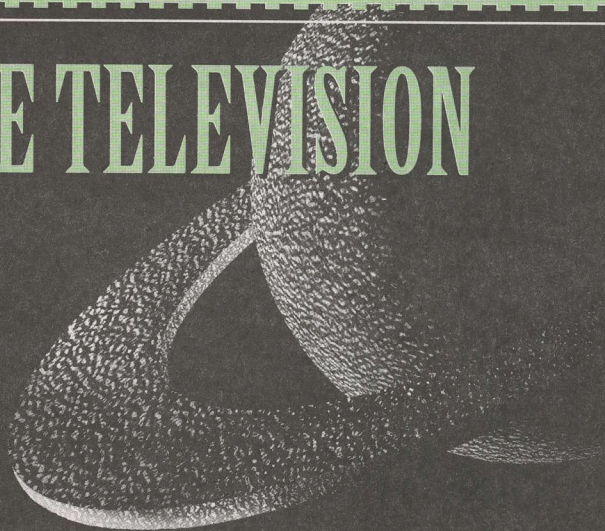

JUST IMAGINE...

Over thirty channels of free-to-air television from around the globe available throughout New Zealand. even in areas where present free-to-air or paid channels don't reach.

THIS IS NOT A DREAM, It's a reality. And it's available to your customers right now, with equipment costs that are probably a lot less than you would expect.

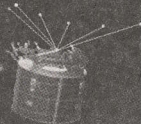

Uniden are about to launch their Satellite Television Package to dealers throughout New Zealand.

If you would like to find out how to profit from satellite television in New Zealand give Uniden a call.

After all, Uniden is one of the world leaders in satellite television technology.

UNIDEN SATELLITE TELEVISION

*Putting You Face To Face With
A World of Entertainment*

uniden®

a Clear Signal of What's Ahead

For more information Phone 0-9-273 8383 or Fax 0-9-274 0009

Uniden® is a registered trademark of the Uniden Corporation of Japan Ltd and is represented in New Zealand by Uniden (NZ) Ltd.