

12-12-96 9.15AM

Bob Cooper's

DECEMBER 15 1996

# SatFACTS

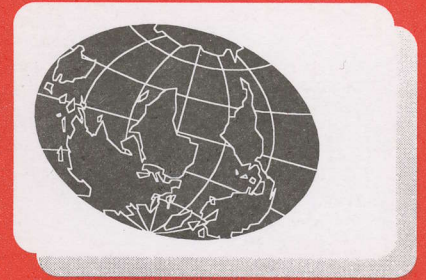

MONTHLY

Reporting on "The World" of satellite television in the Pacific Ocean Region

## IN THIS ISSUE

**NOKIA 9500 S  
(another OOPS!)  
+ SK888 Update**

**INTERNET  
and PowerVu  
UPDATES**

**ADVANCE  
DETAIL  
SPRSCS '97**

- ✓ Latest Programmer News
- ✓ Latest Hardware News
- ✓ Latest SPACE Pacific Reports
- ✓ Cable TV Connection

Vol. 3 ♦ No. 28

Price Per Copy:  
NZ\$8/A\$9/US\$5



# Paraclipse<sup>®</sup>



When quality, strength, and accuracy are your main requirements, **Paraclipse** antennas are your first choice.

Only **Paraclipse** offers such variety; four distinctly different series:

- the Truss-Ribbed Classic,
- the Courier Deliverable Eclipse,
- the Stretch Formed Hydro,
- the Commercial Patriot.

Every **Paraclipse** model sets the industry standard in its class, worldwide.

HYDRO  
SERIES

ECLIPSE  
SERIES

CLASSIC  
SERIES

Distributed in New Zealand by  
**Bay Satellite TV Ltd.** PO Box 14050 Hastings  
Tel: 64-6-878-9081 Fax: 64-6-878-5994

**Paraclipse<sup>®</sup>**  
HIGH PERFORMANCE ANTENNAS

Paraclipse Inc.  
2271 29th Avenue East, Columbus, Nebraska USA 68601  
Telephone: (402) 563-3625 FAX: (402) 564-2109

★ **MADE IN AMERICA**

# SatFACTS

## MONTHLY

SatFACTS Monthly is published 12 times each year (on or about 15th of each month) by Far North Cablevision, Ltd. This publication is dedicated to the premise that as we enter the 21st century, ancient 20th century notions concerning borders and boundaries no longer define a person's horizon. In the air, all around you, are microwave signals carrying messages of entertainment, information and education. These messages are available to anyone willing to install the appropriate receiving equipment and, where applicable, pay a monthly or annual fee to receive the content of the messages in the privacy of their own home. Welcome to the 21st century - a world without borders, a world without boundaries.

### Editor/Publisher

**Robert B. Cooper**  
(ZL4AAA)

### Office Manager

**Gay V. Cooper**  
(ZL1GG)

### Reaching SatFACTS

Tel: 64-9-406-0651

Fax: 64-9-406-1083

Mail: PO Box 330

Mangonui, Far North  
New Zealand

### Subscription Rates

Within NZ: NZ\$40 p/y  
Australia: AV-COMM Pty

Ltd, PO Box 225,  
Balgowlah NSW 2093  
61-2-9949-7417

Elsewhere: US\$40 p/y

### ERRATA

SatFACTS Copyright 1996  
by Robert B. Cooper; any  
form of copying is a  
violation of our  
international copyrights.  
Advertising rate sheet  
available upon request.

## COOP'S COMMENT

Sport and movies drive most satellite TV consumer packages but as some installers are learning there is considerable business available to anyone who focuses on the often uniquely satellite available speciality services as well. On December 9th here in the Pacific a new "special interest" programming channel launched on PAS-2 buried within the PowerVu MPEG-2 bouquet uplinked from California. A smart system seller will find customers for this service and most of the customers will not even blink at the still outrageous cost of an S-A D9223

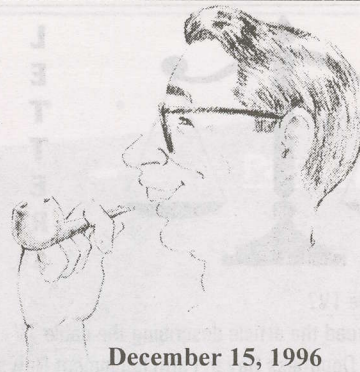

December 15, 1996



receiver. Eternal Word Television Network is the 'Global Catholic Network' originating near Birmingham, Alabama 24 hours per day. EWTN is mostly in English and yes, it is mostly Catholic dogma. But not totally and certainly not to the exclusion of

attracting non-Catholic viewers. The marketing opportunities should be self-evident. Every Catholic church, Catholic operated school, community centre used by religious groups and religious supply shops head the list. Individual Catholic families are a strong opportunity to sell a terminal as well.

EWTN is a 'link to Catholicism' which the scattered faithful have welcomed in the ten-plus years the network has operated. Mother Angelica, the nun in Alabama that conceptualised and brought the service to operation, is now widely acclaimed for her tenacity and creativity. She has done for Catholics what Ted Turner has done for news freaks.

The PAS-2 California link requires an S-A D9223 receiver. It is free to air and it will stay free to air. For most installs, a fixed dish with a single pole feedhorn connected to the D9223, followed by an NTSC to PAL standards converter will be the sum of the system. Inside the facility, there are likely to be multiple viewing locations and a tape deck or two for time shifting. This means you should be able to sell more than a D9223 based TVRO; a reasonably good modulator with a cable distribution system using line taps will also be required. To help you better understand the challenge, we outline the service on p. 32 in this issue.

For the cable system operator, EWTN is another English language TV channel which will have as much appeal as, say, The Golf Channel or CMT. (I feel comfortable suggesting there are more Catholics than Golfing buffs or Country music fans.) That the same D9223 could produce EWTN + CMT + The Golf Channel for a devoted country music loving Catholic 'Golf Nut', all from the same PowerVu California bouquet, means D9223 could be 'heavenly'.

EWTN is but the first of similar broadly based, splinter interest groups coming on line throughout the Pacific shortly. Put on a clean shirt and start making your sales calls.

### In Volume 3 ♦ Number 28

NOKIA 9500S & SKANDIA SK888 MPEG-2 Receivers -p.6  
Internet Via Satellite Update - p. 10; PowerVu Update - p. 11  
SPRSCS '97 Preview -p. 14; SPRSCS '97 Schedule -p. 18

### Departments

Programmer / Programming Update -p.2; Hardware / Equipment Update -p.4  
SPACE Notes: Tackling Dish Restrictions Head-On -p.20 ;  
The Cable Connection / Starting On a Shoe String 2 -p.22;  
SatFACTS Orbit Watch -p.24; MPEG-2 Tuning Parameters -p.26;  
With The Observers -p. 29; Programming Notes (EWTN) -p. 32  
December Reporting Form -p.33; SPRSCS '97 Reg Form -p.34

### -ON THE COVER-

No zoning or Council approval problems here! Enthusiast Todd Johnson (Camborne, Plimmerton, NZ) reports his 3m Paracclipse with ADL RPC-2, Norsat LNB and Palcom SL-7900RP receiver routinely provides several dozen FTA analogue channels. The subject of Council and Resource Management Act regulations inhibiting dish installs remains a sensitive topic elsewhere (see p. 20).

(Letters/ continued from p. 2)

In theory splitters that pass power through one port or all ports are identical in design; those that block power at some ports use a blocking diode to stop (DC voltage) powering. This makes the power pass / one port more expensive because they contain additional parts. Our experience has been that splitters sold in the TVRO world with power all ports are not as well designed and provide poorer match (an important element of splitter specs) than those that have the power block included. In short, power pass all ports is a 'red flag' that says "We did this the least expensive way possible." Given the tendency of many MPEG IRDs to react badly to mismatches (cable, connector, splitter or line amp created), it seems good sense to avoid "least expensive" splitters as a potential trouble spot. When using splitters, always (always) place a 75 ohm terminating resistor on unused ports. Ooops: Another reason to use power pass one port as a 75 ohm resistor terminating a port with power on it will "fry" quickly (and probably take the fuse in the receiver LNB power line with it).

#### ENTRY Level

"I have just finished reading the SPACE Satellite Television booklet; please enter my subscription to SatFACTS. It seems that Australian prices for satellite dish systems are less than in NZ; why is that?"

Christopher A. Wess, Christchurch

**Two reasons: Signal strength from satellites and different equipment sources. Australian Ku band service (Galaxy and others through the Optus satellites) requires a smaller dish (typically under 2m diameter). Unfortunately most of the Optus services (see p. 25, here) don't reach NZ and those that do require 3m or larger Ku-rated dishes. The AsiaSat, PanAmSat, Palapa and Rimsat/Gorizont satellites on C-band are stronger in most of Australia (but not all) than in NZ as well. Stronger signals = 's smaller dishes = 's lower pricing.**

#### A Matter of Attitude

"Thank you for sending me a notice reminding me my subscription to SatFACTS expired. I am sorry to tell you that I will not continue because there is no way to install a 12' dish in my backyard here in Christchurch. A Japanese couple was prosecuted for their installation. Perhaps in 100 years the local council will change their mind."

Francis Chang, Christchurch

**Christchurch may be getting a bad 'rap' for the way they have treated dish installs (see SF # 22, p. 19). See SPACE Notes.**

## HARDWARE EQUIPMENT PARTS

## UPDATE

DECEMBER 15, 1996

**California Amplifier** product shipments could be compromised following extensive resignations in November. Firm sales were buoyed by LNBFs sold in quantity to Australian Galaxy but competition from Cambridge and others has eroded that market. Most recent reports tell of fax and e-mail communiqués going unanswered, people who used to be there having left employment. Amongst those no longer on the roster, sales engineer extraordinary Bob Partain who did much to make SPRSCS '96 a memorable event. New Gardiner DBS LNBF units just introduced into North American market will further cut into sales; early reports say "Gardiner units play good and cost less than Cal-Amp equivalent models at distributor quantity level."

**Lord Howe Island**, off coast of NSW, discovered the joys of Galaxy DTH service during November. A 2.1m dish with a decoder shipped out from the mainland produced error free reception. The island has around 250 full-time inhabitants, is "protected" by regulations from additional growth, and is served by low power terrestrial transmitters rebroadcasting SBS and ABC. Much further out, New Caledonia reports near P5 reception with high quality 3m spun aluminium dishes on Galaxy and as many as 50 Galaxy units are scattered around New Zealand mostly on South Island and southern half of North using 3 to 5m dishes.

"**d-Box**" and other 1996 failures. Our report on tests of early Nokia 9500 S units to arrive in Pacific (p. 6) doesn't say it all. Two huge euro-conglomerates raced to be first in Germany with MPEG digital TV and Nokia agreed to supply "d-Box" IRDs to one of these, the Kirch Group. "d Box" is for DF1 service which German magazine Tele-Satellit reports had fewer than 3,000 subscribers after 60 days of operation. Not good if it is true as Nokia cranked out 90,000 "d-Box" IRDs in the same period. DF1 is counting on the Christmas season motivating Germans to purchase the new hardware (and software packages); alas, warehouses bulging with unsold receivers are looking for "unsuspecting" consumers outside of Germany to get the "digital craze." We warn you not to be in a hurry in our report; one Euro source tells us the Nokia must be version 1.719 to work on C-band. Meanwhile in South Africa MultiMedia's digital pay TV service has also bombed amidst increasing concern that the average TV viewer there simply cannot afford or will not pay several thousand Rand to have 20 channels of TV in his home (or mud hut). Business is not well in many MPEG IRD markets; our Coop's Technology Digest looks behind the headlines to analyse what went wrong in the December 20th edition.

**Source** for Skandia SK888 receiver is Sun Moon Star, a medium size Taiwanese firm in US\$500 million per year sales region. Actual receiver design done by Asia Digital Broadcasting (ADB) which was formed by ex-SGS-Thomson engineers to assist manufacturers in bringing MPEG-2 products to market. ADB uses SGS-T architecture and personnel were heavily involved in creating original MPEG chipsets. ADB is doing software design for several other "name brand" would-be entrants into MPEG-2 IRD market - if you like the SK888, you will recognise its basic design in numerous additional products to be released during 1997. Sun Moon Star may not be "medium sized" much longer!

**OOPS Department.** Europeans with "older 2.1 version software" Panasat or Pace Irdeto CA receivers have discovered they can access Dutch pay-TV service by simply tuning in, unplugging briefly the Irdeto-CAM, pushing it back in and the previously conditional access reception is suddenly available. Version 2.2 corrects this defect.

**AFRTS** now in test mode with PowerVu digital on 177E, first receivers in hands of Embassy sites in Pacific. Relevant (receiver set-up) numbers?

# ADL

BECAUSE PERFORMANCE IS ALWAYS YOUR FIRST PRIORITY

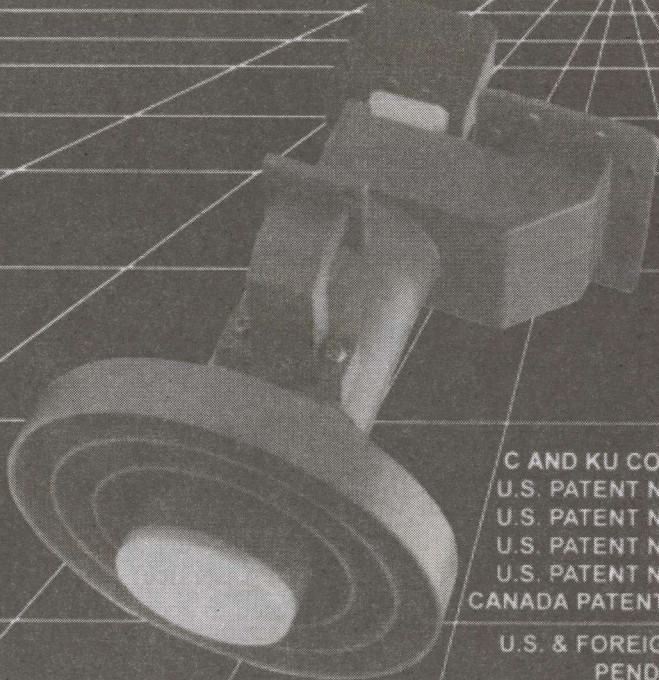

**RP3-CKU/ International  
Adjustable Scalar Ring Feed  
with Extended C Band**

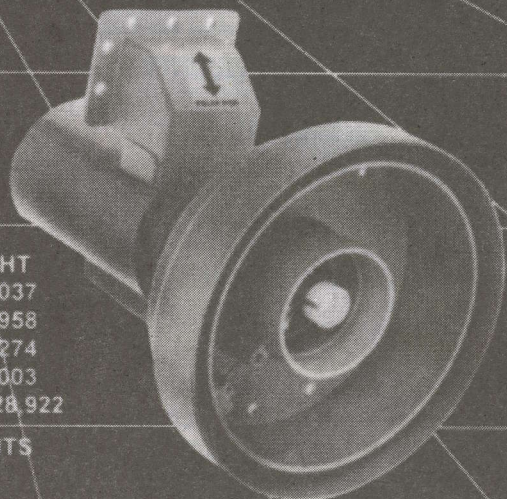

**RPI-CKU Feed**

C AND KU CO-BORSIGHT  
U.S. PATENT NO. 4,903,037  
U.S. PATENT NO. 5,066,958  
U.S. PATENT NO. 5,107,274  
U.S. PATENT NO. 5,255,003  
CANADA PATENT NO. 1,328,922

U.S. & FOREIGN PATENTS  
PENDING

## ADL HYBRID MODING CIRCULAR POLARIZED INTELSAT FEEDS WITH EXCLUSIVE T.I. REJECTION



**RP1-CP400**

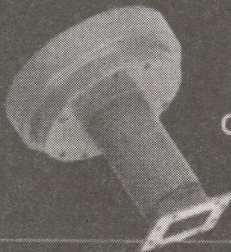

**CP-300**



**CPOR-100**

- C BAND LINEAR & CIRCULAR • C/KU LINEAR & CIRCULAR • KU 12 GHz FEEDS
- INTELSAT 4 GHz CIRCULAR • ARABSAT S BAND FEEDS
- OPTIONAL: CO-BORSIGHT S BAND

2216 AGATE COURT, UNIT B, SIMI VALLEY, CALIFORNIA 93065 • (805) 526-5249 • FAX (805) 584-0634

## NOKIA MEDIAMASTER 9500S/ SKANDIA SK888 REPORT

### Forbidden Fruit

A very small quantity of Nokia MediaMaster (9500 S) receivers found their way into the Pacific since our November issue; the first such units outside of Europe and North America. The initial reports, including our own check of the performance as tested by SatFACTS, are mostly negative. This unit appears to have great promise but unfortunately lacking suitable written instruction in a language most of us would understand (i.e., English), we cannot be certain of just how useful this receiver may ultimately be at this time.

There are multiple sources for Nokia in Europe, where the units are manufactured, and each has its own 'story' as to the status of the IRD unit. Bentley Walker Ltd. (1), for example, advises "*The Nokia DVB 9500 S is coming into the UK in the European language format at present but will soon be available in English.*" Like most first-available products, the Nokia through this and other UK sources are being quoted in the Sterling 400 region. Additional sources have popped up in Germany and Italy; at least two of the first units to arrive in New Zealand came through a German source and we cannot recommend this source to others for a variety of reasons (2).

The first unit into Australia/New Zealand as a commercial product apparently went to G & G Imports (Darwin) (3). Their non-English format unit was received late in October under an arrangement which G & G believes will lead to their being a stocking distributor for the unit. Firm owner Clayson Gibbons is the only early recipient of a 9500 S to report it works satisfactory although the detail of just what it does is unclear as we go to press (4).

Not as fortunate was Telsat Communications Ltd (5) which received a test unit early in November. The unit presented some set-up problems because of the C-band

barrier but ultimately did produce CNBC and NBC Asia at a test session under the guidance of Steve Jepson in Levin (NZ). Shortly after producing the NBC services from PAS-2 the receiver fried its power supply (that is not good) and further testing came to a stop.

Equally unfortunate was Bay Satellite Ltd (6) which received a pair of units through a German source in mid-November. The manual supplied is in German and Italian, as are the on-screen menu and prompts. Of the two, for those not fluent in either language, the Italian would prove to be more friendly.

All units received to date are factory programmed for Ku band use. There appears to be no assistance in the manual nor the menus to help you get into a C-band mode. Jepson sorted this out on his own without apparent penalty; Gibbons at G & G went to Nokia for assistance (subsequently Nokia sent a draft of an English language instruction set to Gibbons for review and correction). BaySat with two Italian/German units was unable to go further than turning the units on for Ku-band (using the Galaxy FTA service) and one of their units "locked up" and refused to accept any further commands.

None of this, at this stage, is dealer nor consumer friendly. In their defence, Nokia advises Gibbons, "*We did not originally intend to supply receivers to the Pacific/Asia until the middle of 1998. The factories are struggling to keep up with the present European demand.*" European demand is not the full problem; the 'basic' MediaMaster is capable of being utilised as a cable TV set-top converter box for digital delivery as well and Nokia through TV Com International has a significant commitment to supply units for this purpose as well (cable boxes are 8500 C).

The lack of English instruction aside, there remains the strong possibility that under the same product number (MediaMaster DVB 9500 S) there are multiple versions of this receiver. It may be that only the software differs from version to version, and it may further turn out that the primary differences in software are in language. Still, that does not explain why the two units received by BaySat were so totally unfriendly nor does it explain why BaySat's German source told them, after the units arrived in New Zealand and did not work, that "*You have been shipped the wrong units, those were intended only for Germany*" and then called the BaySat versions "D Models." (7) At the very least, there is plenty of misinformation about concerning just what the

1/ Bentley Walker Ltd, which specialises in hardware for Africa and Middle East tel +44-1705-463-943 fax +44-1705-461-465 (A. Walker).

2/ One reason for not recommending the German or Italian sources is language; when the on-screen and printed menus are in an unfamiliar language, and the staff of the firms speak limited English, the combination is deadly.

3/ G & G, Clayson Gibbons, at tel/fax +61-8-898-860.

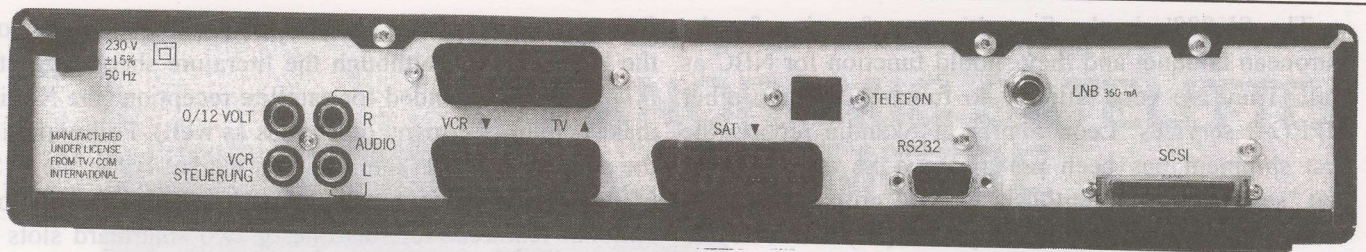

SCART only outputs on 9500 S although audio only outputs are on rear apron. "VCR" is for controlling external VCR; 0/12VOLT is switching voltage to select between two satellite antennas and requires "HF-Weiche" accessory switch box. SAT TV appears to be SCART connection to (external) analogue satellite receiver to allow user to loop all satellite reception through 9500 S. SCSI is external connection for CD ROM, CD Digital, Photo-CD devices. Tuner covers 950-2150 MHz, Msym rates of 2 to 45 and satellite bandwidths of 1.2 to 54 MHz.

MediaMaster is capable of doing in various reception situations.

BaySat after locking up one of their two units sent it to New Zealand's IRD aficionado Robin Colquhoun who was successful it getting it to play on Galaxy (FTA) service. Colquhoun, next equipped with the Gibbons instructions, attempted to get the unit to function on C-band. On one occasion it did recognise the presence of the NBC bouquet from PAS-2 but would not display actual reception (only the bottom of screen identification statement). That this Ku-friendly unit was actually functioning for a C-band input could not be determined.

Meanwhile a representative of Nokia, appearing at the Hong Kong Cable and Satellite show late in November, was doing little to clear up the muddle of information. They told one attendee, "A free to air version for the Pacific and C-band use will be available sometime in the first quarter of 1997, price range (distributor net in quantity) near \$650." Another attendee was shown an operational unit with "new menu software that appeared far easier to use than the early test samples" but "the new software will not be routinely available in units being produced until sometime in December."

The bottom line on the MediaMaster 9500 S? Avoid the early shipments especially if they are coming from Europe and do not include at the very least an English manual and English on screen software. Next, obtain the assurance of the seller the receiver is fully functional for C-band use and will not require a special LNB(F) for C-band (8). Pricing: Difficult to pin down what the real market price is or should be since the units being offered are going through several "steps" on their way to the Pacific. Garry Cratt of AV-COMM Pty Ltd who has followed the Nokia's progress closely suggests, "Their price is about twice that of most other makers." So these remain early days for the Nokia in the Pacific/Asia.

#### The Skandia SK-888

A small shipment (low hundreds) of units was shipped via air freight to Skandia Electronics (9) November 30th. The units cleared customs December 5 and one was to be sent air courier to SatFACTS that same day. This magazine page will go to our printer December 9 so you can see the problem involved in getting you a suitable report in this issue.

#### DVB 9500 S Set-Up According to Steve Jepson

Notes: Video output only available through SCART sockets (SCART to SCART lead was supplied).

There was no RF modulator in this receiver.

- 1) Switch on, screen menu with "welcome" in several languages
- 2) Select least foreign language to you and arbitrarily select a country as prompted (to set local time). (There are no Southern Hemisphere countries listed so this is done to follow the routine, not for any other purpose)
- 3) Main menu does not allow you to select C-band
- 4) SO - proceed to "TV" set-up menu and install FEC, Symbol rate, RF direct frequency (not IF)
- 5) Using remote, "force" the LO (local oscillator) frequency to 5150 MHz; then press "OK"
- 6) Now enter search mode and receiver should find any MPEG-2 FTA sources on your satellite of choice (how one enters 'both polarisation sides' of a single bird or multiple birds is not clear.)

#### DVB 9500 S Set-Up According to Clayson Gibbons

Notes: These instructions supplied by Nokia.

- 1) Switch on, enter Welcome menu.
- 2) Select a country (any country) for setting local time
- 3) Select a satellite: AsiaSat 2 is not listed; select any other
- 4) Receiver enters search menu, Press OK and receiver will do initial (unsuccessful) search
- 5) (After unsuccessful search) press Menu on remote control; select installation and press OK.
- 6) Select antenna adjustment and press OK
- 7) Enter parameters for AsiaSat 2:  
Transponder freq. 4000 MHz, Horizontal polarisation, 28.125 symbol rate, 3/4 FEC.
- 8) LNB Frequency Low band (menu text may not properly say this): enter 5150
- 9) LNB Frequency High Band: enter 0(0) MHz
- 10) Press OK to enter search menu
- 11) Press OK to start search

The SK888's in the first shipment function for the European bouquet and they should function for NBC as well. They are very unlikely to function for any other MPEG-2 services. Leon Senior at Skandia reports the first shipment has been pre-sold and he also believes that "serious satellite enthusiasts" will probably want to wait for the second or third shipment (10) which he has been told may receive additional FTA MPEG-2 formats in addition to EBB and NBC.

A prototype SK888 tested at Skandia showed limited capabilities to handle at least some of the AsiaSat 2 programme channels only previously available on the very expensive DMV/NTL 3000 receivers. Word of this "extra capability" had progressed through some segments of the industry. Leon Senior was quick to warn early buyers that at "this time" the SK888 will not provide access to these alternate programmers.

So where does that leave the dealer/installer of MPEG systems? If your customer is after the European bouquet, you now have several sources (Panasat IRD520, Pace DVR500, Skandia SK888, Nokia 9500 S), all of which will also do the NBC Asia bouquet. Other programming? Not yet.

#### Philips IRD INS 610

Another world-class entry into the DVB Compliant MPEG-2 world is the Philips receiver which has been selected by Malaysian satellite telecaster Measat. The

4/ We are unclear which services the receiver does access, certain only that it "does" the NBC bouquet and the European Bouquet.

5/ Telsat Communications, Ltd. tel 64-6-356-2749, fax 64-6-355-2141.

6/ Bay Satellite TV Ltd., tel 64-6-843-5296, fax 64-6-843-6429

7/ A subsequent advisory (30 November) from Nokia through Gibbons seems to verify the existence of multiple receivers all trading under the 9500 S labelling: "Your receiver will not function due to your D box settings not (being) programmed to receive signals in this region (of the world).

There is nothing that can be done to adjust your receiver" (emphasis added).

8/ One German source insists the receivers being shipped will function properly on C-band if you also purchase a "special LNBF" from the firm. No explanation what makes their LNBF "special" or why this might be a truthful statement.

9/ Skandia Electronics Pty. Ltd, tel 61-3-9819-2466, fax 61-3-9819-4281.

10/ Leon Senior believes 95% of the short term IRD market will be pure consumers (such as those anxious to have RAI International in their Australian homes) and 5% will be the serious enthusiasts. He suggests that those who fall into the "serious" class await SK888s which have greater MPEG capability. The second shipment is due into Melbourne just prior to Christmas.

INS 610 seems to have many of the design parameters of the Nokia 9500 S although the literature sheet suggests it is primarily intended for satellite reception (the Nokia makes claims for many other uses as well). Following in the pathway of other international market firms, the INS 610 appears to be available with a sizeable list of optional features (such as one or two smartcard slots - readers, data processing in addition to video and audio, internal telephone modem for pay TV ordering).

That different versions are available for specific bouquet packages, Philips notes, "*The IRD supports the advanced bitmapped subtitling system, Region-based Graphics (optional).*" And they introduce yet another acronym to our growing lexicon of MPEG short hand: RbG which stands for Regional based Graphics. They report, "*The RbG will display subtitles and graphics in any language or character type including oriental languages.*" When the user selects a language for operation (which is reflected in the menu instructions), "*Subtitles are selected automatically in the end-user's language.*"

Increasingly it becomes more and more obvious that our worst fears that MPEG really means a multitude of geographic area specific software routines is happening all around us. For patent and market control reasons the likelihood that the marketplace will see a "universal MPEG-2 DVB Compliant receiver" becomes less and less likely with each passing month. For the "serious satellite enthusiast" this is bad news; if you live where you will have access to two or more geographic-targeted MPEG-2 services, you will require separate receivers for each service (see SF#25, p. 6 and 12). All of this points up the need, as evidenced by the Nokia results to date, to be very certain that the brand-name IRD you are sourcing for your own needs will in fact function with the bouquet(s) you have access to in your region. At this point none of the manufacturers with the possible exception of Pace seem willing to differentiate their model numbers with identifying numbers or letters that help you identify which bouquet(s) a particular unit is designed to function within. An example of this: The Nokia 9500 S unit initially tested by Steve Jepson on behalf of Telsat Communications, Ltd. had a hand scrawled "C Board" notation on the container, indicating that at some point prior to shipment somebody had taken the effort to reprogram the receiver for C-band use. The two "D box" units imported by BaySat had no such indication of C band capability. And once inside the outside container, none of the literature nor instructions packed with the Jepson unit suggested a C-band capability either.

Finally this postscript. Telsat was able to obtain a prompt replacement for the power supply defective Nokia unit and Jepson reports it functions "very well" on EBB and the NBC bouquets. We obviously have much work to do in this evolving area of receiver compatibility and our analysis shall continue.



# PANORAMIC SATELLITE METRE

## MC10-SAT

AU\$1599 (TAX-EX)

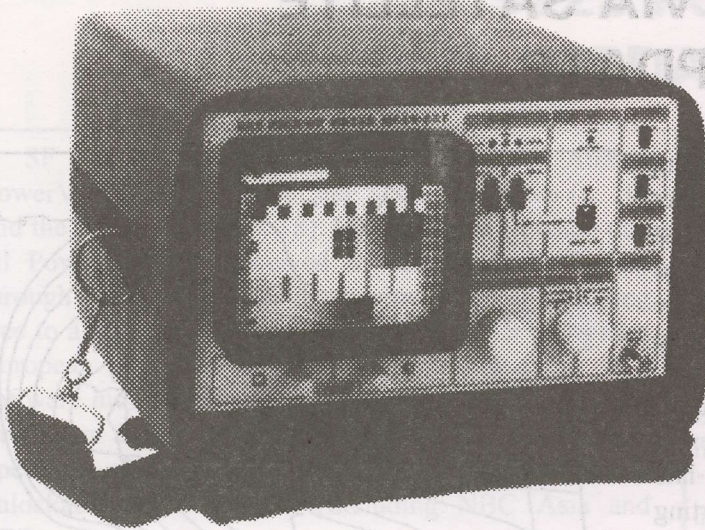

A PERIFELEC  
PRODUCT

- SATELLITE POINTER AND FIELD INDICATOR WITH RECEPTION ON 14cm (5.5") SCREEN
- FREQUENCIES FROM 950 TO 2150 MHz
- DISPLAY OF FULL-BAND AND EXPANDED SPECTRUMS ANALYSER
- DISPLAY OF PICTURE OF SELECTED CHANNEL
- POSITIVE (Ku Band) AND NEGATIVE (C Band) VIDEO DEMODULATION
- MEASUREMENT OF SIGNAL RECEPTION STRENGTH BY WHITE BAR SUPERIMPOSED ON THE PICTURE AND PROPORTIONAL IN LENGTH TO THE SIGNAL IN STRENGTH
- RANGE OF MEASUREMENT OF SIGNAL STRENGTH BY WHITE BAR SUPERIMPOSED ON THE PICTURE AND PROPORTIONAL IN LENGTH TO THE SIGNAL STRENGTH
- RANGE OF MEASUREMENT OF SIGNAL STRENGTH FROM 50 TO 90 dBµV
- POWER SUPPLY TO LNB IN 14 OR 18 VOLTS AND 22 KHz
- BATTERY LIFE : ABOUT 1 HOUR
- WEIGHT : 5.1Kg

THE MC10-SAT SATELLITE FIELD STRENGTH METER IS NOW CONSIDERED AS THE ESSENTIAL TOOL FOR ADJUSTING SATELLITE RECEPTION DISHES. THE VISUALISATION OF THE SPECTRUM AND THE PICTURE ALLOWS THE CARRYING OUT OF ALL THE NECESSARY ADJUSTMENTS WITH THIS ONE INSTRUMENT.

**FREQUENCY RANGE :** from 950 to 2150 MHz  
**TUNING:** Multiturn potentiometer  
**INPUT IMPEDANCE :** 75 Ohms  
**INPUT CONNECTOR :** F-TYPE  
**INPUT ATTENUATOR :** 0.10 & 20 dB USING 3 POSITION SWITCH

**SIGNAL STRENGTH :**

- **INDICATION :** by a white bar superimposed on the picture, its length being proportional to the strength of the received signal, and also by audio indicator
- **READING :** on the scale from 0 to 70 dBµV
- **MEASUREMENT RANGE :** from 50 to 90 dBµV

**LNB POWER SUPPLY :** 14 or 18 V and 22 KHz by switch

**DISPLAY ON 5.5" CATHODE TUBE**

- **SPECTRUM :**
- Full band spectrum (FROM 950 TO 2150 MHz)

- Expanded Spectrum with visualisation of the counter-polarisations

**- PICTURE :**

- positive video polarity (Ku Band) or negative video polarity (C Band)
- Picture of selected channel only
- Picture of selected channel with signal strength indication

**POWER SUPPLY :** 12V, 3 AH battery

**CONSUMPTION :** 1.2 A (without LNB)

**BATTERY LIFE :** about 1 hour

**CHARGING TIME :** about 4 hours

**DIMENSIONS :** 240 x 140 x 270mm

**WEIGHT :** 5.1Kg

**ACCESSORIES INCLUDED :** Measurement cord, AC mains adaptor, charging lead for car cigar-lighter, case.

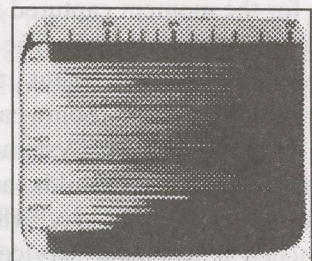

FULL BAND SPECTRUM

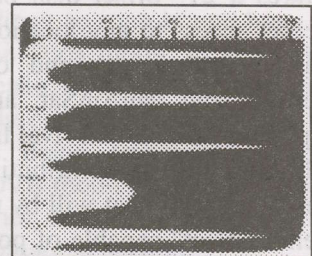

EXPANDED SPECTRUM

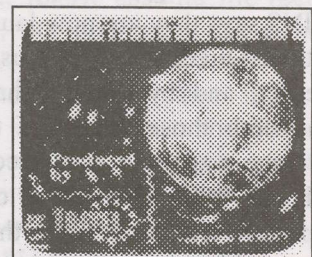

DEMODULATED PICTURE



PICTURE + MEASUREMENT



TEL 61-2-584 1233 FAX 61-2-584 1452

99-105 BOUNDARY ROAD, PEAKHURST NSW 2210 AUSTRALIA

## INTERNET VIA SATELLITE UPDATE

Delivery of medium high speed access to Internet data bases through satellite feeds remains just beyond direct reach as this issue of SatFACTS goes to press. The most promising system, seemingly the easiest to install and use, as reported in SF#27 (p. 14), through the Deutsche Welle feed on AsiaSat 2 is now unlikely to be in routine operation much before the February-March time frame.

An American based firm, Hughes Network Systems, has for the moment captured the imagination of Internet enthusiasts in the Pacific region with their late November announcement that DirecPC is starting operation for Japan. Some background.

Hughes Network Systems (HNS) is owned by the same Hughes that builds and operates satellites. As reported in SF#27 (p. 18), during October HNS launched a Ku band service in North America which features a 21" offset dish bringing 400 kbps one-way Internet access to any location with a PC. The Hughes division that owns and operates its own fleet of satellites, and PanAmSat, are merging into a single corporation which will rival Intelsat in scope and service ability. Hughes is contributing 13 operating satellites, PanAmSat 8 in what will by the middle of 1998 be a 21 satellite "fleet" capable of poking C, Ku and eventually Ka band coverage into virtually any spot on the globe.

HNS says they are now launching a "Japanese version of their DirecPC service" using PAS-2. The content is Internet, and by using a half transponder (27 MHz) bandwidth those inside of the 49 dBw contour (see coverage map) will gain access to Internet at speeds as high as 400 kbps. The competition here are the respective telephone firms that today provide 14.4/28.8 kbps modem connections to Internet. It also appears (the early information is sketchy) that data, radio and video packets as great as 3 megabits per second can also be moved through the system.

DirecPC in the USA (through the PanAmSat Napa, California uplink) will link through PAS-2 to the Ku-band Northeast Asia beam and trade under the name of Direct Internet inside of Japan. The early descriptions of the service do not mention there being a commercial service offering outside of Japan but as the coverage map shows, a region from Hong Kong along the China coast and Taiwan through Korea and Japan will all have the same effective footprint levels (i.e., a system that will work in Japan will work equally well anywhere within the same 49 dBw contour). The actual dish size

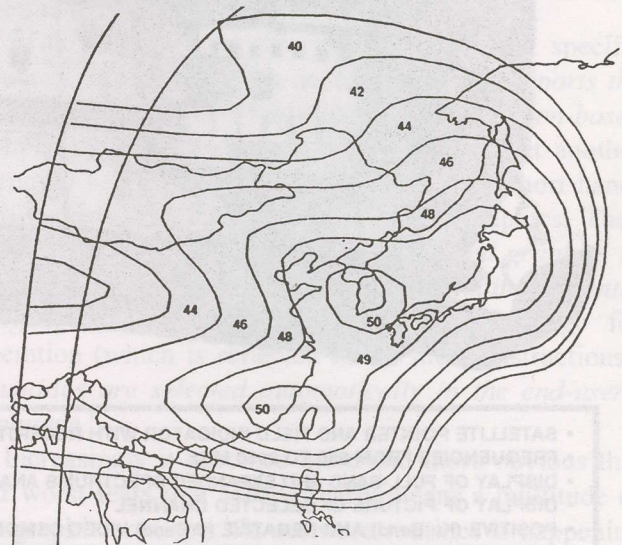

PAS-2 Northeast Asia beam covers all of Japan, coastal China, Taiwan, Korea and Hong Kong inside of 49 dBw contour.

required is not forecast but it appears a 60cm dish will function inside of the 49/50 dBw regions while outside dish sizes will increase in small increments.

Direct Internet has some powerful Japanese partners including Hitachi Cable Ltd., Japan Telecom Co. Ltd., Sony Music Entertainment (Japan) Inc., and Parallel Technology, Inc. The firm is establishing headquarters in Tokyo and will supply DirecPC products as well as installation and support services.

Beyond the Asian core market, HNS has admitted it is also looking closely at establishing a similar service for Australia. New Zealand is not mentioned, but if PAS-2 is chosen as the distribution satellite then New Zealand will be within the same Ku footprint as much of Australia.

### MEANWHILE - MediaNet Status

For most of us in the coming 90 days the major Internet event will be the start-up of routine MediaNet operations. As reported on p. 2, the service is operational in Europe and the Americas via several satellite links. Testing on the AsiaSat DW link is likely to begin before 1 January but is unlikely to be seen by more than a handful of early trialists until the first Internet sessions at SPRSCS '97 in Auckland January 23. Two versions of the decoder are to be available; an analogue unit which will work through the analogue format video output from the IRD, and a digital version that will work directly from the MPEG-2 feed.

# SA 9223 POWERVU UPDATE

SF last visited the status of the Scientific-Atlanta PowerVu MPEG format in our September issue (p. 20) and the August issue (p. 18). In August we reported that all PowerVu units received in Asia and the Pacific through early August had proven incapable of accessing free to air MPEG-2 service such as the DVB Compliant European bouquet. In September we reported on a software modification, provided by S-A Sydney to New Zealander Robin Colquhoun which did, with some operator skills, access many of the previously unlockable FTA services (including NBC Asia and EBB).

The 'test software' supplied to Colquhoun appears to now be the 'standard software' in all D9223 units being shipped through the Sydney office. This means it is possible if you have the necessary skills to utilise menus buried inside of the D9223 to access not only the various PowerVu feeds (now China on 1433.5 Vt, Discovery Singapore on 1373 Hz, California on 1249 Hz, Hong Kong on 1002 Vt, TCS Singapore on 967 Hz) but also at least some of the non-PowerVu format feeds. This warning: There are now two versions of the D9223 software out there - the original software which does nothing but PowerVu, and, the updated software which does more (with operator skills). And - some of the original version receivers are still be peddled by a Hong Kong firm at pricing which is slightly better than the normal Sydney office pricing.

Further update. Sydney is now offering buyers the opportunity to have either the (new software version) D9223, or, a less expensive "economy" model which they call the D9234, described as a "business user model." The '34' adds an RF modulator (for direct view on a normal TV set) and a hand held remote control for programming but has done away with the front panel LCD display. Sydney S-A is quoting the 9223 at A\$1,575 plus shipping (tax where applicable) and the 9234 at A\$1,250. S-A on December 5th advised the 9234 was going to be in limited supply until the next product (manufacturing) run scheduled for March; allegedly there are "only 500 of these units for the entire planet until the next run." Unknown is whether the 9234 units will have the undesirable "first level 9223 software" or the "FTA MPEG compatible software" now inside the current 9223s being supplied. The data to the right first appeared in Coop's Technology Digest for August 23rd. The source was associated with an uplinker using PowerVu equipment. Disclaimer: Those who try this are on their own!

## MPEG-2 Mode vs. DVB Mode in 9223

You won't find this defined in the PowerVu 9223 manual - it could be the most important reason why someone who is NOT a cable system or other receiver-dedicated-to-a-single-service user might wish to own a D9223.

There are three operating modes possible with the current 9223 receiver series. Apparently receivers nominally come out of the box in what S-A calls "The DVB Mode." In this mode the receiver accepts instructions from the PowerVu uplink to retain its operating parameters. The receiver is also capable of an "MPEG Mode" and a "PID Mode."

The average non-dedicated-receiver user appears to have maximum flexibility in tuning in the various FTA level PowerVu services when the receiver is in the "MPEG Mode." CCTV on PAS-2 (IF 1433.5, Vt) for example can be difficult to tune in and have lock if the receiver is in the DVB mode. In the "MPEG Mode" it is a piece of cake, even with a small dish.

MPEG Mode basically cuts the receiver free from the control functions being transmitted by the PowerVu uplink. The DVB mode makes the receiver a slave to the uplink; not desirable if you like to go PowerVu "programme channel surfing."

The instructions that follow assume the receiver is out of the box (i.e., not previously set different than the) DVB Mode. Your goal: To get to the MPEG Mode. The instructions relate to which D9223 keypad button is pushed and the sequence for pushing the buttons. The numbers appearing before the instruction are only for sequencing - they do not translate to actual buttons to push!

- #1) Menu
- #2) User
- #3) Next
- #4) Yes
- #5) "6" (on keypad)

At this point stop and read the on screen menu. Towards the bottom there will be a three line listing that lists three choices (DVB, MPEG, PID). If the receiver is in DVB (most likely) it will tell you this. If it is in MPEG already - STOP at this point and go to step 7. If it is in DVB, restart with step #6.

- #6) User
- #7) Yes
- #8) View

Once in the MPEG Mode there is probably no reason to ever return to the DVB mode as the receiver will "better" in the MPEG Mode.

## SOUTH PACIFIC REGION SATELLITE & CABLE SHOW '97

The assumption is that you are somehow involved in the sale and installation of home (DTH) systems, in SMATV or cable TV, or, you are a "serious enthusiast" who lives and breathes the world of satellite delivered information. The South Pacific Region Satellite and Cable Show (SPRSCS) for 1997 is the third (annual) event and the second to be held at the University of Auckland Tamaki Campus. The facility is near ideal for our needs as an industry as we are between school sessions (i.e., the campus is virtually deserted), a several acre hard surface lot is located directly in front of the trio of lecture theatres (and makes an excellent location for viewing satellites across the full arc), plus the University has done an excellent job of designing well equipped lecture halls which seat up to 230 people in

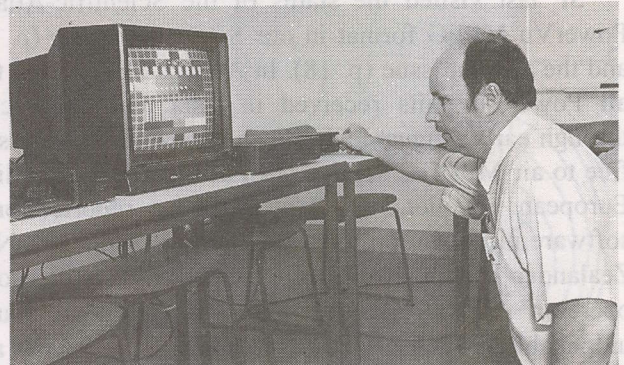

Barry Ward (Auckland) has built a satellite spectrum analyser using commonly available (Dick Smith) parts and a 'junker' oscilloscope. He will explain how he did this and give assistance to others in duplicating his "low cost analyser" (as little as \$300) during SPRSCS '97.

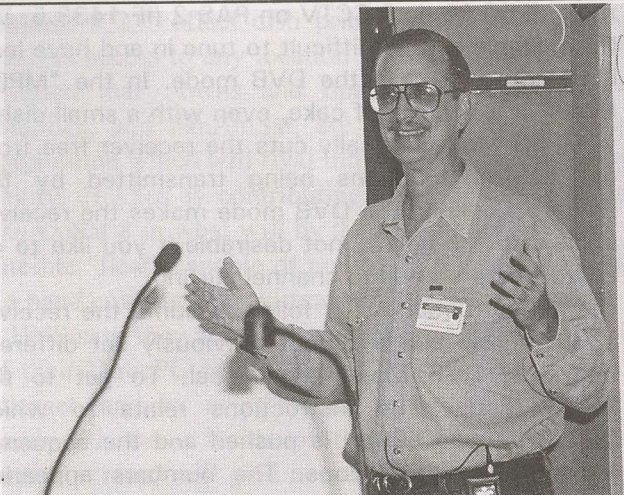

THE DOCTOR IS IN - Mark E. Long, author of The World of Satellite TV and founding publisher of The World Satellite Almanac headlines extensive training courses throughout SPRSCS '97

numerous new entrants in the MPEG-2 DVB Compliant receiver world. A special session entitled "*What Scientific Atlanta Forgot to Tell You About the 9223 Receiver*" will be good to its title. The hot new technology for 1997 will be the distribution of Internet via satellite. As detailed in recent issues of SF, there are two separate projects in this area - the Deutsche Welle MediaNet service and the DirecPC (Internet Direct) package. Both will be described in as much detail as is available and MediaNet will have its first Pacific public display in sessions on Thursday January 23. And because of the explosive interest in this new level of DTH (direct to home) technology, SPACE Pacific is teaming with PC (NZ) Magazine on Saturday January 25th to put on a special one day (4 hour) symposium

comfortable theatre-style seats.

SPACE Pacific returns to the 1996 show site challenged to make the 1997 show as useful and important to attend as last year. The 1996 show was the first in the world to introduce the concept of the European Bouquet, the first to prove the coverage capabilities of the then-new AsiaSat 2 satellite, and the first to provide a forum for the introduction of the NBC digital bouquet in either the Pacific or Asia.

SPRSCS '97 will concentrate on one maturing and one brand new technical area of concern. Several sessions are scheduled to cover as thoroughly as possible the



Zoning restraints on satellite dish installations? SPACE forums will blend experience with suggestions such as this "temporary mount" that requires no permits.

# Signal Level Meter Special

**LIMITED  
STOCKS  
FOR  
ONLY  
\$799.** AUD  
PLUS  
TAX

stockist discount available

A precision calibrated satellite signal level meter featured for digital and analogue! SWEEP allows easy location of all active transponders, whilst the TONE function provides an acoustic indication of signal level. Then tuning to the 1st IF frequency of the service sought, LNB position is simply optimized for peak signal level, and switching the LNB to the opposite polarity ensures optimal rejection of adjacent channels. Equipped to power the LNB (and operate 14/18V polarisers) from a substantial internal rechargeable battery, the TC 60 facilitates precision installation of dish and LNB without a receiver in sight! The TC 60 will even measure the current an LNB draws helping identify an LNB likely to fail in advance. Carrier to noise measurements are easily made as the TC60 is calibrated in both dB $\mu$ V & dBm. Improve your productivity with instrumentation from Sadelta.

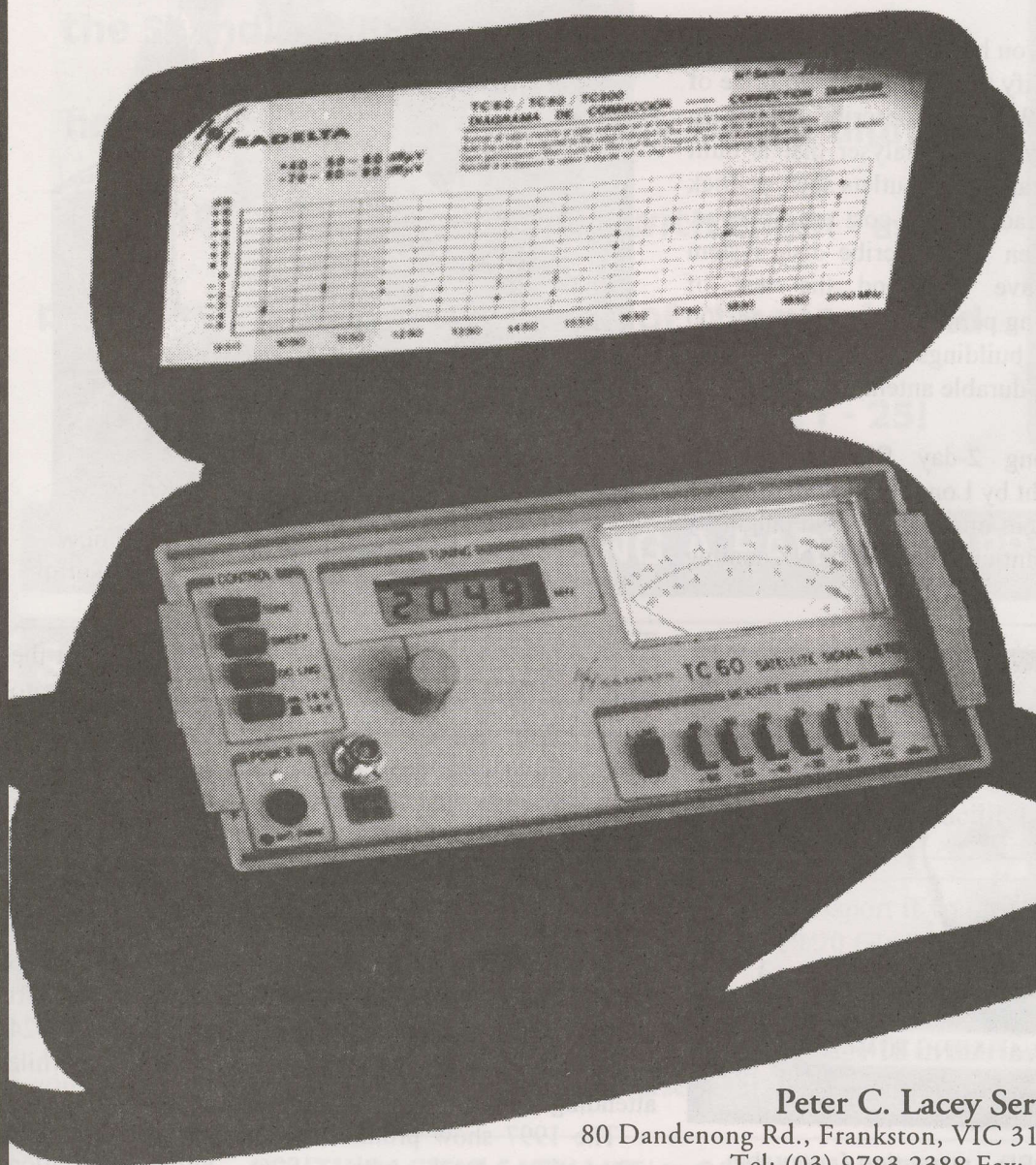

#### SPECIFICATIONS:

Frequency Range:

940-2060MHz.

Freq. Accuracy:  $\pm 1\%$

$\pm 1$  digit. Frequency

Resolution: 1MHz.

Dynamic Range:

12dB. Sensitivity: 40

to 100dB $\mu$ V (-70 to -

10dBm). Scale:

dB $\mu$ V / dBm. IF

resolution band-

width: 15MHz.

Power: 12V 2.6Ah.

gell cell, rech. Im-

pedance: 75 $\Omega$ . Input

Connector: BNC.

Size: 220 x 105 x

235mm.

Weight: 3.4Kg.

Frequency Sweep:

simplifies locating

satellite. Tone: in

proportion to level.

LNB Power: 0/14/

18V short circ.

protected. I LNC:

measures LNB

current to 300mA.

**Peter C. Lacey Services Pty. Ltd.**

80 Dandenong Rd., Frankston, VIC 3199 AUSTRALIA

Tel: (03) 9783 2388 Fax: +61 3 9783 5767

e-mail: placey@netlink.com.au

branches in: Sydney NSW, Ulverstone TAS, & Woolgoolgs NSW

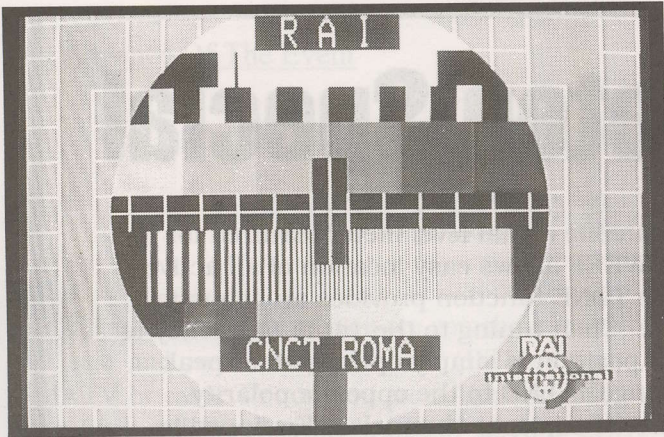

PROGRAMMING ISSUES - such as the furore created in Australia over RAI International

which is designed to bring to "the show" for that one day budding new users of DTH systems who have very little (or no) interest in television but an intensive interest in being connected to Internet at speeds in the 400 kbps region.

On the practical side, if you have lusted for a spectrum analyser but could not justify the relatively high price of a commercial unit, Barry Ward will describe a self-help project involving a do-it-yourself analyser that is built around parts commonly available at outlets such as Dick Smith and virtually any grade of low-cost oscilloscope. Equally practical, Eric Fien will describe dish system antenna mounts that have withstood the test of engineering review, building permit inspections and 200 kph winds atop high rise buildings - a "safe and sane approach to cost effective, durable antenna mounts."

Special events include:

1) The Mark Long 2-day SPACE Installer Certification Course, taught by Long January 21-22;

2) A Ku-band dish system mini-course also taught by Long on January 25th (in anticipation of Sky NZ coming to satellite in 1997);



SPREADING THE WORD - attracting favourable publicity for satellite services

3) The previously mentioned "Internet Symposium" also on January 25th (for which there will be an extra \$25 charge if you have signed-up for the January 23-24 primary conference).

For active SPACE members there are special sessions January 22, 24 and 25 (see tentative schedule p. 18, here). For those staying at the Barrycourt Motor Inn host facility, in-room (SMATV system delivered) industry training tapes dealing with the latest satellite and cable techniques (8-11pm January 23, 24). And new this year, for everyone, in a special cash-bar room at the Barrycourt- evening informal sessions from 8pm until - January 23 and 24. Included in the evening event January 24th will be the first ever "SPACE Pacific Awards" recognising members who have made significant contributions to the state of the industry during 1996, a tradition we feel certain will continue in

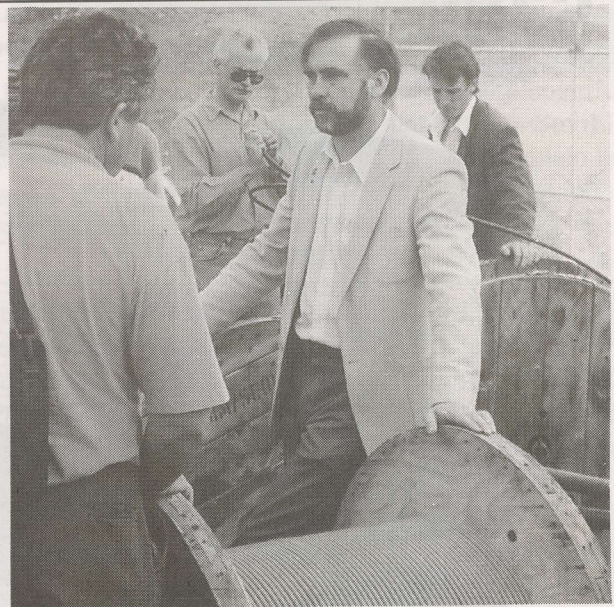

BASICS OF CABLE - from people who are now building cable TV systems such as Ron Theaker of Taupo Cablevision (here)

future years as well. The staging of extra events at the Barrycourt will also allow some of our trade firms to produce some extras of their own within the framework of the evening sessions.

If you have not yet made your reservations at the Barrycourt, and/or have not yet preregistered for SPRSCS '97 we encourage you to do both - today! If you are too late for the Barrycourt, ask them to assist you in locating alternate nearby quarters or tell your travel agent you want to be in the Parnell/Auckland region. As SPACE did in 1996, bus transport from the Barrycourt to the Tamaki Campus will be provided January 23-24 and 25 thereby reducing you need for a rental car while attending.

The 1997 show promises to be on a technical and information level with 1996. Full registration information appears on p. 15 in this issue.

# LET THE SHOW BEGIN!

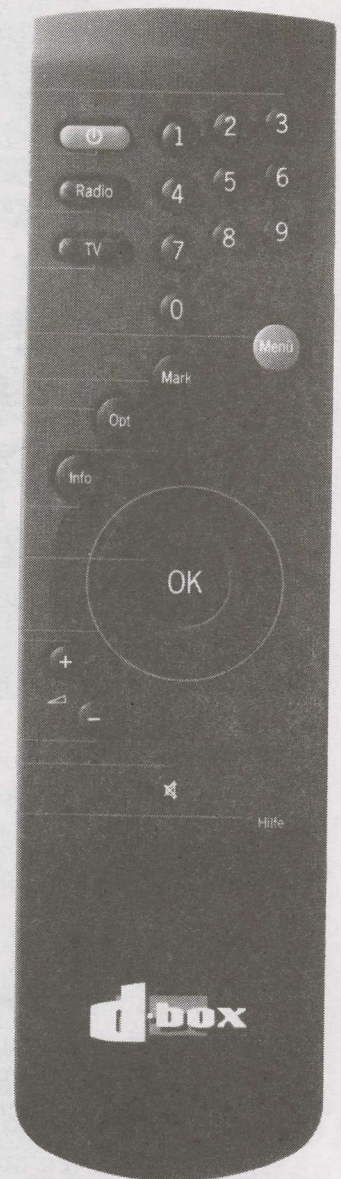

They will ALL be there - the NOKIAs, the PACE DVR500s, the Panasat IRD 520s, the PowerVu 9223s and even the Skandia SK888s. Each will be strutting on stage hoping to capture your fancy as THE digital TV IRD for 1997. Touch them - play with them - ask them to perform for you. It is all part of the magic and excitement of SPRSCS '97 in Auckland January 21 - 25!

## FOUR STEPS TO BEING A PART OF SPRSCS '97

### STEP 1

Contact SPACE Pacific today (tel 64-9-406-0651, fax 64-9-406-1083). If you have a VISA or Mastercard it can all be handled over the telephone!

Contact Barry Court Motor Inn for room reservations (tel 64-9-303-3789, fax 64-9-377-3309) - if full, ask them to help you find another nearby facility!

### STEP 2

### STEP 3

Arrange your transport and remember your passport if you are coming from outside of New Zealand! (Barrycourt address: 10/20 Gladstone, Parnell - Auckland)

Be on time! (See planned schedule as it appears in December, page 18 in this issue.) If you are not attending the Mark Long Installer Course - you should show up January 22.

### STEP 4

**SOUTH PACIFIC SATELLITE & CABLE SHOW January 21-25**  
at University of Auckland Tamaki Campus



## UNCLE BAYSAT ASKS ...

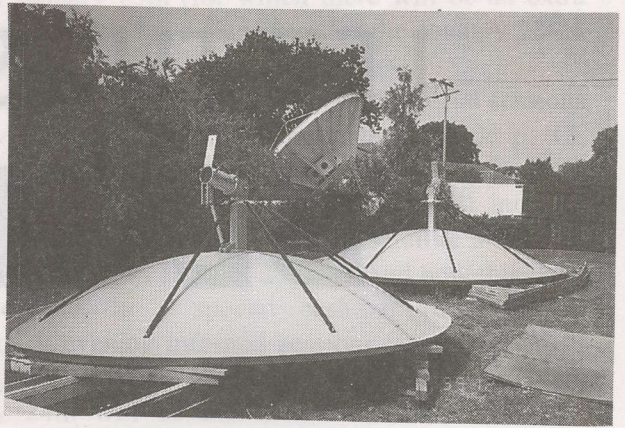

**Are your feeds getting too much ground noise, or, too little signal?**

NOBODY would purposefully point their satellite dishes directly into the ground expecting to receive satellite signals! YET - that is what you do if you select the wrong feed for your particular dish. No decision you make concerning packaging a DTH system is more important than the choice of the correct feed for the dish!

A FEED that OVER illuminates your dish might as well be pointing at the ground picking up terrestrial noise! Signal levels may measure good but your signals are buried in noise; not good!

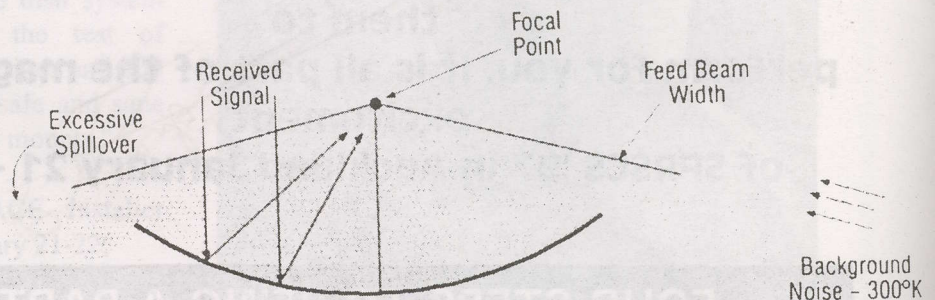

OR, a feed that UNDER illuminates the dish only receives from a portion of the surface, throwing away dBs!

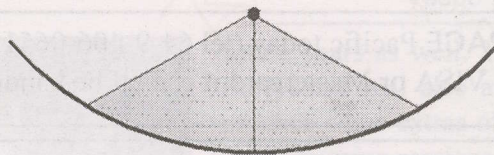

Don't leave dBs behind at the dish - get all of the signal your system is capable of producing!

Uncle Baysat recommends and uses for our own installations the versatile ADL range of feeds - there is ONE correct feed for every dish installation - ADL makes it and Uncle Baysat has it in stock!

**AND -**

If you are looking for the INSIDE TRACK to selling DTH INTERNET to users plan to attend our special "How to make money in satellite" seminars at SPRSCS '97!

**YES!**

We STILL accept  
VISA, Mastercard with  
no surcharge!

## BAY SATELLITE TV LTD

PO BOX 3311 • Napier • New Zealand • Tel toll free 0800-BAYSAT  
International 64-6-843-5296 • Fax 64-6-843-6429 (0800-229-728)

Physical location • 19B Carnegie Road, Onekawa, Napier

<http://www.baysat.co.nz/baysat>

e-mail [john@baysat.co.nz](mailto:john@baysat.co.nz)



## SL-8000RP

4500 years ago, the Egyptians were so far advanced in building technology that the pyramids were considered to be one of the Seven Wonders of the World. Today, still standing, these magnificent shrines to the achievements of man leave us marvelling at the skill and dedication of these ancient people. Fine craftsmanship is truly an ageless art.

Palcom receivers reflect skills and craftsmanship based on the same traditional values. The flagship of the Palcom range, the SL-8000RP is another marvel of technology.

## From BC2500 to SL-8000RP

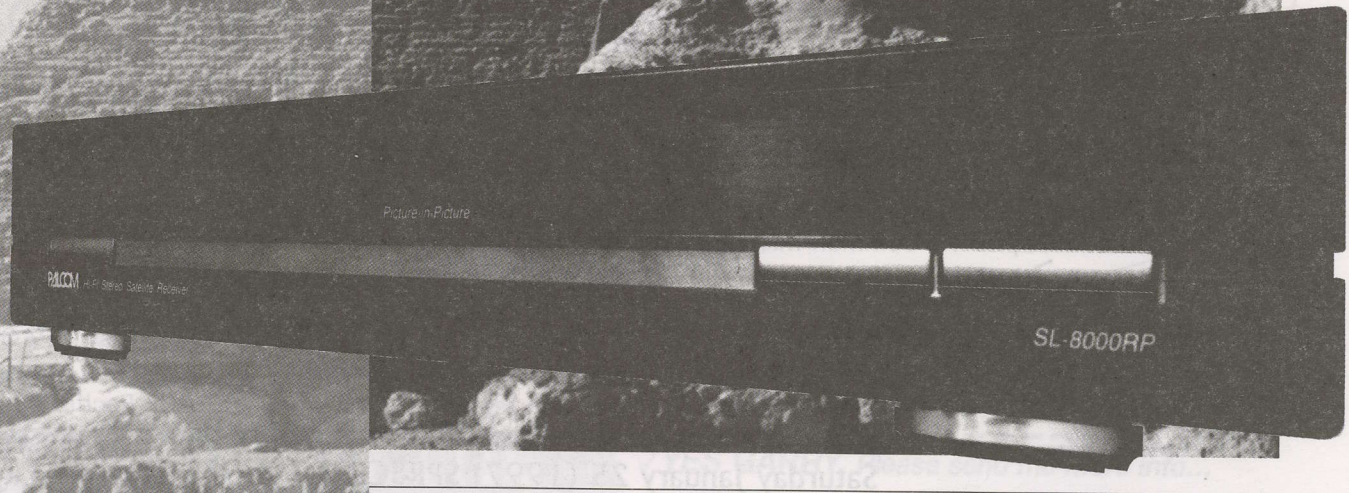

Its unique moving Picture-in-Picture feature permits the viewing of two channels at the same time (on one TV or two) or watching one channel whilst recording another. Mix images from satellite and terrestrial TV, satellite TV with VCR playback or satellite TV and security camera output with a choice of picture size for each image source.

The weakest signals may be viewed using the Palcom low threshold tuning facility producing improved video and audio performance.

A built-in antenna positioner provides access to all current satellites

500 Channels • 2 Timers • 3 IF Inputs • Weak signal Video and Audio processing • HiFi 1600 • Stereo Audio processing (surround) • On Screen Display in 6 languages • Channel Naming • Satellite Naming • LNB Naming • Decoder Naming • 16 Local Oscillator presets (adjustable) • 22kHz Tone Switching • Global and Fine Ferro/Skew adjustment • Alphanumeric Channel List • Favourite Channel Function • 16 Preset External Decoder configurations • Internal VideoCrypt ready • Timer / Priority switching for TV and VCR

with software by....

# PALCOM

State of the Art Simplicity

**Tuesday January 21 and Wednesday January 22 (1997) at SPRSCS '97**

- ▶ MARK LONG (MLE [Thailand] Co. Ltd.) conducts SPACE Installer Certification Course (advance registration required before January 10) over two days. This is the respected SPACE course offered by correspondence, taught by Mark Long in person in two days over 13 hours of intensive seminar sessions.
  - ▶ Dish antenna set-up days, antenna yard open for observers
  - ▶ Exhibit area set-up for exhibitor personnel (January 22: 10AM until finished)
  - ▶ Registration desk open for attendee packet pickup (January 22: 2pm to 5pm)
- ▶ SPACE Members Only: Programme access report and discussion (January 22: 2pm to 4pm)
- ▶ Videotape presentations: Society of Cable Television Engineers (January 22: 1pm to 5pm)

**Thursday January 23 (1997) at SPRSCS '97**

- ▶ 10am: Facts and Foibles of the DVB Compliant Receivers (covering DVM, Nokia, Pace, Panasat, S-A, Skandia models - what works and does not work and why!)
  - ▶ 11.30am: Practical Tips for DVB Receiver System Installs (Things not to do with the installation if you want reliable results!)
    - ▶ 12.15 - 1.30pm: **Exhibit areas open**
- ▶ 1.45pm: The Basis for Internet Delivery via Satellite featuring Johannes Firsbach of Deutsche Welle with support from Horst Wieser and others.
- ▶ 3pm: The Expanding Pacific Ocean Region Satellite World - detailed analysis of the satellites we have and those on the horizon in 1997/1998 (Mark Long)
- ▶ 4pm: Ethnicity - Identifying and Selling satellite systems to those with cultural and technical interests that differ from the mainstreams (Jim Hodgetts, TV5 Paris and others), *ENTON*
  - ▶ 4.30-7pm: **Exhibit areas open**
- ☒ 8pm - 11pm: At Barrycourt through the SMATV system on the EM TV channel - Satellite Interface featuring videotape instruction of satellite system installs and technology
  - ◆ 8pm til: SPRSCS '97 Cash Bar at Barrycourt Motor Inn

**Friday January 24 (1997) at SPRSCS '97**

- ▶ 9am: SPACE Members Only: Land-use zoning, building permit overview
- ▶ 10am: The Real World of Cable TV Entrepreneurship (four presenters)
- ▶ 11.15am: ~~Data and Other Exotic Packets Via Satellite~~ (Charles Margiotta, San Diego, Ca.)
  - ▶ 12 - 1.30pm: **Exhibit areas open**
  - ◆ 12.15 - 1.30pm: Lunchtime With Barry Ward as he describes his design and construction of a practical, do-it-yourself spectrum analyser
- ▶ 1.30pm: Practical Ways to Segment SMATV/Cable Spectrums (Daniel Bostick, Communications & Energy Corp., Syracuse, NY)
  - ▶ 2.30pm: Safe and Sane Satellite Dish Mounts (Eric Fien, Satellite Systems Installers Australia)
  - ▶ 3.30pm: 13 Common Mistakes When Adding Satellite Channels to MATV Systems
  - ▶ 4.15pm: What Scientific Atlanta Forgot To Tell You About The 9223 - *Robert*
    - ▶ 4.30-7pm: **Exhibit areas open**
- ☒ 8pm - 11pm: At Barrycourt through the SMATV system on the EM TV channel - "Dr. Dish" TV Show as telecast monthly throughout Europe on Astra
- ◆ 8pm til: SPRSCS '97 Cash Bar at Barrycourt Motor Inn featuring "First Annual SPACE Pacific Awards"

**Saturday January 25 (1997) SPRSCS '97**

- ▶ 9am-4pm: **Exhibit areas open**
- ▶ 9am: SPACE MEMBERS Only: Planning the 1997 Legislative Campaign
- ▶ 10am-12, 2-4pm: Ku-SKY-Direct Installer Course (Mark Long, Jim Roberts) (note: no extra fee for SPRSCS '97 Thursday-Friday attendees)
- ▶ 11am-3pm: INTERNET via Satellite Symposium cosponsored by PC (NZ) Magazine and SPACE Pacific featuring Johannes Firsbach (DW), Charles Magiotta, Horst Wieser and Jim Roberts (note: extra charge [\$25] to attend)

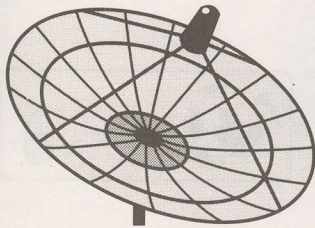

# AV-COMM SATELLITE TV EQUIPMENT

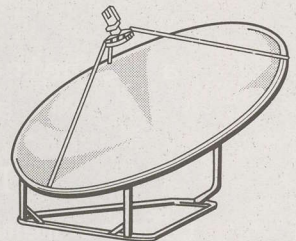

## INTRODUCING THE DYNASAT 300P RECEIVER

\*Plus Australian sales tax if applicable

ONLY  
**\$775\***

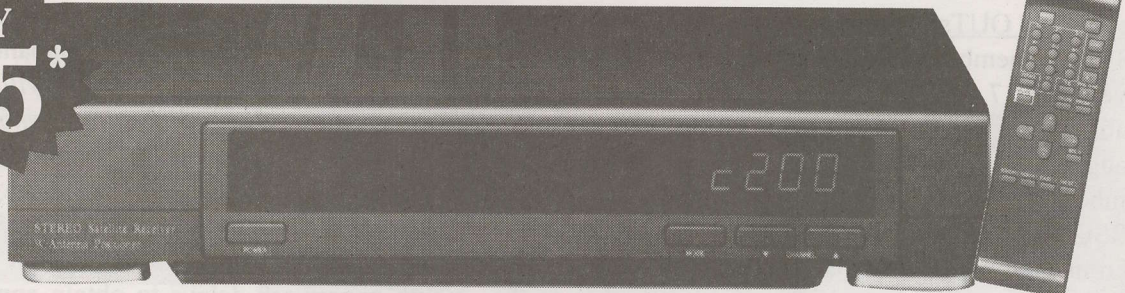

CAT #R1152

## LOW THRESHOLD RECEIVER WITH DUAL AXIS POSITIONER

### FEATURES

- 200 CHANNELS •••➔ PRE-PROGRAMMED WITH 90 CHANNELS VIEWABLE FROM AUSTRALIA & 40 FROM NEW ZEALAND.
- DUAL AXIS POSITIONER •••••➔ FOR INCLINED ORBIT SATELLITES
- DUAL INPUTS •••••➔ ALLOWS DUAL DISH/BAND OPERATION
- SCART & RCA OUTPUTS •••➔ MAXIMUM INTERCONNECTION FLEXIBILITY
- DUAL BANDWIDTHS ••➔ SUITABLE FOR HALF TRANSPONDER OPERATION
- FREQUENCY SCAN •••••➔ SEARCH FOR UNKNOWN FREQUENCIES
- 14/18V SWITCHING •••➔ USE DUAL POLARITY OR WIDEBAND LNB
- 20 STEP THRESHOLD EXT •••••➔ PRESET THE EXACT THRESHOLD FOR EACH CHANNEL

*\*We reserve the right to improve product performance without notice.*

### BENEFITS

## AV-COMM PTY. LTD.

DIRECT IMPORTER ACN 002 174 478

PO BOX 225, BALGOWLAH 2093

TEL: 61 2 9949 7417 9948 2667

FAX: 61 2 9949 7095

VISIT OUR WEB SITE AT

<http://www.avcomm.com.au>

✓YES GARRY, Please send me more info...

Name: \_\_\_\_\_

Address: \_\_\_\_\_

\_\_\_\_\_ P'code: \_\_\_\_\_

Phone: \_\_\_\_\_

a technical and marketing  
advisory

## memo

to the membership from your  
industry trade association

### SPACE Pacific

Satellite  
Programme  
Access  
CommittEe



A trade association for users, designers,  
installers, sellers of private satellite-direct  
systems in the Pacific Ocean & Asia Regions

#### The INs and OUTs of Antenna Restrictions

SPACE members met November 16 in Christchurch, November 17 in Taupo to discuss an agenda of troublesome topics now belabouring the industry throughout the Pacific. This is in preparation for member-only seminar sessions to be conducted during SPRSCS '97 in January (see tentative schedule, p. 18).

From these meetings it is now apparent that regional and city councils have taken diverse approaches to the regulation of "satellite" or "dish" or "microwave" antennas. We reported in SF #22 (June 15, 1996) that a Japanese family living in Christchurch had been taken to court for installing a satellite dish without a permit - lost in court and was forced to remove the dish. At least one SPACE member had cited this court case as "*the death knell for (C-band) home satellite TV*" in New Zealand. In actual fact, it turns out the installing dealer had not taken any steps to gain advance approval for the dish installation and while he may not have been legally liable under the law for placing the dish in the Christchurch residential area at the request of a client, he was at least morally obligated to have advised the client that permits were required before the installation could proceed.

We saw at the Christchurch meeting numerous photos of C-band dishes installed in the same city and the paperwork granted by the city to allow the installs; some as recent as early November. No dealer attending the Christchurch meeting could identify a single situation where, if the rules were followed in their city, a solution could not be found to place a dish in any location they

had attempted to date. This of course flies in the face of the earlier situation involving the Japanese family.

*"An installer/dealer who is not willing to follow the rules governing dish installations, who sells dishes and then disappears when his client is called on the carpet by city officials, has no business being a dealer at all"* was the consensus of those attending both meetings.

Yes - there are horror stories, some involving 3 to 6 month paperwork delays to obtain approval. And yes - there will be some locations where no matter how hard you try it will not be possible to gain approval for a dish install. Here is how it now seems to work.

First there is the Resource Management Act (RMA), a law adopted and put into effect in 1991. Under this act individual district councils in New Zealand have the legal right to create regulations governing any activity that the citizens of a community might object to. RMA covers everything from fluid disposal to building designs, removal of native trees to the placement of satellite antennas.

Second is a building permit; permission to construct a structure (including in some specified cases a satellite antenna).

Before you can file in most jurisdictions for a building permit, you must have RMA approval. In Christchurch, for example, a property occupant (owner) can take a consent form available from the city to every adjoining land owner. If each land owner signs the consent (which states they have no objection to the installation of a satellite antenna), then 90% of the RMA requirements are met. Once the RMA application, supported by the

## MEMBERSHIP IN SPACE

Membership in SPACE Pacific is open to any individual or firm involved in the "satellite-direct" world in the Pacific and Asia regions. There are four levels of membership covering "Individuals," the "Installer/Dealer," the "Cable/SMATV Operator," and the "Importer/Distributor/Programmer."

All levels receive periodic programme and equipment access updates from SPACE, significant discounts on goods and services from many member firms, and major discounts while attending the annual SPRCS (industry trade show) each January in Auckland. Members also participate in policy creation forums, have correspondence training courses available. To find out more, contact (fax) 64-9-406-1083 or use information request card, page 34, this issue of SatFACTS. Page space within SatFACTS is donated each month to the trade association without cost by the publisher.

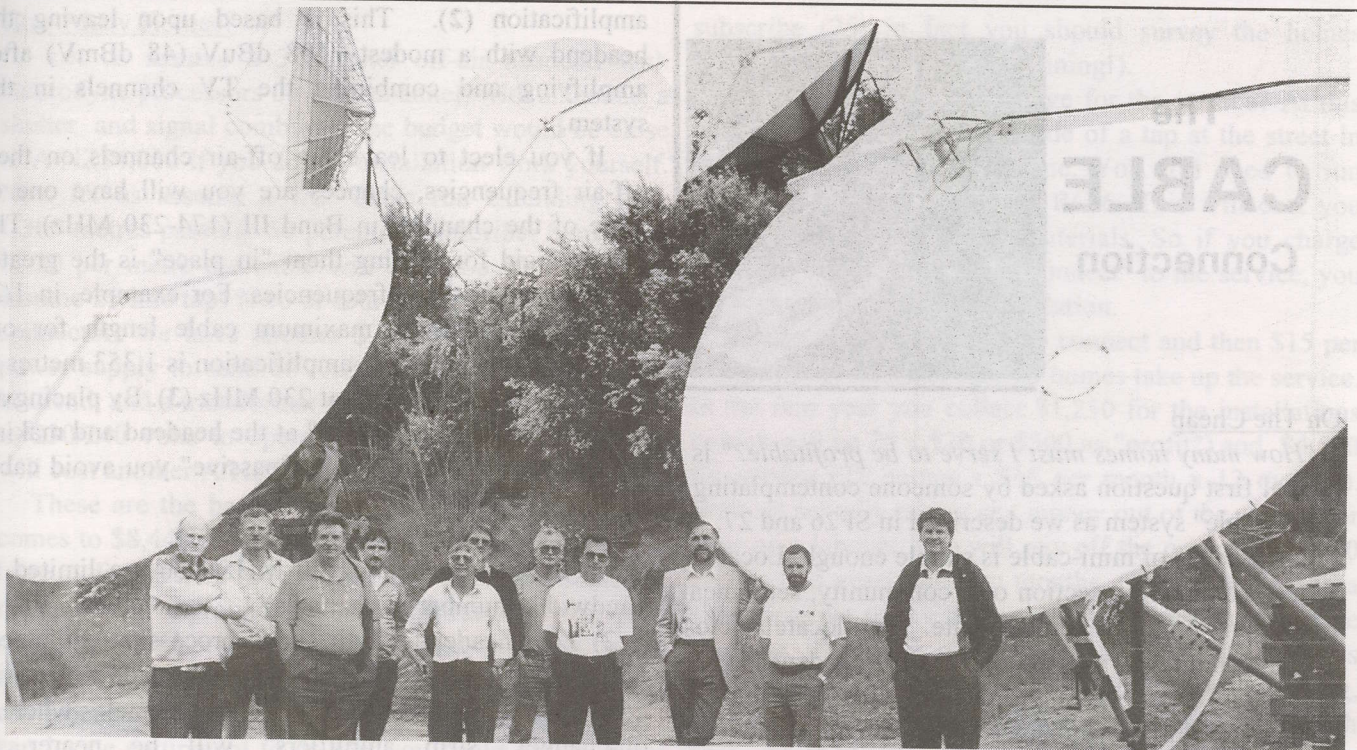

A portion of the 'North Island' group gathering at facility of member Taupo Cablevision - a sea of dishes providing multi-channel cable TV to residents of one of the country's top tourism attraction communities.

signed consent agreements are submitted to the council, there is every likelihood RMA approval will follow. However, there may be some conditions attached by RMA - one Christchurch application we reviewed (with 5 attached consent agreements) was approved provided the satellite dish owner would agree to planting new shrubbery that RMA decided was necessary to "keep the dish from being seen" by people in the street passing the home. The applicant in this case was more than agreeable to comply.

With the RMA approval in hand, next you take the building permit application to the appropriate council office. Here is where the technical aspects of the installation are important: What engineering standards apply to the antenna, how will the mount be designed and installed - for example.

The pathway to twin approvals may be tedious and slow in the first case - members tell us it gets far easier each time because of a growing familiarity with dish installations by council bureaucrats. There is immense value in sharing of successful techniques between members - a project SPACE is now actively working on and which will be previewed during special sessions conducted during SPRSCS '97.

There is a light at the end of this tunnel but there is no room for cowboy mentality as the Christchurch Japanese family learned. Details in the SPACE Membership Newsletter.

## FILTERS FOR CABLE TV YEAR #30\*\*

Our catalog has a filter for every CATV problem.

Ask for it!

We can also make your special filter in a hurry.

Just tell us your problem. We'll answer within 24 hours!



Emily Bostick  
President

*Emily Bostick*

**\*\* Emily & Glyn Bostick -  
Continuing a generation of personal service  
to TV INDUSTRIES WORLDWIDE!**



VHF BANDPASS FILTERS UHF



SATELLITE INTERFERENCE FILTERS

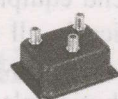

CATV DIPLEXERS



PAY-TV TRAPS

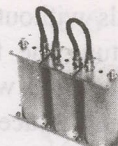

BROADCAST INTERFERENCE FILTERS

**BOSTICK FILTER DIVISION**

7395 Taft Park Drive  
East Syracuse, NY 13057  
Mailing address:  
PO Box 3307  
Syracuse, NY 13220  
Tel: (315) 452-0709  
Fax: (315) 452-0732  
Canada & US: 800-882-1587



COMMUNICATIONS & ENERGY CORP

### Contact Our Distributors:

MASER: Australia: Telephone: - 2 415 2877  
Telequipment Pacific Ltd.: New Zealand: Telephone: - 64 4 384 1927

# The CABLE Connection

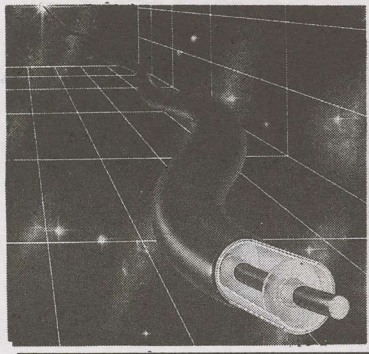

## On The Cheap

"How many homes must I serve to be profitable?" is a typical first question asked by someone contemplating a "mini-cable" system as we described in SF26 and 27.

The premise of mini-cable is simple enough: Locate an area (a community, section of a community, settlement) where terrestrial TV is inadequate. Then locate as close to the community as possible a site (headend) where because of terrain (greater elevation, lack of shadowing by nearby hills) you have good reception on the terrestrial signals. Now the trick is to cable the stretch from the headend to the area to be served, and then route cable around the community to serve each residence.

Once you have quality off-air signals, they can be amplified, perhaps frequency converted, and then combined together to a single cable that runs into the residential area. The (often remote) headend site may not have AC power available (they seldom do!) but this is not a major problem - you can utilise the coaxial cable that leads into the community to duplex back to the headend 60VAC and there it can be run into a transformer to produce 230-240 volt AC to operate the headend equipment. Duplexing of 60VAC is a common practice in all cable systems and is in fact the method used to power cable line amplifiers within the distribution plant proper.

By frequency converting the off-air signals to 100 MHz and below you are able to go further with the cable signals without additional amplification. Most TV sets will tune the frequency region 45-90 MHz without a problem and within this range there is room for 6 TV channels spaced at 7 MHz intervals (1). As shown in SF26, if you elect to confine your cable carriage channels to the region between 45 and 100 MHz, the amplified signal power created at the headend will allow you to go considerable distances without additional

1/ 48.25, 55.25, 62.25, 69.25, 76.25 and 83.25 MHz.

2/ With all channels below 100 MHz, distances of 487 metres in RG/6, 1,353 metres in cable TV grade 1/2" aluminium sheathed cable.

3/ Or at 450 MHz, the plant could extend 747 metres before an amplifier was required.

amplification (2). This is based upon leaving the headend with a modest +108 dBuV (48 dBmV) after amplifying and combining the TV channels in the system.

If you elect to leave the off-air channels on their off-air frequencies, chances are you will have one or more of the channels in Band III (174-230 MHz). The penalty paid for leaving them "in place" is the greater cable losses at these frequencies. For example, in 1/2" aluminium cable the maximum cable length for our sample system before re-amplification is 1,353 metres at 100 MHz and 870 metres at 230 MHz (3). By placing all of the amplification "power" at the headend and making the initial cable plant totally "passive" you avoid cable line amplifiers within the plant.

The trade offs here are as follows:

1) By staying below 100 MHz, you are limited in bandwidth (number of channels)

2) Your headend off-air signal processing equipment will typically be heterodyne processing grade which will cost approximately A/NZ\$900 per channel whereas on-channel "strip amplifiers" will be nearer to A/NZ\$300 per channel.

Cable line amplifiers of suitable quality covering the frequency range 54-450 MHz cost approximately A/NZ\$300 each. If you can build the initial plant without these amplifiers you save money here. At the same time, you are spending more per channel for the headend heterodyne processors. However, with heterodyne processors you can safely "stack" channels on adjacent frequency assignments (such as 55.25, 62.25, 69.25 and so on) without adjacent channel interference problems. Most strip amplifiers are not of adequate quality to allow you to safely utilise adjacent channels on the cable system. Each system requires individual calculation to determine which way is the least expensive way to launch a system.

In the case of using cable TV techniques to bring reception into an area without frequency conversion (i.e., off-air signals transported on their original channels) you will have significant unused bandwidth for future expansion of services. Any band I or III channels not in use on your system can be later filled with satellite or other services using a modulator (fed by a satellite receiver) on the appropriate channel(s). However, by electing to keep all signals below 100 MHz initially, and keeping the entire plant passive, you leave open your options for expansion of the system's bandwidth at a later date. When you do decide a market exists for satellite channels beyond those you can place between 48 and 100 MHz, cable line amplifiers would be installed within the plant at locations where required. In this situation the plant passive portion is in place and functional - all you are doing is increasing the bandwidth by adding one or more amplifiers to support cable carriage above 100 MHz.

### How Many Homes?

Let us assume a 3 channel off-air headend with heterodyne processors on each channel; with antennas, a shelter and signal combining the budget would be close to A/NZ\$4,000 if you do the installation work yourself. Now let us assume a 1/2" cable run extending over 1,300 metres passing 50 potential subscriber homes. At \$2.30 per metre the cable will cost you \$2,990. If we assume 25 line taps (two or four outputs each) with 1/2" connectors we have another \$700. Finally there is the power supply to send 60VAC back up the cable to the headend, and a transformer at the headend to get us back to 230/240 volts to operate the cable equipment. This will cost another A/NZ\$750.

These are the basic parts to build the system and it comes to \$8,440. There is no labour included here - you have to dig a trench to bury the cable or otherwise install the cable above ground. If you have streets or driveways to cross (under or over) you will need to thrust (bore) each and use alkathene or PVC as a "conduit" to run the cable beneath a paved surface. If you are very clever and can locate equipment to do this you could get by ready to serve 50 homes for as little as \$10,000. Or to put it another way, for \$200 per home (passed) initial cost.

That is \$200 per "potential home" (a potential home is one that is passed by the cable system but not necessarily willing or financially able to subscribe). If the area is truly deprived of adequate off-air television, a reasonable expectation is that 50% or the homes would

subscribe (25; in fact you should survey the homes before you do any serious planning!).

Now, what might you charge for the service? At this point the cable service is inside of a tap at the street in front of (or behind) the home. You still need to run inside to the TV set(s) with RG/6. This will cost you around \$30 per home for materials. So if you charge anything less than \$30 to "connect" to the service, you are losing money on the installation.

Suppose you charged \$50 to connect and then \$15 per month for the service. And 25 homes take up the service. In the first year you collect \$1,250 for the installations (which will be 25 x \$20 or \$500 as "profit") and \$4,500 for service (25 homes x \$15 per month x 12 months). Without actually taking any money out of the system for your own labours, you will pay off the original \$10,000 cost in two years and two months. Or to look at it in a more positive way - in five years the system will have paid for itself and returned to you \$12,750 in gross revenues. If the numbers seem less than appealing, remember this is for only 25 homes at \$15 per month each. An individual or firm that built ten such systems and managed them from a central location would take in \$127,500 in "profit" in five years. Perhaps that is a more appealing number

Now suppose you wanted to add one or more satellite channels to the three off air signals: What might this do to costs and earnings? We will explore this in some detail in SF28.



# ORBITRON

## Antenna Specifications

	Dia	F/D	Gain dBi	
Model	M	Ratio	4.2GHz	12.2GHz
SX8.5	2.5	.36	39.2	46.6
C10	3.0	.30	40.5	48.2
SX12	3.6	.36	42.2	49.5
O16	4.9	.30	44.9	52.1

distributed by

## Sciteq Pty Ltd

ACN 009 235 090

33 Kentia Loop, Wanneroo, WA 6065, AUSTRALIA

E-Mail: [pmerrett@omen.com.au](mailto:pmerrett@omen.com.au) <http://www.omen.com.au/~pmerrett>

Phone: ++61 9 306-3738

Fax: ++61 9 306-3737

# SatFACTS Pacific Ocean Region Orbit Watch: 15 December 1996

Copyright 1996: SatFACTS, PO Box 330, Mangonui, Far North, New Zealand (Fax: 64-9-406-1083)

Free-to-Air 57E to 80E	
Sun Music	57E/703 1400RHC
Sun Movies	57E/703 1342RHC
Sky News	57E/703 1257LHC
BBC World	57E/703 1224LHC
Sun TV	57E/703 1220RHC
AsiaNet	57E/703 1170RHC
WorldNet	57E/703 1100RHC
NEPC	57E/703 1090/LHC
TVi	57E/703 1020LHC
Muslim TV	57E/703 975LHC
Discovery	68.8/Pas4 Vt/1365
ABN	68.8/Pas4 Hz/1365
CCTV4	68.8/Pas4 Vt/1314
Sony Enter. TV	68.8/Pas4 Hz/1240
Doordar. India	68.8/Pas4 Vt/1116
CNNI	68.8/Pas4 Hz/1065
TNT/Cart.	68.8/Pas4 Hz/1040
ATN	68.8/Pas4 Vt/972
BBC World	68.8/Pas4 Hz/1350
MTV Asia	68.8/Pas4 Hz/965
TK Rossija	80/S13 1475RHC
VTV4	80/S13 1275RHC

Free-to-Air 80E to 113E	
AST	85/S3 1275RHC
Dub'l II	90/S6 1475RHC
Orbita II	90/S6 1275RHC
Dub'll I	90/S6 1234RHC
Orbita I	90/S6 1208RHC
Doordar.7	93.5/In2b 1285/Vt
Doordar.1	93.5/In2C 1160/Hz
Doordar.9	93.5/In2c 1080/Hz
Doordar.8	93.5/In2b 1050/Vt
Doorda10	93.5/In2b 1010/Vt
Doordar.2	93.5/In2c 980/Hz
Orbita II	96.5/S14 1475RHC
CCTV4	96.5E/S14 1325RHC
TV Shopping	100.4/As2 1490/Vt
TV Mongolia	100.4/As2 1470/Hz
Henan, China	100.4/As2 1430/Hz
Guandong China	100.4/As2 1310/Hz
CCTV4	100.4/As2 1190/Hz
RTPi	100.4/As2 1170/Vt
European Bouquet FTA DVB	100.4/As2 1150/Hz
Dub'l II	103/S21 1475RHC
ART	103/S21 1275RHC
SCTV	113/C2 967/Vt

Free-to-Air 113E to 145E	
CFI	113/C2 990/Hz
MTV Asia	113/C2 1030/Hz
TPI	113/C2 1070/Hz
TV Indosair	113/C2 1090/Vt
ABN	113/C2 1120/Hz
ANteve	113/C2 1130/Vt
CNNI	113/C2 1183/Hz
GMA	113/C2 1230/Hz
TV3	113/C2 1250/Vt
ATVI	113/C2 1270/Hz
TVRI	113/C2 1310/Hz
RTM	113/C2 1330/Vt
RCTI	113/C2 1350/Hz
CNBC	113/C2 1530/Hz
Colour Bar Tests	128/Jcsat3 1170/Hz, 12.280/Hz 12.386/Vt
Laos TV	130/R41 1375LHC
Orbita-I	140/S7 1475RHC
NTV	140/S7 1425RHC
Music Asia	142.4/R42 1475LHC
RAJ-TV	142.4/R42 1425LHC
ViJay TV	142.4/R42 1325LHC
EM TV	142.4/R42 1272LHC
Dub'l-I	145/S16 1275RHC

Free-to-Air 145E to 180E	
CNNI	168/Pas2 1183/Hz
CNN Feeds	168/Pas2 1155/Hz
NHK	168/Pas2 1114/Hz
TV Shopping Feeds	168/Pas2 1400/Hz 174/I701 984RHC
Feeds	174/I701 973RHC
Feeds	177/I702 984RHC
Feeds	177/I702 963RHC
Feeds	180/I511 1430RH
WorldNt	180/I511 1175RH
RFO	180/I511 1105RH
Feeds	180/I511 1020LH
Feeds	180/I511 984RHC
<b>ENCRYPT/MPEG SERVICES</b>	
Sky Racing(a)	100.4 1130/Vt
European Bouquet	100.4 1150/Hz
Star TV (b)	100.4 1250/Vt
APT (b)	100.4 1351/Hz
WTN (b)	100.4 1363.6/H
Star Chinese (a)	100.4 1390/Hz
Star TV (b)	100.4 1410/Vt
Star TV (c)	100.4 1450/Vt
ESPN (d)	113/C2 1030/Hz

HBO Asia (d)	113/C2 1150/Hz
TNT + (d)	113/C2 1390/Hz
Discovery (d)	113/C2 1430/Hz
Star Indovis'n (c)	113/C2 1570/Hz
Star Indovis'n (c)	113/C2 1650/Hz
ABC5, RPN9 (c)	142.4/ R42 1375LHC
Galaxy (c)	156/B3 12.437Hz
Galaxy (c)	156/B3 12.373Hz
China PowRvu (b)	168/Pas2 1433.5/ Vt
HK MPEG 1.5 (c)	168/Pas2 1426/Hz
Discovery (c)	168/Pas2 1374/Hz
MTV Asia (a)	168/Pas2 1346/Vt
ESPN (a)	168/Pas2 1288/Vt
California PowRvu (b) (c)	168/Pas2 1249/Hz
TNT + (a)	168/Pas2 1218/Vt
Fox/Prime (c)	168/Pas2 1161/Vt
Filipino Ch. (b)(c)	168/Pas2 1060/Hz
NBC HK	168/PAS2 1057/Vt
HK PowRvu (b) (c)	168/PAS2 1002/Vt
TCS Singapore (b)	168/Pas2 967/Hz

**No home DTH subscriptions**



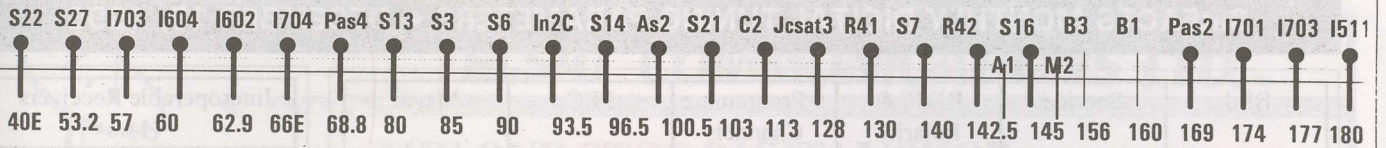

**OPTUS B3  
156E  
(Ku only)**

(B-Mac)	1425/Vt
Central ABC HACBSS	1393/Hz B-Mac
Vic. ETV	1361/Vt CryptV.
Imparja TV	1329/Hz B-Mac
(B-Mac)	1297/Vt
Net 9, Sky specials	1233/Vt B-Mac
Central ABC HACBSS	1201/Hz B-Mac
	1169/Vt
Galaxy	1137/Hz Irdeto Mpeg 2
	1105/Vt
Galaxy	1073/Hz Irdeto Mpeg 2
Golden West	1041/Vt
	1009/Hz
	977/Vt

**RUSSIAN Inclined Orbits**  
 80E/ +/- 2.3  
 85E/ +/- 2.8  
 96.5E/ +/- 1.5  
 103.2E/ +/- 2.1  
 130E/ +/- 1.0  
 140E/ +/- 4.4 (?)  
 142.4E/ +/- 0.9E  
 145E/ +/- 3.9

Encrypted (to left)

**OPTUS B1  
160E  
(Ku only)**

Net 9, Sky feeds	1425/Vt B-Mac
Data	1402/Hz
QSTV	1377/Hz B-Mac
NE ABC HACBSS	1370/Vt B-Mac
NE SBS HACBSS	1344/Vt B-Mac
SE SBS HACBSS	1339/Hz B-Mac
SE ABC HACBSS	1313/Hz B-Mac
Sky Channel	1296/Vt B-Mac
ABC Radio	1276/Hz (digital)
OmniCast	1270/Vt (FM/FM)
ABC feeds	1247/Hz Pal
Net 7	1244/Vt E-Pal
Net 9 feeds	1219/Vt Pal&Ntsc
	1214/Hz
Net 10	1182/Vt E-Pal
Net 9	1180/Hz E-Pal
Net 10 feeds	1155/Vt Pal
Net 7	1120/Vt E-Pal
Net 9 feeds	1091/Vt Pal
CAA air to ground	1009/Vt Nbfm
CAA air to ground	977/Vt Scpc(fm)

**PAS-2  
169E  
(C + Ku)**

CCTV3,4	1433.5/Vt (Sa9223)
Abn/Ctn/ Cctv/Nbc	1,426/Hz (Sa9222)
Value Ch.	1400/Vt
Discovery PowerVu	1374/Hz (Sa9223)
MTV Asia	1346/Vt B-Mac
ESPN	1288/Vt B-Mac
MPEG-2 PowerVu Sylmar	1249/Hz (Sa9223)
TNT+ (1/2Tr)	1218/Vt B-Mac
CNN+ (1/2Tr)	1183/Hz
FoxSports	1161/Vt (Sa9222)
NHK	1115/Hz
Filipino Channel	1060/Hz (GI Mpeg)
NBC Mux MPEG	1057Vt (Pace)
MPEG-2 PowerVu HonKong	1002Vt (Sa9223)
TCS Sing.	967/Hz

**PAS-2 Ku**

PowerVu	12,415V
H-Life	12,520V

**MeaSat 2  
148E**

Tests	1167/Vt
-------	---------

**Intelsat 701  
174E**

Feeds	963
Feeds	984

**Intelsat 703  
177E**

AFRTS (1)	973 B-Mac *
Feeds	984

\* LHC; (1) PowerVu testing underway

**Intelsat 513  
177W**

Feeds	963
Feeds	984

**(513 Ku)**

Service	RF Freq.
US Nets	10.980V
NBC	11.015V
Feeds	10.510V

**Ku Services**  
 Intelsat Ku band services shown here are boresighted to Japan and nearby Asia, have not been reported south of equator. At boresight, signals of < 2m levels.

**TDRS5 / 174.3W**

Fuji TV	1305 Hz
BBC World	1163Hz MPEG

**UPCOMING SATELLITE LAUNCHES**  
 January '97/JCSAT-4 to 150E  
 January '97/ Indostar (S-band) to 106E  
 January '97/ ApStar 2R to ??E  
 February'97/ I1801 to 174E.

**Intelsat 511  
180E(W)  
+/- 2.9deg.**

TVNZ	964/Ntl 3000
TVNZ	972/Ntl 3000
TVNZ	980/Ntl 3000
TVNZ	988/Ntl 3000
Occ Vid.	1,020**
9 Aust.	1,025
Canal +	1,054 **
RFO Tahiti	1,105
Asian	1,130
World-net	1,175
NHK	1,225**
ABC Oz	1,256
7 Oz	1,274
10 Oz MPEG	1,385 (PwRvu)
Keystone	1,432

\* RHC & LHC  
 \*\* LHC only

**(511 Ku)**

NHK	11.135H
CBS	11.475H
CNN	11.508H

**TDRS5 "north" only**

(a) B-MAC or Starcrypt encrypted, no access available.; (b) MPEG format, requires special receiver; (c) MPEG, encrypted, access may be possible (d) B-MAC, subscriptions available in some geographic areas. No indication - MPEG DVB FTA.

MC Ver 1.0  
SOFTWARE 1.63

BUSH WASH  
NOV 28  
1.63

SatFACTS MONTHLY DIGITAL TUNING PARAMETERS ♦ DECEMBER 15, 1996

Bird	Service	RF/IF & Polarity	# Programme Channels	FEC	Msym
As2	EBB	4000/1150Hz	5TV, 13 radio, MediaNet (a)	3/4	28. 125
	StarAsia CA test	3700/1450Vt	up to 6 TV (b)	3/4	28. 100
	StarAsia tests	3740/1410Vt	up to 6 TV (b)	3/4	28. 100
	World TV News	3786.4 /1363.6Hz	1TV, 1 aux	3/4	8. 448
	STAR + service	3900/1250Vt	5TV, 1 radio (c)	3/4	28. 100
	APT News	3799/1251Hz	1TV, 1 aux	3/4	5. 632
Palapa C2	Star Indovision	3500/1650Hz 3580/1570Hz	6+ TV 6+TV	7/8 7/8	26.85 26.85
R41/142.4E	DSP, Inc. Philippines	1375LHC	3TV (d)	3/4 (when PowerVu)	4.88 (P-Vu)
PAS-2	TCS Singapore-SA	4183/967Hz	2TV	1/2	6. 62
	Discovery Singapore-SA	3776/1374Hz	6TV	3/4	19. 850
	NBC HK-Philips	4093/1057Vt	7TV (e)	3/4	29. 473
	SA California PowerVu	3901/1259Hz	7TV (f)	3/4	30. 800
	SA California PowerVu	12415/1115 Vt	7TV (f) (g)	3/4	30. 800
	CCTV China PowerVu	3716.5/ 1433.5Vt	2TV (h)	3/4	19. 850
	SA HK PowerVu	4148/1002Vt	7TV (i)	2/3	24. 430
Optus B3	Galaxy	12.438Hz 12.373Hz	20+ TV (j)	3/4	29. 473

Interoperable Receivers (1)
NTL, DGT400(2), DVR500, IRD520, SK888
NTL(b)
NTL(b)
SA winner NTL on APTV #5- NTL Not on WIN
NTL, Comstream
Pace DVS211 (not yet available in quantity)
SA9222 today (temporary); PowerVu "soon"
S-A PowerVu
S-A PowerVu
NTL, DGT400(2), DVR500, IRD520
S-A PowerVu
S-A PowerVu
S-A PowerVu
S-A PowerVu
DGT400, IRD520, SK888 (3)

Handwritten notes on the left margin, possibly "NTP" or similar.

1) Interoperable receivers: Receivers (IRDs) which have proven through repeated use to be capable of reliable digital reception for the programme services listed. 2) Pace (Galaxy) DGT400 units will function on these services ONLY if they have NOT been over-the-air "upgraded" to include the "programme Censorship" classification function. 3) Access to Galaxy programming requires a smartcard from Galaxy; such cards reportedly will also function with these receivers. Otherwise preview channel and TVSN are only services FTA. (a) (1) Deutsche Welle, (2) MCM, (3) RAI International, (4) RTVE, (5) TV5 Paris; Radio channels: (1) DW #1 stereo, (2) DW#2 (stereo), (3) DW#3 (stereo), (4) YLE (left), RCI (right), (5) SRI(l), WRN(r), (6) REE, (7) DW#1 (stereo), (8) DW#2 (stereo), (9) DW#1 (stereo), (10) NN RA6, (11) NN RA8 + MediaNet [Internet] with Vertical Blanking Interval of DW TV on video programme ch. 1 (see SF#27, p. 14, 32); (b) Star Asia using their own version of MPEG(2) is testing up to 6 programme channels on these two transponders; conditional access when employed requires Pace DVS-211 receiver and companion smartcard. Occasionally testing can be seen on DMV/NTL 3000 without conditional access. (c) Video is subject to some variation but nominally includes: (1) Star + (Japan; NTSC), (2) VIVA Cinema (Philippines: NTSC), (3) CNBC (actually, test with static slide), (4) (horse) racing feeds (very occasional) to 'TCNA', (5) Sky News (London), (6) Star Radio; (d) At press time this remains SA MPEG 1.5 at 1375LHC on 142.4E but conversion to PowerVu is scheduled. At this time (1) ABC-5 (English), (2) RPN-9 (English), (11) test video; (e) (1) CNBC, (2) CNBC, (3) NBC Asia, (4) Colour bars - future use, (5) CNBC, (6) NBC Asia, (7) colour bars - future use [note: CNBC and NBC split feeds by programme channel for differing target area time zones (India, for example, is time-offset from Australia/New Zealand)]; (f) (1) CMT (NTSC), (2) CBS feeds, others; (3) NBA feeds, others; (4) EWTN (NTSC), (5) BBC World (NTSC), (6) Bloomberg Financial (NTSC), (7) Golf Channel (NTSC), (8) "Open"; (g) Ku feed of California PowerVu bouquet had disappeared from PAS-2 November 4 and may not return (was a test); (h) (1) CCTV4 (NTSC), (2) CCTV3 (NTSC) [these 2 services very difficult to receive because of low eirp through transponder - if you can resolve these, your dish is working VERY WELL!]; (i) (1) CTN News, (2) CTN Entertainment (conditional access), (3) TVBS HK and other feeds (NTSC), (4) CCTV-4 (NTSC), (5) NBC Asia, (6) ABN; (j) Galaxy access requires subscription smartcard which works with intended DGT400 IRD and from reports with Panasat IRD520 as well. Without smartcard DGT400, IRD520 and perhaps SK888 will also access free to air programme preview channel (not always operating) and TVSN shopping channel.



## TELSAT COMMUNICATIONS LTD.™

### THE ONE-STOP DIGITAL SHOP

**NOKIA DVB-9500S MultiMedia - Demo unit avail - Ex Factory Stock Jan,'97.**

**PANASAT IRD-520 - Ex Stock**

**SCIENTIFIC ATLANTA D9223 IRD's - Immediate delivery & Subscriptions**

**Introducing the DIGISKAN SK-888 - Due Dec. **THE FIRST DVB IRD UNDER NZ\$1000+ GST. Reserve your unit NOW - destined to be a WINNER.****

**Call TELSAT for ALL your WISI SMATV & CATV Product requirements**

**NEW CHAPARRAL 20K Digi ready MicroPak    Cal-Amp Digi ready MiniMag II+**

**Xmas SPECIALS - Mark Long's The World of Satellite TV in Asia. NZ\$15 plus Dr Frank Baylin's Home Satellite TV INSTALLATION. NZ\$40 (Both post paid NZ - limited stocks)**

Visit our WEB site <http://www.nethomes.com/telsat/>

Email [telsat@intec.gen.nz](mailto:telsat@intec.gen.nz)

**Thank you for all your support during 1996 - we hope to have the pleasure of serving you again in 1997. Christmas & New Year wish's to you all from the staff at TELSAT. We look forward to seeing you at the SPRSCS-97.**

17 Westhaven Grove, P.O. Box 1537, Palmerston North, New Zealand  
Tel: (06) 356-2749 Fax (06) 355-2141 Int'l +(64) 6-355-2141 Cellular (021) 454-945

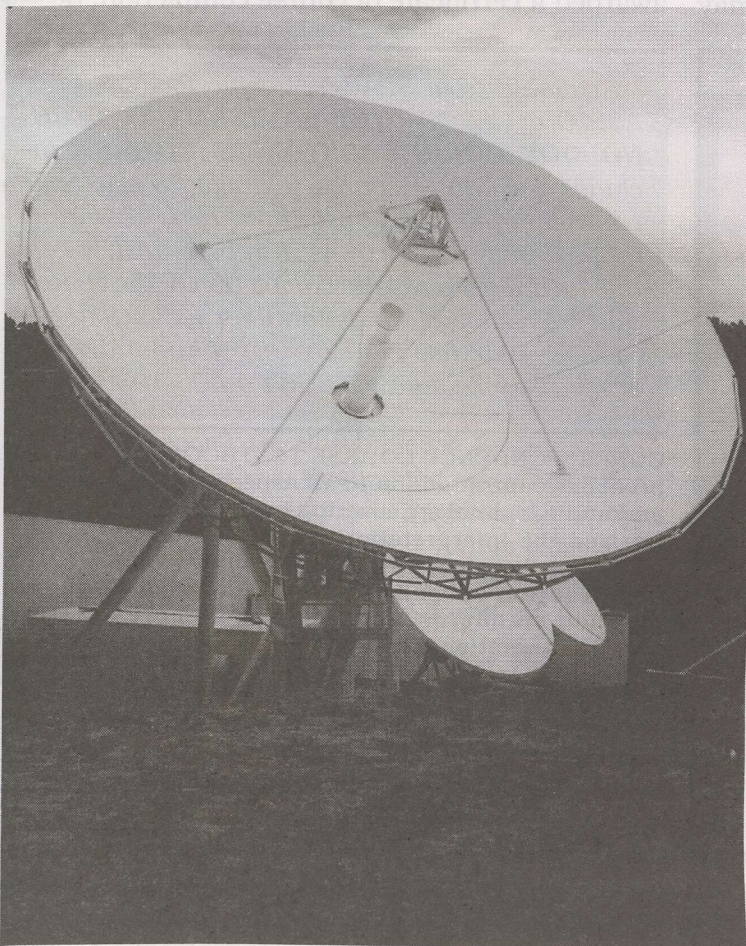

### NEW ZEALAND'S FIRST PRIVATELY OWNED TELEPORT

can put you in touch with  
C and Ku satellites serving  
the South Pacific.

TV feeds (in and out), radio networking  
feeds (in and out), Internet access - all  
through Intelsat rated dish antennas from  
13m and down in size.

Microwave links to most of Auckland  
designed for each user/client. Clearly, the  
Telecom alternative!

**New Zealand Teleport Holdings Ltd.**  
Whangaparaoa

Bryon G.G. Evans at tel/fax 64-9-424-0841 /  
Mobile 025-789-160

## SATELLITE TV TECHNOLOGY CORRESPONDENCE COURSE

The official technician certification course of the SPACE—Pacific satellite trade association

**THE SATELLITE TV TECHNOLOGY CORRESPONDENCE COURSE** is a complete home/office study program that has been expressly developed for students and professionals who wish to expand their knowledge and technical skills. The course consists of the *Satellite TVRO Handbook* and *Satellite TV Technology Overview* videotape, supplementary text materials on the latest technical developments in the Asia/Pacific Region, four take-at-home exams, a report card, and a certificate upon course completion. Students are able to proceed at their own pace and receive clarification from the course leader concerning specific course topics or ask questions on related topics.

**THE SATELLITE TV TECHNOLOGY CORRESPONDENCE COURSE** is taught by Mark Long, Founding Publisher of the *World Satellite Almanac*. Each of the four major course exams are mailed to registered students upon receipt of their written request for the exam materials. Completed exams are returned to the course leader for grading and suggestions for further study to clarify those points on each exam which the student may

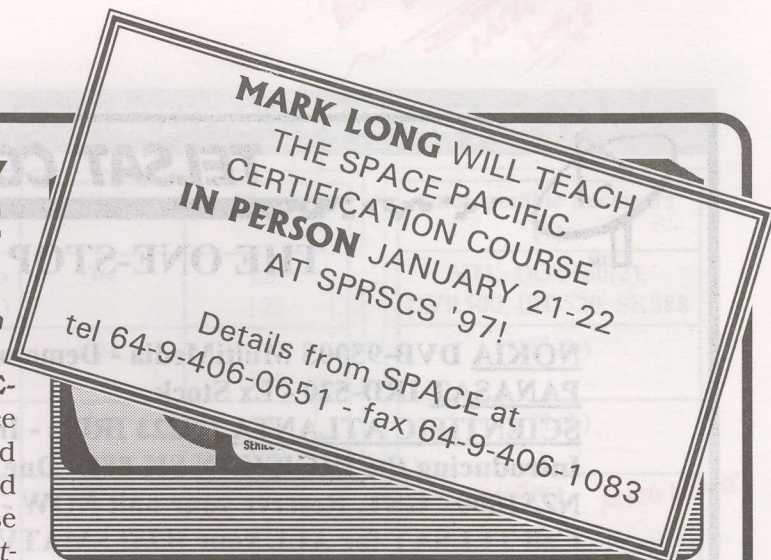

**CORRESPONDENCE COURSE VIDEOTAPE (ABOVE):**  
**PART ONE: THE SPACE SEGMENT:** Orbits & Orbital Assignments; Frequencies; Satellite Frequency Bands S/C/Ku/Ka; FSS vs BSS Satellite Frequency Assignments; Satellite Transponders; Satellite Polarization Formats; Satellite Communication Subsystems; and Interpreting Satellite Coverage Maps. **PART TWO: THE EARTH SEGMENT:** Antennas & Feedhorns; LNBs; Receivers and IRDs. **PART THREE: VIDEO AND AUDIO PROCESSING:** Video Standards - NTSC, Pal And Secam; HDTV; Video Encryption; Digital Video Compression; Digitizing Video; MPEG & MPEG DVB; MPEG Compression Techniques; MPEG Data Rates; Transmitting MPEG Via Satellite. **PART FOUR: INSTALLING SATELLITE RECEIVING SYSTEMS:** Antenna & Feedhorn Alignment; Installing Digital Receiving Systems. 60 minutes, PAL-VHS.

not have fully mastered. Upon successful completion of the four major exams, each student will be awarded a certificate of course completion.

## THE SATELLITE TVRO HANDBOOK

written & compiled by Mark Long  
 Founding Publisher of The WORLD SATELLITE ALMANAC

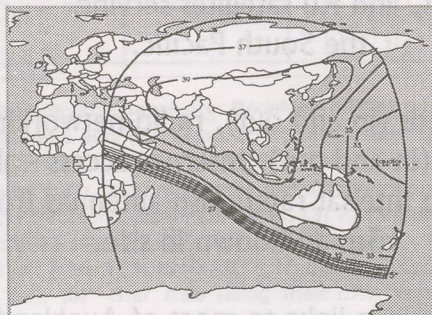

- ✓ INTERPRETING SATELLITE FOOTPRINTS
- ✓ SATELLITE FREQUENCY ASSIGNMENTS
- ✓ VIDEO & HDTV STANDARDS
- ✓ MPEG DIGITAL COMPRESSION
- ✓ TVRO SYSTEM DESIGN
- ✓ INSTALLATION PROCEDURES
- ✓ TRACKING INCLINED ORBIT SATELLITES
- ✓ SMATV SYSTEM OVERVIEW
- ✓ SOLAR & RAIN OUTAGES
- ✓ TERMINOLOGY GLOSSARY

THE OFFICIAL TECHNICIAN CERTIFICATION TEXTBOOK OF SPACE Pacific Satellite Program Access Committee  
 The trade association of private satellite-direct systems in the Pacific Ocean Region

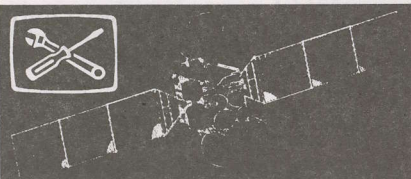

Available from SPACE—Pacific for NZ\$ 650, A\$600, or US\$ 394, **THE SATELLITE TV TECHNOLOGY CORRESPONDENCE COURSE** includes the basic course textbook, a one-hour course videotape, supplementary text and graphic materials, exams, a report card, a certificate upon successful completion of the course and all shipping and handling fees. Contact: SPACE—Pacific, PO Box 30, Mangonui, Far North, New Zealand. Fax: 64-9-406-1083

**CORRESPONDENCE COURSE TEXTBOOK (Left):** A comprehensive introduction to all aspects of satellite video and audio technology covering basic satellite terminology and the interpretation of satellite coverage maps; satellite subsystem overview; satellite telecommunication frequency assignments; video transmission and encryption standards, digital video compression and HDTV; international satellite earth station component guide; how to install satellite TV receive only (TVRO) systems, modified polar mount alignment; inclined orbit satellite tracking guide, SMATV system design; the effects of solar outages and rain fades on satellite system design, and a complete lexicon of satellite terminology. The official technician certification course textbook of SPACE Pacific. 212 pages illustrated.

# WITH THE OBSERVERS

The Indovision program guide for the month of November may help those with Indovision B-MAC decoders feel better about their present investments. The background is as follows:

Late in September (SF26, p. 6) STAR Southeast Asia began transmitting a bouquet of digital services using a Palapa C2 beam that is primarily directed at Asia. Reception of the bouquet (1570 and 1630 IF, horizontal) is only probable when the same site can also produce P5 reception from CNBC at an IF of 1530 (Hz). This eliminates virtually everyone south of (northern) Queensland and (northern) NT unless some very large dishes are employed.

There has been concern that with the new Indovision digital service, subscribers to the B-MAC analogue (TNT/Cartoon, HBO Asia, Discovery and ESPN) services could one day awaken to find this package "turned off." Numerous "stories" have swept the industry to this effect. The Indovision Guide for November writes:

*"Over the next few months we will be adding several new channels to the digital service, which will be brought to you at no extra cost. BBC World and CNN will have live news coverage and documentaries. MGM Gold brings you great movie classics and new releases from MGM and United Artist Studios. Film Indonesia is the only 24 hour Indonesian movie channel.*

*"We will be writing to you with a special offer to take up the new digital offerings. If you'd like to continue receiving your current service, you don't have to do anything at all. However, we believe you'll find the hours of quality film and entertainment our enhanced service offers simply unbeatable value for money."*

## What Indovision is Promoting on the Digital Bouquet

"Soon, Indovision will offer you 14 channels of non-stop quality entertainment and international film action. You'll enjoy TWO film channels, 24 hours a day - HBO and STAR Movies with over 170 great Western films each month. What's more, these movie channels are all subtitled in Bahasa and available exclusively through Indovision. STAR Sports will bring you exclusive live coverage of the top sporting events. There are 7 further channels (including) CNBC and NBC (Asia), children's programming, music and drama ..."

**WITH THE OBSERVERS:** Reports of new programmers, changes in established programming sources are encouraged from readers throughout the Pacific and Asian regions. Information shared here is an important tool in our ever expanding satellite TV universe. Photos of yourself, your equipment or off-air photos taken from your TV screen are welcomed. TV screen photos: If PAL or SECAM, set camera to f3.5-f5 at 1/15th second with ASA 100 film; for NTSC, change shutter speed to 1/30th. Use no flash, set camera on tripod or hold steady. Alternately submit any VHS speed, format reception directly to SatFACTS and we will photograph for you. Deadline for January 15th issue: January 3 by mail (use form appearing page 34), or 5PM NZST January 4th if by fax to 64-9-406-1083.

## AT PRESS DEADLINE

Measat 2 which launched mid-November to 148E had test carrier on 1168 IF, Vt. December 6th as reported by Garry Cratt (NSW). Signal level varied as power to bird was turned up and down. This satellite has 6 x 72 MHz (equal to 12 x 36 MHz) C-band transponders on board, footprint that includes east coast of Australia. Reports are solicited to SatFACTS.



CCTV (4) on AsiaSat 2 in FTA PAL analogue (1183, Hz) is now carrying teletext although it may seem "gibberish" at times.

This seems to put to rest those "stories" for at least the time being. There has never been an official statement from Indovision concerning the future of the 4-programme-channel B-MAC service and while the Guide statement does not unequivocally state it will be around for the indefinite future, it certainly suggests no near-term changes are planned (i.e., "If

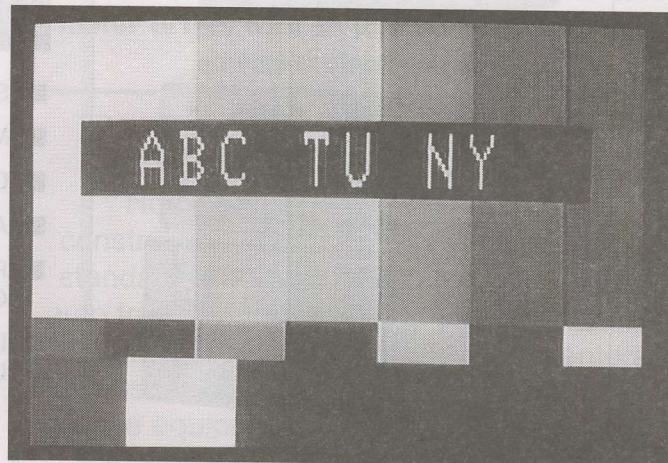

ABC (USA) is now vidiplexed and encrypted (some of the time) on 1180 on 1010 IF (audio 6.6).

# RELY ON PROMAX!

## YOUR leading performer in the TV and AUDIO business.

### PROMAX Signal Strength Meters for:

- FM    ■ UHF    ■ VHF
- SATELLITE    ■ CABLE TV

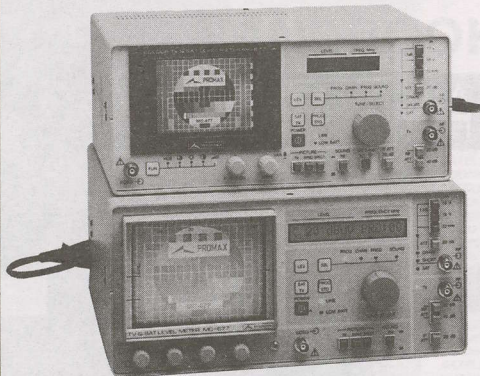
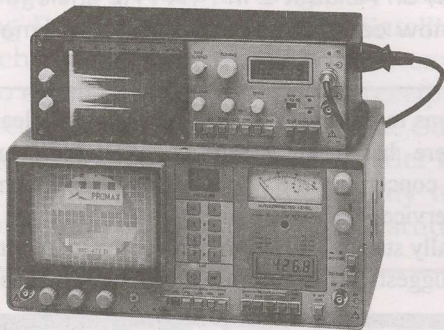

**Gough Technology** supply leading brands in their respective fields. With ISO 9002 certification, our customer sales and support service is guaranteed to meet your highest expectations.

**PROMAX** top quality test and measurement equipment:

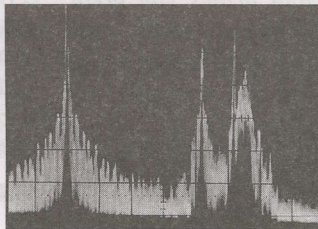

- SPECTRUM ANALYSERS
- MILLIVOLT METERS
- DISTORTION METERS
- AUDIO TESTERS
- PATTERN GENERATORS
- LOW DISTORTION LF GENERATORS

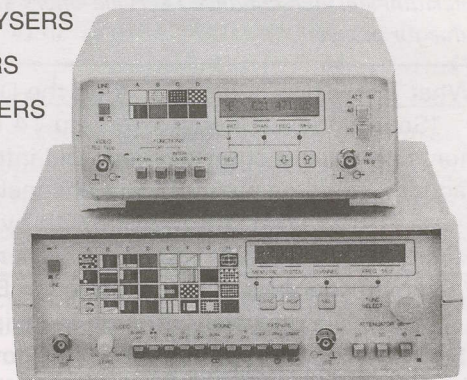

**Freephone 0800-80-20-20**

**Freefax 0800-68-20-20**

Email: [sales@goughs.co.nz](mailto:sales@goughs.co.nz)

**TELORC**  
REGISTERED  
SUPPLIER

**CHRISTCHURCH**  
245 St Asaph Street  
Christchurch, New Zealand  
PO Box 22073  
Fax 0-3-379 6776, Tel 0-3-379 8740

**AUCKLAND**  
349 Great North Road  
Auckland, New Zealand  
PO Box 68150  
Fax 0-9-378 4592, Tel 0-9-376 3174

**WELLINGTON**  
1 Jackson Street, Petone  
Wellington, New Zealand  
PO Box 38421  
Fax 0-4-568 4376, Tel 0-4-568 6675

**GOUGH**  
TECHNOLOGY

Precisely!

McAra

### Unusual Testing on JCSAT-3

Several observers report a strong C-band signal near 970 IF (vertical) from JCSAT-3 at 128E. The signal is non-analogue and it is possible it is some variant of MPEG or it could be tests for a new high speed Internet connection (see p. 10, this issue). Although the signal is (at press deadline) only transmitted on an irregular basis, it has been measured by several New Zealand observers in the signal level range of CNN from PAS-2. Additional observations and possible identity of the signal contents are sought.

you would like to continue receiving your current (B-MAC) service, you don't have to do anything at all.").

**Scratch Rimsat aka Agila** at 153E. Details not known but somehow two competitive Filipino satellite systems (Mabuhay and Agila) have "merged" into one and ex-Indonesian B2P leased by Mabuhay for use at 144E is now formally known as "Agila 1." Orbit slot at 153E is still to be used but not by Rimsat from 130E after all. Agila and Mabuhay both had new bird launches scheduled (144E, 153E) for first half of 1996; what will happen now firms have merged not yet announced.

**David Leach** (NSW) reports SCTV, formerly on C2 at 1190 Hz, has moved to 967 Vt and the picture quality at his location has dropped from P5 to P3. 967 Vt was previously in use for the Star TV FTA analogue service which was dropped in August.

**Jim Ruhe** (Honiara, Solomon Islands) reports RAJ TV on Rimsat R42 (142.4E) is P3 at his location (previously P5 from R41). Others intended for India also on R42, at his location, include Eagle Net at P2 (1325 IF) and Asia Music Television (ATN) at P3 (1465 IF).

Observers report that Gorizont S7 (140E) has changed characteristics, "not pulsating as much as previously." This could be a newer Gorizont shifted from 96.5E; can anyone confirm? Check video carrier 1420 IF, Russian, although audio may be "sound in syncs" (buried inside of video and requiring special aural detector).

### Horizontal Satellite

A proposal first floated late in 1995 by New Zealand's Television New Zealand technology arm BCL is back again with a twist. BCL had sought comments from industry suppliers concerning a plan to seek approval to use 12 GHz region frequencies to distribute on a terrestrial point to point basis analogue encrypted television signals as a fast start way to jump over the slow rollout and construction difficulties involved in building cable TV. BCL sought and was denied a contract to distribute (NZ) Sky Network pay TV programming using this technology. Now BCL is floating the concept of using the same terrestrial grade of service to distribute the (US based) Internet service to subscribers. The concept is that "cell transmitter sites" would cover a township or neighbourhood at 12 GHz, off-the-shelf 12 GHz dishes, LNBS and receivers would be used for subscribers to the service. BCL proposes to emulate the DirecPC service with a delivery speed in the 400 kbps region using this transmission system.

P  
A  
C  
I  
F  
I  
C

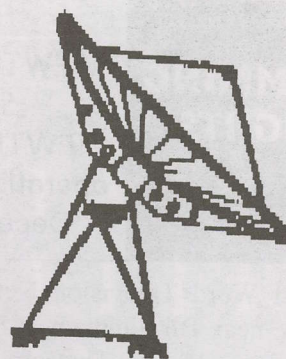

A  
N  
T  
E  
N  
N  
A  
S

Limited

*New Zealand's only stockist of preused transmit capable antennas - our stock presently consists of the following equipment:*

- 1 only 2° compliant 13 metre standard 'B' Vertex antenna with 4 port circular feed and Cassegrain sub-reflector
- 1 only 3° compliant 10 metre Scientific-Atlanta antenna with 2 port linear feed and Cassegrain sub-reflector
- 1 only 4.6 metre Andrew Ku Band antenna with 2 port feed and Gregorian sub-reflector
- 3 only 5 metre Sat Com Technologies transmit rated Ku band antennas
- 1 only 3.7 metre Comtech transmit antenna with Seavey transmit feed horn

**A selection of receive and transmit electronics including tracking equipment and motor drives with 15 to 50 ton azimuth and elevation jack screws.**

Pacific Antennas Limited is the major stockholder in New Zealand Teleport Holdings Limited, a teleport 90% construction completed. This facility has a standard 'B' 13 metre Vertex antenna with auto tracking capabilities. These companies can individually or collectively joint venture, lease, sell, operate or install all of the above equipment. We have the necessary licensing in place and the hardware has been installed for New Zealand's first privately owned independent standard 'B' uplink teleport. To learn more about business opportunities available, contact **Bryon G.G. Evans.**

### **Pacific Antennas Limited**

PO Box 265 • Whangaparaoa (Auckland), NZ  
Tel/fax 64-9-424-0841 / Mobile 025-789-160

## PROGRAMMING HIGHLIGHTS

✓ EWTN Christmas Specials (EWTN did begin operation 0000UTC December 8th)

The Eternal Word Television Network is operated from a facility near Birmingham, Alabama with a 24 hour programming schedule. The service being launched December 8 will be identical to the North American service (Galaxy 1R); a time shifted schedule is promised by the 31st of March but there are no details how the schedule will focus on the multiple time zones found across the Pacific Rim region.

EWTN programming is mostly in English but there are a few hours in Spanish (or subtitled in Spanish) each day. EWTN in its ten year history has grown from a part day mostly "folksy" service built around founder Mother Angelica into a very professional package. The primary appeal will be to Catholics but usually not to the exclusion of other Christians. Virtually all religions now have their own television dogma channel; EWTN has steered away from overt Catholicism, fund raising and other turnoffs often practised "by the competition." No doubt there is a strong desire to create converts to the faith but Mother Angelica has had the wisdom to subdue anything which might be a turnoff for non-Catholics in

## AV-COMM SATELLITE TV EQUIPMENT SUPPLIERS

See us at  
**SPRSCS'97**  
booth #204E  
for:-

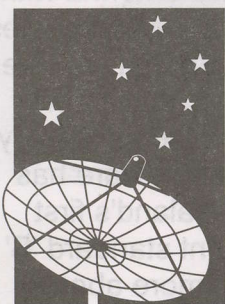

- \* Free Catalogue
- \* Technical Advice
- \* Special Offers
- \* New Products
- \* Demo Video

### AV-COMM PTY LTD

A.C.N. 002 174 478

198 Condamine Street, Balgowlah NSW 2093  
Tel: (02) 9949 7417/9948 2667 Fax: (02) 9949 7095  
VISIT OUR INTERNET SITE <http://www.avcomm.com.au>

## EWTN CHRISTMAS SPECIALS

### Sunday December 22

6PM Syd/8PM NZ: City That Forgot Christmas  
6:30PM/8:30PM: Go Look In The Manger  
7PM/9PM: Concert - Silent Night, Holy Night in Berlin

### Monday December 23

8AM/10AM: The Great Mr. Handel  
10AM/12N: The Abundant Life - Christmas Special  
11AM/1PM: In The Beginning - Birth of Jesus  
11:30AM/1:30PM: Gerbert - A Gift of Giving  
6PM/8PM: The Image of God - Christmas Special  
6:30PM/8:30PM: The Best Christmas Present Ever  
7PM/9PM: In Concert - Christmas in Nuremberg  
8:30PM/10:30PM: A Good and Perfect Gift  
9:30PM/11:30PM: Giotto - A Christmas Mystery

### Tuesday December 24

8AM/10AM: A Castle Christmas  
9AM/11AM: Go Look in The Manager  
9:30AM/11:30AM: St. Nicholas - Boy Who Became Santa  
1PM/3PM: A Saviour Is Born  
2PM/4PM: In Concert: Silent Night, Holy Night in Berlin  
6:30PM/8:30PM: How St. Nicholas Became Santa Claus  
7PM/9PM: James Galway's Christmas Carol  
8PM/10PM: Ralph Martin On Christmas  
8:30PM/10:30PM: A Saviour Is Born  
9PM/11PM: The Nativity

### Wednesday December 25

8AM/10AM: The Fourth Wise Man  
10AM/12N: Solemn Mass Christmas Eve Pope John Paul II  
5PM/7PM: Christmas Mass  
9PM/11PM: Carols For Christmas

### EWTN DETAILS

Format: S-A PowerVu 3901/1249IF Hz, channel 4, NTSC, FTA

Signal eirp: Pac Rim Beam (37 dBw most of Australia, 29 dBw New Zealand, 37 to 31 dBw PNG, 37-36 dBw Philippines, 35 dBw Japan/Korea/most of China, less than 25 dBw Tahiti)

Contacts: Sam Ranelli, EWTN, 5817 Old Leeds Road, Birmingham, Al (USA) 35210-2198 tel 205-956-9537, fax 205-956-0328, marketing department fax (schedule available) 205-951-0142

Receiver sourcing: Scientific Atlanta Australia tel 61-2-9542-3388, fax 61-2-9451-4432 (present delivery reported 4 weeks +)

the belief that viewers are human beings first and religious (or not religious) second.

The primary challenge is the Scientific-Atlanta D9223 receiver (or the newer 9234 Business satellite receiver and 9225 "economic alternative"). For a commercial installation, the funding should not be a problem; for individual DTH systems the real sales are unlikely to begin until S-A finally produces their long promised "DTH version PowerVu" (for which there is no hard date yet announced).

EWTN offers new sales opportunities for system dealers and it will be interesting to watch how the market copes with this newest service in PowerVu.



1 9 9 7

**BIGGER  
THAN  
EVER**

# AUSTRALASIAN CABLE & SATELLITE TELEVISION EXHIBITION

Tuesday 4 - Thursday 6 February 1997

Sydney Convention and Exhibition Centre, Darling Harbour, Australia

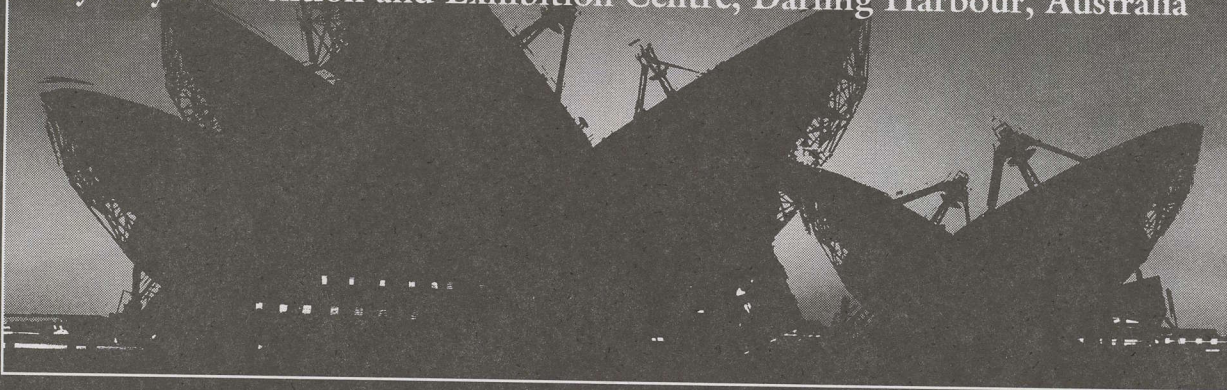

The market is keenly anticipating this major regional event on narrowcasting and broadcasting technologies

Official Publications:

Media Partner:

**PAY TV  
NEWS**

**ASIAPACIFIC  
SPACE  
REPORT**

Asia-Pacific  
**Satellite**

**Via Satellite**

**BEN**

**InDepth  
MAGAZINE**

**PNM** Fortnightly  
**ONLINE** Monthly  
**SOUNDWORKS** Bi-Monthly  
**ASIA-PACIFIC DIRECTORY**

**wireless**  
INTERNATIONAL

Premier Sponsor: **GI** General Instrument

Co-Sponsor: **PHILIPS**

**PHILIPS**

FOR MORE INFORMATION CALL +61 (0) 2 9210 5700 OR FAX +61 (0) 2 9223 8216

Please tick:

- send me information about Exhibiting in 1997
- send me information about Sponsorship for the 1997 event
- put me on the mailing list to be kept informed of the 1997 event

Mr/Ms/Dr .....  
First Name Surname

Position.....

Organisation.....

Main Line of Business.....

Address .....

Suburb.....State.....

Country.....Postcode.....

Telephone.....Fax.....

Organised by:

**A i C Exhibitions**

In association with:

**FANSS**

XS1065/SAFFI

# UNIDEN SATELLITE TELEVISION

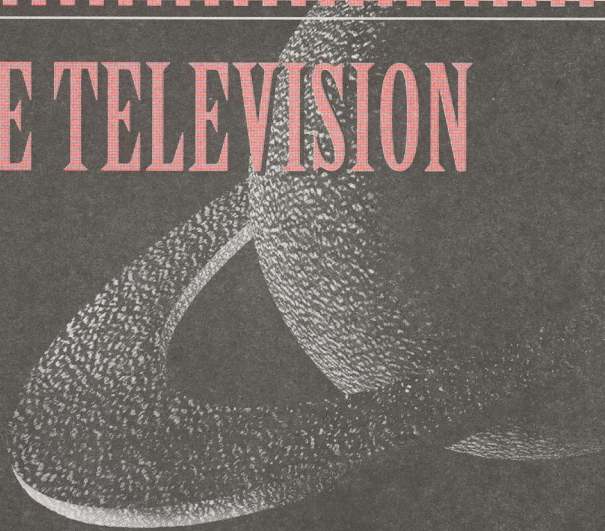

## *JUST IMAGINE...*

*Over thirty channels of free-to-air television from around the globe available throughout New Zealand. even in areas where present free-to-air or paid channels don't reach.*

## *THIS IS NOT A DREAM, It's a reality.*

*And it's available to your customers right now, with equipment costs that are probably a lot less than you would expect.*



*Uniden are about to launch their Satellite Television Package to dealers throughout New Zealand.*

*If you would like to find out how to profit from satellite television in New Zealand give Uniden a call.*

*After all, Uniden is one of the world leaders in satellite television technology.*

## UNIDEN SATELLITE TELEVISION

*Putting You Face To Face With  
A World of Entertainment*

**uniden®**

*a Clear Signal of What's Ahead*

*For more information Phone 0-9-273 8383 or Fax 0-9-274 0009*

*Uniden® is a registered trademark of the Uniden Corporation of Japan Ltd and is represented in New Zealand by Uniden (NZ) Ltd.*