

850AM 14-11-96

Bob Cooper's

NOVEMBER 15 1996

SatFACTS

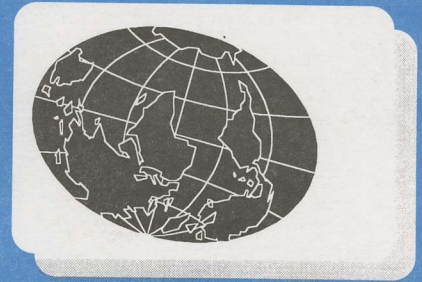

MONTHLY

Reporting on "The World" of satellite television in the Pacific Ocean Region

IN THIS ISSUE

**US\$48
DIGITAL
RECEIVERS!**

**HORST WIESER
FILIPINO
REPORT**

**INTERNET
SATELLITE
LAUNCH**

- ✓ Latest Programmer News
- ✓ Latest Hardware News
- ✓ Latest SPACE Pacific Reports
- ✓ Cable TV Connection

Vol. 3 ♦ No. 27

Price Per Copy:
NZ\$8/A\$9/US\$5



Paraclipse[®]



When quality, strength, and accuracy are your main requirements, **Paraclipse** antennas are your first choice.

Only **Paraclipse** offers such variety; four distinctly different series:

- the Truss-Ribbed Classic,
- the Courier Deliverable Eclipse,
- the Stretch Formed Hydro,
- the Commercial Patriot.

Every **Paraclipse** model sets the industry standard in its class, worldwide.

HYDRO
SERIES

ECLIPSE
SERIES

CLASSIC
SERIES

Distributed in New Zealand by
Bay Satellite TV Ltd. PO Box 14050 Hastings
Tel: 64-6-878-9081 Fax: 64-6-878-5994

Paraclipse[®]
HIGH PERFORMANCE ANTENNAS

★ **MADE IN AMERICA**

Paraclipse Inc.
2271 29th Avenue East, Columbus, Nebraska USA 68601
Telephone: (402) 563-3625 FAX: (402) 564-2109

SatFACTS

MONTHLY

SatFACTS Monthly is published 12 times each year (on or about 15th of each month) by Far North Cablevision, Ltd. This publication is dedicated to the premise that as we enter the 21st century, ancient 20th century notions concerning borders and boundaries no longer define a person's horizon. In the air, all around you, are microwave signals carrying messages of entertainment, information and education. These messages are available to anyone willing to install the appropriate receiving equipment and, where applicable, pay a monthly or annual fee to receive the content of the messages in the privacy of their own home. Welcome to the 21st century - a world without borders, a world without boundaries.

Editor/Publisher
Robert B. Cooper
(ZL4AAA)
Office Manager
Gay V. Cooper
(ZL1GG)

Reaching SatFACTS
Tel: 64-9-406-0651
Fax: 64-9-406-1083
Mail: PO Box 330
Mangonui, Far North
New Zealand

Subscription Rates
Within NZ: NZ\$40 p/y
Australia: AV-COMM Pty
Ltd, PO Box 225,
Balgowlah NSW 2093
61-2-9949-7417
Elsewhere: US\$40 p/y

ERRATA
SatFACTS Copyright 1996
by Robert B. Cooper; any
form of copying is a
violation of our
international copyrights.
Advertising rate sheet
available upon request.

COOP'S COMMENT

I am not ashamed to admit my own lack of computer literacy. Close friends such as Mark Long chide me constantly for my failure to use e-mail or have in house access to Internet (in the latter case several loyal readers keep me amply supplied with Internet offerings). Gay and I have several sound reasons for avoiding these latest trends in technology but they shall remain private for now.

As a small town cable TV operator, I pride myself in offering a very high level of service to our subscribers. Presently this amounts to 39 channels of TV in a region of New Zealand

where most people have only 3 off-air channels (a few have 2 or just 1). When I began to learn the detail of the MediaNet Net On Air (Internet) service in August I started to work it into my conversations with cable subscribers. "Do you use Internet?" was my opening question. I usually manage to find myself inside a subscriber's home 10-15 times each week and conversations tend to be about the weather or someone asking why RAJ-TV has disappeared from channel 49. I estimate 25% of my cable subscribers have a PC and 100% of these bitch and moan about the local Telecom rate of NZ\$4.95 per hour for access. That 25% of my cable subs have a PC and use Internet was a shock to me since as recently as 1990 communities in my area still had a human being operated manual switchboard for their telephones ("Operator - what number do you wish please? Just a moment while I connect you.")

My informal survey of cable customers tells me that 100% of those equipped with a PC and already owning a modem for Internet will at least trial Net On Air via Deutsche Welle on our cable channel 24. I am shocked by this. Perhaps Gay and I need to rethink our own reasons for not being a part of Internet and e-mail if people who need help turning on their cable converters are already equipped for Internet. Somehow Internet has failed to "grab us" and I ponder why this is so. Perhaps because we are both licensed 'ham operators' and can hop on 20 meters and chat with somebody in London or Houston at will is a part of the reason. Perhaps because we have so much television choice in our home that we don't feel as isolated as others. Perhaps because we have in our lifetimes travelled far and wide and explored in "real time" hundreds of mini-worlds which others can only imagine or surf on Internet.

I am bothered by this strange intense interest in the new Net On Line offering. Are these people modern day explorers hunkered over a magic keyboard that transports them to distant points at will? If these cable subscribers have tried Internet via Telecom and find it wanting, will they likewise find Net On Air via Deutsche Welle wanting as well?

So we will be the first cable system in Asia and the Pacific to offer Net On Air service to our subscribers and will even install a terminal in our home. It's not quite e-mail to the world but for us it will be a significant step into the 21st century. "Internet? Connect me to Paris, please!"



November 15, 1996



In Volume 3 ♦ Number 27

LOOK What is Happening To Digital Receivers! -p.6
Horst Wieser Reports: Media Shock in Philippines -p.11
Internet Via Satellite -p.14

Departments

Programmer / Programming Update -p.2; Hardware / Equipment Update -p.4
SPACE Notes: Burning Copyright Questions -p.20 ;
The Cable Connection / Starting On a Shoe String -p.22;
SatFACTS Orbit Watch -p.24; MPEG-2 Tuning Parameters -p.26;
With The Observers -p. 29; At Sign Off (Net On Air Specifications) -p. 32
November Reporting Form -p.33; SPRSCS '97 Reg Form -p.34

-ON THE COVER-

German engineer Horst Wieser (Wieser Electronic, Nuernberg) at Dumaguete City, Philippines installing 2m dish for European Bouquet. As you read this, he is installing a similar system in Fergana, Uzbekistan for a German company building a tire plant there. Horst will speak at SPRSCS '97 on several topics including detailing the new MediaNet Net On Air internet service via satellite.

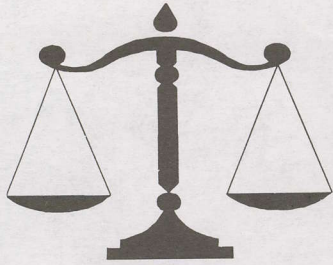

Council Orders Dish Removal

"My dish size is 3.6m and sitting just above my garage. Council asked me to place an application for the dish which I did. Then after receipt of the application, it was cancelled and I was told to remove it within 60 days. Can you help me solve this problem?"

N. Sivanthas

M.K.S. Enterprises, Berwick, Vic, Australia

SF asked the City of Casey for their reasons in denying this application. The City said, "(1)

The erection of the satellite dish will be detrimental to the amenity of the neighbourhood; (2) The erection of the satellite dish will detract from the visual environment and character of the neighbourhood; (3) The size and height of the dish is inappropriate in a residential area." Of interest, the Sivanthas antenna application was thoroughly studied by the Council Planning Committee which recommended approval of the application subject to some conditions. The full Council decided to ignore the Committee's recommendation and simply turned down the application. The subject of denied permission to grant dish applications throughout Australia and New Zealand remains hotly debated and timely. We welcome reports from others who are currently experiencing problems as well as those who are having no problems. Someplace in the middle of all of this may be a range of solutions.

Thailand Calling

"We are very interested as a SatFACTS subscriber to learn all we can about digital transmission systems; in particular, the symbol rate and FEC for various transponders / services."

Pitsanu Teerarajpong

Poly Communications Co., Ltd., Bangkok, Thailand

SF has published the latest digital tuning parameters since our July issue. This month's listing is expanded (p. 26) and is certain to grow with digital programming launches.

Indovision in SW Qld

"I am interested in the likely reception of HBO/ TNT/ ESPN/ Discovery channels from Palapa C2 in the far Southwest of Queensland. Here near Gympie, HBO and TNT are P5 while Discovery and ESPN have trouble staying locked and are only P2.

.LETTERS/ continued p. 4-

PROGRAMMER PROGRAMMING PROMOTION

UPDATE

NOVEMBER 15, 1996

Russian Express 6 at 80E began test transmissions October 30 although the first reports came only from European, Middle East observers (on the satellite's C-band northern coverage beams). Signals on 3820/IF1320 and 4025/IF1125 are "loud and clear." South Pacific observers should watch 3725/IF1425, 3775/IF1375, 3825/IF1325, 3875/IF1275, 4025/IF1125, 4025/IF1025 and of course the 36.7 dBw high power channel at 3675/IF1475.

RAJ-TV disappeared from 130E with little notice October 13, reappeared for few hours 14th and then off. Service has moved to 142.4E (northern zone beam, IF1420) and can not be watched with any but large dishes in NZ, very poorly in Australia. Reason? Read on ...

130E ex-Rimsat bird has been leased to Filipino Agila Satellite Corp at 153E for interim use until Agila launches their own C + Ku bird now scheduled for mid 1997. Russians were scheduled to move 130E to 153E weekend of October 28th but at least one Australian observer found it still at old position October 30th with Laos TV. Russians have many options for 130E; abandon it, sell location to one of several potential Asian suitors, place next Express bird there. Ex-Rimsat R41 from 130E meanwhile will end up in mid-1997 with +/- 1.5 degree inclination, nearing end of useful lifetime for dishes of 2m size that cannot track orbit. Where will go after Agila has own bird at 153E is also unknown, probably even by Russians. There are no announced Agila plans to fire-up old RAJ-TV powerhouse transponder (3675/IF1475) from 153E location.

EM TV on R42 (142.4E), facing increasingly inclined orbit of host satellite, believes it must reach decision "where to move" by 1st of January. With R42 now +/- 0.7 degrees (12' and larger dishes must track) and growing to +/- 1.15 degrees by July 1 (8' and larger dishes will need to track), station wants new home by end of June. Options: Filipino Agila or Mabuhay (153 and 144E respectively), Palapa C2M (113E), Intelsat 801 (174E) or 803 (180E). Most of the choices would eliminate coverage south of equator (CTD 9608, p. 16).

New Zealand terrestrial pay-TV service Sky Network did Ku-band digital testing on Intelsat 1177 at 11.463 GHz (Vt) during late October using Canadian C-band uplinked digital bouquet that was cross-strapped to Ku for transmission into (south) Pacific. Purpose of testing is to find proper bird (in running: Optus, PanAmSat and Intelsat) for April-June launch of 5 and then 10 programme channel MPEG-2 conditional access subscription service. Sky was delighted with 1177 Ku service levels finding 1.2m offset Ku dishes will be largest required for extremes of NZ (Chatham Islands). This (VII series) satellite has trio of "fully steerable" Ku spot beams that can be directed at any spot on earth visible from 177E with an eirp of 47 dBw (Optus, by comparison is 50+ dBw). More likely, Sky will go on newer VIII series bird at 174E or 180E if they really do go to satellite in 1997. Sky will need to make decision as to satellite and commitment for satellite very soon if they hope to make an April-June start date. Strange if true department: Sky claims they will distribute 'BBC World' via satellite as a part of their programme bouquet.

Catholic international TVcaster EWTN (Eternal World Television Network) is scheduled to begin transmissions using PowerVu MPEG bouquet (3901HZ/IF1259) December 8. Programming is 24 hours, in English, and should be 'sale opportunity' to Catholic church groups throughout Pacific.

RAI International video (no audio!) finally appeared on European bouquet November 4; the bouquet is now fully "flowered." (see update p. 29)

Paraclipse



Paraclipse
full range
down under!

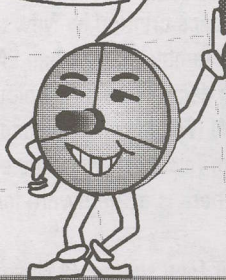

Paraclipse Antennas

- High efficiency perfect reception
- Precision hydroformed and mesh antennas provide years of trouble-free reception
- Exceptionally distortion-free C and Ku band reception, even from 2° spaced satellites
- One piece hydroformed reflectors
- Heavy-gauge aluminum antenna adds structural strength
- Protected with a baked-on powder-coat finish
- Self-aligning, three pole feedhorn support
- A heavy duty, pre-assembled, fully adjustable polar mount

Available from:

SKANDIA ELECTRONICS PTY. LTD.

Skandia

Head Office: 183 Burwood Road Hawthorn, Victoria, Australia 3122

Tel: (613) 9819 2466 Fax: (613) 9819 4281

NSW Office: 4/411 Church Street Nth Parramatta, NSW, Australia 2151

Tel: (612) 630 0888 Fax: (612) 630 8690

STARnet

-LETTERS / continued from p. 2-

Do you have other information from SatFACTS readers in this portion of Australia?"

Gary Salisbury

KAN SAT Satellite Television, Gunalda, Qld. In eastern Queensland all four of the B-MAC encoded services are typically P5 on dishes down to 2.4m. As you go west or south or east, HBO and TNT typically hold up far better than ESPN and Discovery. You don't include the dish size in use which leads to the obvious suggestion: When a signal is too weak, put in a bigger dish!

PowerVu In Tahiti

"We have installed over 100 TVRO antennas here in Tahiti and the surrounding islands of Polynesia and we are looking for a source of the Scientific-Atlanta PowerVu receiver so that we might access programming on PanAmSat. We are more than willing to pay for subscriptions to the programming."

Grant T. "Skip" Waldref, Jr.

STARCOM, Inc., Papeete, Tahiti

PowerVu is sold directly by the

Scientific-Atlanta office in Sydney (tel 61-2-452-3388 and fax 61-2-451-4432) at US\$1,295 plus US\$150 shipping per receiver.

However, you must have subscribed to a PowerVu service before they will sell you a receiver. So step one: Call programming representative Southstar in New Zealand at 64-9-426-0481 (fax 64-9-425-0581) and order Country Music TV at around US\$75 for one year. Southstar will then advise S-A Sydney that you subscribe to a service and S-A will then sell you a receiver. Once you have the receiver, you can then proceed to view both CMT and various (presently) free to air PowerVu services from PAS-2, and, subscribe to other conditional access services as available. Tahiti does not fit into most programmer "territories" so we cannot be certain which programmers will in fact authorise subscriptions there (although we checked and Southstar will sell you CMT).

NHK Going?

"In the August SatFACTS you listed 'The Services You Can Count On' (p. 14) and did not list NHK! As an avid fan of this service, does this mean that sometime in the future I will not be able to receive it? This would make me very unhappy as I have invested heaps of dollars on a system for this service!!!

Les Cole, Hamilton, New Zealand

We have no secret, inside information.

However, NHK is aggressive and surely plans to expand from their present single analogue channel to MPEG multi-channel. That could be a problem! We think their FTA status future "iffy."

HARDWARE EQUIPMENT PARTS

UPDATE

NOVEMBER 15, 1996

"Life is still hell here regarding IRDs," reports a spokesman for the European Bouquet (1 November). Frustration levels are rising as numerous would-be suppliers for MPEG-2 FTA capable IRDs appear with promises but alas no operating receivers in quantity. Primary problem remains Irdeto conditional access which all manufacturers would like to have included in their receivers but are finding impossible or at best very difficult to negotiate. See detailed update p. 6.

Scientific-Atlanta Sydney D9223 toll free service department number from New Zealand: 800-444-1521. Advice: Avoid "lunch time" in Sydney as nobody answers when they all clear out for chow!

EM TV SVA3 series decoder, manufactured to specs created by News Datacom (Murdoch controlled firm in UK), may lock up and scramble video when EM TV switches back to FTA format. Or, dish owner using decoder may find pictures scrambled when switching dish from EM TV to CNN (which is not encoded). Solution is to block line 12 in vertical blanking interval which falsely triggers the encryption circuit even when signal is in fact not encrypted. There is a "hardware (one chip simple circuit) mod" for this.

EM TV appears to have switched to a new off-air feed system (4 November) for getting their TV service to the uplink operated by PNG Telekom. The video noise level is improved but now the service has off-air ghosting from a not-so-hot antenna system. Someday, maybe, it will ALL come together!

Samsung is deeply involved in marketing of MPEG-2 digital receiver that is heading into the Indian market; so much so that they have for the moment lost interest in producing variations of this receiver for Pacific, Europe or anyplace else.

Hyundai Electronics is quietly showing off a pair of MPEG-2 products; model HSS-100 is designed for non-conditional access (i.e., FTA) applications while their DBS-100 uses the Irdeto conditional access system. Test units are on the way to distributors at this time.

Scientific-Atlanta has announced a pair of new PowerVu product: 9225 is described as an "economic alternative to the full-featured 9223" but lacks multiple audio channels, MPEG2 transport outputs, digital video and audio outputs and high-speed data capability. The 9234 is a Business Satellite receiver packaged as a set-top (stand alone) unit with a hand-held remote control and a 13Mbit data port for downloading batch files, catalogues and service manuals when the business TV network is not transmitting active video programming. More data on both from Paul Coxon at Sydney 61-2-9542-3388 (fax 61-2-9451-4432).

The Pace DSS-211 MPEG receiver heading for distribution through Star TV's new Indovision bouquet (SF#26, p. 6) is "essentially the same" as the News Corp receiver being distributed in South America for the recently launched Murdoch MPEG digital bouquet there. Designations such as 'GP' appearing after "DSS-211" relate to local variations in the receiver affecting things like the remodulated RF output format; not a major difference in the basic MPEG package design.

Taiwanese firm Rebar has leased 27MHz bandwidth C-band AsiaSat 2 space, plans MPEG distribution to cable TV firms of several programme channels before end of December.

Russian Express 12 will go to 155E, says Russian source. That could make life interesting for Filipino Agila at 153E!

Europeans attending SPRSCS '97, to speak and partake of the atmosphere, will include Jim Hodgetts of French TV5 Paris in addition to MediaNet hardware and software personnel to introduce "Internet via satellite" to Pacific region.

ADL[®]

BECAUSE PERFORMANCE IS ALWAYS YOUR FIRST PRIORITY

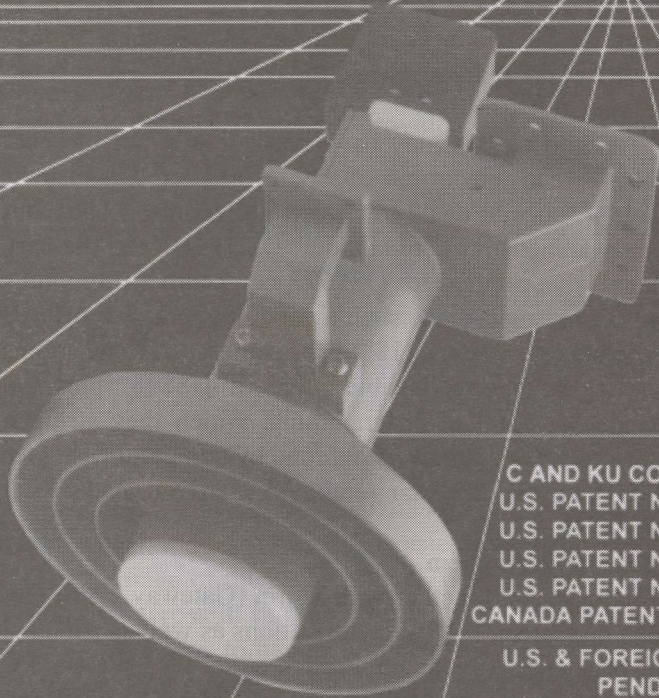

**RP3-CKU/ International
Adjustable Scalar Ring Feed
with Extended C Band**

C AND KU CO-BORSIGHT
U.S. PATENT NO. 4,903,037
U.S. PATENT NO. 5,066,958
U.S. PATENT NO. 5,107,274
U.S. PATENT NO. 5,255,003
CANADA PATENT NO. 1,328,922

U.S. & FOREIGN PATENTS
PENDING

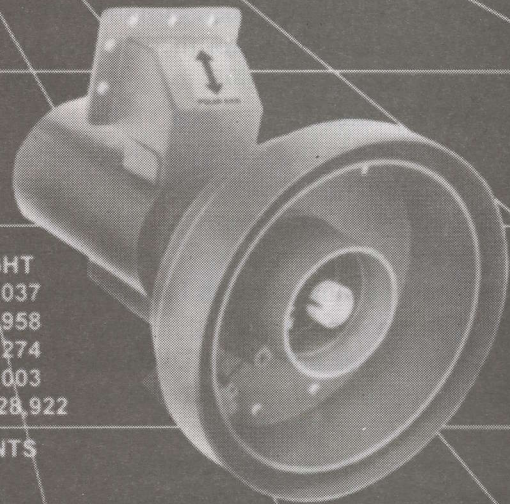

RPI-CKU Feed

ADL HYBRID MODING CIRCULAR POLARIZED INTELSAT FEEDS WITH EXCLUSIVE T.I. REJECTION



RP1-CP400

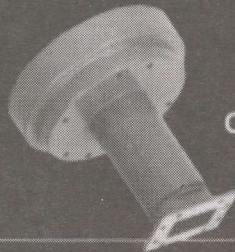

CP-300



CPOR-100

- C BAND LINEAR & CIRCULAR • C/KU LINEAR & CIRCULAR • KU 12 GHz FEEDS
- INTELSAT 4 GHz CIRCULAR • ARABSAT S BAND FEEDS
- OPTIONAL: CO-BORSIGHT S BAND

2216 AGATE COURT, UNIT B, SIMI VALLEY, CALIFORNIA 93065 • (805) 526-5249 • FAX (805) 584-0634

LOOK - WHAT THEY ARE DOING WITH MPEG RECEIVERS - NOW!

The first MPEG (1.5, not DVB compliant MPEG-2) digital TV service launched in America in June 1995. Satellite manufacturer Hughes in partnership with RCA/Thomson Consumer Electronics created a system which today delivers 175 TV programme channels to several million North American homes on Ku-band using 18" / 46cm dishes. For the initial one million receiver systems, Thomson had the exclusive right to sell equipment. As sales reached the magic million mark Sony followed by a host of other firms were allowed into the field. Pricing for the first 1.5 million or so units stayed around US\$695 for a complete home system (install it yourself).

Then along came competition to the Hughes (DSS) system. First there was a lower power / bigger dish antenna (77 to 100 cm) service called PrimeStar. Followed by a 40-60 cm dish service called 'DISH' and most recently along came a fourth Ku-DTH programmer calling itself AlphaStar.

Home system prices hotted up; DISH started at \$595, then dropped to \$300 and more recently to \$200. These are all US dollars to translate to your own currency. 'DISH', which is backed by C-band TVRO pioneer Echostar, took the approach that as long as they sold both the receivers and the programming, they would be better off to drop the price of the receivers to eliminate buyer resistance. Why? Because if twice as many people purchased systems and subscribed to programming for a system that cost \$300 as for one that cost \$600, they would gain the people as paying subscribers and therefore realise more money more quickly by getting them as subscribers sooner - not later. Kodak in the 1930s figured this out with their Box Browning camera: "Give the camera away" because people who owned cameras would buy film. It was better to make money on the film and break even, even lose money on the tool (camera) that used the film. Gillette, the safety razor people, built a world-wide empire for men's hand razors with the same philosophy.

By mid-July, under intense competitive pressures, a complete "Take it home and install it today" Ku-band DTH system was selling in America for US\$200. There was only one condition: When you purchased a \$200 system, you also had to purchase a year's worth of subscription programming in advance for an additional \$300. But hey - you couldn't use the system for any purpose without subscribing to a programming package

so this was hardly an impediment to a sale. And besides, dozens of financing plans were available which spread the \$500 (total cost of hardware and programming) charges over a year payoff anyhow. For \$500 you got as many as 40 channels of TV and 30 channels of CD quality radio and you owned the equipment. Try that on, Galaxy, in Australia!

As wild as this may have been, it was not the end. That's when electronic discount retailer Brandsmart made a "special deal" to help RCA/Thomson clear out their warehouses of "old model" DSS receivers; the very models that retailed for US\$695 as recently as 8 months ago. Brandsmart made such a good buy that they offered the complete system (18" dish, cables, IRD and more) for the quite unbelievable price of US\$48 (plus the mandatory \$300 in programming, which they stripped down to \$299). Not to be outdone by competitor Hughes and Thomson, Echostar retaliated. Can you guess what they did?

Free 'DISH' system.

Echostar got together with a firm (Gateway 2000) that sells big-screen PC/TV combinations as well as personal PC packages. Anyone purchasing either the Gateway PC + TV or the PC package is being given a 'DISH' system free of charge. Well, almost free of charge; the buyer still has to fork out \$300 for a year's subscription to 40 TV channels and 30 CD audio channels (1).

The DigiSkan SK888

Virtually everything we know about MPEG digital TV receivers and their pricing here in the Pacific/Asia originates from our fleeting dealings with Scientific-Atlanta (D9222 and then D9223), Pace (DGT-400, DVR-500) and Panasat (IRD-520). On the other hand, the undisputed volume producer in this field is Thomson Consumer Electronics, primarily because of their head start with the US 'DSS' project in 1994. We are about to learn a great deal more about Thomson and the way they design receivers which those 'Crazy

1/ SatFACTS for October reported (p. 28) that Australian Galaxy was offering their DGT-400 receiver 'for sale' at A\$619 in Western Australia. There was, of course, a hitch; the buyer also had to purchase a year's worth of programming for an additional A\$600. Compare A\$1,219 for the Galaxy package of channels against the US price of (US)\$348 which gets you the Thomson built system plus 40 channels of TV and 30 channels of CD quality radio for one year. US\$348 as of 1 November was A\$465.

DigiSkán

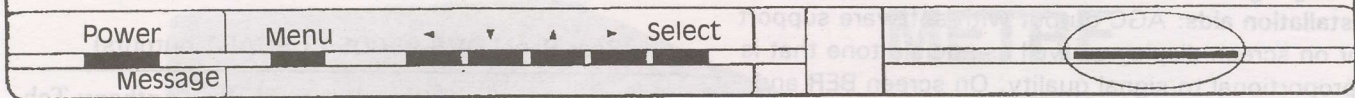

DigiSkán SK888 front panel (line drawing); Smartcard insert slot is far right, centre.

Americans' are now selling for \$48 (complete with LNB, dish and cables). Here comes the DigiSkán SK888.

The DigiSkán SK888 came to the Pacific via a circuitous route. When it arrived, it was unnamed (2) and the return address on the box said it had been shipped from a small Middle Eastern country. The shipper of the trial receiver, "provided for testing," had the forethought to build into the memory all of the European Bouquet MPEG-2 tuning parameters. The original instructions simply said, "Take it out of the box, connect a suitable C-band antenna pointed at AsiaSat 2, plug-in and turn on." It doesn't get much simpler than that.

As Leon Senior at Skandia Electronics (Melbourne) relates, "I figured nobody was less technical than I. So I insisted on being the guinea pig when we unpacked it. I followed the one sentence of instructions, poked 'on' followed by 'European Bouquet' and there was *Deutsche Welle*." And, it doesn't get much easier than that.

The heritage of the receiver has Thomson technology written all across it. In other words, with Thomson now well on their way to having shipped two million MPEG digital receivers, well ahead of all of the rest, they have learned quite a little about (1) eliminating confusing user instructions, (2) making the system 'poke and go' for simplistic non-technical type use, and most important of all, (3) how to build a reliable receiver that is cheap to reproduce. A firm that is able to empty their warehouse of "older style receivers," complete with LNB, dish and cables for less than US\$48 each, certainly knows a few things about salesmanship that the likes of Scientific-Atlanta have not yet discovered.

The SK888 is (we shudder at this statement but it is in quote marks) scheduled to "arrive in Melbourne in quantity sometime before the end of November (3)."

2/ Anecdote time. '888' is considered "great good luck" by the Chinese. The fellow who selected the model number for this receiver is keen on Oriental "good luck" symbols; a story we may relate at a later date (depending upon how the SK888 turns out!).

3/ Skandia Electronics, Melbourne: Tel 61-3-9819-2466; Fax 61-3-9819-4281.

4/ We hesitate to publish the complete list until SatFACTS has received for test an advance unit; this remains a 'tricky' business and there is no point in setting off alarms all over Asia and the Pacific.

The SK888 was, after test in Melbourne, immediately modified on request by Skandia to include a number of other "built-into-memory" free to air MPEG transponder parameters in addition to the European Bouquet (4). The important point here is that the system installer (whether dealer or end user) need only do what Leon Senior did - follow the one sentence instructions and select the programme channel you wish using the remote control. FEC "search" is reported to be "built-in" and if you don't have to pound in all of those annoying FEC/Symbol rate/RF-IF entries because the factory has done it for you - so much the better.

What The Manual Claims

"The SK888 family of SMS/ADB Digital satellite receivers has been designed for low cost consumer receiver applications compatible with several satellite receiver broadcast systems world-wide. The receiver utilises the MPEG-2 audio/video compression scheme and is DVB compatible. However, in addition, the 100% software based TRANSPORT function allows application in non-DVB environments such as the American DirecTV (DSS) service.

"Similarly, the SK888 can accommodate a range of Conditional Access mechanisms. The four most popular systems presently implemented are NDC, Irdeto, Cryptoworks and Nagravision. The SK888 has been designed around the SGS-Thomson chip-set, led by the company's third generation MPEG products family, and used successfully by all of the world leaders in digital DBS transmissions.

"The base model of the receiver, as defined in this specification, includes a single input tuner, stereo sound, infrared remote control, user friendly software which includes an Electronic Programme Guide with a 'point and click' Navigation system, and front panel access to a renewable security system (Smart Card)."

All of the MPEG functional digital receivers available before the SK888 have been bred in the tradition of professional grade single-use receivers. That is, not have the built-in conveniences which channel hopping, bird changing DTH viewers now routinely expect and demand in analogue receivers. The SK888 appears to have been designed to allow someone familiar with "point and shoot" handheld remote analogue DTH systems to move easily to the same features in a digital receiver. At this point in digital development, no other

-SK888 Receiver Feature Rundown-

Front Panel Display: Power on/standby, error LED.

Operational menus: Primary and secondary languages on screen displayed simultaneously.

Installation aids: AGC output with software support for on screen display as well as audible tone that is proportional to signal quality. On screen BER and signal level displays. "Installer" level receiver self-diagnostic menus.

Electronic Programme Guide: On screen (must be supported by bouquet programmer) with point and click programme selection through remote. Includes radio and radio/TV choices.

Video outputs: S-Video (4-pin) Y/C and RCA phono (composite); SCART available as option.

Audio outputs: Monaural, dual-mono, stereo in RCA phono jacks. User selection of audio language channel, closed captioning.

Input frequency range: 950-2050 MHz IF

Input Tuner: Sharp (Japanese)

Input levels recommended: (-) 30 to 65 dBm

AFC Range: +/- 5 MHz capture range

Synthesiser Steps: 125 kHz

LNB Tone Switching: 22 kHz (optional)

LNB Powering: +13, +18 VDC

UHF Remodulator: PAL-G E21 to E69 set with on screen menu.

Copy Protection: Macrovision Anti-Copy (optional)

Note: Optional features are selected by the "brand buyer" of the basic model described here.

receiver offers these features (see Feature Rundown, this page).

What remains of course is to see one "in the flesh," to try it on some of the more "unusual" digital service channels (such as Associated Press TV on AsiaSat 2), test its reliability and ease of use. Perhaps by the next issue of SatFACTS we will have that opportunity.

MEANWHILE - At Nokia

While the Thomson-chipped SK888 was making its way to the Pacific and Asia, the long promised and much anticipated DVB 9500 S by Nokia was making its first appearance. The first unit available for test by SatFACTS was scheduled to arrive just as this issue was being sent to the printer; a report next month! The early 'sources' were spotted at two European

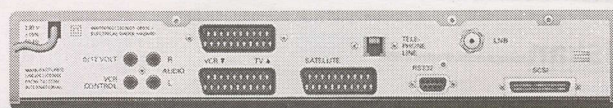

Rear Panel DVB 9500S (3 SCART outputs)

locations by several SF readers (including Anthony Teh in Western Australia) while browsing through Internet. Our thanks to the many who sent us sourcing information.

There could be two software versions of the 9500 S and we caution anyone contemplating a purchase from Europe to be certain the unit has been 'softwared' for our Pacific services. We'll explain further with the full review.

We looked at the advance literature announcement for this receiver in SF October (p. 16). The key phrasing in the latest literature sheet reads, "Fully DVB Compliant." The newest sheets also say:

- 1) Tuner covers 950-2150 MHz
- 2) The PCMCIA and smart card capability are built-in.

European interest in (DVB Compliant) MPEG-2 transmissions has exploded as dozens of new bouquet packages have suddenly become available or plan operation shortly. Nothing will fire up the production facilities of firms such as Nokia faster than a backyard demand for their products.

THE Pace DVS-211

Another new product showing up in very small quantities is the Pace DVS-211 (GP). This receiver was originally intended to be utilised for the STAR TV Southeast Asia MPEG bouquet which we detailed in SF for October (p. 6). The DVS-211 appears to be conditional access built around a smart card (they call it a "viewing card") with a "unique address." The receiver has some interesting new-for-MPEG wrinkles:

- 1) VHF/UHF aerial loop through to facilitate switching between terrestrial TV and satellite
- 2) Mechanical polariser connections (for power, pulse and ground) as you are familiar with in analogue receivers
- 3) Phono connectors for video and audio (no sign of a SCART plug on this one!)
- 4) 12-14 and 17 - 20 volt polarisation switching for LNB selection
- 5) LNB 22 kHz tone switching

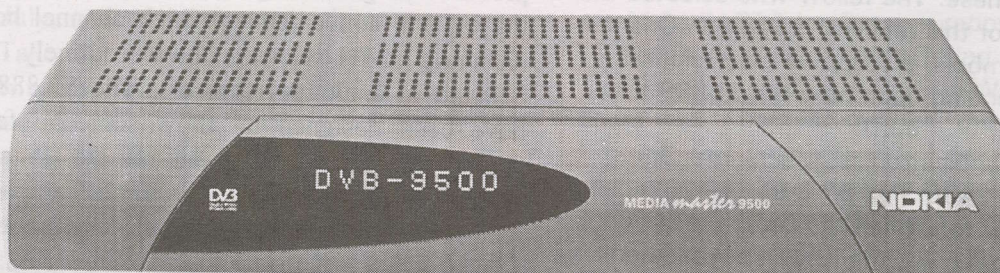

PANORAMIC SATELLITE METRE

MC10-SAT

AU\$1599 (TAX-EX)

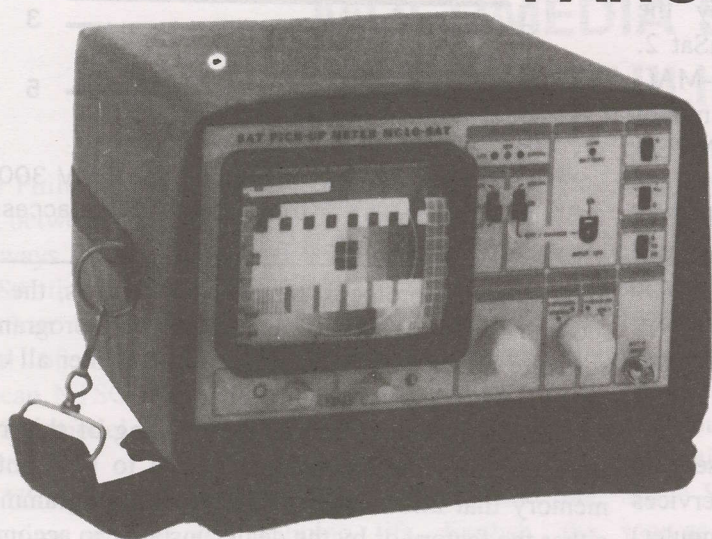

A PERIFELEC
PRODUCT

- SATELLITE POINTER AND FIELD INDICATOR WITH RECEPTION ON 14cm (5.5") SCREEN
- FREQUENCIES FROM 950 TO 2150 MHz
- DISPLAY OF FULL-BAND AND EXPANDED SPECTRUMS ANALYSER
- DISPLAY OF PICTURE OF SELECTED CHANNEL
- POSITIVE (Ku Band) AND NEGATIVE (C Band) VIDEO DEMODULATION
- MEASUREMENT OF SIGNAL RECEPTION STRENGTH BY WHITE BAR SUPERIMPOSED ON THE PICTURE AND PROPORTIONAL IN LENGTH TO THE SIGNAL IN STRENGTH
- RANGE OF MEASUREMENT OF SIGNAL STRENGTH BY WHITE BAR SUPERIMPOSED ON THE PICTURE AND PROPORTIONAL IN LENGTH TO THE SIGNAL STRENGTH
- RANGE OF MEASUREMENT OF SIGNAL STRENGTH FROM 50 TO 90 dB μ V
- POWER SUPPLY TO LNB IN 14 OR 18 VOLTS AND 22 KHz
- BATTERY LIFE : ABOUT 1 HOUR
- WEIGHT : 5.1Kg

THE MC10-SAT SATELLITE FIELD STRENGTH METER IS NOW CONSIDERED AS THE ESSENTIAL TOOL FOR ADJUSTING SATELLITE RECEPTION DISHES. THE VISUALISATION OF THE SPECTRUM AND THE PICTURE ALLOWS THE CARRYING OUT OF ALL THE NECESSARY ADJUSTMENTS WITH THIS ONE INSTRUMENT.

FREQUENCY RANGE : from 950 to 2150 MHz
TUNING: Multiturn potentiometer
INPUT IMPEDANCE : 75 Ohms
INPUT CONNECTOR : F-TYPE
INPUT ATTENUATOR : 0.10 & 20 dB USING 3 POSITION SWITCH

SIGNAL STRENGTH :

- **INDICATION :** by a white bar superimposed on the picture, its length being proportional to the strength of the received signal, and also by audio indicator
- **READING :** on the scale from 0 to 70 dB μ V
- **MEASUREMENT RANGE :** from 50 to 90 dB μ V
- LNB POWER SUPPLY :** 14 or 18 V and 22 KHz by switch

DISPLAY ON 5.5" CATHODE TUBE

- **SPECTRUM :**
- Full band spectrum (FROM 950 TO 2150 MHz)

- Expanded Spectrum with visualisation of the counter-polarisations

- PICTURE :

- positive video polarity (Ku Band) or negative video polarity (C Band)
- Picture of selected channel only
- Picture of selected channel with signal strength indication

POWER SUPPLY : 12V, 3 AH battery
CONSUMPTION : 1.2 A (without LNB)
BATTERY LIFE : about 1 hour
CHARGING TIME : about 4 hours
DIMENSIONS : 240 x 140 x 270mm
WEIGHT : 5.1Kg

ACCESSORIES INCLUDED : Measurement cord, AC mains adaptor, charging lead for car cigar-lighter, case.

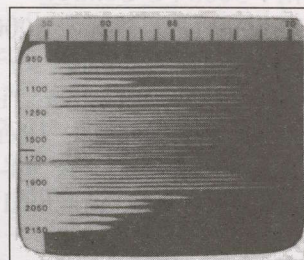

FULL BAND SPECTRUM

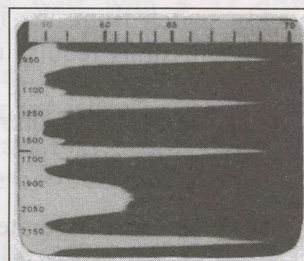

EXPANDED SPECTRUM



DEMODULATED PICTURE



PICTURE + MEASUREMENT



TEL 61-2-584 1233 FAX 61-2-584 1452

99-105 BOUNDARY ROAD, PEAKHURST NSW 2210 AUSTRALIA

- 6) IF bandwidth of 36 MHz
- 7) Receiver tuning range 950 - 2050 MHz

In addition to this receiver being selected for the STAR bouquet, it is also to be utilised by the (Australian) Sky (horse racing) channel on AsiaSat 2. This service is scheduled to convert from B-MAC analogue encryption to MPEG sometime this month (dependent upon installation of the uplink MPEG transmission equipment).

Jakarta sources continue to advertise this receiver in the A\$500-600 region but the price is not very important if the supply lines are empty. One source at STAR advised SF "We have received fewer than 50 of these receivers (late October) at this time and they are not available for users."

DMV 3000 PC Control

The NTL/DMV 3000 receiver, widely used by broadcasters and cable for receiving the MPEG services from STAR and others, is capable of PC (computer) control. A manual (Remote Control Protocol) is available (DMV: fax 44-1703-498102) which details interfacing and practical uses for the serious PC enthusiast.

The concept is that by using the PC the user can quickly switch from one input source to another when the transmissions require different receiver settings (IF input, FEC, symbol rate and perhaps PID settings). Normal operation requires re-entry of all of the parameters through the manually operated remote control.

The software operates in MS Windows through receiver to PC connections show here. The control software is set up as:

- Baud rate - 19200
- Data bits - 8
- Stop bits - 1
- Parity - none
- Flow control - XON/XOFF

The PC COMM port is connected to the IRDSK1 RS232 data port with the cable connections shown.

✓ Press H and the following menu should appear:

```

NTL MPEG-2 module
Version (3.2)
MC68K monitor
M = Memory examine and change
F = Fill RAM with data string
L = Load Motorola format
G = Go to new program
H = Display monitor commands
R = Display register contents
P = Program FLASH
T = Test FLASH

```

Six pages of DMV supplied user instructions follow. The point in this exercise is simply this: In an environment where a receiver is to be utilised for two or

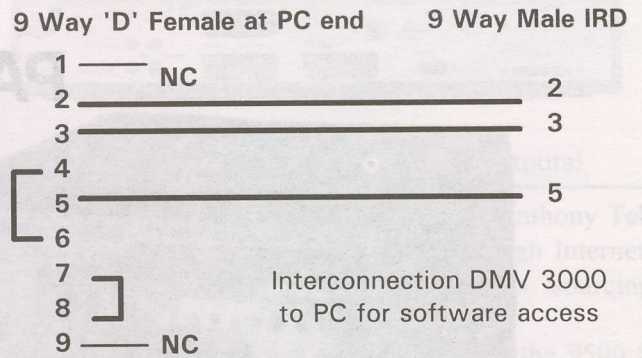

more differing protocol transmission sources, the 3000 receiver can be controlled from pre-programmed software rather than having to manually enter all of the parameters with each bouquet change.

The SK888 described at the opening of this report appears (from the literature at least) to have internal memory that allows the receiver to be programmed at either the factory or by the dealer/installer to accomplish the same result without having to dedicate or connect a PC to the receiver. For digital IRDs to be friendly enough at the consumer level to be attractive to non technical users this sort of design approach is mandatory.

Scientific-Atlanta D9223 Update

Without fanfare Scientific-Atlanta appears to have upgraded the software contained in their D9223 MPEG IRDs. According to sources at the Sydney S-A office, the presently in-stock receivers contain software which allows users to access MPEG-2 ("DVB Compliant") transmissions such as NBC Asia (PAS-2). This is essentially the same software routine which SF reported in our September issue (p. 20) as being "under test" by satellite enthusiast Robin Colquhoun in New Zealand.

Colquhoun's receiver has been tested using some AsiaSat 2 sources as well, including the APTV service (IF 1351 Hz). Unfortunately for "normal" users, the receiver requires extensive keypad entries to change either receiving format (from PowerVu to MPEG-2) and/or transmission parameters. As with the DMV 3000 PC software control reported above, Colquhoun and others in Korea report the RS232 rear apron port can be connected via an appropriate cable to allow the receiver to be more quickly changed from service to service through software memory external to the D9223. However, as noted with respect to the DMV 3000, only a small handful of commercial installations will go to the trouble and expense to implement a PC connection and to learn the software routines necessary to allow the receiver to change input parameters without re-entering complex instructions through the keyboard.

As important as multiple format access may be for the first generation of consumer oriented DVB Compliant receivers, perhaps of equal importance will be the receiver ability to memorise all of these complicated instructions. To be consumer friendly, a receiver should allow simple one or two button point and shoot.

MULTIMEDIA SHOCK FOR THE PHILIPPINES

The Philippines is an interesting study in television caught between two worlds; North America and Asia. In many ways Filipino television is more in the model of the USA than Asia yet the populace is clearly more Asian than American. The Philippines is one of only a handful of Asian countries to have adopted the American NTSC television standard (1) but its use of the USA model goes far beyond a set of technical specifications.

The US military presence has played a significant role in shaping modern day Filipino life. English, the language, is the "second language" of the country although there are also significant traces of the country's period under Spanish rule which terminated at the very end of the last century. One of the most enduring relics of Spanish colonial times is the heavily Catholic population, a fact not overlooked when international Catholic telecaster Eternal Word Television Network (EWTN) elected to expand into the Pacific (2).

During the coming 12 months the presence of the Philippines within the Asia - Pacific community will become undeniable as two new, competitive to one another national Filipino satellite systems come into operation. Agila is a one satellite in flight, one built and ready to launch on ground spare system, each with twenty-six C-band and 12 Ku-band transponders. The latest schedule for Agila to launch places it near mid-year for operation from 153E. The C-band coverage has not been published but is reported to include the Philippines, Southeast Asia and Hawaii. Agila

negotiated an agreement to rent/lease Rimsat 41 from the Russian owners in September and this satellite, cleared of the existing Indian and Laos telecasters, should be operational (after having been moved from 130E) at 153E as you read this report. This Rimsat is to be a bridge from this location until Agila 1 is actually operational.

Mabuhay Philippines Satellite Corporation is Agila's competition. They have a C + Ku band satellite built by Space Systems/Loral scheduled for launch to 144E as soon as February (1997). This satellite will operate from 3.6 to 4.2 GHz giving an extra 100 MHz of bandwidth below the normal 3.7 GHz cut-off of older satellite designs; 30 total transponders using linear polarisation. At Ku, the bird will utilise 12.2 to 12.7 GHz with 24 linear polarised transponders. The C-band coverage focuses from the Philippines west with a 37 dBw contour taking in most of the Southeastern Asia peninsula region. On Ku-band, a 54 dBw footprint covers all of the major Filipino islands and extends northward over much of China. Like Agila, Mabuhay also includes a spotbeam pattern to Hawaii (35 dBw) on at least some transponders.

The Philippines, similar to Indonesia, is scattered across thousands of islands which makes normal terrestrial linking difficult and expensive. There are four competitive commercial TV networks plus a government run network and each wants to cover as many of the scattered population centres as possible. Additionally, there remain thousands of villages without terrestrial telephone line links. Satellite intra-linking not only



Dumaguete City, Island Negros, Philippines at 9.5N and 123E; 2m dish focused on AsiaSat 2 for European Bouquet reception at Grabner Electronic

- 1/ Japan, (South) Korea and Taiwan are the other 3 major countries using NTSC in Asia
- 2/ Spain ruled the Philippines until 1899 when it lost it at cessation of the Spanish-American war. EWTN is scheduled to begin Pacific Rim service using California uplinked PowerVu format on December 8th. As a result of Spanish rule in the Philippines, the country is "more Catholic" than any other in Asia or the Pacific.
- 3/ This report compiled from material submitted by Horst Wieser of Wieser Electronic, Nuernberg, Germany (see front cover photo, this issue). Wieser will lecture during SPRSCS '97 on both MPEG-2 digital receiver systems and the use of the MediaNet (Internet) service via satellite (see p. 14, this issue).

2	RJ TV 29	19	STAR SPORTS	35	RCTI
3	PTV	20	CNN	37	CCTV1
4	GMA	21	ABN	38	CCTV2
5	RPN	22	CNBC	39	STAR TV
6	IBC	23	CHANNEL V		CHINESE CHANNEL
7	ABS-CBN	24	MTV	40	CETV
8	CITYNET 27	25	BARKER CHANNEL	41	CETV 1
9	HBO	26	COMMUNITY CHANNEL 1	42	CETV 2
10	STAR TV CINEMA	27	COMMUNITY CHANNEL 2	43	CETV SHANDONG
11	STAR MOVIES	28	COMMUNITY CHANNEL 3	44	CTN
12	VIVA CINEMA	29	SUN ENGLISH MOVIES	45	RTP
13	TNT CARTOON NETWORK	30	SUN TAGALOG MOVIES	46	RTM 1
14	DISCOVERY CHANNEL	31	VIDEOKE CHANNEL	47	SCTV
15	HOLLYWOOD CHANNEL	32	ATVI	48	STM
16	STAR PLUS	33	NHK	49	CANAL FRANCE
17	NBC	34	ANTEVE	50	MONGOLIA TV
18	ESPN	35	TPI	51	OCTV

Sun Cable Office, Ang Boulevard Bldg., Rizal Avenue, Dumaguete City
Tel. Nos. 225-7691/225-7692

Channel line-up subject to change without prior notice.

Dumaguete's Sun Cable 54 channel programme listing - "Cultural media shock!" reports Wieser

makes excellent economic sense, it in many cases is the only viable system of interconnection.

The Philippines is a production centre for many electronic firms headquartered elsewhere in Asia as well as Europe and North America. The labour market is sizeable and wages by world standards low averaging in 1995 US\$5.80 daily. German headquartered firm Grabner Electronic, Nuernberg is one such firm. When the European Bouquet became available from AsiaSat 2 it was understandable that the firm's owner would like to have Deutsche Welle reception at Dumaguete City. Fellow German Horst Wieser of Wieser Electronic was equally anxious to visit the Philippines and an agreement ensued; Wieser would manage the installation of a 2m (6 segment) dish sourced from the USA along with a NTL DMV model 3000 receiver. The EBB reception is about the only channels the Grabners did not already have as subscribers to the local 54 channel cable system (see channel list, above).

Cable in the Philippines is extremely robust, perhaps fed by the easy access to a tremendous selection of television programming from satellites that not only serve the South Pacific but those that don't come south of the equator as well. The Sun Cable system illustrated here is in a town of 120,000 people and offers 54 channels of TV from such diverse selections as Mongolia TV (channel 50, via AsiaSat 2) and five movie channels (HBO, Star TV Cinema, Star Movies, VIVA Cinema and Hollywood Channel).

With all of this for approximately US\$20 per month. It might be difficult to build much of a DTH business there given this competition!

The next wave of Filipino television expansion will be driven by the ability of Agila and Mabuhay to export Filipino TV product throughout Asia and North America. That some of this will also end up in the Pacific over the next 12 - 24 months in a format usable by DTH and cable systems here is very likely. There are probably many Filipino channels in your TV future!

Dear Smart Viewer,

How would you like to watch movies, news, and sports programming using fiber optic technology that provides the clearest reception 24 hours a day?

As a resident of Dumaguete, you are invited to subscribe to Sun Cable. Simply call 225-7691 or 225-7692 or fill out and send the attached coupon to the Sun Cable office. Act now and pay only P499 and you get one month free subscription. Offer is good for the first 1000 respondents!

As with all the other Sun Cable operations nationwide, viewers in Dumaguete will enjoy a state-of-the-art system using fiber optic technology to provide crystal-clear reception. What's more, we have installed back up power to guarantee you continuous viewing pleasure.

If you have any questions or if you need any assistance, just call us. Our people are highly-trained professionals ready to provide quality service all the time.

So, if you're ready for TV entertainment like never before in Dumaguete, subscribe to Sun Cable now!

Sincerely,

MR. PANCHITO GARCIA
General Manager
Sun Cable, Dumaguete

P.S.

Subscribe to Sun Cable now! Pay only P 499 and you get one month free subscription. Offer is good for the first 1000 respondents!

June 1996



SUN CABLE IS NOW SHINING BRIGHTLY IN DUMAGUETE.

One of the hottest and brightest cable TV networks in the country is now in Dumaguete! Sun Cable. Enjoy the best foreign programs, up-to-the-minute news and the latest sports matches that cable TV provides -- at affordable rates. Plus, with our world-class technology, you're sure to experience unparalleled entertainment 24 hours a day.

FIBER OPTIC TECHNOLOGY FOR CLEAREST AUDIO/VIDEO RECEPTION.

Sun Cable is backed up by a strategic alliance with United International Holdings, one of the largest cable TV operators outside the U.S. Expert advice and the use of fiber optic technology assure you of a reliable system that sends the clearest signals. Our technological edge will also provide for future innovative services like interactive TV, data communication and Internet access. It's a "future-proof" system. And to ensure you continuous viewing pleasure, back-up power is available in case of power interruptions or fluctuations.

MORE CHANNELS. MORE VARIETY. MORE ENTERTAINMENT.

Enjoy top-notch international movies from HBO, Star Movies, the Hollywood Channel and Star TV entertainment channels. Keep up with the news from CNN, ABN, and CNBC. Watch the sports coverage of ESPN and Prime Sports. Explore your world through the Discovery Channel. Sun Cable gives you all these and a whole lot more, 24 hours a day! Sun Cable also provides coverage of news and events within and around your area through its own Community Channel.



A SHINING EXAMPLE IN CUSTOMER SERVICE.

Sun Cable not only guarantees exceptional and continuous cable TV viewing, we provide excellent customer service as well -- all the time. Anytime you need assistance, simply call our hot line at telephone numbers 225-7691 or 225-7692. Our highly trained personnel will be glad to assist you.

**1996
EIGHTH EDITION**
covering Australia, New Zealand
and the South Pacific

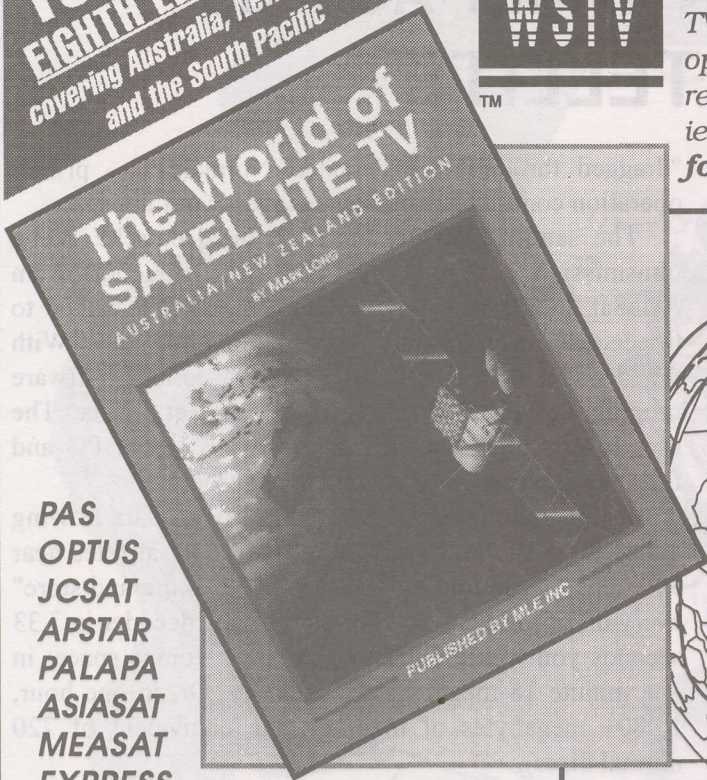

**PAS
OPTUS
JCSAT
APSTAR
PALAPA
ASIASAT
MEASAT
EXPRESS
INTELSAT
THAICOM
STATSIONAR, ETC...**

Introducing a Newly Revised & Expanded Edition of the world's best selling satellite TV technical handbook on buying, installing, operating and maintaining home satellite TV receiving systems. More than 200,000 copies sold worldwide. **Published especially for Australia & New Zealand !**

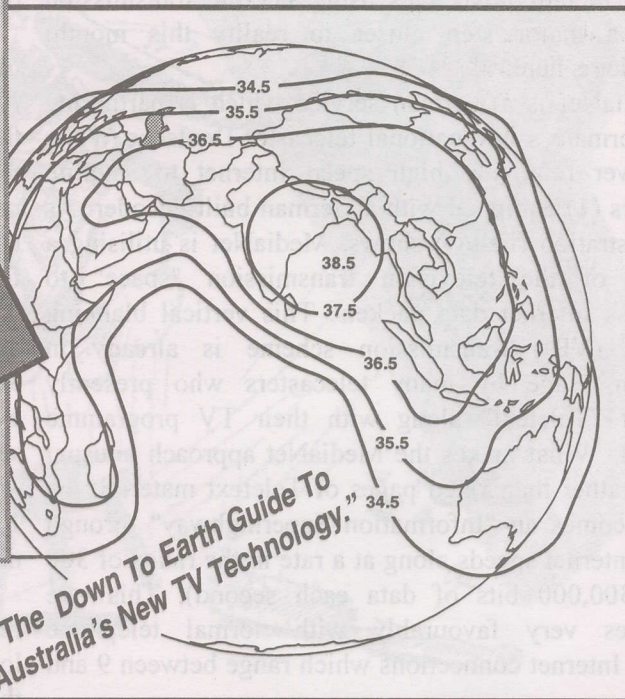

Featuring all-new descriptions of the existing and future domestic, regional, and international satellites serving Australia, New Zealand and the South Pacific. **The World of Satellite TV (WSTV)** presents the very latest direct-to-home (DTH) satellite TV receivers and IRDs, feedhorns, antennas and LNBS, as well as presentations covering signal encryption and MPEG-2 digital video compression. Also featured are step-by-step instructions on how to install, operate, maintain and repair DTH systems—including the use of satellite test equipment—and overviews of MMDS and SMATV distribution systems. Jam packed with more than 70 photos, 75 technical charts and graphs, 50 new satellite coverage maps, and a 17-page section covering the available satellite TV program services. **The World of Satellite TV** includes 216 pages perfect bound in a 247x186mm format, printed without advertising!

Ordering Information: WSTV—Australian & New Zealand Edition is now available for A\$29.90 plus A\$5. for Express Post to anywhere in Australia, or A\$15. for Air Mail dispatch to New Zealand and the South Pacific. We accept Bankcard/Visa/Mastercard.



**AUSTRALIAN &
NEW ZEALAND
EDITION**

Peter C. Lacey Services Pty. Ltd.
80 Dandenong Rd., Frankston, VIC 3199 AUSTRALIA
Tel: (03) 9783 2388 Fax: +61 3 9783 5767
e-mail: placey@netlink.com.au

Name Address

City Postcode Phone

Bc/Visa/Mc no. Expires/...../..... Signed

100 - 400 kbps INTERNET ACCESS VIA SATELLITE

The promise of delivering high speed data such as Internet to individual sites using satellite transmission moves a major step closer to reality this month: MediaNet is here.

MediaNet is a German service which is partnering with Germany's international telecaster Deutsche Welle to deliver relatively high speed Internet to satellite receivers (1) equipped with a German built decoder. As the illustration (below) shows, MediaNet is utilising a portion of the television transmission "space" to compress Internet data packets. This vertical blanking interval (VBI) transmission scheme is already in common usage by many telecasters who presently transmit "Teletext" along with their TV programme material. What makes the MediaNet approach unusual is that rather than fixed pages of Teletext material, the VBI becomes an "Information Superhighway" through which Internet speeds along at a rate in the range of 300 kbps (300,000 bits of data each second). This rate compares very favourably with normal telephone modem Internet connections which range between 9 and 29 kbps.

MediaNet is making the decoder box available through a number of German sources; this will translate to Australian / New Zealand / Pacific sources by the end of the year. The German price for the decoder is in the range of DM125 which is before shipping, import duties and normal costs of distribution.

The decoder is installed between the PC (computer) and its printer. Normally the printer plugs directly into the PC but with the MediaNet decoder added, the decoder plugs into the printer port of the PC and the printer plugs into the decoder. In operation, the printer is

"dragged through" the decoder. Normal PC - printer operation continues when the decoder is not in use.

The satellite IRD is tuned to the Deutsche Welle transmission channel (1 on European Bouquet) from AsiaSat 2. The video output from the IRD is linked to the decoder using normal RCA phono video lines. With the decoder is a Windows 3.1 / 95 format software program designed to manage the MediaNet service. The user inserts the disc with the software in the PC and follows on screen prompts to use the program.

An illustration of MediaNet speed; with data flowing out of the VBI "highway" into the decoder at rates near 300 kbps, if you told the software to "capture and store" every bit of material flowing through the decoder in 3.33 seconds you would fill 1 megabyte of storage space; in one minute 18 megabytes of memory. Or, in one hour, 1,080+ megabytes of memory (the equivalent of 720 normal discs).

The software provided allows more intelligent use of the material by creating the equivalent of a "search and locate" system. Using on-screen prompts the user tells the software what sort of information is required from Internet. For example, you might tell it to search for anything that relates to "satellites."

MediaNet is one-way simply because your decoder equipped satellite terminal (1) does not "transmit"; a feature to await the next generation of hardware. It is a high speed browsing system where you select "road signs" for "off ramps" on the Information Superhighway using the software. For each off-ramp selected, the data selected ends up in memory at your PC.

The cost for this wonder is to be in the range of DM15 per month. This compares with 1 hour Internet access

Deutsche Welle MPEG-2
from AsiaSat 2

MediaNet is carried in VBI of DW, video is fed from IRD to MediaNet decoder which installs between PC and printer. Decoder extracts Internet from VBI portion of DW TV signal.

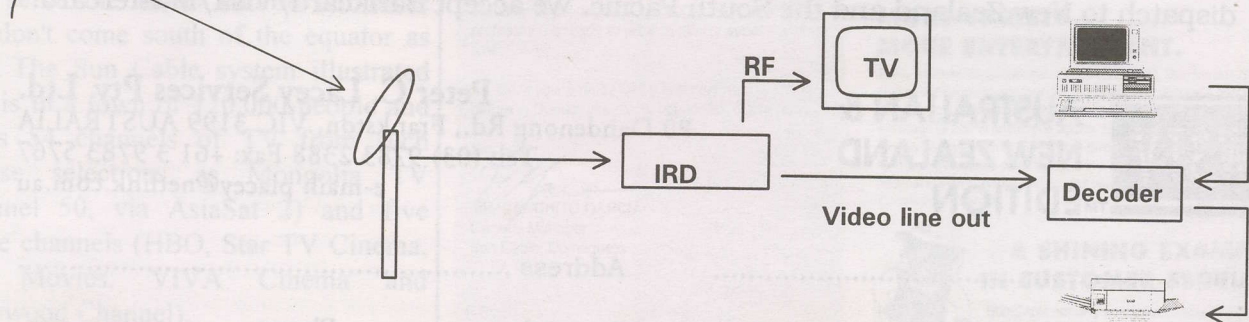



It Might Be Easier To Go Ahead And Reserve Your Spot At SPRSCS '97!

IF 1996 has been "*The Year of TVRO in the South Pacific*" - 1997 promises to be "**The Year of Digital + Internet**" for the South Pacific! AND in the Grand Tradition of putting you at the leading edge of new technology, SPRSCS '97 is building to be the greatest gathering ever!

Technology leaders and innovators from Europe, North America, Asia plus our own South Pacific professionals in the most stimulating collection of brains, hardware and software ever assembled. AND - several optional mini-seminars within the framework of SPRSCS '97: **January 21-22** - The Mark Long/SPACE Pacific Satellite Installer Course; **January 25**: Ku-DTH Installer Course; **January 25**: Internet via Satellite and Cable Symposium cosponsored by PC Magazine. If it is going to 'happen' in 1997, you will learn the details FIRST at SPRSCS '97!

IN A HURRY?

Fax SPRSCS '97 at 64-9-406-1083

NOT IN A HURRY?

Use SPRSCS '97 INFO CARD page 34

IF YOU CAN ONLY MAKE ONE SHOW in '97 - make it SPRSCS!

SatFACTS November 1996 ♦ page 15

AND NOW - a message from your sponsor.

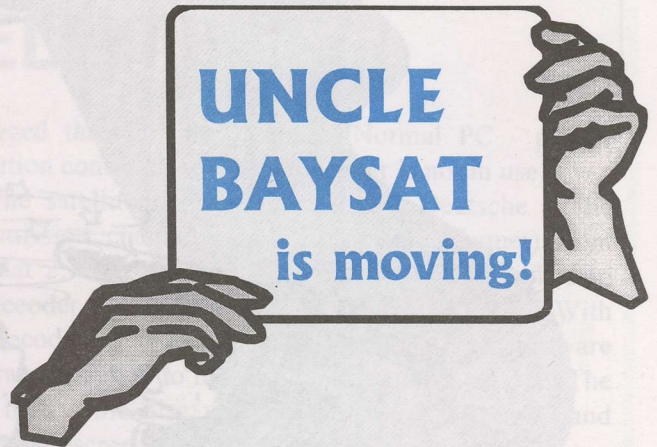

YES - Uncle Baysat has outgrown the present quarters in Hastings and tucking the 7 metre dish under his arm is shifting to bigger, brighter quarters just up the road a piece in Napier. This means better on-site control of inventory, faster delivery (we are already legendary for same-day shipping!), new office and inventory room and most important - room for a very impressive array of operating satellite dishes for C , Ku and Ka from very small to "Not in MY Backyard!".

IMPORTANT NEW NUMBERS FOR YOUR RECORDS

TOLL FREE (within New Zealand) > 0800 BAYSAT (0800 229 728)

INTERNATIONAL telephone > 64-6-843-5296

FAX (domestic and international) > 64-6-843-6429

Postal (mailed items) > PO Box 3311, Napier, New Zealand

SHIPPING (physical address) > 19B Carnegie Road, Onekawa, Napier, New Zealand

WEB Site (Brighter, more informative than ever!) > <http://www.baysat.co.nz/baysat>

e-mail (Still the lowest cost way to reach us!) > john@baysat.co.nz

AND -

We invite you to CONTACT US NOW for special invitations to attend our SPRSCS '97 "How to make money in satellite" seminars!

BAY SATELLITE TV LTD

YES!

We STILL accept VISA, Mastercard with no surcharge!

PO BOX 3311 • Napier • New Zealand • Tel toll free 0800 BAYSAT International 64-6-843-5296 • Fax 64-6-843-6429 (0800 229 728)

Physical location • 19B Carnegie Road, Onekawa, Napier

<http://www.baysat.co.nz/baysat>

e-mail john@baysat.co.nz

SL-8000RP

4500 years ago, the Egyptians were so far advanced in building technology that the pyramids were considered to be one of the Seven Wonders of the World. Today, still standing, these magnificent shrines to the achievements of man leave us marvelling at the skill and dedication of these ancient people. Fine craftsmanship is truly an ageless art.

Palcom receivers reflect skills and craftsmanship based on the same traditional values. The flagship of the Palcom range, the SL-8000RP is another marvel of technology.

From BC2500 to SL-8000RP

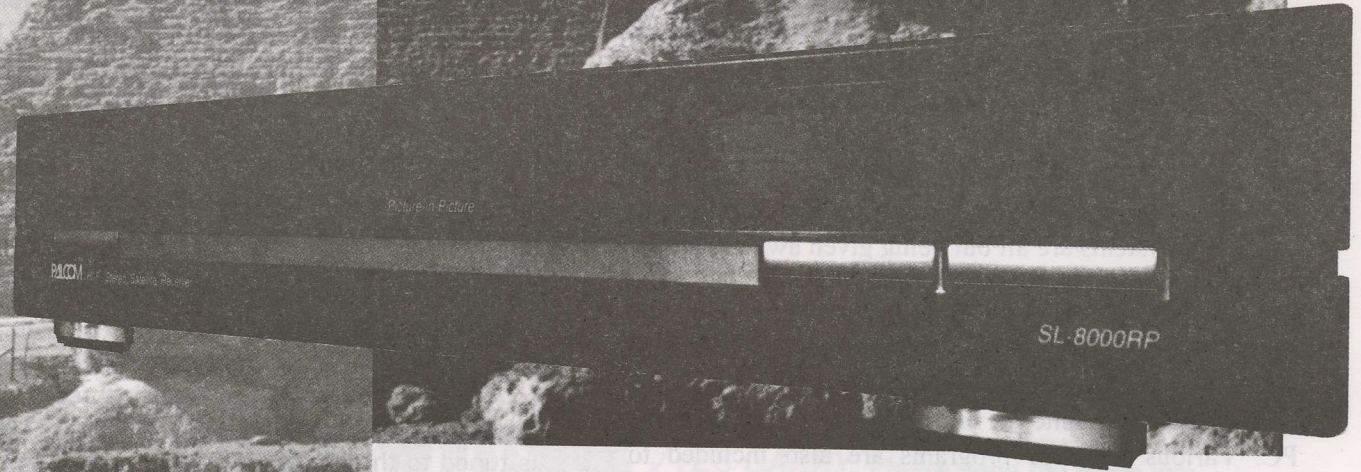

Its unique moving Picture-in-Picture feature permits the viewing of two channels at the same time (on one TV or two) or watching one channel whilst recording another. Mix images from satellite and terrestrial TV, satellite TV with VCR playback or satellite TV and security camera output with a choice of picture size for each image source.

The weakest signals may be viewed using the Palcom low threshold tuning facility producing improved video and audio performance.

A built-in antenna positioner provides access to all current satellites

500 Channels • 2 Tuners • 3 IF Inputs • Weak signal Video and Audio processing • HiFi 1600 • Stereo Audio processing (surround) • On Screen Display in 6 languages • Channel Naming • Satellite Naming • LNB Naming • Decoder Naming • 16 Local Oscillator presets (adjustable) • 22kHz Tone Switching • Global and Fine Ferro/Skew adjustment • Alphanumeric Channel List • Favourite Channel Function • 16 Preset External Decoder configurations • Internal VideoCrypt ready • Timer / Priority switching for TV and VCR

with software by....

PALCOM

State of the Art Simplicity

charges in the \$5 region except through MediaNet you have unrestricted usage 24 hours per day.

As magnificent as the 300 kbps is, this is hardly the world of maximum speed Internet. The size of the Internet universe, in mega-terra-giga bytes changes by the second. In the best case it is so sizeable that even at 300 kbps not everything buried within Internet will flow by your decoder very often. MediaNet recognises this challenge by doing selective editing of the Internet content via their VBI circuit. The exact parameters of their editing (what is left in, what comes out, how often this is changed) is a subject of ongoing debate within MediaNet. At this point in time the first users of MediaNet via Deutsche Welle will be participating in a form of "Beta testing" experiencing what MediaNet has selected on their own, and feeding back to MediaNet (unfortunately, through e-mail or other modem connected terrestrial circuits) their reactions to the content.

Having selected the web sites by name or topic material by key words ("Satellite") the MediaNet user is rewarded with instant response. That is because the software plus 10 MB of hard drive memory are dedicated to the task at hand. MediaNet has organised the data flow into "time segments" and they tell us a daily schedule will advise when new information will be available in hundreds of fields of interest. Because this is a marriage of Teletext and Internet, as a 'plus' we end up with 256 colour page displays laid out, they say, like "magazine pages with illustrations and artwork." A more detailed analysis of the MediaNet system and its computer requirements appears in this issue on op. 32; "At Sign-Off."

MEANWHILE In The USA

The Hughes/Thomson DSS (DirecTV) Ku-band service delivering nearly 200 possible channels of digital TV to 18" dishes in North America launched a companion DirecPC late in October. This service is very similar in form to the MediaNet service just described with some minor hardware differences. As reported in this issue, DirecTV pricing has dropped to the point where TV systems are all but being given away to attract new subscribers. DirecPC is starting off in pricing at the same level which initiated DirecTV 28 months ago; (US)\$699 for a 21" elliptical offset dish, LNB, cables and in place of the normal set-top IRD, a "PC card" that is designed to fit into an expansion port for the user's PC. Various software programs are also included to facilitate searching for and locating of specific web sites or topics.

The service does not utilise the vertical blanking interval of a TV programme signal; rather it is sent on a narrow slice of the Ku spectrum used by the Hughes satellites at a rate of approximately 400 kbps; typically

14 times faster than the best grade of terrestrial telephone modems (28.8 kbps).

In addition to the hardware costs (for reasons not fully explained an existing DirecTV receiving package is not usable; even for the antenna/LNB portion) for DirecPC, there are use charges. Once operational, the user has a variety of charging options. First there is US\$9.95 per month as a "user fee," equivalent to the DM15 user fee for MediaNet. Then there are per hour and bulk rated per month fees which DirecPC suggests will average around US\$40 per month for a "typical user." The fees announced to date do not seem to be significantly better than those US Internet users are now paying for terrestrial links. Of course at 14 times the data access rate, in theory a user can spend 1/14th as much time using the service to retrieve what they now access. Like MediaNet, this is a one-way service supported by search engine software although built into the satellite IRD is a modem that allows the user to communicate through the terrestrial network as well. In effect, 400 kbps incoming and 28.8 (or less) kbps outgoing.

Hughes has announced a similar DirecPC service will be available in the Pacific/Asia but has not set a time table. Hughes and PanAmSat are in the process of a merger at this time with the result that the Hughes constellation of 13 satellites and the PanAmSat group of 8 (1998) will become a "seamless entity" for interconnection of any point on the globe to any other. The initial target region for Asia is Taiwan and Japan although a Hughes spokesman told SF, "*We are also actively studying Australia as well.*"

All of this suggests satellite TV installers should begin now to understand this new service.

1/ The vertical blanking interval (VBI) portion of the Deutsche Welle service stays within the TV (video) signal even when the signal is demodulated and remodulated. Therefore the video "out" line to the decoder could also come from a TV receiver equipped with a "video out" jack on the rear apron.

Additionally, cable television systems carrying Deutsche Welle will be delivering MediaNet into cable subscribing homes as well because the two signals are not separated in the cable carriage process. This opens up the possibility that cable TV system subscribers can equip with the MediaNet decoder to recover the same service through their cable system. In this case the TV receiver or VCR is tuned to the Deutsche Welle cable service channel and "video out" connects to the decoder.

2/ SPRSCS '97 will include a four hour "Internet via Satellite" Symposium from 11AM to 3PM on Saturday January 25th. This symposium is jointly sponsored by PC Magazine New Zealand and SPACE Pacific and is intended for one-day attendees interested in this new delivery technology. A report on high speed Internet access via satellite and cable appears in PC Magazine (NZ and Australia) December/January issue.

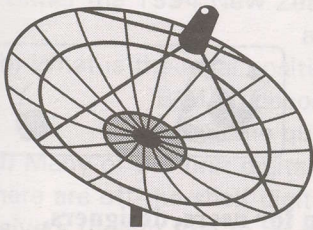

AV-COMM SATELLITE TV EQUIPMENT

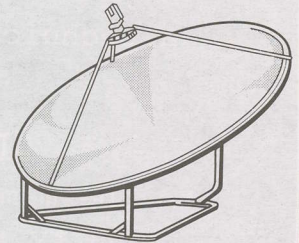

INTRODUCING THE DYNASAT 300P RECEIVER

*Plus Australian sales tax if applicable

ONLY
\$775*

CAT #R1152

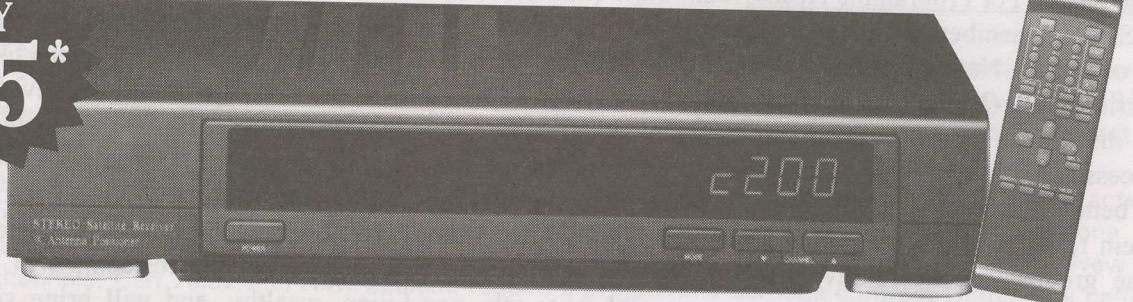

LOW THRESHOLD RECEIVER WITH DUAL AXIS POSITIONER

FEATURES

- 200 CHANNELS •••➤
- DUAL AXIS POSITIONER •••••➤
- DUAL INPUTS •••••➤
- SCART & RCA OUTPUTS •••➤
- DUAL BANDWIDTHS ••➤
- FREQUENCY SCAN •••••➤
- 14/18V SWITCHING •••••➤
- 20 STEP THRESHOLD EXT •••••➤

BENEFITS

- PRE-PROGRAMMED WITH 90 CHANNELS VIEWABLE FROM AUSTRALIA & 40 FROM NEW ZEALAND.
- FOR INCLINED ORBIT SATELLITES
- ALLOWS DUAL DISH/BAND OPERATION
- MAXIMUM INTERCONNECTION FLEXIBILITY
- SUITABLE FOR HALF TRANSPONDER OPERATION
- SEARCH FOR UNKNOWN FREQUENCIES
- USE DUAL POLARITY OR WIDEBAND LNB
- PRESET THE EXACT THRESHOLD FOR EACH CHANNEL

**We reserve the right to improve product performance without notice.*

AV-COMM PTY. LTD.

DIRECT IMPORTER ACN 002 174 478
PO BOX 225, BALGOWLAH 2093

TEL: 61 2 9949 7417 9948 2667

FAX: 61 2 9949 7095

VISIT OUR WEB SITE AT
<http://www.avcomm.com.au>

✓YES GARRY, Please send me more info...

Name: _____

Address: _____

_____ P'code: _____

Phone: _____

a technical and marketing
advisory

memo

to the membership from your
industry trade association

SPACE Pacific

Satellite
Programme
Access
CommittEe



**A trade association for users, designers,
installers, sellers of private satellite-direct
systems in the Pacific Ocean & Asia Regions**

The Search For Programme Access

SPACE members of Installer/Dealer grade and higher throughout New Zealand will be gathering at Christchurch (November 16) and Taupo (November 17) to discuss in closed session the status of programme access. This initiative is a first effort to assist members in better understanding why so many different "policies" seem to exist in the programming end of this industry. The groups will be relatively small and the sessions intense with open dialogue to encourage members to ask specific questions about programming sources which they have found difficult in obtaining programme access.

There are major, unresolved problems relating to access. New Zealand has modern copyright legislation adopted at the end of 1994. Australia struggles with legislation decades old and essentially unchanged from the days prior to television. New Caledonia, Fiji, Solomon Islands and other areas reached by SatFACTS and SPACE Pacific have either no legislation in place or rule by "executive order" on matters relating to satellite program access.

There is no one, single, statement about copyright that can describe the situation in two or more sovereign countries in the Pacific. No two are alike, each has idiosyncrasies which require local initiative and this usually means personal face to face meetings with government officials or judges to determine just what each country will allow. Some, such as New Caledonia and Fiji, simply will not allow what we think of as cable TV. On the other hand, under the "right circumstances"

both have approved what we would classify "SMATV" (satellite master antenna system). A recently "executive order" approved project in Fiji plans to use five or more dishes to provide 20+ satellite delivered channels to a "resort community" that is self-contained on a single island. The government officials explained they were "not authorising cable TV" in the resort, only allowing the project builders "to provide a master antenna service to residents." That the residents will be almost totally non-Fijian, wealthy, and will bring significant foreign capital to Fiji to support their lifestyles on their "private island" probably had a bearing on the decision.

As a practical matter, each programmer has its own internal distribution policy. ESPN, for example, has offered service to New Caledonia hotels and restaurants provided the establishments were willing to pay a minimum annual fee in the region of US\$3,500. We know of no similar offering made by ESPN to any other area in the Pacific.

At the Christchurch and Taupo meetings specific questions are being addressed and guidance being offered by an advisor to SPACE on copyright matters. The hope is that by participating in the sessions, installer/dealers, cable operators and others will be better equipped to know what they can and cannot do, what services they can offer and cannot offer, and where there are red danger flags stay away from any involvement in "grey market" programming which could result in penalties (financial and legal) for the system installer. Not every question has an easy answer and in some situations there will be "no answer at this

MEMBERSHIP IN SPACE

Membership in SPACE Pacific is open to any individual or firm involved in the "satellite-direct" world in the Pacific and Asia regions. There are four levels of membership covering "Individuals," the "Installer/Dealer," the "Cable/SMATV Operator," and the "Importer/Distributor/Programmer."

All levels receive periodic programme and equipment access updates from SPACE, significant discounts on goods and services from many member firms, and major discounts while attending the annual SPRCS (industry trade show) each January in Auckland. Members also participate in policy creation forums, have correspondence training courses available. To find out more, contact (fax) 64-9-406-1083 or use information request card, page 34, this issue of SatFACTS. Page space within SatFACTS is donated each month to the trade association without cost by the publisher.

SPACE Pacific Copyright Seminar Topics Being Discussed

- a) Under the 1994 New Zealand Copyright Act, what rights does an individual have to install a satellite dish and tune-in programming received by the dish system?
- b) What is the legal position of someone who goes outside of New Zealand, to Indonesia, to purchase a B-MAC decoder for private home use to receive HBO Asia and TNT/Cartoons?
- c) Same question - for a commercial establishment such as a pub or motel?
- d) Many of the first digital services being transmitted are NOT presently utilising conditional access. And there are off-the-shelf digital receivers available which tune in these broadcasts in the same way analogue receivers tune-in free to air analogue transmissions. Are these free to air digital signals any different for home use than free to air analogue?
- e) Same question but substitute a pub or motel for private home user.
- f) Australian Galaxy can be received in some portions of New Zealand if the proper equipment is installed. What is the legal posture of an individual in New Zealand arranging through Australia for a Galaxy decoder and smartcard to access Galaxy from here?
- g) Same question but substitute pub or motel.
- h) When digital services do employ conditional access, and establish a marketing scheme to sell subscriptions in areas outside of New Zealand, the effect is the same as with an individual in New Zealand accessing HBO Asia and TNT/Cartoons via a B-MAC decoder and subscription acquired outside the country. Does the fact that the signals are conditional access digital change the legal position of the user in any way?
- i) In the cable television area - Television New Zealand and TV3 have both created cable television contracts. Both are asking cable operators for a monthly fee, per channel and per subscriber. However, at least one major New Zealand cable firm (First Media) is known to not being paying a monthly fee to Television New Zealand for its channels. Can Television New Zealand require a programme carriage contract from some cable operators and not others, under the terms of the 1994 Copyright Act?
- j) First Media has decided NOT to cable carry TV3 in New Zealand because of a dispute over payment of copyright fees for "free to air" terrestrial signals. What should we make of this?
- k) NBC Asia has established a policy that cable operators must pay a minimum of US\$1,000 per month to be an affiliate; the equivalent of 1,667 cable subscribers. Does the act allow such discrimination against smaller cable systems?
- l) CNN is free to air on several satellites. Yet to become an affiliate of TNT/ Cartoon channel, the cable operator must agree to also pay for CNN as if it were a conditional access signal. Do they have a right to make TNT/ Cartoons conditional in this way?
- m) BBC World is available free to air digital on PAS-2 and other satellites. Television New Zealand warns cable operators NOT to carry it threatening to bring copyright suit if cable does carry BBC World. Are they within their rights here?
- n) Is cable TV, or SMATV in any legal jeopardy by placing free to air signals - whether they come in analogue or digital - on their cable systems in New Zealand?









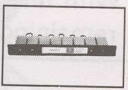

time." The session will be videotaped and scheduled within SPRSCS '97 as well. Because of the nature of the material, videotape copies will not be available (i.e., SPRSCS '97 attendees may view the tape but no copies can be made). A summary of the topics included in the meetings is included here.

SPACE is approaching decision time regarding bringing suit before the New Zealand Copyright Tribunal against one or more programmers. Members will be kept advised.

**FILTERS FOR ALL TV SYSTEMS
*YEAR #27!**

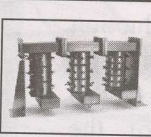
For Example

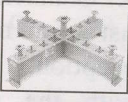
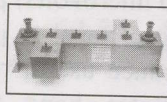
Free Catalogs

CABLE TV SYSTEMS  Channel Deletion  Channel Bandpass  Bandsplit + Your special needs			TVRO & PRIVATE CABLE  Low-Cost Deletion  Anti-Radar Bandpass  Block-Band Pre-Select + Your special needs		
MMDS - "WIRELESS TV"  Relay Antennas  Channel Combiners  Line Components			LPTV - "LOW POWER TV"  Channel Combiners  Transmitter Bandpass  Line Components		



Emily Bostick
President

Emily Bostick

Emily & Glyn Bostick -
*Continuing a generation of personal service to TV INDUSTRIES WORLDWIDE!



BOSTICK FILTER DIVISION
 7395 Taft Park Drive
 East Syracuse, NY 13057
 Mailing address:
 PO Box 3307
 Syracuse, NY 13220
 Tel: (315) 452-0709
 Fax: (315) 452-0732
 Canada & US: 800-882-1587

Contact our Distributor Maser Technology Group:
 New Zealand tel 64-9-479-7889
 Australia 61-2-9970-7644

The CABLE Connection

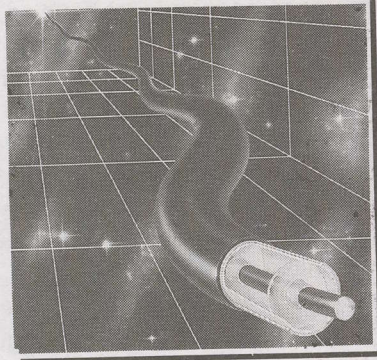

Selective signal delivery to subscriber TV sets was described in this column previously (SF July, August, September). There are numerous situations which require that only a portion of the cable spectrum be available to the connected TV sets although different sets may require differing "chunks" of the spectrum. As noted, one of the more economical approaches is to place a "full spectrum" onto the cable mainline (trunk) and feeder lines, and then house for house eliminate portions of the spectrum at the subscriber tap before it goes into the home.

In September we described the in-line filter, a A/NZ\$15 per unit device with the quite special ability to selectively "stop" some portions of the spectrum while simultaneously "passing" other portions. The combination of stop and pass are pretty much by user order: the full spectrum may be 50 to 550 MHz and any chunks within that broad bandwidth can be chosen to "pass" or "stop."

To illustrate, see the photos here. Top right, a 39 cable channel spectrum with 55.25MHz at the left and 447.25 at the right. Middle, same spectrum but with a 50-200 MHz low pass filter installed. All of the TV carriers above the cut-off frequency have simply disappeared, being "absorbed" by the filter. A TV receiver connected to the cable system after the filter would not receive those channels above 200 MHz.

A filter such as this is capable of rejecting signals above the "cut-off" by something in excess of 50 dB. A TV receiver connected to cable nominally receives 60 dBuV (1,000 microvolts) per channel; a 50 dB reduction drops the signal level to just a few microvolts - far too weak to produce useful reception. The bottom (right) photo illustrates how, with the sensitivity of the spectrum analyser increased, you still cannot "find" the TV signals above the cut-off frequency of the filter.

Small Town Cable - continued

As described in this column for October, it is entirely cost effective to serve a community of perhaps several hundred homes with no cable plant amplifiers. By carefully selecting the appropriate trunk and feeder line cable, and creating a headend with something approximating +108 dBuV (48 dBmV) output on the highest TV carrier frequency, your cable plant can be as

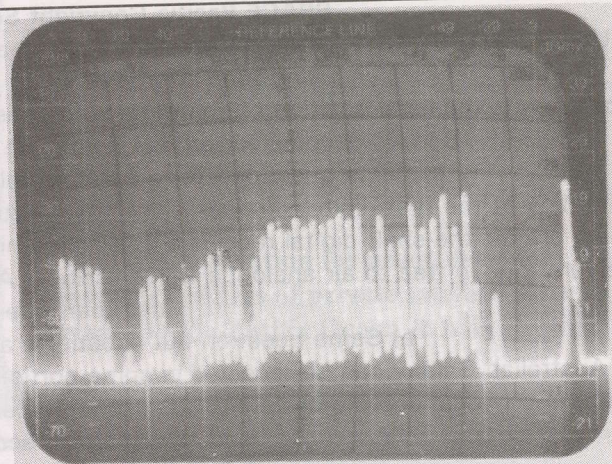

Spectral display showing 39 cable TV carriers from 55.25 MHz (left hand side) to 447.25 (right).

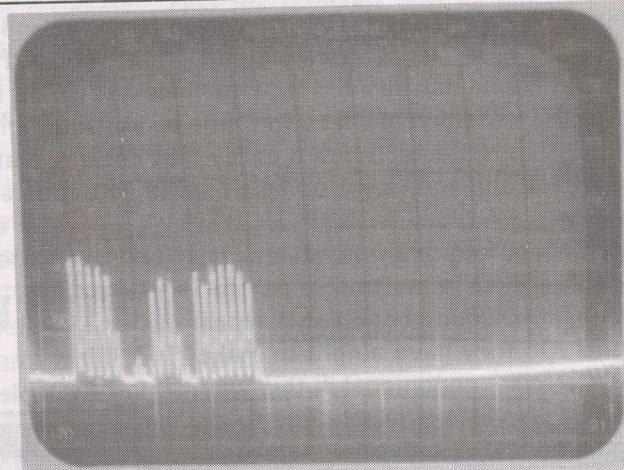
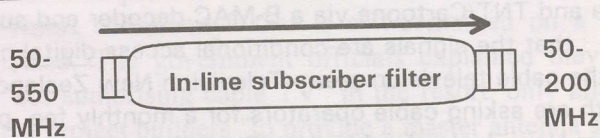

With filter installed - display shows 15 TV carriers remaining (eliminating all signals above 200 MHz)

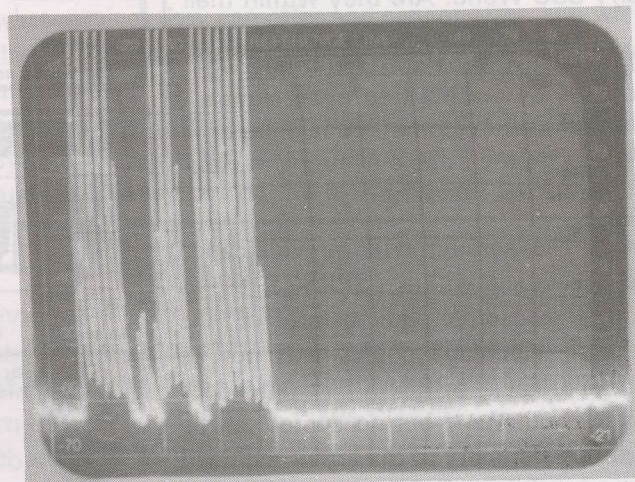

How far "down?" Top two displays are in 10 dB per graticule division. Here, 15 carriers remaining after the filter is installed are displayed at 2 dB per division. Carriers in cut-off region are "down" more than 50 dB; more than enough to eliminate service to TV sets above the cut-off frequency.

much as 2,000 metres in length. Or, as reported, if you elect only to utilise the spectrum below 100 MHz, the cable plant can extend for as much as 4,000 metres with no signal amplification beyond the headend equipment. Such "mini-cable" systems offer entrepreneurs the opportunity to create an income producing business which can, over time, grow into a sizeable self funding cable business.

Raising capital (dollars) to launch a cable system is a difficult task. Moreover, as is often true in business the people who have the know-how and drive to get on with such a new business often do not have access to the tens or hundreds of thousands of dollars required to launch the business.

Consider this option. Select a community or portion of a community with substandard off-air TV reception. Find a location near the community where terrain or other propagation factors allow you to create "clean" (strong, interference free) terrestrial TV reception. Now create a map depicting how much cable would be required to run from the off-air site to the community and around the community.

If the map shows you can reach the furthest part of the direct-reception sheltered community with no more than 4,000 metres of cable, by frequency transposing all of the off-air signals to a channel space between 55.25 and 83.25 then the system can be planned around the loss of cable at 100 MHz. If the first TV channel is 55.25 MHz there will be room for five channels to 83.25 MHz, six if

you use 90.25 and seven if you use 48.25. The beauty of this is that because you are using only the output "power" of the headend, the plant can be designed initially without any regard to amplifier selection or placement. In effect, the cable portion is totally "passive" (cable, line splitters, directional coupler tap-off devices). This reduces to approximately 50% the cost of the plant proper; a kilometre of cable installed by you with local assistance (i.e., no cable contractor) can easily come in at under A/NZ\$5,000. By charging A/NZ\$20 per month and signing up ten subscriber homes per kilometre, the cable will produce \$2,400 in a year per kilometre. To fatten up the cable offering, consider adding one, two or three easily captured satellite signals at the headend. The pay back period (out of debt for the cost of the plant) should run between 30 and 36 months; less time if the number of subscribers is greater than ten homes per kilometre.

What this does for you is simply this. You become a cable operator, using economical means to start the system, and by avoiding amplifiers within the plant you can then return once the system is generating revenue and expand the channel capacity simply by placing amplifiers where they are required to grow beyond the initial 100 MHz (top frequency) original design limit. And once you have an operating cable system, you are then in a position to grow the system into a reasonable business. Getting started is the tough part!



ORBITRON

Antenna Specifications

Model	Dia M	F/D Ratio	Gain dBi	
			4.2GHz	12.2GHz
SX8.5	2.5	.36	39.2	46.6
C10	3.0	.30	40.5	48.2
SX12	3.6	.36	42.2	49.5
O16	4.9	.30	44.9	52.1

distributed by

Sciteq Pty Ltd

ACN 009 235 090

33 Kentia Loop, Wanneroo, WA 6065, AUSTRALIA

E-Mail: pmerrett@omen.com.au <http://www.omen.com.au/~pmerrett>

Phone: ++61 9 306-3738

Fax: ++61 9 306-3737

SatFACTS Pacific Ocean Region Orbit Watch: 15 November 1996

Copyright 1996: SatFACTS, PO Box 330, Mangonui, Far North, New Zealand (Fax: 64-9-406-1083)

Free-to-Air 57E to 100.4E

Gemini TV	57E/703 1395RHC
Money TV	57E/703 1348RHC
Sun Movies	57E/703 1348LHC
Sun TV	57E/703 1220RHC
AsiaNet	57E/703 1170RHC
WorldNet	57E/703 1095RHC
NEPC	57E/703 1092/LHC
TVi	57E/703 1015LHC
Azerbaijdj.	57E/703 980LHC
Discovery India	68.8/Pas4 Vt/1360
Sony Ent.	68.8/Pas4 Vt/1239
Movie Club	68.8/Pas4 Hz/1117
CNN	68.8/Pas4 Vt/1061
TNT+	68.8/Pas4 Vt/1036
BBC World	68.8/Pas4 Vt/995
MTV & Jain TV	68.8/Pas4 Vt/966
TW6 Mos.	80E/1275
MAPTV	80E/1475
Moscow 1	90E/1475
Moscow 2	90E/1275
India 1	93.5/1025
India 2	93.5/1060
India 3	93.5/1420
CCTV	96.5/1325
Moscow 1	96.5/1475
Value Ch.	100.4/ 1488Vt

Free-to-Air 100.4E to 128E

RTPi	100.4/Vt 1167
TVB Mongolia	100.4Hz 1470
CCTV Henan TV	100.4/Hz 1422
CCTV Guandong	100.4Hz 1310
CCTV-4 Beijing	100.4Hz 1183
Moscow 1	103.1/ 1472
CFI	113/Hz 990
MTV Asia	113/Hz 1030
TPI	113/Hz 1070
TV Indosair	113/Vt 1090
ABN	113/Hz 1120
ANteve	113/Vt 1130
CNNI	113/Vt 1170
SCTV	113/Hz 1190
GMA	113/Hz 1230
TV3	113/Vt 1250
ATVI	113/Hz 1270
TVRI	113/Hz 1310
RTM	113/Vt 1330
RCTI	113/Hz 1350
CNBC	113/Hz 1530
JCSAT3 (test)	128/Vt 1166 & 12290Hz

Free-to-Air 130E to 174W

Saudi TV	140E/1275
Moscow 1	140E/1475
Udaya	142E/1225
EMTV	142E/1265
EagleNet	142E/1325
RAJ-TV	142E/1420
ASN	142E/1475
Moscow 1	145E/1475
NHK	169E/Hz 1115
CNN	169E/Hz 1183
Value Channel	169E/Vt 1400
CCTV-4 (MPEG)	169E/Hz 1426
RFO	180E/1105
WorldNet	180E/1179
CNBC	174W/Hz 990

S27 (Gorizont) 96.5E (RHC) +/- 1.5 deg

Jain TV	1,275
Muslim TV	1,425
Orbita II	1,475

S21 (Gorizont) 103.2E (RHC) +/-2.1 deg.

APNA	1,375
Orbita II	1,490

R41 (Gorizont) 153E (LHC) +/-0.9 deg.

This satellite, formerly at 130E, should be on station and testing soon with various Filipino programmers

AsiaSat 2 100.4E

Sky B-Mac	1130Vt
DW Bouquet (DVB MPEG)	1150Hz 1/DW 2/MCM 3/RAI 4/TVE 5/TV5
RTPi	1167Vt
CCTV-4	1183Hz
Reuters	1230Hz
STAR Japan DVB MPEG; not compliant	1250Vt 1/"Plus" 2/VIVA 3/Test 4/feeds 5/Sky London 6/Radio
CCTV-2	1310Hz
APT (MPEG)	1351Hz
Star Asian Movies (news-crypt)	1390Hz
STAR Asia (MPEG/CA)	1410Vt (see p. 26)
CCTV-1	1430Hz
STAR Asia (MPEG/CA)	1450Vt (see p. 26)
TVB Mongolia	1470Hz
Value Channel	1488Vt

Palapa C2M 113E

CFI	990Hz
Brunei	1010Vt
MTV Asia	1030Hz
ESPN (B-Mac)	1050Vt
TPI	1070Hz
TV Indosair	1090Vt
ABN	1120Hz
ANteve	1130Vt
HBO (B-Mac)	1150Hz
CNNI	1170Vt
SCTV	1190Hz
GMA	1230Hz
TV3	1250Vt
ATVI	1270Hz
TVRI	1310Hz
RTM	1330Vt
RCTI	1350Hz
(data)	1370V
TNT+ (B-Mac)	1390Hz
(data)	1410Vt
Discovery (B-Mac)	1430Hz
CNBC	1530Hz
STAR SE Asia MPEG	1570Hz
STAR SE Asia MPEG	1650Hz

Russian Polarisation
S (Stationar) series satellites are RHC (right hand circular); R (Rimsat) are LHC (left

NOTES:

C2M replaced C1 at 113E over period 28 June - 1 July. **Bold "OK"** NZ on 3m.
Russian R,S series satellites are inclined orbit;
+/- indicates extent of present inclination.

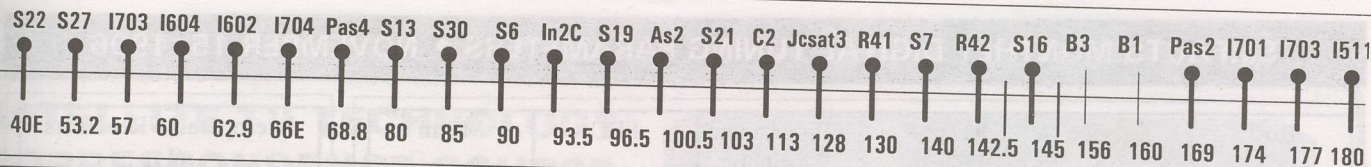

**OPTUS B3
156E
(Ku only)**

(B-Mac)	1425/Vt
Central ABC HACBSS	1393/Hz B-Mac
Vic. ETV	1361/Vt CryptV.
Imparja TV	1329/Hz B-Mac
(B-Mac)	1297/Vt
Net 9, Sky specials	1233/Vt B-Mac
Central ABC HACBSS	1201/Hz B-Mac
	1169/Vt
Galaxy	1137/Hz Irdeto Mpeg 2
	1105/Vt
Galaxy	1073/Hz Irdeto Mpeg 2
Golden West	1041/Vt
	1009/Hz
	977/Vt

**S7 (Gorizont)
140E (RHC)
+/- 4.4 deg.**

Saudi TV	1,275
Orbita I	1,475

**S16 (Gorizont)
145E (RHC)
+/- 3.9 deg.**

Moscow 2	1,275
Moscow 1	1,475

**OPTUS B1
160E
(Ku only)**

Net 9, Sky feeds	1425/Vt B-Mac
Data	1402/Hz
QSTV	1377/Hz B-Mac
NE ABC HACBSS	1370/Vt B-Mac
NE SBS HACBSS	1344/Vt B-Mac
SE SBS HACBSS	1339/Hz B-Mac
SE ABC HACBSS	1313/Hz B-Mac
Sky Channel	1296/Vt B-Mac
ABC Radio	1276/Hz (digital)
OmniCast	1270/Vt (FM/FM)
ABC feeds	1247/Hz Pal
Net 7	1244/Vt E-Pal
Net 9 feeds	1219/Vt Pal&Ntsc
	1214/Hz
Net 10	1182/Vt E-Pal
Net 9	1180/Hz E-Pal
Net 10 feeds	1155/Vt Pal
Net 7	1120/Vt E-Pal
Net 9 feeds	1091/Vt Pal
CAA air to ground	1009/Vt Nbfm
CAA air to ground	977/Vt Scpc(fm)

**PAS-2
169E**

CCTV ^{3,4}	1433.5/Vt (Sa9223)
Abn Ctn/Cctv/Nbc	1426/Hz (Sa9222)
Value Ch.	1400/Vt
Discovery PowerVu	1374/Hz (Sa9223)
MTV Asia	1346/Vt B-Mac
ESPN	1288/Vt B-Mac
MPEG-2 PowerVu Sylmar	1249/Hz (Sa9223)
TNT+ (1/2Tr)	1218/Vt B-Mac
CNN+ (1/2Tr)	1183/Hz
FoxSports	1161/Vt (Sa9222)
NHK	1115/Hz
Filipino Channel	1060/Hz (GI Mpeg)
NBC Mux MPEG	1057/Hz (Pace)
MPEG-2 PowerVu HonKong	1002/Vt (Sa9223)
TCS Sing.	967/Hz

PAS-2 Ku

PowerVu	12,415V
H-Life	12,520V

**R42 (Gorizont)
142.5E (LHC)
+/- 0.9 deg.**

Udaya	1,225
EMTV	1,265
EagleNet	1,325
RPN9	1,375
Sa9222	(1.5)
RAJ-TV	1,420
ATN	1,465

**Intelsat 701
174E**

Feeds	963
Feeds	984

**Intelsat 703
177E**

AFRTS	973 B-Mac *
Feeds	980

* uniquely left hand circular

**Intelsat 513
177W**

Feeds	963
Feeds	984

(513 Ku)

Service	RF Freq.
US Nets	10980Vt
NBC	11015Vt
Feeds	10510Vt

Ku Services
Intelsat Ku band services shown here are boresighted to Japan and nearby Asia, have not been reported south of equator. At boresight, signals of < 2m levels.

TDRS5 / 174.3W

CNBC	990Hz
BBC World	1190Hz MPEG

UPCOMING SATELLITE LAUNCHES

January '97/JCSAT-4 to 150E
January '97/ Indostar (S-band) to 106E
January '97/ ApStar 2R to ??E
February '97/ 11801 to 174E
February '97: Mabuhay to 144E.

**Intelsat 511
180E(W)
+/- 2.9deg.**

TVNZ	964/Ntl 3000
TVNZ	972/Ntl 3000
TVNZ	980/Ntl 3000
TVNZ	988/Ntl 3000
(data)	1,054
Canal +	1,054 **
(data)	1,092
RFO Tahiti	1,105
Asian	1,130
World-net	1,179
Aust. 9	1,220
Keystone	1,256
	1,277
Mpeg tests	1,310
Mpeg tests	1,325
Mpeg	1,388
Keystone	1,432

* RHC & LHC
** LHC only
e/ encryption

(511 Ku)

Service	RF Freq.
CBS	11480Hz
CNNI	11510Hz

TDRS5 "north" only

MISSING satellites: B2P now at 144E (no reports); C1 at 150.5E (data reported 1410Vt).

SatFACTS MONTHLY DIGITAL TUNING PARAMETERS ♦ NOVEMBER 15, 1996

Bird	Service	RF/IF & Polarity	# Programme Channels	FEC	Msym	Interoperable Receivers (1)
As2	EBB	4000/1150Hz	5TV, 13 radio, MediaNet (a)	3/4	28. 125	NTL, DGT400(2), DVR500, IRD520, SK888
	StarAsia CA test	3700/1450Vt	up to 6 TV (b)	3/4	28. 100	NTL(b), SK888
	StarAsia tests	3740/1410Vt	up to 6 TV (b)	3/4	28. 100	NTL(b), SK888
	STAR + service	3900/1250Vt	5TV, 1 radio (c)	3/4	28. 100	NTL, SK888
	APTV News	3799/1251Hz	1TV, 1 aux	3/4	5. 632	NTL, Comstream
R41/153E	DSP, Inc. Philippines	3705/1445 LHC	3TV (d)	3/4	4. 88	SA9222 today (temporary); shortly 9223 only
PAS-2	TCS Singapore-SA	4183/967Hz	2TV	1/2	6. 62	S-A PowerVu
	Discovery Singapore-SA	3776/1374Hz	6TV (3) (60)	3/4	19. 850	S-A PowerVu
	NBC HK-Philips	4093/1057Hz	7TV (e)	3/4	29. 473	NTL, DGT400(2), DVR500, IRD520
	SA California PowerVu	3901/1259Hz	7TV (f)	3/4	30. 800	S-A PowerVu
	SA California PowerVu	12415/1115 Vt	7TV (f) (g)	3/4	30. 800	S-A PowerVu
	CCTV China PowerVu	3716.5/1433.5Vt	2TV (h)	3/4	19. 850	S-A PowerVu
	SA HK PowerVu	4148/1002Vt	7TV (i)	2/3	29. 430	S-A PowerVu
Optus B3	Galaxy	12438Hz	20+ TV (j)	3/4	29. 473	DGT400, IRD520, SK888 (3)

1) Interoperable receivers: Receivers (IRDs) which have proven through repeated use to be capable of reliable digital reception for the programme services listed. 2) Pace (Galaxy) DGT400 units will function on these services ONLY if they have NOT been over-the-air "upgraded" to include the "programme Censorship" classification function. 3) Access to Galaxy programming requires a smartcard from Galaxy; such cards reportedly will also function with IRD520. Otherwise preview channel and TVSN are only services FTA.

(a) (1) Deutsche Welle, (2) MCM, (3) RAI International (no audio as of 07-11-96), (4) RTVE, (5) TV5 Paris; Radio channels: (1) DW #1 stereo, (2) DW#2 (stereo), (3) DW#3 (stereo), (4) YLE (left), RCI (right), (5) SRI(II), WRN(r), (6) REE, (7) DW#1 (stereo), (8) DW#2 (stereo), (9) DW#1 (stereo), (10) NN RA6, (11) NN RA8 + MediaNet [Internet] with Vertical Blanking Interval of DW TV on video programme ch. 1 (see SF#27, p. 14, 32); (b) Star Asia using their own version of MPEG(2) is testing up to 6 programme channels on these two transponders; conditional access when employed requires Pace DVS-211 receiver and companion smartcard. Occasionally testing can be seen on DMV/NTL 3000 without conditional access. (c) Video is subject to some variation but nominally includes: (1) Star + (Japan; NTSC), (2) VIVA Cinema (Philippines: NTSC), (3) CNBC (actually, test with static slide), (4) (horse) racing feeds (very occasional) to 'TCNA', (5) Sky News (London), (6) Star Radio; (d) At press time this remains SA MPEG 1.5 at 1375LHC on 142.4E but conversion to PowerVu and 153E is scheduled. At this time (1) ABC-5 (English), (2) RPN-9 (English), (11) test video; (e) (1) CNBC, (2) CNBC, (3) NBC Asia, (4) Colour bars - future use, (5) CNBC, (6) NBC Asia, (7) colour bars - future use [note: CNBC and NBC split feeds by programme channel for differing target area time zones (India, for example, is time-offset from Australia/New Zealand)]; (f) (1) CMT (NTSC), (2) CBS feeds, others; (3) ABC feeds, others; (4) ESPN2 (conditional access) NTSC, (5) BBC World (NTSC), (6) Bloomberg Financial (NTSC), (7) Golf Channel (NTSC) - note: EWTN/Eternal Word TV Network - will somehow fit into this bouquet December 8; (g) Ku feed of California PowerVu bouquet had disappeared from PAS-2 November 4 and may not return (was a test); (h) (1) CCTV4 (NTSC), (2) CCTV3 (NTSC) (these 2 services very difficult to receiver because of low eirp through transponder - if you can resolve these, your dish is working VERY WELL!); (i) (1) CTN News, (2) CTN Entertainment (conditional access), (3) TVBS HK and other feeds (NTSC), (4) CCTV-4 (NTSC), (5) NBC Asia, (6) ABN; (j) Galaxy access requires subscription smartcard which works with intended DGT400 IRD and from reports with Panasat IRD520 as well. Without smartcard DGT400, IRD520 and perhaps SK888 will also access free to air programme preview channel and TVSN shopping channel.

UPLINKING A PUZZLE?

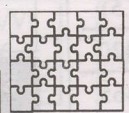

NEW ZEALAND'S ONLY PRIVATE TELEPORT CAN HELP!

SATELLITE TV TECHNOLOGY CORRESPONDENCE COURSE

The official technician certification course of the **SPACE—Pacific satellite trade association**

THE SATELLITE TV TECHNOLOGY CORRESPONDENCE COURSE is a complete home/office study program that has been expressly developed for students and professionals who wish to expand their knowledge and technical skills. The course consists of the *Satellite TVRO Handbook* and *Satellite TV Technology Overview* videotape, supplementary text materials on the latest technical developments in the Asia/Pacific Region, four take-at-home exams, a report card, and a certificate upon course completion. Students are able to proceed at their own pace and receive clarification from the course leader concerning specific course topics or ask questions on related topics.

THE SATELLITE TV TECHNOLOGY CORRESPONDENCE COURSE is taught by Mark Long, Founding Publisher of the *World Satellite Almanac*. Each of the four major course exams are mailed to registered students upon receipt of their written request for the exam materials. Completed exams are returned to the course leader for grading and suggestions for further study to clarify those points on each exam which the student may



CORRESPONDENCE COURSE VIDEOTAPE (ABOVE):
PART ONE: THE SPACE SEGMENT: Orbits & Orbital Assignments; Frequencies; Satellite Frequency Bands S/C/Ku/Ka; FSS vs BSS Satellite Frequency Assignments; Satellite Transponders; Satellite Polarization Formats; Satellite Communication Subsystems; and Interpreting Satellite Coverage Maps. **PART TWO: THE EARTH SEGMENT:** Antennas & Feedhorns; LNBS; Receivers and IRDs. **PART THREE: VIDEO AND AUDIO PROCESSING:** Video Standards - NTSC, Pal And Secam; HDTV; Video Encryption; Digital Video Compression; Digitizing Video; MPEG & MPEG DVB; MPEG Compression Techniques; MPEG Data Rates; Transmitting MPEG Via Satellite. **PART FOUR: INSTALLING SATELLITE RECEIVING SYSTEMS:** Antenna & Feedhorn Alignment; Installing Digital Receiving Systems. 60 minutes, PAL-VHS.

not have fully mastered. Upon successful completion of the four major exams, each student will be awarded a certificate of course completion.

THE SATELLITE TVRO HANDBOOK

written & compiled by Mark Long
 Founding Publisher of The **WORLD SATELLITE ALMANAC**

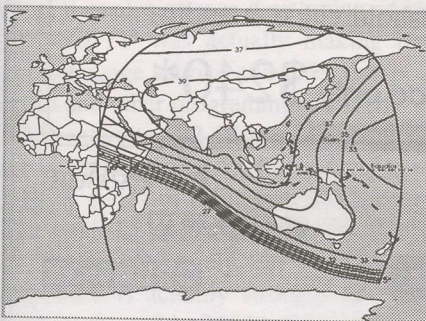

- ✓ INTERPRETING SATELLITE FOOTPRINTS
- ✓ SATELLITE FREQUENCY ASSIGNMENTS
- ✓ VIDEO & HDTV STANDARDS
- ✓ MPEG DIGITAL COMPRESSION
- ✓ TVRO SYSTEM DESIGN
- ✓ INSTALLATION PROCEDURES
- ✓ TRACKING INCLINED ORBIT SATELLITES
- ✓ SMATV SYSTEM OVERVIEW
- ✓ SOLAR & RAIN OUTAGES
- ✓ TERMINOLOGY GLOSSARY

THE OFFICIAL TECHNICIAN CERTIFICATION TEXTBOOK OF **SPACE Pacific** Satellite Program Access Committee
 The trade association of private satellite-direct systems in the Pacific Ocean Region

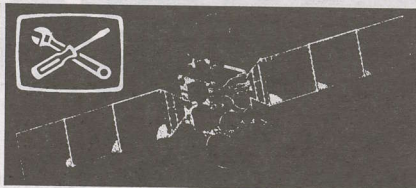

Available from **SPACE—Pacific** for NZ\$ 650, A\$600, or US\$ 394, **THE SATELLITE TV TECHNOLOGY CORRESPONDENCE COURSE** includes the basic course textbook, a one-hour course videotape, supplementary text and graphic materials, exams, a report card, a certificate upon successful completion of the course and all shipping and handling fees. Contact: **SPACE—Pacific**, PO Box 30, Mangonui, Far North, New Zealand. Fax: 64-9-406-1083

CORRESPONDENCE COURSE TEXTBOOK (Left): A comprehensive introduction to all aspects of satellite video and audio technology covering basic satellite terminology and the interpretation of satellite coverage maps; satellite subsystem overview; satellite telecommunication frequency assignments; video transmission and encryption standards, digital video compression and HDTV; international satellite earth station component guide; how to install satellite TV receive only (TVRO) systems, modified polar mount alignment; inclined orbit satellite tracking guide, SMATV system design; the effects of solar outages and rain fades on satellite system design, and a complete lexicon of satellite terminology. The official technician certification course textbook of **SPACE Pacific**. 212 pages illustrated.

The NextWave Has Arrived!!

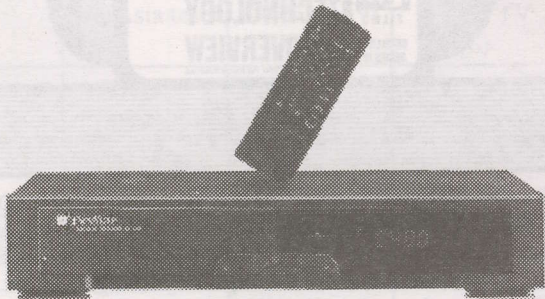

Nextwave EX-400 LT Satellite Receiver



Remote controlled, 400 Channels.
Don't be deceived by the price—this is a high quality satellite receiver.

\$185.00*

Nextwave EX-500 Satellite Receiver

On screen graphics, Low Threshold,
500 Channels.

\$260.00*

Nextwave EX-600 Satellite Receiver / Positioner

On screen graphics, Low Threshold,
Built-in actuator controller.

\$380.00*

Samart 2.3m Quad Mesh Dish

\$420.00*

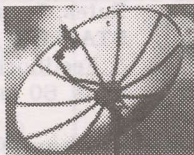

Samart 3.0m Quad Mesh Dish

\$560.00*

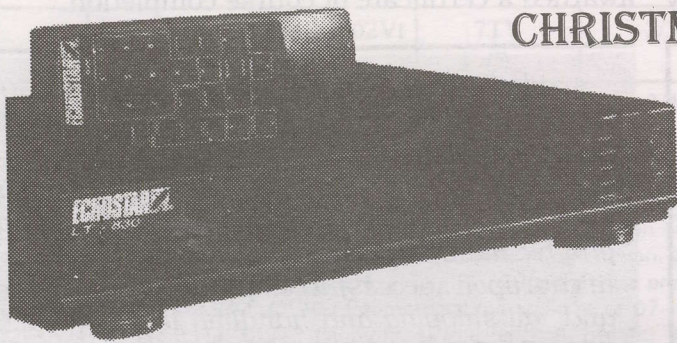

EchoStar LT-830

CHRISTMAS HAS COME EARLY!

The deluxe receiver of the
EchoStar range.

200 channels stored,
fully programmable, low
threshold video & audio.

Once only \$240*

ECHOSTAR

SAMART
INTERNATIONAL

Panasat
DIGITAL SATELLITE RECEIVER

Dealer Enquiries Welcome

*** ALL PRICES ARE QUOTED WITHOUT SALES TAX.**

NextWave

CHAFARRAL
COMMUNICATIONS

ORBITRON



NATIONWIDE ANTENNA SYSTEMS



ACN: 010 372 362

☎ 61 7 3252 2947
📄 61 7 3252 8541
💻 dargje@ozemail.com.au

📦 Nationwide Antenna Systems P/L
17 Campbell Street,
Bowen Hills, Qld., Australia 4006

WITH THE OBSERVERS

AT PRESS DEADLINE

RAI International married audio to their video (see p. 2, here) November 7th. On the EBB, all five TV services have audio on the left channel while RAI and TV5 typically do not transmit regular audio on their right channels. Both are exploring possibly sending separate radio audio on the right channel.

RAJ-TV, the Tamil language Indian service that until mid-October inhabited Rimsat G41 (130E), in moving to 142.4E leaves behind a small but fiercely loyal group of supporters in the Pacific. The RAJ powerhouse signal, once described by SatFACTS as "*perhaps the most powerful satellite transponder in the world, in terms of coverage and reach,*" was a mostly dependable 24 hour per day service which thousands of satellite enthusiasts in the Pacific recall as their "*first satellite reception.*"

It was difficult to miss RAJ on the 130E global beam. The 3675 MHz RF carrier backed by a 75 watt transponder made it unique in the satellite world. Many observers in the Pacific found delight in proving and reproving how small a satellite antenna could be, for C-band, and still produce quality pictures. If a dish couldn't produce RAJ, it probably wouldn't work on anything else either!

M. Raajhendran (the "RAJ" of RAJ-TV) visited SatFACTS in April 1995 as we reported in SF#9. He and cohort Shankar Karikar were totally unaware their transponder happened to be so powerful and were amazed to visit homes in New Zealand which displayed RAJ-TV reception with the same clarity as they were accustomed to in their homes in Madras. Following their visit many months of fax, telephone and written exchanges attempted to put together a "programming plan" for RAJ-TV that would take advantage of their huge coverage area beyond India. As Raaj repeatedly noted during the visit, "*I believe our being (randomly) assigned such a powerful satellite (channel) is a 'message' and we must find a way to make the best use of it.*" At one point there was a quite feasible plan to turn 12 hours each day into Asia/Pacific programming designed to appeal to viewers in English as well as non-English speaking regions. Alas, back home in India the cable TV explosion was developing so rapidly that by August 1995 RAJ-TV was actually making money from just their Tamil language service and from that point onward interest in English and other programming waned.

RAJ's move to 142.4E was telegraphed late in September by a crawl message "To All Cable Operators" running across the screen. A series of cable operator meetings explained to their Indian cable op target audience the mechanics of moving to a new satellite. Strangely, for south-eastern India, the 142.4E transponder is actually stronger than the 130E super power global reach world of 3675. Of course for viewers south of the equator, as well as in Japan the move meant the end of

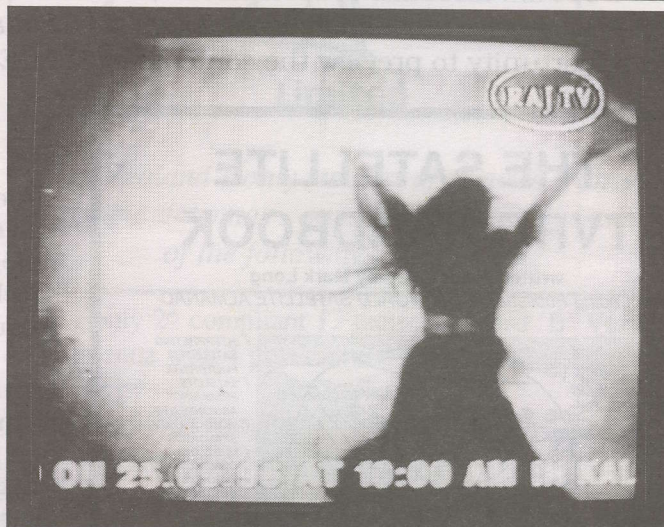

Crawl announcement across bottom of screen, in English, advised Indian cable operators to attend meeting September 25th sponsored by RAJ-TV

RAJ-TV. A pity because many thousands of non-Tamil speaking viewers had grown very fond of the elaborately produced music videos and the zany Marx-Brothers-like home grown comedies that filled RAJ daily. Nothing, however, will ever replace the 'RAJ TV Shopping Programme' and the dapper man who demonstrated children's toys. As he casually chased battery driven toys that insisted on leaving his demonstration table as if under alien control and determined to escape the TV studio, many a grownup has been reduced to fits of laughter, tear stained cheeks and holding their sides to keep from collapsing. Nothing ever seen on TV from anyplace was ever more unintentionally hilariously presented. Mr. Raaj - we will miss all of this and more and may you someday return to the Pacific television world!

Russian Express 6 began testing at 80E late in October producing a rash of "strong signal" reports in European and Indian satellite worlds. Of interest, no reports to our press-time from SatFACTS readers suggesting the transponders first tested have been primarily those with northern zone footprints. Express has global and quasi-global coverage on 8 C-band transponders including 3675, 3725, 3775, 3825, 3875, 3925, 4025 and 4125 MHz (find IF by subtracting above numbers from 5150); RHC (see SF#24, p. 6).

WITH THE OBSERVERS: Reports of new programmers, changes in established programming sources are encouraged from readers throughout the Pacific and Asian regions. Information shared here is an important tool in our ever expanding satellite TV universe. Photos of yourself, your equipment or off-air photos taken from your TV screen are welcomed. TV screen photos: If PAL or SECAM, set camera to f3.5-f5 at 1/15th second with ASA 100 film; for NTSC, change shutter speed to 1/30th. Use no flash, set camera on tripod or hold steady. Alternately submit any VHS speed, format reception directly to SatFACTS and we will photograph for you. Deadline for December 15th issue: December 3 by mail (use form appearing page 34), or 5PM NZST December 4th if by fax to 64-9-406-1083.

PURCHASE THE OFFICIAL SPACE PACIFIC TECHNICAL CERTIFICATION COURSE TEXTBOOK & RECEIVE A COUPON WORTH \$75 OFF THE ENTIRE CORRESPONDENCE COURSE PRICE.

SPACE PACIFIC, in cooperation with satellite expert Mark Long, has developed a correspondence course for satellite professionals that provides essential training in all technical aspects of satellite TV technology. FOR A LIMITED TIME ONLY, SatFACTS readers who initially purchase the course textbook will also receive a special discount coupon worth \$ 75.00 off the US\$ 394 retail price of the complete certification course AND receive our *new universal satellite azimuth/elevation angle calculation chart*. Take advantage of this opportunity to preview the contents of SPACE Pacific's new technical certification course today!

THE SATELLITE TVRO HANDBOOK

written & compiled by Mark Long
Founding Publisher of The WORLD SATELLITE ALMANAC

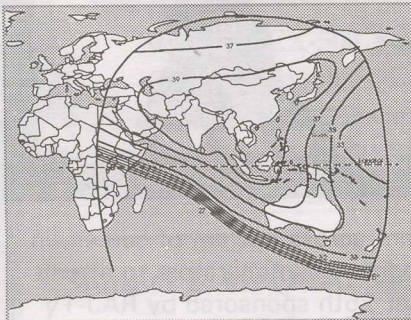

- ✓ INTERPRETING SATELLITE FOOTPRINTS
- ✓ SATELLITE FREQUENCY ASSIGNMENTS
- ✓ VIDEO & HDTV STANDARDS
- ✓ MPEG DIGITAL COMPRESSION
- ✓ TVRO SYSTEM DESIGN
- ✓ INSTALLATION PROCEDURES
- ✓ TRACKING INCLINED ORBIT SATELLITES
- ✓ SMATV SYSTEM OVERVIEW
- ✓ SOLAR & RAIN OUTAGES
- ✓ TERMINOLOGY GLOSSARY

THE OFFICIAL
TECHNICIAN
CERTIFICATION
TEXTBOOK OF
SPACE Pacific
Satellite
Program
Access
Committee
The trade association of
private satellite-direct systems
in the Pacific Ocean Region

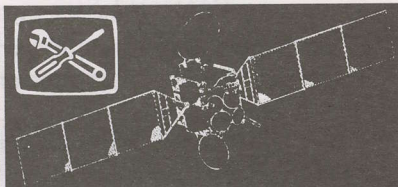

THE SATELLITE TVRO HANDBOOK

written and compiled by Mark Long

A comprehensive introduction to all aspects of satellite video and audio technology covering basic satellite terminology and the interpretation of satellite coverage maps; satellite subsystem overview; satellite telecommunication frequency assignments; video transmission and encryption standards, digital video compression and HDTV; international satellite earth station component guide; how to install satellite TV receive only (TVRO) systems, modified polar mount alignment; inclined orbit satellite tracking guide, SMATV system design; the effects of solar outages and rain fades on satellite system design, and a complete lexicon of satellite terminology.

THE SATELLITE TVRO HANDBOOK is a stand-alone reference that satellite professionals will refer to time and time again. Executives and Sales personnel will learn all of the key technical aspects that they will need to fully understand to best serve their customers as well as gain technical knowledge applicable to new emerging marketing opportunities within the entire Asia/Pacific region. Installers will learn how to conduct preliminary site surveys and streamline the installation process to cut installer time and achieve the pin-point accuracy required for minimum customer callbacks. 220 pages illustrated. Includes new universal satellite azimuth/elevation angle chart!

About the SPACE PACIFIC SATELLITE TV TECHNOLOGY CORRESPONDENCE COURSE: includes the course textbook, a one-hour *Satellite TV Technology Overview* videotape, 50 pages of Supplementary Course Materials summarizing the very latest industry developments, Course Exams, and Certificate of Graduation upon course completion.

**THE ESSENTIAL TVRO EQUATION:
TECHNICAL KNOWLEDGE =
INCREASED SALES &
CUSTOMER SATISFACTION**

Check Enclosed Bill Visa

Circle One: US\$ 75 Aus\$ 102 NZ\$ 105

Name: _____

Company: _____

Address _____

City _____ State _____

Zip _____ Country _____

Tel: _____ Fax: _____

Visa :# _____

Exp. Date: _____ Signature: _____

(Not available for sale or shipment to customers located anywhere in the United States.)

Yes! Send me **THE SATELLITE TVRO HANDBOOK** (US\$ 75; Aus\$ 102; NZ\$ 105; inclusive of all shipping and handling fees) together with the new *universal satellite/elevation angle calculation chart* and Correspondence Course discount upgrade certificate (worth US\$ 75 off total course price and valid for six months from the date of textbook purchase).

Mail form together with payment to:

SPACE Pacific
P.O. Box 30, Mangonui,
Far North, New Zealand
(VISA Orders—> Fax: 64-9-406-1083)

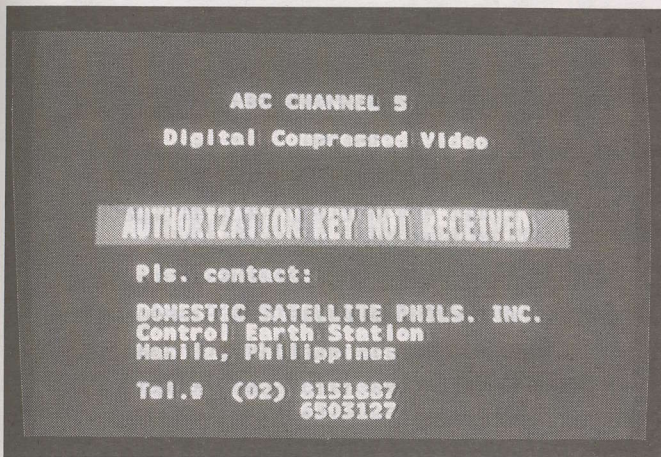

NOW you see it - now you don't. Temporary 142.4E IF1375 S-A MPEG 1.5 (D9222 receiver) format programming from Philippines includes two mostly English language services; RPN-9 and ABC-5. Both are changing out to PowerVu "soon" and moving to 153E (see text).

Steffen Holzt (New Caledonia) reports successful reception from Optus B3 Galaxy service using 3m Ku-rated Australian built dish. Signal, however, is subject to momentary dropout and he believes another 2dB of system antenna gain might do the trick.

Filipino RPN-9 and ABC-5 are sharing an MPEG 1.5 (S-A format) bouquet on IF of 1375 on 142.4E. The service can be identified but not accessed using a D9222 receiver at this time (see photo and caption, above). One Filipino source tells SF that when the two services shift to 153E and PowerVu, the parameters will be: IF1445, symbol rate 4.88, FEC 3/4. If (and that is *if!*) these numbers are correct, the 1445 transponder could be in the upper half of RAJ's old IF1475 powerhouse global beam pattern service. And that would certainly play south of the equator. So keep an eye peeled on 153E for signs of activity there.

David Leach, others in NSW and Queensland reports P2/P3 reception from CNNI (IF1170) and other vertical side transponders from ApStar 1 at 138E. This is a change, perhaps caused by repointing the satellite which previously was not even detectable except in far northern Australia.

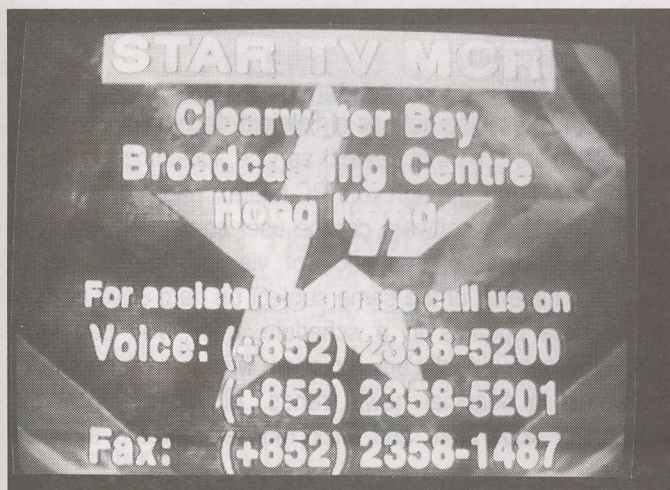

Robin Colquhoun (Auckland), others report STAR TV's AS2 3700 and 3740 MPEG test bouquets recently shifted from FEC 1/2 to 3/4 with many test signals seen late in October.

P
A
C
I
F
I
C

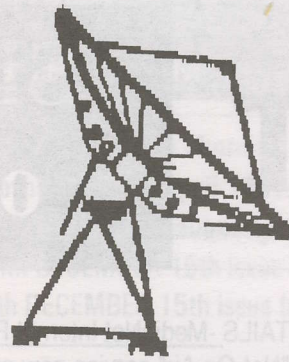

Limited

A
N
T
E
N
N
A
S

New Zealand's only stockist of preused transmit capable antennas - our stock presently consists of the following equipment:

- 1 only 2° compliant 13 metre standard 'B' Vertex antenna with 4 port circular feed and Cassegrain sub-reflector
- 1 only 3° compliant 10 metre Scientific-Atlanta antenna with 2 port linear feed and Cassegrain sub-reflector
- 1 only 4.6 metre Andrew Ku Band antenna with 2 port feed and Gregorian sub-reflector
- 3 only 5 metre Sat Com Technologies transmit rated Ku band antennas
- 1 only 3.7 metre Comtech transmit antenna with Seavey transmit feed horn

A selection of receive and transmit electronics including tracking equipment and motor drives with 15 to 50 ton azimuth and elevation jack screws.

Pacific Antennas Limited is the major stockholder in New Zealand Teleport Holdings Limited, a teleport 90% construction completed. This facility has a standard 'B' 13 metre Vertex antenna with auto tracking capabilities. These companies can individually or collectively joint venture, lease, sell, operate or install all of the above equipment. We have the necessary licensing in place and the hardware has been installed for New Zealand's first privately owned independent standard 'B' uplink teleport. To learn more about business opportunities available, contact **Bryon G.G. Evans.**

Pacific Antennas Limited

PO Box 265 • Whangaparaoa (Auckland), NZ
Tel/fax 64-9-424-0841 / Mobile 025-789-160

AT

Sign off

TECHNICAL DETAILS -MediaNet Internet Package

The MediaNet "Net On Air" service now on offer through the Deutsche Welle transponder on AsiaSat 2 requires some basic understanding of how high speed data can be married to a television signal and then transmitted world-wide via satellite.

MediaNet turns out to be a clever reconfiguration of selected Internet materials organised as "electronic magazine pages" using the full colour capabilities of a PC and monitor. The user receives a box containing the following:

- ✓ Multifunctional decoder
- ✓ Software package
- ✓ Adapter (SCART) lead (please also see enlarged report beginning on p. 14 of this issue of SatFACTS)
- ✓ (parallel) Connecting cable
- ✓ Instruction manual (one hopes it is in English!)
- ✓ Net On Air "reception license"

In the standard configuration, the decoder is connected to a SCART plug on the satellite receiver. Lacking a SCART output, the user will need to do some video lead configuring to make the connection.

MediaNet Net On Parameters / Requirements

- Satellite: AsiaSat 2 (100.4E)
 - Transponder: European bouquet (4000 horizontal; IF1150)
 - Programme channel: Deutsche Welle, #1
 - Receiver format: Any MPEG-2 (free to air capable) IRD (integrated receiver decoder)
 - Analogue reference: If CCTV on IF 1310 or 1430 horizontal is "clean" in analogue, MPEG reception from European bouquet should also be clean
 - Bonus to Net On Line: In European bouquet, 5 TV programme channels (Deutsche Welle, MCM Music, TV5 Paris, RAI International, RTVE Spain) + 13 radio service channels, all with same receiver tuned to same IF
 - PC should be 386 processor or higher, and,
 - Equipped with Windows 3.11 or higher (i.e. Windows 95)
 - Parallel interface (printer connection goes to Net On Line decoder)
 - 10 MB of free hard drive memory for programme + memory to receive the Net On Line data flow
 - VGA card with 256 colours or more
 - Mouse
 - 3.5" disc drive
- Net On Line decoder is driven by video output line from IRD when tuned to Deutsche Welle service

NOT COMING TO A NEWSAGENT NEAR YOU!



The new 1996 AV-COMM SATELLITE TV CATALOGUE, contains up to the minute information on all available satellites and equipment needed to receive them.

Contains detailed information on over 200 products covering all aspects of Satellite Television Reception.

For your FREE copy of the new 1996 AV-COMM CATALOGUE simply complete the coupon and send to: AV-COMM PTY. LTD. P.O. Box 225, Balgowlah NSW 2093.

YES Garry, please send me a FREE copy of the 1996 AV-COMM Satellite TV Catalogue.

Name: _____
Address: _____
P'code: _____
Phone: () _____

AV-COMM PTY LTD
A.C.N. 002 174 478
198 Condamine Street,
Balgowlah NSW 2093
Tel: (02) 9949 7417/9948 2667
Fax: (02) 9949 7095

Internet is 'edited' for "family use" and a daily schedule advises when various segments of Internet are available. Using the software, you select what you want to review by entering search words, web site addresses. It is akin to a TV "program schedule" in this way as certain subjects or topics appear to the scheduled at various times of day. However, with the software in place, you need only tell it what you wish and it will do the rest unattended.

In addition to the Net On Air Internet, you will also receive monthly:

- ✓ Access to on average 1,000 'shareware' packages per month covering a variety of interests (from games to data protection programs)
- ✓ Detailed Deutsche Welle programming guides
- ✓ The decoder also acts as a Teletext decoder for all other channels offering normal teletext service, including the ability to display and print through your PC teletext pages

The Net On Air software can be user configured to create your own save files, sequence of viewing, compilation of continuing material of the same subject on hard drive or disc. As the data updates to a schedule, daily, you can build ongoing files on virtually any topic you wish from sport scores world-wide to financial news trends. All of this is at the direction of your point and click mouse operated software program.

Information?

At SPRSCS '97 in special sessions January 23/24 and 25, from AV-COMM (Australia) and Bay Satellite (NZ) or from Thoma Net On Air at fax 49-9855-9777-20.

THIS IS THE PLACE!
SUBSCRIBE TO SatFACTS USING THIS FORM

A most incredible year to date - more than 50 new television programme channels available and for properly equipped and located viewers in the South Pacific, another 50+ by April 1997. **TO STAY INFORMED** of the South Pacific satellite revolution enter your SatFACTS subscription **TODAY!**

- ENTER my 12 MONTH subscription to SatFACTS starting with DECEMBER 15th issue (rates below)
 ENTER my 36 MONTH subscription to SatFACTS starting with DECEMBER 15th issue (rates below)

NAME _____
Company (if applicable) _____
Mailing Address _____
Town/City _____ Country _____

Amount to send: 1 year - NZ\$40/A\$75/\$US40 (outside NZ and Australia) or 3 years - NZ\$100/A\$175/ US\$100 if by cheque. **VISA?** See form below and return with order. Return to: **SatFACTS, PO Box 330, Mangonui, Far North (NZ)** or if by **VISA** by FAX to 64-9-406-1083.

USE THIS FORM ONLY WHEN CHARGING ON VISA CARD
(and PLEASE ALSO COMPLETE TOP PORTION AS WELL!)

Please charge my VISA card as follows:

- One Year of **SatFACTS MONTHLY** (NZ\$40/A\$75/US\$40)
 Three years of **SatFACTS MONTHLY** (NZ\$100/A\$175/US\$100)
 SATELLITE TELEVISION: The Booklet (NZ\$10/A\$12/US\$10)
 One year of **COOP'S TECHNOLOGY DIGEST** (NZ\$125/A\$125/US\$125)
 The **WORLD of SATELLITE TV-1992 edition** (NZ\$15/A\$20/US\$20)

Name (as it appears on **VISA** card) _____

VISA Card Number: _____ - _____ - _____ - _____

VISA Card Expiration date: _____

Instructions: If ordering by mail, return this complete (3-part) card (SatFACTS, PO Box 330, Mangonui, Far North, New Zealand); if ordering by FAX, send full card as single sheet to 64-9-406-1083.

SUPPLEMENTAL MATERIALS from SatFACTS MONTHLY: Order Form

- SATELLITE TELEVISION:** The Booklet. Excellent introduction to home dish ownership for the layman with contributions from world famous science writer *Arthur C. Clarke*. The perfect tool to help the system seller explain dish ownership to prospective customers, from **SPACE Pacific**. NZ\$10/ A\$12/ US\$10 by fast post.
- COOP'S TECHNOLOGY DIGEST.** For the really serious enthusiast, investor, business person in satellite TV and allied industries. Ten issues per year, jam-packed with information you will not find anyplace else. "Coop" routinely culls more than 60 monthly publications, \$1,500 per year newsletters, Internet and his hundreds of private contacts to keep you up to date on the **REAL** changes underway in telecommunications. Conveniently issued near **first** of the month, provides excellent time-line-filler between mid-month issues of SatFACTS. Now in 4th year, airmail world-wide. Normally NZ/A/US \$250 per year; for limited time 50% off offer at NZ/A/US\$125.
- WORLD OF SATELLITE TV - 1992 edition.** The famous *Mark Long* handbook that takes a novice and turns him or her into a satellite TV pro! 1996 edition \$45 or more; this special offer only NZ\$15/A\$20/US\$20.

OBSERVER REPORTING FORM - Due DECEMBER 3, 1996

- **New programming** sources seen since November 1st: _____
- **Changes** (signal level, transponder, programming content) in pre-existing programming sources since November 1st: _____
- **Other** (including changes in your receiving system): _____

Note: Please use P1-5 code when describing reception quality and receiver IF or RF settings.

Your name _____
Town/City _____
Make/Size dish _____ LNB _____ Receiver _____

Mail: SatFACTS, PO Box 330, Mangonui, Far North, New Zealand. **Fax:** 64-9-406-1083

REPORTING FORM REFERENCE CARD (Save for future use!)

-ANALOGUE SIGNAL REPORTING-

- P5** ▶ Fully above threshold (no sparklies, tearing) in 27 or greater bandwidth
- P4** ▶ At or above threshold with reduced bandwidth
- P3** ▶ With reduced bandwidth, some sparklies but still satisfactory DTH viewing
- P2** ▶ Significant noise in video, noise in audio even at reduced bandwidth
- P1** ▶ Must be an "enthusiast" to watch!

-DIGITAL SIGNAL REPORTING-

- DP5** ▶ Never a hint of "mosaic tiles" or free framing, studio quality at all times
- DP4** ▶ Occasional mosaic tiling, freeze framing (no more often than 4 times per hour)
- DP3** ▶ Mosaic tiling, freeze framing typically 5 to 10 times per hour
- DP2** ▶ Mosaic tiling, freeze frame (dropout) so frequent as to be annoying
- DP1** ▶ Reception mostly will not lock but does occasionally briefly lock

CREDITS: To Steffen Holzt, Noumea, New Caledonia
who conceptualised the use of P1 - P5 coding.

SOUTH PACIFIC REGION SATELLITE & CABLE SHOW REGISTRATION SLOTS ARE GOING VERY FAST!

THE GREATEST SHOW in the Pacific this year for satellite and allied areas of interest. Speakers from Europe, North America, Asia and the Pacific. Hands-on sessions designed to equip you for the explosion in digital delivery and Internet via satellite coming during 1997! ALL ENTHUSIASTS are invited to attend - whether members of SPACE or NOT!

YES - send me SPACE SPRSCS '97 show packet!

I am am NOT a member of SPACE Pacific.

NAME _____

Address _____

Town/City _____

Return to: SPACE Pacific, PO Box 30, Mangonui, Far North, New Zealand or fax to 64-9-406-1083

RELY ON PROMAX!

YOUR leading performer in the TV and AUDIO business.

PROMAX Signal Strength Meters for:

- FM ■ UHF ■ VHF
- SATELLITE ■ CABLE TV

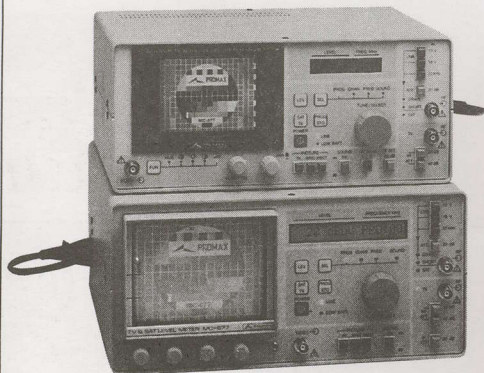
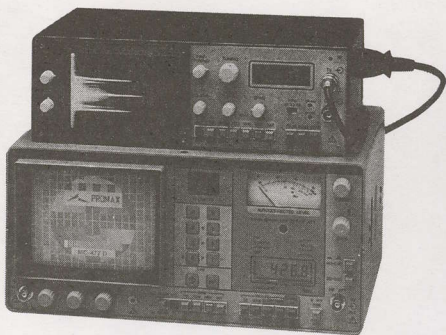

Gough Technology supply leading brands in their respective fields. With ISO 9002 certification, our customer sales and support service is guaranteed to meet your highest expectations.

PROMAX top quality test and measurement equipment:

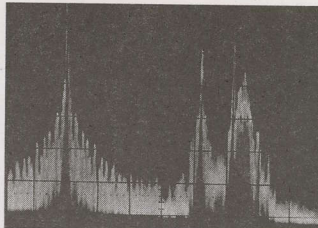

- SPECTRUM ANALYSERS
- MILLIVOLT METERS
- DISTORTION METERS
- AUDIO TESTERS
- PATTERN GENERATORS
- LOW DISTORTION LF GENERATORS

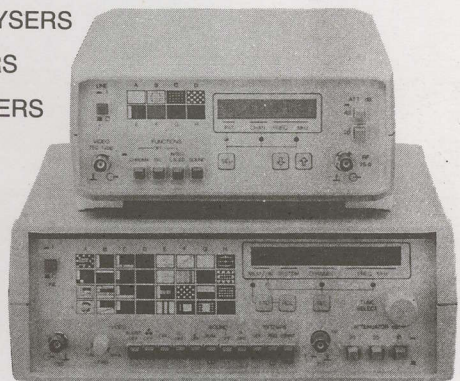

Freephone 0800-80-20-20

Freefax 0800-68-20-20

Email: sales@goughs.co.nz

TELARC
REGISTERED
SUPPLIER

CHRISTCHURCH
245 St Asaph Street
Christchurch, New Zealand
PO Box 22073
Fax 0-3-379 6776. Tel 0-3-379 8740

AUCKLAND
349 Great North Road
Auckland, New Zealand
PO Box 68150
Fax 0-9-378 4592, Tel 0-9-376 3174

WELLINGTON
1 Jackson Street, Petone
Wellington, New Zealand
PO Box 38421
Fax 0-4-568 4376, Tel 0-4-568 6675

GOUGH
TECHNOLOGY

Precisely!

UNIDEN SATELLITE TELEVISION

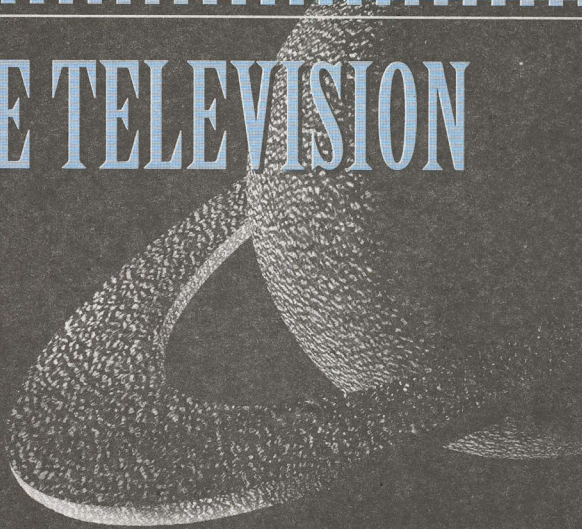

JUST IMAGINE...

Over thirty channels of free-to-air television from around the globe available throughout New Zealand, even in areas where present free-to-air or paid channels don't reach.

THIS IS NOT A DREAM, It's a reality. And it's available to your customers right now, with equipment costs that are probably a lot less than you would expect.



Uniden are about to launch their Satellite Television Package to dealers throughout New Zealand.

If you would like to find out how to profit from satellite television in New Zealand give Uniden a call.

After all, Uniden is one of the world leaders in satellite television technology.

UNIDEN SATELLITE TELEVISION

*Putting You Face To Face With
A World of Entertainment*

uniden®

a Clear Signal of What's Ahead

For more information Phone 0-9-273 8383 or Fax 0-9-274 0009

Uniden® is a registered trademark of the Uniden Corporation of Japan Ltd and is represented in New Zealand by Uniden (NZ) Ltd.