

15-10-96 0850AM

Bob Cooper's

OCTOBER 15 1996

# SatFACTS

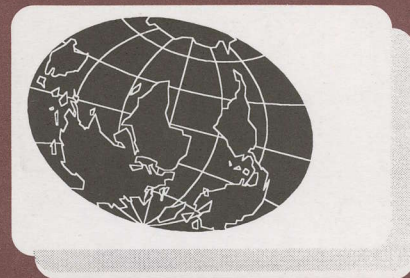

MONTHLY

Reporting on "The World" of satellite television in the Pacific Ocean Region

## IN THIS ISSUE

**STAR SE ASIA  
DIGITAL  
LAUNCH**

**OPTUS SAYS  
"B1/B3" are  
Stable!**

**MOTOR  
DRIVE  
BASICS**

- ✓ Latest Programmer News
- ✓ Latest Hardware News
- ✓ Latest SPACE Pacific Reports
- ✓ Cable TV Connection

**Vol. 3 ♦ No. 26**

Price Per Copy:  
NZ\$8/A\$9/US\$5

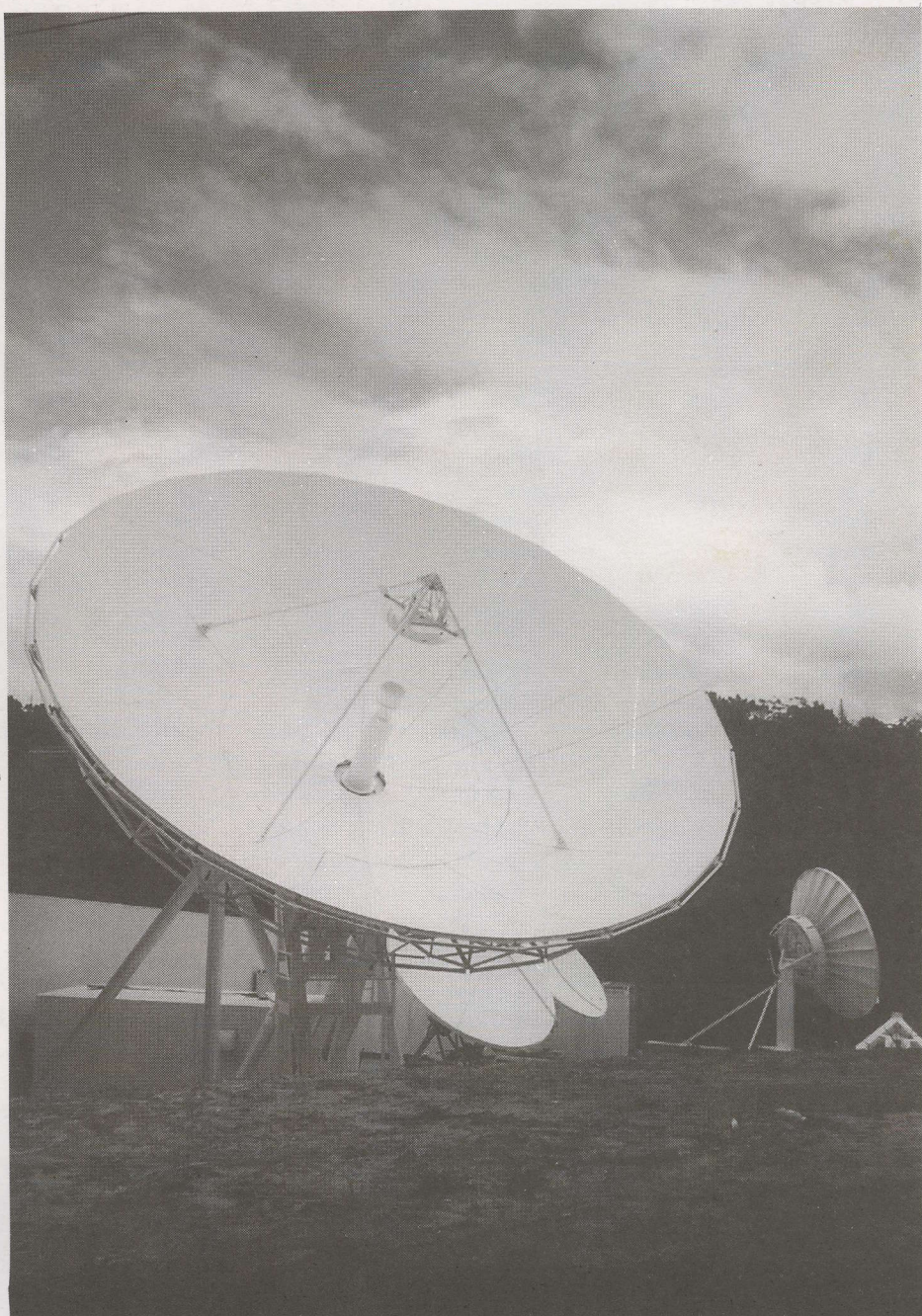

# Paraclipse<sup>®</sup>

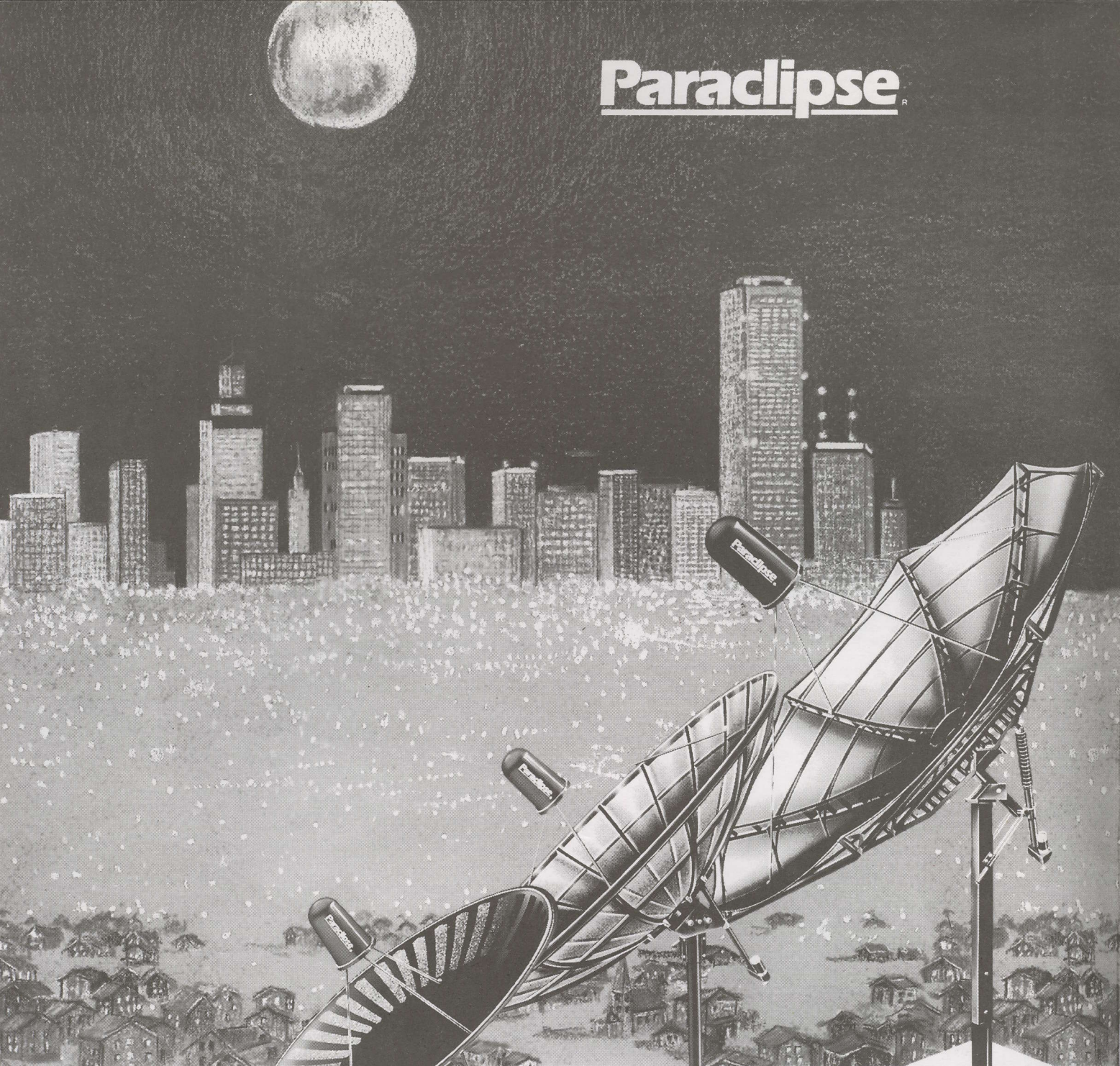

When quality, strength, and accuracy are your main requirements, **Paraclipse** antennas are your first choice.

Only **Paraclipse** offers such variety; four distinctly different series:

- the Truss-Ribbed Classic,
- the Courier Deliverable Eclipse,
- the Stretch Formed Hydro,
- the Commercial Patriot.

Every **Paraclipse** model sets the industry standard in its class, worldwide.



HYDRO  
SERIES

ECLIPSE  
SERIES

CLASSIC  
SERIES

Distributed in New Zealand by  
**Bay Satellite TV Ltd.** PO Box 14050 Hastings  
Tel: 64-6-878-9081 Fax: 64-6-878-5994

## Paraclipse<sup>®</sup>

HIGH PERFORMANCE ANTENNAS

Paraclipse Inc.  
2271 29th Avenue East, Columbus, Nebraska USA 68601  
Telephone: (402) 563-3625 FAX: (402) 564-2109

# SatFACTS

## MONTHLY

SatFACTS Monthly is published 12 times each year (on or about 15th of each month) by Far North Cablevision, Ltd. This publication is dedicated to the premise that as we enter the 21st century, ancient 20th century notions concerning borders and boundaries no longer define a person's horizon. In the air, all around you, are microwave signals carrying messages of entertainment, information and education. These messages are available to anyone willing to install the appropriate receiving equipment and, where applicable, pay a monthly or annual fee to receive the content of the messages in the privacy of their own home. Welcome to the 21st century - a world without borders, a world without boundaries.

**Editor/Publisher**  
**Robert B. Cooper**  
(ZL4AAA)  
**Office Manager**  
**Gay V. Cooper**  
(ZL1GG)

**Reaching SatFACTS**  
Tel: 64-9-406-0651  
Fax: 64-9-406-1083  
Mail: PO Box 330  
Mangonui, Far North  
New Zealand

**Subscription Rates**  
Within NZ: NZ\$40 p/y  
Australia: AV-COMM Pty  
Ltd, PO Box 225,  
Balgowlah NSW 2093  
61-2-9949-7417  
Elsewhere: US\$40 p/y

### ERRATA

SatFACTS Copyright 1996  
by Robert B. Cooper; any  
form of copying is a  
violation of our  
international copyrights.  
Advertising rate sheet  
available upon request.

## COOP'S COMMENT

When NBC Asia sent Peter Knight to SPRSCS '96 last January, it was a case of "Love at first sight." Knight, Director of Network Distribution, brought with him detailed material to explain the launch of their new NBC Asia service and package of CNBC + NBC Asia. He also brought with him two D9222 receivers; one went to Far North Cable TV Ltd, whom Knight acknowledged was the first cable affiliate in the South Pacific, while the second was used to demonstrate the NBC Asia service to attendees. Shortly after returning to Hong Kong, Knight's

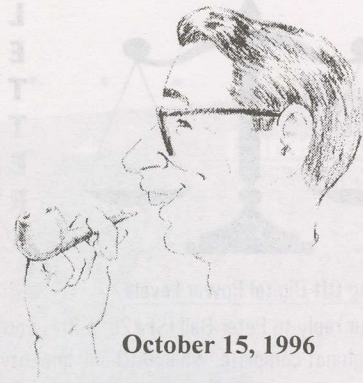

October 15, 1996



NBC's Knight at SPRSCS '96

staff began work on a marketing plan for New Zealand motels and hotels. They first offered free Pace DVR-500 IRDs to motels agreeing to take NBC + CNBC at a motel cost of US\$0.06 per occupied room per night. Thirty days later (now late May) the deal was changed: Free DVR-500s only to facilities with 100 rooms or more, but smaller motels could purchase their IRDs and still have the package of two channels at the same rate. Then 30 days later, the deal changed again (and by now Knight had left NBC Asia) with only CNBC on offer; NBC Asia was withdrawn because of reported "copyright problems."

For a brief period of time an aggressive, well executed sales group could have sold several hundred dish systems for NBC to New Zealand motels and hotels. Alas, before this

could get organised NBC changed the rules; with NBC Asia deleted, even with a free DVR-500, selling a dish plus modulator to a motel just for CNBC would be a hard sale.

By August NBC was making additional decisions affecting New Zealand. To be a cable affiliate for CNBC + NBC Asia the cable operator had to be willing to pay a minimum of US\$1,000 per month for the two services combined. At the cable rate of US\$0.60 per home per month for the combined services, this works out to 1,667 cable subs. Not impossible, but difficult to do the first day the cable system turns on. And for systems in rural communities, not possible. Ever.

NBC is hardly alone in changing the rules. Some of the more difficult "rules" to comprehend originate at Television New Zealand which refuses to allow cable firms legal contract access to BBC World in New Zealand; SKY which refuses access to ESPN and makes it difficult for TNT/Cartoons and others. I fear there are lawsuits on the horizon and the catch phrase during SPRSCS '97 may well become "Sue the bastards!"

### In Volume 3 ♦ Number 26

STAR South East Asia MPEG Bouquet -p.6  
OPTUS Says "B1/B3 Stable" -p.8  
Understanding Motor Drives -p.11  
MPEG DVB Compliant Update #6 -p. 16

### Departments

Programmer / Programming Update -p.2; Hardware / Equipment Update -p.4  
SPACE Notes: Hands On Training -p.20 ;  
The Cable Connection / Programming Access Challenges -p.22;  
SatFACTS Orbit Watch -p.24;  
With The Observers -p.26; MPEG-2 Tuning Parameters -p.27;  
September Reporting Form -p.30; SPRSCS '97 Reg Form -p.30

### -ON THE COVER-

13m monster dish installed and operational at first South Pacific privately operated uplink-for-hire, New Zealand Teleport Holdings Limited (Whangaraparoa). "Tiny" dishes in background are 5m!

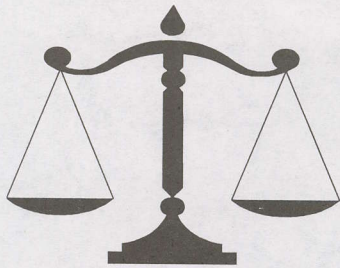

## LETTERS

### Backing Off Digital Power Levels

"Your reply to Peter Ball (SF#25, p.2) is correct although not complete. While IMD and linearity are a concern, you must also take into account the effect of symbol rate and FEC on threshold. The new Star Palapa C2M service (transponders 3EH, 5EH) for example operate with 26.85 Msym/sec and 7/8-rate QPSK. Threshold is at 4E-3 or very close to analogue TV/FM. Throw all of this together and put it into application and digital may not yield (as you correctly suggest) the lower thresholds that it could. This is what happens when marketing types make announcements concerning details they do not properly understand, leaving technical personnel looking stupid when the system fails to perform as the marketing types suggested it would!"

#### Engineer with Uplink Responsibilities

**Threshold as a function of Msym/sec and FEC rates are little understood by field users. An example of the backoff required might be the 2.25 kW TWT amplifiers at Star TV's AsiaSat-2 Hong Kong uplink; backed way off to ensure they remain "linear" with the MPEG loading.**

### Saw S-A Consumer IRDs

"During a meeting with Scientific-Atlanta in Toronto, I asked when or if a consumer IRD would be available for distribution. Their answer was, yes, there is in fact a consumer unit and they showed it to me connected and working. The unit is supposed to sell for approximately US\$1,000. The kicker is they told me the minimum order was for 100,000 units although they did recently complete a pilot run of 7,000. I told them I thought this is quite extreme. They recommended hardware distributors contact them directly; that being, Buddy Hill, Sales Manger, S-A at fax 770-903-6464".

#### Executive with a Programme Service

**SF has held back the names for the first two communicators out of concern that not everyone in their respective firms might appreciate their candid notes to us. We live in unsettling times.**

### If You Like DVB Compliant -

"I am working with Digital Audio Broadcasting - a radio medium as far as most people are concerned - which has been designed by public service broadcasters for public service broad-

-continued page 4-

## PROGRAMMER PROGRAMMING PROMOTION

## UPDATE

OCTOBER 15, 1996

RAI Uno will, when finally "hot" on EBB bouquet, be called RAI *International*. Delay in service start has many reasons including recent Italian elections, change in modus operandi for RAI and battles over copyright clearances for Asia and Pacific distribution of programming. Different feeds will evolve for various world segments from RAI. Contact is Giovanni Chelsi at tel 39-6-335-4256 and fax 39-6-331-71855. RAI International will be on programme channel 3 of EBB.

Canal France International (CFI) and TV5 are now closer in co-operation as well as sharing same building in Paris. CFI is evolving into export arm for French national terrestrial networks; TV5 is becoming programme creator for France export beyond terrestrial national services. CFI contact is Guy Muller at tel 33-1-40-62-32-32 and fax 33-1-40-62-32-62.

EBB fax-back "hotline" for Asia and Pacific: Fax Hong Kong 852-2504-3875 and push start (typically after 4th ring although it does not always work!).

RTVE, Spanish service within EBB bouquet, contact is Julio Ferrero at tel 34-1-581-5407 and fax 34-1-581-5412.

Malaysian MEASAT may now be transmitting 22 channel digital package (+ 8 radio programme channels) on Ku from 91.5E. The service is called Astro.

Japanese Perfect TV! (Ku on JCSat-3; 128E) continues to be plagued by software glitches; receivers scheduled for delivery late in September by Japanese suppliers were stopped at shipping dock, reopened and run back through the assembly line to make a modification in the software at request of service operator.

Second annual Australasian Cable and Satellite Conference is being held February 4-6 at Sydney Convention Centre, Darling Harbour. This year's event appears to be keying off of July 1997 anticipated deregulation of Australian satellite delivery rules and will deal with satellite, cable MMDS and narrowcasting. "Prime sponsor" for the event is General Instrument perhaps hoping to regain its market position after losing Galaxy supply contract with its Digicipher to Pace and Iredito one year ago. Note: Many European and North American visitors plan to attend SPRSCS '97 in Auckland (January 21-25), take a week holiday and then go to the Sydney show.

NBC Asia has come to India through partnership with Star TV using Star's digital bouquets appearing on C2M. For analysis of Star's digital bouquet, see p. 6 here.

Solar noise v. receiver recovery: During solar alignment (September) opportunity to check how well three different digital receivers handled encroachment of and recovery from solar noise. On European Bouquet, Panasat IRD520 was first to lose signal and last to recover; Pace DVR-500 was next and shortest loss was chalked up by NTL 3000. Time difference best to worst? NTL 3000 two minutes less outage than IRD 520 within 10 minute signal loss period.

Internet feeds via satellite could be huge business in Pacific during 1997. Hughes will launch two-way capable Ku band 'PC Direct' service through PAS-2 using NZ/Australia Ku beam; Deutsche Welle long promised MediaNet one-way Internet access is now rescheduled for 1 November launch within VBI (vertical blanking interval) of DW As2 signal. Analogue decoders should be available by December in Pacific through authorised distributors.

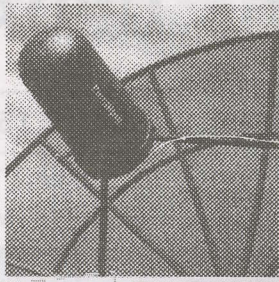

Paracclipse

Paracclipse  
full range  
down under!

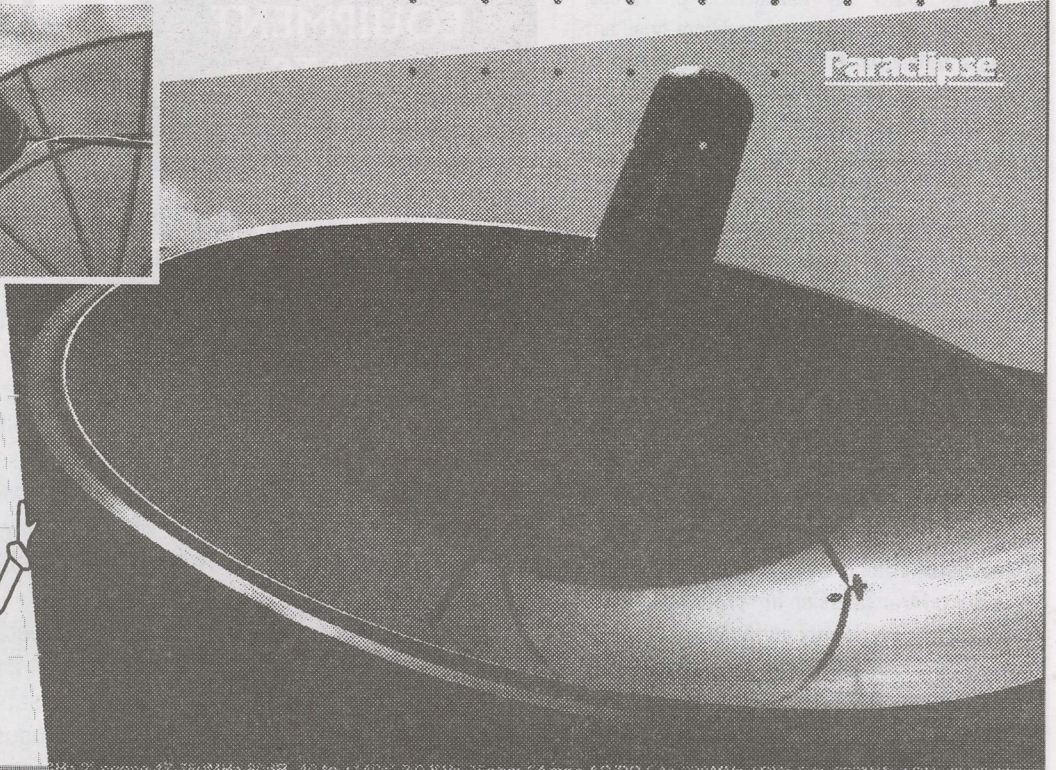
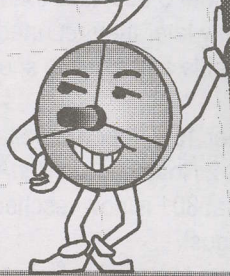

# Paracclipse Antennas

- High efficiency perfect reception
- Precision hydroformed and mesh antennas provide years of trouble-free reception
- Exceptionally distortion-free C and Ku band reception, even from 2° spaced satellites
- One piece hydroformed reflectors
- Heavy-gauge aluminum antenna adds structural strength
- Protected with a baked-on powder-coat finish
- Self-aligning, three pole feedhorn support
- A heavy duty, pre-assembled, fully adjustable polar mount

Available from:

**SKANDIA ELECTRONICS PTY. LTD.**



Head Office: 183 Burwood Road Hawthorn, Victoria, Australia 3122

Tel: (613) 9819 2466 Fax: (613) 9819 4281

NSW Office: 4/411 Church Street Nth Parramatta, NSW, Australia 2151

Tel: (612) 630 0888 Fax: (612) 630 8690



## STAR TV LAUNCHES DIGITAL SERVICE FROM C2M

The latest Murdoch empire regional MPEG digital programming bouquet began service on September 19th using two transponders on Palapa C2M at 113E. For most viewers south of the equator the service will have no immediate, direct impact on either their equipment choices or viewing habits as the services are presently located on the C2M "Asian beam" which has very poor coverage into most segments of Australia and even less signal for New Zealand and the South Pacific islands. Still, the services are illustrative of a growing trend to package target-specific programming services into multiplexes using digital techniques.

A Star TV memorandum dated late in July explains the "Star TV - Southeast Asia" package which is available to subscribers (cable, DTH, SMATV) in a number of target countries from India to Indonesia and beyond. The memorandum states:

"STAR TV (is launching) a network of new channels into South East Asia using the Palapa C2 satellite. Some channels will be new, others will be similar to those broadcasted on AsiaSat 1 in recent years. New digital MPEG2 technology will allow STAR to broadcast different language audio tracks or subtitles on any channel."

The AsiaSat 1 existing service is now considered "interim" by STAR which faces the challenge of converting existing free to air analogue viewers on AsiaSat 1 to some form of pay-to-view service on C2M. The memorandum notes:

"The AsiaSat 1 STAR TV Indian service will become increasingly less appealing to South East Asian viewers currently looking at STAR's free to air As1 channels."

The C2M service initially utilises a pair of transponders in the "(frequency) expanded" Asian beam of C2M. These transponders (3580/IF1570 and 3500/IF1650) are horizontal in polarisation and are on the same antenna beam pattern as CNBC/NBC Asia's "barker channel" FTA service (3620/IF1530).

The AsiaSat 1 "northern beam" will not be affected directly by what has happened or is happening with the southern beam. STAR characterises the northern beam as "difficult to receive in South East Asia ... and will only serve Taiwan." The AsiaSat 2 service is a special situation. Originally, STAR began tests of their variation of MPEG-2 in April (see SF#21, p. 2) on three vertical transponders: 3700 (IF1450), 3740 (IF1410) and 3900 (IF1250). Of these, 3700 was conditional access from

### PALAPA C2M STAR South East Asia (113E)

STAR Plus	General entertainment
STAR Sports	Live world, Asian sports
Channel [V]	English language
Channel [V]	Asian, Chinese music; Mandarin
STAR Movies	International & Western movies
Film Indonesia	Indonesian and Malaysian movies
Phoenix Chinese Ch.	Chinese general entertainment
Star Asian Movies	Chinese and Asian movies
NBC Super Channel	General entertainment
CNBC Asia	Financial News

### AsiaSat 1 STAR South East Asia (105.5E)

Zee Cinema	Indian movies, Hindi
------------	----------------------

This is the so-called Southern Beam for As1 where FTA analogue will be expanded for India to 7 programme channels of which only movies will be analogue encrypted. These include: STAR Sports (Cricket focused), STAR Movies (Bollywood version), India Channel [V], and Hindi language ZEE TV, EL TV and ZEE Cinema.

### AsiaSat 2 STAR South East Asia (100.3E)

SKY (London) News	24 hour news
VIVA Cinema	Advertising supported Filipino Tagalog movies

In fact, there are six video programme plus one audio programme channel on this bouquet (see p. 24) and how STAR will handle 'authorised disytribution' to only these two is unknown; see text.

## WHAT IT TAKES TO RECEIVE STAR SE ASIA

**Sufficient System Bandwidth:** Because these services operate below 3700 (MHz), the dish feed and LNB must be capable of working at least down to 3500. In some cases the feed will need to be replaced with an "expanded C-band" feed (good to 3400 MHz); in most cases the LNB will also need to be replaced with one rated from 3400 to 4200.

**Sufficient Signal:** This service operates with 'near analogue' grade digital parameters and requires more signal than the European Bouquet, NBC or PowerVu systems. Rule of thumb: The terminal must be able to produce CNBC from C2M 1 to 2 dB above threshold in at least a 22 MHz bandwidth (i.e., not with threshold extension) before the STAR TV SE Asia services will decode. After changing out (as required) feed and LNB, check the CNBC level. If it does not exceed threshold (no sparklies at 22 MHz bandwidth), don't even bother trying.

**Receiver Parameters:** The Pace built receivers are now available in limited quantities in Indonesia, will soon be in India and elsewhere. The model number can be the DVS211, DVS201 or DVS200. We are told but could not verify at press-time that pricing will be around A\$500-600. If that seems 'cheap', the price is being subsidised by STAR in hopes that receiver buyers will more than make up any temporary loss in receiver selling profit by becoming subscribers to the various programme channels on offer. The settings are Msym/sec 26.85, FEC 7/8 at a reported 3580/IF1570 and 3500/IF1650.

**Authorisation:** It is not entirely clear which programme channels will be available for subscription into specific markets. It appears all of the channels listed (page 6) will not be available in but a handful of countries because of copyright clearance problems. Australian users should find it possible using an Australian address to gain subscription to Channel [V] (both versions), possibly Film Indonesia.

**Programming Charges:** Not available to us at press-time.

This signal is an "indicator" of what you can expect from the SE Asia bouquet at any location.

the beginning, and 3740 joined the CA family in June. The 3900 bouquet is primarily used to feed STAR Plus programming to Japanese cable systems although as the table on page 6 here indicates, it also carries Sky News (London) and Filipino targeted VIVA Cinema. About the AsiaSat 2 programming, STAR advises, "AsiaSat 2 will not carry STAR TV programming or channels relevant to the majority of South East Asian viewers."

Cable TV and SMATV system use will depend upon the location of the system and Star's ability to gain copyright clearances. Star is lukewarm concerning the probability that Star Plus, Star Sports, Star Movies can be cleared for either Australia or New Zealand (but says they are working on this although admitting, "We have not considered copyright clearance for Australia nor New Zealand up to this time"). They claim Sky News and VIVA Cinema from As2 can be cleared for cable in a wider area including New Zealand.

Star also says that "Most of STAR TV's channels on Palapa C2 SE Asian service will not be the same as STAR channels seen on As1." As noted, STAR appears to be planning a programming redesign to convert most Indian cable systems to the AsiaSat 1 feed, and most other viewers to the Palapa C2M feed. With AsiaSat 3 due into operation in second half of 1997 (122E), and S-band satellite Indostar due now in first half of 1997 (106.3E), none of the C2M STAR TV transponder assignments should be taken as being permanent. Star itself claims they will expand the present SE Asia service package to "at least 20 programme channels" within the coming year. At the same time, Star is committed to providing a 100 programme channel bouquet into Japan within 18 months and there is a companion serious business plan to provide a bouquet for (mainland) China as well. What we can be certain about is that within 18 months, the transponders that now interest us will be of minor importance in the ever enlarging scheme of programming bouquets yet to be brought on line.

Early reception tests in portions of Australia indicate that at least some areas will have sufficient signal to make the new SE Asia bouquet receivers play properly (see "What It Takes to Receive," this page). As with any new service, SatFACTS invites reports from the field with particular interest in reports of areas where CNBC is at or above threshold on Palapa C2M at this time.

Star Plus	Star Sports	Channel [V] Asia	Channel [V] Intern.	Star Movies	Film Indonesia	Phoenix Chinese	Star Asian Movies	NBC Super Channel	CNBC
English	English, Bahasa	Mandarin	English	English	Bahasa, Malaysian	Mandarin	Mandarin	English	English
no subtitles	no subtitles	no subtitles	no subtitles	Bahasa subtitles	no subtitles	some Bahasa	Bahasa, traditional Chinese	no subtitles	no subtitles

## OUR ORBIT IS NOT INCLINED!

SatFACTS #25, within the Letters segment, included a report from satellite system installer Les Brooks (Alice Springs) concerning his difficulties with achieving reliable reception from Optus B3, Galaxy service. Central Australia is outside of the normal Galaxy coverage region and we all accept that when you are attempting to create reception in a nominally non-served region there will be problems.

Brooks observes, "(Galaxy) still drops out twice per day when B3's unpublished inclined orbit reaches the extremes of the figure 8." And SF responded, "NASA tracking advises B3 is moving 0.1 degree E and W but only 0.02 degrees north and south of equatorial spot. None of this is enough to explain the outages Les reports nor that New Zealand observers routinely see." In other words, while Les may have felt the outages were created by an inclined orbit for B3, NASA data clearly shows the movement of the satellite is very small and certainly not sufficient to create an "inclined orbit" effect for a dish fixed at the nominal geostationary orbit spot.

Duncan Henry, Manager of Satellite Operations for Optus Communications Pty Ltd has responded to the report. Apparently Duncan understood only Les Brook's allegations of an inclined orbit and not our response which quite properly should have ended the "inclined orbit" theory. Henry writes, "It is a mystery where some of this stuff comes from, but somewhat alarming to see it published."

He continues, "B1 and B3 are both maintained within a specified station keeping box of plus or minus 0.05 degrees in latitude and longitude around their nominal position (160E, 15E respectively). Here is a plot showing B3 lat/long over a complete station keeping cycle (2 weeks). The actual azimuth/elevation variation for an antenna is magnified (an antenna on the surface of the earth is closer to the satellite than the centre of the earth, plus/minus 0.05 degree is a measurement from earth centre). The magnification factor is dependent on the location of the earth station, and the second plot here shows the az/el variation from a New Zealand earth station.

"It should be noted that the high-performance beam is not designed to cover either NZ or Central Australia, so any reception there at all is fortuitous. The daily variations seen there are not surprising and could be due to a number of factors, including changes in the earth station performance as a function of temperature,

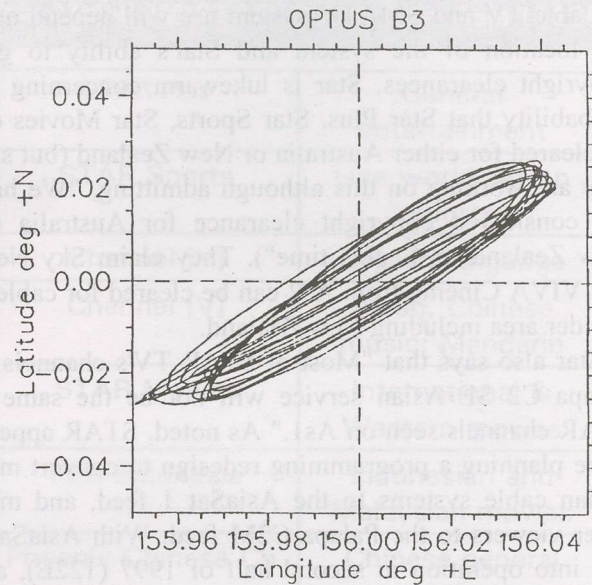

OPTUS B3 2 week stationkeeping cycle (not dated) shows satellite maintains 0.06 x 0.03 at extremes

daily temperature cycles on the satellite and orbit perturbations."

We trust this will end allegations that Optus is inclined but point out that eliminating satellite inclination only makes the challenge of explaining the twice-daily outages more difficult. We believe Optus is well aware of the reason for these outages and the reason has nothing to do with "fortuitous" reception rationale. Perhaps someday they will share this information.

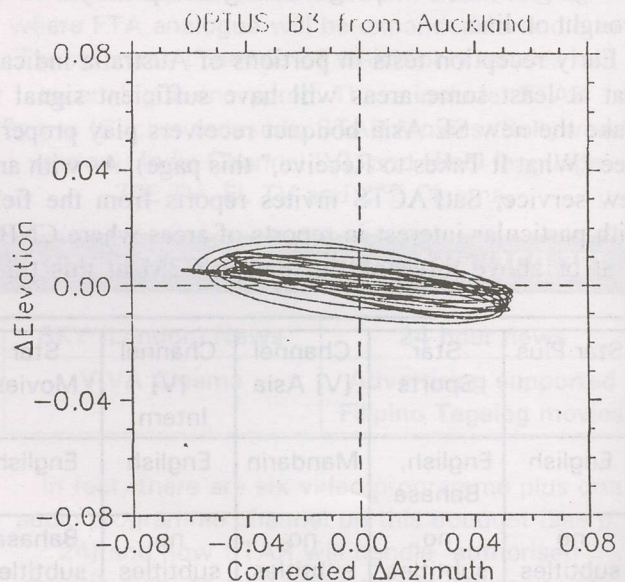

Where you are makes a difference in how satellite movement appears; here, for Auckland and B3



# PANORAMIC SATELLITE METRE

## MC10-SAT

AU\$1599 (TAX-EX)

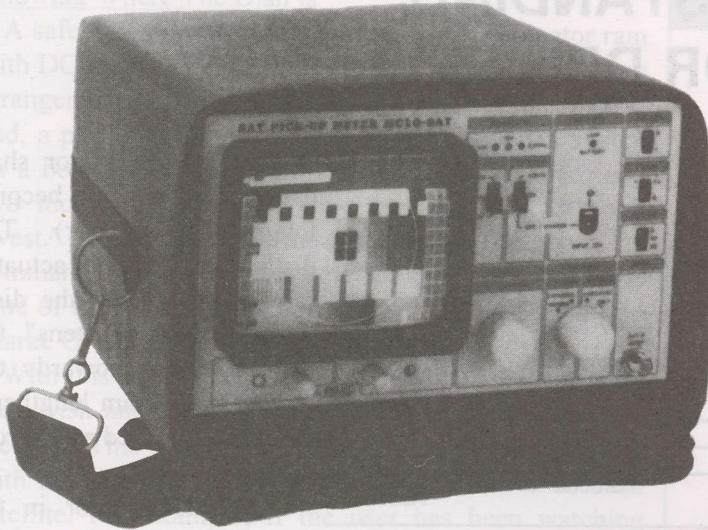

A PERIFELEC  
PRODUCT

- SATELLITE POINTER AND FIELD INDICATOR WITH RECEPTION ON 14cm (5.5") SCREEN
- FREQUENCIES FROM 950 TO 2150 MHZ
- DISPLAY OF FULL-BAND AND EXPANDED SPECTRUMS ANALYSER
- DISPLAY OF PICTURE OF SELECTED CHANNEL
- POSITIVE (Ku Band) AND NEGATIVE (C Band) VIDEO DEMODULATION
- MEASUREMENT OF SIGNAL RECEPTION STRENGTH BY WHITE BAR SUPERIMPOSED ON THE PICTURE AND PROPORTIONAL IN LENGTH TO THE SIGNAL IN STRENGTH
- RANGE OF MEASUREMENT OF SIGNAL STRENGTH BY WHITE BAR SUPERIMPOSED ON THE PICTURE AND PROPORTIONAL IN LENGTH TO THE SIGNAL STRENGTH
- RANGE OF MEASUREMENT OF SIGNAL STRENGTH FROM 50 TO 90 dB $\mu$ V
- POWER SUPPLY TO LNB IN 14 OR 18 VOLTS AND 22 KHz
- BATTERY LIFE : ABOUT 1 HOUR
- WEIGHT : 5.1Kg

THE MC10-SAT SATELLITE FIELD STRENGTH METER IS NOW CONSIDERED AS THE ESSENTIAL TOOL FOR ADJUSTING SATELLITE RECEPTION DISHES. THE VISUALISATION OF THE SPECTRUM AND THE PICTURE ALLOWS THE CARRYING OUT OF ALL THE NECESSARY ADJUSTMENTS WITH THIS ONE INSTRUMENT.

**FREQUENCY RANGE :** from 950 to 2150 MHz  
**TUNING:** Multiturn potentiometer  
**INPUT IMPEDANCE :** 75 Ohms  
**INPUT CONNECTOR :** F-TYPE  
**INPUT ATTENUATOR :** 0.10 & 20 dB USING 3 POSITION SWITCH

**SIGNAL STRENGTH :**

- **INDICATION :** by a white bar superimposed on the picture, its length being proportional to the strength of the received signal, and also by audio indicator
- **READING :** on the scale from 0 to 70 dB $\mu$ V
- **MEASUREMENT RANGE :** from 50 to 90 dB $\mu$ V

**LNB POWER SUPPLY :** 14 or 18 V and 22 KHz by switch

**DISPLAY ON 5.5" CATHODE TUBE**

**- SPECTRUM :**

- Full band spectrum (FROM 950 TO 2150 MHz)

- Expanded Spectrum with visualisation of the counter-polarisations

**- PICTURE :**

- positive video polarity (Ku Band) or negative video polarity (C Band)
- Picture of selected channel only
- Picture of selected channel with signal strength indication

**POWER SUPPLY :** 12V, 3 AH battery

**CONSUMPTION :** 1.2 A (without LNB)

**BATTERY LIFE :** about 1 hour

**CHARGING TIME :** about 4 hours

**DIMENSIONS :** 240 x 140 x 270mm

**WEIGHT :** 5.1Kg

**ACCESSORIES INCLUDED :** Measurement cord, AC mains adaptor, charging lead for car cigar-lighter, case.

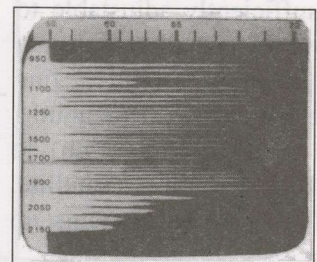

FULL BAND SPECTRUM

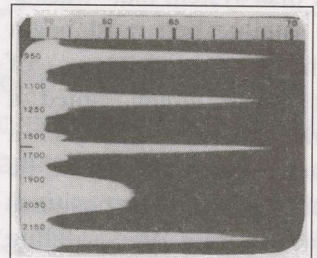

EXPANDED SPECTRUM



DEMODULATED PICTURE



PICTURE + MEASUREMENT



TEL 61-2-584 1233 FAX 61-2-584 1452

99-105 BOUNDARY ROAD, PEAKHURST NSW 2210 AUSTRALIA

## UNDERSTANDING MOTOR DRIVES

Satellite dish systems fall into two general categories: Those that move from satellite to satellite, and, those that are fixed on a single satellite. In a fixed mount system it is only necessary for the mount to be sufficiently adjustable to allow the installer to locate the desired satellite, fine tune the east-west (azimuth) and up-down (elevation) to peak the dish on the satellite, and lock all adjustments up tight.

A dish system that "tracks" the satellite belt must begin with a special type of mechanical mount called a "polar mount" (PM). Such a system allows the dish to be (from a remote position) moved across the satellite belt as this arc (the Clarke

Orbit Belt) appears above the equator. The orbit belt scribes a semi circle in the sky which from any specific location is highest (maximum elevation) for a satellite due north (south) of that location. The arc tapers downward (towards the earth) to the east and west of maximum elevation and disappears beyond the horizon to your west-northwest (south-west if north of the equator) and east-northeast (south-east if north of the equator). The polar mount has been designed to "follow" the satellite arc, if properly installed. A dish installed on a polar mount will, then, "track" or follow the Clarke Orbit Belt semicircle if pushed or pulled by a mechanical arm.

The actuator is such an arm. This is a ram-screw motor driven device with power for the motor originating at a dish controller or from within the receiver. The motor voltage is DC (Direct Current), typically in the 24-36 volt range. The ram screw is rated in tons (or parts of a ton) lift. As the voltage is turned on the ram screw motor rotates a shaft which drives a gear train. This gear train is coupled to a mating set of gears attached to the ram 'tube' inside of a protective metal tubular cover. The

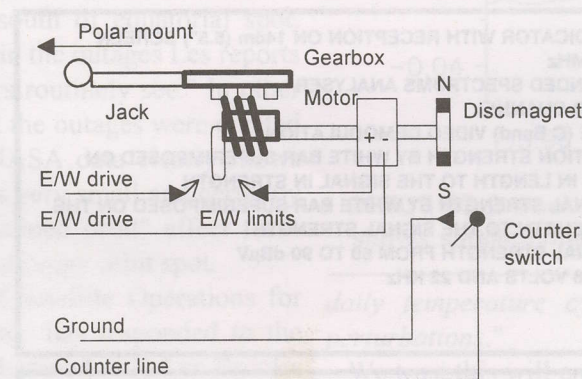
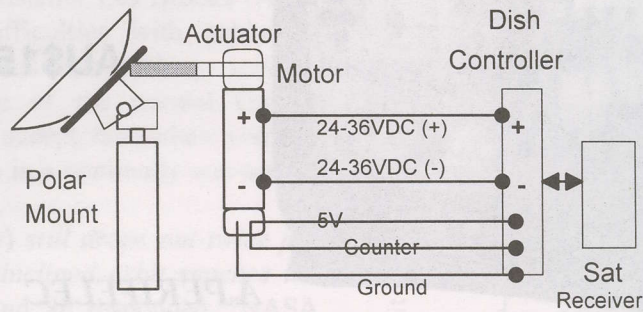

rotation of the motor shaft causes the ram to become longer (or shorter). The distant end of the actuator ram is attached to the dish. As the ram "shortens" the dish is pulled towards the motor; as the ram lengthens, the dish is pushed away from the motor.

The DC motor in the actuator unit has a positive (voltage) and a negative (voltage) terminal. If, at the dish controller / receiver the polarity of the DC is reversed, the motor also reverses in direction. In this way the user can push or pull the ram by simply reversing the polarity of the motor voltage; the ram goes in, the ram goes out, on command.

A simplistic system consists of the motor driven

ram, a voltage supply and some method of reversing the polarity of the DC. Consider, however, what might happen if the user holds the motor operate switch to the point where the ram is fully extended (or fully retracted). And keeps holding the switch closed. At this point the ram motor continues to try to turn but the ram will go no further. There are several possibilities as to what happens next:

- 1) The motor overheats, and a fuse blows.
- 2) The motor is not fuse protected and the power supply for the ram motor overheats and faults.
- 3) The ram motor shaft continues turning, driving the actuator off the end leaving two dangling, broken pieces at the antenna.
- 4) All of the above.

To protect the ram motor, the power supply, and the dish system from misadventure, a pair of mechanical "switches" are included inside of the ram (exterior on some installations). These "limit set switches" are typically adjusted by the installer at the time of dish installation. They ensure that even if someone holds the "dish mover button" down (closed) beyond a safe point of ram operation, the DC to the motor is "broken" to prevent the motor from driving the ram too far in (or

out). Think of the limit switches as "safety nets" to prevent misuse of the ram.

### Knowing Where The Dish Is

A safe, but still simplistic system has the actuator ram with DC motor, an DC supply for the motor, a switching arrangement to select polarity reversal for the motor, and, a pair of limit switches. The controller is a switch on a box that has a "neutral" (motor off) position, and two more positions marked appropriately "east" and "west." Remember that the dish moves east/west on command; the north/south (elevation) is pre-set at the time of installation as a part of the dish installation and Clarke Orbit Belt tracking procedure.

With this system the user can push "east" or "west" as they wish and the dish will move accordingly through the belt. This requires the user be reasonably familiar with the satellites, and the transponders active on each satellite. For example, if the user has been watching CNN on PAS-2, he begins with the receiver adjusted to (a) horizontal polarisation, and, (b) IF1183 MHz. Before he begins moving the dish to locate EM TV on Gorizont R42 at 142.5E he must adjust the receiver to an IF of 1265. Why? Because once the dish ram is activated towards 142.5E, the only way the user will know the dish has found this satellite is to have the receiver pre-tuned to the correct frequency for EM TV.

In a multiple satellite universe with variations in polarisation (left hand or right hand circular, linear vertical, linear horizontal) the user must either be a fast learner with a retentive memory, or work from a "cheat sheet" supply by the installer. Or, the entire system could be automated with a microprocessor.

When the actuator is functional (voltage applied) a multi-wire cable sends a stream of voltage pulses indoors to the controller. The pulses can be created in a number of ways; one of the more popular approaches is to install a small magnet on the end of the motor shaft (1). The magnet has a "north" and "south" pole and as the motor shaft rotates, the magnet passing near to a reed switch causes the switch to "pulse" (open/close) twice for each shaft revolution.

The pulses enter the controller and each pulse is sent to a register. If the dish has been initially set up with due north (or south) at a receiver-unique register count of 000, then any number greater than 000 suggests a location for the dish other than due north (south). For the southern hemisphere, if the installer moves the dish to due north and using the remote control enters due north as 'count 000,' and then moves the actuator under manual control until the dish is pointing at PAS-2, the counter will register a new number. Call it 090 for now.

1/ The magnet + reed switch is one technique to generate pulses. Another uses an optical-mechanical system with an LED, a rotating plastic disc with two holes in it, and a photodiode. See illustration, p.12

SPRSCS '97

TELEVISION RECEPTION  
MADE  
SIMPLE

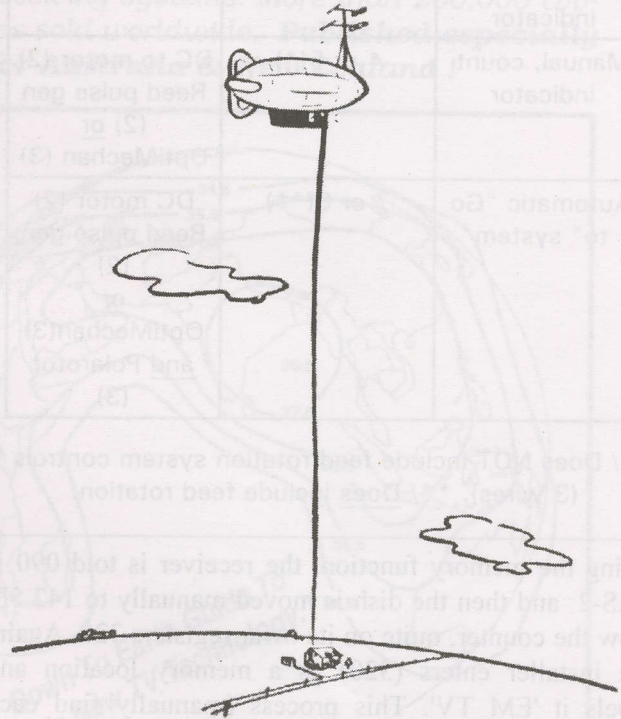

Some people will go to immense effort to create better TV reception, or more varied programming.

There is a far simpler answer made possible by modern technology. Satellite is the name of the newest game in TV reception. And Auckland (NZ) is the place to be January 21 - 25 for the annual South Pacific Region Satellite & Cable Show!

Explore the world of MPEG digital TV, Internet via satellite, cable TV and SMATV systems made possible by the more than 50 new-in-1997 TV programming channels scheduled to come into operation during the new year.

SPRSCS '97 is the largest gathering of hands-on technical and management personnel in the Pacific each year. In 1996, 18 countries were represented. PLUS - the region's most complete "antenna lot" with approximately 30 operating dishes functional!

- ✓ Lecture and laboratory training sessions
- ✓ Prominent technology leaders from Europe, North America, Asia and the Pacific as teachers
- ✓ Instructional courses leading to certificates on offer

Full brochure: tel 64-9-406-0651, fax 64-9-406-1083

## Wiring Requirements for Motorised Systems

Type of Control	Number of wires	Wires to ...
Manual, no indicator	2(*)	DC to motor (2)
Manual, count indicator	4 or 5(*)	DC to motor (2) Reed pulse gen (2) <u>or</u> OptiMechan (3)
Automatic "Go to" system	7 or 8(**)	DC motor (2) Reed pulse gen (2) <u>or</u> OptiMechan(3) <u>and</u> Polarotor (3)

\*/ Does NOT include feed rotation system controls. (3 wires). \*\*/ Does include feed rotation.

Using the memory function, the receiver is told 090 is PAS-2 and then the dish is moved manually to 142.5E. Now the counter, quite on its own, registers 320. Again, the installer enters (320) as a memory location and labels it 'EM TV'. This process (manually find each satellite, tell the controller [receiver] to memorise the count for each location where there is a satellite) is repeated until the full arc has been covered. If the eastern most satellite from your location is found at 000 and the western most at 950, then the balance must be at some number between these two extremes.

An actuator with a DC power supply and an "east/west" switch is the most basic form of remote dish control. The next step is to place a counter device at the dish, connected to the actuator motor shaft, to generate pulses which in turn operate a display system inside. This allows the user to at least know (by the display on the counter) where the dish is located at any instant. Once you have a pulse generator at the actuator and a display inside, the next level of technology is to

Optical-mechanical pulse system uses LED as light source and photodiode as detector. Two holes in rotating disc create twin pulses per full rotation when LED light passes to photodiode optical

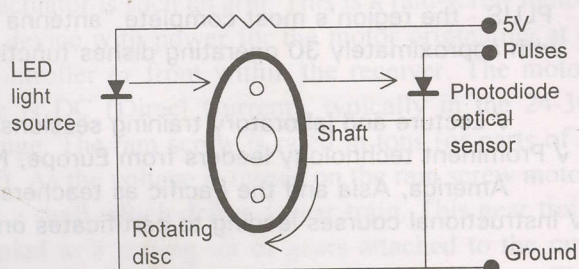

"register" the count in a form of electronic memory. If the controller can be told that a specific register count is equal to a specific satellite (location), and the controller has a keypad controller to allow the user to enter specific locations (either by count or by satellite name), we now have the ingredients of an automated system.

### Common Faults

Problems fall into two categories: Mechanical, and electrical. Mechanical problems are beyond the scope of this report. Electrical problems subdivide into:

- 1) Poor wire choices
- 2) Non weather tight connections.

The actuator motor can draw a couple of amperes current which means motor voltage runs longer than 50 metres should never be done with wire sizes smaller than no. 14 equivalents. Too small wire causes excessive voltage drop (loss) resulting in an inadequate voltage at the actuator. This problem is apparent when the dish is at a low look angle (such as to As2 from New Zealand or Express 2 from Australia) and the motor huffs and puffs (runs slowly) when trying to return to a higher look angle.

The wiring for the pulse run is very prone to picking up interference from household appliances, electrical fence controllers, just about anything that "pulses" in performing a function. The pulse run should be in well shielded wire (two or three plus a shield around the set). If interference gets into the pulse line, the counter (sensor) at the controller (receiver) sees the interference as additional (false) pulse counts. This causes the counter to mis-total and if your "normal" display number is off by several (or several dozen) without explanation, this is the most common reason why the counter has gone screwy. Wire size for either the pulse counting system or the polarisation control is relatively unimportant as long as the total run lengths do not exceed 100 metres.

Corrosion of connections is another serious threat to long term operation. Some wire ends supplied with devices such as polarisation rotating units are aluminium or even clad steel. Chances are your wire that connects to such devices and then runs inside will be more copper (at least copper clad or coated). And when you join the wire you supply to the pigtail leads with the product, you now have the basis for a battery: Two dissimilar metals in a moist environment. Galvanic action will start immediately! All connections should be sealed in a two-step process:

- 1) Wrap the connection after soldering or using wire joiners with outdoor rated electrical tape (most bargain priced hardware store tape is not rated for outdoor use), and,
- 2) Using self-curing sealant or caulking compound, envelope the taped connections with a generous glob of protection.

**1996  
EIGHTH EDITION**  
covering Australia, New Zealand  
and the South Pacific



Introducing a Newly Revised & Expanded Edition of the world's best selling satellite TV technical handbook on buying, installing, operating and maintaining home satellite TV receiving systems. More than 200,000 copies sold worldwide. **Published especially for Australia & New Zealand!**

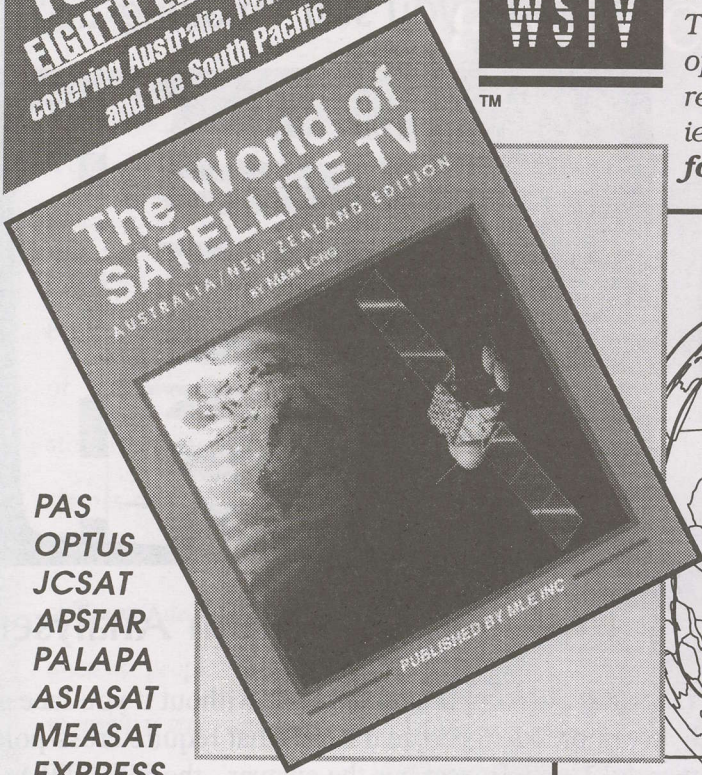

- PAS
- OPTUS
- JCSAT
- APSTAR
- PALAPA
- ASIASAT
- MEASAT
- EXPRESS
- INTELSAT
- THAICOM
- STATSIONAR, ETC...

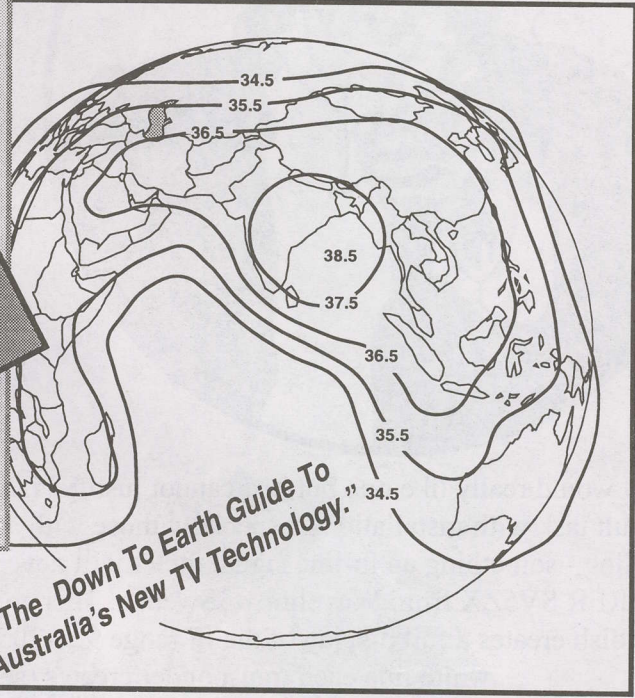

*"The Down To Earth Guide To Australia's New TV Technology."*

**F**eaturing all-new descriptions of the existing and future domestic, regional, and international satellites serving Australia, New Zealand and the South Pacific. **The World of Satellite TV** (WSTV) presents the very latest direct-to-home (DTH) satellite TV receivers and IRDs, feedhorns, antennas and LNBS, as well as presentations covering signal encryption and MPEG-2 digital video compression. Also featured are step-by-step instructions on how to install, operate, maintain and repair DTH systems—including the use of satellite test equipment—and overviews of MMDS and SMATV distribution systems. Jam packed with more than 70 photos, 75 technical charts and graphs, 50 new satellite coverage maps, and a 17-page section covering the available satellite TV program services. **The World of Satellite TV** includes 216 pages perfect bound in a 247x186mm format, printed without advertising!

**Ordering Information:** WSTV—Australian & New Zealand Edition is now available for A\$29.90 plus A\$5. for Express Post to anywhere in Australia, or A\$15. for Air Mail dispatch to New Zealand and the South Pacific. We accept Bankcard/Visa/Mastercard.



**AUSTRALIAN &  
NEW ZEALAND  
EDITION**

**Peter C. Lacey Services Pty. Ltd.**  
80 Dandenong Rd., Frankston, VIC 3199 AUSTRALIA  
Tel: (03) 9783 2388 Fax: +61 3 9783 5767  
e-mail: placey@netlink.com.au

Name ..... Address .....

City ..... Postcode ..... Phone .....

Bc/Visa/Mc no. .... Expires ...../...../..... Signed .....



## UNCLE BAYSAT ASKS ...

Are you still "making do"

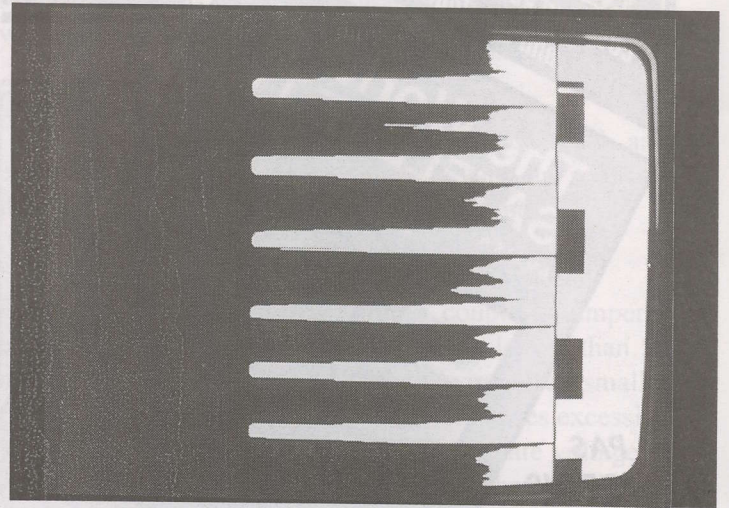

without a Spectrum Analyser?

YOU would really like one but just cannot justify NZ\$5,000 plus. On the other hand, without it you face a difficult task with installations, especially those with an orthomode feed (dual LNB) that require cross-pole nulling - something an in-line signal meter will never do! Uncle Baysat has the answer - the SPECTRA EXPLORER SV5ZX from Waveline of Sweden. This unit, when connected to a standard TV set and the IF feed from the dish creates a full display of the IF range 920-2050 MHz. Signal strength is indicated by the length of the white line each transponder creates (see photo above from C2, horizontal).

This unit is so sensitive it will display signals just above the noise floor - below P1 on even the best satellite receiver. Cross pole nulling an orthomode is a breeze with the Spectra Explorer SV5ZX. You have a visual screen reference of declining (or increasing) transponder strength, just as you would on a Spectrum Analyser costing thousands more. The perfect tool for professional installs at a price that will make your bank manager smile!

only  
**NZ\$450**  
plus GST and  
freight

- ▶ Right hand vertical stripe indicates band segments (frequency)
- ▶ Mode 1 switches between spectrum display and satellite reception; Mode 2 is spectrum display only.
- ▶ Zoom switch to display only single transponder, rotary dial selects transponder to 'zoom'
- ▶ DX position for very weak signals buried in the noise, narrow band low level carriers

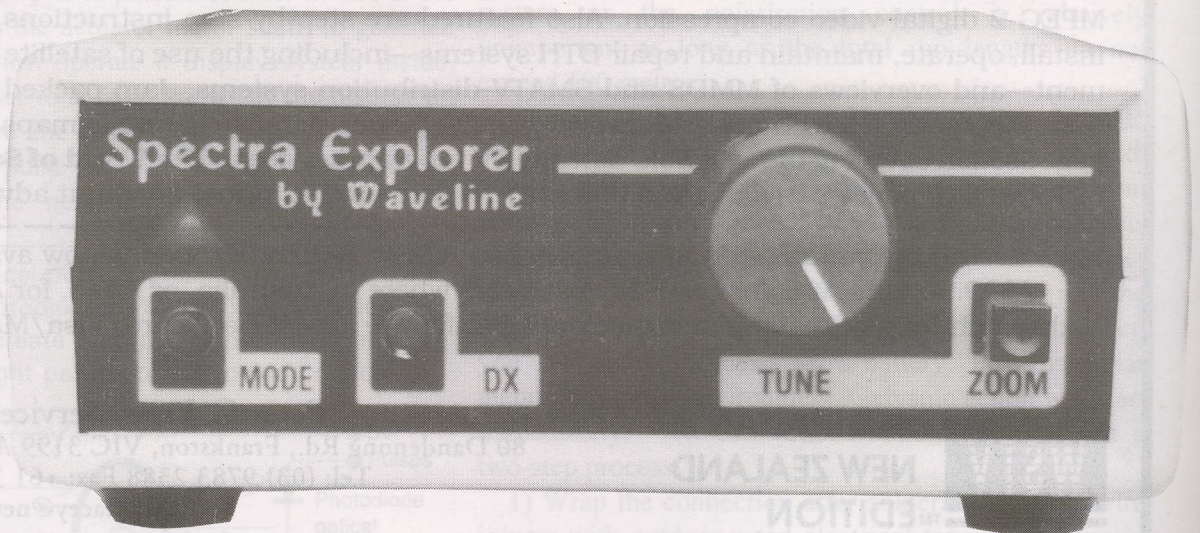

## BAY SATELLITE TV LTD

**YES!**

We accept VISA, Mastercard  
with no surcharge!

SatFACTS October 1996 ♦ page 14

PO BOX 14050 • Hastings • New Zealand • Tel toll free 0800 BAYSAT  
International 64-6-878-9081 • Fax 64-6-878-5994 (0800 - 229 - 728)  
e-mail john@baysat.co.nz WWW <http://www.earthlight.co.nz/baysat>

## SL-8000RP

4500 years ago, the Egyptians were so far advanced in building technology that the pyramids were considered to be one of the Seven Wonders of the World. Today, still standing, these magnificent shrines to the achievements of man leave us marvelling at the skill and dedication of these ancient people. Fine craftsmanship is truly an ageless art.

Palcom receivers reflect skills and craftsmanship based on the same traditional values. The flagship of the Palcom range, the SL-8000RP is another marvel of technology.

## From BC2500 to SL-8000RP

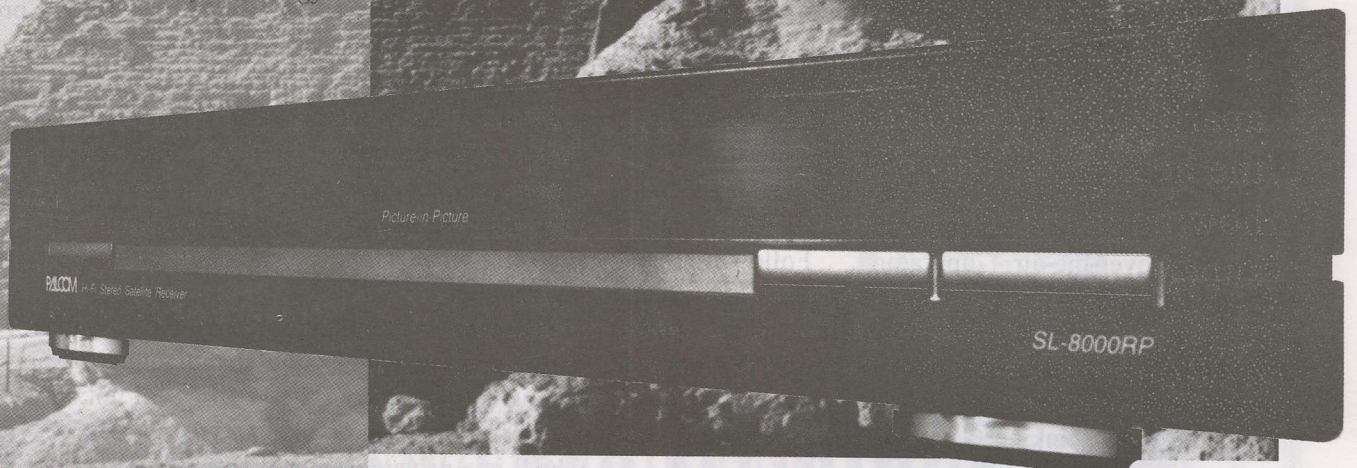

Its unique moving Picture-in-Picture feature permits the viewing of two channels at the same time (on one TV or two) or watching one channel whilst recording another. Mix images from satellite and terrestrial TV, satellite TV with VCR playback or satellite TV and security camera output with a choice of picture size for each image source.

The weakest signals may be viewed using the Palcom low threshold tuning facility producing improved video and audio performance.

A built-in antenna positioner provides access to all current satellites

500 Channels • 2 Tuners • 3 IF Inputs • Weak signal Video and Audio processing • HiFi 1600 • Stereo Audio processing (sterround) • On Screen Display in 6 languages • Channel Naming • Satellite Naming • LNB Naming • Decoder Naming • 16 Local Oscillator presets (adjustable) • 22kHz Tone Switching • Global and Fine Ferro/Skew adjustment • Alphanumeric Channel List • Favourite Channel Function • 16 Preset External Decoder configurations • Internal VideoCrypt ready • Timer / Priority switching for TV and VCR

with software by....

# PALCOM

State of the Art Simplicity

## MPEG-2 DVB COMPLIANT UPDATE NUMBER SIX

The European Bouquet, faced with the distressing news that no prominent or even unknown receiver manufacturers are coming to their rescue with DVB Compliant product for sale in Asia and the Pacific, met in Italy just as this report was being prepared to consider proposals from four European receiver manufacturers. The group was hoping to find some way to encourage production of a minimum of 5,000 DVB Compliant MPEG-2 format receivers which in turn would begin the process of equipping interested viewers with the equipment necessary to warrant continued operation of the European Bouquet. Some history.

Deutsche Welle took the lead with AsiaSat to lease a full 36 MHz C-band transponder on As2. DW convinced fellow 'public broadcasters' TV5, MCM (both France), Rai (Italy) and RTVE (Spain) plus numerous public radio broadcasters to join them on this transponder. The service was named 'The European Bouquet'. First operation began this past April with DW and TV5 present. The others (less RAI which is still promising to start) have joined the Bouquet subsequent to April.

The first 45 days of transmissions proved that only viewers with the relatively expensive NTL 3000 mode receivers could decode the MPEG service. This was bothersome since DW had intended that any "standard" MPEG-2 DVB Compliant receiver would be capable of receiving all of the programming from the bouquet. There was to be no conditional access, no charge for viewing. Early in June the NTL built uplink was modified and suddenly a range of receivers, including the Pace DGT-400 distributed by Galaxy pay TV Australia could tune-in the transmissions. Immediately interest in receiving the bouquet mushroomed.

By mid-July Galaxy was sending new addressing instructions to their universe of DGT-400 receivers through over-the-air upgrading. Following this procedure, DGT-400s so upgraded would no longer receive the bouquet services. When it became apparent that Galaxy was upgrading their IRDs and this upgrade destroyed the usefulness of the unit for reception of the bouquet, quick thinking Galaxy users immediately took

steps to protect their IRDs from being upgraded. Sadly, many hundreds of Galaxy + C-band equipped homes in Australia were not quick enough to save their bouquet reception. Galaxy, of course, maintains the upgrading was for a business purpose of their own and was in no way connected to use of their receivers by C-band bouquet watchers.

Outside of the NTL 3000 and the Pace built DGT-400 for Galaxy, there have been two receivers which have proven to be capable of reliable reception of the bouquet. One is the Pace DVR-500, a receiver originally designed for use by MultiChoice in South Africa but distributed in very small numbers to motels, hotels and cable systems in the Pacific and Asia by NBC Asia for its PanAmSat (PAS-2) digital transmissions. That the DVR-500 would function with the bouquet was more academic than real since through early October this receiver could not be purchased in the Pacific and was only available through NBC Asia for its affiliates (who in turn were to use it with the NBC Asia services). Just as SF goes to press, Bay Satellite (1) has received a shipment of the DVR-500 receivers from South Africa with a promise of more in transit.

The Panasat IRD520, also originally built for the South African MultiChoice service market, has been available in the Pacific since late in June (2). This receiver seemed "temperamental" at first, as we reported, but the industry now better understands how to install it properly to eliminate the initial problems reported (3). Still, like the DVR-500, it was designed for a totally different application (Ku at that) and even without its early temperamental problems, it is not a designed-for-European bouquet (and other free to air) digital services. Virtually every issue of SF since last May has contained reports that numerous other receiver suppliers were "close" to releasing suitable receivers for the bouquet.

The precise format adopted by the European Bouquet partners to jump-start the manufacture of appropriate receivers for Asia and the Pacific will not be announced until after this issue is into the mails. Unlike STAR TV which is a privately owned enterprise that can afford to "gamble" on subsidising of receivers for its bouquets (see p. 6, here), the Europeans must act like responsible public agencies. Most likely, the bouquet partners will use their considerable public relations ability to publicise the receiver (or receivers) selected for the As2 coverage region. One of the possible receivers is the Nokia DVB9500 S. Quite separate from the possible

1/ Bay Satellite TV Ltd at tel 64-6-878-9081; fax 64-6-878-5994.

2/ Panasat IRD520 was reviewed in SF#23, p. 12.

3/ See SF#26, p. 4 for brief update on a solution to taming the temperment of the IRD520.



sanctioning of this unit by the European Bouquet is the distribution of this unit into Australia and New Zealand by importers who have been told since late July to expect "initial trial units at any time."

For openers, the DVB9500 S is not simply another MPEG digital receiver. The Panasat, Pace, Scientific-Atlanta products are pretty useless for any purpose other than changing MPEG satellite transmissions into useful video and audio. The Nokia unit is described by its makers as, "A multimedia terminal for digital television, designed to be future-proof, it includes connectors for all consumer electronic products, a data interface connection to a PC, printer or CD ROM and the ability to receive new software that can be down-loaded via satellite or cable."

It is the latter feature which begs further detailing by Nokia. Their literature states: "It is expected that broadcasters will continuously increase and improve their offering of programmes and services to make them more attractive to viewers and make them easier to use. As consumers are not expected to want to install this new software themselves, Nokia has developed a solution - the multimedia terminal will recognise new versions of software being transmitted over satellite or cable and download them automatically."

This sounds a little but too good to be true. Does this mean that the terminal will recognise and accept the unique to S-A PowerVu format, for example, and adapt

## NOKIA DVB9500 S Announced Parameters

- **Bandwidth capability:** 2 to 54 MHz, or, a tiny segment of a transponder to a full bandwidth Ku transponder - on command.
- **Symbol rate:** 1.5 to 45 Mbits/second.
- **Conditional access:** PCMCIA-card capability; smart card slot included.

to its uniqueness? Not necessarily. The key here is whether the programme supplier is willing to make available through over-satellite transmission the software required to access their programming. The terminal's ability to receive, read, interpret and adjust to new software configurations should not be taken as a promise that the receiver will do this automatically without the partnership of the programmer.

Nokia in creating the DVB9500 S has taken the approach that a terminal need not be singular in function. They seem to be saying, "Hey - we are not certain which of the many promising digital systems will in the near future be important in the consumer marketplace - so, our terminal does everything!" So with an appropriate CD-ROM drive, it will play existing format music CDs, or the newer video CDs as available. With a built-in modem, the terminal can be used to communicate with programmers for pay TV ordering. It will also allow you to send and receive faxes or e-mail or access Internet. Connect it to a colour printer and it has a programme to allow you to take 'TV snapshots' of reception on the screen.

Nokia also claims the system allows use of an Electronic Programming Guide which they refer to as an "on screen magazine" using software that makes it possible to scroll through hundreds of channels and programmes on offer. What they do not say is that for this guide system to work the programmers must provide the basic data in a bit stream that is recognisable to the terminal. The same programme also allows the user to sort or batch programmes by title or topic (placing the week's guide supplied horse racing, for example, all together on a single listing).

Looking ahead, Nokia suggests the DVB9500 S is compatible with the "next generation of high-density recorders" that will store digital data such as sound, pictures and text. Digital VCRs are almost to the marketplace; digital camcorders are available in limited quantities now. The VCRs will ultimately be able to record directly from a satellite feed TV programming still in its MPEG format (i.e., tape storage will be MPEG rather than analogue). And the Nokia terminal will then be able to process the recorded material for playback on command.

Paramount in all of this pre-release hype are two key questions: When will this terminal be available, and, at what price. There are no hard answers to either question at this time.

### KTI DISHES

## ECHOSTAR RECEIVERS CHAPARRAL FEEDHORNS

• IN STOCK NOW •

**ECHOSTAR** LT5300 rec/pos \$750

**ECHOSTAR** LT8700 rec/pos \$900

**KTI** CKD 3.7m dish \$1450

HTS 24" actuator jack \$230

**CHAPARRAL** SideKick 20° C-band \$135

QUATRO Ku LNB 10.7 - 12.7 \$198

**CHAPARRAL** Super Feed C-band \$95

**CHAPARRAL** Dual Feed C-band \$120

**CHAPARRAL** Polarotor 1 C-band \$120

**CHAPARRAL** HTS Tracker C/Ku \$245

-all prices plus GST-

**OCTOBER SPECIAL: FREIGHT FREE IN NZ!**

KTI dishes C + Ku bands proven for analogue and digital!

## BARNETTS RADIO & TV SERVICE

42 Anderson Road • Wanaka

Ph/Fax (64)-3-443-7961

After hours Ph/Fax (64)-3-443-7476



# AV-COMM SATELLITE TV EQUIPMENT



## WORLD SATELLITE TV AND SCRAMBLING

Cat # B1020

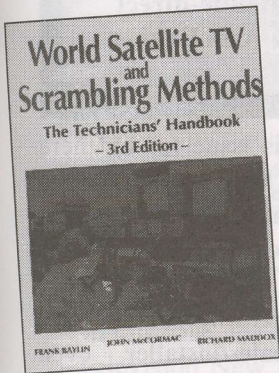

Known as "the technicians' handbook", this text is a must buy for technicians, satellite professionals, and enthusiasts. The design, operation, and repair of satellite antennas, feeds, LNBS and receivers are examined in detail. An in depth study of scrambling methods, and broadcast formats is the backdrop to a discussion of all current American and European satellite TV technologies, including the

Videocypher II, Oak Orion, Filmnet, UK Sky Channel, EuroCypher, D2MAC, BSB and Teleclub Payview III. Circuit and block diagrams of all components are presented and clearly explained throughout the book.....\$79

## WIRELESS CABLE & SMATV

Cat # B1011

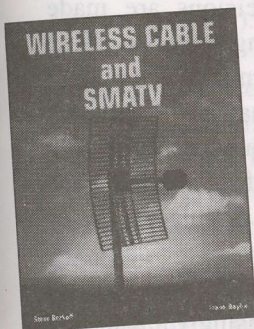

A comprehensive study of the new broadcast method, Wireless Cable, and the closely related field of satellite master antenna TV systems (SMATV). Three chapters are dedicated to details of the site survey, planning and design phases of a private cable system. Off air and satellite headends and all components from antennas to processing and mixing electronics are studied in detail. Ideal for those

considering an MMDS installation. ....\$89

## THE WIRELESS PRIMER

Cat # B1021

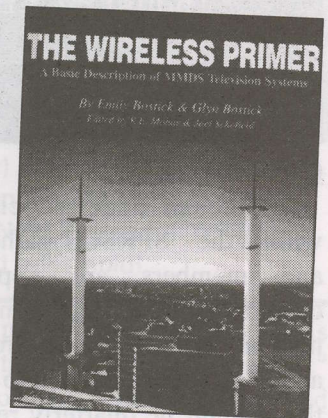

A 76 page complete description of MMDS television systems. This first edition, published in 1995, contains thirteen comprehensive chapters covering all aspects of system design, and shows actual on-air configuration of a 31 channel MMDS system. A valuable reference for anyone involved in installation or maintenance of an MMDS system, "The wireless primer" shows how one operator in the USA saved \$100,000 on hardware by following the designs in this book!! .....\$45

## 1995/96 WORLD SATELLITE YEARLY

Cat # B1013

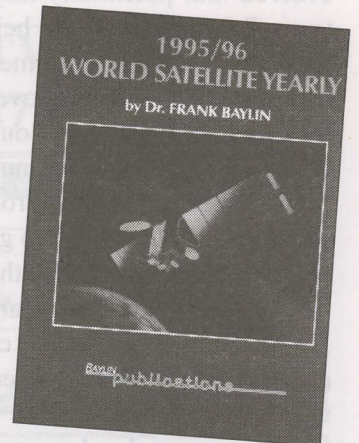

The 768 page 1995/96 World Satellite Yearly contains the latest information about satellites, technology and programming. Features updated chapters on audio and video compression, footprints for satellites launched during 1994 and projected for 1995/96, and worldwide programming assignments. The ultimate reference book on satellite TV footprints, programming and technology. ....\$140

## AV-COMM PTY. LTD.

DIRECT IMPORTER ACN 002 174 478  
PO BOX 225, BALGOWLAH  
NSW 2093 AUSTRALIA

TEL: (02) 9949 7417

FAX: (02) 9949 7095

CUSTOMER BULLETIN BOARD  
(02) 9905 0849

LIGHT YEARS AHEAD OF OUR IMITATORS



✓YES GARRY, Please send me

- 1 x World Satellite TV and Scrambling @ A\$79 Plus \$17 Airmail
- 1 x The Wireless Primer @ A\$45 Plus \$6 Airmail
- 1 x Wireless Cable & SMATV @ A\$89 Plus \$23 Airmail
- 1 x 1995/1996 World Satellite Yearly @ A\$140 Plus \$23 Airmail

Order two or more titles and we'll send your shipment freight FREE!!

Credit card No: \_\_\_\_\_

Signature \_\_\_\_\_ Expiry Date: \_\_/\_\_/\_\_

Name: \_\_\_\_\_

Delivery Address: \_\_\_\_\_

P'code: \_\_\_\_\_

a technical and marketing  
advisory

## memo

to the membership from your  
industry trade association

### SPACE Pacific

Satellite  
Programme  
Access  
Committee



A trade association for users, designers,  
installers, sellers of private satellite-direct  
systems in the Pacific Ocean & Asia Regions

#### Coping

Although trade association forums are conducted within the SPRSCS gathering annually in Auckland, and members are kept advised of significant developments through a membership newsletter forum, neither of these efforts provide quiet time to sit down and thrash out answers to irksome problems. Ideally, there might be quarterly regional meetings of members to allow participatory development of policy and to encourage creative solutions to universal problems.

Installer/Dealer, cable, and importer/distributor members in New Zealand are currently being asked for an indication of their willingness to attend a one-day seminar to deal with a number of items that have evolved into potentially major problems during the last year. Two meetings are being considered, subject to a showing of interest from members: One for Christchurch and one for Taupo over the same weekend in mid-November. A letter outlining this is in the mails at this time and if you are an Installer/Dealer member of higher, please respond promptly to allow planning to focus on staging these two gatherings.

Two major items are on the proposed agenda:

1) **Local government** and Resource Management Act interpretations creating (antenna/system) restrictions. How can we deal with these restrictions and win?

2) **Programming issues**; just how far should we push on programmers who are reluctant to offer their programming to various levels of users from home DTH through SMATV and cable?

As Coop's Comment notes in this issue (p. 1), there may well be a reason to consider legal action against programme suppliers who to date have been reluctant to make their services available at reasonable charges. This issue was first raised in SF#6 with the warning, "*Copyright quirks will play an increasing role in your TVRO future.*" The average dealer/installer, even distributors seem unwilling or unable to focus on the reasons why copyright remains a bigger challenge than other gnawing problems such as MPEG hardware incompatibility. People with a technical background can grasp the significance of a missing bit in a data stream but have greater difficulty accepting that someone sitting in an office in Hong Kong or Singapore can quite arbitrarily rule certain programme channels will simply not be available to specified countries.

A "discussion" of why such decisions are made invariably ends up in frustration. Telling someone living in the Chatham Islands (where government supplies a single short-day television service) that a "programme czar" living in Singapore has decided they cannot legally purchase HBO or TNT/Cartoons off of Palapa C2 leads only to anarchy. And the development of "black box" or "bootleg decoder" solutions.

Rather than encouraging or alternately condemning such individual decisions it is increasingly clear that where local law may impact on the way programmers do (or do not) make available their services, it will be necessary to establish some legal precedents. That means "going to court." This is the reverse of a programmer going to court to punish a user of a

## MEMBERSHIP IN SPACE

Membership in SPACE Pacific is open to any individual or firm involved in the "satellite-direct" world in the Pacific and Asia regions. There are four levels of membership covering "Individuals," the "Installer/Dealer," the "Cable/SMATV Operator," and the "Importer/Distributor/Programmer."

All levels receive periodic programme and equipment access updates from SPACE, significant discounts on goods and services from many member firms, and major discounts while attending the annual SPRCS (industry trade show) each January in Auckland. Members also participate in policy creation forums, have correspondence training courses available. To find out more, contact

(fax) 64-9-406-1083 or use information request card, page 30, this issue of SatFACTS. Page

space within SatFACTS is donated each month to the trade association without cost by the publisher.

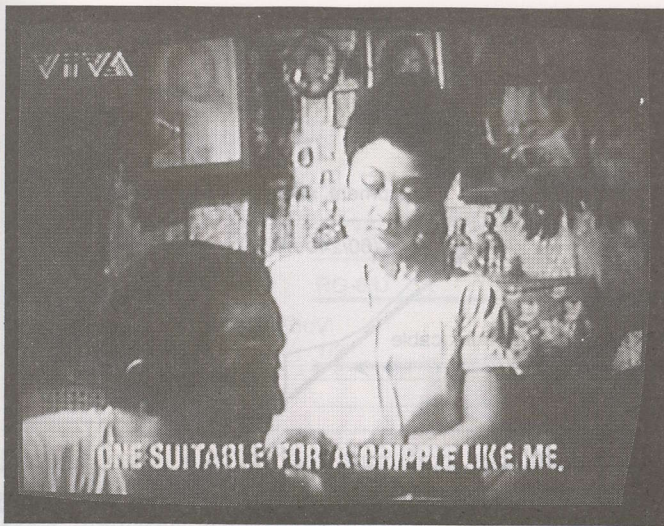

VIVA Cinema is a Filipino action-movie service carrying advertisements appearing in a STAR TV bouquet on AsiaSat 2 (see p. 6). Access? Maybe - maybe not!



BBC World (Asia Today) is available on PAS-2 within Sylmar bouquet and on As2 within STAR bouquet. Access? Not in New Zealand if Television New Zealand rules hold!

particular service because they have "hacked" their way in. In this case, the "suit" is begun by the "have nots."

Television New Zealand has a contract with BBC to deliver BBC World to New Zealand. They take segments of the BBC World broadcast day for their (UHF) Horizons five station chain which makes a few hours per day available to FTA terrestrial viewers in and around Christchurch, Wellington, Hamilton, Dunedin and Auckland. TVNZ also takes 6 to 7 hours per day for use by TV1 during the hours following normal close-down (between 1 and 2AM) and the start of the new broadcast day (typically 8AM). Basically, TVNZ uses BBC World in lieu of a test card for 'overnight service'.

TV1 covers all of New Zealand while the five TVNZ Horizons stations cover less than 40% of the land area. Cable operators in communities such as Doubtless Bay, Gisborne, Hawkes Bay, Taupo, and Greymouth would like to contract with BBC to carry the BBC World feed for at least the day part when TV1 is not using it. Television New Zealand says, "No, you may not have it for cable" offering carriage of their Horizons channels as a substitute. Unfortunately for the cable operators noted, the nearest Horizons station is "beyond" the horizon and not usable..

Comes now STAR TV which has similar BBC distribution rights for other portions of the Pacific and Asia. STAR says they will consider authorising cable firms for carriage of BBC World.

The TVNZ exclusive hold on BBC World raises a legal question or two. TVNZ is a state owned enterprise (SOE). And although it operates detached from

government, there are no private stockholders; it is owned by "the public." Yet that portion of "the public" living beyond reach of the Horizons broadcasts is denied access to BBC World, and TVNZ refuses to agree to terms that will allow access. In effect, a segment of the public is rendered "second class" because of a commercial decision by the publicly owned network. Is this any way to operate a state owned institution? A formal hearing could well force TVNZ to disclose the exact terms of their present BBC contract.

## FILTERS FOR ALL TV SYSTEMS \*YEAR #27!

For Example

Free Catalogs

### CABLE TV SYSTEMS

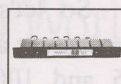

Channel Deletion



Channel Bandpass



Bandsplit

+ Your special needs

### TVRO & PRIVATE CABLE



Low-Cost Deletion



Anti-Radar Bandpass



Block-Band Pre-Select

+ Your special needs

### MMDS - "WIRELESS TV"



Relay Antennas

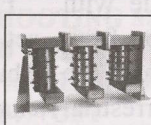

Channel Combiners

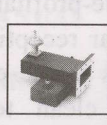

Line Components

### LPTV - "LOW POWER TV"

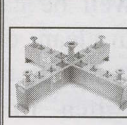

Channel Combiners

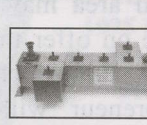

Transmitter Bandpass



Line Components



Emily Bostick  
President

*Emily Bostick*

Emily & Glyn Bostick -  
\*Continuing a generation of personal  
service to TV INDUSTRIES WORLDWIDE!

### BOSTICK FILTER DIVISION



7395 Taft Park Drive  
East Syracuse, NY 13057  
Mailing address:  
PO Box 3307  
Syracuse, NY 13220  
Tel: (315) 452-0709  
Fax: (315) 452-0732  
Canada & US: 800-882-1587

Contact our Distributor Maser Technology Group:  
New Zealand tel 64-9-479-7889  
Australia 61-2-9970-7644

# The CABLE Connection

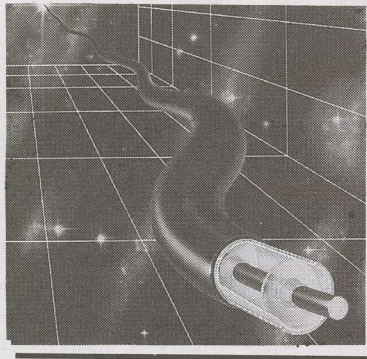

## Mini-Cable?

Throughout the Pacific there are many small "pockets" of population where television reception is poor or non-existent. At one end of the spectrum we have firms such as Foxtel and Optus in Australia, First Media and Saturn in New Zealand spending tens of millions of dollars per year rolling out 50-550 or 50-750 MHz bandwidth cable systems through heavily populated suburbs. A system for Auckland or Sydney will eventually pass several hundred thousand homes offering 50 or more channels of cable service and eventually high speed (10Mbps or greater) access to services such as Internet.

At the opposite end of the spectrum we have 25, 50, 100 homes clustered at the base of a valley, hidden behind a hill, or otherwise shielded from adequate (or any) television reception. Unless these "terrain disadvantaged" locations are within the cabling reach of the major players, it remains for a local entrepreneur to create a cable system to serve the needs of the people living in these niches. How small is "too small" for cable, and, how do you reduce the costs associated with building smaller systems?

The first need is always for adequate quality reception from the terrestrial networks. No matter where people live, and no matter how enriching satellite delivered programming may be, the majority of the people will spend the majority of their viewing time with TV stations that are supposed to (reception problems notwithstanding) "serve their area." A terrain disadvantaged area may well be cable-profitable with nothing more on offer than clean, clear reception from the terrestrial station networks. If this is the case, the cable entrepreneur will often find clean terrestrial signals at the top of the same ridge or hill that is blocking local reception. A set of yagi or log antennas, a preamplifier or two, and a signal processor for each off-air channel and you have the makings of a profitable cable business. If operating this equipment far from a locally available power line is a problem, use your aluminium trunk cable to send power from the bottom of the hill to the top through a step-down, step-up pair of power transformers. For most problems there are inexpensive, make-do creative low-cost solutions.

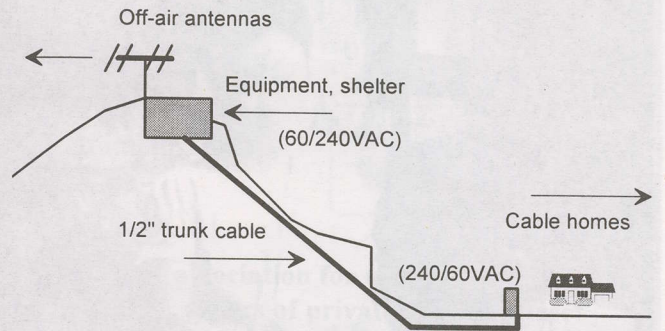

And while it may be nice to start off with heavy duty cable grade log or yagi antennas, in a pay as you go situation typical better-grade consumer antennas will get you started. The equipment can be installed in anything that will keep weather out just as long as it has ventilation to discharge the heat build-up.

What about the cable to run from the hilltop to the homes in the valley below? This is the tough decision. A 330 metre roll of quality RG-6/U costs around NZ\$300; just under \$1 a metre. Compare that with a 750 metre roll of 1/2" aluminium jacketed cable at around \$2.30 per metre. The 1/2" is cheaper but you pay another type of price: cable loss.

At the top of the hill the off-air antenna signals are amplified. This can be done 'on-channel' for as little as NZ/A\$300 per channel, or the off-air channels can be reconfigured to new channels you select for around NZ/A\$900 per channel using heterodyne processors. If you elect to move all off-air channels to band I (between 45 and 100 MHz) using heterodyne processors, for start-up all of your cable channels can be located within the lowest loss portion of the spectrum for the coaxial cable.

So let's assume you decide to invest in channel processors and to keep all initial cable channels between 45 and 100 MHz. By using channel processors, the audio and video carriers for each channel can be individually adjusted such that you can operate on immediately adjacent channels on the cable system without interference.

Experience is that virtually all band I, III and UHF TV set will also tune within band I from 45 to 90 MHz. Thus there is room between 55.25 and 83.25 for five TV channels on cable. You will not elect to use 45.25 (channel 1 in NZ) or 46.25 (channel 0 in Australia)

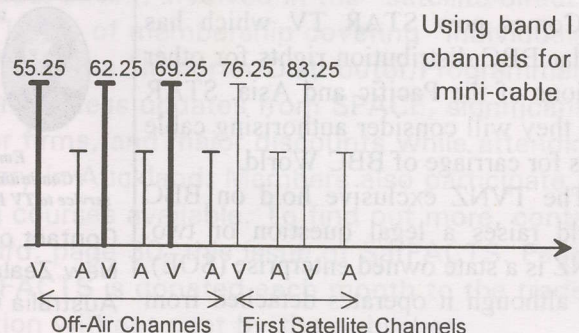

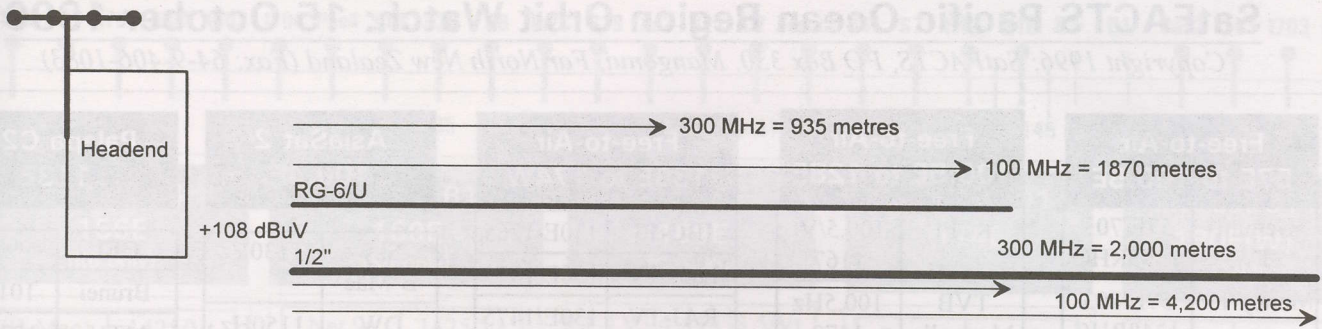

because cable quality line amplifiers available in the world market are designed to operate from 50 (or 54) MHz upwards. And sooner or later you will probably require line amplifiers.

Whether you elect the A/NZ\$300 on-channel signal amplifiers (and therefore use distribute the off-air channels on whatever channel fits your situation), or the A/NZ\$900 heterodyne channel processors, you will end up with approximately +108 dBuV of signal as you exit the headend equipment. How far with that +108 dBuV travel before reamplification is required?

In the drawing above we have four possibilities: Planning the system for RG-6/U cable using 300 MHz as our top end frequency, or, using 100 MHz as our highest frequency. Cable loss increases with operating frequency: With +108 dBuV output from the headend we can travel 935 metres with 300 MHz as top or 1,870 metres with 100 MHz as top. By comparison, with 1/2"

trunk we go 2,000 metres at 300 MHz and 4,200 metres at 100 MHz.

These distances are calculated on the basis that when you will need amplification, you will use a cable quality line amplifier that draws its power from a 30 or 60VAC source carried through the coaxial cable along with the signals. Such line amplifiers require +80 dBuV input level to operate properly so if we begin at +108 dBuV at the headend and the line amplifier requires +80 dBuV input, then we can stand 28 dB of cable line loss before our amplifier. The distances shown here reflect how much cable, at either 300 or 100 MHz, adds up to 28 dB of line loss.

In many smaller systems you can cover the entire area using only the amplification at the headend; i.e., no line amplifiers. If this is the your situation, then there are other savings possible as we will see next month.



## TELSAT COMMUNICATIONS LTD.™

SATELLITE TELEVISION CONSULTANTS, IMPORTERS AND EXPORTERS

Discover the World of Satellite Television

WITH THESE INTERESTING AND INFORMATIVE BOOKS



HOME SATELLITE TV  
INSTALLATION &  
TROUBLESHOOTING MANUAL  
4TH EDITION  
By Dr FRANK BAYLIN  
\$47+GST



THE WORLD OF  
SATELLITE TV  
1995 EDITION  
By MARK LONG  
\$40+GST

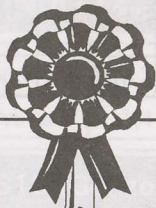

WHY BUY A DISH THAT DIDN'T EVEN MAKE THE TOP 5 AS VOTED BY THE U.S. TVRO DEALERS, WHEN YOU CAN GET AN ORBITRON VOTED 3rd OVERALL & THE BEST 3m DISH AVAILABLE IN N.Z.

**ORBITRON**



VOTED BEST  
FEED HORN

VONWEISE

VOTED BEST  
ACTUATOR

Voting results published in  
TVRO RETAILER Sept, 1996

CONTACT US NOW FOR THESE AWARD WINNING PRODUCTS AND MORE

17 Westhaven Grove, P.O. Box 1537, Palmerston North, New Zealand  
Tel: (06) 356-2749 Fax (06) 355-2141 Int'l + (64)6-355-2141 Cellular (021) 454-945

# SatFACTS Pacific Ocean Region Orbit Watch: 15 October 1996

Copyright 1996: SatFACTS, PO Box 330, Mangonui, Far North New Zealand (Fax: 64-9-406-1083)

Free-to-Air 57E to 100.5E	
Gemini TV	57E/703 1395RHC
Money TV	57E/703 1348RHC
Sun Movies	57E/703 1348LHC
Sun TV	57E/703 1220RHC
AsiaNet	57E/703 1170RHC
WorldNet	57E/703 1095RHC
NEPC	57E/703 1092/LHC
TVi	57E/703 1015LHC
Azerbaij.	57E/703 980LHC
Discovery India	68.8/Pas4 Vt/1360
Sony Ent.	68.8/Pas4 Vt/1239
Movie Club	68.8/Pas4 Hz/1117
CNN	68.8/Pas4 Vt/1061
TNT+	68.8/Pas4 Vt/1036
BBC World	68.8/Pas4 Vt/995
MTV & Jain TV	68.8/Pas4 Vt/966
TW6 Mos.	80E/1275
MAPTV	80E/1475
Moscow 1	90E/1475
Moscow 2	90E/1275
India 1	93.5/1025
India 2	93.5/1060
India 3	93.5/1420
CCTV	96.5/1325
Moscow 1	96.5/1475
Value Ch.	100.5/ 1488Vt

Free-to-Air 100.5E to 128E	
RTPi	100.5/Vt 1167
TVB Mongolia	100.5Hz 1470
CCTV Henan TV	100.5/Hz 1422
CCTV Guandong	100.5/Hz 1310
CCTV-4 Beijing	100.5/Hz 1183
Moscow 1	103.1/ 1472
Star TV	113/Vt 970
CFI	113/Hz 990
MTV Asia	113/Hz 1030
TPI	113/Hz 1070
TV Indosair	113/Vt 1090
ABN	113/Hz 1120
ANteve	113/Vt 1130
CNNI	113/Vt 1170
SCTV	113/Hz 1190
GMA	113/Hz 1230
TV3	113/Vt 1250
ATVI	113/Hz 1270
TVRI	113/Hz 1310
RTM	113/Vt 1330
RCTI	113/Hz 1350
CNBC	113/Hz 1530
JCSAT3 (test)	128/Vt 1166 & 12290Hz

Free-to-Air 130E to 174W	
IBC-13	130E/1265
Laos TV	130E/1375
RAJ-TV	130E/1475
Saudi TV	140E/1275
Moscow 1	140E/1475
Udaya	142E/1225
EMTV	142E/1265
EagleNet	142E/1325
ASN	142E/1475
Moscow 1	145E/1475
NHK	169E/Hz 1115
CNN	169E/Hz 1183
Value Channel	169E/Vt 1400
CCTV-4 (MPEG)	169E/Hz 1426
RFO	180E/1105
WorldNet	180E/1179
CNBC	174W/Hz 990

**S19 (?) (Gorizont)  
96.5E (RHC)  
+/- 3.3 deg (?)**

Jain TV	1,275
Muslim TV	1,425
Orbita II	1,475

**S21 (Gorizont)  
103.2E (RHC)  
+/-2.0 deg.**

APNA	1,375
Orbita II	1,490

**R41 (Gorizont)  
130E (LHC)  
+/-0.9 deg.**

IBC-13	1,265
Laos TV	1,375
RAJ-TV	1,475

AsiaSat 2 100.4E	
Sky B-Mac	1130Vt
DW Bouquet (DVB MPEG)	1150Hz 1/DW 2/MCM 3/(RAI) 4/TVE 5/TV5
RTPi	1167Vt
CCTV-4	1183Hz
Reuters	1230Hz
STAR Japan (DVB MPEG)	1250Vt 1/"Plus" 2/BBC 3/VIVA 4/CNBC 5/horse racing 6/Sky
CCTV-2	1310Hz
APTV	1351Hz
News-crypt	1390Hz
STAR Asia (MPEG/CA)	1410Vt 1/"Plus" 2/BBC 3/VIVA
CCTV-1	1430Hz
STAR Asia (MPEG/CA)	1450Vt A/D/Star B/D/Star C/D/Star
TVB Mongolia	1470Hz
Value Channel	1488Vt

**Russian Polarisation**  
S (Stationar) series satellites are RHC (right hand circular); R (Rimsat) are LHC (left hand circular)

Palapa C2M 113E	
CFI	990Hz
Brunei	1010Vt
MTV Asia	1030Hz
ESPN (B-Mac)	1050Vt
TPI	1070Hz
TV Indosair	1090Vt
ABN	1120Hz
ANteve	1130Vt
HBO (B-Mac)	1150Hz
CNNI	1170Vt
SCTV	1190Hz
GMA	1230Hz
TV3	1250Vt
ATVI	1270Hz
TVRI	1310Hz
RTM	1330Vt
RCTI	1350Hz
(data)	1370V
TNT+ (B-Mac)	1390Hz
(data)	1410Vt
Discovery (B-Mac)	1430Hz
CNBC	1530Hz
STAR SE Asia MPEG	1570Hz
STAR SE Asia MPEG	1650Hz

## NOTES:

C2M replaced C1 at 113E over period 28 June - 1 July. **Bold "OK"** NZ on 3m.  
Russian R,S series satellites are inclined orbit;  
+/- indicates extent of present inclination.

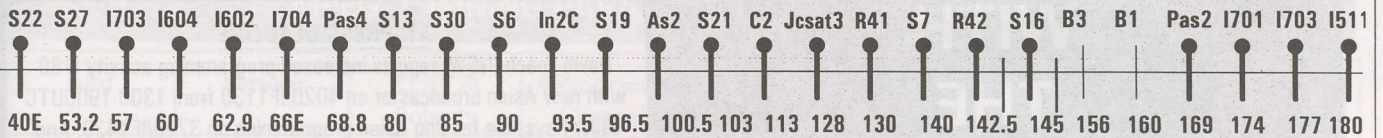

**OPTUS B3  
156E  
(Ku only)**

(B-Mac)	1425/Vt
Central ABC HACBSS	1393/Hz B-Mac
Vic. ETV	1361/Vt CryptV.
Imparja TV	1329/Hz B-Mac
(B-Mac)	1297/Vt
Net 9, Sky specials	1233/Vt B-Mac
Central ABC HACBSS	1201/Hz B-Mac
	1169/Vt
Galaxy	1137/Hz Irdeto Mpeg 2
	1105/Vt
Galaxy	1073/Hz Irdeto Mpeg 2
Golden West	1041/Vt
	1009/Hz
	977/Vt

**S7 (Gorizont)  
140E (RHC)  
+/- 4.4 deg.**

Saudi TV	1,275
Orbita I	1,475

**S16 (Gorizont)  
145E (RHC)  
+/- 3.9 deg.,**

Moscow 2	1,275
Moscow 1	1,475

**OPTUS B1  
160E  
(Ku only)**

Net 9, Sky feeds	1425/Vt B-Mac
Data	1402/Hz
QSTV	1377/Hz B-Mac
NE ABC HACBSS	1370/Vt B-Mac
NE SBS HACBSS	1344/Vt B-Mac
SE SBS HACBSS	1339/Hz B-Mac
SE ABC HACBSS	1313/Hz B-Mac
Sky Channel	1296/Vt B-Mac
ABC Radio	1276/Hz (digital)
OmniCast	1270/Vt (FM/FM)
ABC feeds	1247/Hz Pal
Net 7	1244/Vt E-Pal
Net 9 feeds	1219/Vt Pal&Ntsc
	1214/Hz
Net 10	1182/Vt E-Pal
Net 9	1180/Hz E-Pal
Net 10 feeds	1155/Vt Pal
Net 7	1120/Vt E-Pal
Net 9 feeds	1091/Vt Pal
CAA air to ground	1009/Vt Nbfm
CAA air to ground	977/Vt Sepc(fm)

**PAS-2  
169E  
(C + Ku)**

CCTV3,4	1433.5/Vt (Sa9223)
Abn/Ctn/Cctv/Nbc	1,426/Hz (Sa9222)
Value Ch.	1400/Vt
Discovery PowerVu	1374/Hz (Sa9223)
MTV Asia	1346/Vt B-Mac
ESPN	1288/Vt B-Mac
MPEG-2 PowerVu Sylmar	1249/Hz (Sa9223)
TNT+ (1/2Tr)	1218/Vt B-Mac
CNN+ (1/2Tr)	1183/Hz
FoxSports	1161/Vt (Sa9222)
NHK	1115/Hz
Filipino Channel	1060/Hz (GI Mpeg)
NBC Mux MPEG	1057Hz (Pace)
MPEG-2 PowerVu HonKong	1002Vt (Sa9223)

**PAS-2 Ku**

PowerVu	12415V
H-Life	12,520V
Karaoke	12,730/H

**R42 (Gorizont)  
142.5E (LHC)  
+/- 0.9 deg.**

Udaya	1,225
EMTV	1,265
EagleNet	1,325
RPN9 Sa9223	1,375 PowrVu
ATN	1,465

**Intelsat 701  
174E**

Feeds	963
Feeds	984

**Intelsat 703  
177E**

AFRTS	973 B-Mac *
Feeds	980

\* uniquely left hand circular

**Intelsat 513  
177W**

Feeds	963
Feeds	984

**(513 Ku)**

Service	RF Freq.
US Nets	10980Vt
NBC	11015Vt
Feeds	10510Vt

**Ku Services**  
Intelsat Ku band services shown here are boresighted to Japan and nearby Asia, have not been reported south of equator. At boresight, signals of < 2m levels.

**TDRS5 / 174.3W**

CNBC	990Hz
BBC World	1190Hz MPEG

**UPCOMING SATELLITE LAUNCHES**  
October 15/ INSAT 2D  
January '97/ JCSAT-4 to 150E  
January '97/ Indostar (S-band) to 106E  
January '97/ ApStar 2R to ??E  
February '97/ I1801 to 174E.

**Intelsat 511  
180E(W)  
+/- 2.9deg.**

TVNZ	964/Ntl 3000
TVNZ	972/Ntl 3000
TVNZ	980/Ntl 3000
TVNZ	988/Ntl 3000
(data)	1,054
Canal +	1,054 **
(data)	1,092
RFO Tahiti	1,105
Asian	1,130
World-net	1,179
Aust. 9	1,220
Keystone	1,256
NBC/e	1,277
Mpeg tests	1,310
Mpeg tests	1,325
Mpeg	1,388
Keystone	1,432

\* RHC & LHC  
\*\* LHC only e/ encryption

**(511 Ku)**

Service	RF Freq.
CBS	11480Hz
CNNI	11510Hz

TDRS5 "north" only

New satellites: B2P now at 144E (no reports); C1 at 150.5E (data reported 1410Vt).



# WITH THE OBSERVERS

## AT PRESS DEADLINE

David Leach (NSW) reports increased programming activity 1180 with new Asian broadcaster on 4020/IF1130 from 1300-1900UTC daily; Keystone feeding Asian programming on 3720/IF1430. And, Australia 9 has shifted from IF1021 to IF 1220 with improved signal levels. Additional reports are solicited!

Launch dates for Intelsat 801, 802 and 803 have been adjusted once again with significant side effects for the Pacific region. Intelsat has been battling to maintain their leadership role into the Pacific but has been steadily losing market ground to PanAmSat and more recently Palapa and others promised during 1997. One of the most significant delays will be the launch of a possible 10+ channel programming service put together by USA based international cable operator UIH which we detailed in SF#20, p.22. This service (known at this time as "APV") is supposed to include 10 channels of "basic" programming collected from world-wide sources, plus as many as 8 additional "premium" programming channels. UIH has signed a first refusal agreement with Intelsat to utilise 72 MHz of C-band space on 801 when it goes to 174E (see below).

PanAmSat and Hughes Electronics Corporation are planning a merger which will have significant repercussions throughout the Pacific region. As planned, the 4 PAS birds now operating plus their 4 new birds to be launched between now and the end of 1998 will merge with the fleet of 13 Hughes birds which primarily serve the Americas to create a sizeable international service. One of the first outgrowths of this merger is news that Hughes "PC Direct" Internet service will expand into Australia and New Zealand sometime before the end of the first quarter 1997. This service will utilise Ku downlink spectrum on PAS-2 (169E) and offer a 128kbps link to Internet at a monthly fee of US\$1,250. There will also be an installation fee that covers the dish system, digital satellite transceiver,



Luo Shin Gang's rooftop mounted antenna system at Shenzhen Fu Sheng Communication Co., Ltd., Shenzhen, P.R.C. Changing birds looks like it could be an interesting exercise!

### REVISED LAUNCH SCHEDULES - to 15/10/96

- 16 December: Tempo-1 Proton launch
- 17 December: PanAmSat PAS-6 Ariane 4
- ?? January: JCSat-4 Atlas-2AS launch
- ?? January: ApStar 2R CZ-3B Chinese launch
- ?? January - Indostar 1 launch
- ?? February: Mabuhay CZ-3B Chinese launch
- ?? February: Intelsat 801 Ariane 4 launch
- ?? March: Thaicom 3 and BSAT-1A Ariane 4 launch
- ?? May: Intelsat 802 Ariane 4 launch
- ?? July: PanAmSat 5 Proton launch
- ?? August: Intelsat 803 Ariane 4 launch
- ?? September: ChinaSat 1 Long March launch
- (02 September: Partial solar eclipse visible from Australia, NZ)

CODEC unit and a TCP/IP router. The CODEC converts analogue signals to digital (and in reverse) since the digital waveform drives the Ku transponder control system out of control. That data services including Internet will be "big news" in 1997 is well accepted in the industry; there is life "after television" on those satellites!

**Gary Stapley** (Christchurch, NZ) using Islander 4.5m found data channel operational on IF1410Vt from what should be Palapa C1 at 150.5E. Routine use, TV or other, from C1 is still unknown. Indonesia "owns" the 150.5E spot but prior to the "C1 accident" at 113E had always considered it as a "storage location" rather than an operating orbital slot.

**Steve Jepson** (Levin, NZ) and many others are reporting the "Herbalife Channel" on PAS-2, Ku at IF1220 vertical. This is a training service operating Monday and Wednesdays from 11PM (NZST; 8PM AEST) typically for two hours on the Australian and NZ beam. More than 80 Ku terminals have been supplied to Herbalife reps in both countries in a project that promises to grow rapidly. Jepson also comments on the terrible signal level quality from EM TV typically most mornings. EM TV relies upon the PNG Telecom for uplinking and as we all know the 142,5E Russian satellite is becoming

**WITH THE OBSERVERS:** Reports of new programmers, changes in established programming sources are encouraged from readers throughout the Pacific and Asian regions. Information shared here is an important tool in our ever expanding satellite TV universe. Photos of yourself, your equipment or off-air photos taken from your TV screen are welcomed. TV screen photos: If PAL or SECAM, set camera to f3.5-f5 at 1/15th second with ASA 100 film; for NTSC, change shutter speed to 1/30th. Use no flash, set camera on tripod or hold steady. Alternately submit any VHS speed, format reception directly to SatFACTS and we will photograph for you. Deadline for November 15th issue: November 4 by mail (use form appearing page 30), or 5PM NZT November 5th if by fax to 64-9-406-1083.

## MPEG-2 TUNING PARAMETERS (15 October 1996)

Bird	Service	RF/IF & Polarity	# Programme Channels	FEC	(k)(M)s/s	
As2	EBB	4000/1150Hz	5TV, 9 radio (a)	3/4	28. 125	Interoperable Receivers (1) NTL,DGT400(2),DVR 500, IRD520
	Star +	3900/1250Vt	7TV, 1 radio (b)	1/2	28. 100	
	APTV (news)	3799/1251Hz	1TV, 1 aux	3/4	5. 632	NTL
R42/142.5E	RPN-9	1375LHC	1TV, 1 radio	unknown	unknown	NTL, Comstream
PAS-2	TCS Singapore	4183/967Hz	2TV	1/2	6. 62	Scientific Atlanta
	Discovery Singapore	3776/1374Hz	1TV, possibly more	3/4	19. 850	S-A PowerVu
	NBC HK Philips	4093/1057Hz	7TV (d)	3/4	29. 473	S-A PowerVu
	SA-California PowerVu	3901/1259Hz	7TV (e)	3/4	30. 800	NTL, DGT400(2), DVR500, IRD520
	SA-California PowerVu	12415/1115 Vt	7TV (e)	3/4	30. 800	S-A PowerVu
	CCTV China PowerVu	3716.5/1433.5 Vt	2TV (f)	3/4	19. 850	S-A PowerVu
	SA-HK PowerVu	4148/1002Vt	6TV (c)	2/3	24. 430	S-A PowerVu
Optus B3	Galaxy	12438Hz	20+ TV	3/4	29. 473	DGT400(3)

1) Interoperable receivers: Receivers which have proven through repeated use to be capable of reliable digital reception for the programme service(s) listed. 2) Pace (Galaxy) DGT400 units will only work on these services if they have not been over-the-air "upgraded" to include 'Programme Censorship' classification function. 3) Access to Galaxy programming requires smart card; a guide/barker channel can be received using Panasat IRD520, Pace DVR-500 units without smart cards. a) through e): See SatFACTS August 15, 1996 for listing of individual programme service channels (add test of Golf Channel to programme channel 7, SA California service). f) CCTV3 pgm ch. 2, CCTV4 pgm ch 1. Discovery uses pgm ch. 50 (not a typo; they are numbered 10,20-60).

# U P

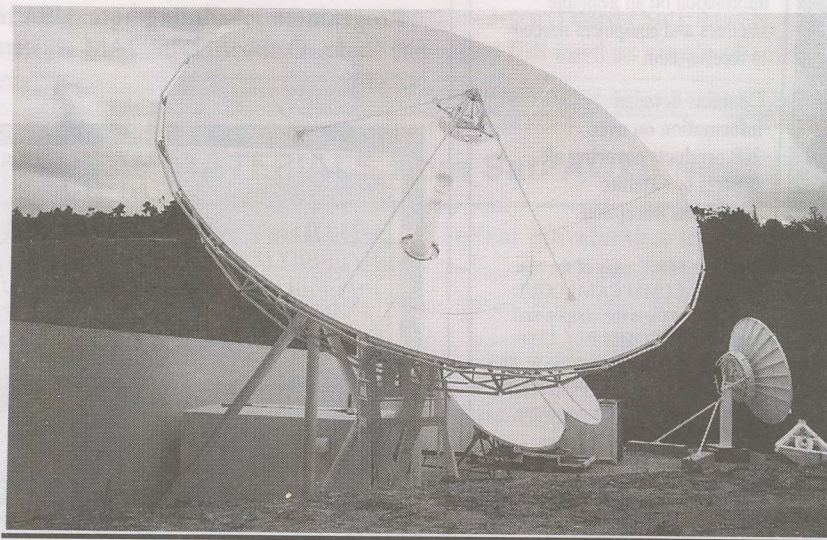

# and running!

POSSIBLY the ONLY privately owned teleport in the Southern Hemisphere; scheduled for regular use first quarter 1997. Through 13m and smaller antennas, we can connect to virtually any P.O.R. bird; TV, radio, data, even Internet. Curious?

**New Zealand Teleport Holdings Ltd. • Whangaparaoa, NZ**  
 Bryon G.G. Evans at Tel/fax 64-9-424-0841/Mobile 025-789-160



Trade supplier of quality equipment

- Echostar
- Gardiner
- Panasat
- KTI
- ADL

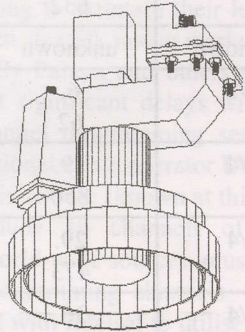

In Australia

Phone: (09) 306-3738

Fax: (09) 306-3737

<http://www.omen.com.au/~pmerrett>  
33 Kentia Loop, Wanneroo  
WESTERN AUSTRALIA 6065

## NOT COMING TO A NEWSAGENT NEAR YOU!



The new 1996 AV-COMM SATELLITE TV CATALOGUE, contains up to the minute information on all available satellites and equipment needed to receive them.

Contains detailed information on over 200 products covering all aspects of Satellite Television Reception.

For your FREE copy of the new 1996 AV-COMM CATALOGUE simply complete the coupon and send to: AV-COMM PTY. LTD. P.O. Box 225, Balgowlah NSW 2093.

YES Garry, please send me a FREE copy of the 1996 AV-COMM Satellite TV Catalogue.

AV-COMM PTY LTD

A.C.N. 002 174 478

198 Condamine Street,  
Balgowlah NSW 2093  
Tel: (02) 9949 7417/9948 2667  
Fax: (02) 9949 7095

Name: \_\_\_\_\_

Address: \_\_\_\_\_

Postcode: \_\_\_\_\_

Phone: ( ) \_\_\_\_\_



EM TV officially kicked off scheduled use of Videocrypt encoding with Baywatch (Monday nights, 8.30PM PNG time) September 16. Encoding allows them access to more mainstream programming including heavy Cricket schedule during October. (Photo courtesy Q.O.H, PNG)

increasingly "inclined" each month. It appears that after regular programme shutdown at EM TV each evening the PNG uplink techs neglect to keep on tracking the satellite until they again remember to find the satellite the next morning!

Roger Hughes ((Kalamunda, WA) and others report Galaxy, still in financial woes, is offering the DGT400 at A\$619 "for sale" rather than merely renting it to subscribers. The versions now being offered have been "updated" with the dreaded programme censorship software but the earlier version without the upgrade "may be offered in the future" according to Roger.

Home Box Office plans to launch a new 24 hour movie channel, Cinemax, on 15 November via ApStar 1.

Service interruption October 9th between 06.30 and 06.40 UTC for the European Bouquet was not a failure of your system; DW was conducting transponder gain and gain flatness tests of their AsiaSat 2 transponder in that period.

CNN video failure just after 0000UTC October 6 on PAS-2 was them, not you!

Programme scheduling note: USA moves their clocks back one hour October 27th 2AM eastern (October 28: 7PM NZST).

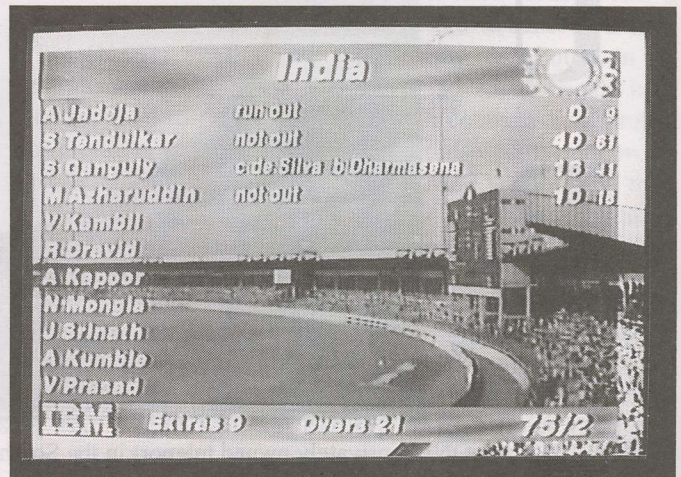

RIGHT place, right time. Non-scheduled feeds of international matches including this Cricket test on PAS-2 is a matter of luck (Steve Jepson, NZ)

**EVERY MONTH - MAJOR NEW CHANGES!**  
**SUBSCRIBE TO SatFACTS USING THIS FORM**

**A most incredible year to date - more than 40 new television programme channels available and for properly equipped and located viewers in the South Pacific, another 50+ by April 1997. TO STAY INFORMED of the South Pacific satellite revolution enter your SatFACTS subscription TODAY!**

- ENTER my 12 MONTH subscription to SatFACTS starting with NOVEMBER 15th issue (rates below)  
 ENTER my 36 MONTH subscription to SatFACTS starting with NOVEMBER 15th issue (rates below)

NAME \_\_\_\_\_  
Company (if applicable) \_\_\_\_\_  
Mailing Address \_\_\_\_\_  
Town/City \_\_\_\_\_ Country \_\_\_\_\_

**Amount to send:** 1 year - NZ\$40/A\$75/\$US40 (outside NZ and Australia) or 3 years - NZ\$100/A\$175/ US\$100 if by cheque. **VISA?** See form below and return with order. Return to: **SatFACTS, PO Box 330, Mangonui, Far North (NZ)** or if by **VISA** by FAX to 64-9-406-1083.

**USE THIS FORM ONLY WHEN CHARGING ON VISA CARD**  
(and PLEASE ALSO COMPLETE TOP PORTION AS WELL!)

**Please charge my VISA card as follows:**

- One Year of **SatFACTS MONTHLY** (NZ\$40/A\$75/US\$40)  
 Three years of **SatFACTS MONTHLY** (NZ\$100/A\$175/US\$100)  
 **SATELLITE TELEVISION: The Booklet** (NZ\$10/A\$12/US\$10)  
 One year of **COOP'S TECHNOLOGY DIGEST** (NZ\$125/A\$125/US\$125)  
 The **WORLD of SATELLITE TV-1992 edition** (NZ\$15/A\$20/US\$20)

Name (as it appears on **VISA** card) \_\_\_\_\_

**VISA** Card Number: \_\_\_\_\_ - \_\_\_\_\_ - \_\_\_\_\_ - \_\_\_\_\_

**VISA** Card Expiration date: \_\_\_\_\_

**Instructions:** If ordering by mail, return this complete (3-part) card (SatFACTS, PO Box 330, Mangonui, Far North, New Zealand); if ordering by FAX, send full card as single sheet to 64-9-406-1083.

**SUPPLEMENTAL MATERIALS from SatFACTS MONTHLY: Order Form**

- SATELLITE TELEVISION: The Booklet.** Excellent introduction to home dish ownership for the layman with contributions from world famous science writer *Arthur C. Clarke*. The perfect tool to help the system seller explain dish ownership to prospective customers, from **SPACE Pacific**. NZ\$10/ A\$12/ US\$10 by fast post.
- COOP's TECHNOLOGY DIGEST.** For the really serious enthusiast, investor, business person in satellite TV and allied industries. Ten issues per year, jam-packed with information you will not find anyplace else. "Coop" routinely culls more than 60 monthly publications, \$1,500 per year newsletters, Internet and his hundreds of private contacts to keep you up to date on the **REAL** changes underway in telecommunications. Conveniently issued near **first** of the month, provides excellent time-line-filler between mid-month issues of SatFACTS. Now in 4th year, airmail world-wide. Normally NZ/A/US \$250 per year; for limited time 50% off offer at NZ/A/US\$125.
- WORLD OF SATELLITE TV - 1992 edition.** The famous *Mark Long* handbook that takes a novice and turns him or her into a satellite TV pro! 1996 edition \$45 or more; this special offer only NZ\$15/A\$20/US\$20.

## OBSERVER REPORTING FORM - Due NOVEMBER 4, 1996

- **New programming** sources seen since October 1st: \_\_\_\_\_
- **Changes** (signal level, transponder, programming content) in pre-existing programming sources since October 1st: \_\_\_\_\_
- **Other** (including changes in your receiving system): \_\_\_\_\_

**Note:** Please use P1-5 code when describing reception quality and receiver IF or RF settings.

Your name \_\_\_\_\_  
Town/City \_\_\_\_\_  
Make/Size dish \_\_\_\_\_ LNB \_\_\_\_\_ Receiver \_\_\_\_\_

**Mail:** SatFACTS, PO Box 330, Mangonui, Far North, New Zealand. **Fax:** 64-9-406-1083

### TELL SF: HOW WELL DO YOU SEE CNBC ON PALAPA C2M at IF1530 Hz?

CNBC (NBC Asia) free-to-air service currently running on C2M (113E) on horizontal polarity, IF1530, is a "reference" to gauge coverage of the new STAR TV South East Asia MPEG digital bouquet also on C2M, same polarity (see p. 6, here). To "map" the potential of this new STAR TV service, we ask that you check out CNBC on C2M and supply the information below:

1) Rate CNBC on C2M at 1530 Hz from P1 to P5 when using 22 or 27 MHz bandwidth and no threshold extension: \_\_\_\_\_

2) Size of your dish: \_\_\_\_\_ 3) Degree LNB: \_\_\_\_\_ 4) Is your feed rated for the extended band (3.4-4.2 GHz)? \_\_\_\_\_ 5) Is your LNB rated to perform in the extended band (3.4-4.2)? \_\_\_\_\_

Your Name \_\_\_\_\_  
Your location \_\_\_\_\_

Return to: **SatFACTS/Star, PO Box 330, Mangonui, Far North, New Zealand** (fax 64-9-406-1083)

### TIME IS RUNNING OUT TO PLAN YOUR TRIP TO AUCKLAND FOR SPRSCS '97!

INFORMATION PACKS describing the 1997 South Pacific Region Satellite & Cable Show (January 21-25 in Auckland) are being distributed **NOW**. Make plans **today** to attend this excellent show and return this form to be assured of receiving the detailed announcement.

YES - send me SPACE SPRSCS '97 show packet!

I am  am NOT  a member of SPACE Pacific.

NAME \_\_\_\_\_

Address \_\_\_\_\_

Town/City \_\_\_\_\_

**Return to:** SPACE Pacific, PO Box 30, Mangonui, Far North, New Zealand

# UNIDEN SATELLITE TELEVISION

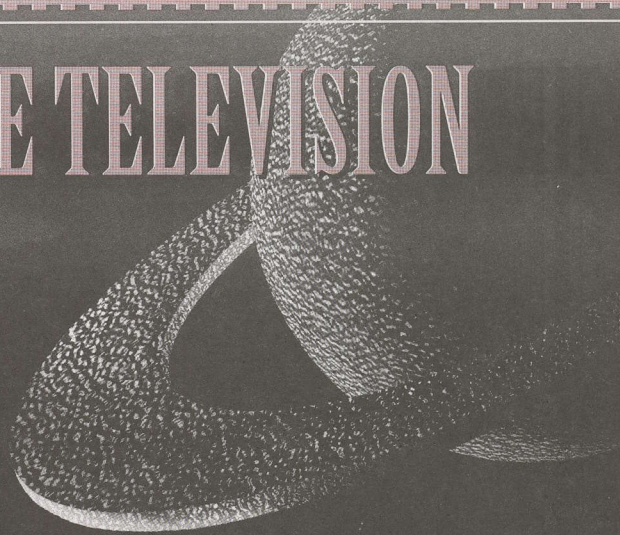

## *JUST IMAGINE...*

*Over thirty channels of free-to-air television from around the globe available throughout New Zealand. even in areas where present free-to-air or paid channels don't reach.*

*THIS IS NOT A DREAM, It's a reality. And it's available to your customers right now, with equipment costs that are probably a lot less than you would expect.*

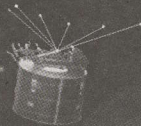

*Uniden are about to launch their Satellite Television Package to dealers throughout New Zealand.*

*If you would like to find out how to profit from satellite television in New Zealand give Uniden a call.*

*After all, Uniden is one of the world leaders in satellite television technology.*

## UNIDEN SATELLITE TELEVISION

*Putting You Face To Face With  
A World of Entertainment*

**uniden®**

*a Clear Signal of What's Ahead*

*For more information Phone 0-9-273 8383 or Fax 0-9-274 0009*

*Uniden® is a registered trademark of the Uniden Corporation of Japan Ltd and is represented in New Zealand by Uniden (NZ) Ltd.*