

11 July 9:30 AM

Bob Cooper's

JULY 15 1996

# SatFACTS

MONTHLY

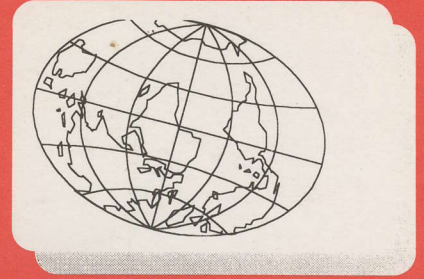

Reporting on "The World" of satellite television in the Pacific Ocean Region

## IN THIS ISSUE

**DIGITAL  
RECEIVER  
IDIOSYNCRACIES**

**DVB TEST:  
PANASAT  
IRD520**

**POST-  
MORTEM:  
D9223**

- ✓ Latest Programmer News
- ✓ Latest Hardware News
- ✓ Latest SPACE Pacific Reports
- ✓ Cable TV Connection

Vol. 2 ♦ No. 23

Price Per Copy:  
NZ\$8/A\$9/US\$5





# Paraclipse<sup>®</sup>



CLASSIC  
SERIES

ECLIPSE  
SERIES

HYDRO  
SERIES

When quality, strength, and accuracy are your main requirements, **Paraclipse** antennas are your first choice.

Only **Paraclipse** offers such variety; four distinctly different series:

- the Truss-Ribbed Classic,
- the Courier Deliverable Eclipse,
- the Stretch Formed Hydro,
- the Commercial Patriot.

Every **Paraclipse** model sets the industry standard in its class, worldwide.

Distributed in New Zealand by  
**Bay Satellite TV Ltd.** PO Box 14050 Hastings  
Tel: 64-6-878-9081 Fax: 64-6-878-5994

**Paraclipse<sup>®</sup>**  
HIGH PERFORMANCE ANTENNAS

Paraclipse Inc.  
2271 29th Avenue East, Columbus, Nebraska USA 68601  
Telephone: (402) 563-3625 FAX: (402) 564-2109





# SatFACTS

## MONTHLY

SatFACTS Monthly is published 12 times each year (on or about 15th of each month) by Far North Cablevision, Ltd. This publication is dedicated to the premise that as we enter the 21st century, ancient 20th century notions concerning borders and boundaries no longer define a person's horizon. In the air, all around you, are microwave signals carrying messages of entertainment, information and education. These messages are available to anyone willing to install the appropriate receiving equipment and, where applicable, pay a monthly or annual fee to receive the content of the messages in the privacy of their own home. Welcome to the 21st century - a world without borders, a world without boundaries.

**Editor/Publisher**  
**Robert B. Cooper**  
(ZL4AAA)  
**Office Manager**  
**Gay V. Cooper**  
(ZL1GG)

**Reaching SatFACTS**  
**Tel: 64-9-406-0651**  
**Fax: 64-9-406-1083**  
**Mail: PO Box 330**  
**Mangonui, Far North**  
**New Zealand**

**Subscription Rates**  
Within NZ: NZ\$40 p/y  
Australia: AV-COMM Pty  
Ltd, PO Box 225,  
Balgowlah NSW 2093  
61-2-9949-7417  
Elsewhere: US\$40 p/y

**ERRATA**  
SatFACTS Copyright 1996  
by Robert B. Cooper; any  
form of copying is a  
violation of our  
international copyrights.  
Advertising rate sheet  
available upon request.

## COOP'S COMMENT

déjà vu, all over again (with apology to Yogi Berra). God I hate to see this happening.

In another life I would rather repress in the back of my mind an American company introduced an analogue encryption scheme which they claimed would "secure" satellite transmissions from unauthorised eyes. The system (which had a trade name starting with the letter V) was widely adopted by American cable TV programmers and offered to home (DTH) viewers for an inflated (outrageous) fee. A number of computer literate DTH enthusiasts

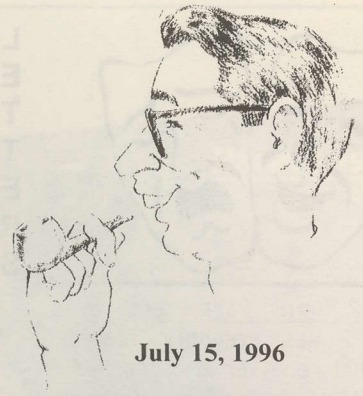

July 15, 1996

```
$01c:ffff ffff ffff ffff ffff ffff ffff ffff
$02a:ffff ffff ffff ffff ffff ffff ffff ffff
$031:ffff ffff ffff ffff ffff ffff ffff ffff
$038:ffff ffff ffff ffff ffff ffff ffff ffff
$03f:ffff ffff ffff ffff ffff ffff ffff ffff
$046:ffff 5341 5053 ffff ffff ffff ffff ffff
$04d:ffff ffff ffff ffff 0000 0000 0000 0000
$054:ffff ffff ffff ffff ffff ffff ffff ffff
$05b:ffff ffff ffff ffff ffff ffff ffff ffff
$062:0000 0000 2616 2968 2db4 1d 1d 1d
$069:ffff ffff ffff ffff ffff ffff ffff ffff
1-Init 2-Erase 3-Default 4-Clear
```

Segment of buried D9223 software

set out to "bust" the system and within 18 months did so; so successfully that ultimately the "V system" would be totally replaced with a "V2" version. Millions of consumer people lost billions of US\$ in this transition and in the process C-band DTH in fell into a sales slump from which it never recovered.

Now, ten years down the road along comes MPEG-2. We were told it was the best thing since sliced bread, that it would offer unlimited new programming sources and for the first time in the history of television on this planet create a single, international standard for TV transmission. And we (all of us) were naive enough to believe that individual manufacturers had put aside their competitive urges in favour of a single, world-wide, TV marketplace.

### Foolish us.

As the report on page 18 here relates, everything we have been promised about DVB Compliant MPEG-2 is a lie. It is not universal, it is not a world-wide standard, and moreover whereas at one time we had only SECAM, PAL and NTSC to cope with (and sort out through standards conversion), within MPEG-2 DVB Compliant "standards" there are hundreds, perhaps thousands of "variations" which clever firms such as S-A can use to manipulate the TV picture and sound to their own private advantage.

When I protested to a sympathetic and knowledgeable S-A engineer late in June, she said to me: "*What we have done (with PowerVu) is not illegal, and it is in fact DVB Compliant. But then so too is the DMV (NTL) system, and the TV/Com.*"

So the engineers have invented a new term to describe what they have created: *Interoperable*. Loosely translated it means, "*If you will tell me, an engineer, what your 'secret codes' are inside your system, I can probably resoftware my receiver to unlock your transmissions.*" For those of us without an engineering degree in MPEG-2, we are stuck with their creations. And a string of unique, one of a kind receivers.

One receiver which accesses everything transmitted? Not in this century.

## In Volume 2 ♦ Number 23

THE REAL WORLD OF MPEG-2 RECEIVERS  
IDIOSYNCRASIES of Digital Installations -p. 6  
Panasat IRD520 "DVB Compliant" Test -p. 12  
Post-mortem: Last Shoe Drops on S-A D9223 -p. 18

### Departments

Programmer / Programming Update -p.2; Hardware / Equipment Update -p.4  
SPACE Notes: Planning SPRSCS '97 -p.20 ;  
The Cable Connection / Tiering of Programme Packages -p.22; SatFACTS Orbit Watch  
-p.24; With The Observers -p.26; MPEG-2 Tuning Parameters -p.27;  
July Reporting Form -p.30; SPRSCS '97 Reg Form -p.30

### -ON THE COVER-

A real one! This Panasonic IRD520 "DVB Compliant" MPEG-2 receiver came to SF July 1 just in time for test and a report here. A year down the road, it will be remembered as the "first" consumer unit to appear in the Pacific and Asia.





L  
E  
T  
T  
E  
R  
S

#### MPEG-2 Tuning Parameters?

I was recently loaned a Pace DGT-400 receiver and learned that for it to recognise the data stream 1) the FEC value must be correct. 2) the symbol rate must be within +/- 5 symbols/sec. and 3) I had to be within +/-4 MHz of the correct IF. I also learned that chasing these parameters on a Pace DGT-400 is slow and tedious. Ideally a receiver would be capable of scanning for the appropriate parameters within defined limits. Is this possible?

Simon Judge. ACT. Australia

Possible but perhaps not yet practical. We understand that scanning will require 'bumping' a parameter (such as FEC) a step at a time and then scanning symbol rate through defined range. If you also have to scan for the correct IF, the receiver is searching for two variables against one fixed parameter. Initially, scanning MPEG receivers are likely to require that you define the correct IF and they will then bump and scan. SF will do updates of our June 15th listing of MPEG-2 parameters as often as we deem essential (see p. 27).

#### Word From The Gang

Here in China we sell GI and S-A IRDs, satellite TVRO reception equipment, and satellite magazines. We also have organised a TVRO 'Fan Club' of interested people.

Luo Shi Gang, Hu Shenzhen, P.R.C.

Strange that a country that bans private TVRO ownership and greatly restricts access to programming services has GI and S-A IRDs for sale, and a TVRO 'Fan Club'! Another of those mysteries of the Far East.

#### A Matter of Interpretation

In reviewing the response (SF) received from S-A concerning whether or not their PowerVu is indeed 'DVB Compliant'. I can only comment that there are many loop holes in MPEG-2/DVB leaving room for proprietary-inclined manufacturers to do their own thing.

-continued on page 4-

## PROGRAMMER PROGRAMMING PROMOTION

## UPDATE

JULY 15, 1996

**C2M swapped** for C1 at 113E between June 28 and 1 July; details p. 26.

**Global TV Service** (142.5E, IF1375) promised 24 hour service 1 July with adult "Plus 21" 1630-2030UTC did not make schedule; see update p. 28.

**Mongolian TV** (MTB in Cyrillic) began regular transmissions using As2 horizontal 3680 MHz at 0900UTC on July 2nd. This is a SECAM signal, audio on 6.6 and is widely reported as being of same level as two regional Chinese services that launched in late May.

**JSKY** is the operating name for Murdoch/Sky package planned for Japan. The service will have a digital capacity of 100 programme channels most of which will be supplied to JSky(B) by Japanese broadcast producers, not the Murdoch Sky empire. The first-toe-in-the-water service, Star Plus transmitted within the programme mix on AsiaSat 2 (3900Hz), claims 60 Japanese cable TV affiliates serving 400,000 Japanese homes. The next major Japanese programming addition is to be a movie channel scheduled for December debut. There is no firm date for launch of the 100 channel service beyond vague references to "the middle of 1998."

**Upsetting to Star TV.** A major hotel in China has somehow obtained an NTL 3000 receiver and is receiving and distributing to rooms Star Plus MPEG-2 service now fed via As2 into Japanese cable systems. No big deal - except. Except: Chinese have not approved use of this service in China, consider content to be not acceptable within China, and officials from China are leaning on Star to correct this situation "before it gets out of hand." How? Conditional access of course. On the plus side for Star: None of the Pace, Panasat, S-A MPEG-2 receivers will access these feeds so they remain 99% secure for now.

**Upsetting to BBC.** World Service TV feed is now carried PAS-2 (1249Hz, PowerVu) because satellite reaches several regions of the world where BBC service, until now, has been missing or of poor level. Korea was one new "market" which BBC would gain with PAS-2 service. Alas, Korean regulations prohibit importation of S-A 9223 IRD unit although "shell" unit is actually manufactured in Korean plant. BBC office in Seoul, to obtain their own World Service feed, had to arrange with S-A Canada to ship 9223 "authorisation board" (which is not a Korean product) to Korea where the local plant that builds the 9223 shell installed it. No import rules broken since complete 9223 was not imported.

**MPEG 1.5 close down:** Sylmar feed (1408/Vt with CMT et al) now scheduled to shut down 30 July. Anyone with S-A 9222 still running on this feed will be without service. Hong Kong feed of PowerVu (1002 Vt, PAS-2) has run into technical difficulties and switch off of existing CTN/ABN/CCTV/NBC service on MPEG 1.5 (1426 Hz) is delayed to at least 1 September. As we go to press, 1002 service has been shut down because of technical problems. When 1426 is cleared of MPEG 1.5, The Value Channel, currently vertical 970IF, is due to move to horizontal TR2 (1420IF).

**Olympic coverage** will swamp all available satellite circuits from 18-20 July onward. Some will be digital, majority will be analogue and FTA on PAS-2, I174E, I177E, I180E and I177W.

**Christchurch (NZ)** Japanese family sued by city for 3m dish has lost court case (SF#22, p. 19), are returning to Japan and will not appeal decision.

**RAI Uno and MCM?** Although menu-listed on EBB, they had not appeared as of 5 July. Update? RAI Uno suggests "Early July start" for their service; no word from MCM.





Paracclipse

Paracclipse  
full range  
down under!

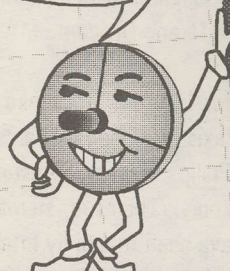

2° space 17.750MHz 80dB -40 to +140° 3.0 KHz 750mV 5Amps AC/DC 5 to 800MHz 1GHz 5 to 2000MHz 1GHz 2° 0.5 m  
2° space 17.750MHz 80dB -40 to +140° 3.0 KHz 750mV 5Amps AC/DC 5 to 800MHz 1GHz 5 to 2000MHz 1GHz 2° 0.5 m  
2° space 17.750MHz 80dB -40 to +140° 3.0 KHz 750mV 5Amps AC/DC 5 to 800MHz 1GHz 5 to 2000MHz 1GHz 2° 0.5 m  
2° space 17.750MHz 80dB -40 to +140° 3.0 KHz 750mV 5Amps AC/DC 5 to 800MHz 1GHz 5 to 2000MHz 1GHz 2° 0.5 m

# Paracclipse Antennas

- High efficiency perfect reception
- Precision hydroformed and mesh antennas provide years of trouble-free reception
- Exceptionally distortion-free C and Ku band reception, even from 2° spaced satellites
- One piece hydroformed reflectors
- Heavy-gauge aluminum antenna adds structural strength
- Protected with a baked-on powder-coat finish
- Self-aligning, three pole feedhorn support
- A heavy duty, pre-assembled, fully adjustable polar mount

Available from:

**SKANDIA ELECTRONICS PTY. LTD.**



Head Office: 183 Burwood Road Hawthorn, Victoria, Australia 3122

Tel: (613) 9819 2466 Fax: (613) 9819 4281

NSW Office: 4/411 Church Street Nth Parramatta, NSW, Australia 2151

Tel: (612) 630 0888 Fax: (612) 630 8690





Once an S-A, always an S-A. Or was that GI + S-A?

Again, it appears that some (MPEG 2) receivers expect all of the various SI tables to be present or to include certain information in a certain way while other receivers will work on a subset. Until somebody steps up to do compliance testing, it will just be finger pointing.

Someone who knows better. Hong Kong SF 'shared' our exchanges with S-A concerning the D9223 with several MPEG-2 knowledgeable design and field engineers throughout Asia and Europe.

What we tend to overlook is that MPEG-2 is not just receivers, it is a complete system and each manufacturer so far has been involved in building encoders, conditional access systems, and multiplexers to marry two or more programme channels to a single transponder. DMV/NTL, or S-A or Tiernan has no interest in selling only receivers or encoders; each wants to sell every part of the

network from uplink input to downlink output. And they can eliminate the competition by building into their uplink SI (system information) data stream variations which only their receivers routinely recognise. An analogy? Kodak builds cameras to operate with 35mm film; Nikon builds theirs to operate with 34mm film. Canon requires 36mm film. And all three sell cameras and manufacture film. Can you imagine how long it would take for a fourth company to create a "universal sprocket hole" film that fit everyone's camera?

That's where we are today: waiting for the "universal sprocket hole IRD." And all responses to our shared information said pretty much the same thing: see page 18 here.

#### Demo Tapes?

We have need of a promo video tape to show prospective satellite system purchasers, in particular the programming that will appeal to ethnic groups from Asia. With the variety now available on As2, C1/C2M, Rimsat and PAS-2, surely somebody can produce such a tape (for a fee) and make it available?

Peter Simmonds. Duckworth's (NZ) Limited speciality tapes for CCTV, CTN and ABN have been available but we know of no composite tape that shows everything up there. Anyone want to tackle this?

## HARDWARE EQUIPMENT PARTS

## UPDATE

July 15, 1996

**These are confusing times department:** Irdeto is correct spelling of Netherlands based conditional access firm, not Iredito as we have from time to time misspelled. And South African PanaSat receiver (not PanSat) is only loosely related to Panasonic, contrary to popular reports, and is built by 'NPC Electronics Limited' of South Africa. One more? DVR-500, a rebadged DGT-400, will use same Irdeto conditional access module as Galaxy now has in Australia. And? And, DGT-400, DVR-500 both have 4megs of video RAM inside, not the 16megs we suggested in June SF.

**NBC Hong Kong PAS-2 uplink (1057, Vt)** is Philips Token Mux equipped. At this time there are three DVB Compliant uplink hardware suppliers with equipment installed in any quantity in the Pacific/Asia: Philips, NTL and Divicom. S-A? Not (really) DVB Compliant (see p. 18, here).

**MPEG-2 receiver brand names?** CLI, Comstream, Divicom, DMV (aka NTL and commercial only), Echostar (a rebadged Sagem), Galaxis (designed by Samsung), General Instrument, Grundig, KDD, Pace, PanaSat, Philips, Sagem, Samsung, Scientific-Atlanta, Sony, STS, Tanberg (commercial only), Thomson, Tiernan, TV/Com, Uniden, and Wegener. Those underlined have been tested by Intelsat with 12 different MPEG-2 brand encoders and have been found to work with 3 (25%) or more of the encoders not of their own manufacture (i.e., interoperability). Others (example: General Instrument) work with nobody's encoder but their own. Detailed report in Coop's Technology Digest for July 12.

**S-A9223 post-mortem.** SF received S-A confirmation June 28 this receiver cannot be configured in the field for European Bouquet (DW et al) reception but may be capable of being reconfigured by S-A centres (such as Sydney) to receive one (only, at a time) of the EBB programme services. Details p. 18.

**Big losses.** Three 1996 satellite launchers have filed insurance claims seeking compensation for satellites that arrived at their Clarke Orbit locations in defective states. Claims totalling US\$100m have been filed by AsiaSat (for As2 Ku defect) and Palapa C1 (for myriad of problems including 50% failure of solar powering array).

**RTVE on EBB (Bouquet) As2.** Their off-satellite analogue feed to Israeli As2 uplink, where conversion to MPEG-2 takes place, is noisy (below threshold) creating unusual "sparklie digital signal." Sparklies occur randomly, moving about from frame to frame (i.e., 25 times per second there are new sparklie locations in the picture). MPEG-2 only transmits new "video" information frame to frame and new sparklies constitute new "information." Net result? Analogue noisy RTVE signal makes the digital system "work harder" because the sparklies constitute new video information frame to frame. Which explains why RTVE may randomly "lock" on screen for no apparent reason.

**Australia's decision to "adopt" S-A PowerVu** is attracting strenuous objection from a number of Australian broadcast groups. Timeline forecast for replacement of existing B-Mac HACBSS service with PowerVu is two years or more into future.

**No change department:** Latest Intelsat advisory lists launch date for VIII-1 to 174E via Ariane launcher as "October 1996." When this happens and Intelsat is satisfied VIII-1 is functioning properly, 701 will move from 174E to 180E replacing progressively more inclined 511. Next up: VIII-2 for January 1997 launch to 177E replacing 702/3 at that location.

**Additional sources** for Panasat IRD520 (page 12, here) as we go to press: Bay Satellite TV Ltd. (tel 64-6-878-9081) and Antares Satellite Products (tel 61-7-3205-7574).



# ADL<sup>®</sup>

BECAUSE PERFORMANCE IS ALWAYS YOUR FIRST PRIORITY

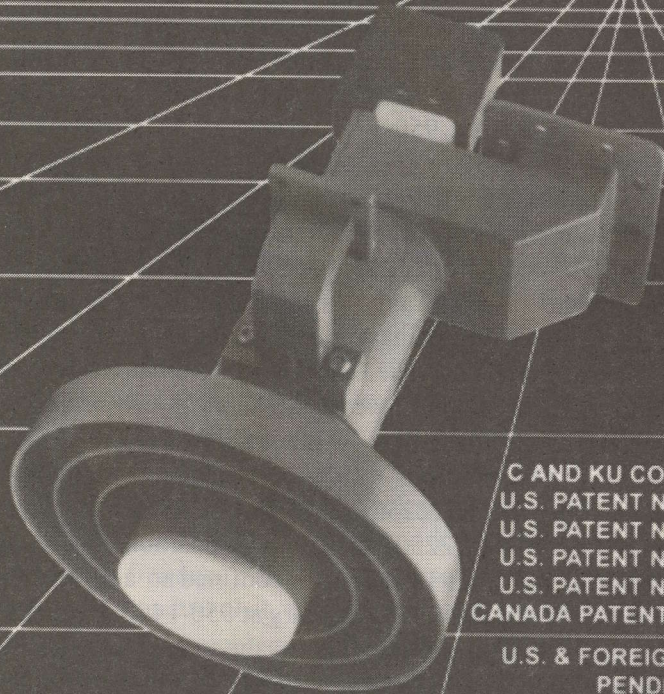

**RP3-CKU/ International  
Adjustable Scalar Ring Feed  
with Extended C Band**

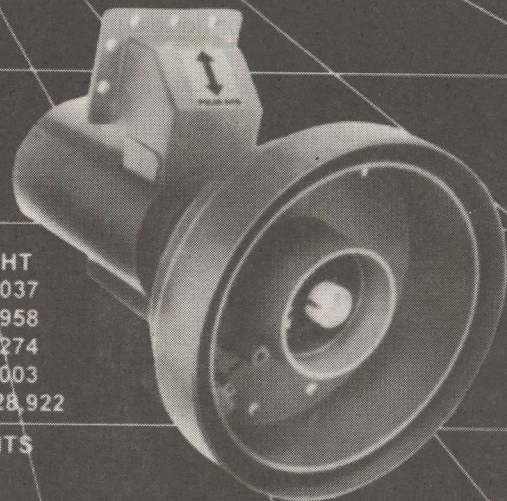

**RPI-CKU Feed**

C AND KU CO-BORSIGHT  
U.S. PATENT NO. 4,903,037  
U.S. PATENT NO. 5,066,958  
U.S. PATENT NO. 5,107,274  
U.S. PATENT NO. 5,255,003  
CANADA PATENT NO. 1,328,922

U.S. & FOREIGN PATENTS  
PENDING

## ADL HYBRID MODING CIRCULAR POLARIZED INTELSAT FEEDS WITH EXCLUSIVE T.I. REJECTION



**RP1-CP400**

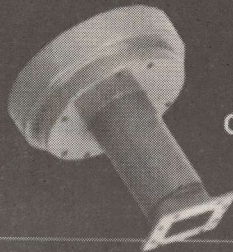

**CP-300**



**CPOR-100**

- C BAND LINEAR & CIRCULAR • C/KU LINEAR & CIRCULAR • KU 12 GHz FEEDS
- INTELSAT 4 GHz CIRCULAR • ARABSAT S BAND FEEDS

OPTIONAL: CO-BORSIGHT S BAND

2216 AGATE COURT, UNIT B, SIMI VALLEY, CALIFORNIA 93065 • (805) 526-5249 • FAX (805) 584-0634



## DIGITAL RECEIVER IDIOSYNCRASIES

### Care and Feeding

MPEG digital receivers are proving to be more sensitive to installation and set-up techniques than their analogue cousins. And within the MPEG family of receivers different brands (and models) respond differently to identical installation techniques. Only wide scale use of the various receivers will uncover all of the more common "sensitivities" and at this point in MPEG receiver deployment we are still on the early part of the learning curve. What we already know is that receiver installation techniques suitable for analogue will often produce indifferent or no results with digital.

### The "Spec" Problem

The input to a digital IRD is commonly specified as 75 ohms (impedance) across some stated bandwidth (such as 950-2,050 MHz) with an input signal level ranging between two limits (-30 to -65 dBm [S-A S9223]; -28 to -63 dBm, or as they specify 44 to 79 dBuV [Pace DVR-500]).

The input frequency range (950-2050 MHz or as stated by the individual receiver model specifications) tells you the range of IF (intermediate frequencies) which the receiver has been designed to tune. In the not-so-long-ago analogue world, a receiver intended for use at Pacific or Asian receive sites needed to tune the IF range that matched the output frequency spectrum produced by the LNB (low noise blockconverter). And as the satellites were typically downlinking in the 3700 to 4200 MHz (or 3.7 to 4.2 GHz) region, the "width" of the tuning range at the intermediate frequency region was matched to the 500 MHz spread of the downlink band.

That was prior to Palapa (C1 and C2M) and AsiaSat 2. All three satellites have extended the downlink range below 3700 MHz (see table, here) which means reception from these satellites within their extended range will occur below 3700 MHz. C-band LNBS invert the frequency spectrum in the conversion process and 3700 MHz becomes 1450 at IF. Therefore, 3600 would appear at 1550 and any frequencies lower than 3700

require a receiver that tunes above 1450. This is why some existing analogue receivers have difficulty tuning the Russian satellites operating in the 3675 MHz range (which becomes 1475 at IF).

Receivers sold into the Pacific and Asia have primarily offered an IF tuning range of 950 (same as 4200 at C-band) to 1450 (same as 3700 at C-band). However, European models began to expand the IF tuning range (first 950-1750, then 950-2050 and more recently 950-2150 or even higher) because of the unique frequency assignments that have come into use over Europe in Ku band. The original European Ku band was 500 MHz wide, from 12250 to 12750. A Ku band LNB creates the same IF range as a C-band model although obviously the downlink input band is significantly higher in frequency. The explosion in Ku-band use over Europe, Africa and western Asia forced satellite operators to open new bands, below 12250 MHz. Several LNB solutions followed; some use a switching circuit to process 12250-12750 in one switch position and 11750 to 12250 in another position. In both instances the LNB IF output is confined to a 500 MHz bandwidth and nominally appears at 950-1450. Note that Ku-band LNBS do not invert the spectrum; 12250 appears at 950 and 12750 appears at 1450 in the receiver IF band. With a "switch" 11750 appears at 950 while 12250 appears at 1450.

Receiver suppliers saw a way of making their receivers more desirable; expand the IF from 950-1450 to 950-some higher number (1750, 1950, 2050, 2150). Now one LNB without switching could in fact process the spectrum from as low as 11550 to 12750. The 950-1750 receivers were available for a brief period and then the standard quickly became 950-2050.

Unfortunately not all European design receivers consider C-band as an option; the software in the Radix Alpha 70 (for example) nominally refuses to accept an LNB that operates with the local oscillator on the "high side"; a requirement for C-band operation.

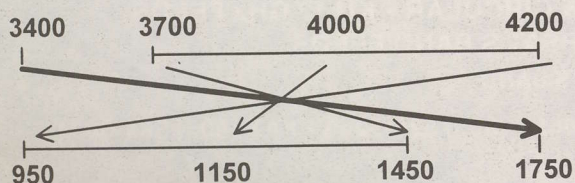

Satellite	Downlink Frequency Range
AsiaSat 2	3600-4200
Palapa C1	3400-4200
Palapa C2M	3400-4200



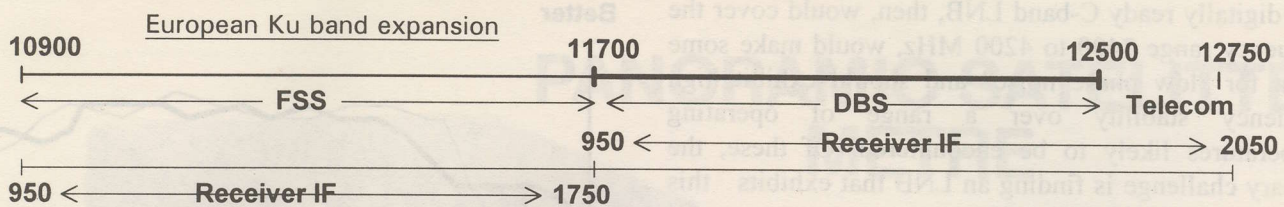

### The LNB Factor

LNBs operating for C-band typically place their "local oscillator" at 5150 MHz or above the incoming downlink frequency band (in the 3700-4200 range). Ku-band LNBs operate with their local oscillators below the incoming frequency band; 11300 MHz has been a common local oscillator ("LO") frequency for Ku in Asia and Pacific where the primary Ku activity is between 12250 and 12750.

When the LO is above the frequency of the incoming signals, the 500 MHz band is reversed at IF; 4200 becomes 950 while 3700 becomes 1450. This means that if you know the incoming downlink frequency, the IF is found by subtracting this number from the LO frequency; 5150 - 4000 equals 1150 IF.

When the LO is below the incoming frequency, you subtract the LO from the incoming frequency to identify the IF; 12250 - 11300 equals 950 MHz (1). When you read a frequency assignment plan for C-band, high becomes low (at IF) while at Ku low remains low.

It would seem that if both C and Ku LNBs reduce the incoming frequency range to 950 - some higher number, the same receiver that works with C will also work with Ku since to the receiver the input it sees is always inside of the receiver tuning range. There is one more consideration.

When the LO is on the high side (C-band), the "polarity" of the receiver video output is reversed from what it would be with the LO on the low side. You can test this with any receiver equipped for selectable C or Ku use. A receiver left in the "Ku operating position" will produce negative looking pictures when used at C as well as when used at Ku in the C position. Less expensive receivers typically provide a rear apron switch marked "C/Ku" which does nothing more than reverse the polarity of the video signal at the demodulator stage depending upon the switch position. More expensive receivers operated by menu selected software build this switch into the software; select a C-band input parameter and the output video is

automatically set to the appropriate video polarity position. A software driven receiver without this video polarity routine will work on only one band; C or Ku. There are also a few C-band only economy receivers which lack the switch as well. A clever person can correct this problem by modifying the receiver video demodulator stage detector adding a new switch to reverse the polarity of the video on command.

Digital receivers will require an expanded IF tuning range to be used with some of the (as yet unspecified) services.

In addition to the tuning range of the receivers, the signal processing range of the LNB must also be expanded. A "standard" 3700 - 4200 MHz input C-band LNB does not cease working at 3700 but the "guaranteed" performance does not include ranges below 3700. Analogue reception LNB performance is based upon three criteria:

- 1) Gain which is specified in dB over a stated bandwidth (the "gain/bandwidth product"),
- 2) Noise temperature specified in degrees Kelvin at C-band and in dB (fractions) at Ku band, and,
- 3) Frequency stability, specified in MHz (megahertz) of drift over a stated temperature range or period of time.

For digital reception purposes, a fourth ingredient is added: Phase Noise. Basically, less phase noise is desirable but in LNB testing on digital services to date, it is not at all clear how much phase noise is bad and under what circumstances (2).

In a digital service the bandwidth of the signal becomes of concern when the service occupies only a portion of a transponder. You can tell which services are utilising less than a full transponder by the megasymbol rate; APTV, for example, is 5.632 Ms/s and occupies approximately 1/4th of a transponder. A less than full transponder will create problems for the receiver if the LNB frequency stability is poor. It is also possible phase noise may become more of a negative factor when the bandwidth is reduced.

1/ For Ku use, an LO of 11300 produces an IF range from 950-1450 when the downlink band is 12250-12750 (i.e., Optus, PanAmSat, JCSAT-3). In Europe LNBs with two LOs or twin LNBs create outputs in the 950-2150 IF range as shown above with downlinks spread from 10700 to 12750. LNBs with two LOs on different frequencies (or twin LNBs) switch between the two LOs on tone or voltage command from the receiver.

2/ On marginal high megasymbol rate MPEG services, attempts to improve the bit error rate (BER) by changing out from non-digital to digital-rated LNBs does not appear to improve the BER. This raises questions concerning the absolute value of digitally rated LNBs.



A digitally ready C-band LNB, then, would cover the frequency range 3400 to 4200 MHz, would make some claim for "low phase noise" and should exhibit high frequency stability over a range of operating temperatures likely to be encountered. Of these, the primary challenge is finding an LNB that exhibits this performance below 3700 MHz

There is one more adaptation to be considered: The frequency range of the feed antenna. An LNB that includes the feed antenna as an integral part (such as the Chaparral Micropak) is already bandwidth limited by the LNB electronics (i.e., 3700 to 4200 MHz). The feed antenna portion of the package further inhibits performance below 3700 MHz.

All feeds designed for 3700 to 4200 MHz will exhibit degraded performance below 3700; the further below 3700 you go the greater the loss in performance. This happens at the same time the gain and noise temperature of the LNB are also failing. The combination of these losses can quickly add up to significantly degraded reception (on, for example, the CNBC analogue feed at 3620 MHz Palapa C1).

Feed and LNB manufacturers can be expected to re-certify the performance of their devices over the expanded frequency range (3700 MHz and below). At the present time, lacking this essential information, it is not possible for users of this extended frequency range to determine the best choices in feeds or LNBs for use below 3700. You should assume only that equipment designed for optimum performance between 3700 and 4200 is not going to work as well between 3400 and 3700. How much worse? A several dB degradation in carrier to noise is likely, causing a 12' dish to work like an 8, a 10' as a 6.

What does this have to do with MPEG digital reception? Everything if it happens to be located in the 3400-3700 frequency region and you are trying to resolve it on a 3700-4200 MHz system.

To date, footprint signal levels from digital transponders have universally been lower than their analogue counterparts. There are several sound reasons for this at the satellite itself. AsiaSat 2 footprints over New Zealand, for example, are several dB below expectations although to the north (New Caledonia) and west (Australia) levels are at least as high as anticipated (3). It is the combination of being outside of the design frequency range and facing reduced satellite eirp levels which adds up to significant problems for system planners.

3/ Steffen Holzt (Noumea) reports As2 using 2.5m Micromesh Orbitron, 25K LNB following C/NRs : Hz1429/10, 1390/10, 1310/7, 1188/7, 1150 (EBB MPEG)/4. Vt1171/7, 1130/7, 1420 (Star MPEG)/4dB.

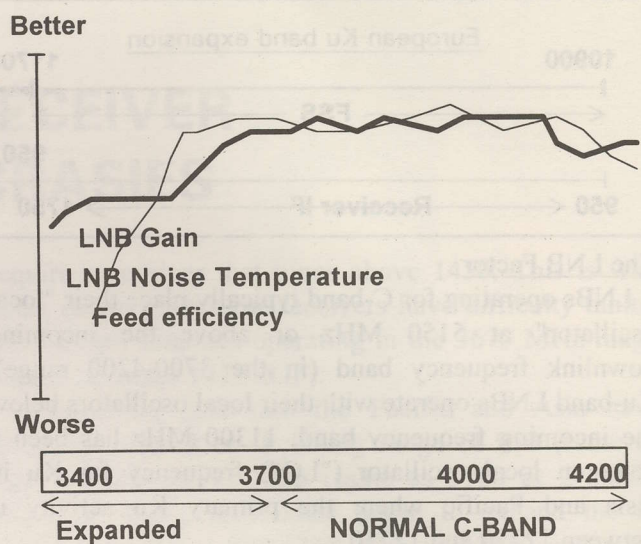

Digital transponders are often operated, under instruction from the satellite operator, at eirp levels which are 3 to 5dB below the peak levels attained by an analogue signal on an adjacent transponder. This 3 to 5dB "back off" in operating power equals or exceeds the "threshold advantage" which digital offers. In other words, if an analogue receiver requires a 8dB C/NR (carrier to noise ratio) to reach threshold, in theory a digital signal of the same transponder width could be at (digital threshold) with a C/NR between 4 and 5dB; clearly a 3 to 4dB advantage for the digital. However, if the digital modulated transponder eirp is reduced (backed off) by 3 to 5 dB because of satellite design (linearity) constraints, then we are basically back where we started. There is no threshold advantage of digital under these conditions and the user ends up requiring the same size dish for threshold digital as would be required for threshold analogue.

Much has been forecast promising smaller dishes with digital services but apparently the people making these forecasts had neglected to check with the satellite designers to find out whether the satellite transponder electronics could in fact handle the "extra load" that digital produces. Analogue signals have high peak powers but in comparison to digital, lower average power. Every aspect of a satellite transponder (including the power supply to run it) is based upon "average loads." If a digital transponder is operated at the same average power level as the same transponder would operate at for peak analogue levels, the transponder will basically collapse from overload. You can run a horse at a gallop for short periods of time but not continuously. Analogue peaks are for short periods of time; digital has no peaks, just a higher average level. Apparently this was overlooked by those who were forecasting smaller dishes for digital service.

It will be possible to redesign transponder electronics to allow higher average (as opposed to higher peak) power levels, but such changes will not take place until the present generation of satellites is replaced. What we must live with today (and up through the next decade)



# PANORAMIC SATELLITE METRE

## MC10-SAT

AU\$1599 (TAX-EX)

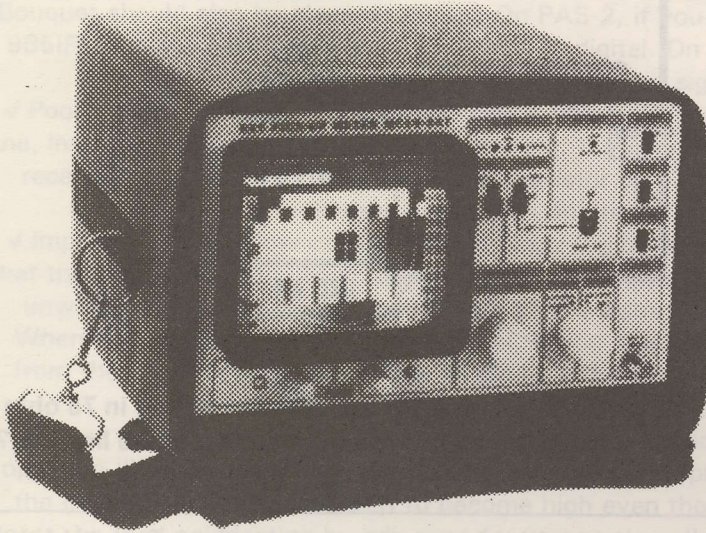

A PERIFELEC  
PRODUCT

- SATELLITE POINTER AND FIELD INDICATOR WITH RECEPTION ON 14cm (5.5") SCREEN
- FREQUENCIES FROM 950 TO 2150 MHz
- DISPLAY OF FULL-BAND AND EXPANDED SPECTRUMS ANALYSER
- DISPLAY OF PICTURE OF SELECTED CHANNEL
- POSITIVE (Ku Band) AND NEGATIVE (C Band) VIDEO DEMODULATION
- MEASUREMENT OF SIGNAL RECEPTION STRENGTH BY WHITE BAR SUPERIMPOSED ON THE PICTURE AND PROPORTIONAL IN LENGTH TO THE SIGNAL IN STRENGTH
- RANGE OF MEASUREMENT OF SIGNAL STRENGTH BY WHITE BAR SUPERIMPOSED ON THE PICTURE AND PROPORTIONAL IN LENGTH TO THE SIGNAL STRENGTH
- RANGE OF MEASUREMENT OF SIGNAL STRENGTH FROM 50 TO 90 dB $\mu$ V
- POWER SUPPLY TO LNB IN 14 OR 18 VOLTS AND 22 KHz
- BATTERY LIFE : ABOUT 1 HOUR
- WEIGHT : 5.1Kg

THE MC10-SAT SATELLITE FIELD STRENGTH METER IS NOW CONSIDERED AS THE ESSENTIAL TOOL FOR ADJUSTING SATELLITE RECEPTION DISHES. THE VISUALISATION OF THE SPECTRUM AND THE PICTURE ALLOWS THE CARRYING OUT OF ALL THE NECESSARY ADJUSTMENTS WITH THIS ONE INSTRUMENT.

**FREQUENCY RANGE :** from 950 to 2150 MHz  
**TUNING:** Multiturn potentiometer  
**INPUT IMPEDANCE :** 75 Ohms  
**INPUT CONNECTOR :** F-TYPE  
**INPUT ATTENUATOR :** 0.10 & 20 dB USING 3 POSITION SWITCH

**SIGNAL STRENGTH :**

- **INDICATION :** by a white bar superimposed on the picture, its length being proportional to the strength of the received signal, and also by audio indicator
- **READING :** on the scale from 0 to 70 dB $\mu$ V
- **MEASUREMENT RANGE :** from 50 to 90 dB $\mu$ V

**LNB POWER SUPPLY :** 14 or 18 V and 22 KHz by switch

**DISPLAY ON 5.5" CATHODE TUBE**

- **SPECTRUM :**
- Full band spectrum (FROM 950 TO 2150 MHz)

- Expanded Spectrum with visualisation of the counter-polarisations

**- PICTURE :**

- positive video polarity (Ku Band) or negative video polarity (C Band)
- Picture of selected channel only
- Picture of selected channel with signal strength indication

**POWER SUPPLY :** 12V, 3 AH battery

**CONSUMPTION :** 1.2 A (without LNB)

**BATTERY LIFE :** about 1 hour

**CHARGING TIME :** about 4 hours

**DIMENSIONS :** 240 x 140 x 270mm

**WEIGHT :** 5.1Kg

**ACCESSORIES INCLUDED :** Measurement cord, AC mains adaptor, charging lead for car cigar-lighter, case.

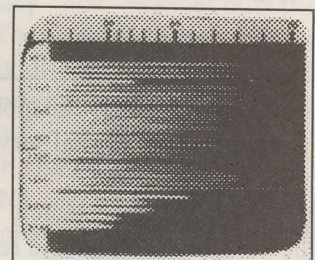

FULL BAND SPECTRUM

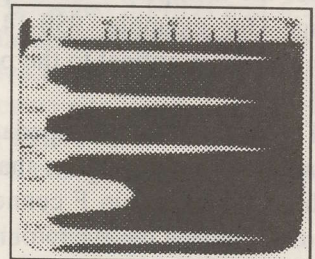

EXPANDED SPECTRUM

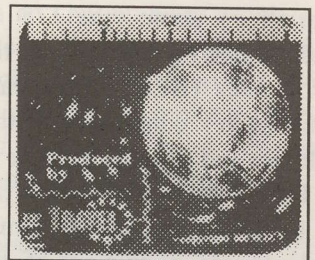

DEMODULATED PICTURE



PICTURE + MEASUREMENT

**OPAC PTY. LTD.** TEL 61-2-584 1233 FAX 61-2-584 1452

99-105 BOUNDARY ROAD, PEAKHURST NSW 2210 AUSTRALIA



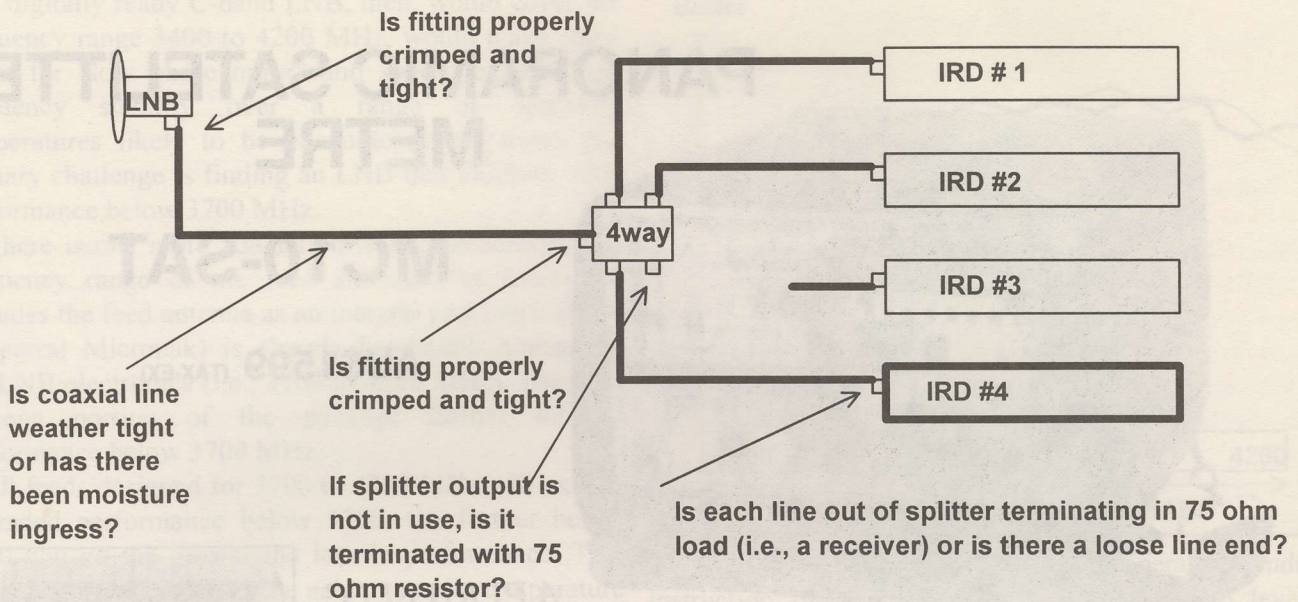

are analogue format transponders being used (because they are there) for digital service.

**The Input Impedance Match**

The "F" connector on the rear of the digital IRD says it is for the IF input. And it specifies the input frequency range (for example, 950-1450). The integrity of this connection is critical to the performance of many digital IRDs.

The specified input impedance at the F connector is 75 ohms. You might expect that if you are using 75 ohm cable, and a 75 ohm F connector to plug into this jack, you will indeed have a 75 ohm connection. Guess again.

Experience to date suggests that any mismatch (variation) from the 75 ohm impedance of the interconnecting cable from the LNB can cause high bit error rates (BER) to appear. You can create similar "mismatch" conditions with improper use of signal splitters and/or improper use of line amplifiers.

Proper digital operation involves accuracy of timing by the transmission path components. If some part of the path causes a portion of the incoming signal to be

delayed in time at the receiver, the information that is delayed finally arrives at the receiver simultaneous to later transmitted information. Now the poor receiver is confused: Which is the real timing? The signal that has been delayed by faulty components in the system or the signal that got through "on time?"

When the IRD is confused the bit error rate escalates. When the BER exceeds the software parameters built into the system the picture and audio at the output of the receiver stop because the receiver believes the BER has climbed to a dangerously high level.

A poor impedance match at the input to the receiver, a poor quality signal splitter can cause all of this to occur. There can be other causes:

1) Degraded transmission line from LNB to receiver (a line that has taken on moisture and begun to "rot" will certainly cause impedance matching problems)

2) An "F" connector poorly installed (or selected as there are some very poor quality connectors in the marketplace). A common fault occurs when the crimp tool that binds the outer shell to the shield of the cable is not properly used (or is replaced with a pair of pliers!).

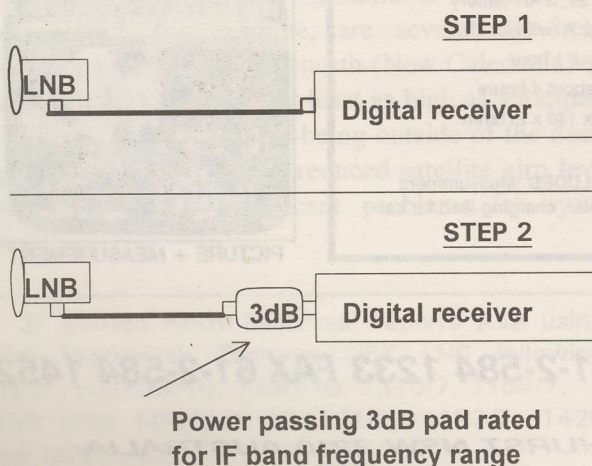

**FIRST STEPS TO CORRECTING HIGH BERs**

While the problem could be LNB related (too high a noise figure, too much phase noise) or feed related (cross pole signals from opposite side), first eliminate receiver "match" problems.

**STEP 1:** Disconnect everything else from the LNB input to receiver line (any splitters, power inserters) and connect the receiver L band input directly to the LNB. If this cures the BER problem, add back one splitter, jumper line at a time while monitoring the BER until you isolate the offending part/connection.

**STEP 2:** If this does not correct the high BER, place a 3(6)dB in-line power passing pad at the input to the receiver (as close as possible), thereby forcing a "match" to the receiver input.



### THE MOST COMMON CAUSES OF HIGH BIT-ERROR-RATES

- ✓ Poor C/NR (Carrier to noise ratio); i.e., you need a bigger dish, lower LNB noise figure or both. On As2 if your system has clean pictures on Chinese transmissions at Hz1430 or 1310 (IF), then the European Bouquet should also be clean on digital. On PAS-2, if you have clean analogue from The Value Channel (VT 985IF) then the NBC feeds should be clean in digital. On PowerVu feeds (PAS-2, 1249Hz, 1002Vt) check your installer menu to determine if signal level is in range of 60-65.
- ✓ Poor impedance matching between digital IRD and transmission line system from LNB (caused by a poor line, improper splitters, fittings, jumper cables). If you are using signal splitters, either terminate all ports into receivers or place a 75 ohm terminating resistor on unused ports. Never leave a port "open." Never use power-pass all port splitters. See detail page 10, bottom.
- ✓ Improper use of a low quality line amplifier. Digital receivers do not require high input signal levels, only that the inputs be clean. Too much signal (i.e., an input that has been amplified by a line amplifier) is at best unwise and the line amplifier can easily create distortion products that "dirty" the input to the receiver. When in doubt, remove the line amplifier. If you must have it for analogue signals on the same input line from the LNB, reconfigure the line amplifier and splitters to allow the digital receiver(s) to be fed straight from the LNB while the line amplifier is used only on the analogue service channels.
- ✓ Cross polarisation ingress. A feed that has not been adjusted properly to totally "null" (cancel out) the opposite (linear) polarisation will allow unwanted signal products into the IRD. These extra signals confuse the IRD and will cause the BER to become high even though the digital signal is of adequate signal level. Reset the feed polarisation by adjusting for cross pole null, not maximum signal on the desired side. The two adjustment points may not be the same (SF#21, p.22).
- ✓ Terrestrial interference. Any strong microwave frequency range signal located in the physical vicinity of the receive site has the ability to overload (i.e., saturate with too much signal) the LNB. An overloaded LNB may still function (after a fashion) with analogue signals but can develop distortion products (i.e., new signals generated within the LNB by the very strong microwave signal) which interfere with the more vulnerable digital service signals. Terrestrial microwave "in-band" (i.e., actually operating between 3.[4][7] and 4.2 GHz) can be seen on a spectrum analyser; signals from radar or other terrestrial services outside of the analyser displayed spectrum are more difficult to locate. Most radar systems have a repetition rate created by their 360 degree coverage antennas; as the antenna rotates towards your receive site (such as every 15 seconds) the interference hits and then abates, to hit again 15 seconds later. Filters for both types of microwave interference are available at reasonable pricing (see Communications & Energy Corp, p. 21 here).

#### HIGH BERs THAT COME AND GO RANDOMLY

- ✓ A possible sign of an LNB problem. If the LNB local oscillator (LO) is unstable over time, and it drifts beyond the capture range of the IRD (receiver), at the edges of the capture range (AFC) the BER can climb dramatically. If you have high BER followed by a signal outage, you could have an LNB stability problem. Maintain a log of environmental conditions against high BER or outages: It only occurs when the temperature drops below (or rises above) a certain point? It only happens when it rains? It only happens when the wind blows over 20mph from the east? Solutions: Temperature is likely the LNB; rain sounds like moisture into a fitting; wind from one direction sounds like your dish is not properly boresighted and with a wind from one direction may move just enough to lose the signal margin required for proper digital reception.

#### IF EVERYTHING ELSE FAILS-

- ✓ **THEN** replace the LNB. The older the LNB, and the higher its rated noise temperature the more likely you will have a dramatic improvement in bit error rate with a replacement (a 55 or 75 degree K LNB is ready for replacement!). But a replacement LNB will not correct a high BER if you have other installation problems as described here (such as unterminated splitter ports or a poor input impedance match to the IRD).

#### Parts That Work

Signal splitters (used to create 2, 4 or more connections to a single LNB for multiple receivers) that are capable of working properly over the L-band (950 to 1450/1750/2050/2150 MHz region) are not as easy to locate as you might suspect. One model series to avoid: A Taiwanese made unit without a brand name (packed in a black and white box and labelled "High Technology SMATV Broadcasting Equipment"). If the unit is a PD-102 (2-way), PD-103 (3-way) or PD-104 (4-way), we suggest you not use them. Equally, a unknown origin model "#SA20" unit labelled "High Gain in-Line amplifier" has very poor noise figure and overload

characteristics. Any signal splitter that is marked "all ports power pass" is to be avoided; use only those which have a single power pass (output) port, rated to at least 2000 MHz top end.

Any MATV parts equipped with something other than a true "F" fitting should never be used in a dish installation. And parts rated to only 800/900 MHz, for MATV, are also not usable above 950 MHz.

Acceptable: CHY SA-910LA in-line amplifier, CHY SS-202 and SS-204 splitters and Oarsman OM-AT3 (6, 10) in line power passing attenuators.



## THE PANASAT IRD520 MPEG-2 DVB COMPLIANT RECEIVER

The Panasat model IRD520 DVB Compliant MPEG-2 receiver was created for sale in Africa to support the PAS-4 Ku-band Multichoice DTH service established there. The design originates from the same original research which produced the Pace DGT-400 (Galaxy), and DVR-500 (NBC Asia and Multichoice Africa). Common to the DGT-400 and IRD520 are their reliance on the Dutch based Irdeto conditional access (CA) technology. It is the CA expertise which drives the pay-to-view digital DTH subscription television services such as Galaxy and Multichoice.

SF reported on the first production of Panasat receivers in issue 19 (p. 10). The report related the receivers worked well enough but were in short supply because of a South African factory fire in December.

The IRD520 is designed to function in an Irdeto conditional access environment. The receiver is shipped to the user with a CA module installed (whereas Pace DVR-500 receivers shipped to cable TV affiliates by NBC have no module).

The first quantity of IRD520s to appear in the Pacific/Asia marketplace have been imported by OPAC (1) and Jacob Keness advises these receivers are exactly as Multichoice users receive in (South) Africa.

### The Complete Package

Multichoice DTH subscribers have access to a range (16+) Ku band delivered programme channels. A typical Multichoice installation is a 1.2m range dish equipped with something they call an "Universal LNB." This is a

dual LO (local oscillator) LNB that functions from 11550 MHz-upward and 10700-upward. Neither of these Ku bands are in use in the Pacific at this time. A switching voltage generated by the IRD520 tells the LNB which LO is to function as various programme channels are selected.

This receiver covers an IF range of 950-2050 MHz and is designed to respond only to QPSK (normal MPEG-2) data streams. It will not demodulate analogue or other format signals.

Unlike other MPEG-2 receivers available to date, the IRD520 is very much consumer oriented in features. The manual is superbly written (although pointedly around the Multichoice programming package) for the non-technical consumer and in fact reads very much like a well researched consumer high end VCR set of instructions. The input side is a straight forward F connector for the LNB line while on the output side there are twin SCART ports for feeding directly to a VCR and/or TV receiver equipped for such plugs. There are also stand alone right and left audio output jacks for a sound system (Multichoice includes several radio-only programme channels). It is unfortunate that output video is not brought out alone on a female chassis jack to allow dipping into the video stream without having to use the SCART cords (although the cords are included with the receiver). An RF output into the UHF television band is also included.

In Multichoice use the installer aligns the dish (the installation menu provides a pair of on-screen guides which we found quite useless), enters the reception parameters (RF input frequency, polarisation, FEC and symbol rate) and inserts something they call a "Smart Card" into a front panel slot. The Smart Card is the missing link in the conditional access network and in theory is only required when you are attempting to access CA restricted transmissions. Each card has a unique number and it is through the Smart Card ID number that Multichoice subscribers are able to gain authorisation for the various services on offer.

### As A Free To Air Receiver

OPAC brought in the IRD520 unit to satisfy a growing demand for access to the European Bouquet (EBB) services on AsiaSat 2. For these services you enter in:

1/ OPAC, 99-105 Boundary Road, Peakhurst NSW 2210, Australia; tel 61-2-584-1233, fax 61-2-584-1452. Also available through Telsat Communications (NZ tel 64-6-356-2749) and others (see p.4).

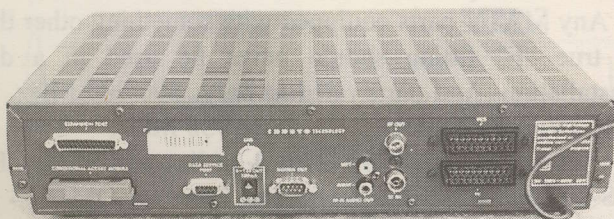



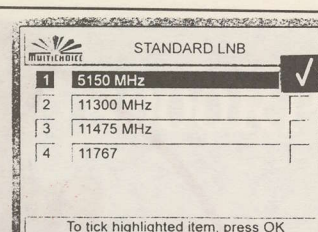
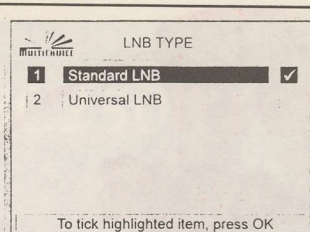
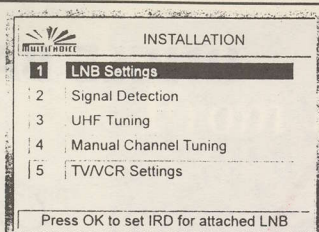
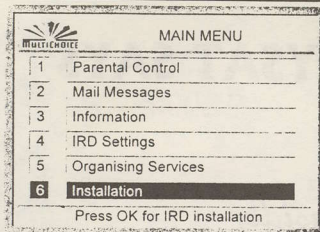

1) Installation menu ( pin #9949); 2) LNB settings; 3) standard LNB; 4) 5150 MHz (may also need on line 4)

- 1) RF frequency - 4000 MHz
- 2) Symbol rate - 28125
- 3) Polarisation - Horizontal (may not be mandatory)
- 4) FEC - 3/4

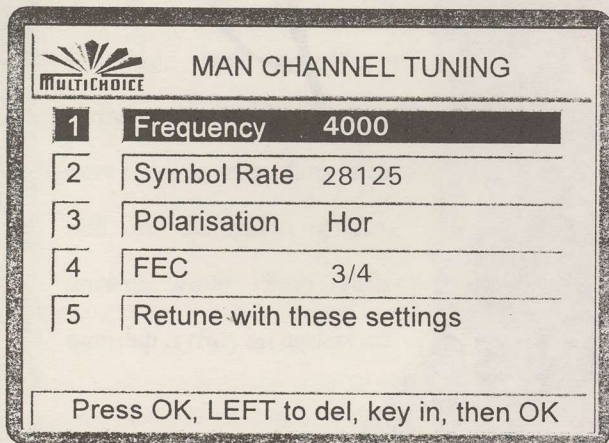

Assuming you have adequate As2 horizontal signal level coming from your LNB, the receiver should immediately (0 to 10 seconds) take off with Deutsche Welle appearing on programme channel 1. You can judge the suitability of the As2 signal for this purpose by checking with an analogue receiver the quality of CCTV on horizontal IF 1180. If this picture is P4 or better, you should have more than adequate carrier to noise on the companion EBB service on the same polarity.

The IRD520 will also work on the NBC feeds on PAS-2 for as long as they remain "open key" (i.e., the conditional access routine is not turned on). For the appropriate installation numbers, see page 27 here.

#### Problems?

OPAC brought in sufficient receivers for a number of different installation scenarios to be created. Most of these were peculiar to the installation procedures employed by the early users and we will attempt to summarise those we have heard about here.

1) The receiver enters the search routine (screen says "searching for default frequency" followed by "searching for signal on 4000 MHz" sometimes followed by "No Signal") and no reception follows.

a) First confirm CCTV-4 is at P4 or better level; there is little point in chasing the MPEG-2 signal if you do not have an adequate carrier to noise ratio and CCTV-4 is your indicator.

b) If you have an LNB input line that includes any splitters, line amplifiers or power inserters, temporarily

remove them from the line so the LNB goes directly to the receiver's IF input without passing through any other equipment (see page 6, here).

Each time you make a change in the system, we suggest you push the "exit/exit/exit" button on the remote control to completely exit the menu. Then start over re-entering the installation menu (the pin number is 9949), going to the Manual Channel Tuning line and if you still have 4000/28125/Hor/3-4 entered move the blue bar to the 5 position ("Retune with these settings") and push "OK." Commit this paragraph to memory; you will use it over and over again between every new instruction entry made with the remote control.

c) Some users have been unable to access EBB with the receiver set at 4000 MHz. This is an LNB (local oscillator) problem; your LNB LO is off by just enough megahertz to "slide" the input frequency either side of the normal 4000 MHz. Solution? Re-enter a new input frequency (trying a range between 3990 and 4015 in 5 MHz steps; 3990, 3995, 4000, 4005, 4010, 4015) until you hit the right one. Remember the paragraph above - exit totally after each change and then restart again.

d) The conditional access module. Steffen Holzt (New Caledonia) ran into this one; he was not alone. He tried sliding the input frequency and got no results. Then he turned the receiver off (unplugging it as there is no total power on-off switch), waited 20 seconds (per the manual) and removed the CA module from the back. Then he repowered the receiver, went back through the exit and re-entry routine and there was EBB on 4000 MHz as advertised.

We had a similar experience at SF and following Steffen's instructions instantly made ours work as well with the CA removed. Then we powered down again, put the CA module back in and repowered. No EBB. So we unpowered a second time and back through the routine - and up came EBB. Jacob Keness advises this is not a common symptom.

The IRD520 manual includes four pages of fine print "Troubleshooting" symptoms and explanations. Most of these relate to specific Multichoice CA service "defaults" rather than true equipment (soft or hardware) problems and we would like to believe the unit is not prone to such a range of problems in normal use.

Continued, page 16





## UNCLE BAYSAT SAYS

*Consider  
the power  
of the letter*

*P*

*Paraclipse*

*Patriot*

*Palcom*

*Pace*

*Panasat*

---

*P* - perfect pics!

**YES!**

We accept VISA  
& Mastercard  
with no surcharge

**BAY SATELLITE TV LTD**

PO BOX 14050 • Hastings • New Zealand • Tel toll free 0800 BAYSAT  
International 64-6-878-9081 • Fax 64-6-878-5944 (0800-229-728)

e-mail [john@baysat.co.nz](mailto:john@baysat.co.nz)



## SL-8000RP

4500 years ago, the Egyptians were so far advanced in building technology that the pyramids were considered to be one of the Seven Wonders of the World. Today, still standing, these magnificent shrines to the achievements of man leave us marvelling at the skill and dedication of these ancient people. Fine craftsmanship is truly an ageless art.

Palcom receivers reflect skills and craftsmanship based on the same traditional values. The flagship of the Palcom range, the SL-8000RP is another marvel of technology.

## From BC2500 to SL-8000RP

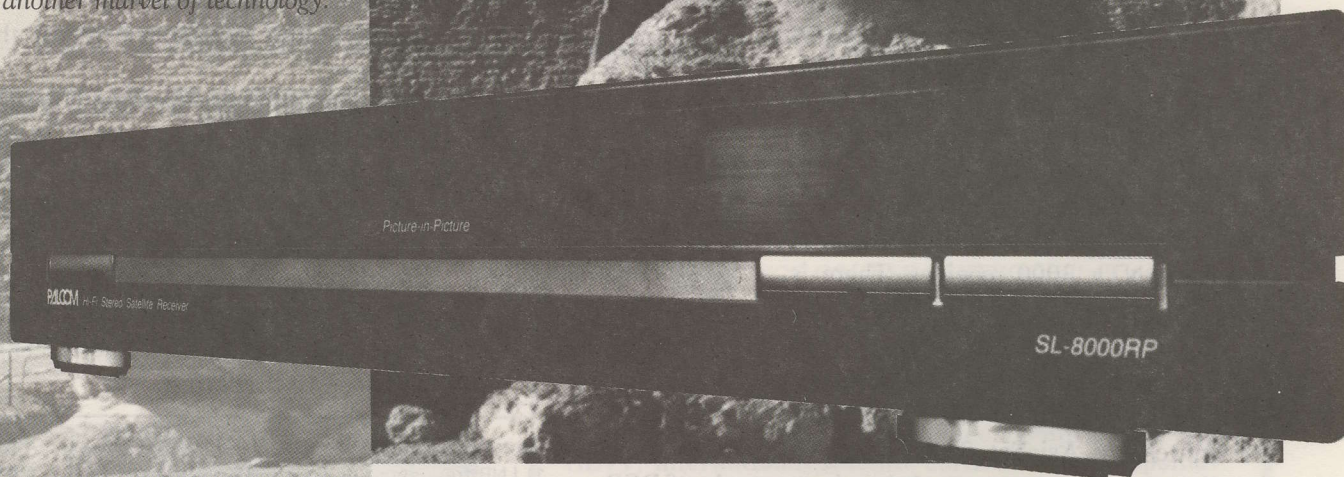

Its unique moving Picture-in-Picture feature permits the viewing of two channels at the same time (on one TV or two) or watching one channel whilst recording another. Mix images from satellite and terrestrial TV, satellite TV with VCR playback or satellite TV and security camera output with a choice of picture size for each image source.

The weakest signals may be viewed using the Palcom low threshold tuning facility producing improved video and audio performance.

A built-in antenna positioner provides access to all current satellites

500 Channels • 2 Tuners • 3 IF Inputs • Weak signal Video and Audio processing • HiFi 1600 • Stereo Audio processing (surround) • On Screen Display in 6 languages • Channel Naming • Satellite Naming • LNB Naming • Decoder Naming • 16 Local Oscillator presets (adjustable) • 22kHz Tone Switching • Global and Fine Ferro/Skew adjustment • Alphanumeric Channel List • Favourite Channel Function • 16 Preset External Decoder configurations • Internal VideoCrypt ready • Timer / Priority switching for TV and VCR

with software by....

# PALCOM

State of the Art Simplicity



e) Frustration sequence. We disconnected the IRD520 from the LNB to make a cable swap and replugged in; no reception. "Exit/exit/exit" and still nothing with re-entry. Unplug the receiver and start over again. Still no reception (screen says "No signal"). Push the large red button on the remote control (at top, used for switching from standby to normal; it was in normal at the time and this should turn the unit to standby). Bingo, it did not go to standby, but rather brought up EBB instantly. We have no explanation for this, and it has happened several times to us.

There are so many variables that each user will have his own sequence to report. First and most important, there must be a clean input signal to the IRD. Steffen Holzt switched from a 3.6m dish to a 2.5m dish and while CCTV-4 was still "almost P4" on the smaller dish, he could not initially bring EBB up on the smaller antenna. With a spectrum analyser he measured 7.5dB C/NR on CCTV-4. So the margin is close and under at least Steffen's circumstances a tiny reduction in C/NR was enough to make the unit stop functioning.

Following his experience we attempted to determine the C/NR threshold for this receiver and came up with mixed results. On the EBB service we found we had to have 2dB better C/NR for performance than we did with the NBC service on PAS-2. In other words, the characteristics of the transmitted signal have a dramatic impact on where threshold occurs and at least for NBC and this receiver, it works better with lower signal levels on NBC than it does with EBB.

There has been a parallel observation reported by several users of the far more expensive NTL 3000 receiver. There is universal agreement that MPEG service signals transmitted through PAS-2 produce better bit error rates (BER) for equivalent C/NR than signals transmitted by AsiaSat 2. In other words, something peculiar to As2 seems to result in a lower grade of BER when signal levels are equal between the two satellites. If this observation bears out with further testing, it simply means As2 MPEG-2 services will require larger dishes to produce suitable reception than will PAS-2 MPEG-2 services. Why? A number of possibilities including "noise floor" (satellite uplink input threshold)

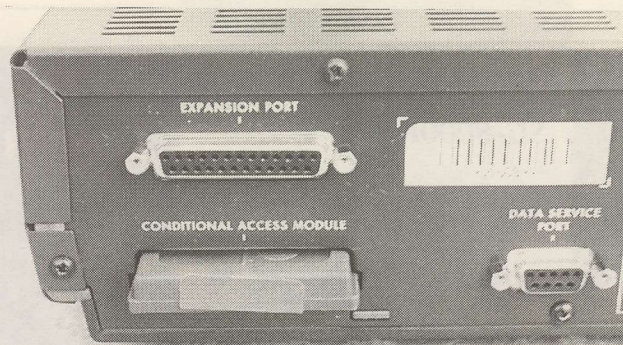

The CA module (lower left) may have to be removed for FTA MPEG-2 to work

problems or "linearity" problems with As2. A transponder that is not properly "linear" should have a jagged appearing passband response when viewed on a spectrum analyser, indicating portions of the transponder bandwidth have different "gain" characteristics. However, the way the MPEG service is transmitted at the uplink can also create this "jagged" appearing transponder display so jumping to conclusions based upon analyser displays may not be accurate.

#### Performance

The IRD520 video and audio quality is excellent; as good as the DVR-500 or NTL-3000. Anyone who has operated the DVR-500 or DGT-400 will have no problem navigating through the installation commands. This is a true consumer receiver but given that the majority of its design features are in place for subscribers to a CA service (Multichoice at that; not available in this part of the world), the true benefits of the design may not be totally useful to the average viewer of the EBB services.

Because this is the first FTA MPEG-2 DVB Compliant receiver into the Pacific and Asia, available to anyone willing to purchase, the demand is high and pricing can be expected to be erratic for several months. Fear not - competition units are coming and pricing will fall as we have more choices in equipment. This is a satisfactory first effort.

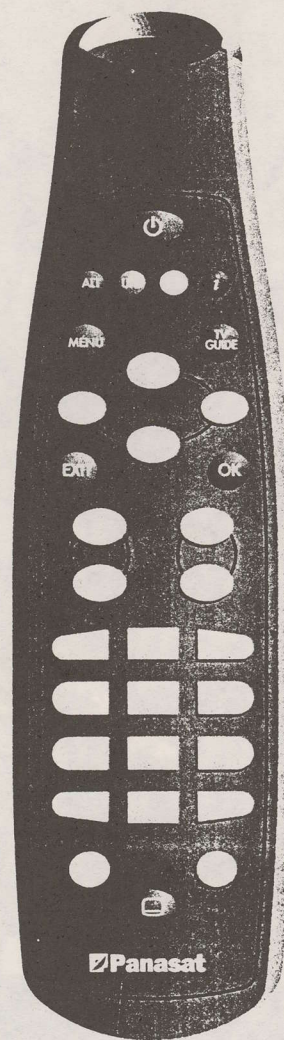

- To tune in the non-CA services of Galaxy with the IRD520:
- 1) LNB frequency: go to line 4 and press OK, then type 11300 followed by exit/exit/exit/exit/exit/exit
  - 2) Go to manual tuning and enter:
    - Frequency - 12438
    - Symbol rate - 29473
    - Polarisation - Horizontal (for 18V, standard LNB)
    - FEC - 3/4

Without a Smart Card you will receive Value Channel on 10, Preview Channel on 13 and all of the radio services including BBC, VOA. For programme guide information, push the "i" key.  
(Instructions courtesy Jacob Keness, OPAC Pty Ltd.)



# SATELLITE TV TECHNOLOGY CORRESPONDENCE COURSE

The official technician certification course of the **SPACE—Pacific satellite trade association**

**THE SATELLITE TV TECHNOLOGY CORRESPONDENCE COURSE** is a complete home/office study program that has been expressly developed for students and professionals who wish to expand their knowledge and technical skills. The course consists of the *Satellite TVRO Handbook* and *Satellite TV Technology Overview* videotape, supplementary text materials on the latest technical developments in the Asia/Pacific Region, four take-at-home exams, a report card, and a certificate upon course completion. Students are able to proceed at their own pace and receive clarification from the course leader concerning specific course topics or ask questions on related topics.

**THE SATELLITE TV TECHNOLOGY CORRESPONDENCE COURSE** is taught by Mark Long, Founding Publisher of the *World Satellite Almanac*. Each of the four major course exams are mailed to registered students upon receipt of their written request for the exam materials. Completed exams are returned to the course leader for grading and suggestions for further study to clarify those points on each exam which the student may



CORRESPONDENCE COURSE VIDEOTAPE (ABOVE): **PART ONE: THE SPACE SEGMENT:** Orbits & Orbital Assignments; Frequencies; Satellite Frequency Bands S/C/Ku/Ka; FSS vs BSS Satellite Frequency Assignments; Satellite Transponders; Satellite Polarization Formats; Satellite Communication Subsystems; and Interpreting Satellite Coverage Maps. **PART TWO: THE EARTH SEGMENT:** Antennas & Feedhorns; LNBs; Receivers and IRDs. **PART THREE: VIDEO AND AUDIO PROCESSING:** Video Standards - NTSC, Pal And Secam; HDTV; Video Encryption; Digital Video Compression; Digitizing Video; MPEG & MPEG DVB; MPEG Compression Techniques; MPEG Data Rates; Transmitting MPEG Via Satellite. **PART FOUR: INSTALLING SATELLITE RECEIVING SYSTEMS:** Antenna & Feedhorn Alignment; Installing Digital Receiving Systems. 60 minutes, PAL-VHS.

not have fully mastered. Upon successful completion of the four major exams, each student will be awarded a certificate of course completion.

## THE SATELLITE TVRO HANDBOOK

written & compiled by Mark Long

Founding Publisher of The **WORLD SATELLITE ALMANAC**

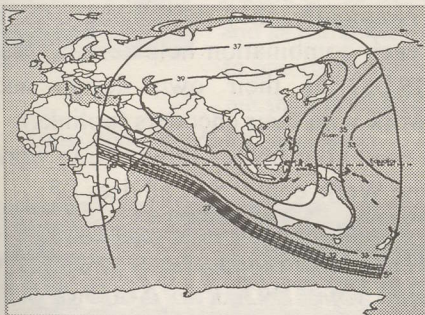

- ✓ INTERPRETING SATELLITE FOOTPRINTS
- ✓ SATELLITE FREQUENCY ASSIGNMENTS
- ✓ VIDEO & HDTV STANDARDS
- ✓ MPEG DIGITAL COMPRESSION
- ✓ TVRO SYSTEM DESIGN
- ✓ INSTALLATION PROCEDURES
- ✓ TRACKING
- ✓ INCLINED ORBIT SATELLITES
- ✓ SMATV SYSTEM OVERVIEW
- ✓ SOLAR & RAIN OUTAGES
- ✓ TERMINOLOGY GLOSSARY

THE OFFICIAL  
TECHNICIAN  
CERTIFICATION  
TEXTBOOK OF  
**SPACE Pacific**  
Satellite  
Program  
Access  
Committee  
The trade association of  
private satellite-direct systems  
in the Pacific Ocean Region

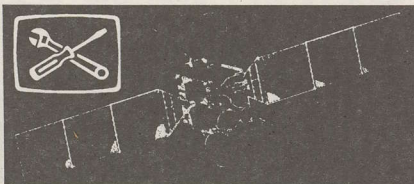

Available from **SPACE—Pacific** for NZ\$ 650, A\$600, or US\$ 394, **THE SATELLITE TV TECHNOLOGY CORRESPONDENCE COURSE** includes the basic course textbook, a one-hour course videotape, supplementary text and graphic materials, exams, a report card, a certificate upon successful completion of the course and all shipping and handling fees. Contact: **SPACE—Pacific**, PO Box 30, Mangonui, Far North, New Zealand. Fax: 64-9-406-1083

CORRESPONDENCE COURSE TEXTBOOK (Left): A comprehensive introduction to all aspects of satellite video and audio technology covering basic satellite terminology and the interpretation of satellite coverage maps; satellite subsystem overview; satellite telecommunication frequency assignments; video transmission and encryption standards, digital video compression and HDTV; international satellite earth station component guide; how to install satellite TV receive only (TVRO) systems, modified polar mount alignment; inclined orbit satellite tracking guide, SMATV system design; the effects of solar outages and rain fades on satellite system design, and a complete lexicon of satellite terminology. The official technician certification course textbook of **SPACE Pacific**. 212 pages illustrated.



## THE SCIENTIFIC-ATLANTA D9223 POWERVU COMPLIANT RECEIVER

### NO - It Will Not

In SF#22 we reported on early attempts to make the Scientific-Atlanta D9223 receiver function with DVB Compliant MPEG-2 transmissions such as the European Bouquet (EBB) programme channels on As2. You will recall that not only would the receiver not lockup on these channels but we had been unable to locate anyone at Scientific-Atlanta who could advise us whether with re-entry of software the receivers would accept DVB Compliant services.

Here are the answers, provided June 28th by an engineer at the home office in Atlanta.

1) The S-A D9223 is MPEG-2 DVB Compliant. That does not mean it will work with any and every MPEG-2 DVB Compliant service transmitted. DVB Compliant covers a "range of specifications within which individual programmers (uplinks) can vary their system information (SI) or protocols without violating the 'spirit' of DVB Compliant."

2) The S-A PowerVu system "includes digital video encoders, multiplexers, modulators ... conditional access capabilities, as well as a network management system."

3) In "interoperability tests" conducted during May by Intelsat an S-A PowerVu IRD was found to be capable of functioning with MPEG-2 encoded uplinks designed by manufacturers Tiernan, Philips (1), DMV (NTL; 1), Divicom, TV/Com and STS.

However, "interoperable" in these tests was based upon each uplinker sharing at an engineering level the detailed parameters of their encoded signal (like providing the combination to a safe). In effect, each company participating said, "Here is our safe combination, now will your receiver unlock our safe?"

So if the D9223 is "interoperable" with Philips (NBC) and DMV/NTL (EBB), why won't this IRD tune-in these free to air MPEG-2 DVB Compliant signals?

Within the broad framework of MPEG-2 there is a "range" of software commands. An example:

To open this safe:

1) **First, turn the knob clockwise three complete rotations passing 0 each time then stopping at 42.**

These are very specific instructions and one assumes

---

1/ NBC on PAS-2, 1057Hz is Philips while EBB on As2 (1150Hz) is DMV(NTL).

turning the knob two or four times, or stopping at 41, will not cause the "tumblers to fall."

To be "DVB Compliant" a manufacturer must only follow the "intent" or "guidelines" of the standard. In this example, the guideline might be rewritten to read:

**2) First, turn the knob clockwise more than one time passing 0 each time and then stopping at 42.**

So S-A sets up their first "tumbler" to fall if the knob is turned 3 times past 0, Philips sets their formula up to require passing 0 twice, DMV/NTL sets theirs to pass 0 four times. All maintain the "spirit" of DVB Compliance, and if you know the particular number codes their combination has adopted through the entire DVB (system information) routine, you could in fact make any receiver work with most any encoding scheme.

Within the system information stream there are four key number sets and several lesser sets. Each number (i.e., instruction) must be spot on or the receiver will not decode the video/audio information stream. There is a video PID (packet identification number), an audio PID, a PCR (programme clock reference) PID and a PMT PID (flexible packet based multiplex number).

Get one number wrong and the safe will not open. Get any number out of sequence and the safe will not open. S-A writes their own (PowerVu) "combinations," Philips writes their own, DMV/NTL writes their own. Nominally, they do not share these numbers because each combination helps ensure that only decoders (IRDs) of their own design and manufacture will work with their encoders (uplinks).

So, you say you want your D9223 PowerVu to work with EBB (Deutsche Welle et al)? S-A advises SF:

*"If you will obtain the audio and video PID(s), the PCR PID and PMT PID from the uplinker and supply these numbers with your D9223 to S-A, we will endeavour to 'convert' your IRD to this service."* There is a fee for this conversion (not detailed) and one "Oh, by the way ... ."

*"If the D9223 can be 'converted' to the EBB 'combination', the IRD will work only for a single programme service."* Translation? Although EBB has five video programme channels (Deutsche Welle, RTVE, TV5, MCM and RAI Uno), the S-A conversion will only allow the receiver to tune one of these services. No programme changing in the field. Pick the one you want and that is what you will get.

*Maybe.*





# AV-COMM SATELLITE TV EQUIPMENT



## WORLD SATELLITE TV AND SCRAMBLING

Cat # B1020

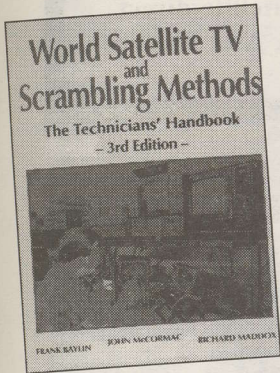

Known as "the technicians' handbook", this text is a must buy for technicians, satellite professionals, and enthusiasts. The design, operation, and repair of satellite antennas, feeds, LNBS and receivers are examined in detail. An in depth study of scrambling methods, and broadcast formats is the backdrop to a discussion of all current American and European satellite TV technologies, including the

Videocypher II, Oak Orion, Filmnet, UK Sky Channel, EuroCypher, D2MAC, BSB and Teleclub Payview III. Circuit and block diagrams of all components are presented and clearly explained throughout the book.....\$79

## WIRELESS CABLE & SMATV

Cat # B1011



A comprehensive study of the new broadcast method, Wireless Cable, and the closely related field of satellite master antenna TV systems (SMATV). Three chapters are dedicated to details of the site survey, planning and design phases of a private cable system. Off air and satellite headends and all components from antennas to processing and mixing electronics are studied in detail. Ideal for those

considering an MMDS installation. ....\$89

## THE WIRELESS PRIMER

Cat # B1021

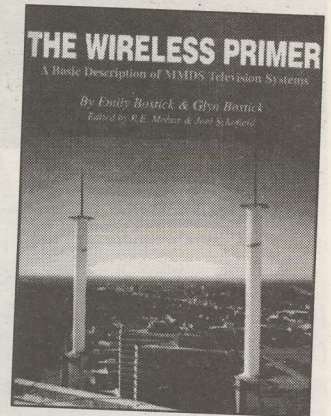

A 76 page complete description of MMDS television systems. This first edition, published in 1995, contains thirteen comprehensive chapters covering all aspects of system design, and shows actual on-air configuration of a 31 channel MMDS system. A valuable reference for anyone involved in installation or maintenance of an MMDS system, "The wireless primer" shows how one operator in the USA saved \$100,000 on hardware by following the designs in this book!! .....

\$45

## 1995/96 WORLD SATELLITE YEARLY

Cat # B1013

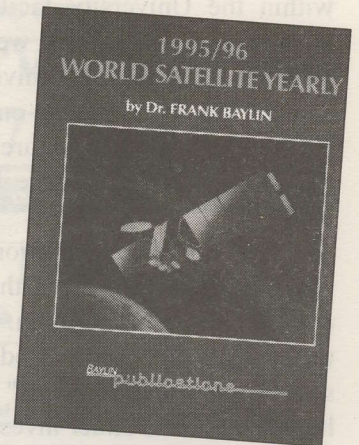

The 768 page 1995/96 World Satellite Yearly contains the latest information about satellites, technology and programming. Features updated chapters on audio and video compression, footprints for satellites launched during 1994 and projected for 1995/96, and worldwide programming assignments. The ultimate reference book on satellite TV footprints, programming and technology. ....\$140

## AV-COMM PTY. LTD.

DIRECT IMPORTER ACN 002 174 473  
PO BOX 225, BALGOWLAH  
NSW 2093 AUSTRALIA

TEL: (02) 9949 7417

FAX: (02) 9949 7095

CUSTOMER BULLETIN BOARD  
(02) 9905 0849

LIGHT YEARS AHEAD OF OUR IMITATORS



✓YES GARRY, Please send me

- 1 x World Satellite TV and Scrambling @ A\$79 Plus \$17 Airmail
- 1 x The Wireless Primer @ A\$45 Plus \$6 Airmail
- 1 x Wireless Cable & SMATV @ A\$89 Plus \$23 Airmail
- 1 x 1995/1996 World Satellite Yearly @ A\$140 Plus \$23 Airmail

Order two or more titles and we'll send your shipment freight FREE!!

Credit card No:

Signature \_\_\_\_\_ Expiry Date: \_\_/\_\_/\_\_

Name: \_\_\_\_\_

Delivery Address: \_\_\_\_\_

P'code: \_\_\_\_\_



a technical and marketing  
advisory

## memo

to the membership from your  
industry trade association

## SPACE Pacific

Satellite  
Programme  
Access  
CommittEe



A trade association for users, designers,  
installers, sellers of private satellite-direct  
systems in the Pacific Ocean & Asia Regions

### SPRSCS '97

The South Pacific Region Satellite & Cable Show for 1997 (SPRSCS '97) will be held at the University of Auckland Tamaki Campus January 21-25 (1997). Invitations to attend will be mailed to SPACE Members (individuals and firms) late in August and general registration to non-members will be available from 1 October. Member or not, you are encouraged to utilise the SPACE information card found on page 30 of this issue to voice your intent regarding attending this year's annual show. A more detailed survey of SPACE members will also be conducted in August.

The facility this year is a repeat of 1996 although some expansion of the rooms available to SPACE within the University facility is planned. Those who attended SPRSCS '96 were enthusiastic about the physical facility at the University, the excellent up-front antenna lot where hands-on lessons could be imparted and the high quality lecture theatres. We will fine tune from the 1996 experience but there will be no major changes.

In the "minor adaptation" department a number of suppliers have requested the opportunity to have their own, private, display room. As the facility rooms allow, they will be accommodated. Suppliers are also suggesting "social events" scheduled in the evening hours and this is under investigation.

The 1996 "Open Public Day," created with the co-operation of Country Music Television and Auckland radio station FM Country was a considerable success



Some of the best lessons learned were in the  
antenna display lot

### SPRSCS '97 - The Specifics

**Dates:** January 21\*-25, 1997

**Location:** University of Auckland, Auckland, New Zealand

**Sponsor:** SPACE (Satellite Programme Access CommittEe)

\* / **Schedule:** January 20/21: Antenna and display set up.

January 21/22: Optional Mark Long tutored SPACE Dealer/Installer Certification Course (see text)

January 23/24: General and special sessions, technical and management

January 25: Open Public Day

**Information:** Use insert card page 30 this issue or contact SPACE fax 64-9-406-1083

## MEMBERSHIP IN SPACE

Membership in SPACE Pacific is open to any individual or firm involved in the "satellite-direct" world in the Pacific and Asia regions. There are four levels of membership covering "Individuals," the "Installer/Dealer," the "Cable/SMATV Operator," and the "Importer/Distributor/Programmer."

All levels receive periodic programme and equipment access updates from SPACE, significant discounts on goods and services from many member firms, and major discounts while attending the annual SPRSCS (industry trade show) each January in Auckland. Members also participate in policy creation forums, have correspondence training courses available. To find out more, contact (fax) 64-9-406-1083 or use information request card, page 30, this issue of SatFACTS. Editorial space within SatFACTS is donated each month to the trade association without cost by the publisher.





Cynthia Dickins, PanAmSat Asia

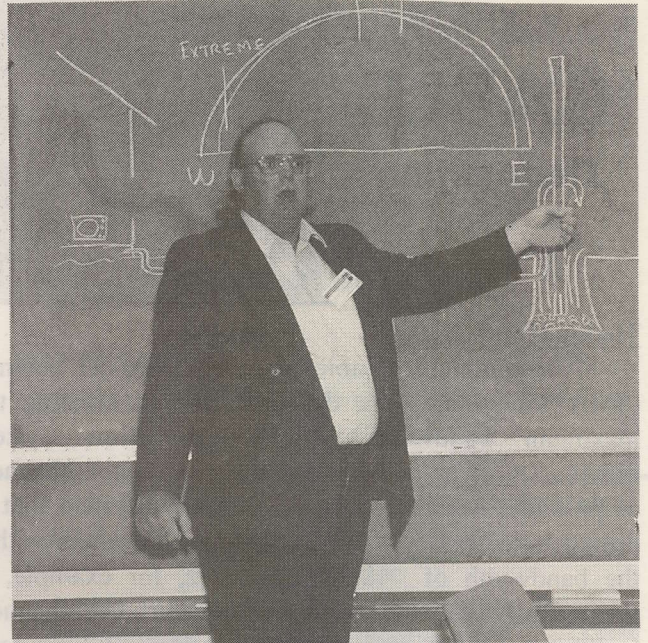

"Dr. Dish" (Tim Alderman)

and some form of this will be repeated. With the greatly expanded programming sources already available (and far more to be available before the show) the attraction of owning a DTH dish is certainly far greater this year than it was last January. One recently completed study forecasts more than 70 programme channels available in New Zealand (not all, perhaps reasonably priced) and more than 90 in favoured regions of Australia by the end of January.

For the 1996 show, we held a special one-day "Basic Technology Day" as day one followed by two days of general sessions. Author and lecturer Mark Long (MLE, Inc., Thailand and Florida) is willing to conduct an intensive two-day Satellite TV Technology Course January 21 and 22 if there are sufficient people who will come in two days early for this special course. This is the same course offered now through SPACE (see page 17, here) and there will be three advantages to taking the course directly from Mark Long rather than through correspondence:

- 1) You will be finished in two days and awarded your course completion certificate before leaving SPRSCS,
- 2) You will benefit from being in a live teaching environment with one-on-one communication with the course leader,
- 3) You will save 10% off the course cost.

Because of the advance scheduling required to arrange this course, it is absolutely imperative that if you have an interest in attending this certification course January 21-22 that you add this information to the SPRSCS '97 request card on page 30 in this issue.

## FILTERS FOR ALL TV SYSTEMS \*YEAR #27!

For Example

Free Catalogs

CABLE TV SYSTEMS			TVRO & PRIVATE CABLE		
					
Channel Deletion	Channel Bandpass	Bandsplit	Low-Cost Deletion	Anti-Radar Bandpass	Block-Band Pre-Select
+ Your special needs			+ Your special needs		

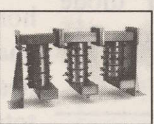
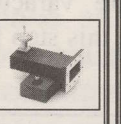
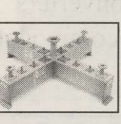
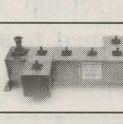
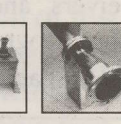
MMDS - "WIRELESS TV"			LPTV - "LOW POWER TV"		
					
Relay Antennas	Channel Combiners	Line Components	Channel Combiners	Transmitter Bandpass	Line Components



Emily Bostick  
President

*Emily Bostick*

Emily & Glyn Bostick -  
\*Continuing a generation of personal service to TV INDUSTRIES WORLDWIDE!

### BOSTICK FILTER DIVISION



7395 Taft Park Drive  
East Syracuse, NY 13057  
Mailing address:  
PO Box 3307  
Syracuse, NY 13220  
Tel: (315) 452-0709  
Fax: (315) 452-0732  
Canada & US: 800-882-1587

Contact our Distributor Maser Technology Group:  
New Zealand tel 64-9-479-7889  
Australia 61-2-9970-7644



# The CABLE Connection

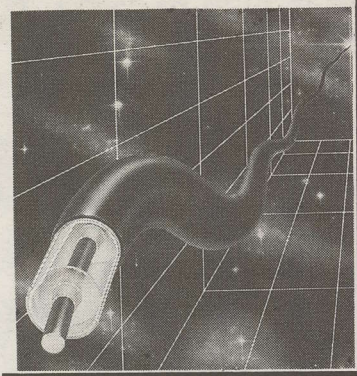

## Tiering (One)

Most community cable or satellite master antenna (SMATV) systems are designed around creating the maximum bandwidth possible to allow system distribution of as many television programme channels as possible; initially or in the future. A system that is designed to transport TV programme channels within the bandwidth of 48 to 300 MHz, for example, is theoretically capable of delivering 36 TV channels (spaced at 7 MHz intervals). Past issues of SF have dealt with how TV receivers connected to such a system are able to tune-in TV channels outside of the normal band I and III TV assignments.

The bandwidth of the system is initially determined by the system planner; numbers such as 48-300, 48-450, 48-550 (MHz) and so on are typical options offered. Once the bandwidth has been chosen, equipment designed to operate within that bandwidth is sourced and engineered to implement the system.

Nominally, most cable distribution systems design channelling around the tuning capability of (cable ready) TV receivers and set-top cable converter boxes. The most common standard with TV tuners is to space TV channels at 7 MHz intervals beginning at 48.25 MHz upwards to 294.25 MHz; a total of 36 evenly spaced channels. This is the so-called PAL-B format. At 300 MHz the channel spacing changes from 7 MHz to 8 MHz with 303.25 the next channel, followed by 311.25, 319.25 and onward to 439.25 (a 450 MHz system) or 543.25 (a 550 MHz system); the PAL-G system. TV receivers and set-top converters are varactor diode tuning 'programmed' to accommodate this step from 7 to 8 MHz spacing.

Bandwidth	# 7 MHz spaced TV channels	# 8 MHz spaced TV channels
48-230 MHz	26	0
48-300 MHz	36	0
48-450 MHz	36 (48-300)	18 (300-450)
48-550 MHz	36 (48-300)	31 (300-550)

There are, however, sound marketing reasons not to deliver the entire spectrum bandwidth to every TV receiver connected to the line. Suppose for discussion you were able to offer cable customers one, two or more channels as optional extras. A premium movie channel, an adult oriented channel, a quality children's channel such as Disney might be kept back as "extras" to be sold to those homes willing to pay more for the premium channels.

As more premium channels have become available to the cable operator, the cost of acquiring programming mounts. At some point the cable operator must either decline the new services, raise his cable rates to cover the additional costs of the new channels, or, offer certain channels as "extras."

Offering "extra" channels presents an engineering challenge. The entire plant was created to pass a carefully designed bandwidth and in theory any suitable receiver or set-top cable converter connected to the cable line can access any service within the bandwidth. So how do you selectively allow certain channels into some TV sets but not others when they are all plugged into the same broad bandwidth system?

A number of techniques have evolved, each has its merits and its foibles. A state of the art system will encode every TV channel on the system (i.e., scramble as in B-MAC type analogue scrambling seen on satellite) and equip every home with a computer controlled addressable set-top converter. Individual TV sets (homes) have only the channels they have agreed to pay for unscrambled by the set-top unit. A cable system computer sends instructions through the cable line to each set-top unit giving it instructions as to which channels can and cannot be descrambled. This seems like a wonderful solution but addressable set-top units run upwards of A/NZ\$300 each and the master computer that addresses the individual set-top units can easily be A/NZ\$25,000. Obviously this is not a cost effective approach for systems with fewer than perhaps 5,000 subscribers.

Another approach is to scramble only specific channels and provide (low cost) descramblers to those homes that subscribe to one or more of these premium channels. A single channel can be scrambled at the headend for approximately A/NZ\$1,500 and there are totally passive (use no power) "decoding filters" that cost the cable operator as little as A/NZ\$15 each. This is termed positive encoding because the premium channel is deliberately interfered with (scrambled) to prevent unauthorised viewing.

Yet another approach is to leave all channels (regular and premium) unscrambled on the system and install "negative traps" at the directional tap (cable line feeder point into the home). A negative trap eliminates one or more channels from the cable spectrum going into the house. Homes not taking the premium channel(s) are equipped with a negative trap while those taking the



Tap output with filter; "Basic"

Tap without filter; Basic + Premium

Full bandwidth cable passes through tap

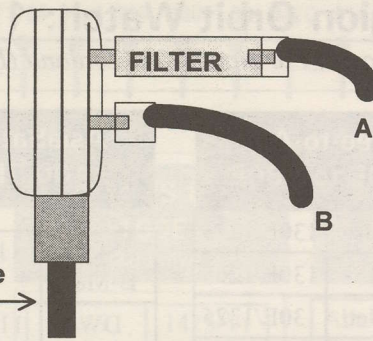

service are left alone to receive the full cable bandwidth. Negative traps eliminate the need for a headend scrambler but this may turn out to be a more expensive approach if the majority of cable homes elect to not take the extra premium channel(s) since each will require a negative trap at a cost in the range of A/NZ\$15 each. Additionally, the negative traps must be "secured" since a subscriber can gain access to the premium channels simply by removing the negative trap from their drop line.

**More Variations.**

One popular variation is to divide the cable bandwidth into segments, treating different portions as "tiers" or "levels" of service. For example:

- 1) **Basic Cable** - all channels between 48 and 196 MHz (capable of offering up to 21 channels)
- 2) **Basic Plus** - all channels between 48 and 294 MHz (up to 35 channels)
- 3) **Basic Plus Premium** - all channels between 48 MHz and the top of the cable bandwidth (450 or 550).

This is done by installing relatively low cost (A/NZ\$13) low pass filters on the directional taps for those customers who elect not to take the full service; see drawing above. The low pass filter allows all signals between 48 and some specified cut-off frequency to pass (such as 48-196; see bandpass plot below) but stops channels above that point. These filters require a "guard band," typically 14 MHz or two TV channels, to properly rolloff. In the plot shown here, the cable company would lose use of (channels) 196.25 and 203.25 to the guard band. Actually, they need not be totally lost as we shall see in SF#24.

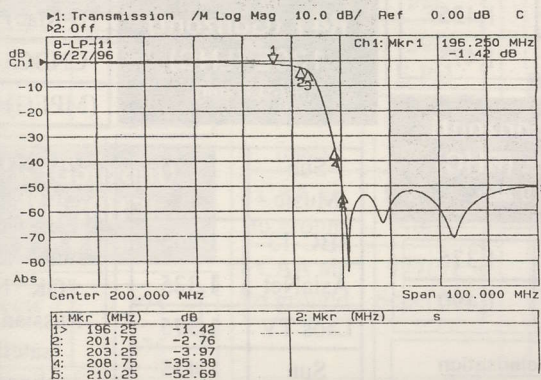

Eagle model 8-LP-11 Low Pass filter plot shows rolloff between 196.25 and 210.25 MHz (50+ dB)

P  
A  
C  
I  
F  
I  
C

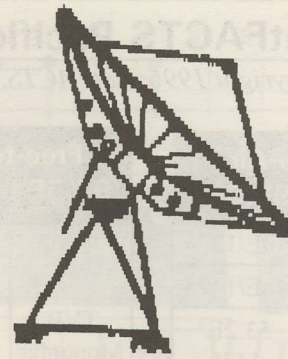

A  
N  
T  
E  
N  
N  
A  
S

Limited

*New Zealand's only stockist of preused transmit capable antennas - our stock presently consists of the following equipment:*

- 1 only 2° compliant 13 metre standard 'B' Vertex antenna with 4 port circular feed and Cassegrain sub-reflector
- 1 only 3° compliant 10 metre Scientific-Atlanta antenna with 2 port linear feed and Cassegrain sub-reflector
- 1 only 4.6 metre Andrew Ku Band antenna with 2 port feed and Gregorian sub-reflector
- 3 only 5 metre Sat Com Technologies transmit rated Ku band antennas
- 1 only 3.7 metre Comtech transmit antenna with Seavey transmit feed horn

**A selection of receive and transmit electronics including tracking equipment and motor drives with 15 to 50 ton azimuth and elevation jack screws.**

Pacific Antennas Limited is the major stockholder in New Zealand Teleport Holdings Limited, a teleport 90% construction completed. This facility has a standard 'B' 13 metre Vertex antenna with auto tracking capabilities. These companies can individually or collectively joint venture, lease, sell, operate or install all of the above equipment. We have the necessary licensing in place and the hardware has been installed for New Zealand's first privately owned independent standard 'B' uplink teleport. To learn more about business opportunities available, contact **Bryon G.G. Evans.**

**Pacific Antennas Limited**

PO Box 265 • Whangaparaoa (Auckland), NZ  
Tel/fax 64-9-424-0841 / Mobile 025-789-160



# SatFACTS Pacific Ocean Region Orbit Watch: 15 July 1996

Copyright 1996: SatFACTS, PO Box 330, Mangonui, Far North New Zealand (Fax: 64-9-406-1083)

Free-to-Air 40E to 96.5E	
RTPi	40E/1226
Rtr/Mart	40E/1475
ORTI	53.2E/ 1475
Ethiopia	57E/1220
Zee News	60E/961
ABN	62.9E/964
TV India	62.9E/986
WorldNet	66E/1135
Discovery	66E/984
Various	66E/1058
E TV	66E/1058
Discovery India	68.8/Pas4 Vt/1360
Sony Ent.	68.8/Pas4 Vt/1239
Movie Club	68.8/Pas4 Hz/1117
CNN	68.8/Pas4 Vt/1061
TNT+	68.8/Pas4 Vt/1036
BBC World	68.8/Pas4 Vt/995
MTV & Jain TV	68.8/Pas4 Vt/966
shaded indicates	reported in Europe
TW6 Mos.	80E/1275
TV Viet.	80E/1275
MAPTV	80E/1475
TK Rossi	80E/1475
TVi India	85E/1271
Moscow 1	90E/1475
Moscow 2	90E/1275
India 1	93.5/1025
India 2	93.5/1060
India 3	93.5/1420
Azerbaij.	96.5/1275
CCTV	96.5/1325
Moscow 1	96.5/1475

Free-to-Air 96.5E to 128E	
RTPi	100.5/Vt 1167
TVB Mongolia	100.5Hz 1470
CCTV Henan TV	100.5/Hz 1430
CCTV Guandong	100.5/Hz 1310
CCTV-4 Beijing	100.5/Hz 1183
Moscow 1	103.5/ 1472
Star TV	113/Vt 970
CFI	113/Hz 990
MTV Asia	113/Hz 1030
TPI	113/Hz 1070
TV Indosair	113/Vt 1090
ABN	113/Hz 1120
ANteve	113/Vt 1130
CNNI	113/Vt 1170
SCTV	113/Hz 1190
GMA	113/Hz 1230
TV3	113/Vt 1250
ATVI	113/Hz 1270
TVRI	113/Hz 1310
RTM	113/Vt 1330
RCTI	113/Hz 1350
CNBC	113/Hz 1530
JCSAT (test)	128/Vt 1166 & 12290Hz

Free-to-Air 130E to 180E	
Sun Music	130E/1225
IBC-13	130E/1265
AsiaNet	130E/1325
Laos TV	130E/1375
Sun Movie	130E/1425
RAJ-TV	130E/1475
Saudi TV	140E/1425
Moscow 1	140E/1475
Udaya	142E/1225
EMTV	142E/1265
EagleNet	142E/1325
RPN-9/ Globl 21+	142E/1375
JJAY	142E/1425
ASN	142E/1475
Moscow 1	145E/1475
Value Ch.	169E/Vt 970
NHK	169E/Hz 1115
CNN	169E/Hz 1183
CCTV-4 (MPEG)	169E/Hz 1426
RFO	180E/1105
WorldNet	180E/1179

**S14 (Gorizont)  
96.5E (RHC)  
+/- 3.2 deg.**

Jain TV	1,275
Muslim TV	1,425
Orbita II	1,475

**S21 (Gorizont)  
103.2E (RHC)  
+/- 1.9 deg.**

APNA	1,375
Orbita II	1,490

**Russian Polarisation**  
S (Stationar) series satellites  
are RHC (right hand circular);  
R series are LHC (left hand  
circular).

AsiaSat 2 100.7E	
Sky B-Mac	1130Vt
DW Bouquet (DVB MPEG)	1150Hz 1/DW 2/TV5 3/RTVE 4/MCM 5/RAI
RTPi	1167Vt
CCTV-4	1183Hz
Reuters	1230Hz
STAR Japan (DVB MPEG)	1250Vt 1/"Plus" 2/BBC 3/VIVA 4/CNBC 5/NBC Asia 6/Sky
CCTV-2	1310Hz
APTV	1351Hz
News- crypt	1390Hz
STAR Asia (MPEG/ CA)	1410Vt 1/"Plus" 2/BBC 3/VIVA
CCTV-1	1430Hz
STAR Asia (MPEG/ CA)	1450Vt A/D'Star B/D'Star C/D'Star
TVB Mongolia	1470Hz

**R41 (Gorizont)  
130E (LHC)  
+/- 0.8 deg.**

Sun Music	1,225
IBC-13	1,265
AsiaNet	1,325
Laos TV	1,375
Sun Movie	1,425
RAJ-TV	1,475

Palapa C2M 113E	
Star TV	970Vt
CFI	990Hz
Radio TV Brunei	1010Vt
MTV Asia	1030Hz
ESPN (B-Mac)	1050Vt
TPI	1070Hz
TV Indosair	1090Vt
	1100Hz
ABN	1120Hz
ANteve	1130Vt
HBO (B-Mac)	1150Hz
CNNI	1170Vt
SCTV	1190Hz
	1210Vt
GMA	1230Hz
TV3	1250Vt
ATVI	1270Hz
	1290Vt
TVRI	1310Hz
RTM	1330Vt
RCTI	1350Hz
(data)	1370V
TNT+ (B-Mac)	1390Hz
(data)	1410Vt
Discovery (B-Mac)	1430Hz
CNBC (MPEG)	1530Hz
	1700Hz

**NOTES:**  
C2M replaced C1 at  
113E over period 28  
June - 1 July. **Bold**  
"OK" NZ on 3m.  
Russian R,S series  
satellites are  
inclined orbit; +/-  
indicates extent of  
present inclination.



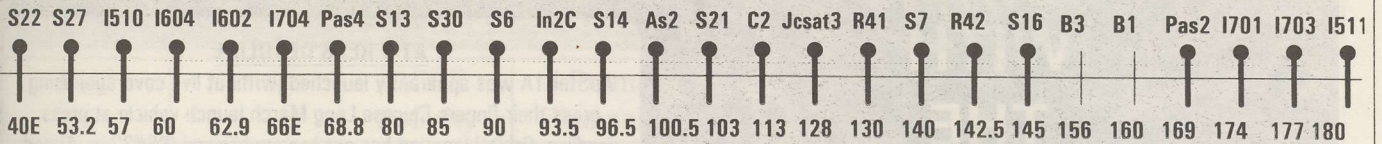

**OPTUS B3**  
**156E**  
(Ku only)

(B-Mac)	1425/Vt
Central ABC HACBSS	1393/Hz B-Mac
Vic. ETV	1361/Vt CryptV.
Imparja TV	1329/Hz B-Mac
(B-Mac)	1297/Vt
Net 9, Sky specials	1233/Vt B-Mac
Central ABC HACBSS	1201/Hz B-Mac
	1169/Vt
Galaxy	1137/Hz Irdeto Mpeg 2
	1105/Vt
Galaxy	1073/Hz Irdeto Mpeg 2
Golden West	1041/Vt
	1009/Hz
	977/Vt

**S7 (Gorizont)**  
**140E (RHC)**  
+/- 4.3 deg.

Saudi TV	1,425
Orbita I	1,475

**S16 (Gorizont)**  
**145E (RHC)**  
+/-3.8 deg.,

Moscow 2	1,275
Moscow 1	1,475

Optus Ku Listing Credit to Garry Cratt of AV-COMM Pty Ltd.

**OPTUS B1**  
**160E**  
(Ku only)

Net 9, Sky feeds	1425/Vt B-Mac
Data	1402/Hz
QTV	1377/Hz B-Mac
NE ABC HACBSS	1370/Vt B-Mac
NE SBS HACBSS	1344/Vt B-Mac
SE SBS HACBSS	1339/Hz B-Mac
SE ABC HACBSS	1313/Hz B-Mac
Sky Channel	1296/Vt B-Mac
ABC Radio	1276/Hz (digital)
OmniCast	1270/Vt (FM/FM)
ABC feeds	1247/Hz Pal
Net 7	1244/Vt E-Pal
Net 9 feeds	1219/Vt Pal&Ntsc
	1214/Hz
Net 10	1182/Vt E-Pal
Net 9	1180/Hz E-Pal
Net 10 feeds	1155/Vt Pal
Net 7	1120/Vt E-Pal
Net 9 feeds	1091/Vt Pal
CAA air to ground	1009/Vt Nbfm
CAA air to ground	977/Vt Scpc(fm)

**PAS-2**  
**169E**  
(C + Ku)

Abn/Ctn/Cctv/Nbc	1,426/Hz (Sa9222)
Cmt/Cbs/(to30-07)	1408/Vt (Sa9222)
Discovery (1/2Tr)	1374/Hz B-Mac
MTV Asia	1346/Vt B-Mac
ESPN	1288/Vt B-Mac
MPEG-2 PowerVu Sylmar	1249/Hz (Sa9223)
TNT+ (1/2Tr)	1218/Vt B-Mac
CNN+ (1/2Tr)	1183/Hz
FoxSports	1161/Vt (Sa9222)
NHK	1115/Hz
Filipino Channel	1060/Hz (GI Mpeg)
NBC Mux MPEG	1057Vt (Pace)
MPEG-2 PowerVu HonKong	1002Vt (Sa9223)
Value Ch.	970Vt

**PAS-2 Ku**

Pas2 test	12,337
Test card	12,413
Karaoke	12,730/H

**R42 (Gorizont)**  
**142.5E (LHC)**  
+/- 0.8 deg.

Udaya	1,225
EMTV	1,265
EagleNet	1,325
RPN9,21	1,375
JJAY	1,425
ATN	1,465

**Intelsat 701**  
**174E**

Feeds	963
Feeds	984

**Intelsat 703**  
**177E**

AFRTS	973 B-Mac *
Feeds	980

\* uniquely left hand circular

**Intelsat 513**  
**177W**

Feeds	963
Feeds	984

**(513 Ku)**

Service	RF Freq.
US Nets	10980Vt
NBC	11015Vt
Feeds	10510Vt

**Ku Services**  
Intelsat Ku band services shown here are boresighted to Japan and nearby Asia, have not been reported south of equator. At boresight, signals of <2m levels.

**Intelsat 511**  
**180E(W)**  
+/- 2.4 deg.

TVNZ	964/Ntl 3000
TVNZ	972/Ntl 3000
TVNZ	980/Ntl 3000
TVNZ	988/Ntl 3000
Aust 9 (data)	1,021 * 1,054
Canal + (data)	1,054 ** 1,092
RFO Tahiti	1,105
(vacant)	1,137
World-net	1,179
CBS/e	1,223
Keystone	1,256
NBC/e	1,277
Mpeg tests	1,310
Mpeg tests	1,325
Mpeg	1,388
Keystone	1,432

\* RHC & LHC  
\*\* LHC only e/ encryption

**(511 Ku)**

Service	RF Freq.
CBS	11480Hz
CNNI	11510Hz

**UPCOMING SATELLITE LAUNCHES**

'Anytime Now' / 2nd Russian Express to 95E(?).  
October/ 1801 to 174E (with 701 at 174 moving to 180E late in 1996).  
December/ MPSC (Philippines) to 144E.  
January('97)/ 11803 to 177E.



# WITH THE OBSERVERS

## AT PRESS DEADLINE

ApStar 1A was apparently launched (without live coverage) using cross-their-fingers Chinese Long March launch vehicle at press deadline. Orbital location has not been publicised (SF#22, p. 4) and may in fact not be dead certain even as launched. One option - 122E. Satellite footprints are expected to be like ApStar 1 (138E).

## C2M Alight

SatFACTS last reported in issue #22 (p. 1, 28) test transmissions originating at 124E from C2M. These carriers were widely reported throughout Asia and the Pacific. By the middle of June even the telemetry beacon signal (observable on a spectrum analyser) had disappeared from 124E, indicating the satellite had gone silent or was being moved.

As embarrassing as the C1 situation has been to the Indonesians and satellite builder Hughes, it is understandable why no advance "notice" was given that C2M was being moved to 113E and further that all C1 video and data traffic would be transferred from C1 to C2M. They apparently wished the transfer to be as "transparent" as possible.

The actual turn off of C1 transponders and the companion turn-on of C2M transponders from essentially the same location began on June 28 and was completed by 1 July. SF began receiving "abnormal signal level" reports the morning of the 28th; a number of NSW (Australia) observers (**David Leach**, et al) saw their CDE-2000 B-MAC decoders, which previously worked only on HBO and TNT routinely and Discovery on occasion, suddenly burst to P5 quality pictures on Discovery and P4 images on ESPN. The CDE-2000 channels (vertical 4100 /IF1050, horizontal 4000/IF1150, 3760/IF1390, and 3720/IF1430) have a "hair trigger" threshold between full noise free lock and dropping out so a small positive change in signal level can produce dramatic results. **Steffen Holzt** (New Caledonia) finds CFI, TPI, HBO, GMA, TVRI and TNT up by as much as 2dB while MTV, ABN, SCTV, ATVI, RCTI and Discovery are down by similar amounts. See SF#20, p. 10 for a table that lays all of this out.

Other early reports suggest there have been no major changes in signal levels at any point; C2M signals in Asia are typically 0.5 to 1dB stronger than C1 while in New Zealand the vertical side transponders appear to have diminished by as much as 1dB while the strong 6 on horizontal came up by a similar amount. We direct you to the C1 v. C2M comparison reporting form on page 30 of this issue and urge readers to complete it for a final analysis.

Of interest: Observer **Chris Bradley** located on an oil rig platform located off the northern Australia coast towards Indonesia observed approximately 2 hours of simultaneous C1 and C2M testing on the 18th of June with C2M located at approximately 115E for the test period. Chris reports, "It was

## NEW on Rimsat 142.5E



Rimsat's 142.5E hemispheric beam TR8 (1375IF) has been "for lease" for nearly one year (previously used for narrowband communications). During June the promotion slide for "Plus 21" interspersed with a segment of a Hindi female brutality movie ran for weeks, replaced late in June with the promotion for a cable TV company headend equipment package (below). On July 5th, routine programming began under network banner "RPN-9" with heavy USA off-network programming content (Simpsons, et al).

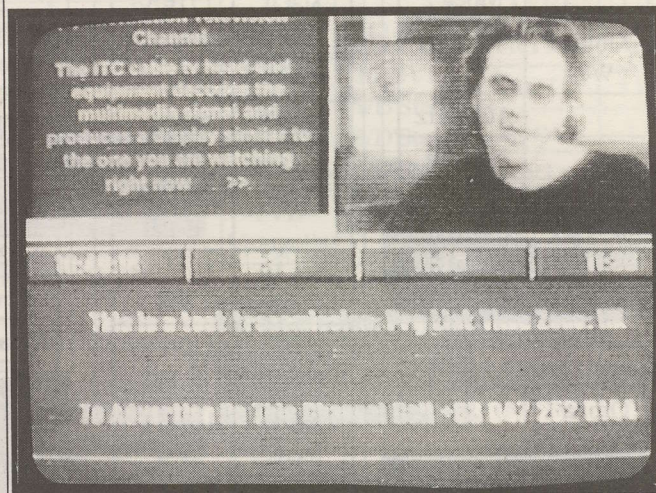

**WITH THE OBSERVERS:** Reports of new programmers, changes in established programming sources are encouraged from readers throughout the Pacific and Asian regions. Information shared here is an important tool in our ever expanding satellite TV universe. Photos of yourself, your equipment or off-air photos taken from your TV screen are welcomed. TV screen photos: If PAL or SECAM, set camera to f3.5-f5 at 1/15th second with ASA 100 film; for NTSC, change shutter speed to 1/30th. Use no flash, set camera on tripod or hold steady. Alternately submit any VHS speed, format reception directly to SatFACTS and we will photograph for you. Deadline for August 15th issue: August 3 by mail (use form appearing page 30), or

5PM NZT August 5th if by fax to 64-9-406-1083.



## MPEG-2 TUNING PARAMETERS

Bird	Service	RF/IF Polarity	# Prgme Channels	FEC	(K)(M)s/s	Interoperable Receivers
As2	EBB	4000/1150 Hz	5TV, 9 radio (a)	3/4	28.125	NTL, DGT400, DVR500, IRD520
	Star +	3900/1250 Vt	7TV, 1 radio (b)	1/2	28.100	NTL
	APTV	3799/1351 Hz	1TV, 1 aux.	3/4	5.632	NTL, ComStream
PAS2	TCS Singapore	4183/967Hz	2TV	1/2	6.62	S-A PowerVu
	S-A HK MCPC	4148/1002 Vt	6TV (c)	2/3	24.43	S-A PowerVu
	NBC HK	4093/1057 Hz	7TV (d)	3/4	29.473	NTL, DGT400, DVR500, IRD520
	S-A Cal MCPC	3901/1249 Hz	6TV (e) (to be 8)	3/4	30.800	S-A PowerVu

a) (1) Deutsche Welle TV, (2) TV5, (3) RTVE, (4) MCM, (5) RAI Uno, (6) DW Radio (1), (7) DW Radio (2), (8) DW Radio (3), (9) YLE Radio, (10) Swiss Radio, (11) Radio Canada, (12) World Radio, (13) Radio Express, (14) Radio France. b) (1) Star Plus Japan (English) /NTSC, (2) BBC World, (3) VIVA Cinema, (4) CNBC, (5) NBC Asia, (6) Sky News London, (7) Star Radio, (8) Star Plus Japan (Japanese)/NTSC. c) [Note: As of July 5 this feed was temporarily turned off] (1) CTN News, (2) CTN Entertainment, (3) TVBS and other feeds NTSC, (4) CCTV-4 NTSC, (5) NBC Asia, (6) ABN. d) (1) CNBC, (2) CNBC Mandarin A, (3) Test, (4) NBC Asia, (5) CNBC Mandarin B, (6) NBC Asia Mandarin, (7) Test. e) (1) CMT NTSC, (2) CBS feeds, others NTSC, (3) ABC feeds, others NTSC, (4) ESPN2 NTSC, (5) BBC World NTSC, (6) Bloomberg Financial Service NTSC

**TRIAL  
SAMPLE  
QUANTITIES**

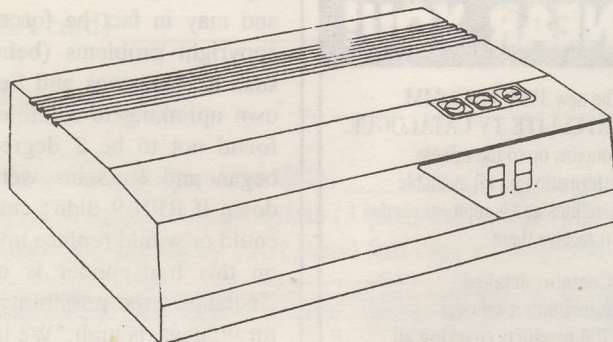

**IN  
STOCK  
FOR  
IMMEDIATE  
SHIPMENT!**

## 47 - 550 MHz CABLE (SMATV) SET-TOP CONVERTERS

OPEN UP the full 500 MHz spectrum to standard TV receivers: Tune any channel from 47 to 300 MHz (in 7 MHz steps) or any channel from 300 to 550 in 8 MHz steps! PERFECT for motels, hotels requiring additional spectrum tuning capability in lieu of replacing all existing TV receivers.

✓ **IR remote control** - 10m distance ✓ **Favourite Channel Memory** - tune and LOCK only those channels you wish each receiver to access ✓ **PASSWORD** protection on channels locked in memory to avoid user reprogramming ✓ **SAVES** Favourite Channel positions in memory even when power is cut or unit switched off ✓ **LAST CHANNEL** recall to swap between any two channels ✓ **CABLE** system design and proven ("F" connectors in and out). **PRICING:** Under A/NZ\$100 in quantity.

**Far North Cable TV Ltd.**  
*The Cable TV Supply Place*

PO Box 30, Mangonui, Northland,  
NZ · Tel 64-9-406-1282 Fax  
64-9-406-1083

SatFACTS July 1996 • page 27



## JULY-AUGUST SPECIALS

### KTI DISHES ECHOSTAR RECEIVERS CHAPARRAL FEEDHORNS

WHAT Satellite TV Magazine rates  
ECHOSTAR receivers tops in performance!

TOP quality product, UNBEATABLE pricing!

**ECHOSTAR** receivers from \$395  
**ECHOSTAR** receiver/positioners from \$750

**KTI** CKD 3m polar \$895

**KTI** CKD 3.7m polar \$1450  
Venture or HTS 24" jack \$230  
20K C-band LNB \$135

Quatro 10.7-12.7 Ku-band \$198  
**Chaparral** Feeds from \$95

all prices plus gst and freight  
VISA & Bankcard OK!

### BARNETTS RADIO & TV SERVICE

42 Anderson Road • Wanaka (NZ)  
Ph/Fax (64)-3-443-7961  
After hours Ph/Fax (64)-3-443-7476

## NOT COMING TO A NEWSAGENT NEAR YOU!



The new 1996 AV-COMM SATELLITE TV CATALOGUE, contains up to the minute information on all available satellites and equipment needed to receive them.

Contains detailed information on over 200 products covering all aspects of Satellite Television Reception.

For your FREE copy of the new 1996 AV-COMM CATALOGUE simply complete the coupon and send to: AV-COMM PTY. LTD. P.O. Box 225, Balgowlah NSW 2093.

YES Garry, please send me a FREE copy of the 1996 AV-COMM Satellite TV Catalogue.

Name: \_\_\_\_\_

Address: \_\_\_\_\_

P'code: \_\_\_\_\_

Phone: ( ) \_\_\_\_\_

### AV-COMM PTY LTD

A.C.N. 002 174 478

198 Condamine Street,  
Balgowlah NSW 2093  
Tel: (02) 9949 7417/9948 2667  
Fax: (02) 9949 7095

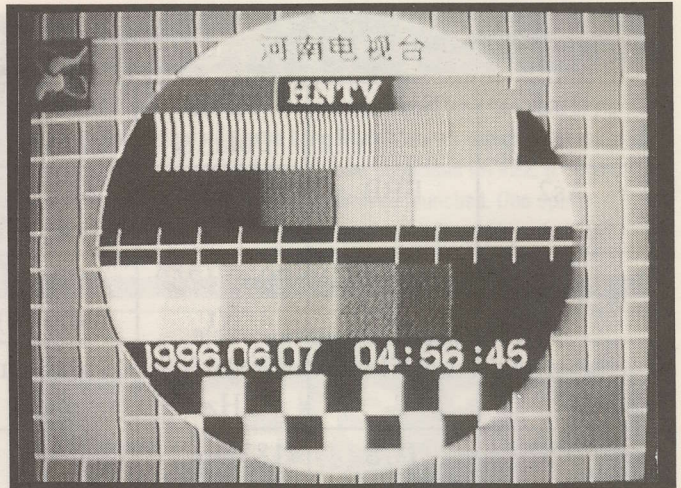

Henan TV (Hz, IF1430) is one of three new "Asian" TV services now on AsiaSat. HNTV and Guangdong Satellite TV (Hz, IF1310) are not all Mandarin (Wimbledon Tennis was carried, for example). Third new service is Mongolian TV (MTB) on horizontal, (IF1470) which is in Russian SECAM.

*magic to switch back and forth between the two satellites."* Eric Fien (NSW) reports ABN (1130), ATVI (1270), MTV (1030; all Hz) improved; others same or worse on C2M. The saga of C1 will not be complete until some final decision is made about where this satellite will ultimately end up and how it will be utilised. For now, it is a wait and see game.

**Rimsat 142.5E, TR8:** Global TV had not completed contract finalities as of 5 July so has not begun "21 Plus" service here; promotion with cigarette burning of female actress continues within their 4 hour time slot (1630-2030UTC). Filipino English language station RPN-9, seen here July 5, has only 90 day contract to use this transponder (2200-1600UTC daily) and may in fact be forced to analogue scramble because of copyright problems (being heavily into USA programming such as Simpsons and Seinfeld). Station launched by doing own uplinking to satellite July 5th, their uplink antenna was found not to be 2 degree certified several hours after they began and Russians were threatening to close transponder down if RPN-9 didn't correct their uplink antenna. That they could or would replace non-compliant antenna for a 90 day run on this transponder is questionable. Given this myriad of challenges, the possibility that RPN-9 may not be here, even for 90 days, is high. We live in strange times ...

**Business Notes:** AsiaSat went into the public stock market (Hong Kong and New York) June 19 and was promptly over subscribed, closing up 25% higher than the initial offering price. More than 121 million shares were sold raising US\$313 million for construction of As3 (late 1997) and As4 (1999). The International Organisation of Space Communications, known as Intersputnik V-III, has been formed to construct and operate a fleet of new satellites. Unlike previous Intersputnik ventures, this one will source satellites from a consortium of non-Russian manufacturers. The first two satellites to be launched 1998/1999 are scheduled for 75E and 16W and will have on board C-band regional, hemispheric and global beams as well as spot Ku beams. Australia is part of the coverage region from 75E. The firm has filed for 15 orbital locations through the country of Belarus (formerly a part of Russia). Marketing co-ordinator is Tim Brewer, formerly Rimsat and AsiaSat.



**EVERY MONTH - MAJOR NEW CHANGES!**  
**SUBSCRIBE TO SatFACTS USING THIS FORM**

1996 - THE year of home satellite TV (DTH) is now one-half over. How has it performed? Check the Orbit Watch listing on pages 24-25: One year ago Orbit Watch listed 40 possible TV channels. Today there are more than 160 separate programme channels listed and the list is growing monthly!

- ENTER my 12 MONTH subscription to SatFACTS starting with AUGUST 15th issue (rates below)  
 ENTER my 36 MONTH subscription to SatFACTS starting with AUGUST 15th issue (rates below)

NAME \_\_\_\_\_

Company (if applicable) \_\_\_\_\_

Mailing Address \_\_\_\_\_

Town/City \_\_\_\_\_ Country \_\_\_\_\_

**Amount to send:** 1 year - NZ\$40/A\$75/(\$US40 outside NZ and Australia) or 3 years - NZ\$100/A\$175/ US\$100 if by cheque. **VISA?** See form below and return with order. Return to: SatFACTS, PO Box 330, Mangonui, Far North (NZ) or if by VISA by FAX to 64-9-406-1083.

**USE THIS FORM ONLY WHEN CHARGING ON VISA CARD**  
(and PLEASE ALSO COMPLETE TOP PORTION AS WELL!)

**Please charge my VISA card as follows:**

- One Year of SatFACTS MONTHLY (NZ\$40/A\$75/US\$40)  
 Three years of SatFACTS MONTHLY (NZ\$100/A\$175/US\$100)  
 SATELLITE TELEVISION: The Booklet (NZ\$10/A\$12/US\$10)  
 One year of COOP'S TECHNOLOGY DIGEST (NZ\$125/A\$125/US\$125)  
 The WORLD of SATELLITE TV-1992 edition (NZ\$15/A\$20/US\$20)

Name (as it appears on VISA card) \_\_\_\_\_

Visa Card Number: \_\_\_\_\_ - \_\_\_\_\_ - \_\_\_\_\_ - \_\_\_\_\_

Visa Card Expiration date: \_\_\_\_\_

**Instructions:** If ordering by mail, return this complete (3-part) card (SatFACTS, PO Box 330, Mangonui, Far North, New Zealand); if ordering by FAX, send full card as single sheet to 64-9-406-1083.

**SUPPLEMENTAL MATERIALS from SatFACTS MONTHLY: Order Form**

- SATELLITE TELEVISION:** The Booklet. Excellent introduction to home dish ownership for the layman with contributions from world famous science writer *Arthur C. Clarke*. The perfect tool to help the system seller explain dish ownership to prospective customers, from *SPACE Pacific*. NZ\$10/ A\$12/ US\$10 by fast post.
- COOP'S TECHNOLOGY DIGEST.** For the really serious enthusiast, investor, business person in satellite TV and allied industries. Ten issues per year, jam-packed with information you will not find anywhere else. "Coop" routinely culls more than 60 monthly publications, \$1,500 per year newsletters, Internet and his hundreds of private contacts to keep you up to date on the REAL changes underway in telecommunications. Conveniently issued near **first** of the month, provides excellent time-line-filler between mid-month issues of SatFACTS. Now in 4th year, airmail world-wide. Normally NZ/A/US \$250 per year; for limited time 50% off offer at NZ/A/US\$125.
- WORLD OF SATELLITE TV - 1992 edition.** The famous *Mark Long* handbook that takes a novice and turns him or her into a satellite TV pro! 1996 edition \$45 or more; this special offer only NZ\$15/A\$20/US\$20.



## OBSERVER REPORTING FORM - Due AUGUST 5, 1996

- **New programming** sources seen since July 1st: \_\_\_\_\_
- **Changes** (signal level, transponder, programming content) in pre-existing programming sources since July 1st: \_\_\_\_\_
- **Other** (including changes in your receiving system): \_\_\_\_\_

**Note:** Please use P1-5 code when describing reception quality and receiver IF or RF settings.

Your name \_\_\_\_\_  
Town/City \_\_\_\_\_  
Make/Size dish \_\_\_\_\_ LNB \_\_\_\_\_ Receiver \_\_\_\_\_

**Mail:** SatFACTS, PO Box 330, Mangonui, Far North, New Zealand. **Fax:** 64-9-406-1083

## SPECIAL C2M v. C1 COMPARISON REPORT

C2M between 28 June and 1 July replaced C1 at 113E, we ask you to COMPARE the C2M programme feeds with the same feeds (as appropriate) from C1 at 113E. C2M will be either "better than," "same as" or "worse than" C1 on a transponder by transponder basis.

**C2M NOW AT  
113E**

Programme Channels **BETTER** on C2M: \_\_\_\_\_

Programme Channels **SAME** on C2M & C1: \_\_\_\_\_

Programme Channels **WORSE** on C2M: \_\_\_\_\_

Your notes: \_\_\_\_\_

Name \_\_\_\_\_ Telco (Fax) \_\_\_\_\_  
Address \_\_\_\_\_ Town \_\_\_\_\_

Mail to SatFACTS, PO Box 330, Mangonui, Far North, NZ or fax 64-9-406-1083

## WANT TO KNOW MORE ABOUT SPRCS '97 IN JANUARY?

Return this no obligation form

INFORMATION PACKS describing the 1997 South Pacific Region Satellite & Cable Show (January 21-25 in Auckland) will be distributed shortly. Make plans now to attend this excellent show and return this form to be assured of receiving the first detailed announcement.

YES - send me SPACE SPRCS '97 show packet!

I am  am NOT  a member of SPACE Pacific.

NAME \_\_\_\_\_

Address \_\_\_\_\_

Town/City \_\_\_\_\_

**Return to:** SPACE Pacific, PO Box 30, Mangonui, Far North, New Zealand



# ORBITRON

Complete Satellite Antenna Systems World Wide

*PRECISION  
PERFECTION  
DURABILITY  
DEPENDABILITY  
SERVICE  
SELECTION  
EXCEPTIONAL  
EXPERIENCE  
INNOVATIVE  
NUMBER ONE  
AMERICAN MADE*

**NEED WE SAY MORE.**

ORBITRON  
351 S. Peterson St.  
Spring Green, Wisconsin U.S.A.  
53588  
Tel (608) 588-2923  
Fax (608) 588-2257



IN NEW ZEALAND: Telsat Communications Ltd., PO Box 1537, Palmerston North  
Tel: 64-6-356-2749 • Fax: 64-6-355-2141



# UNIDEN SATELLITE TELEVISION

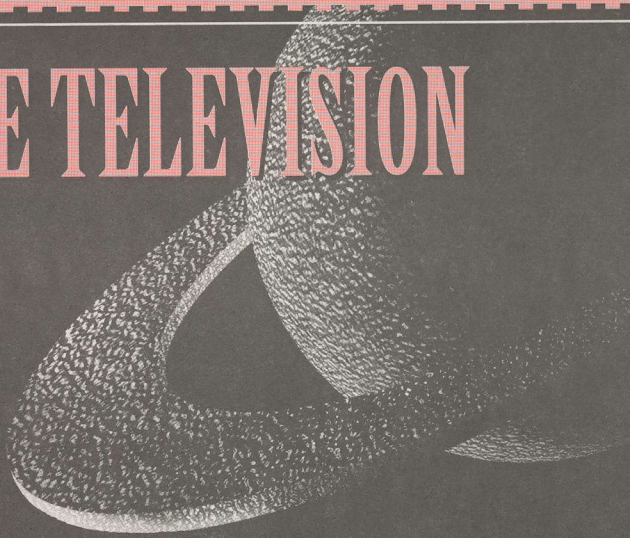

## *JUST IMAGINE...*

*Over thirty channels of free-to-air television from around the globe available throughout New Zealand. even in areas where present free-to-air or paid channels don't reach.*

*THIS IS NOT A DREAM, It's a reality. And it's available to your customers right now, with equipment costs that are probably a lot less than you would expect.*

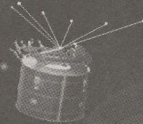

*Uniden are about to launch their Satellite Television Package to dealers throughout New Zealand.*

*If you would like to find out how to profit from satellite television in New Zealand give Uniden a call.*

*After all, Uniden is one of the world leaders in satellite television technology.*

## UNIDEN SATELLITE TELEVISION

*Putting You Face To Face With  
A World of Entertainment*

**uniden®**

*a Clear Signal of What's Ahead*

*For more information Phone 0-9-273 8383 or Fax 0-9-274 0009*

*Uniden® is a registered trademark of the Uniden Corporation of Japan Ltd and is represented in New Zealand by Uniden (NZ) Ltd.*