

Bob Cooper's

FEBRUARY 15 1996

SatFACTS

MONTHLY

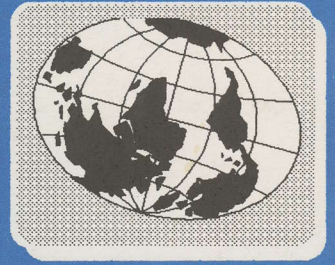

Reporting on "The World" of satellite television in the Pacific Ocean Region

IN THIS ISSUE

AsiaSat 2
on 1.8 - 2.4 metre
C-band dishes
during SPRSCS

**SIX EUROPEAN
CHANNELS**
Free to Air
From AS2!

STILL MORE:
Mark Long on *The Year
Ahead*, detailed
SPRSCS report,
current AS2 data

- ✓ Latest programmer news
- ✓ Latest hardware news
- ✓ Latest SPACE Pacific
Programming Access
- ✓ Cable TV
Connection

Vol. 2 ♦ No. 18
Price Per Copy:
NZ\$8/A\$9 ♦ US\$5



Paraclipse[®]

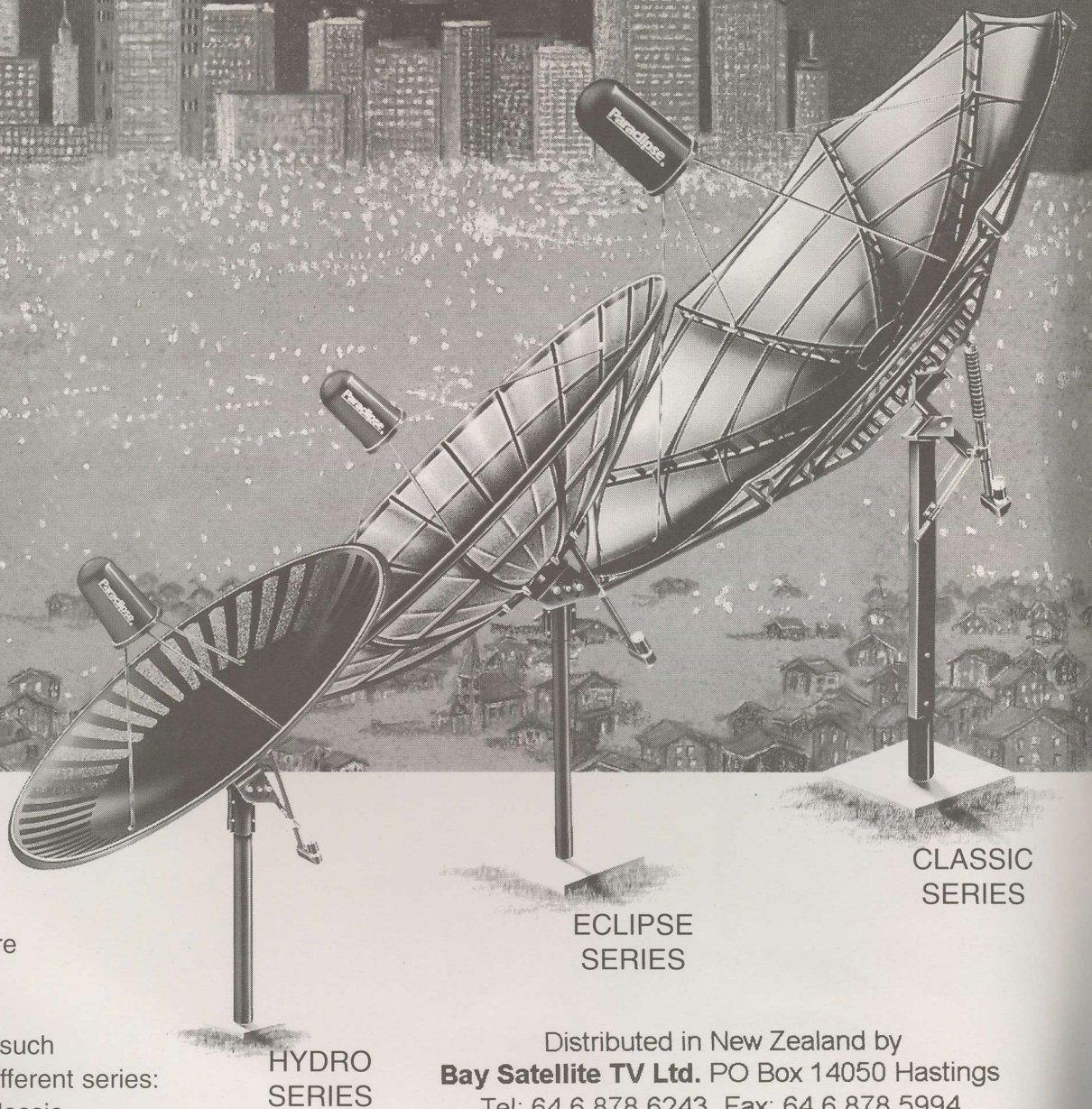

When quality, strength, and accuracy are your main requirements, **Paraclipse** antennas are your first choice.

Only **Paraclipse** offers such variety; four distinctly different series:

- the Truss-Ribbed Classic,
- the Courier Deliverable Eclipse,
- the Stretch Formed Hydro,
- the Commercial Patriot.

Every **Paraclipse** model sets the industry standard in its class, worldwide.

HYDRO
SERIES

ECLIPSE
SERIES

CLASSIC
SERIES

Distributed in New Zealand by
Bay Satellite TV Ltd. PO Box 14050 Hastings
Tel: 64 6 878 6243 Fax: 64 6 878 5994

Paraclipse[®]

HIGH PERFORMANCE ANTENNAS

Paraclipse Inc.
2271 29th Avenue East, Columbus, Nebraska USA 68601
Telephone: (402) 563-3625 FAX: (402) 564-2109

★ **MADE IN AMERICA**

SatFACTS

MONTHLY

SatFACTS Monthly is published 12 times each year (on or about 15th of each month) by Far North Cablevision, Ltd. This publication is dedicated to the premise that as we enter the 21st century, ancient 20th century notions concerning borders and boundaries no longer define a person's horizon. In the air, all around you, are microwave signals carrying messages of entertainment, information and education. These messages are available to anyone willing to install the appropriate receiving equipment and, where applicable, pay a monthly or annual fee to receive the content of the messages in the privacy of their own home. Welcome to the 21st century - a world without borders, a world without boundaries.

Editor/Publisher:

Robert B. Cooper
(ZL4AAA)

Office Manager:

Gay V. Cooper
(ZL1GG)

Reaching SatFACTS

Tel: 64-9-406-0651
Fax: 64-9-406-1083
Mail: PO Box 330
Mangonui, Far North
New Zealand

Subscription Rates

Within NZ: NZ\$40 p/y
Australia: AV-COMM Pty
Ltd, PO Box 225,
Balgowlah NSW 2093 /
61-2-9949-7417
Elsewhere: US\$40 p/y

ERRATA

SatFACTS copyright 1996
by Robert B. Cooper, any
form of copying is a
violation of our
international copyrights.
Advertising rate sheet
available upon request.

COOP'S COMMENT

Many of the presenters appearing at SPRSCS '96 received both a warm welcome and appreciative applause at the end of their talks. Johannes Firsbach of Germany's Deutsche Welle international service did better than this; his presentation was twice interrupted by spontaneous applause. And for good reason.

Deutsche Welle (DW) has leased a 36 MHz transponder on AsiaSat 2. Using DVB Compliant MPEG, it will soon begin transmitting five separate free to air television programme channels and as many as 20 audio and data 'channels' some of which



Deutsche Welle's Johannes Firsbach made many attendees very happy during SPRSCS.

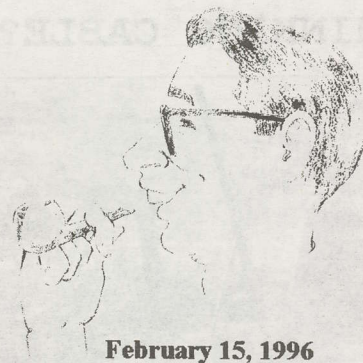

February 15, 1996

will interface directly with a user's home PC to unload massive amounts of news and information. Some have dubbed this package "The European Programming Bouquet" and included in the TV stream are Germany's DW, France's TV5, Italy's RAI and Spain's TVE. Identity of the 5th television programmer will wait formal contract signing. Included in the audio and data digital streams is a cross section of music and news programmers from classical to pop and full-time news in various languages. And it is all free to air.

As2 completes encirclement of the globe for DW; the present 2-1/2 hour segment WorldNet (Intelsat 180) contract expires

March 31 and if renewed will continue only until June. Of course the new As2 service is 24 hours per day, of which 10 hours is in English.

While attending SPRSCS Firsbach signed contracts with cable TV systems (my Far North Cable TV was the first to sign-up), UHF TV broadcasters in five New Zealand areas, and a service called Tourist Radio which will take the As2 feed and send it to more than 200 low power German language FM radio translators spread nation-wide in New Zealand.

DW is insisting that users (whether DTH, cable or broadcast TV and radio) have fee-free access to their services. They presently plan to commence DVB MPEG service in April (they would start today if there were receivers being shipped by Pace and others), could start (TR10B, Horizontal; IF 1150) in a "test analogue" shared format earlier.

Combine the five "European Bouquet" services with the already available Radio TV Portugal (TR9A, vertical; IF 1170) and we have six European telecasters broadcasting in the major European languages to the Pacific and Asia. And this is but the beginning of a world-wide trend to make available free to air a multiplicity of "national" TV services.

The ramifications of this enlightened policy, spear headed by Deutsche Welle, are many as we shall explore in depth next month in SF#19.

In Volume 2 ♦ Number 18

On The Threshold Of A Dream (Mark Long) -p.6

THE Show (SPRSCS Report) -p. 11

Departments

Programmer / Programming Update -p.2; Hardware / Equipment Update -p.4
SPACE Notes: SPRSCS Forum Synopsis -p.20 ; The Cable Connection -p.22

With The Observers -p.25

SatFACTS Orbit Watch -p.27; February Reporting Form -p.30

-ON THE COVER-

AsiaSat 2, look angle below 5 degrees, on a 1.8m dish. Norm Bruner, Paracclipse USA, tweaks the feed on his company's hydro-formed antenna on a test stand during SPRSCS in Auckland. South Pacific region installers are rewriting the book on low look angle reception techniques driven by the exceptionally attractive programming packages just above the western horizon.

-IN SF#19-

Selling The "European Bouquet"

THINKING CABLE?

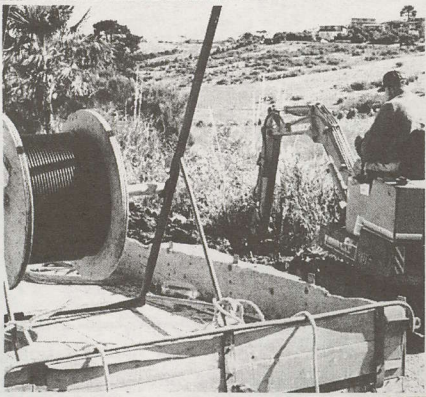

We have the expertise, supplier contacts, system design capabilities to assist you in your own system feasibility study.

- ✓ We will design your system and specify all hardware
- ✓ We will provide hardware sourcing and pricing based upon our bulk buying power
- ✓ We will assist you in selecting the "best" programming mix for your community
- ✓ We will assist you in negotiating favourable programme use rights
- ✓ We will prepare system cash flow and funding documentation to help you obtain financing

Our charges are negotiated for each system based upon mileage and headend complexity, and we offer an exchange of our services for an equity position in your system as a form of payment.

Serious system planners may visit our Doubtless Bay 34 channel system to learn what a modern cable TV system is all about.

*-CABLE TELEVISION-
Giving the consumer
new choices in viewing.*

Far North Cable TV Ltd.
tel 64-9-406-0651
fax 64-9-406-1083

PROGRAMMER PROGRAMMING PROMOTION

UPDATE

FEBRUARY 15, 1996

Palapa C1 launched successfully, was within 0.2 degrees of assigned orbit position (113E) February 5 with test signals expected as early as February 9.

EMTV has signed no Intelsat (801) contract, has no present plans to move (SF# 17, p. 28) satellites. GM Geoff Kong advises "We are looking at a wide range of options and will attend a (Rimsat) user group meeting in March to determine what other 130/142.5 satellite users are planning." Amongst options: AsiaSat 2, one of the newer Intelsats (174 or 180E), or stay with Rimsat 142.5. Their current contract runs until end of this year. "Nau-FM will be with us, regardless of where we are in a year and like everyone else we have to be planning for digital as well." EM TV sees itself as a Pacific regional service, actually regrets the present spillover coverage into Asia from 142.5E.

"We were forced to give up some cricket tests in the past month because our coverage intrudes into the ESPN coverage regions, and, they decided to take the tests." Kong assures that the scaled down sports schedule on EM TV the past 45 days will gradually rebuild during March. One option for future coverage conflicts with ESPN: "Some form of 'soft' scrambling used only when we have coverage that conflicts with ESPN."

Cook Islands Broadcasting, acquired by 7 Network (Australia), is another possible home for a "Pacific Regional Service." Competitor 9 Network (Australia) operates PNG's EM TV and 10 Network execs are openly discussing creating an international feed of their own as well. In short term, look for 7 Australia to use I180 for feeds into Cooks.

Radio Television Portugal (RTP) schedules more than 80 European soccer (futbol) games each year, one of the largest sporting packages from Europe. Their AsiaSat 2 signal began regular transmission at 9AM UTC January 28 using a full analogue transponder (9A, vertical; 1170 IF). Problems: Signal is 4 to 5dB below expectations in Pacific, audio is "muddy" although J17 format; audio will probably get better, signal level will not and AsiaSat is very quiet about why. RTP radio will be on audio sub of 7.2MHz in mid-March

RTP's Channel 9A (Vt) signal may not be only "problem transponder" on As2. AsiaSat is ducking queries from users who are testing (often only with unmodulated carriers at press time) and finding their levels are NOT what they were promised.

Shaheen Pay TV, Pakistan, is the newest AS2 36 MHz wide transponder user. SPTV is a pay television company and the feed will serve cable TV headends and DTH systems with a scheduled start during February; format unknown.

STAR TV's analogue encryption system is known as "Newscrypt," designed by Schlumberger and adapted by NDC. The B2P system is "fixed key" which means no "Smart Card" is required for access. All AS2 analogue STAR transmissions will require the card. DVB Compliant MPEG from STAR is "likely to be encrypted" according to a STAR source. The same source says, "Galaxy IRDs have the wrong conditional access (CA) sequence to allow use of the Galaxy receiver(s) on AsiaSat 2." Not everyone agrees with this statement.

RFO Tahiti will not only remain on I180 in FTA analogue but plans to add 2nd channel of programming (RFO 2) late this year, says Raymond Wohler of Papeete. Additionally, there is talk of creating a Tahiti fed multi-channel French language DTH and cable pay service programme package on a C-band satellite capable of reaching ALL of the Pacific region.

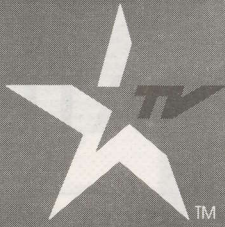

STARnet™

THE ON-THE-GROUND DISTRIBUTION NETWORK OF STAR TV...

STARnet is a global partnership of quality equipment manufacturers, reputable distributors and trained installers. STARnet provides the technology and hardware equipment to satisfy all of the STAR TV network, and can supply PAY TV installers in Australia with equipment suitable for the Australian market. STARnet and STARnet Appointed Distributors have the leading edge to provide access to the new digital age.

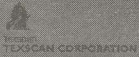

ONE STOP HARDWARE SHOP



- ◆ Cable TV Distribution Equipment
- ◆ Professional Headend Equipment
- ◆ Connectors
- ◆ Drop and Trunk Cable
- ◆ Power Supply
- ◆ Traps
- ◆ Passives
- ◆ Receiving Equipment
- ◆ Cable TV Tools
- ◆ Satellite Antennas



Receivers



Feedhorns



Connectors



STARnet™



Satellite Antennas



If you would like to be an endorsed STARnet installer/dealer, or would like to receive further information about STARnet please contact:

Head Office: 183 Burwood Road, Hawthorn Victoria, P.O. Box 488 Hawthorn, Victoria, Australia 3122

Phone: (03) 9819 2466 Facsimile: (03) 9819 4281

NSW Office: 4/411 Church Street, Parramatta N.S.W. Australia 2151

Phone: (02) 630 0888 Facsimile (02) 630 8690

CABLE TV

Is there money at the end of this hole?



Building a cable television system is a gamble. Conventional bank financing won't touch cable TV because they don't understand it.



Perhaps we can help. In 35 years we have designed and built 57 cable TV systems ranging from 2km to 750km in size. And along the way we've learned a few tricks to reduce the risks.



Our services are available for a flat fee per kilometre of cable plant; we offer the option of taking an equity position in your cable system in lieu of direct payment.



Best of all, our 34 channel Doubtless Bay Cable system can serve as a model for your own.

Come and visit.

Far North Cable TV Ltd.

tel 64-9-406-0651

fax 64-9-406-1083

HARDWARE EQUIPMENT PARTS

UPDATE

FEBRUARY 15, 1996

Amongst interesting new products shown at SPRSCS '96 was the "Surface to Surface" directional drilling system from Taupo Cablevision, Inc. (TCI). The concept is that you mark a starting point and a finishing point and the machine creates a "tunnel" between the two points through which you can pull cable. This ends having to disturb the surface to dig up lawns, streets and other barriers between points where coaxial cable comes back to the surface for above ground equipment (taps, couplers, amplifiers et al). TCI's Ron Theaker is using the unit to build the new Taupo Cable TV plant and believes he will achieve up to 500 metres of undergrounding per week (TCI, tel 64-7-377-0024; fax 64-7-377-0025).



Equally interesting from TCI was a PC/XT/286(+) cable TV subscriber data base and automated billing system called SubTRACKER at US\$599 for a cable system of up to 500 subscribers per community. The automated system ends manual subscriber record keeping, provides end of month operational reports, debt management, preparation of subscriber invoices and income analysis.

Best size dish for plurality of new C (and Ku) services? With AS2 signals in analogue "looking good" on 2.4m quality antennas across Australia and New Zealand, many are betting the 3m dish barrier may be broken by selecting high accuracy 2.4 size dishes. Simultaneously, Australia's Galaxy service on Ku is finding the Paracclipse 1.8 and 2.4m "Hydro-form" antennas make it possible to push the fringe area of the present "banana beam" well in-land. Tests done with a Galaxy decoder during SPRSCS '96 in Auckland suggest a 2.4m Hydro may work in at least favoured portions of New Zealand as well although without a rain fade margin (21 Galaxy programme channels were found during the test).

Mark Long's VHS PAL (or optionally NTSC) training video, "The New Age of Digital Video Compression," is a must for corporate and other serious users of MPEG video systems. Long has agreed to create an infield correspondence course to be available to SPACE members in latter half of this year; students will have full training manuals, video tape aids, complete course segments with exams to be graded by SPACE/Long and be awarded certificates of completion and achievement. Details in April edition of SPACE Member Newsletter.

Best receiver of (SPRSCS) Show? Asian made, costing under NZ/A\$200, unit brought in by Geoff Dargie of Nationwide Antenna Systems (Brisbane) produced most watchable picture and listenable sound on ATM-Prime feed through 1.8m mini dish used by test co-ordinators Barry Ward (right, photo; Dargie in centre) and Robin Colquhoun. There were some red faces at this result!



ADL[®]

BECAUSE PERFORMANCE IS ALWAYS YOUR FIRST PRIORITY

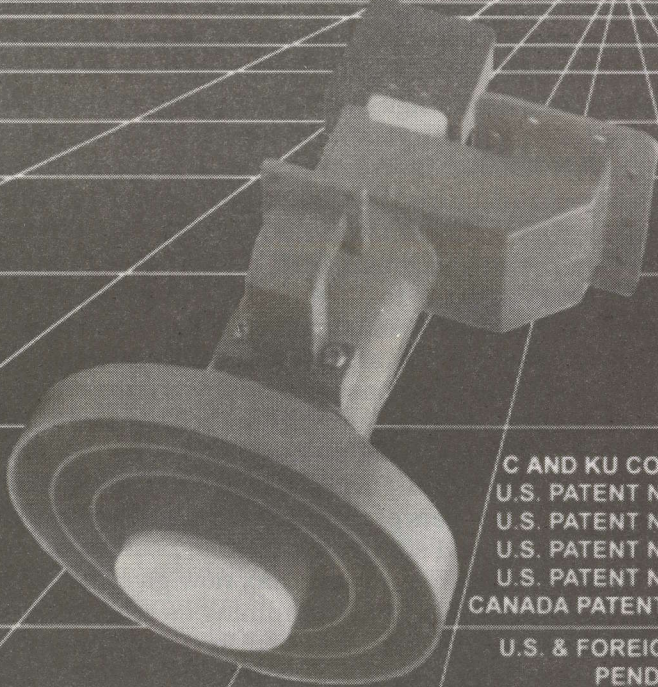

**RP3-CKU/ International
Adjustable Scalar Ring Feed
with Extended C Band**

C AND KU CO-BORSIGHT
U.S. PATENT NO. 4,903,037
U.S. PATENT NO. 5,066,958
U.S. PATENT NO. 5,107,274
U.S. PATENT NO. 5,255,003
CANADA PATENT NO. 1,328,922

**U.S. & FOREIGN PATENTS
PENDING**

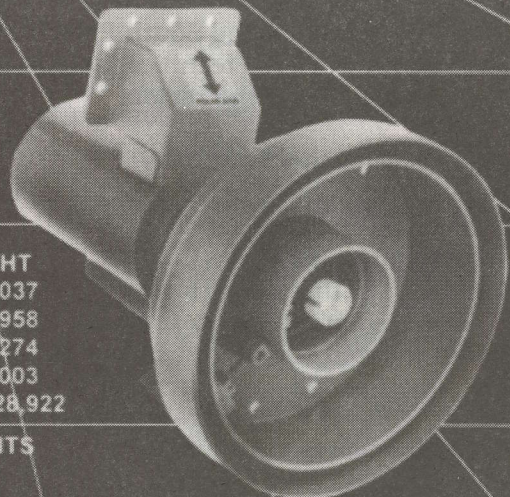

RPI-CKU Feed

ADL HYBRID MODING CIRCULAR POLARIZED INTELSAT FEEDS WITH EXCLUSIVE T.I. REJECTION



RP1-CP400

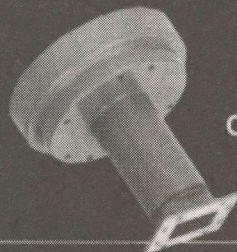

CP-300



CPOR-100

- C BAND LINEAR & CIRCULAR • C/KU LINEAR & CIRCULAR • KU 12 GHz FEEDS
- INTELSAT 4 GHz CIRCULAR • ARABSAT S BAND FEEDS

OPTIONAL: CO-BORSIGHT S BAND

2216 AGATE COURT, UNIT B, SIMI VALLEY, CALIFORNIA 93065 • (805) 526-5249 • FAX (805) 584-0634

ON THE THRESHOLD OF A DREAM

The Latest Up-And-Coming Regional Satellites Are Poised to Dramatically Transform The Realm of TV Entertainment in Asia, Australia, New Zealand and the South Pacific.

by Mark Long in Thailand

Presented at South Pacific Cable & Satellite '96

The direct-to-home (DTH) satellite market in Australia, New Zealand and the South Pacific will soon be dramatically transformed through the launch of several new satellites and the parallel announcement of new satellite TV services for various markets throughout the Asia/Pacific region. Although most of these new satellites have been designed to primarily serve markets in Asia, signals in many cases will be receivable at locations in Australia, New Zealand and the South Pacific. The following report provides the technical details on what will soon be available in the region.

Asiasat 2: Extend the Boundary!

On November 28, 1995, a Chinese Long March 2F rocket deployed the new satellite on behalf of Asia Satellite Telecommunications Co., Ltd. of Hong Kong. Called AsiaSat 2, this new "Hot Bird" for the Asia/Pacific region embraces 53 countries within its C-band footprint and therefore can potentially serve over 3.3 billion people or 63 percent of the world's population. This new spacecraft already is on station at 100.5 degrees east longitude.

AsiaSat 2 carries twenty-four C-band (3.62 to 4.2 GHz) transponders (twenty with a bandwidth of 36-MHz and four with a bandwidth of 72-MHz) and nine 54-MHz-wide Ku-band transponders. The satellite's C-band footprint is designed to provide extensive, high-powered (55-watts per transponder) coverage from Eastern Europe to Far East Russia and from Japan to Australia and even portions of New Zealand, albeit at very low elevation look angles.

On the Ku-band side (12.2 to 12.5 GHz), AsiaSat 2's narrower coverage beam focuses on the People's Republic of China, Hong Kong, Japan, Korea and Taiwan. Although the new satellite uses powerful 115-watt Ku-band amplifiers, any reception in Australia or New Zealand will depend on the uncertainties of satellite sidelobe spillover.

In December of 1995, AsiaSat 2 began transmitting a "Season's Greetings: Extend the Boundary" test card which could be received throughout the wide expanse of the spacecraft's C-band footprint. Just what can we expect in the way of future programming?

A new Asia/Pacific STAR

In 1994, STAR TV snapped up the rights to a total of eight C-band and three Ku-band transpon-

ders on AsiaSat 2. Sometime between now and April of 1996, STAR TV is scheduled to begin transmitting at least one multi-channel, digitally-compressed TV program package to Indonesian homes, with additional packages for other Asian markets to follow. STAR TV's new "DigiSTAR" TV delivery system will eventually transmit about fifty pay TV services through AsiaSat 2. The DigiSTAR IRDs, which are being manufactured by Pace Micro Technology Ltd., will be fully compliant with the MPEG-2 Digital Video Broadcasting (DVB) standard.

STAR TV intends to customize its new digital services to achieve the maximum possible viewing audience in each of its target markets. To achieve this goal, the Hong Kong based company is entering into partnerships with local programmers—exactly the opposite of the original plan developed by previous STAR TV owner Hutchvision, which called for marketing just two sets of channels throughout AsiaSat 1's northern and southern coverage beams.

"The pan Asian approach has now given away to an emphasis on local programming as regional programmers recognised the need for local content if their programs were to enjoy lasting appeal," says Peter Jackson, CEO of Asia Satellite Telecommunications Co., Ltd. in his introduction to the new Asian edition of *The World of Satellite TV*. "In this heady mix of politics, business and technology we will increasingly see new alliances between regional and national programmers."

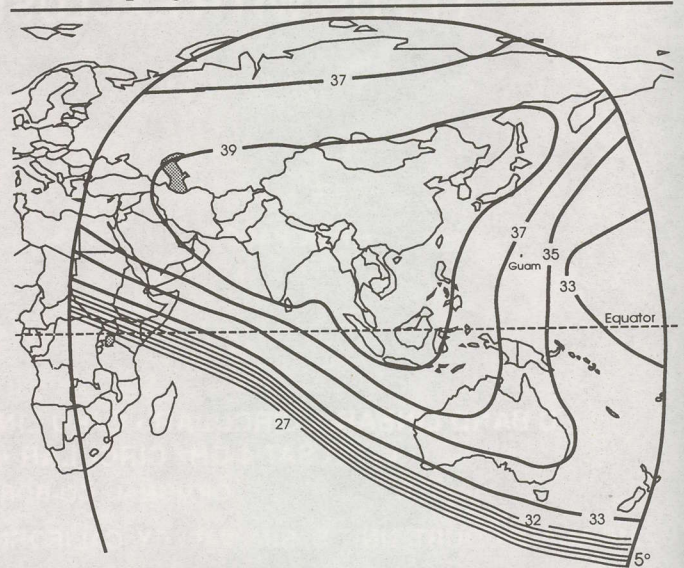

Above: AsiaSat 2 C-band coverage beam.

At least five different clusters of STAR TV program services are now under development, with each cluster featuring a major Asian language. Indonesia will be the proving ground for the new STAR TV digital service. STAR TV and PT Matahari Lintas Cakrawala—Indonesia's sole pay TV licensee—will soon be offering a package of fifteen digitally compressed TV channels designed specifically for audiences in Indonesia, including movie services, music video channels, sports, general entertainment and news programming. The Indonesian company also will begin co-produce local-language TV programming later this year.

But what about Australia and New Zealand? If past satellite history in the U.S.A. is any indication, some entrepreneurs located south of the equator may be trekking to Indonesia to purchase and authorize DigiSTAR IRDs which will then be brought back home as excess baggage. Tens of thousands of VideoCipher IRDs were installed in Central America and the Caribbean during the late 1980s even though these units were only supposed to be used in North America. The point is that satellite signals don't recognize territorial boundaries. As the saying goes: where there's a will, there's a way.

Sniffing out the European bouquet

Reports from the recently completed *Cable & Satellite Asia '95* exhibition held in Hong Kong indicate that Germany's Deutsche Welle Radio and TV is developing a new multichannel digital TV service for AsiaSat 2 which will transmit a "bouquet" of TV and Radio programming throughout the Asia/Pacific region. Deutsche Welle's so-called European Broadcast Bouquet (EBB) would field between four and five TV services, as many as a dozen European radio networks and a data channel. TV programmers would include Deutsche Welle TV, TV5 France, and RTVE Spain. But final contracts have yet to be signed.

A second European programmer—Portugal-based Marconi Global Communications—will use AsiaSat 2 to broadcast RTPi,—the Portuguese International Television Channel—and Portuguese radio service Antena 1. RTPi intends to use AsiaSat 2 to reach Portuguese-speaking people in Asia, including 70,000 in Australia, 160,000 in Japan, and Macau, Timor, Goa and Malacca.

In addition to serving new DTH and cable TV markets in Asia, AsiaSat 2 will provide two international news organizations with digital satellite links. Associated Press Television (APT) and Worldwide Television News (WTN) have each acquired 9 MHz segments of C-band capacity for the digital transmission of TV news programming on a daily basis.

Also on tap are new digital radio services for the BBC World Service which will be part of the BBC's new digital Global Distribution System (GDS) radio service. As many as fifteen stereo radio services will be available in thirteen different languages, including English. The primary aim of this new service is

to feed shortwave transmitter sites and authorized rebroadcasters equipped with 2.4 meter antennas. No plans for DTH reception have been announced to date.

PanAmSat Goes Hindi

Launched on August 3, 1995, on behalf of the privately-owned international satellite operator PanAmSat, PAS-4 already is fully operational at the orbital location of 68.5 degrees east longitude. PanAmSat's new communication satellite is a dual-band spacecraft carrying sixteen C-band and twenty-four Ku-band transponders. On C-band, twelve 34-watt transponders are available with a bandwidth of 54 MHz as well as four transponders with a bandwidth of 64 MHz, while on Ku-band, the spacecraft features eight 54-MHz-wide transponders and sixteen 27-MHz-wide transponders. All Ku-band transponders feed into powerful 63-watt amplifiers.

PAS-4 features three regional C-band beams covering Africa (1); India and the Middle East (2); and an area stretching from eastern Asia to northern Australia (3). On the Ku-band side, PAS-4 carries five distinct regional beams covering southern Africa, India, the Arabian peninsula, eastern Europe, and northeast Asia. No primary beam coverage of Australia is available and the satellite is below the horizon in New Zealand.

Here in Thailand, a total of eight TV signals have been observed to date using the C-band Asia/Australia Downlink Beam. All signals are well above receiver threshold here using a 1.8 meter dish. Major international programmers with, in some cases, the assistance of India-based broadcast partners, have developed these

new regional services for the Indian market. These include ESPN India, Asia Business News (ABNi), Sony Entertainment's new Hindi channel, MTV—Asia, CNN International, Turner Network Television/ The Cartoon Network and Jain TV.



Above: PAS-4 Southern Asia Downlink Beam.

Japan's satellite gambit

On August 29, 1995, Tokyo-based Japan Satellite Systems Inc. (JSAT) launched its new dual-band JCSat 3 satellite to an orbital assignment of 128 degrees east longitude. While all previous Japanese communications satellites have served a purely domestic function, JCSat has been expressly designed

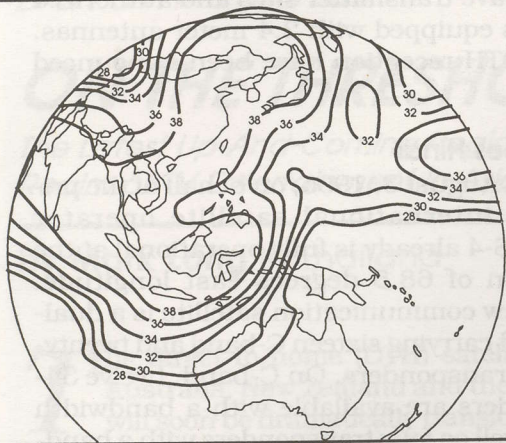

Top Left: JCSat 3 C-band coverage beam, horizontal polarization.

time of writing, the only viewable signal here in Thailand has been a C-band test pattern.

1996 Asia/Pacific Launches On Tap

The AsiaPacific's 1996 launch schedule is chock full of powerful new satellites: Palapa C1 (Lockheed Martin Atlas II), Measat 1 (Arianespace), Apstar 1A and INTELSAT 708 (Chinese Long March) are all scheduled for deployment in the first quarter of 1996, with Palapa C2 (Lockheed Martin Atlas II) and INTELSAT 801 scheduled to follow suit in the second quarter. In the latter half of the year, INTELSAT 802 and 803—as well as Measat 2 and Thaicom 3—will be placed into orbit by Arianespace, with Apstar 2R to be launched by a Chinese Long March rocket.

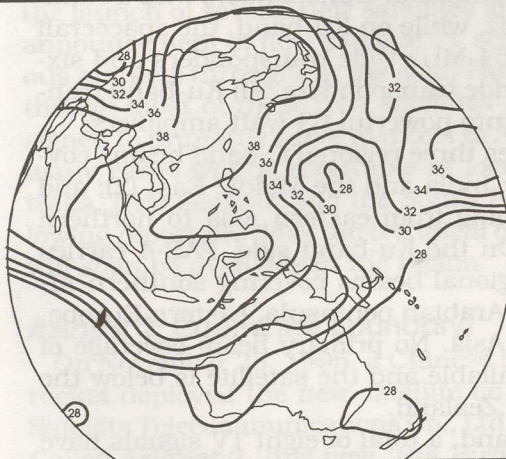

Middle Left: JCSat 3 C-band coverage beam, vertical polarization.

Palapa: an encore performance

Scheduled for a January, 1996 launch, Indonesia's Palapa C1 will replace the Palapa B2P satellite located at 113 degrees east longitude which has ceased north/south stationkeeping due to a lack of on-board fuel. Most of the regional programmers on Palapa B2P, including ESPN, Australia TV International, CNBC-Asia, HBO, CNN International, STAR TV,

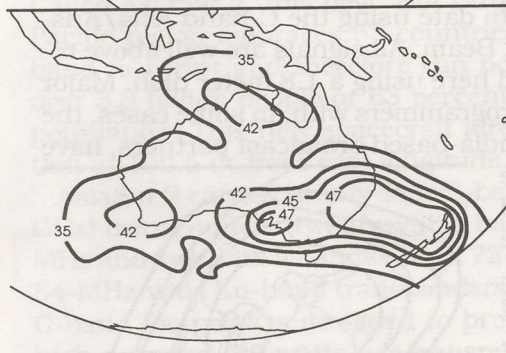

Bottom Left: JCSat 3 Ku-band Australia/New Zealand coverage beam, horizontal polarization.

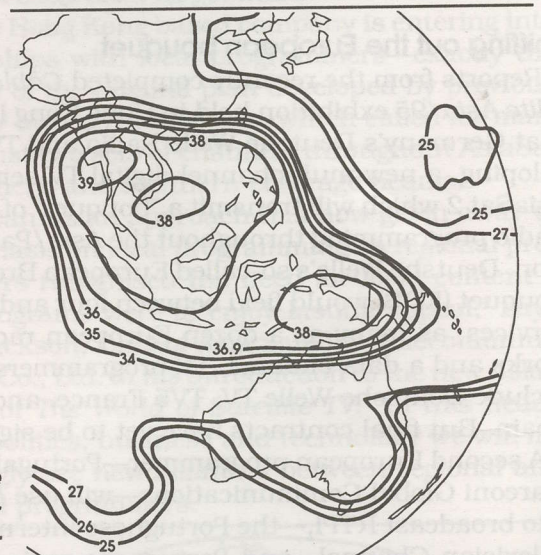

Right: The Two "Standard" C-band coverage beams available from Palapa C1.

to provide regional telecommunications services. Prior to launch, the Japanese Ministry of Telecommunications had completed the required international coordination of the satellite with the telecom administrations of other countries in the region. On a parallel track, the Japanese government took the first step down the road toward liberalizing its restrictive satellite policies by granting landing rights to PanAmSat's PAS-2 and PAS-4 satellites so that its own forthcoming efforts to gain reciprocal landing rights in other countries would be seen in a better light.

JCSat 3 provides four primary coverage beams: Ku-band (12.2 to 12.75 GHz) beams centered over mainland Japan and Northeast Asia (1), India (2), and Australia/New Zealand (3); and a C-band (3.94 to 4.2 GHz) beam that stretches from Japan to southeast Asia to most of mainland China and India. A total of twelve C-band and twenty-eight Ku-band transponders are carried by this spacecraft. At the

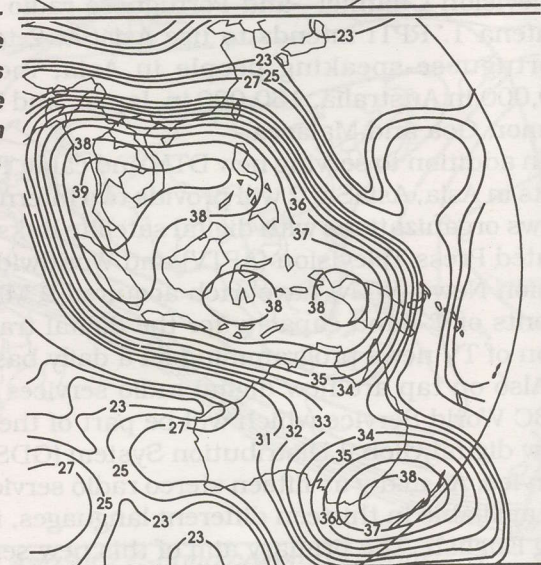

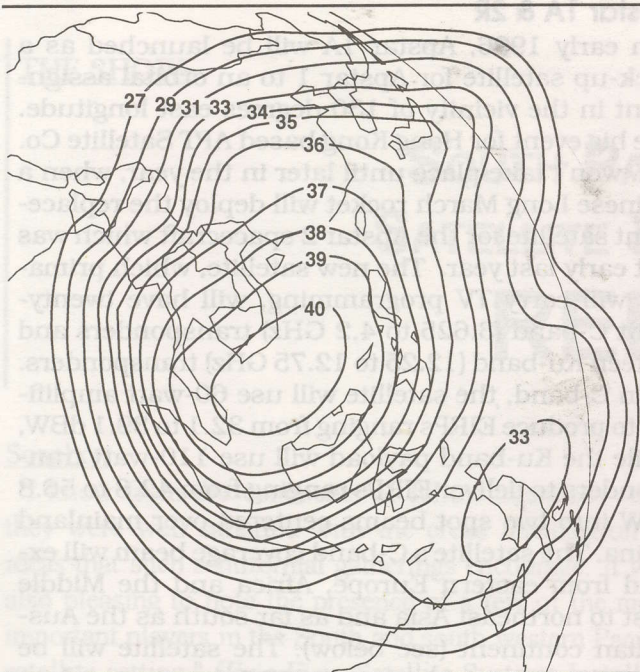

Above: Measat 1 C-band regional beam coverage.

Canale France, Discovery Channel, ABN, and national broadcasters from Indonesia, Malaysia, and the Phillipines, will migrate to the new Palapa C1 spacecraft.

Palapa C1 will carry thirty C-band transponders, each with a bandwidth of 36 MHz, and four Ku-band transponders, each with a bandwidth of 72 MHz. Palapa C1 will not only transmit using the conventional C-band frequency spectrum of 3.7 to 4.2 GHz but also within a lower range of frequencies extending from 3.4 to 3.68 GHz. The Ku-band frequency spectrum to be used by Palapa C ranges from 10.95 to 11.7 GHz.

Palapa C1 will carry two "standard" C-band beams, one focused on Southeast Asia—with secondary low-level EIRP (27 to 34 dBW) coverage into most of Australia, and the other ranging from Southeast Asia to as far south as eastern Australia and New Zealand. As many as twenty-four of the satellite's thirty transponders will operate through one of these two available standard beams. A minimum of six additional C-band transponders will connect to an "extended" C-band beam which will provide excellent coverage of the Asian continent from Japan and Korea in the east, to India in the west and Malaysia in the south. Palapa C1's two Ku-band beams will encompass Guam, Hong Kong, Japan, Macau, Singapore, Malaysia, Taiwan and Thailand.

Measat 1 & 2

Binariang Sdn Bhd of Kuala Lumpur, a joint venture between local Malaysian shareholders and American "baby bell" USWEST, will operate the Malaysian East Asia Satellite (MEASAT) system. MEASAT-1 is scheduled to be launched by Arianespace in January of 1996 to 91.5 degrees east longitude, with a second spacecraft, MEASAT-

2, to be launched by Arianespace in the latter half of 1996. Both satellites are manufactured by U.S.-based Hughes Aircraft.

MEASAT-1 will carry twelve C-band and five Ku-band (10.95 to 11.2 GHz and 12.25 to 12.37 GHz spectrums) transponders. The satellite's C-band footprint will provide high power coverage into most of East Asia, with lower level EIRP coverage as far south as northern Australia and Papua New Guinea.

The MEASAT-1 satellite's high-power Ku-band beam is focused onto Malaysia, where it will be used to transmit a package of digitally-compressed TV channels to antennas as small as 50 cm in diameter. The spacecraft also has the option of switching beam coverage of selected Ku-band transponders to provide additional coverage of the Phillipines and/or India by ground command.

MEASAT-2 has been designed to provide back-up capacity for MEASAT-1 as well as deliver additional capacity and expanded regional coverage. MEASAT-2 will carry six C-band transponders covering the East Asian region and ten Ku-band transponders capable of duplicating the MEASAT-1 Ku-band coverage, with the tantalizing addition of new spot beams centered over Vietnam, Indonesia and Queensland, Australia.

Thaicom 3

Shinawatra Satellite Public Co., Ltd., operator of the Thaicom 1 and 2 satellites for the Kingdom of Thailand, is constructing two additional satellites, Thaicom 3 and 4, which will be used to provide regional satellite communications services throughout the Asia/Pacific region. Both satellites are being manufactured by Aérospatiale of France. Thaicom 3 is scheduled for a late-1996 launch to 78.5 degrees east longitude.

The three-axis stabilized Thaicom 3 and 4 satellites will have a much larger communications pay-

Below: Thaicom 3 C-band "global" beam coverage.

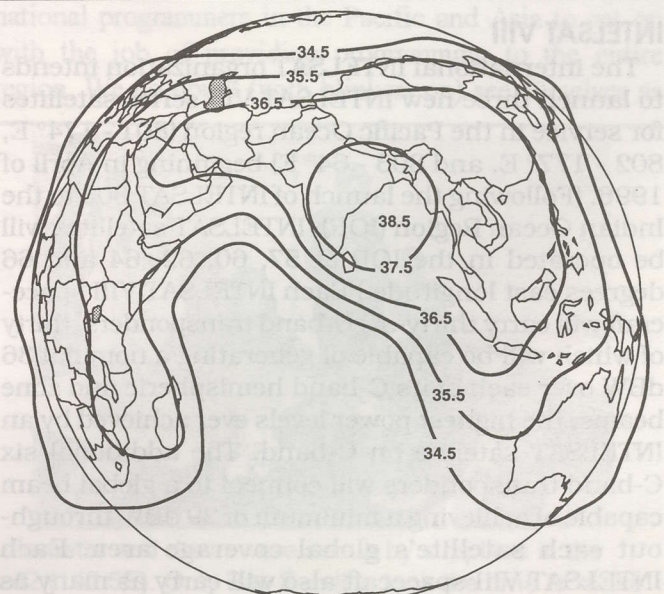

Below: INTELSAT VIII Pacific Ocean Region coverage will feature "hot" hemispheric and zone coverage beams with a nominal beam-edge EIRP of 36 dBW.

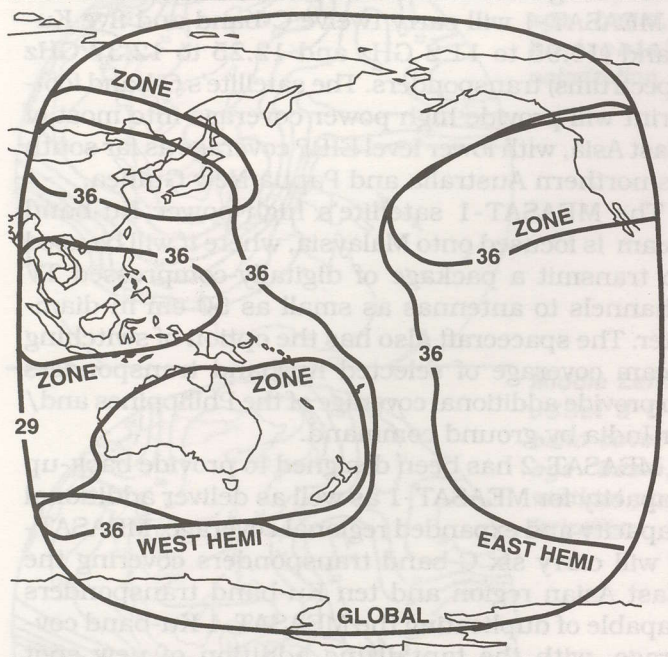

load than the current spin-stabilized Thaicom 1 and 2 spacecraft. Each new satellite will carry twenty-four medium-power C-band and twelve high-power Ku-band transponders.

Thaicom 3 will provide C-band coverage that will span four continents: Asia, Europe, Australia and Africa. Ku-band coverage will include a high-powered beam illuminating Southeast Asia, and a steerable beam that can be used to provide direct-to-home (DTH) TV transmissions to other countries such as India, where Shinawatra is working to establish a consortium for the introduction of a digital DTH service on Thaicom 3. According to Shinawatra, Thaicom 3 will be able to provide 60 to 70 digital TV channels to 60cm antennas located within most of India's major cities.

INTELSAT VIII

The international INTELSAT organization intends to launch three new INTELSAT VIII series satellites for service in the Pacific Ocean region (801 - 174° E, 802 - 177° E, and 803 - 64° E) beginning in April of 1996. (Following the launch of INTELSAT 803 to the Indian Ocean Region (IOR), INTELSAT satellites will be operated in the IOR at 57, 60, 62, 64 and 66 degrees east longitude.) Each INTELSAT VIII spacecraft will carry thirty-six C-band transponders, thirty of which will be capable of generating a nominal 36 dBW over each of its C-band hemispheric and zone beams, the highest power levels ever achieved by an INTELSAT satellite on C-band. The additional six C-band transponders will connect to a global beam capable of achieving a minimum of 29 dBW throughout each satellite's global coverage area. Each INTELSAT VIII spacecraft also will carry as many as six Ku-band transponders.

Apstar 1A & 2R

In early 1996, Apstar 1A will be launched as a back-up satellite for Apstar 1 to an orbital assignment in the vicinity of 130 degrees east longitude. The big event for Hong Kong based APT Satellite Co. Ltd. won't take place until later in the year, when a Chinese Long March rocket will deploy the replacement satellite for the Apstar 2 spacecraft which was lost early last year. The new satellite, which primarily will carry TV programming, will have twenty-eight C-band (3.625 to 4.2 GHz) transponders and sixteen Ku-band (12.25 to 12.75 GHz) transponders.

On C-band, the satellite will use 60-watt amplifiers to produce EIRPs ranging from 32.1 to 39.1 dBW, while the Ku-band payload will use 110-watt transponders to deliver EIRPs ranging from 42.8 to 56.8 dBW into two spot beams centered over mainland China. The satellite's C-band coverage beam will extend from eastern Europe, Africa and the Middle East to northeast Asia and as far south as the Australian continent (see below). The satellite will be located in the neighborhood of 77.5 degrees east longitude. The actual final orbital location will depend on the outcome of negotiations with other satellite operators with spacecraft which operate at nearby orbital locations.

Several regional programmers already have collectively booked sixteen transponders on the new bird. CNN International, ESPN International, Discover Communications, Viacom Networks, Time Warner and TVB International have plans to adopt common encryption and compression standards to permit the use of common sales and marketing strategies for DTH and cable TV distribution services.

(The satellite coverage maps presented in the above article are from *The World of Satellite TV* by Mark Long © 1995 MLE INC.)

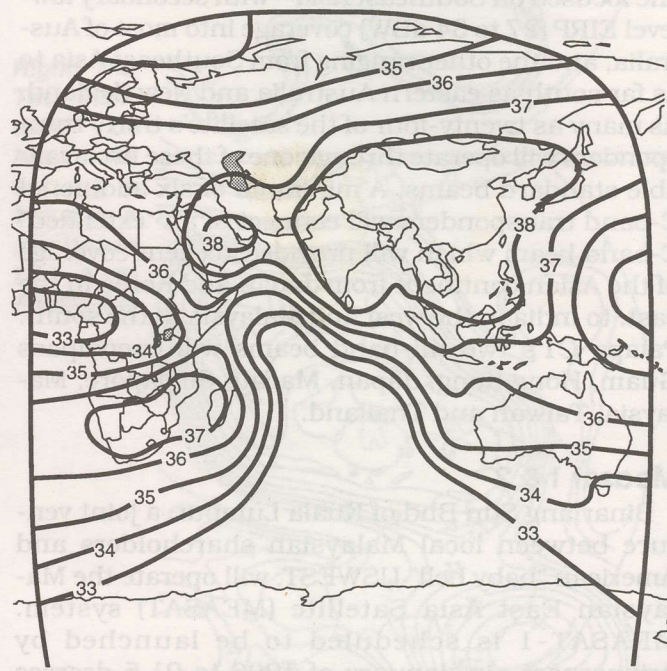

Above: Apstar 2R C-band regional coverage from 77° East.

THE SHOW-

SOUTH PACIFIC REGION SATELLITE & CABLE SHOW REPORT

Soapbox

"I know from the comments of fellow attendees that they were well satisfied with the cross fertilisation of ideas that such semiformal gatherings encourage. It was also pleasing to note the presence of a few of the more important players in the South and south western Pacific satellite setting." (*Eric Fien, Satellite Systems Installers Australia*)

"Excellent trade and training show for SPACE's first one and I can see a good future for these style events in both New Zealand and Australia." (*Mick Cameron, Melbourne Satellites*)

"I attended the Optus seminar and was blown away with prices and services offered ... between AU\$1500 and 3500 per month gets transponder SCPC/MCPC space segment. I then met with Ron Theaker from Taupo Cablevision and he told me there are VSAT terminals available (64 kbps expandable to 256 kbps) on the used US market for US\$6000. With the Waikato University increasing its terrestrial rates substantially to try to keep the demand for Internet in check, what I see here is a wonderful business opportunity to launch a VSAT based competitor." (*Tim Alderman, Oakland, Ca.*)

"Great show, it brought the right people together and now we can all fight for software as a unified body with

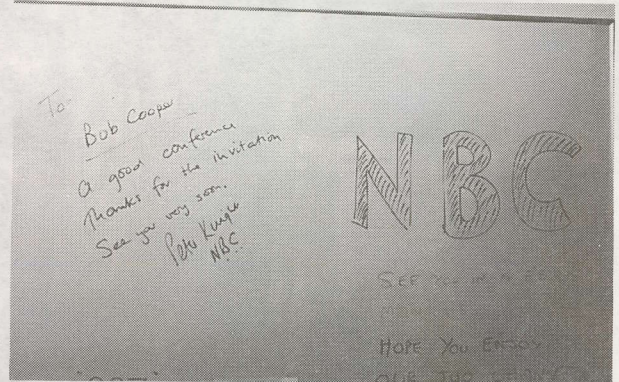

NOT QUITE in stone. NBC Asia's Peter Knight left this message on his wall chalk board at show's end ("TO Bob Cooper: A good conference, thanks for the invitation, see you very soon.") Thank you, Peter, for helping make it a "good" show.

support from throughout the Pacific." (*Steffen Holz, Studio 7, New Caledonia*)

"I am sure it would not be out of place to state that the awesome push by Deutsche Welle into the Pacific (as well as the other European programmers they will bring along with them) will be of immense importance to all users of satellite signals. As well, what they are doing is a rather pointed barb directed at our own so-called national programmers in the Pacific and Asia to get on with the job of providing programming to the entire region. We no doubt (with blinkers on) see ourselves as

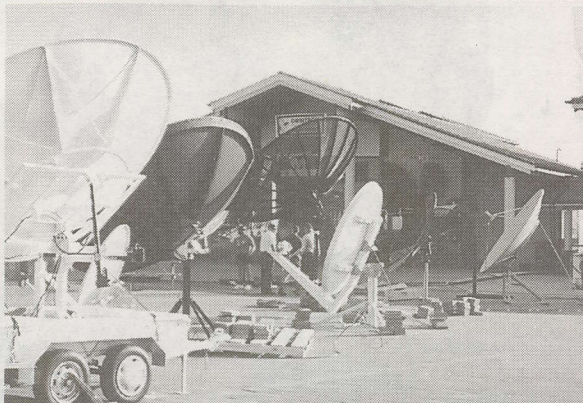

OUTSIDE / INSIDE. 15 C or C + Ku dishes from 4.5m diameter and down were set up by suppliers in the antenna lot, most were fixed on PAS-2, Gz41 (130E) or Gz42 (142.5E). Only Bay Satellite took the time to make their dishes track the full arc and one of their 3.8m models fed into the Technician & Testing Centre where technical types did direct receiver performance testing through the four day period (right hand photo). The exchange of experiences, ideas and concepts was pervasive through the entire show.



PETER SWAIN in the Telsat Communications stand just minutes before the doors opened on Saturday for "Public Day." Thousands turned out to learn about DTH service for the first time.

being quite an important 'market' for DW, yet in reality their push is into the exploding economies of east and Southeast Asia with Australia and New Zealand just being lucky beneficiaries of this activity." (Eric Fien)

"Thanks for a great show - I am certain everyone who attended got a lot out of it. The only negative I heard were complaints that the cafeteria did not have much of a variety of food available. Setting that small beef aside, the Open Public Day was a huge success - next year we will be more fully prepared for the hordes of people attending." (Selwyn Cathcart, Telsat Communications)

The Revelations

When would there be DVB Compliant MPEG? Curious attendees wanted, needed, to know. Cynthia Dickins from PanAmSat was on point.

"The PanAmSat system world-wide is adopting to this technology. There is a move to DVB Compliant and for some of our satellites it will come sooner, for some later."

Dickins suggests that while PanAmSat does view its world network of satellites as "seamless" (i.e., capable of interconnecting any two points on earth through three or four PAS satellites), she would not be surprised if some

PAS satellites used (for example) an S/A MPEG format while others used (for example) an NTL MPEG format.

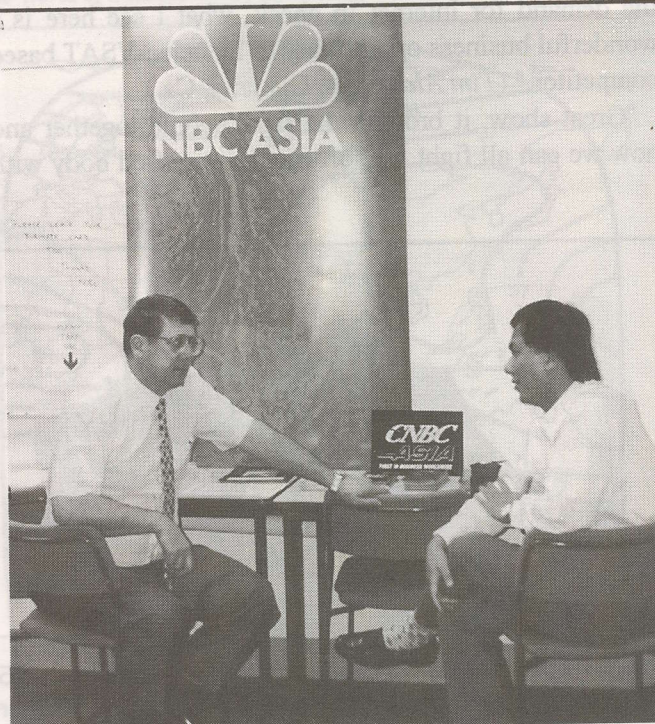

NBC ASIA'S PETER KNIGHT discusses use of the new "super channel" in Malaysia with SPACE Dealer delegate Lim Ching Seng.



ASIAN-origin population turned out by the bus loads at urging of SPACE Dealer Member Danny Deng (Satellite TV Services, Ltd.) and Member Alan Wing (back to camera, right). Their enthusiasm was heightened by appearance of STAR Mandarin service channel on AS2 and show exhibition of quality reception from AsiaSat using dishes smaller than 3m. Grandfatherly Wing, of Chinese ancestry, plans to first-time learn Mandarin through satellite feeds!

Confused? Us too. We think we see the likelihood that some form of S/A format may be used on PAS-2, some



CYNTHIA DICKINS of PanAmSat warned us we should expect more digital - soon, but was cautious concerning whether or not a majority carried by PAS-2 would be "DVB Compliant."

form of NTL on perhaps PAS-4, perhaps even some form of GI on PAS-1 and 3. We are further confused when at least one PAS-2 programmer (Discovery) will shift from B-MAC analogue to GI DigiCipher II in April while another PAS-2 programmer (NBC Asia) is telling affiliates it will switch from its present S/A MPEG 1.5 to an NTL format using PACE receivers in April! All of this on the same bird. No, that does not sound like "DVB Compliant" to us.

Johannes Firsbach left the show with a bit of sage advice from Deutsche Welle: "Get in line now; place your orders for DVB Compliant receivers because they are going to be very difficult to come by for the rest of this year." DW's digital start-up on AsiaSat 2 is delayed at least in part because of shortage of receivers, and totally because of a lack of equipment. The DW service from Europe will be taken down from a European / African satellite at a station in Israel where it will be relayed back to AS2. "For many months," detailed Firsbach, "we thought we would be unable to begin in digital when AS2 was ready because the special digital

The Show - continues page 16

UNCLE BAY SAT says ...



THANK YOU Paraclipse
for building the Pacific Region's
best performing satellite antennas
and for providing the most
comprehensive infield
training and factory implemented
assistance programme - as proven
"under fire" before hundreds
of witnesses during SPRSCS '96!



*And the lucky winner of a Paraclipse 3m
Eclipse DTH system is (Andy Huljich of
Auckland)*



*Paraclipse USA's Norm Bruner adjusts feed on Hydro 1.8m
receiving AsiaSat 2 during SPRSCS '96*

Bay Satellite was the exhibitor to actually demonstrate
AsiaSat 2 at the show - on a range of antennas from 1.8
to 4.5 metres. Plus, Bay Satellite was the exhibitor to
prove AsiaSat 2 reception on antennas as small as 1.8m.

Additionally, Bay Satellite was the exhibitor that
conducted parking-lot antenna assembly courses
(thank you Norm Bruner, Tim Alderman, Jim Roberts
for bringing in your USA antenna experience, Bob
Partain of California Amplifier for your valuable LNB
and feed expertise, and Bay Sat's Stu McLeod for your
in-depth local knowledge!). And Bay Satellite was the
exhibitor to install show antennas that actually tracked
the Clarke Orbit Belt At Bay Satellite TV Ltd we are
deeply involved in helping you understand the mechanics
and electronics of home and professional satellite
systems. This is assistance you can depend upon when
we are your antenna supplier.

**YES! We accept VISA &
Mastercard with NO surcharge!**

BAY SATELLITE TV LTD

PO Box 14050 • Hastings, New Zealand • Tel toll free 0508-DISH-4-U (*)
Int. 64-6-878-9081 • Fax 64-6-878-5994 (* 0508-347-448)
E-mail john@baysat.co.nz



SL-8000RP

4500 years ago, the Egyptians were so far advanced in building technology that the pyramids were considered to be one of the Seven Wonders of the World. Today, still standing, these magnificent shrines to the achievements of man leave us marvelling at the skill and dedication of these ancient people. Fine craftsmanship is truly an ageless art.

Palcom receivers reflect skills and craftsmanship based on the same traditional values. The flagship of the Palcom range, the SL-8000RP is another marvel of technology.

From BC2500 to SL-8000RP

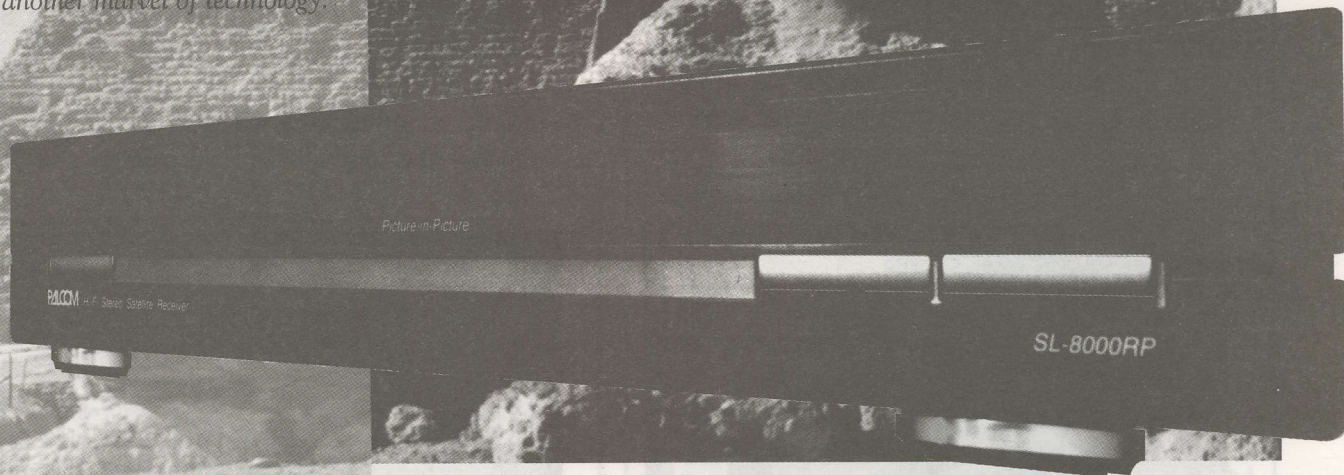

Its unique moving Picture-in-Picture feature permits the viewing of two channels at the same time (on one TV or two) or watching one channel whilst recording another. Mix images from satellite and terrestrial TV, satellite TV with VCR playback or satellite TV and security camera output with a choice of picture size for each image source.

The weakest signals may be viewed using the Palcom low threshold tuning facility producing improved video and audio performance.

A built-in antenna positioner provides access to all current satellites

500 Channels • 2 Tuners • 3 IF Inputs • Weak signal Video and Audio processing • HiFi 1600 • Stereo Audio processing (surround) • On Screen Display in 6 languages • Channel Naming • Satellite Naming • LNB Naming • Decoder Naming • 16 Local Oscillator presets (adjustable) • 22kHz Tone Switching • Global and Fine Ferro/Skew adjustment • Alphanumeric Channel List • Favourite Channel Function • 16 Preset External Decoder configurations • Internal VideoCrypt ready • Timer / Priority switching for TV and VCR

with software by....

PALCOM

State of the Art Simplicity



AWW GO ON! AsiaSat 2 on a 1.8m dish??? Yup, even with the dish barely skirting (4+ degree elevation) through buildings across the parking lot!

uplink equipment in Israel had not arrived. Then as AS2 slipped in launch, we realised that we were ultimately going to be delayed because even if we could begin broadcasting in digital, there wouldn't be any receivers available to see us!"

Will all DVB Compliant receivers be capable of receiving the DW "European Bouquet" programme channels (see p. 23, this issue)? Firsbach told the

conference, "We have been promised that any receiver capable of receiving the (As2) STAR TV programme package will also receive our programme channels."

While we all hope this is true, there are some possible problems with what DW has been promised. The German broadcaster has ordered a modest quantity of broadcast and professional grade DVB Compliant receivers from NTL for the first affiliates in the Pacific and Asia. To be sure, "DVB Compliant" does mean the receivers and the transmission format will "mate" at least for the "European Bouquet" services. But will these DW ordered NTL receivers also function for the STAR TV services?

Unknown.

DVB Compliant is a standard; but only a partial standard. The individual broadcaster is still free, while

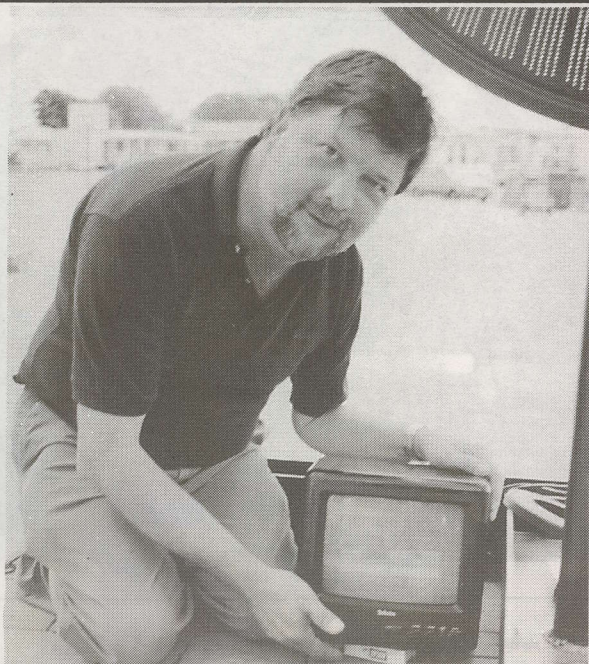

BAPTISM UNDER FIRE. California Amplifier's Bob Partain proudly shows off AsiaSat 2 test card at 1.8m dish in parking lot. "Brother Bob" also performed Baptisms under water during his LNB seminar presentation.

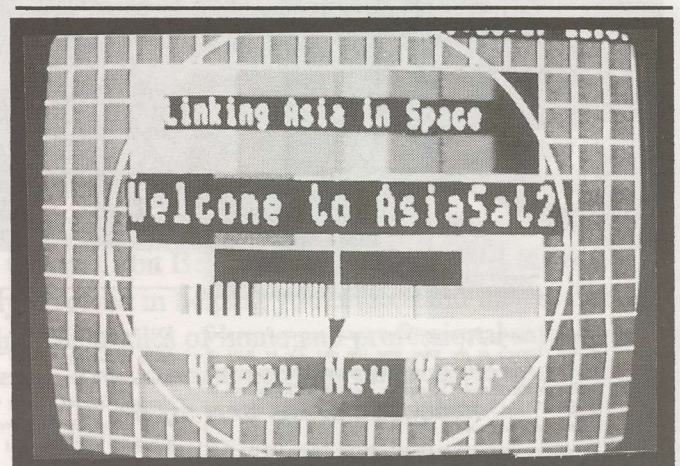

THANK YOU WINNIE PANG and AsiaSat for putting up this test card to assist SPACE SPRSCS antenna builders in teaching the finer points of arc tracking!



MICHAEL FLECK of SPACE member firm GlobalVision did an eloquent job of explaining 'BTV' (business television networking).

using the DVB Compliant (MPEG) "standard," to fiddle with non-standardised parameters so to render useless receivers that cannot cope with this fiddling. STAR TV



JO THOMPSON of Country Music Television announces winner of free 3m dish system with D9222 receiver and year subscription to CMT (Dot Nicholls of Warkworth, NZ). The first person to hug the ecstatic winner shouted, "Can I move into your spare bedroom for a year!" SPACE purchased the prize and donated it to the event to help bring out the public on Saturday.



- Trade supplier of
- Echostar receivers
 - KTI dishes
 - Gardiner LNB's
 - ADL feedhorns
 - other satellite accessories

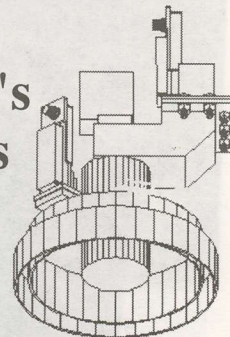

In Australia -



(09) 306 3738



(09) 306 3737

pmerrett@omen.com.au <http://www.omen.com.au/~pmerrett>
33 KENTIA LOOP, WANNEROO, WESTERN AUSTRALIA 6065

NOT COMING TO A NEWSAGENT NEAR YOU!



The new 1996 AV-COMM SATELLITE TV CATALOGUE, contains up to the minute information on all available satellites and equipment needed to receive them.

Contains detailed information on over 200 products covering all aspects of Satellite Television Reception.

For your FREE copy of the new 1996 AV-COMM CATALOGUE simply complete the coupon and send to: AV-COMM PTY. LTD. P.O. Box 225, Balgowlah NSW 2093.

YES Garry, please send me a FREE copy of the 1996 AV-COMM Satellite TV Catalogue.

AV-COMM PTY LTD

A.C.N. 002 174 478

198 Condamine Street,
Balgowlah NSW 2093

Tel: (02) 9949 7417/9948 2667

Fax: (02) 9949 7095

Name: _____

Address: _____

P'code: _____

Phone: () _____



IT GETS EASIER EACH TIME. Bay Satellite's Stu McLeod, perhaps the most talented precision dish system assembler in New Zealand at the present time, knows that dish fine tuning begins with careful step by step assembly. McLeod's skills are second to none in setting a dish to full arc tracking.

may not be above "fiddling" with the data rate or the error correction parameters with the intent of eliminating from receivers sold for STAR the ability to tune-in, for example, the European Bouquet programme channels on

AS2. On Johannes' advice, order your receivers early; as soon as you figure out which receivers to order!

This report continues in SF#20.

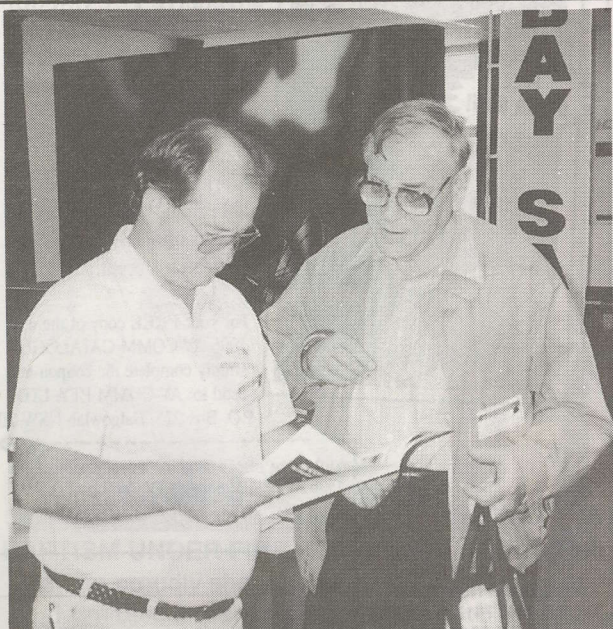

GARRY CRATT (l., Av-COMM) inspects hand delivered copy of The Wireless Primer with author **Glyn Bostick** of Communications & Energy Corp.

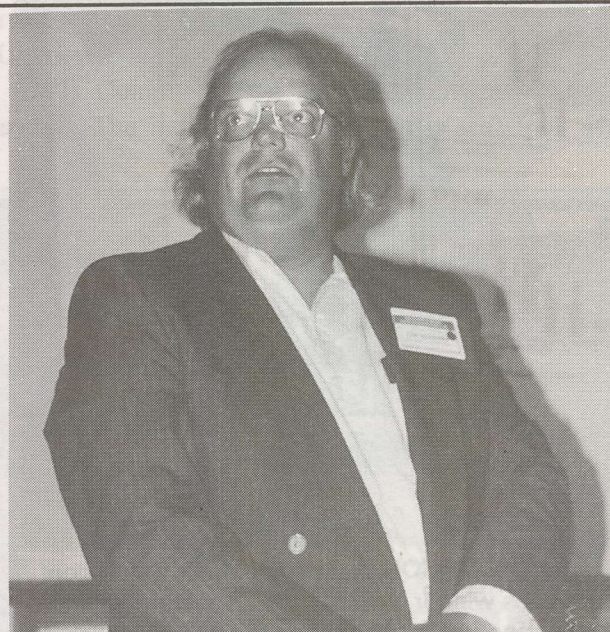

HE CLEANS UP WELL. Dish-pert Tim Alderman in his second NZ visit in 6 months directed assembly of antennas plus organisation of the show antenna lot for SPACE and conducted dish and feed seminars.



AV-COMM SATELLITE TV EQUIPMENT



WORLD SATELLITE TV AND SCRAMBLING

Cat # B1020

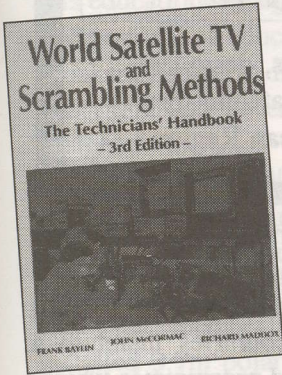

Known as "the technicians' handbook", this text is a must buy for technicians, satellite professionals, and enthusiasts. The design, operation, and repair of satellite antennas, feeds, LNBS and receivers are examined in detail. An in depth study of scrambling methods, and broadcast formats is the backdrop to a discussion of all current American and European satellite TV technologies, including the

Videocypher II, Oak Orion, Filmnet, UK Sky Channel, EuroCypher, D2MAC, BSB and Teleclub Payview III. Circuit and block diagrams of all components are presented and clearly explained throughout the book.....\$79

WIRELESS CABLE & SMATV

Cat # B1011

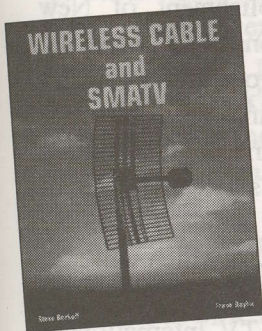

A comprehensive study of the new broadcast method, Wireless Cable, and the closely related field of satellite master antenna TV systems (SMATV). Three chapters are dedicated to details of the site survey, planning and design phases of a private cable system. Off air and satellite headends and all components from antennas to processing and mixing electronics are studied in detail. Ideal for those

considering an MMDS installation.\$89

THE WIRELESS PRIMER

Cat # B1021

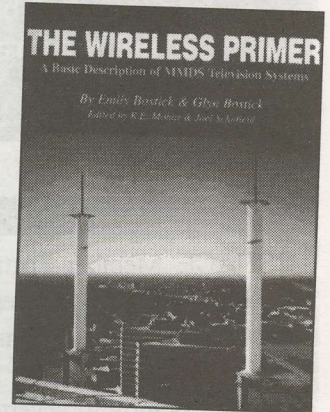

A 76 page complete description of MMDS television systems. This first edition, published in 1995, contains thirteen comprehensive chapters covering all aspects of system design, and shows actual on-air configuration of a 31 channel MMDS system. A valuable reference for anyone involved in installation or maintenance of an MMDS system, "The wireless primer" shows how one operator in the USA saved \$100,000 on hardware by following the designs in this book!!\$45

1995/96 WORLD SATELLITE YEARLY

Cat # B1013

The 768 page 1995/96 World Satellite Yearly contains the latest information about satellites, technology and programming. Features updated chapters on audio and video compression, footprints for satellites launched during 1994 and projected for 1995/96, and worldwide programming assignments. The ultimate reference book on satellite TV footprints, programming and technology.\$140

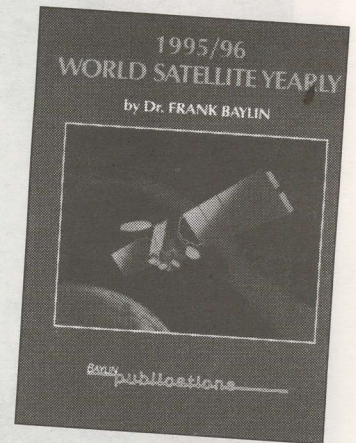

AV-COMM PTY. LTD.

DIRECT IMPORTER ACN 002 174 478
PO BOX 225, BALGOWLAH
NSW 2093 AUSTRALIA

TEL: (02) 9949 7417

FAX: (02) 9949 7095

CUSTOMER BULLETIN BOARD
(02) 9905 0849

LIGHT YEARS AHEAD OF OUR IMITATORS



✓YES GARRY, Please send me

- 1 x World Satellite TV and Scrambling @ A\$79 Plus \$17 Airmail
- 1 x The Wireless Primer @ A\$45 Plus \$6 Airmail
- 1 x Wireless Cable & SMATV @ A\$89 Plus \$23 Airmail
- 1 x 1995/1996 World Satellite Yearly @ A\$140 Plus \$23 Airmail

Order two or more titles and we'll send your shipment freight FREE!!

Credit card No: _____

Signature _____ Expiry Date: __/__/__

Name: _____

Delivery Address: _____

P'code: _____

a technical and marketing advisory memo to the membership from your industry trade association

FEBRUARY 15, 1996

SPACE Pacific

Satellite
Programme
Access
Committ**E**e

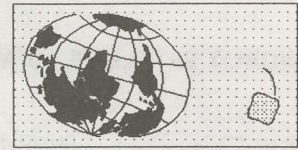

A trade association for users, designers, installers, sellers of private satellite-direct systems in the Pacific Ocean Region

SPACE Member Forums conducted on the closing day of SPRSCS '96 established broad goals and objectives for the coming 12 month period. Both morning and afternoon forum sessions were well attended including several dozen new members who signed up while attending the conference.

Members from Fiji, Tonga, and French Polynesia raised the issue of "Lobbying" the New Zealand and Australian governments to establish specific (South) Pacific satellite services. Both countries maintain a variety of cash, grant and service aid programmes which, it was noted, are often so thinly spread throughout the Pacific region that the beneficiaries are almost impossible to identify. Hot on the heels of the announcement that six European broadcasters, operated by their respective national governments, were pushing their programming into the Pacific (although sadly, not beyond approximately 180E because of the failure of As2 to reach further east), delegates believed the time was opportune to lobby for establishment of New Zealand and Australian "international TV services" throughout the Pacific as a part of an overall Pacific Aid policy. With Japan (NHK), China (CCTV) now available on PAS-2, with French Polynesia recommitting to not one but two FTA analogue TV services (by end of year, I180), and with Palapa C1 about to deliver Malaysia (RTM), the Philippines (GMA which will stay free to air until at least year's end on C1), Indonesia (TV Indostar) and Singapore (Singapore TV International), the negligence of "moving into the modern world" on the part of New Zealand and Australia is abundantly clear.

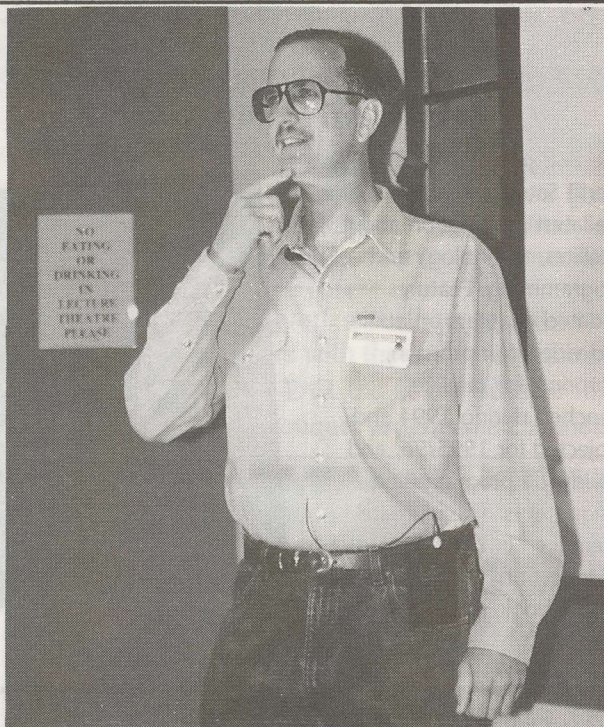

THAILAND BASED Mark Long, during SPRSCS '96. He is structuring a certificate course in C + Ku satellite techniques for SPACE members to be available in last half of this year.

Deutsche Welle's move into Asia and the Pacific on As2 is of course a government funded programme; the German's wisely recognise as Asia and the Pacific Rim are rapidly becoming the largest marketplace in the world for German products and services, that the international outreach afforded by the DW TV service is

WHY BE A SPACE MEMBER ???

Membership in SPACE is optional; people or firms belong because they believe it will benefit their business or private interests in satellite communications. SPACE Members share information relating to many aspects of this industry's growth which is not published in a public forum (such as SatFACTS). SPACE Members are entitled to special discounts from some member firms, and special privileges during the annual SPRSCS Conference (January 21-25 [1997]). Members will also qualify for the "SPACE CERTIFICATION COURSE in SATELLITE COMMUNICATIONS" under the tutelage of instructor Mark Long to be on offer in the last half of 1996. Interested? Use query-card on page 30 here or fax SPACE at 64-9-406-1083.

a "calling card" that opens doors and prepares the people of this portion of the world to accept German companies and products.

Educating New Zealand and Australian government agencies and politicians concerning this oversight will be a major undertaking by SPACE in the year ahead we invite participation by members in a position to make this educational programme work more effectively.

Speaking of education, several of the USA-imported speakers had some harsh criticism of our show antenna lot. Most had never witnessed polar mount antennas, designed to track the full Clarke Orbit Belt, so improperly installed! Sessions conducted by Jim Roberts (Gourmet Entertaining) and Tim Alderman that reduced the arc tracking exercise to its most basic elements seemed only partially effective. One local expert (sadly, a SPACE member) stood directly in front of a properly installed 3.7m polar mounted antenna at the show and expounded his own private theory: "Polar mounting only works north of the equator; down here, you cannot make a dish track the arc!"

Ooops.

Better education, better learning tools, better reference materials seems like a major need to SPACE. Accordingly, we put the final details on a correspondence course programme to be available to SPACE Members by mid-year. Noted author, lecturer, world satellite expert Mark Long is designing this course and will personally review course participants test papers. Mark's 15 years of "teaching satellite" will be woven into the new courses, starting at entry level and working through "Master Installer" with certificates of achievement and course completion issued by SPACE to members who successfully navigate the courses. We are also exploring a system that will allow attendees at SPRSCS '97 to come a day or two early and do an intensive Mark Long 'Cram Course' leading to on-the-spot certification. Hopefully at the '97 Show, nobody who is a member of SPACE will stand in front of a polar mounted dish and proclaim:

"This technique only works when you live north of the equator."

Members also believe that "work shop" sessions put on by specific supplier-engineers should be a part of the 1997 show programme. Bob Partain of California Amplifier was warmly cited for his session approach to the mysteries of LNBS and delegates believe there should be an opportunity for specific technology vendors to do more of this in the future. Also suggested - that at least once per day people be able to sign up for a four hour course in proper antenna assembly, in a structured environment as a workshop project.

As you can see, the discussions were wide ranging and most have already circled January 21-25 in 1997.

RF & MICROWAVE FILTERS FOR ALL TV NETWORKS

MMDS
LPTV
SATELLITE

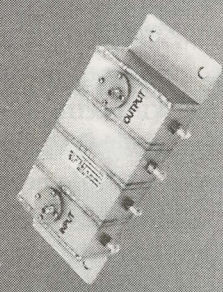

CATV

FILTERS FOR ALL SYSTEM NEEDS

- VHF/UHF Bandpass
- Pay TV Traps/Scramblers
- Off-Air Interference
- Custom Filters



TVRO TERRESTRIAL INTERFERENCE FILTERS AND OTHER SOLUTIONS TO EITHER ANALOG OR OTHER (WIDEBAND) INTERFERENCE.

NEED HELP WITH A SPECIAL PROBLEM?
CONTACT US TODAY!
BE SURE TO ASK FOR OUR CATALOG!

Glyn Bostick and I have served American CATV from its start and developed many of the CATV/Satellite filters now standard in the industry. We are excited at the opportunity to serve the accelerating CATV industry in New Zealand and Australia.

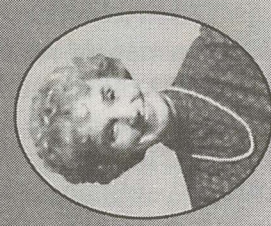

Emily Bostick
President



7395 Taft Park Drive
East Syracuse, N.Y. 13057
TEL: (315) 452-0709
FAX: (315) 452-0732
Canada & U.S. 800-882-1587

New Zealand: 64 09 479 7889
Australia: 61-02 970 7644

THE CABLE CONNECTION

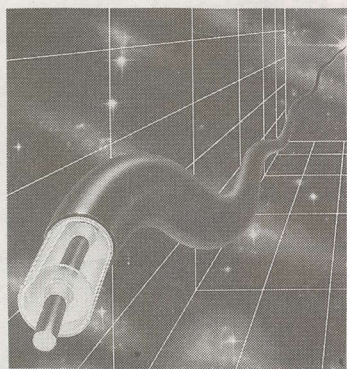

THE FIRST cable TV affiliate agreement in the Pacific for Deutsche Welle, Johannes (John) Firsbach witnesses contract signing with Far North Cable TV Ltd's Bob Cooper during SPRSCS.

Access to cable quality programming was thrust into front row, centre during SPRSCS '96 as the first wave of new-for-cable programmers appeared to describe their products. Simultaneously, there is a rethink of the importance of the Pacific marketplace by many of the established programming sources. It all adds up to important, new cable system opportunities for many communities.

For locations within view of AsiaSat 2, a three dish headend will produce 33 off-satellite services available for cable of which 16 are totally or significantly in English (As2, Palapa C1, PAS-2). A fourth dish adds EMTV (34 / 17) and a fifth adds WorldNet and RFO (36/18). Clearly as of April there will be far more programming channels available than most cable system operators would elect to carry.

Cable rates range from no fee to a top of US\$.85 per month per cable home served. Within this mix there are some attractive offerings; the new NBC (Super Channel) Asia service with cable carriage rights to CNBC included is less per month than Discovery, or TNT/Cartoons, for example.

As described in some detail at SPRSCS, it is possible to build a 48-550 MHz cable plant capable of carrying as many as 67 analogue programme channels in the forward direction for NZ\$10,400 per kilometre of buried cable plant, all parts and labour inclusive. Such a plant passing 30 homes per kilometre will have NZ\$347 per passed home invested whereas with 50 homes per kilometre the cost per home passed drops to \$208. SPRSCS lecture notes detailing these numbers in a system now operating are included in the March SPACE Membership Notes.

A community with 100 homes spread through 4 kilometres of cable is economically viable with a 1 dish system offering 10 quality satellite channels plus local terrestrial signals. At 250 homes in 8 kilometres of cable, a community is feasible with a 2 dish

system offering between 15 and 22 channels of programming. With 1,000 potential homes in 30 kilometres of cable, a system can equip itself with 3 to 5 satellite dishes and offer 30+ channels of programming.

At these numbers, a system must achieve approximately 17% home penetration at the end of 12 months to pay its programming, operating, and debt costs. The same system at 30% home penetration (3 out of every 10 homes subscribe) will typically retire its initial capital costs in between 40 and 55 months. The greater the home penetration (i.e., take up of cable services), the quicker the debt is serviced (paid off) and the sooner the system has "excess cash flow" (earnings beyond operational costs and debt retirement) to take out as operating profits or to reinvest in additional cable properties.

Smaller communities (down to the 100 home potential level) are viable even if they already have quality terrestrial reception. In locations where the terrestrial reception is degraded by terrain or other factors, the cable firm by providing quality terrestrial service in addition to the satellite programme offerings increases its initial (first year) penetration and this results in more earnings in a shorter period of time.

TERÇA	
11:25	Prayer da Alegria
13:00	Segunda Parte
13:30	Jamal da Tarde
14:05	Naz Paz dos Anjos
16:10	Memórias da TV
	Notícias das Açores

AMONGST THE NEW CABLE OFFERINGS - NBC Asia is 24 hour, PAS-2 fed, "family channel" with sports on weekends, soaps, movies, popular USA "Today," "Tonight with Jay Leno" and much more; 'The First Network for the New Asia'. RTP (Radio Television Portugal) is analogue, full transponder, on As2; 24 hours per day, heavy on soccer (futbol), drama, news, documentaries and music.

THE EUROPEAN (Programming) BOUQUET

It works this way. Germany's International broadcaster, Deutsche Welle, has an annual budget in excess of 600,000,000 DM to support both radio and TV. Prior to As2, they reached approximately 50% of the global surface and population with satellite delivery of TV programming as well as radio service feeds. With As2, they approach 97% of the world's population. By leasing a full 36 MHz transponder on AS2, and using DVB Complaint MPEG (digital), they require approximately 17% of the transponder. Their contract with As2 allows them to sublet the remainder they do not require but STAR TV has a condition in the STAR-AsiaSat contract that makes it impossible for any other pay-TV-broadcaster to use As2 except under very unusual conditions (and with STAR TV permission). This means DW could not find users for the remaining 83% of their transponder who are pay TV operators. DW hit upon the concept of convincing other state-run, government sponsored or free-to-air broadcasters to share their As2 transponder. Italy's RAI, Spain's RTVE, French TV5 (a service originally created to serve French speaking residents of Canada) fit the criteria. Together these four (plus a fifth to be announced) make up the "European Bouquet"; six programmers when you bonus Portugal's RTP analogue service also on As2. With the four DW-partner programmers will be more than 20 digital audio service channels, including Radio Canada International, several European international broadcasters, several German (and other) stereo music and talk format networks. And the data: Add a small adapter box between your satellite receiver and PC and instantly a data stream loads your PC with a steady flow of text and graphics.

*Six European 24 hour TV services, 20 radio services, a data network. **It is all free.***

Any DVB Compliant digital receiver can decode this for you and deliver to your cable, SMATV (or DTH) system every one of these services; one at a time or all together (for cable carriage).

There is more. Recall seeing the "interstice" blurbs on CNN that urge people to visit certain hotels or motels in a country because these facilities carry CNN? Well, DW is offering the same deal. If you operate a cable system and you have motels connected, your motels can have free advertising world-wide on the DW service just for the cost of preparing a colour photo of their place of business. A Coopers Beach motel (the Beach Lodge) will be amongst the first from the Pacific; a cable customer of Far North Cable TV. Details including cable TV, SMATV contracts from Johannes Firsbach at Deutsche Welle, fax 49-221-389-2784.



TELSAT COMMUNICATIONS LTD.™

SATELLITE TELEVISION CONSULTANTS, IMPORTERS AND EXPORTERS

**SELWYN, TERRI, JASON,
PETER, WAYNE & JANINE**

would like to thank those of you who attended the show and say what a pleasure it was meeting you. Those of you who didn't make it we hope to see you at the next premier TVRO Show.

In the meantime don't forget for all of your TVRO hardware & subscription programming requirements contact **TELSAT** for quality, service *and the experience that counts.*

17 Westhaven Grove, P.O. Box 1537, Palmerston North, New Zealand
Tel: (06) 356-2749 Fax (06) 355-2141 Int'l +(64) 6-355-2141 Cellular (021) 454-945

RELY ON PROMAX!

YOUR leading performer in the TV and AUDIO business.

PROMAX Signal Strength Meters for:

- FM ■ UHF ■ VHF
- SATELLITE ■ CABLE TV

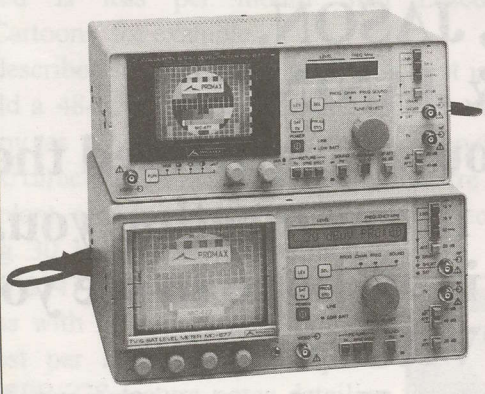
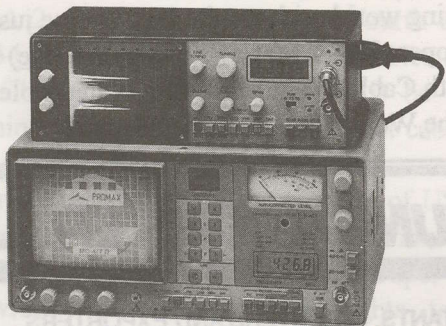

Gough Technology supply leading brands in their respective fields. With ISO 9002 certification, our customer sales and support service is guaranteed to meet your highest expectations.

PROMAX top quality test and measurement equipment:

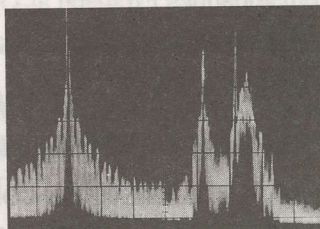

- SPECTRUM ANALYSERS
- MILLIVOLT METERS
- DISTORTION METERS
- AUDIO TESTERS
- PATTERN GENERATORS
- LOW DISTORTION LF GENERATORS

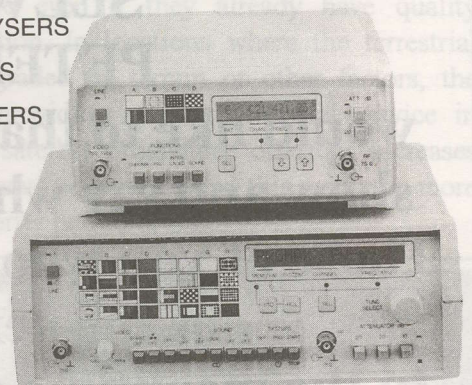

Freephone 0800-80-20-20

Freefax 0800-68-20-20

Email: sales@goughs.co.nz

TELARC
REGISTERED
SUPPLIER

CHRISTCHURCH
245 St Asaph Street
Christchurch, New Zealand
PO Box 22073
Fax 0-3-379 6776. Tel 0-3-379 8740

AUCKLAND
349 Great North Road
Auckland, New Zealand
PO Box 68150
Fax 0-9-378 4592, Tel 0-9-376 3174

WELLINGTON
1 Jackson Street, Petone
Wellington, New Zealand
PO Box 38421
Fax 0-4-568 4376, Tel 0-4-568 6675

GOUGH
TECHNOLOGY

Precisely!

McAra

WITH THE OBSERVERS

PRESS-DEADLINE UPDATE

Palapa C1 testing at 113E will be identifiable in non B2P reception areas by the P3-5 level carriers present possibly in IF region of 990 Hz, 1100 Hz, 1390 Hz and 1370 - 1410 Vt. Inside of B2P coverage areas look for signals that are significantly stronger than B2P. From initial testing to B2P > C1 "hand-over" could occur very rapidly.

Palapa C1's successful launch on the 1st of February and its reported location 'on-station' five days later headlines this month's report. Testing of the new high power C-band beam into the (south) Pacific from 113E should have begun between our deadline and receipt of your copy of SF (the February 23rd edition of *Coop's Technology Digest* should have the first observer reports).

AsiaSat 2 regular service (as opposed to testing) began January 28th at 0900UTC with the sign-on of the RTP (Portugal) on vertical transponder 9A (IF 1173). Reports from across the Pacific indicate this transponder is not operating at expected levels (P3 to P4 on 3.7m dishes from New Caledonia to southern New Zealand; P5 on 3m dishes in south-eastern Australia). RTP's contract with an Australian commercial system installer had specified dishes 2.4m and smaller, they are now being upgraded to 3m based upon a real footprint level in the 31dBw region there.

If transponder 9A is operating below anticipated levels, 4B (horizontal, 1385IF) presently carrying STAR Mandarin service in Newscrypt is above anticipated levels. "This is the strongest satellite signal I have ever seen on any satellite across my full arc; from 185E to 68E" reports **Anthony Williams** in Geelong, Victoria. "This signal is stronger than RAJ here, previously my best signal level" adds **Steffen Holzt** in New Caledonia.

Why might some transponders be strong and others weak? The possibilities:

1) The transponder power output is run in a back-off state (i.e., below maximum output). This is routinely done with transponders that carry multiple signals, or when the satellite operator has reason to believe a particular transponder is ageing too fast. RTP believes they are "saturating" (running at full power) transponder 9A.

2) There are two or more different transmit antenna patterns for the satellite. PanAmSat, for example, has a Pacific Rim and an Oceania beam on PAS-2. AsiaSat publicity insists all of their downlinks share a common beam (see SF#18, p. 22) which means signal variations would not be due to 9A being on one beam while 4B is on a second beam.

However, a well-connected source in Australia insists that contrary to AsiaSat public statements, there are two distinct transmit beams on AS2; a "Pacific Beam" and an "Asian Beam." This source reports the Asian beam would produce



STAR TV UPLINK (CauseWay Bay-CWB) as it first turned on January 15 to test analogue uplink via AsiaSat 2. Photo from 2.1m dish at SatFACTS (NZ) with look angle near 5 degrees.

signals that are 5 dB down from the Pacific Beam levels in Sydney, as much as 12 dB down in New Zealand. If this is accurate information, transponders fired through such an Asian beam would be unusable east of Australia and marginal in many Australian areas. However, this same source reports RTP's 9A is on the Pacific beam so that does not account for the down-levels of RTP.

3) A transponder is not functioning properly. Transponders break, some are even defective at turn-on. There are significant legal problems here for a satellite operator; if they know a transponder is defective, fail to inform the user of the defects, and still collect full transponder rental for a defective transponder, the programmer using the satellite is in a difficult position. He can 'demand' to be moved to a new transponder (a "spare") if he can prove his case, demand a reduction in monthly rental fees, or seek a new transponder on another satellite.

A satellite operator who fails to "come clean" with a programmer concerning a defective transponder risks losing credibility with other customers as well; programmers do talk with one another.

WITH THE OBSERVERS: Reports of new programmers, changes in established programming sources are encouraged from readers throughout the Pacific and Asian regions. Information shared here is an important tool in our growing comprehension of the great variety of programming services now on offer from regional satellites. Photos of yourself, your antenna system, and off-screen photos are welcomed. Off screen photos are not difficult to shoot: For PAL or SECAM, set camera to f3.5-f5 and 1/15th second with ASA100 film; for NTSC, 1/30th second. Hold camera steady (no flash!) or mount on tripod and focus from approximately 1.5 metre distance. Alternately, submit VHS format tape (any standard, speed) to SatFACTS and we will photograph your reception. Deadline for March 15th issue: March 4 by mail or fax to 64-9-406-1083. See reporting form, page 30, this issue.

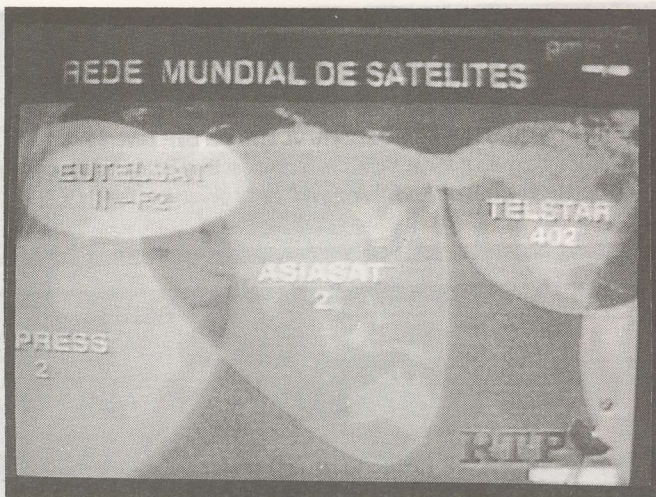

SIGN-ON transmission of Portugal's RTP (0900 UTC January 28) included detailed description of various world-circling satellites now in use; AS2 completed coverage of all but south-eastern Pacific. (photo from 4.5m at SatFACTS, NZ)

These remain early days for AS2; certainly the first test signals in mid-December were on average far stronger than those now being observed. And, some of the unmodulated test carriers seen for short periods on yet unclaimed transponders are far stronger than those in use by either RTP or Star TV's Newsrypt Mandarin service. See Orbit Watch for a full synopsis to press deadline time.

Bruce Barnett (Wanaka, South Island, NZ) reports RTP is "clean" on a 3.7m there at a look angle near 7 degrees when his Echostar 5300 threshold extension receiver is cranked into TE position 8; the level being nearly identical to NHK from PAS-2.

Alec Zapara reports P4-5 level signals from the STAR Mandarin and the special SPACE test card signal from his location in western Australia on a 1.8m dish equipped for circular polarisation (i.e., there is another 3dB there when he switches out to a linear feed). Per our report on the Russian Gz25 (103E) "bleeding" into AS2 (SF#18, p.25), Alec notes, "The Russian service from 96.5E wanders through the AS2 signals (1475IF) typically at some time between 10PM and 10AM local time here." Yes, our January report should have noted that AS2 is in a "box" between two wandering Russian birds (103 and 96.5). A dish larger than Alec's 1.8m would likely not see the 96.5 service because of a tighter beamwidth that would null the Russian signal(s). A similar report, undoubtedly from the 103 Russian, comes from Anthony

The "P-Code" Reporting System

Observers are encouraged to adopt the "Universal Reporting System" as refined by Steffen Holzt in New Caledonia (SF#11, p. 24).

- P5 - Noise-free on 27 MHz (full) bandwidth receiver
- P4 - With bandwidth reduced below 27 MHz, no sparklies or tearing
- P3 - With bandwidth reduced, some sparklies present but no tearing
- P2 - With bandwidth reduced, picture is watchable with sparklies and tearing (jitters on image edges)
- P1 - Must be an enthusiast to watch!

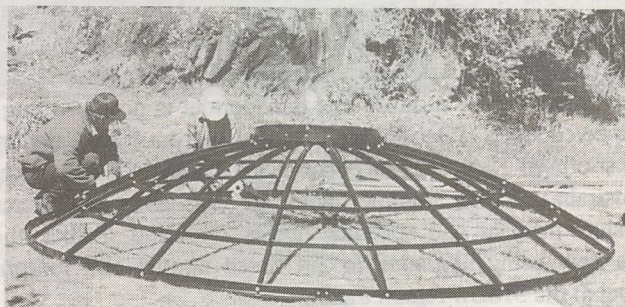
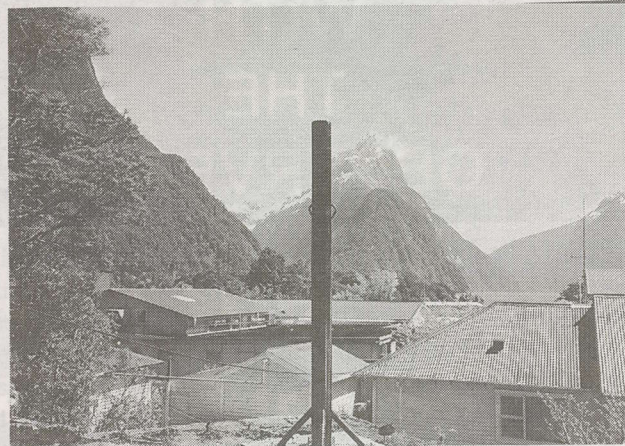

ASSEMBLING 3.7M KTI in mountainous terrain in South Island (NZ), Bruce Barnett is pleased to report quality RTP reception from AS2 at look angle near 7 degrees (dish mounted on pole in front, top photo). You missed an exciting show, Bruce.

Williams in Victoria who finds Indian language programming on an IF in the 1280 range chopping into his AS2 reception at times (on a 3m KTI dish).

Zapara updates on Intelsat at 66E observing "Over the past year there has been a 3dB improvement in signals on C-band from this satellite; RFO/CFI is now P4 while WorldNet is P3." He also is seeking some assistance: "Does anyone have the correct instructions for setting the declination for a Skymount horizon to horizon mount by Skyjack?" Details to SF for forwarding to Alec.

Galaxy update. A "properly configured" PACE DGT-400 receiver can receive up to 21 Galaxy channels on Optus B3 including the pub/hotel Prime Sports, BBC World Service, Tele Italia, and World Movies. However, until July 1997, regulations prohibit Galaxy delivering more than 10 programme channels to individual homes so Galaxy will be offering different combinations of services (never totalling beyond 10 per decoder box) and subscribers will select the package that best suits their viewing needs. With more channels technically possible than "on offer" this creates the almost perfect environment to give incentive to SmartCard authorisation scheming within the Australian market. If the Australian authorities had set out deliberately to foster Smart Card Piracy, they could not have created an environment more attractive to the piracy card world. European and Canadian card cloners and card manipulators are probably already setting up shop in Australia!

No public statement yet concerning reconfiguration of the Galaxy Optus service for New Zealand; however, we understand the Prime Sports feed for commercial businesses could be "cleared" for NZ distribution shortly.

SatFACTS PACIFIC OCEAN REGION ORBIT WATCH: 15 February 1996

Copyright 1996: SatFACTS, PO Box 330, Mangonui, Far North, New Zealand (Fax: 64-9-406-1083)

AsiaSat 2 / Now Testing 100.5E

Pole	IF Freq
Hz	1,510
Vt	1,490
Hz	1,470
Vt	1,450
Hz	1,430
Vt	1,410
Hz	1,380
Vt	1,370
Hz	1,350
Vt	1,330
Hz	1,310
Vt	1,290
Hz	1,270
Vt	1,250
Hz	1,230
Vt	1,210
Hz	1,190
Vt	1,170
Hz	1,150
Vt	1,130
Hz	1,070
Vt	1,090
Hz	990
Vt	1,010

Service
No reports
Strong test carrier
Narrowband noted
Test carrier
No reports
Star MPEG Tests
Star Newscrypt
Test carriers
Narrowband carriers
Test carriers
No reports
Narrowband carriers
AS2 test card
AS2 test card
Reuters (data)
No reports
Data carriers
RTP Portugal FTA
AS2 test card/ (DW)
No reports
Strong test carrier
No reports
No reports
No reports

PanAmSat PAS2 / 169E

Pole	IF Freq
Hz	1,426
Vt	1,406
Hz	1,372
Vt	1,346
Hz	1,300
Vt	1,288
Hz	1,249
Vt	1,218
Hz	1,183
Vt	1,161
Hz	1,115
Vt	1,110
Hz	1,060
Vt	1,038
Hz	998
Vt	985

Service
<u>ABN/CCTV/CTN/NBC</u>
<u>CMT</u>
Discovery/B-Mac Pal
MTV/B-Mac-FTA-N
Occ. Video Feeds
ESPN/B-Mac-NTSC
Asia Feeds/Occasional
TNT/Cartoons-BMac-N
CNN (X2)/FTA NTSC
Prime/TMZ/Feeds
NHK/FTA NTSC
Occ. Data feeds
Filipino/GI MPEG
ANBC/FTA Pal
Data
Bloomberg/MPEG

February 1996 NOTES

B-MAC is analogue encryption system used by Discovery, ESPN et al. **FTA** is "free to air" (**bold face**). **MPEG** is digital (also "dig."). Underlined is subscription available. NTSC is US TV video standard, Pal is European/Pacific standard. All Intelsat not noted are right hand circular while all Gorizont are left hand circular. Readers north of the equator have far greater selection than shown here.

Intelsat 174/177/180E

Intelsat	IF Freq	Service
180E	1,432	K'stone
180E	1,388	MPEG
180E	1,325	MPEG
180E	1,310	MPEG
180E	1,277	NBC/e
180E	1,256	K'stone
180E	1,223	CBS/e
180E	1,179	W'Net
180E	1,105	RFO
180E	1092/a	Data
180E	1,054	Data
180E	1050/a	Canal +
180E	1,021	9 Aust.
180E	1018/a	Feeds
180E	984	NZ Dig.
177E	984	Feeds
174E	984	Feeds
180E	980	NZ Dig.
180E	972	NZ Dig.
180E	964	NZ Dig.
177E	963	Feeds
174E	963	Feeds

a/ left hand circular (all others RHC)

Gorizont Satellites (Gz25/103, Gz41/130, Gz18/140 Gz42/142.5, Gz21/145E)

IF Freq	103E +/-2.1 deg.	130E +/- 0.7 deg	140E +/-4.2 deg.	142.5E +/-0.1 deg.	145E +/- 3.5 deg
1,475	Moscow 1	Raj (X2)	Moscow 1	ATN (X2)	Moscow 1
1,425	Muslim	SunMovie	Muslim	JJAY	
1,375	APNA	TestVideo		vacant	
1,325		AsiaNet		EagleNet	
1,265		TestVideo		EMTV	Moscow 2
1,225		SunMusic		Udaya	

Selected Ku Band Signal Targets

Sat	IF / RF	Pol	Service
B1	977	Vt	Data, radio, TAB
B1	1,193	Vt	Occ. Video
B1	1,219	Vt	Occ. Video
PAS2	1,037	Hz	Test Card,feeds
PAS2	1,395	Vt	Occ. Video
PAS2	1,432	Vt	Occ. Video
I177w	11,015	Vt	NBC feeds

Credits to Robin Colquhoun, Shane Wilson, Anthony Williams, Steffen Holzt, Kevin Green, Colin Wenzel, Mark Long and others. Inclination numbers for Russian Gorizonts reflects inclined orbit drift within typically 24 hour period indicating birds may not be over equator at most times.

RECENTLY
RELEASED

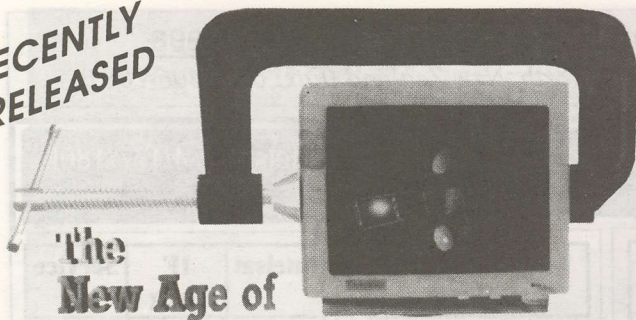

The
New Age of
**Digital Video
Compression**

SHELburne FILMS/MLF Satellite Series Videotapes

EDUCATE YOUR STAFF WITH TWO SATELLITE TECHNOLOGY VIDEOTAPES — PERFECT FOR CORPORATE TRAINING AND THE CLASSROOM

"THE NEW AGE OF DIGITAL VIDEO COMPRESSION" is an information-packed, quality production videotape which offers an in-depth, on-location tour of one of this century's most exciting and revolutionary technological developments:

Featuring interviews with satellite and compression industry leaders: Stanley Hubbard II - USSB; Thomas Bracken, DirecTv; Lisa Hobbs, Scientific-Atlanta; Mark Brady, TV/COMM; Chris Kelkar, General Instrument; Todd Townsend, CLI; and Michael Antonovich, PanAmSat.

Demonstrations of compression applications: educational satellite delivery; desktop and corporate videoconferencing; twisted pair telephone delivery; direct-to-home satellite delivery; personal computer & CD-ROM; as well as laboratory demonstrations of MPEG-2 digital video at various data compression rates.

A Technical Short Course Covering: MPEG-1 & MPEG-2; pre-processing; motion compensation; Discrete Cosign Transform; quantization; Huffman coding; I, P, and B frames; Open Systems Interconnection Model; satellite transmission formats and compatibility issues.

"The video presents the information in a very smooth, progressive and precise format. In fact, we would like to utilize the video for training purposes." — David Gordon, Field Service Engineer, TV/COM International.

A frame from *The New Age of Digital Video Compression* that shows typical uses for various MPEG-2 encoding data rates.

DATA RATES MPEG-2	
PPV Movies	1.152 Mb/s
News/Entertainment	3.456 Mb/s
Live Sports Event	4.608 Mb/s
Studio Quality TV	8.064 Mb/s
16:9 Wide Screen TV	5.760 Mb/s
High Definition TV	14.000 Mb/s

THE
ERA
OF

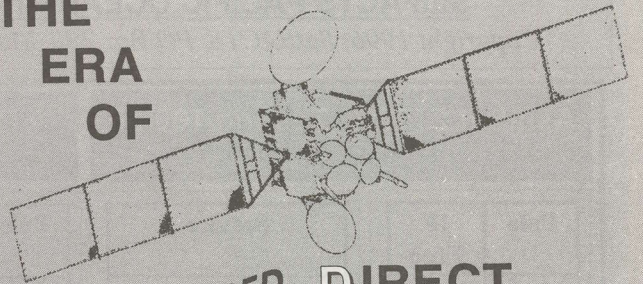

NEWLY REVISED
& UPDATED

**DIRECT
BROADCAST
SATELLITES**

The Era of Direct Broadcast Satellites presents the basic technical concepts concerning how the new DBS satellites in orbit and TV receiving systems operate.

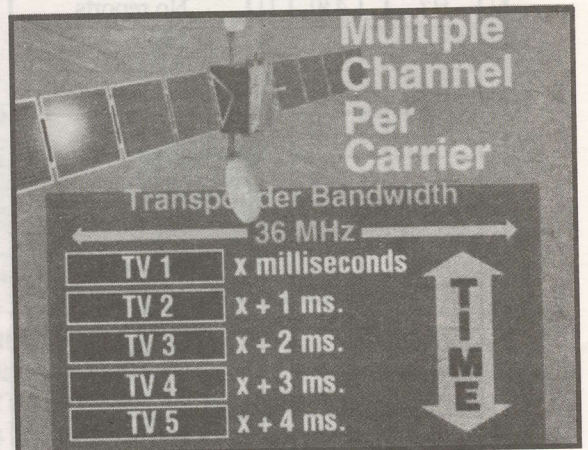

"THE ERA OF DIRECT BROADCAST SATELLITES" makes a detailed examination of the high-powered satellite technology which already has become a major force in the U.S.A. and around the world. Designed and programmed to reach the home viewer directly, DBS satellites are using new digital video compression technologies to bring about a worldwide entertainment revolution.

DBS systems in the USA (*DirecTv, USSB, Primestar, & EchoStar*), Europe, Asia and Australia are examined in depth, including how the technology works and the economics of their operation. Mark Long visits with leading experts involved in both the development and marketing of these new DBS services. He also takes the viewer on a journey through the history of home satellite TV, meeting some of the earliest pioneers and key players in the development of the new television technology. (59 minutes in length.)

Order either videotape for: \$ 149.95 VHS - NTSC format or \$ 189.95 VHS - PAL format PLUS \$7.50 (N. America) or \$ 17.50 (Overseas) shipping & handling. Or order both tapes NOW for \$ 299.90 (NTSC) or \$ 379.90 (PAL) & we'll pay the shipping charges.

Available from **MARK LONG ENTERPRISES, INC.**
P.O. Box 159, Winter Beach, FL 32971
US Fax: 1-407-589-9411 Thailand Fax: (66) 53-818-435

DON'T MISS MARCH SatFACTS! Subscribe Using This Form.

AsiaSat 2 is operating; Palapa C1 will be testing soon; Palapa C2M is due up in April. And that is only the beginning of the greatest year in Pacific satellite expansion to date! Stay up with the changes through an airmail subscription to SatFACTS Monthly.

- ENTER my 12 MONTH Subscription to SatFACTS starting with March 15th issue
 ENTER my 36 MONTH Subscription to SatFACTS starting with March 15th issue

NAME _____

Company (as applicable) _____

Mailing address _____

Town/City _____ Country _____

Amount to send: 1 year - NZ\$40/A\$61/US\$40 (outside NZ, Australia) or 3 years - NZ\$100/ A\$150/US\$100
if by cheque; **VISA?** See below. Return to: SatFACTS Monthly, PO Box 330, Mangonui, Far North,
New Zealand (Fax for VISA orders only: 64-9-406-1083; include VISA form immediately below)

USE THIS FORM ONLY WHEN CHARGING ORDER ON VISA CARD

Please charge my VISA card as follows:

- One year of SatFACTS Monthly (NZ\$40/A\$61/US\$40)
 Three years of SatFACTS Monthly (NZ\$100/A\$150/US\$100)
 SATELLITE TELEVISION: The Booklet (NZ\$10/A\$12/US\$10)
 One year of COOP'S TECHNOLOGY DIGEST (NZ\$125/A\$125/US\$125)

Name (as it appears on VISA card) _____

VISA Card Number: _____ - _____ - _____ - _____

VISA card expiration date: _____

Instructions: If ordering by mail, return this complete (3-part) card (SatFACTS, PO Box 330, Mangonui, Far North, New Zealand); if ordering by FAX, send full card as single sheet to 64-9-406-1083.

SUPPLEMENTAL MATERIALS from SatFACTS MONTHLY: ORDER FORM

- SATELLITE TELEVISION: The Booklet.** Excellent home dish ownership presentation piece, written for the layman with contributions from world famous science writer *Arthur C. Clarke*. This 28 page (four colour cover) booklet from SPACE Pacific will help you explain how owning a dish creates a link to the world. Price: NZ\$10/A\$12/US\$10 via fast post.
- COOP'S TECHNOLOGY DIGEST.** For the really serious enthusiast, investor, business person in satellite TV and allied industries. Ten issues per year, jam-packed with information you will not find anywhere else. "Coop" routinely culls more than 60 monthly publications, \$1,500 per year newsletters, Internet and his hundreds of private contacts to keep you up to date on the REAL changes underway in communications. Must reading for everyone who needs to know first and accurately the changes that are sweeping the communications world; now in its 4th year. Ten issues per year, fast post world-wide. **SPECIAL OFFER:** Normally NZ/A/US\$250 per year: Until March 15th special 1/2 price offer of merely NZ\$125/A\$125/US\$125. Save fifty percent and start with the very next (March 1996) issue!

OBSERVER REPORTING FORM - Due March 04, 1996

NOTE: Use MIDDLE card (below) to report on Palapa C1!

- New programming sources seen since 15 January: _____

- Changes in pre-existing programming sources since 15 January: _____

- Other: _____

Note: Please include transponder number/receiver IF reading for each programmer and use P1-5 code.

Your Name _____

Town/City _____

Make/size dish _____ LNB _____ Receiver _____

Mail: SatFACTS, PO Box 330, Mangonui, Far North, New Zealand / Fax 64-9-406-1083

SPECIAL PALAPA C1 REPORTING FORM

- Palapa C1 test signals first seen here at _____ (UTC), _____ (date) on transponder(s) / IFs of _____

- Subsequent Palapa C1 signals seen here include: _____

- I compare the BEST Palapa C1 signal(s) [identify which _____] as being on a quality level with PAS-2 programmer _____

- I compare the WORST Palapa C1 signal(s) [identify which _____] as being on a quality level with _____ programmer _____

Observer Name _____ Location _____

Antenna Size _____ LNB _____ Feed Type _____ Receiver _____

Mail: SatFACTS Monthly, PO Box 330, Mangonui, Far North, New Zealand / Fax 64-9-406-1083

BECOME A MEMBER OF SPACE. Complete this form for no obligation "*Invitation to Join*"

SEND TO ME with no obligation explanatory brochure sheets detailing how I might become a member of **SPACE Pacific**.

Your Name _____

Company (if applicable) _____

Mailing Address _____

Town/City _____ (Country) _____

Return to: **SPACE Pacific**, PO Box 30, Mangonui, Far North
New Zealand (or, fax to 64-9-406-1083)

ORBITRON

Complete Satellite Antenna Systems World Wide

*PRECISION
PERFECTION
DURABILITY
DEPENDABILITY
SERVICE
SELECTION
EXCEPTIONAL
EXPERIENCE
INNOVATIVE
NUMBER ONE
AMERICAN MADE*

NEED WE SAY MORE.

ORBITRON
351 S. Peterson St.
Spring Green, Wisconsin U.S.A.
53588
Tel (608) 588-2923
Fax (608) 588-2257



IN NEW ZEALAND: Telsat Communications Ltd., PO Box 1537, Palmerston North
Tel: 64-6-356-2749 • Fax: 64-6-355-2141

When they wanted Cable Television throughout Europe, Asia and America they called the man from Maser.



James Golden

James Golden has a world of experience, spanning twenty years, in Cable Television.

He has advised in every aspect of developing, establishing, operating and managing Cable Television on three continents.

Maser is now making that extraordinary skill and knowledge available to Cable Television operators in New Zealand.

There is more. Maser has formed alliances with General Instrument, Belden, CableData, Gilbert Engineering, Channelmatic, C & E Corp, Loma Scientific and Alpha Technologies. Each and every one an unquestioned market leader.

From studio to set top. Everything you require including automatic systems for inserting commercials and foolproof billing. All from the world's leading suppliers.

And, of course, there is Jim.

Call Maser now on 64 9 479 7889 or fax 64 9 479 6536 and we'll put you together with the best names in the business.

P.O BOX 65-166 Mairangi Bay, Auckland, New Zealand

MASER
MASER TECHNOLOGY GROUP

