

**COOP'S
SATELLITE
DIGEST**

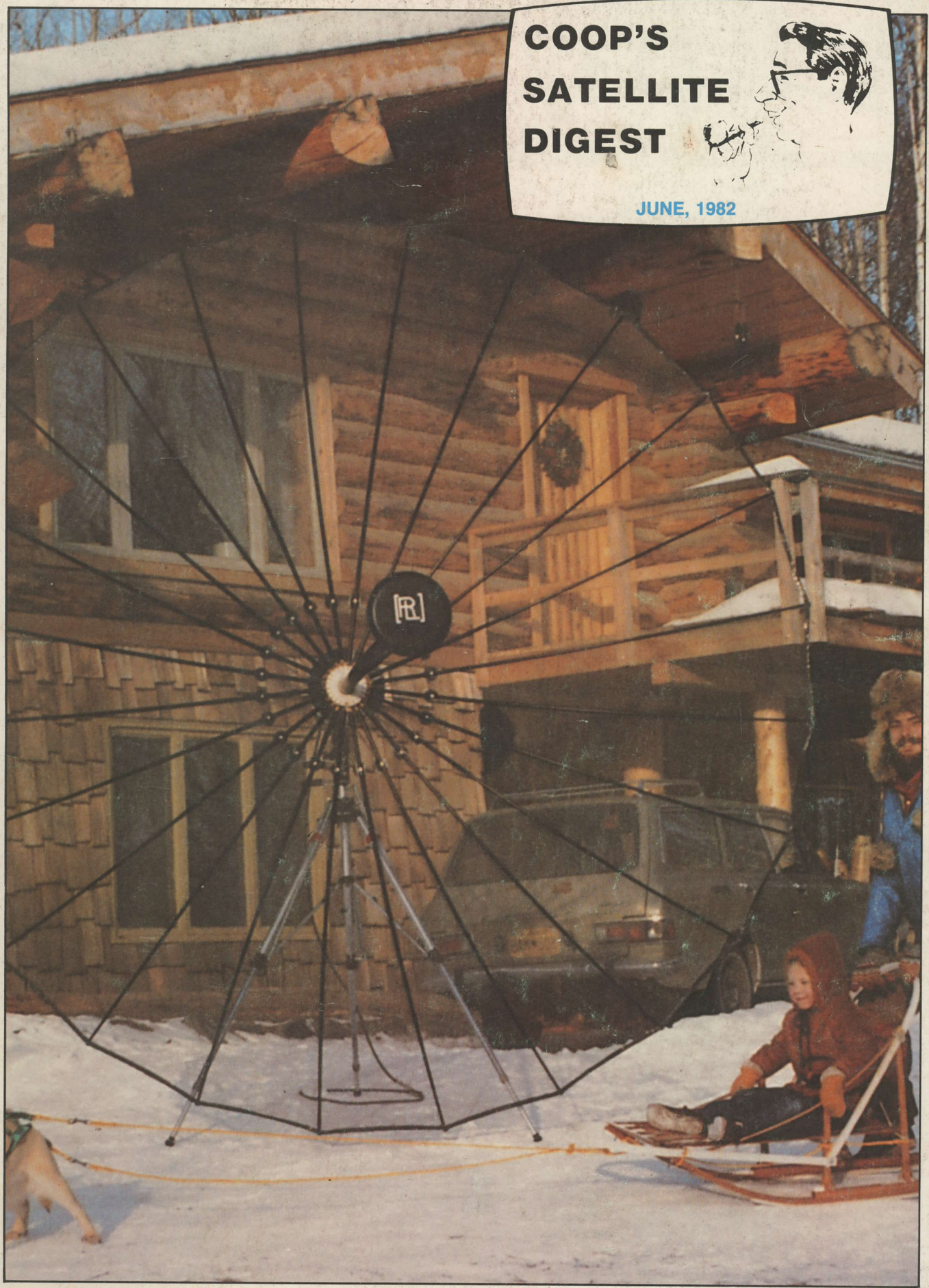

JUNE, 1982



We'll pay to find out.

If your company buys or sells satellite receiving equipment and it's not Apollo™, we'd like to know the reason why.

National Microtech supplies more satellite TV antenna systems than anyone in the world—we've got to have some **good** reasons why! In fact, you're looking at some of the world's best satellite TV equipment on this page.

Our new Apollo Z-1 and our Amplica R-10 both use an LNC instead of the old-fashioned LNA—and both tuners interface to change the polarity electronically (no rotor) and aim the antenna remotely.

The Microdesign receiver has a wireless remote control with memory for channel, polarity, and antenna aiming interface.

The new Apollo X-10 antenna is made of **precision** injected fiberglass panels that are guaranteed to match perfectly. The performance of the Apollo X-10 at 4 and 12 GHz is the best of the 3 meter dishes we've seen in the industry.

Our equipment makes good sense, and our prices are world class. We'll gladly pay for your call to find out the reasons why you're not using National Microtech's equipment...and we'll promise you some good reasons why you should. Call today **TOLL FREE**.



**National
Microtech, Inc.**

P.O. Drawer E/Grenada, MS 38901
In Mississippi 601-226-8432

Toll Free: 800-647-6144

While most major sporting events and movies can be received on Apollo systems, National Microtech cannot sell or transfer the viewing rights.



Apollo X-10

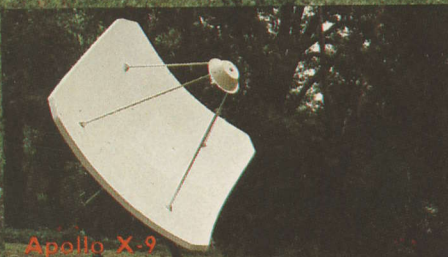

Apollo X-9



Amplica R-10 Tuner

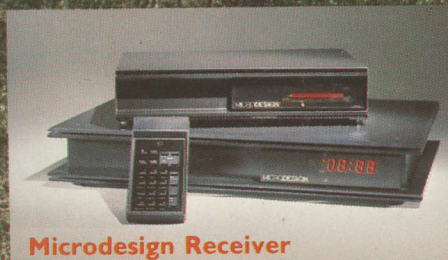

Microdesign Receiver



Apollo Z-1 Tuner

TOP OF THE MONTH

W4 has settled in but the use 'pattern' for W3 will undoubtedly not shape up until W5 (to be launched this month) is on station, operating, and, the final musical transponder game is over at Western Union. The Falkland Islands 'crisis' has provided a great deal of unusual video during the past month, most of it in the early morning period over on W3. There may be a 'pattern' here; when big news breaks, swing the dish to W3 and prowl transponders 1, 3, 9, 15, 17 and 19 looking for the US end of world wide satellite feeds heading for New York.

The saga of F4 continues; this bird may prove to be the RCA albatross. 'Insider' newsletters circulated to the satellite industry are increasingly warning of a transponder 'surplus' by 1983, and suggest big price cuts ahead for transponder time. It does not appear to be a shortage of services that is keeping F4 vacant, but rather a shift from RCA to Western Union of many customers.

The **WEATHER CHANNEL** cranked up on F3R TR21 early in May; a very disappointing service with poor video, inept on-air personalities and production values far below most professional cable services. Cable systems are not dumb; they'll let the folks at the Weather Channel know how poor the service 'looks' and sounds in short order. We expected far better things from John Coleman!

RCA, meanwhile, cranks up its cultural channel service on F4 (probably TR8) this month; and the **HEALTH CHANNEL** will be operational (F3R, TR17) the first of July.

JUNE 1982

COOP'S COMMENT page 2
 FCC COVERAGE MAPS / F3R, F4 and W4 page 4
 MOISTURE — Keeping It Out Of The System page 18

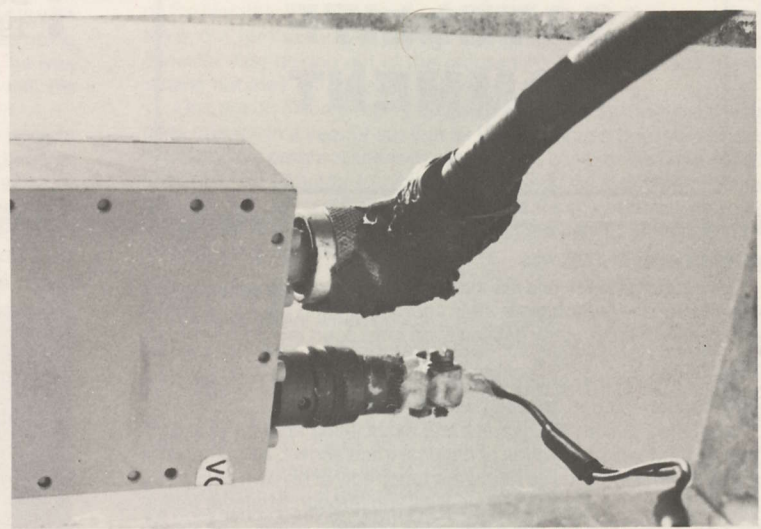

NON-DOMSAT UPDATE (S.J. Birkill) page 30

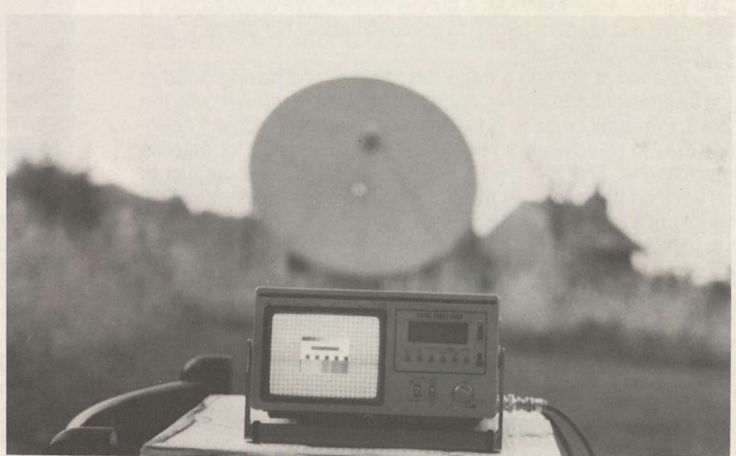

AUDIO RECOVERY — SCPC Basics page 38
 DAVID'S TVRO NOTES (David Barker) page 54
 BIRD OPERATIONAL NOTES page 60

COOP'S SATELLITE DIGEST

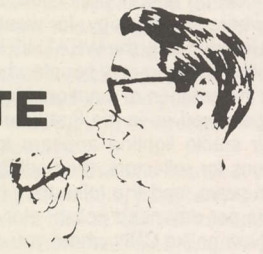

COOP'S SATELLITE DIGEST published monthly by West Indies Video, Ltd; a Turks & Caicos Corporation with corporate offices located at Grace Bay Providenciales, Turks & Caicos Islands (West Indies). U.S. offices are maintained at Ft. Lauderdale, Florida. All mail including subscriptions, advertising inquiries, reports and letters should be addressed to CSD, P.O. Box 100858, Ft. Lauderdale, FL 33310. CSD office hours in Ft. Lauderdale are Monday - Friday 9:00 AM to 4:00 PM. Telephone (305) 771-0505. CSD is mailed worldwide on or before the 1st of each month, first-class (airmail). Annual subscription rates are \$50 (US funds) for USA, Canada, Mexico; \$75 (US funds) elsewhere. Entire contents copyright 1982 by West Indies Video, Ltd; Robert B., Susan T., Kevin P., and Tasha A. Cooper.

COOP'S SATELLITE COMMENT

- Bottom Of Programming Barrel?
- 1983/Year of DBS?

JOHN ROHNER AND EIA

I have watched with mild dis-interest while John Rohner has gotten himself into one legal hassle after another, ending (or so I thought) with his filing a bankruptcy petition in an Iowa court this past February (see **CSD** for April 1982).

The latest Rohner antic suggests the true genius of this man. You might be interested in knowing what he's done now.

John tried to start a national trade association about a year ago. Then he tried to start a series of national trade shows. All of the while he was advertising satellite hardware reportedly of his own design, for sale, via his own irregularly issued flier, and through whatever magazines as would take his advertisements on credit terms. The magazines that had him on their books, when he filed bankruptcy papers this past winter, apparently lost a bundle on him. We stopped taking his ads when our readers began to complain about his delivery, and order fulfillment, practices.

Having failed at starting a trade association, and having failed at staging a series of trade shows, John has decided to throw in with the 'big' boys. His latest crusade is to urge the Electronics Industry Association (EIA) to re-activate a largely in-limbo sub-group for satellite communications. The EIA held a meeting of this sub-group, just to keep it alive on the books, at the end of March, in Washington, DC. John sent out a few thousand notices to the industry suppliers urging them to join him there. From the private terminal industry, nobody but Earth Terminal's Bill Gable showed up, and he attended to represent SPACE, along with SPACE counsel Rick Brown.

John was in the company of some pretty big people. Such as S/A leader Sid Topol, equally big wheels from RCA (consumer electronics group) and others who look at private terminals just a tad differently than you and I. John came with a message. He presented himself as an innovator of low cost TVRO equipment, claimed to be a 'pioneer' in this industry (by the Ted Turner 'arrow-definition,' John qualifies!), and an industry leader and spokesperson. The S/A, RCA et al people sitting around the meeting room probably averaged annual salaries in the \$150,000 range, and they can be pardoned if they never heard of John Rohner.

John spoke well, and to the majority of the listening ears he made sense. He urged the group to establish two sets of hard standards for the home TVRO industry. He belittled people who build home industry antennas, characterizing them as people who run about the countryside in the dark of night pulling converted boat trailers loaded with 'junk antennas.' After warming up on antennas, and the sorry state he claims exists in the antenna part of the industry, he then set about attacking people who design and manufacture home TVRO receivers. He wanted the EIA to adopt a set of 'tough standards' pertaining to receiver designs.

John came off, to this uninformed group, as a cross between Ralph Nader and Arthur C. Clarke. What he was asking them to do was to get active, and involved, in the **policing** of home TVRO manufacturing standards. And he volunteered to help teach them where our industry has gone astray, and to show them what needed to be done to clean up 'our' act. Those of us who remember the design and manufacturing quality of John's "BASIC" receiver (the one he discarded when he filed bankruptcy), the power transformers held in place with what appeared to be chewing gum, and the complaints of customers who

could neither get their BASIC receivers to work, or John to refund their money, have to smile just a little bit at the image of John Rohner leading a EIA campaign to set standards for an industry which EIA hardly knows exists.

Fortunately, the whole matter got shelved for now. You can be sure, however, that Rohner will not give up easily. To folks such as RCA, who will surely one day enter either the 4 or 12 GHz home terminal hardware market, John probably looks like a golden opportunity to "hire a gunslinger" from within the enemy camp.

The day will, yes must, come when we will have industry standards. But they will come from **within** this industry, not from some outside group that knows virtually nothing about our hardware and our systems. We'll eventually accept such standards, because we have matured to the point where we can accept our own faults, and take collective steps to right those faults. **This** is not the time, **nor** is the EIA the group to tell us what our standards should be. But most of all, John Rohner is certainly not the fellow to design our standards. Can you imagine where this industry would be today if our 'standard' receiver was Rohner's BASIC unit, and our 'standard' antenna was a Rohner chicken wire spherical!

Atta-boy, John. Keep up the good work of being our industry's self appointed ambassador to the world. What you are doing for our image, at groups such as the EIA, will insure that they leave us alone for another couple of years. Anyone who sees you as 'typical' of what our industry is, or does, will never take us seriously. And that ain't all bad!

BOTTOM OF THE BARREL?

Cable's amazing success with satellite programming delivery pushing the attack to wire all of metropolitan and suburban America may be reaching a plateau. Even the inventive cable programming folks could be running out of valid programming concepts.

A singular (and therefore not trend setting) case in point is the inauguration this past month of the WEATHER CHANNEL over on TR21 of F3R. Now I am a 'weather buff' and I appreciate a good weather forecast. Through the years I have developed some friendships with a number of television weather people and I admire the thin line they walk between 'show biz' and being professional meteorologists. I am also a student of the GOES weather satellite system, and the computer enhanced weather radar portraits which can now be telephone 'dialed up' virtually anywhere, from virtually anywhere. Technology, for weather folks, is wonderful.

Unfortunately the WEATHER CHANNEL seems to have been put together by a group of people whose most recent television challenge was the creation of a national television service for Uganda. Nothing they showed us in the first week or so even remotely looked good. Their studio lighting appears to have been created with old milk cartons for reflectors; their set is straight out of Missoula prime time local news, and the folks they have hired to staff the operation 24 hours per day need polish; alot of polish.

Now unlike CNN where you can tune in for a minute and spend a day, even given good production values and snappy personalities, only a relative handful of weather freaks are going to stay with the WEATHER CHANNEL very long; under the best of circumstances.

ABC's John Coleman (**Good Morning America**) is the bright person behind this service, which uplinks from Atlanta through the Southern Satellite Systems facility. You can find Coleman doing his ABC weather feed from either Atlanta or Chicago on transponder 5 or 19 most weekday mornings, for Good Morning America. There, armed with the kind of video gadgets that only ABC could afford, Coleman drifts into and out of maps, satellite photos and a can of V8 with magical motion. We felt certain that Coleman would bring some of those gadgets with him, since even a novice in the field would tell him that if he was going to grab and hold an audience for the WEATHER CHANNEL, he was going to have to look space-agy and ahead of the world with his weather information.

Instead, with see a single 'hard set' with a Holiday Inn podium (which I should point out, in case anyone but I cares, sits squarely in front of the part of the Caribbean I care about!), and inept weather informants stumbling over golf ball sized hail in Fargo or describing 'tremendous chains of thunderstorms in central Minnesota'; while the computer enhanced radar of the area barely shows a light rain.



I note that ABC has given Coleman their permission to allow him to engage in this double employment. If somebody doesn't jump in and give the WEATHER CHANNEL a new look and sound, in a hurry, Coleman will be back in Chicago, fulltime, shortly.

Chewing up a full and valuable transponder on F3R with this kind of service is hardly good use of the limited spectrum. Unfortunately, we may be headed down the same path with the new HEALTH CHANNEL due to jump off into space about the 1st of July. That's when WOR, now on F3R transponder 17, will be forced to move; first to a temporary transponder on W4 on July 1 and then to a permanent transponder on W5 as soon as W5 is operational (possibly mid-July). The W5 transponder, and the interim W4 transponder, are coming from Robert Wold. The W5 assignment is reported to be TR4 (vertical). There are those who would point out that by losing WOR off of F3R, that still leaves WGN (TR3) and WTBS (TR6) on 'the cable bird.' Some would also point out that two indies is plenty of choice and WOR will not be missed.

I'm not so sure that is the case. WOR does very little with hard news (other than a mid-day report which is well done), but they do provide a valuable series of public service type shows (dealing with the New York City region) which I am told are important to cable viewers in Florida, for example; where many New Yorkers go to retire. WOR currently serves about 4,000,000 cable homes nationwide. They admit they expect to lose half of those with the push off of F3R. I'd be surprised if they retain 25% of what they now have, and that will be a dollar set back to Eastern Microwave.

WOR is getting the F3R boot because Eastern Microwave has never had the bucks to be able to lay down cold, hard cash for their own transponder. They have been forced to sub-let transponder space, and the folks at Westinghouse/Showtime/TelePrompTer (now called Westinghouse Cable) own TR17. They have 'allowed' WOR via Eastern to stay on TR17 as long as they had nothing of their own to put there. Now they are 'launching' the HEALTH CHANNEL and so WOR

leaves the stability of F3R.

All of this points up what a 'thin presence' the cable industry really has on any satellite. Those cable oriented services that signed contracts years ago, and now send monthly checks to RCA for leasing on F3R, may have gotten the bargain of a lifetime. They are paying low rates (as low as 50% of the current F4 rates), they have virtually the entire cable universe locked on their bird, and if they ever tire of being on the bird (that bird) they could sub-let their space on F3R for perhaps twice the tariff they are paying. Some of them would do well to consider this; getting out of the programming business and merely renting out their bargain-rate space!

One pundit of the industry suggests that this may be exactly what does happen in a year or so; that as Westinghouse builds a stable of big, attractive program services over on W5, some of the present F3R folks may be tempted to pick up and move. As this diversification spreads, we can certainly be sure of one thing; not having a motor driven dish at a home terminal is costing the viewer more and more programming options every month!

1983. YEAR OF 12 GHz?

Virtually every week brings a new entrant announcing that they, too, will be offering a DBS (direct broadcast service) in the upper, 12 GHz, band. One of the latest to announce is the folks at Oak Industries. Oak is well known for their cable TV converters, their cable TV scrambler/descrambler systems, and their operation of over the air pay television in places such as Los Angeles.

OAK says they will, like so many other 'early entrants,' rent some transponders on the new ANIK C 12 GHz bird. C is going to be ready for occupancy early in 1983; OAK says they will start programming in mid-1983, and then switch their four channels of DBS over to US birds along about 1985.

OAK, and others, planning an 'early' start on 12 GHz DBS are aware that the ANIK C bird is designed to cover Canada. But, that because of a common border, some areas along the northern border of the USA will have suitable footprints from ANIK C. OAK plans to program to a pair of these areas; the Pacific Northwest and the largely northeastern corner of the country north of a line from Ohio to Virginia.

There is a 'rush' to go on record as being an 'early' 12 GHz DBS operator. It is infectious. In many cases it is corporate hype designed to help the entrant raise the funds needed to fulfill the pledge, or, to open the door to programming services which will be asked to offer their software (programming) for the venture.

OAK believes, and states, they will see as many as 17,000,000 US homes equipped for DBS reception by 1985. That being three years or so away, that is some gigantic leap in hardware in such a short period of time. Even at \$500 retail per package, that comes to eight billion five hundred million (\$8,500,000,000) in retail dollars being invested. No matter how you divide that up over the period mid-1983 to the end of 1985, it amounts to a huge (probably unreachable) level of product development and marketing.

OAK is no General Motors, but their corporate commitment to 12 GHz DBS certainly encourages those who feel the service might be oversold before it is born. OAK has the unique experience of software, and hardware, to give it a real run for the money. 1983 will be **another** interesting year!

ET TU WARNER?

I suppose that anything the motion picture affiliated firms do, vis-a-vis granting private earth terminal operators the legal right to view their programming, should not surprise me. Recent action by officials at Warner-Amex ('The Movie Channel,' plus MTV and Nickelodeon), therefore, should have come as no surprise.

I remember well the first SPTS gathering in Oklahoma. One of our closing sessions had a fellow named Al Parinello from The Movie Channel and Selman Kremer from Southern Satellite Systems explaining to us, as a group, why they could, would, could not or would not, grant official authorization to home terminal viewers. Kremer explained that the FCC wrote rules which made Southern Satellite Systems (common carrier for WTBS) a common carrier; that one of the rules was that the common carrier had no 'programming rights'

F3R/F4/W4 EIRP FOOTPRINTS

WHO CAN YOU BELIEVE?

One of the written, regulatory requirements laid down by the FCC, to any operator of a satellite, calls for the satellite operator to place on file (at the FCC) EIRP coverage maps; prior to the satellite's launch approval. This requirement probably stems from a set of international understandings which the USA is a party to, and to a long history wherein many classes of Commission licenses (including broadcasters) are required to show the regions they intend to cover, and how effectively they intend to cover those regions. The issue of a license (each satellite is actually granted an FCC 'license') includes, in the terms of the license, references to the coverage contours placed on file by the satellite operator.

Early filings had a checkered history. Western Union filings have proven quite accurate. Satcom filings have been less accurate. In particular, F1 predicted coverage fell far short of the in-field experience with that bird, and not a few of the regular users of that bird found themselves unable to rely on the RCA filed maps when designing suitable receiving terminals to go with the bird.

EIRP maps, of the first generation, are at best an 'approximation' of what the satellite operator anticipates will be the real world coverage of the satellite after launch, positioning, check-out and turn-on. The coverage maps are 'projections', created by computer. The computer is fed a series of antenna-range tests performed initially on the ground. The designers of the satellite transmitting antennas carefully plot the gain characteristics (i.e. pattern width, height and strength) of the antenna system on a carefully controlled antenna-environmental-test range. Such a test range can be in the open air (i.e. across a deep valley so the ground below does not distort the measurements), or in a special 'test chamber'; designed to nullify any 'reflections' from the chamber walls.

The satellite transmitting antenna is perhaps the most important single parameter on board the bird; when it comes to defining (and maintaining) a desired coverage pattern back down on the ground. From its view 22,300 miles in space, a satellite could, in fact, transmit signals to approximately 40% of the earth's surface. Intelsat birds do this, using something called a 'Global' beam. Anything the bird can 'see' (i.e. within line of sight from the bird location) gets bird signal. US and Canadian domestic birds function differently; they purposefully focus the transmitted energy that might otherwise be directed all over the (40% of) globe to a smaller region of the visible earth. How effectively this is done determines how much signal you end up with within the focus-design area.

The amount of ground signal (power) available starts out being the power of the transponder (5 or 8.5 watts) divided by, or spread out over, the portion of the earth the transmitting antenna will 'see'. Virtually all satellites employ some form of directional antenna; even the Intelsat 'global' antenna patterns are directional (they don't waste valuable transmitter power by allowing it to radiate **up**, or off to the side, **into outer space**). It is a characteristic of any directional antenna that it has gain. Your parabolic or spherical small terminal receiving antenna has gain. It obtains that gain by narrowing the beamwidth of the antenna to a fine, very narrow (approximately 1 degree) beam. You already know what happens if you re-direct your receiving anten-

na, just a few degrees, off of the satellite. The same thing is built into the satellite transmitting antenna, on a more gentle 'scale'. The typical domestic satellite has a transmitting antenna pattern that is, by design, slightly rectangular. It looks at an area which is slightly wider (east by west direction) than it is high (north by south direction). The logic of this, for North American satellites, is that our continent is wider than it is tall. Coast to coast, east by west, averages about 2,500 miles. The Canadian border, south to the Mexican border, averages about 1,100 miles. The satellite transmitting antenna builds a pattern to illuminate, or 'shine on', the selected portion of the earth below.

Hawaii, however, presents a special problem. It would certainly be possible to design a satellite transmitting antenna which would extend east by west over a 5,000 mile width; allowing coverage from the east coast to Hawaii, in one single sweep. But, between the western coast and Hawaii is nearly 2,200 miles of water. Nothing in the way of an audience here! And so, if such an antenna was lofted into orbit, it would cover about 50% ground and 50% water. The water portion would be totally wasted.

Remember that you start off, connecting to the transmitting antenna, with a fixed power level; 5 or 8.5 watts. If that five watts is focused into an area 2,500 miles wide by 1,100 miles high, you obtain a certain, measurable amount of signal on the ground. But, if you take the same 5 or 8.5 watts and spread it out over an area 5,000 miles wide by 1,100 miles high, well, the power received on the ground will be weaker. Simply because the fixed amount of power available must cover twice as much ground (/water) area.

Hawaii service, then, is done in a different way, by those satellites which have a geostationary orbit position capable of servicing Hawaii. The recently activated Satcom F4, for example, cannot provide service to Hawaii because Hawaii, from 83 west longitude, is virtually on the horizon to the west. Low look angles simply do not 'play' in this business.

Rather than spread-out the 5 or 8.5 watts over a 5,000 mile wide pattern, thereby reducing the on-ground-power available from the satellite in the 'major market' (i.e. the basic 48 contiguous states), designers of satellites wishing to serve an isolated area (i.e. Hawaii) take a fraction of the total transponder power available (typically under 1 watt), and feed it into a separate sub-antenna system. The sub-antenna system has gain of its own, and when that fractional bit of power is added to the gain of the sub-antenna system, a new, secondary antenna signal (radiation) pattern is developed.

Which brings us to the operational characteristics of the Satcom F3R satellite. By RCA design, there are two sets of six transponders which are routed to the small sub-antenna system with a 'boresight' (center) on Hawaii. Transponders 2, 6, 10, 14, 18 and 22 on the horizontal side, and transponders 1, 5, 9, 13, 17, and 21 on the vertical side are fed to Hawaii in this manner. The other horizontal and vertical transponders are **not sent** to Hawaii.

The F3R antenna system is designed to do two distinct things, then; provide so-called 'spot beam' coverage to Hawaii, at a level reduced from the main beam mainland signal, and, to provide separate coverage to the North American continent. F3R does these two things independently. The reports from **CSD** readers allowed us to create a set of field coverage maps which appeared in the March (1982) issue of the Digest. In this instance, we have field-corrected coverage maps (based upon experience) before we had the official FCC-filed RCA EIRP maps. Each EIRP map filed by the satellite operators is 'custom' for that particular satellite location. It attempts to show, in map/graphic form, what the world looks like to the satellite. Since each satellite has its own 'parking spot' above the equator, the view from each geostationary location will differ from other locations.

CSD has prepared our own versions of the RCA maps by taking the RCA filed data and converting the EIRP dBw (decibels above one watt of power) data to more easily applied antenna size displays. This means you can look directly at the maps to follow, and find the location you desire. Then check the contour lines which begin with a center 'pool' or boresight area, and expand outward from the central pool in successive rings. Each ring outward, from the central 'pool', represents a specified reduction in forecast signal level, on the ground; and as the signal level goes down (i.e. outward from the boresight spot or area) the antenna size required, to maintain a high quality picture, goes up.

SATCOM F3R/131° WEST

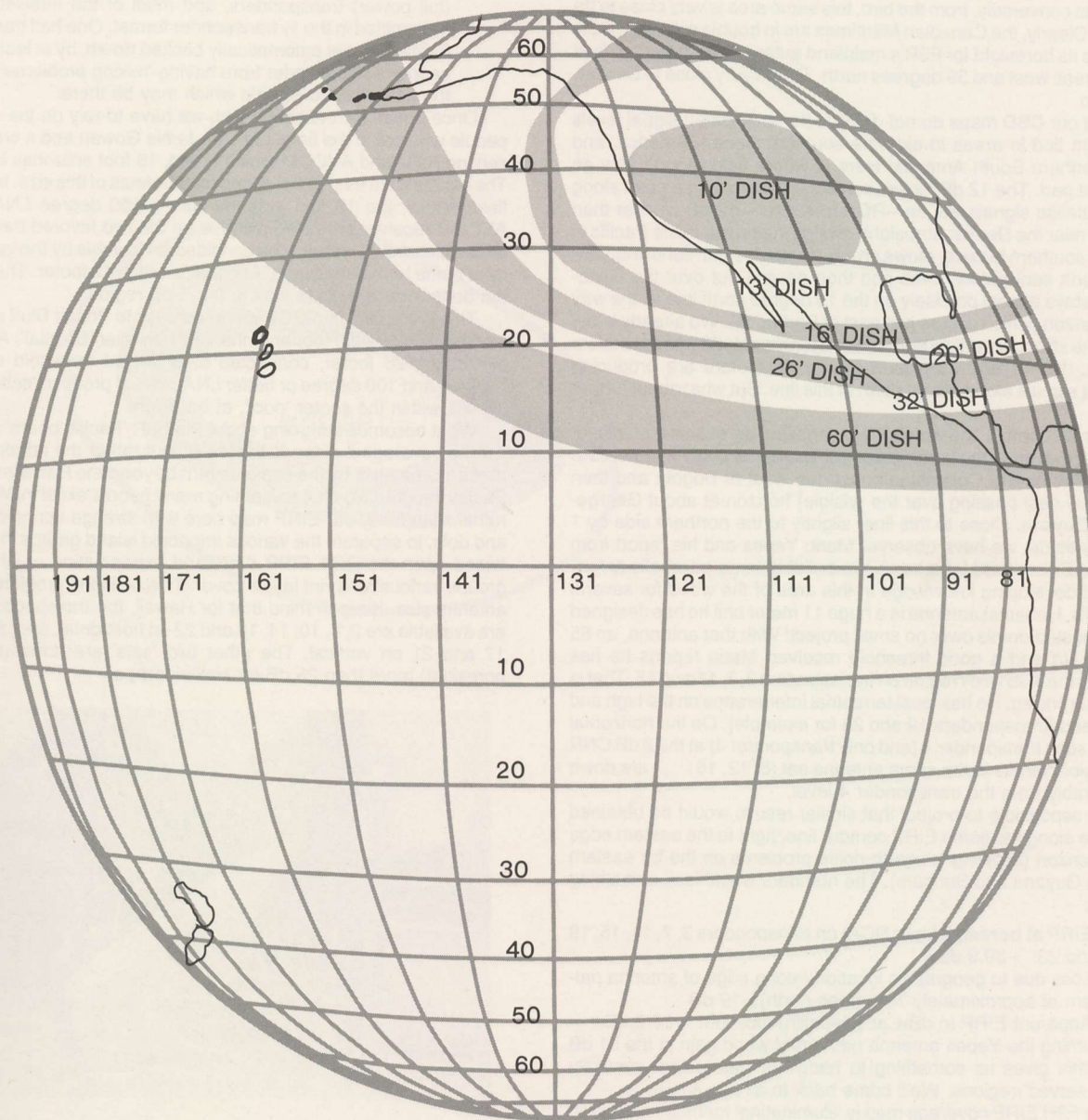

SATCOM F3R - All transponders **except** 3, 7, 11, 15, 19, 23, coverage reduced to antenna sizes required with 120° LNA, 8db CNR/threshold receiver. Data from RCA, but **not** field corrected. (**Boresight** EIRP's 37.7 dBW estimated; first contour shown is 35.7 dBW at edges.) **Copyright 1982 CSD.**

F3R: From 132 west, the F3R bird runs out of 'earth view' before it runs out of North American 'soil' along the northeastern portion of the USA/Canada. Extreme northern Maine is, for example, in the 5 to 6 degree look angle region for F3R; the bird is very close to the horizon there, and conversely, from the bird, this same area is very close to its horizon. Clearly, the Canadian Maritimes are in trouble with F3R. RCA suggests its boresight for F3R's mainland antenna beam system is at 102 degrees west and 39 degrees north. That is very close to Denver, Colorado.

What our **CSD** maps do not detail is the anticipated signal levels one might find in areas in extreme southern Central America, and along northern South America. Here is where field reports play an important part. The 12 dB 'down' contour (representing a point along which satellite signals will be—RCA forecasts—12 dB weaker than they are near the Denver boresight) swings inland out of the Pacific in extreme southern Mexico, plows on east through south central Guatemala, north central Honduras and then passes out over the Caribbean. It stays almost precisely on the 15 degree north line all the way to the horizon (which occurs just east of Barbados). We already know that on the stronger vertical antenna set (represented by transponders 3, 7, 11, 15, 19 and 23), good quality 16 footers are producing excellent signals along of and north of this line. But what about further south?

The next contour line which RCA identifies represents a point that is 20 dB 'down' from the boresight point. The 20 dB down line comes in over a point on the Colombian coast due west of Bogota and then heads due east passing over the (visible) horizon at about Georgetown in Guyana. Close to this line, slightly to the northern side by 1 degree latitude, we have observer Mario Yepes and his report from Medellin, Colombia. Mario has been building large parabolic antennas, and developing knowledge in this area of the world for several years now. His latest antenna is a huge 11 meter unit he has designed and fabricated on his own; no small project! With that antenna, an 85 degree LNA and a good threshold receiver, Mario reports he has signals in the 8 dB CNR region on transponders 3, 7, 11 and 15. That is not too surprising. He has local terrestrial interference on the high end of the band (transponders 19 and 23 for example). On the horizontal side, he sees transponder 4 (and only transponder 4) at the 8 dB CNR level region; others in the same antenna set (8, 12, 16 . . .) are down considerably from the transponder 4 level.

It is responsible to project that similar results would be obtained anyplace along the same EIRP contour line, right to the eastern edge of the horizon (allowing for earth-noise problems on the far eastern edge, in Guyana and Surinam). The numbers would look something like this:

- 1) **EIRP at boresight** (per RCA) on transponders 3, 7, 11, 15, 19 and 23: +39.9 dBw
- 2) Loss due to geographic location (along edge of antenna pattern at approximately 7 degrees north): -19 dB.
- 3) Apparent EIRP in dBw at (Medellin) location: +20.9 dBw

Assuming the Yepes antenna has a real world gain in the 51 dB region, this gives us something to hang our hats on for similarly 'weakly-served' regions. We'll come back to all this shortly.

If the F3R EIRP coverage map is 'illuminating' for those who must try to make satellite signals 'play' along the fringes of coverage, on the mainland beam, the similar map predicting coverage in the Pacific Ocean, using the Hawaiian beam antenna system, is downright exciting!

The boresight EIRP for the Hawaiian beam is in the 27 dBw region. This is roughly equivalent to what we expect from a fully saturated (i.e. high power) Intelsat 'hemispheric' beam. That suggests that for the same equivalent service contours and reception results from F3R in Hawaii, you need to be using the same type of antenna system which Intelsat Grade B terminals use for video reception. That translates roughly to a 10 or 11 meter antenna; the same size which Mario Yepes is using on F3R in Colombia. But wait . . .

If the Hawaiian EIRP is in the 27 dBw region, and Mario Yepes is working with a level slider to 21 dBw, what is the difference here? The discontinuity is traceable to two factors:

- 1) CATV systems, the primary satellite video users in Hawaii, do indeed use 10 meter size antennas. They also build into their systems a 3 dB 'margin'; i.e. they design to be 3 dB 'above

threshold', on purpose, as a safety factor.

- 2) Intelsat terminals, working with similar footprint EIRPs are actually **not** working with similar EIRPs. How's that? Well, very few of the Intelsat transmissions are through 'fully saturated' (full power) transponders, and most of the Intelsat video is transmitted in the 1/2 transponder format. One half transponder format video is automatically backed **down** by at least 3 dB, to keep the transponder from having 'mixing problems' between the pair of video signals which may be there.

Once again, for the **real** world, we have to rely on the results of people who are in the field. Last fall Jamie Gowen and a crew representing ADM and AVCOM took 11, and, 13 foot antennas to Hawaii. The results were surprisingly good for antennas of this size. In terms of field results, the 13 foot antenna with a 100 degree LNA and an AVCOM receiver produced pictures on the two favored transponder **sets** which would certainly be considered viewable by the vast majority of home terminal viewers. And that is with a 13 footer. The CNR for the better quality signals was in the 7 dB region.

This prompted Jamie Gowen to go back to Poplar Bluff and set to work designing a 20 foot antenna; his 'Hawaiian Special'. A properly performing 20 footer, connected to a decent threshold extension receiver and 100 degree or better LNA, should produce 'cable quality' signals within the center 'pool', at boresight.

What becomes intriguing about the F3R 'Pacific beam' pattern is not the coverage it extends to Hawaii, but rather the rather sizeable areas 'illuminated' by the same pattern **beyond** the Hawaiian Islands. Pacific geography is not something many people excel in. We chose, rather than filling our EIRP map here with strange sounding names and dots, to separate the various impacted island groups into listings based upon the RCA EIRP data, and extrapolation of what island groups various footprint levels cover. This boils the problem down to antenna size. Keep in mind that for Hawaii, the transponders which are available are 2, 6, 10, 14, 18 and 22 on horizontal, and, 1, 5, 9, 13, 17 and 21 on vertical. The other two 'sets' are down (reference boresight) more than 25 dB for Hawaii proper.



ADM 13 footer on beach in Hawaii was taken to the island state by Jamie Gowen (ADM), Andy Hatfield (AVCOM) and Guy Davis (now Intersat).

- 1) Where a **13 footer** will produce home-viewable pictures; Hawaii.
- 2) Where a **16 footer** will produce home-viewable pictures; Midway Island, Johnston Island, Kure Island.
- 3) Where a **20 footer** will produce home-viewable pictures; Wake Island, Kingman Reef, Palmyra Island, Washington Island, Fanning Island, Christmas Island.
- 4) Where a **27 footer** will produce home-viewable pictures; Northern Marshall Islands (including Eniwetok, Bikini), Howland Island, Baker Island, Jarvis Island, Malden Island, Starbuck Island.
- 5) Where a **36 footer** will produce home-viewable pictures; Marquesas Islands, Phoenix Islands (including Tokelau Islands), central and southern Marshall Islands.

SATCOM F3R/131° WEST

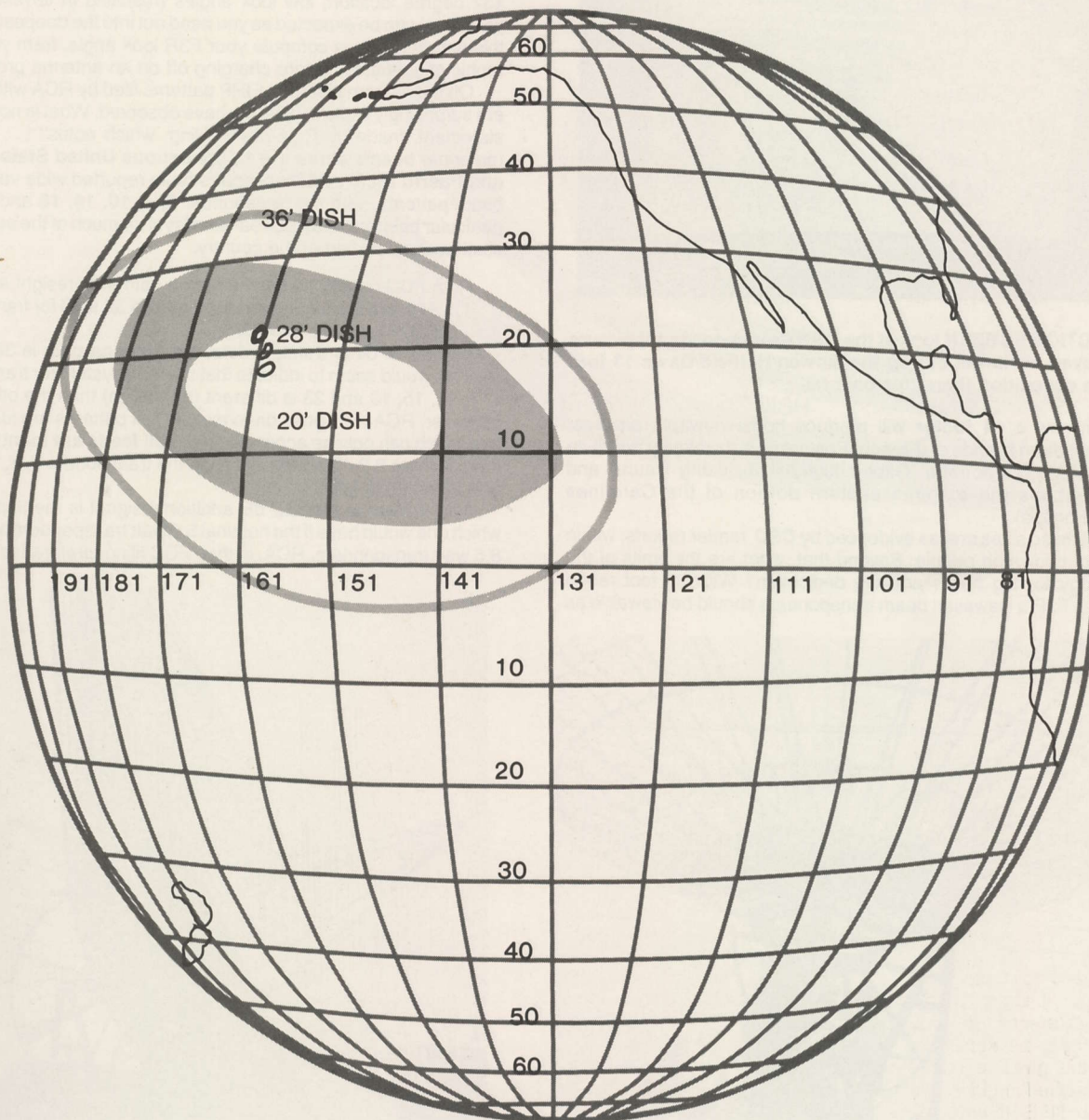

SATCOM F3R - Transponders 2, 6, 10, 14, 18, 22, plus, transponders 1, 5, 9, 13, 17 and 21 reduced to antenna sizes required with 120° LNA, 8dB CNR/threshold receiver. Data from RCA, no field-correction data available. (Boresight EIRPs 27.5 dBW; first contour shown is 25.5 dBW, estimated, at edges.) **Copyright 1982 CSD.**

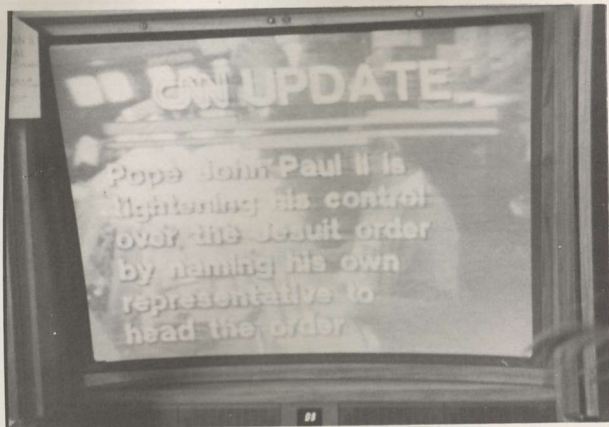

PROJECTION SCREEN look at the CNN (transponder 14) picture as received in Hawaii during the Gowen/Hatfield/Davis 13 foot antenna expedition there this past fall.

- 6) Where a 44 footer will produce home-viewable pictures; Northern Islands of (French) Polynesia, but probably **not** quite reaching Papeete; Gilbert Islands (including Nauru) and perhaps the extreme eastern portion of the Carolines (Ponape).

All of these sizes are, as evidenced by **CSD** reader reports, within 'reach' of dedicated people. Beyond that, what are the limits of the technology for big bucks and big dedication? With 90 foot range antennas F3R's Hawaiian beam transponders should be viewable as



11 METER monster designed and constructed by Mario Yepes of Medellin, Colombia has what it takes to deliver at least five above-threshold video signals deep into Colombia, from F3R.

far out as Western Samoa, and Papeete. Suva (Fiji) and the Solomons are simply too far down, and/or at too low a look angle, to make the grade. This warning about low look angles; even though the contours extend to the horizon to the west/north-west from the bird's 132 degree location, low look angles (resulting in terrestrial noise problems) can be expected as you head out into the deepest fringes of this pattern. Always compute your F3R look angle, from your geographic coordinates, before charging off on an antenna project!

Off the eastern side, the EIRP patterns filed by RCA with the FCC are surprisingly close to what we have observed. What is not 'true' is a statement, made by RCA in the filing, which notes "... **identical** (antenna) **beams serve the 48 contiguous United States, Alaska and Puerto Rico**". **CSD** observers have reported wide variations in beam patterns, with the transponder 2, 6, 10, 14, 18 and 22 set in particular being several dB weaker in level for much of the eastern and southeastern portion of the country.

RCA FCC data relates the antenna gain at boresight as follows:

- 1) At beam center, the **antenna gain** is 32.9 dB for transponders 3, 7, 11, 15, 19 and 23.

- 2) For all other transponders, the **antenna gain** is 30.7 dB.

This would seem to indicate that the feed system for transponders 3, 7, 11, 15, 19 and 23 is different (by design) than the other feeds. However, RCA then goes on to explain "all patterns are identical"; a feat which can only be accomplished if **all feeds are identical**. How, then, is there 2.2 dB added signal on the transponder 3, 7, 11, 15, 19 and 23 antenna set?

The answer is that 2.2 dB additional signal is the improvement which one would have if the nominal 5.0 watt transponders were in fact 8.5 watt transponders. RCA, in their FCC filing, preferred to **show** the

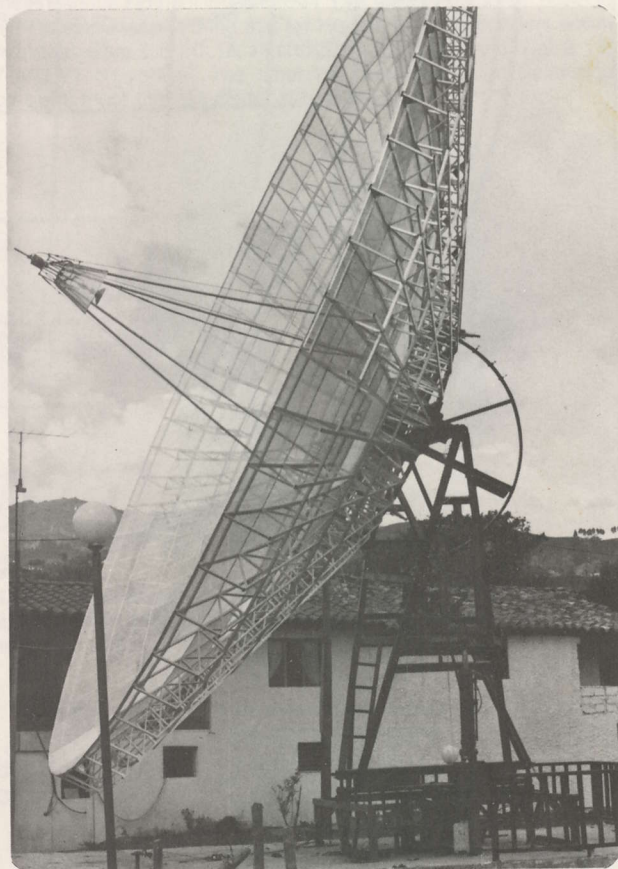

MARIO'S 11 METER antenna may be in commercial manufacture shortly; based upon his experience, gained by building several antennas and working their bugs out, he hopes to bid on the Colombian domestic terminal package of approximately 150 terminals.

SATCOM F3R/131° WEST

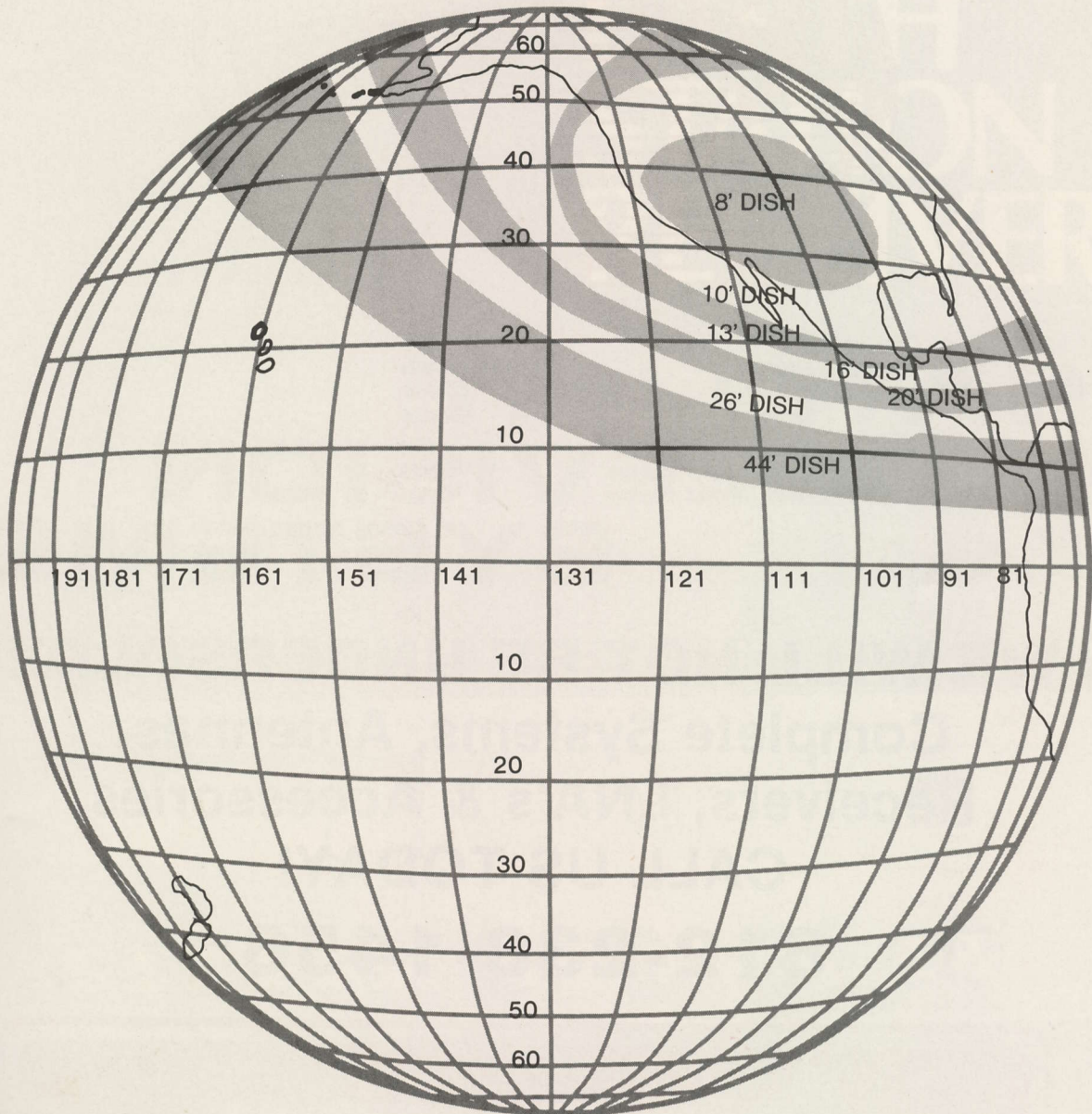

SATCOM F3R - Transponders 3, 7, 11, 15, 19, 23 reduced to antenna sizes required with 120° LNA, 8dB CNR/threshold receiver. Data from RCA, but **not** field corrected. (Boresight EIRP's 39.9 dBW estimated; first contour shown is dBW at edges.) **Copyright 1982 CSD.**



SATELLITE TELEVISION SYSTEMS

WE WILL NOT BE UNDERSOLD!!

**Complete Systems, Antennas,
Receivers, LNA's & Accessories**

CALL US TODAY!

812-238-1456

**hoosier
electronics**

"Nation's Largest Total Communications Distributor"
P.O. BOX 3300 • TERRE HAUTE, INDIANA 47803

EARTH STATION RECEIVER

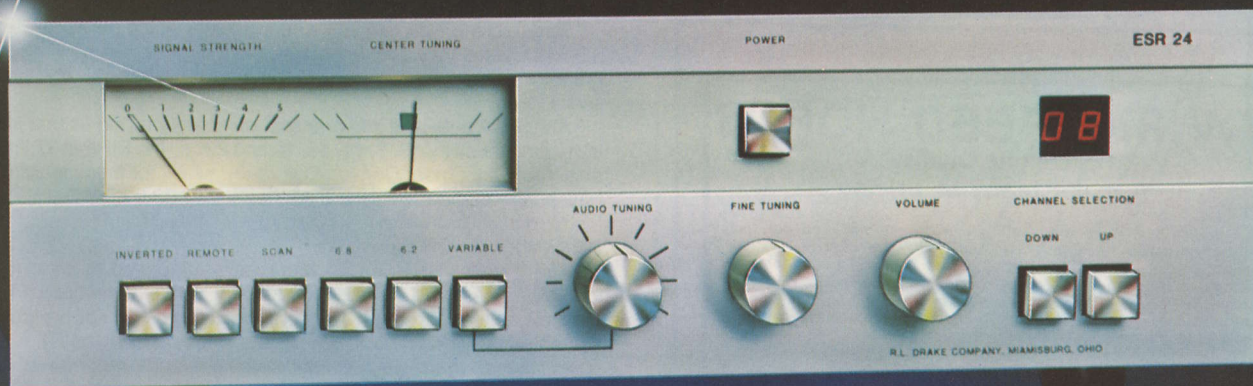

ESR24 SYSTEM

FULL PERFORMANCE SATELLITE TV RECEPTION

- All 24 Satellite Channels • Attractive Styling • Digital Channel Display
- Up/Down Channel Button Control • Normal/Inverted Video Switching
 - Fixed and Variable Audio Tuning for All Subcarriers
- Channel "Scan" Function • Remote Control and Remote Metering Options
 - AFC for Drift-Free Operation • Matching Stereo Adaptor Available

Write for Brochure or See Your Dealer



540 Richard St., Miamisburg, Ohio 45342, U.S.A.
Phone: (513) 866-2421 Telex: 288-017

increased power for these (six) transponders as a function of an antenna adjustment, overlooking or bypassing in the process its 8.5 watt capability. Prior to this revelation, RCA had announced that **four** of the 24 transponders would be powered at the 8.5 watt level; this is the first clarification of the actual operating condition, and it does 'fit' that all six transponders (rather than the 'four' announced by RCA), all on the same antenna set, are in fact a full 8.5 watts.

To the antenna gain claimed by RCA (30.7 dB for all but the higher power transponders; 32.9 dB for those six), we must add the standard transmitter power numbers, to arrive at the real world EIRP (Effective Isotropic Radiated Power). EIRP is another one of those specialized phrases, created by engineers to tell other engineers what the "secret" is. In this case, it means the following:

- 1) Any transponder has a measureable power output level. The most convenient way to measure power is to describe the number of 'watts'. Five watts, for example.
- 2) Any antenna has signal gain (or loss). Most of the antenna measurements use a reference antenna, with 0 dB of gain (i.e. no gain at all), as a standard. There are two reference antennas used; one is something called a dipole. This is an antenna you can make in your shop, and it radiates (or receives) signals equally well in a doughnut circle surrounding it. Since it has physical properties (a specified length) and form (the antenna piece is suspended in a straight line, like this - - - - -), the signal radiates from (or is attracted to) it equally well in all directions except 'off the ends'. The ends are the far left and far right sides. For highly accurate work, antenna engineers use another type of antenna for reference. That is an "isotropic" antenna. The isotropic antenna has no physical features because you cannot build one. It is a mathematical model and it radiates equally well in **all** directions. Picture a lighted globe (as in light bulb without a base to screw in) suspended in space, sending **exactly** the same amount of light **in each and every direction**, and you have a good mental picture of an "isotropic source".

- 4) A dipole, remember, does not radiate 'off the ends'. It therefore does have a 'directional pattern' of sorts, and that in turn means it does have 'gain'. A dipole can rightfully be said to have 'gain', over and above an isotropic source antenna. The amount of gain a dipole has, reference our isotropic source, is 2.1 dB. Therefore the dipole antenna's "gain" is stated as 2.1 dBi where the "i" stands for "reference to an isotropic source".

In the satellite field, virtually all antennas have gain referenced to an isotropic source. In receiving antennas, most of the firms manufacturing antennas dropped the "i" years ago. The transmitting antennas on board the birds still carry the dB "i" reference.

Which gets us back to the Effective Isotropic Radiated Power, or EIRP. Radiated power means power that has been sent through an antenna, and 'radiated'. Therefore the power, which the person tuned into the transmission 'sees' or 'measures', is the power of the transmitter **plus** the focusing or directional gain characteristics of the satellite transmitting antenna. There is one more element missing here; how do you reference power?

In the satellite field, they treat a 1 watt transmitter in the same way they treat an isotropic antenna source. It is a reference. It is the starting point. Anything stronger, or more powerful than 1 watt, is 'gain' over and above 1 watt. And because engineers like to use the decibel (dB) as a 'building block', they relate the power above 1 watt in terms of dB. Each time you double the power, you add 3 dB to the transmitted signal level. **And**, to the received signal level on the receiving end of the circuit. If 1 watt is "0 dB" (a reference point), then 2 watts (double 1 watt) is 3 dB stronger than 1 watt. The formal term utilized in this circumstance is dBw; which stands for "decibels (of power) above one watt".

The nominal 5 watt transponder is 7 dB above one watt. How so?

- 1) 1 watt equals 0 dB.
- 2) 2 watts is twice 1 watt, and 3 dBw.
- 3) 4 watts is twice 2 watts, and 6 dBw.
- 4) 8 watts would be twice four watts, and therefore 9 dBw.
- 5) 8.5 watts is a tiny fraction more than 8 watts, and it happens to be 0.2 dBw more than our 8 watt sub-reference point.

Backtracking, you can see where 5 watts would be 7 dBw, while 8.5 watts would be 9.2 dBw. Now we have all of the pieces in place to properly express, and understand, the satellite transmission power levels.

And, RCA puts it all into one final number by telling us that for all transponders except 3, 7, 11, 15, 19 and 23 . . . the EIRP is 37.7 dBw at the boresight (near Denver, Colorado); while, for those special six transponders, the EIRP is 2.2 dB 'hotter', or, 39.9 dBw.

MEANWHILE—ON F4

The Satcom F3R and F4 birds were supposed to be virtually identical in design. It turns out that this is not quite the case. F4 for example, makes no effort to serve Hawaii, so the special pair of sub-antenna systems found on F3R are simply missing on F4. Power to feed those two special Hawaiian beam antennas is 'borrowed' from the two transponder antenna sets affected; transponders 2, 6, 10, 14, 18, 22 in the horizontal field and transponders 1, 5, 9, 13, 17 and 21 in the vertical field. The amount of power borrowed, **on F3R**, to drive the two Hawaiian sub-antennas, is power lost to the same transponders for the mainland, larger, antenna beam. This accounts for the lower-than levels, on the two sets of six transponders, which are sent onto Hawaii. And this results, really, in three different types of footprint EIRP levels within the CONUS (continental United States) area; one set of transponders, 'sucked-semi-dry' by the power tapped off for feed to Hawaii, another set which is fed the normal (5 watt) power without any suck-off (transponders 4, 8, 12, 16, 20 and 24), and finally, the 'super power set' of 8.5 watt transponders (3, 7, 11, 15, 19 and 23).

The F4 bird has little of this antenna-set to antenna-set variation built-in, on purpose. What we do have are transponders 3, 7, 11, 15, 19 and 23 (just like F3R) which are our F4 'super-powered' transponders. RCA tags them with a boresight EIRP of 38.2 dBw, while the remaining 18 transponders are reported to have an EIRP of 36.0 dBw. The F4 FCC filed pattern, shown, looks pretty straight forward. RCA does not expect big, strong, signal contours to fall over the central and southern Caribbean. Remember the levels being experienced in F3R down in Medellin, Colobia by Mario Yepes? Well, RCA shows the **F3R**

T.V.R.O. FEED HORNS

Excellent Quality
A major break in pricing

Fits CP-229 Flange, has 1/4" drilled and taped holes for easy mounting. Designed for dish antennas in the .3 to .5 f/d range. Circular feeds give substantial increase in gain over other types. The dual feed has excellent separation between vert. and hor. pol. and is very low in price. Both feeds are in stock and are ready for shipment in quantities. We think you will be very pleased with the price, quality, and performance.

PRICE	F.O.B.	ST. GEORGE
	Single	Dual
one	\$55.00	\$165.00
five	46.00	155.00
ten	38.00	140.00
100	33.00	

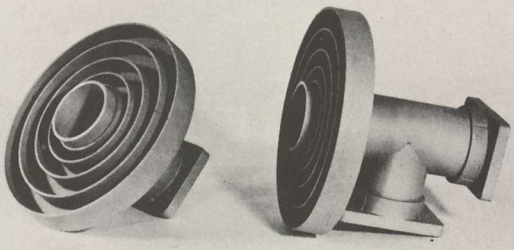

CARPENTER ELECTRIC

853 Redrock Road St. George, Utah 84770
1-801-673-2858

SATCOM 4/83° West

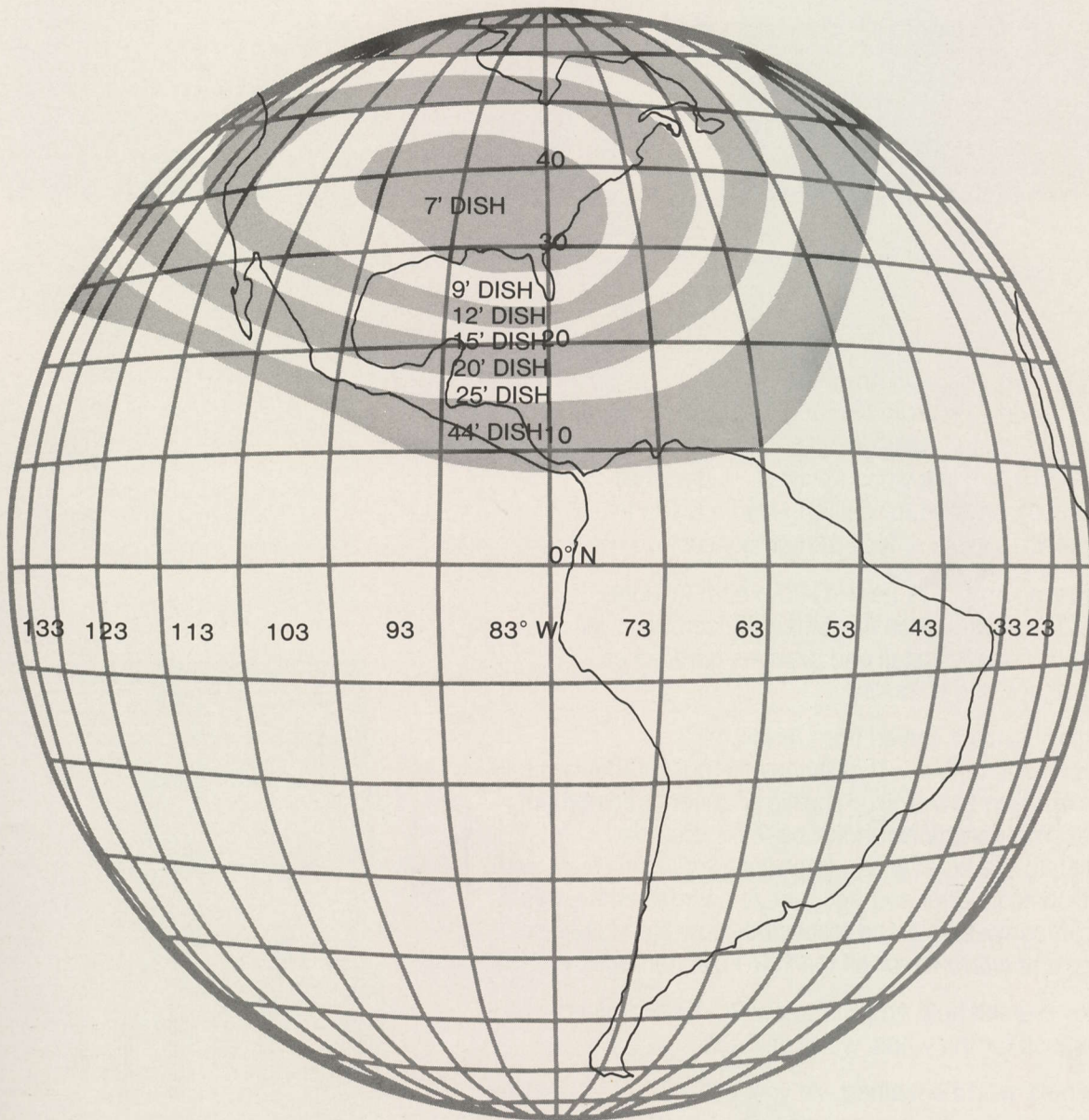

SATCOM 4 - All transponders **Except** 3, 7, 11, 15, 19, 23, reduced to antenna sizes required with 120° LNA, 8dB CNR/threshold receiver. Data from RCA, but **not** field corrected. (Boresight EIRPs RCA estimates at 43dBW; first contour line is 41dBW estimated.)
Copyright 1982 CSD.

Amplica's new RC-10: Altogether, the world of TVRO never looked so good.



Because here at last is Amplica's 120°K Model C-10 Low Noise Amplifier/Downconverter in a single rugged housing—plus Model R-10 Satellite Video Receiver, all designed and built by Amplica for optimal interface. The RC-10, all together, a system. Tested. In production.

That makes Amplica's new RC-10 a sure favorite with TVRO buyers since this Satellite Video Receiver System is easy to install and provides unmatched performance and reliability.

Especially since it comes from Amplica—pioneer in the industry. That means the quality that has made Amplica Low Noise Amplifiers standard equipment in Telecommunications and Cable T.V. systems is built into the RC-10's all-important LNA/Downconverter and Receiver. And it means that this one company—stable and respected—now stands behind service and warranty for all the TVRO electronics.

See for yourself how Amplica's new RC-10 improves the outlook for the whole world of TVRO.

The whole world's waiting—at your call.

Dealers: Call for name and location of distributor in your area.

(805) 499-2621, 2622, 2623.

- ▶ Push-button audio subcarrier selection
- ▶ Relative signal strength meter
- ▶ Interface controls for polarization selection and antenna positioning
- ▶ Video invert function

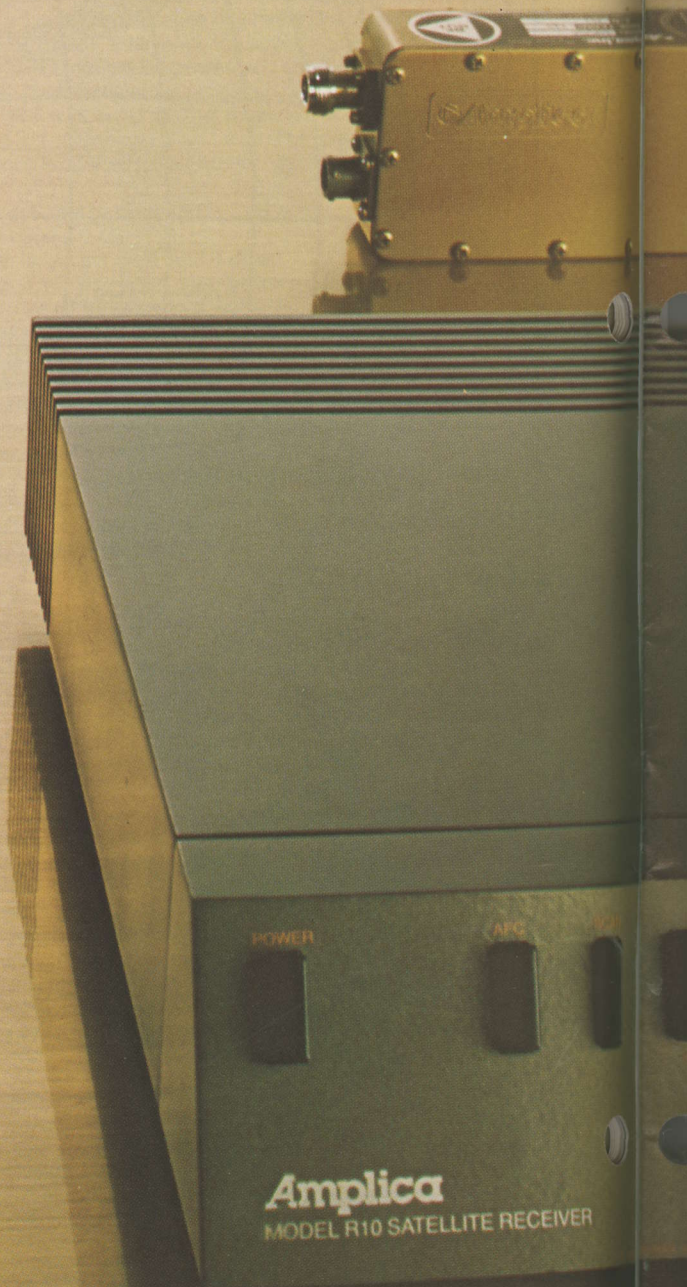

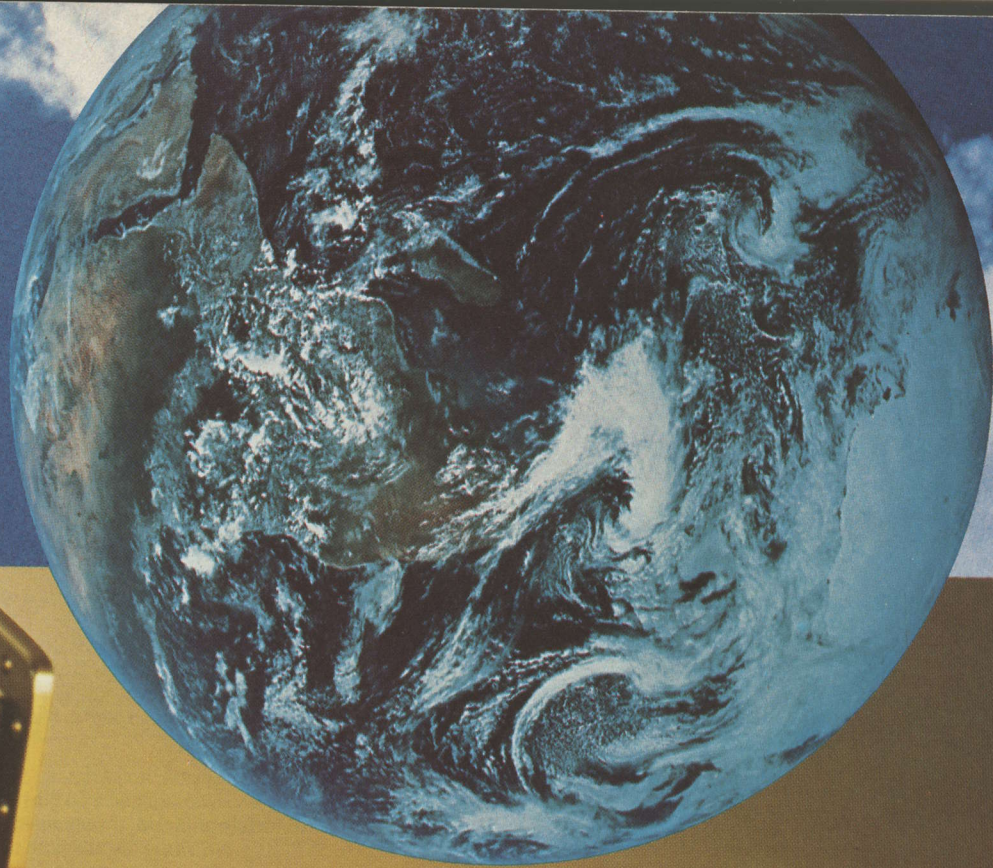

RC-10

 **Amplica, Inc.**

TELECOMMUNICATION PRODUCTS DIVISION

950 Lawrence Drive
Newbury Park, California 91320
(805) 499-2621, 2622, 2623
TWX 910-336-1291

ALINE
POLARITY
6.1
6.2
6.3
6.4
6.5
6.6
6.7
6.8
6.9
7.0
7.1
7.2
7.3
7.4
7.5
7.6
7.7
7.8
7.9
8.0
8.1
8.2
8.3
8.4
8.5
8.6
8.7
8.8
8.9
9.0
9.1
9.2
9.3
9.4
9.5
9.6
9.7
9.8
9.9
10.0
10.1
10.2
10.3
10.4
10.5
10.6
10.7
10.8
10.9
11.0
11.1
11.2
11.3
11.4
11.5
11.6
11.7
11.8
11.9
12.0
12.1
12.2
12.3
12.4
12.5
12.6
12.7
12.8
12.9
13.0
13.1
13.2
13.3
13.4
13.5
13.6
13.7
13.8
13.9
14.0
14.1
14.2
14.3
14.4
14.5
14.6
14.7
14.8
14.9
15.0
15.1
15.2
15.3
15.4
15.5
15.6
15.7
15.8
15.9
16.0
16.1
16.2
16.3
16.4
16.5
16.6
16.7
16.8
16.9
17.0
17.1
17.2
17.3
17.4
17.5
17.6
17.7
17.8
17.9
18.0
18.1
18.2
18.3
18.4
18.5
18.6
18.7
18.8
18.9
19.0
19.1
19.2
19.3
19.4
19.5
19.6
19.7
19.8
19.9
20.0
20.1
20.2
20.3
20.4
20.5
20.6
20.7
20.8
20.9
21.0
21.1
21.2
21.3
21.4
21.5
21.6
21.7
21.8
21.9
22.0
22.1
22.2
22.3
22.4
22.5
22.6
22.7
22.8
22.9
23.0
23.1
23.2
23.3
23.4
23.5
23.6
23.7
23.8
23.9
24.0
24.1
24.2
24.3
24.4
24.5
24.6
24.7
24.8
24.9
25.0
25.1
25.2
25.3
25.4
25.5
25.6
25.7
25.8
25.9
26.0
26.1
26.2
26.3
26.4
26.5
26.6
26.7
26.8
26.9
27.0
27.1
27.2
27.3
27.4
27.5
27.6
27.7
27.8
27.9
28.0
28.1
28.2
28.3
28.4
28.5
28.6
28.7
28.8
28.9
29.0
29.1
29.2
29.3
29.4
29.5
29.6
29.7
29.8
29.9
30.0
30.1
30.2
30.3
30.4
30.5
30.6
30.7
30.8
30.9
31.0
31.1
31.2
31.3
31.4
31.5
31.6
31.7
31.8
31.9
32.0
32.1
32.2
32.3
32.4
32.5
32.6
32.7
32.8
32.9
33.0
33.1
33.2
33.3
33.4
33.5
33.6
33.7
33.8
33.9
34.0
34.1
34.2
34.3
34.4
34.5
34.6
34.7
34.8
34.9
35.0
35.1
35.2
35.3
35.4
35.5
35.6
35.7
35.8
35.9
36.0
36.1
36.2
36.3
36.4
36.5
36.6
36.7
36.8
36.9
37.0
37.1
37.2
37.3
37.4
37.5
37.6
37.7
37.8
37.9
38.0
38.1
38.2
38.3
38.4
38.5
38.6
38.7
38.8
38.9
39.0
39.1
39.2
39.3
39.4
39.5
39.6
39.7
39.8
39.9
40.0
40.1
40.2
40.3
40.4
40.5
40.6
40.7
40.8
40.9
41.0
41.1
41.2
41.3
41.4
41.5
41.6
41.7
41.8
41.9
42.0
42.1
42.2
42.3
42.4
42.5
42.6
42.7
42.8
42.9
43.0
43.1
43.2
43.3
43.4
43.5
43.6
43.7
43.8
43.9
44.0
44.1
44.2
44.3
44.4
44.5
44.6
44.7
44.8
44.9
45.0
45.1
45.2
45.3
45.4
45.5
45.6
45.7
45.8
45.9
46.0
46.1
46.2
46.3
46.4
46.5
46.6
46.7
46.8
46.9
47.0
47.1
47.2
47.3
47.4
47.5
47.6
47.7
47.8
47.9
48.0
48.1
48.2
48.3
48.4
48.5
48.6
48.7
48.8
48.9
49.0
49.1
49.2
49.3
49.4
49.5
49.6
49.7
49.8
49.9
50.0
50.1
50.2
50.3
50.4
50.5
50.6
50.7
50.8
50.9
51.0
51.1
51.2
51.3
51.4
51.5
51.6
51.7
51.8
51.9
52.0
52.1
52.2
52.3
52.4
52.5
52.6
52.7
52.8
52.9
53.0
53.1
53.2
53.3
53.4
53.5
53.6
53.7
53.8
53.9
54.0
54.1
54.2
54.3
54.4
54.5
54.6
54.7
54.8
54.9
55.0
55.1
55.2
55.3
55.4
55.5
55.6
55.7
55.8
55.9
56.0
56.1
56.2
56.3
56.4
56.5
56.6
56.7
56.8
56.9
57.0
57.1
57.2
57.3
57.4
57.5
57.6
57.7
57.8
57.9
58.0
58.1
58.2
58.3
58.4
58.5
58.6
58.7
58.8
58.9
59.0
59.1
59.2
59.3
59.4
59.5
59.6
59.7
59.8
59.9
60.0
60.1
60.2
60.3
60.4
60.5
60.6
60.7
60.8
60.9
61.0
61.1
61.2
61.3
61.4
61.5
61.6
61.7
61.8
61.9
62.0
62.1
62.2
62.3
62.4
62.5
62.6
62.7
62.8
62.9
63.0
63.1
63.2
63.3
63.4
63.5
63.6
63.7
63.8
63.9
64.0
64.1
64.2
64.3
64.4
64.5
64.6
64.7
64.8
64.9
65.0
65.1
65.2
65.3
65.4
65.5
65.6
65.7
65.8
65.9
66.0
66.1
66.2
66.3
66.4
66.5
66.6
66.7
66.8
66.9
67.0
67.1
67.2
67.3
67.4
67.5
67.6
67.7
67.8
67.9
68.0
68.1
68.2
68.3
68.4
68.5
68.6
68.7
68.8
68.9
69.0
69.1
69.2
69.3
69.4
69.5
69.6
69.7
69.8
69.9
70.0
70.1
70.2
70.3
70.4
70.5
70.6
70.7
70.8
70.9
71.0
71.1
71.2
71.3
71.4
71.5
71.6
71.7
71.8
71.9
72.0
72.1
72.2
72.3
72.4
72.5
72.6
72.7
72.8
72.9
73.0
73.1
73.2
73.3
73.4
73.5
73.6
73.7
73.8
73.9
74.0
74.1
74.2
74.3
74.4
74.5
74.6
74.7
74.8
74.9
75.0
75.1
75.2
75.3
75.4
75.5
75.6
75.7
75.8
75.9
76.0
76.1
76.2
76.3
76.4
76.5
76.6
76.7
76.8
76.9
77.0
77.1
77.2
77.3
77.4
77.5
77.6
77.7
77.8
77.9
78.0
78.1
78.2
78.3
78.4
78.5
78.6
78.7
78.8
78.9
79.0
79.1
79.2
79.3
79.4
79.5
79.6
79.7
79.8
79.9
80.0
80.1
80.2
80.3
80.4
80.5
80.6
80.7
80.8
80.9
81.0
81.1
81.2
81.3
81.4
81.5
81.6
81.7
81.8
81.9
82.0
82.1
82.2
82.3
82.4
82.5
82.6
82.7
82.8
82.9
83.0
83.1
83.2
83.3
83.4
83.5
83.6
83.7
83.8
83.9
84.0
84.1
84.2
84.3
84.4
84.5
84.6
84.7
84.8
84.9
85.0
85.1
85.2
85.3
85.4
85.5
85.6
85.7
85.8
85.9
86.0
86.1
86.2
86.3
86.4
86.5
86.6
86.7
86.8
86.9
87.0
87.1
87.2
87.3
87.4
87.5
87.6
87.7
87.8
87.9
88.0
88.1
88.2
88.3
88.4
88.5
88.6
88.7
88.8
88.9
89.0
89.1
89.2
89.3
89.4
89.5
89.6
89.7
89.8
89.9
90.0
90.1
90.2
90.3
90.4
90.5
90.6
90.7
90.8
90.9
91.0
91.1
91.2
91.3
91.4
91.5
91.6
91.7
91.8
91.9
92.0
92.1
92.2
92.3
92.4
92.5
92.6
92.7
92.8
92.9
93.0
93.1
93.2
93.3
93.4
93.5
93.6
93.7
93.8
93.9
94.0
94.1
94.2
94.3
94.4
94.5
94.6
94.7
94.8
94.9
95.0
95.1
95.2
95.3
95.4
95.5
95.6
95.7
95.8
95.9
96.0
96.1
96.2
96.3
96.4
96.5
96.6
96.7
96.8
96.9
97.0
97.1
97.2
97.3
97.4
97.5
97.6
97.7
97.8
97.9
98.0
98.1
98.2
98.3
98.4
98.5
98.6
98.7
98.8
98.9
99.0
99.1
99.2
99.3
99.4
99.5
99.6
99.7
99.8
99.9
100.0

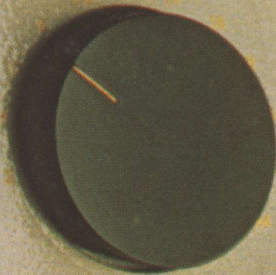

TRY IT!

YOUR SYSTEM WILL LIKE IT

ELECTRONIC

POLARIZATION

ROTATION

- NO MOVING PARTS - NO MOTORS TO FAIL - NO WAITING
- INSTANT POLARITY SELECTION WITH THE FLIP OF A SWITCH
- FINE ADJUST "PEAKING" CAPABILITY
- ELECTRONIC ROTATOR & SCALAR FEED AT ONE LOW PRICE

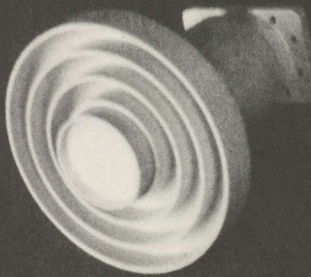

The POLATRON™

from

**INTERNATIONAL
SATELLITE VIDEO
CORPORATION**

POLATRON™ \$189.95
Controller..... 44.50
(Quantity Discounts Available)

Phone (714) 998-6080

BOX 5685

ORANGE, CALIFORNIA 92667

levels on the strongest (so-called 'super') transponders to be in the region of 20.9 dBw. Based upon FCC data on file for F4, the same transponders at Medellin will be in the 12 dBw region; far too low to detect even with Mario's 11 meter dish. Reports on F4 reception outside of the Continental 48 are slim to they don't exist, yet, except in areas immediately east of Florida (Bahamas, the Turks and Caicos). There, levels seem comparable to those found on the same transponders on F3R. However, the number of active F4 transponders, as this is written, make it very difficult to properly evaluate the performance of the F4 bird. That will come at a later date.

One of the 'problems' with F4 is its relatively easterly parking spot. You can tell, by studying the upper left hand margin of the map, that service into Alaska is at very low look angles, at best. Areas in the (U.S.) Pacific northwest have, in effect, traded postures with New England vis-a-vis the F3R bird. Their look angle to F4 is comparable to the New England look at F3R.

If there is any new ground being plowed with F4, it will be in the Maritime and northeastern provinces of Canada. Here, F4 will provide the first opportunity for US 'cable programming', since F3R is below their horizon, and out of view. It shapes up this way, based upon RCA EIRP maps filed with the FCC:

- 1) For all of Nova Scotia, antennas as small as 12 feet should produce home-viewable signals on the hotter F4 transponders.
- 2) For all of Newfoundland, antennas in the 16 foot class will provide home-viewable pictures. Labrador is similarly blessed.
- 3) For most of Baffin Island, including Frobisher Bay, a 12 footer will provide good signals although in the far northern edges of Baffin a 16 footer would be better.
- 4) Greenland is now in solid view of a US satellite, and the projected EIRP contours suggest a 20 to 24 footer will play well in such population centers as Godthaab, and, Julianehaab. In Armgagssalik, the look angle is frightfully low, although the projected contour is in the vicinity of 23 dBw (30 foot class antenna required; low look angle aside). Iceland is just out of view; sorry.

Some of the reporters already sending in material on F4 tell us they seem to be seeing slow, rolling signal variations as great as 2 dB. Daytime levels, in particular, seem to be lower than nighttime levels. The changes are gradual, but very noticeable.

Mario Yepes in Medellin finds a similar situation with the F3R signals on his hot transponder set. He sees variations approaching 4 dB, with the signal hanging below his receiver threshold by a dB or two during the daytime (on his 11 meter dish), and then building back up through the threshold point between 9 and 10 PM local time, staying at the above threshold levels until dawn of the following day. Other observations, on F3R or F4, of this phenomenon, are solicited.

When you have a low look angle (such as below 12 to 13 degrees), the incoming microwave signals can get trapped in something called a 'duct'. This is a layering effect one sees in the lower atmosphere, usually below 5,000 feet MSL. Ducts can trap signals and carry them further than they would normally go, or, if a signal has to pass through a duct at a 'shallow angle' to reach your antenna, the duct can act as a 'barrier shield' bouncing the signal away from the ground or capturing it, and carrying it within the duct (but above your head). This does not seem to be the effect noticed by Yepes; a duct in his location would tend to reduce, not enhance the signal. He considers the daytime signal levels (below threshold, slightly) the 'normal' condition, while the nighttime enhanced levels are, he believes, the abnormal conditions.

Those reporting this, or a similar observation on F4, have been largely installations where the F4 look angle is quite high; well above 40 degrees. Such a sharp incoming angle would slice through virtually any ducting observed in the past. What does track with the Yepes observations is the time frame. Those reporting this condition on F4 are seeing enhanced signals in the sundown and after period. Again, reports from additional observers, especially those located outside of the -12 dB contours for F3R and F4 (that is the sixth line out from the center or boresight 'pool' on the maps).

AND ON W4

A rather extensive report on observed Western Union Westar 4

SATCOM 4/83° WEST



SATCOM 4 - Transponders 3, 7, 11, 15, 19, 23 reduced to Antenna sizes required with 120° LNA, 8dB CNR/threshold receiver. Data from RCA, but **not** field corrected. (Boresight EIRPs RCA estimates at 45.2 dBW; first contour line is 43dBW estimated.) **Copyright 1982 CSD.**

FREE

from Satellite Services Bureau

**Home Guide to
Satellite TV**Explore
the
exciting
world of
Satellite
TV

■ Unlimited Movies ■ Cultural Events ■ Adult and Educational Entertainment ■ News and MORE

The guide will provide information for: Choosing a Dealer, Determining the Best System for you, Handling Technical Decisions and suggest how Satellite TV may change the way we live.

**Do-It-Yourself SITE
SURVEY TOOL****\$29.95**a \$49.00 Value
Refundable Too!*

*1. Return in good condition after using within 30 days and receive \$15.00 refund.

2. Full refund if you purchase a system from any Satellite Services Bureau dealer.

This professional caliber instrument helps you to quickly and accurately set compass azimuth and elevation angles and to determine the best locations to place your antenna and the programs you will be able to enjoy. Shipped with computer printout indicating all accessible satellites in North America from your location.

Mail to: Satellite Services Bureau
152 School Street, Putnam, CT 06260
(203) 928-0518 800-243-0480

- Send Free Home Guide to Satellite TV
- Enclosed is check for \$29.95. Please send Site Survey Tool and Computer Printout. (Send Certified check for faster shipment)

Name _____

Address _____

City _____

State, Zip _____

Telephone () _____ Ext. _____

activities appeared in the May CSD. We'll deal with the FCC filed EIRP maps, and what they tell us, in this report.

Westar 4 has a pair of on-file maps for their transmissions; one for the vertical transponder set, and one for the horizontal set. Both are very similar, so there is virtually nothing to be learned by studying both. But there is this notation. **W4** limits **Hawaiian/Pacific** coverage to the **horizontally polarized** antenna set. As you read through the W4 service report in this issue, you will discover that this is the odd-numbered channels (i.e. 1, 3, 5, etc.); totally backwards from the Satcom birds!

The boresight, which is supposed to be someplace close to Tulsa, Oklahoma, reportedly is at +38 dBw. The initial contour lines are in 2 dB steps so the first set outward from the central 'puddle' is the 36 dBw line.

The Hawaiian boresight is **reported to be** 25.5 dBw, and the first set of contours out are down only 1 dB. The Hawaiian contours are a bit of a mystery at this point. There is a need for observers in Hawaii to compare the horizontal transponders on W4 against levels from F3R. Given that data, a more accurate estimation of what to expect from W4 in the Pacific can be pieced together. For now, it looks like 10 meter antenna territory.

Western Union antenna patterns have traditionally been 'tighter' than Satcom antenna patterns; and W4 is no exception to the rule. They also tend to be more closely related to field results (maps on file versus real world results), than Satcom. If that holds true for W4, here is what we **should** expect in some of the fringe areas from W4.

- 1) **All of Labrador** should find good quality (home viewable) signals on W4 with a **16 foot** antenna.
- 2) **With 30 foot range antennas**, the signals **should** still be usable as far to the east as Anguilla, south to Martinique region. Levels further east, and south, are forecast to drop off rapidly, however. For example, the level at Medellin, Colombia is not supposed to exceed 12 dBw! The southern edge of the 30 to 40 foot antenna useful range would appear to be cutting through Belize, on east to Martinique. Even levels in central Mexico are forecast to be in the 25 to 30 foot antenna (required) range.

So what do the FCC filed EIRP/contour maps tell us? Well, most of all they tell us what the engineers and technicians who have designed and constructed the satellite system 'hope' the bird will do, once into orbit and 'on Clarke Orbit station'. Just a few years back, EIRP maps were taken as gospel. People designing terminal systems had no data but these maps, and were forced to put together systems which reflected the 'ideal' coverage levels forecast by the satellite designers. Now, with thousands of terminals operational, we have a feedback loop in operation, and after a relatively short initial operational period, the data begins to build into a solid set of maps for a new bird. We are in that building stage, now, for the W4 and F3R, F4 satellites. The next time we visit a full set of maps for these birds, we'll be looking at the combined observations of thousands of terminals.

**MOISTURE
NO FRIEND
AT 4 GHz**

One of the peculiar properties of super high frequency (SHF) radio energy is that such energy does not care to get 'wet.' A micro-thin layer



WESTAR 4 - All 24 Transponders Rated with identical patterns by Western Union. All data from Western Union; **not** field corrected. Boresight on Conus beam estimated at 38 dBW. Boresight on Hawaiian beam estimated at 28 dBW. All contours away from boresight in - 2 dB steps.
Copyright 1982 CSD.

of water, wedged down between the male pin and the female receptacle of any connector between the LNA output, and the input to the TVRO receiver, will cost you either some, or all, of the precious little 4 GHz satellite signal you have available. In short, even a 'damp' connector can 'short out' satellite signals.

This suggests that all connectors, carrying 4 GHz signal energy, must somehow be very well protected so that moisture can not seep from the normally-exposed-outside of the connector, to the normally dry inside of the connector. There is, however, more to the basic problem than merely keeping water out. That problem is electrolysis.

Electrolysis is a chemical reaction, between two or more separate pieces of metal, when there is a 'catalyst' present. Water is such a catalyst. But there is another ingredient which can speed up, and modify, the electrolysis. That ingredient is (DC) electricity. We can all observe the electro-chemical activity of the marriage of (dis-similar) metals, moisture and (DC) electricity by simply lifting the hood on a vehicle and inspecting the battery terminals. That white, chalky compound that eventually may turn a greenish tint is the residue or product from electrolysis. As you might suspect, the chalky compound is not good for the flow of electricity. It is worse than not good for the flow of 4 GHz satellite signals. It is a disaster.

Most of the transmission cables that interconnect the TVRO LNA (or LNA plus downconverter in LNC packages) are copper; either solid copper, or, copper clad aluminum. Copper is a particularly 'active' element when moisture and DC are applied to it. The electro-chemical reaction that accompanies this 'marriage' is very dangerous for the TVRO system installer.

Most LNAs, and all LNC units, require a DC operating voltage applied to the outdoor portion of the unit. There are two ways to get that DC voltage to the unit; through the downline coaxial cable, or, through a separate run of power cable. In some installations the 'powering' cable is simply some low-cost RG-59/U coaxial cable pressed into service to carry DC.

We therefore have a pair of separate, but related, problems.

- 1) We must keep any signs of moisture out of the RF transmission line system, especially when the RF transmission line is carrying 4 GHz satellite energy from the LNA to an indoor (receiver/downconverter) location, and,
- 2) We must keep moisture out of any powering or control lines when the voltage being carried in the lines is a DC voltage.

DC (direct current) voltage is the same type which you find in your auto battery. Or in your flashlight batteries. Thomas Alva Edison and others found DC to be superior to AC for many applications, but they kept having problems with the DC 'connections' when the connections were outside. A couple of generations later, the young cable television industry would re-discover the same problem all over again.

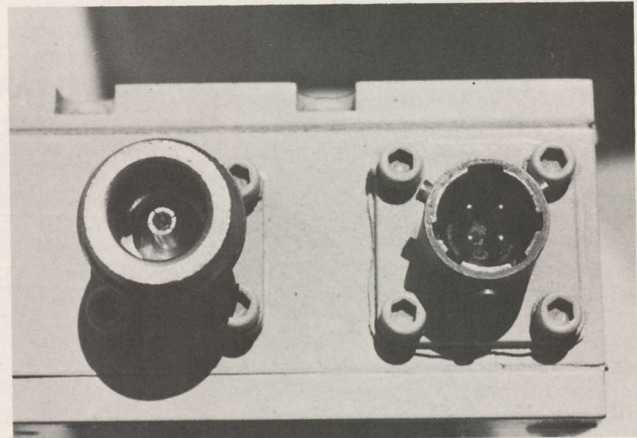

TWO POINTS OF ENTRY — in typical LNA package. RF connector (type 'N') is on left ; powering plug is on right. Powering connections require great care because the wire-end of fitting cannot handle wire diameters over #20/22 safely.

Cable television 'line' amplifiers (the aluminum-housed boxes that hang up there on the poles 'boosting' the cable signals along the lines) were in the 50's and early 60's tube type amplifiers. Each amplifier location required a 110 VAC power 'drop.' Then along came a small firm in north Texas named CAS and another firm in Canada named BENCO. Both announced all-transistorized (i.e. solid state) 'line' amplifiers along about 1960. Both designed their outdoor-hung amplifiers so that they would be 'line powered' (i.e. through the coaxial cable) by a DC voltage. They were not unmindful of the potential for DC activated 'electro-chemical' reactions. They had simply not done their homework properly, and did not know (at the time) just how much direct current needed to be drawn through a connection, and how much moisture had to be present in the connection, to set off electro-chemical reaction.

The DC 'line powered' cable TV amplifiers lasted a very short period of time; until the first wet season. They were promptly taken off the market (after futile attempts to seal the connections in the field) and replaced with AC (30 volt initially) line powering. Since the transistorized line amplifiers still operated on DC, each line amplifier 'got bigger' because each line amplifier had to have a 30 VAC input, lower voltage DC output power supply built into the unit.

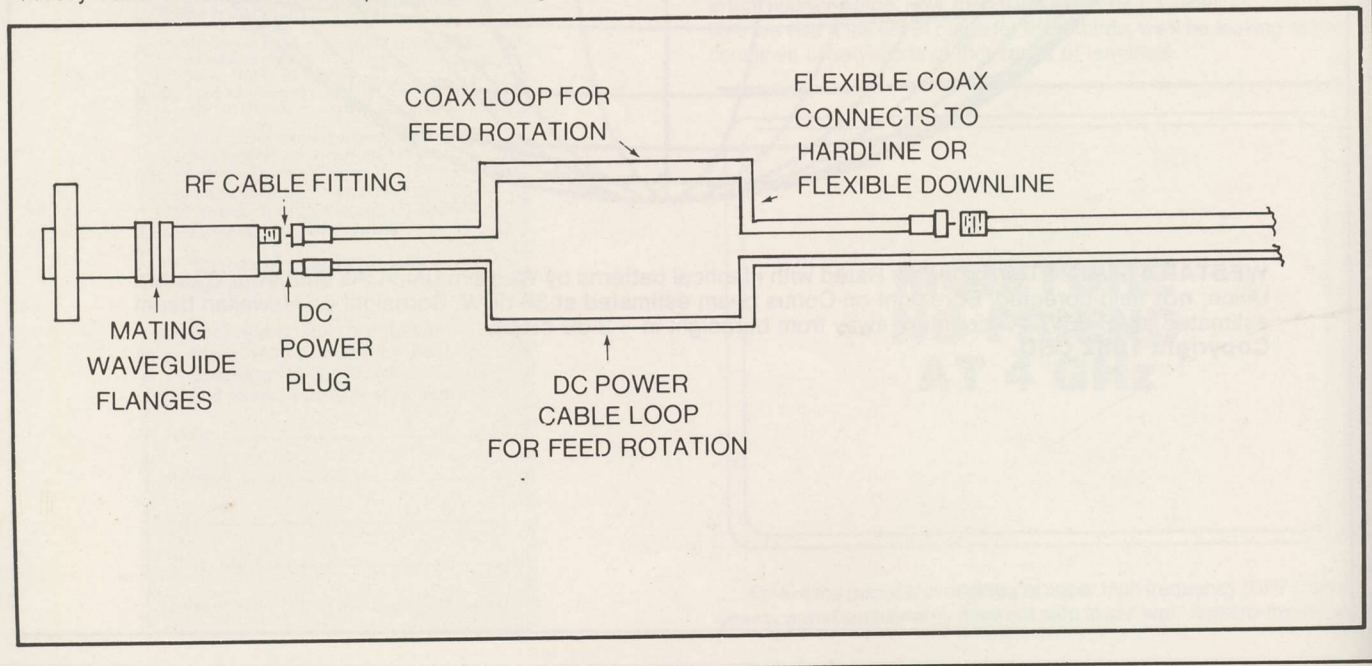

INTRODUCING: TRACKER III
COOP'S SATELLITE DIRECT
PAGE 33 COL 45

Two New Products from Chaparral:

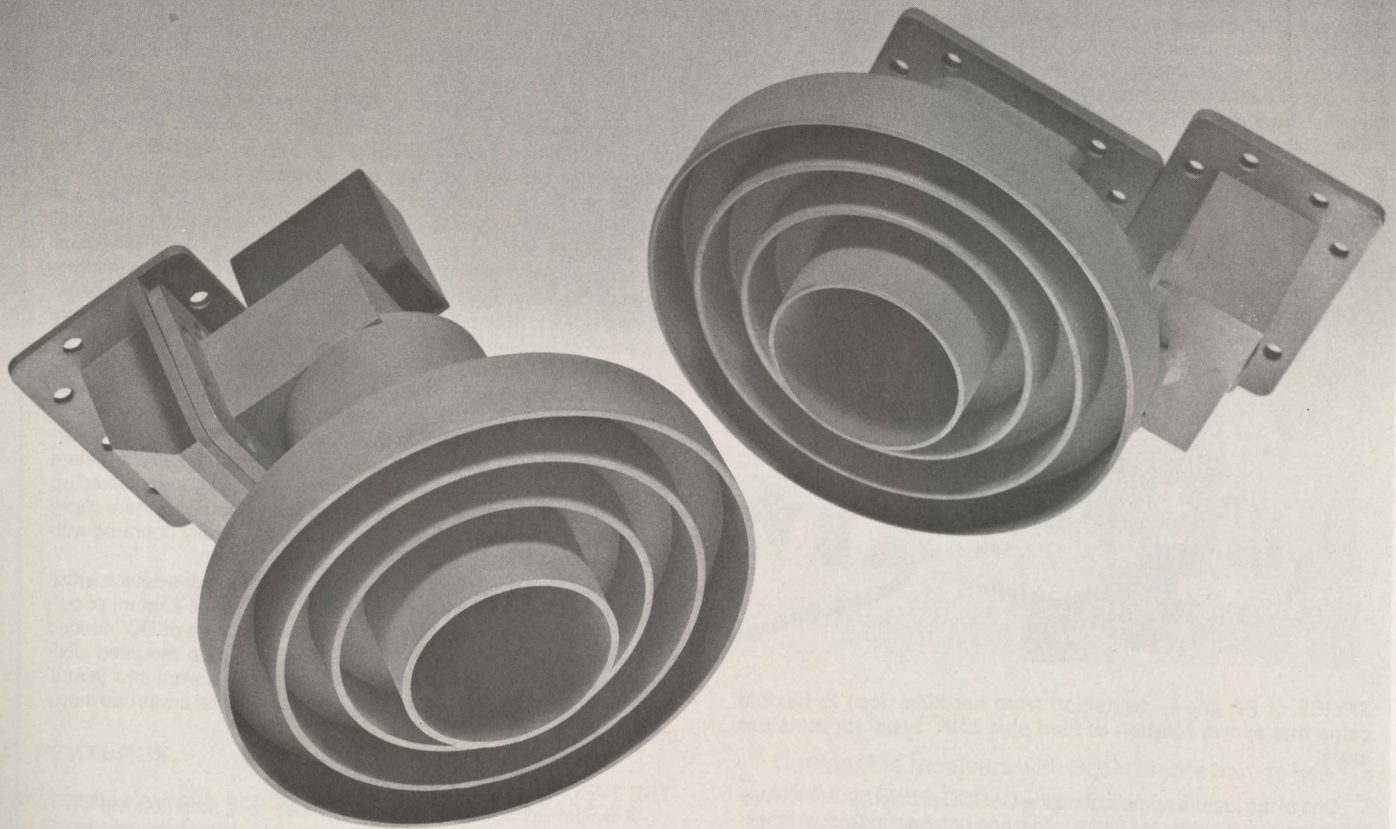

POLAROTOR™ DUAL FEED II™

POLAROTOR™

Change Polarization without a Rotor, and with Performance that Equals the Chaparral Super Feed™.

With the Chaparral Polarotor™, antenna polarity can be changed in less than half a second. Inside the circular waveguide of the Polarotor™, a probe is rotated by a small servo to any position over 180 degrees with one-degree accuracy. The feed and the LNA remain fixed. Only the probe moves.

DUAL FEED II™

Performance and Economy, with Chaparral Quality

The Chaparral Dual Feed II™ applies an innovative design to produce a high-performance orthomode feed at low cost. For compact installation, both LNAs can be mounted to the rear. VSWR is better than 1.4/1, and isolation is at least 30 dB.



Chaparral Communications:
103 Bonaventura Drive, San Jose, CA 95134, (408) 262-2536

Chaparral: Innovative design, Imaginative engineering, Quality manufacturing.

The next attempt to line power, with DC, outdoor mounting RF amplifying equipment for the cable industry, came in 1970. A firm called CADCO had developed a line of antenna mounting, extremely low noise (for that period of time) pre-amplifiers. The VHF and UHF signal pre-amplifiers were designed to be installed right at the off-air antennas, on the towers. The field effect transistor (FET) amplifier stages operated on around 10 volts DC, and drew relatively small amounts of current per stage (typically under 10 mA). A four stage amplifier drew under 50 mA of DC current, and after some arguments the decision was made to line power the amplifiers with 12 volts of DC (zener regulated down to the proper operating voltage per stage inside the unit).

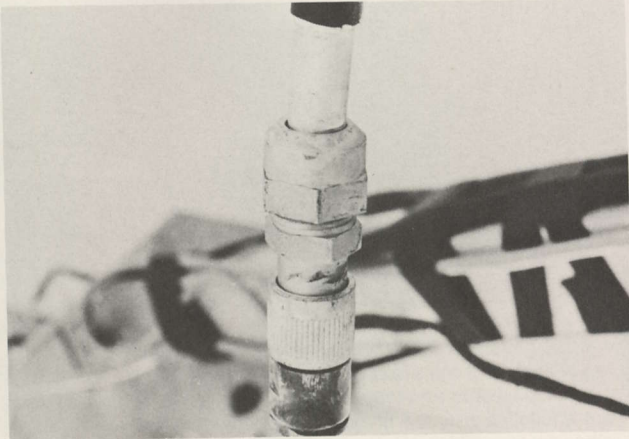

SPLICE of RF line — transition from hardline (top) to flexible cable that allows rotation of feed plus LNA 'begs' for moisture entry.

One of the factors complicating the CADCO problem was their use of printed circuit bandpass filters within and between individual amplifier stages. The (patented) design used etched-on-G10 PC board 'coils'; replacing the normal air or form wound coils one finds in most tuned circuits. The precision etched-inductors (coils) made it possible to control very closely the bandpass characteristics of the individual amplifier stages. But the use of a wide open copper board, forming not only the usual point to point connections, but also the critical coil or inductor function, presented a new set of challenges. Moisture had to be kept out of the containers!

Their solution, for these tower mounting amplifiers (which often ended up 800 or more feet above ground; in the worst kind of natural environment!) was to develop a cast aluminum housing, sealed with both an 'O' ring and a full cover 'gasket.' Then the gasket was coated with a liberal coating of jellied silicone seal to bind between the 'O ring' and the gasket seal. High torque bolts tightened the full width and length back plate lid down very tightly 'cramping' the 'O ring' into the gasket and silicone seal.

Having prevented moisture from getting into the housing where the housing came apart, that left the input and output connectors. The circuit board for the amplifier laid out so that the etched-on-G10 board spiral inductors ran the full length of the board. There was an input 'end' to the board, and an output end. The input end faced upwards, and on that end of the cast aluminum container was a single weather-proof F series chassis mounting fitting that was screwed into the housing; the housing being tapped for the thread-in F series fitting. The fitting was further silicone sealed on the inside of the housing after being torqued into the screw-in case hole. When the installer placed the amplifier into service, the input connector was typically a short pigtail of high quality RG-59/U cable that looped from the VHF or UHF off-air antenna directly to the fitting. The outside portion of the connector would be weather sealed with a silicone or caulking compound.

The top (input) fitting was directly exposed to rain while the output fitting was on the opposite end, facing downwards towards the ground. It also threaded into position and was sealed like the top, input fitting. **BUT** — unlike the top fitting, the bottom one carried both RF

and DC.

This may seem unnecessarily detailed in describing a product which has no direct application to the TVRO world. The lessons learned with this particular CADCO pre-amplifier are applicable however.

With this sealing, the unit performed just fine when properly installed. 'Properly installed' included an installer responsibility to seal with silicone and caulking compound the input and output fittings, and to be sure that the high torque bolts holding the back plate to the cast housing were indeed tight. It worked without weather interference about as reliably as the modern day TVRO LNAs, which have similar design problems when it comes to weather protection.

After several years of successful operation, no reported cases of electrolysis, CADCO decided to take their largest housing (a low band VHF amplifier) and cram both a UHF pre-amplifier (relatively small circuit board) and a UHF down converter into the housing. Everything stayed the same, except that now the total current drain of the package was close to 100 mA at 18 volts DC. And that opened an entirely new world of problems.

After many field failures it became apparent that the slight (50%) increase in voltage (from 12 to 18 VDC), and the doubling of current being drawn through the cable, was enough to trigger DC activated electro-chemical electrolysis in those environments where the average humidity was high. They were re-discovering the same problem the first CATV line amplifiers had discovered, but they had worked up to the 'critical' voltage and current level from a design where there were no such problems. CATV line amplifiers typically operated with 20 to 30 volts of DC and drew around .2 amp each.

The cross-over point, between being able to power a device with a relatively low (DC) voltage drawing a relatively small amount of current, and not being able to get away with it because of DC induced electrolysis, was not uniform. The CADCO antenna mounted UHF pre-amplifier and down converter combo units that went into 'inland' areas had few problems. Those that went into coastal areas had many problems.

THE TVRO ELECTROLYSIS PROBLEM

A typical DC powered LNA draws close to .2 amp (like the CATV line amplifier) and the line powering voltage is in the vicinity of 12 to 18 volts. It may be as much as 25 volts with some receiver powering supplies. This would appear to be a 'border-line' situation where electrolysis will be a function of the average amount of moisture in the area. And how well that moisture is kept out of the electronics.

A typical DC powered LNC has reduced LNA portion current drain (most of the current drawn by an LNA is taken by the 'bulk gain' stages of the LNA, which are eliminated in an LNC); in the vicinity of 25 mA for a pair of stages. However the downconverter may draw as much as .3 amp and now we are in the 'battery' business, potentially creating a considerable amount of electrolysis. This assumes that the down-converter is in fact DC powered via either the coaxial line, or, via its own dedicated power line.

There is apparently no magic 'safe level' of voltage and current, nor a plateau below which you cannot have electro-chemical electrolysis. If you get sufficient moisture into the act, even small amounts of current are capable of starting the chain reaction.

Which says that somehow you must eliminate one of the ingredients that are essential to the process. The moisture seems like the most damaging part of the equation since even lacking a DC voltage (and current) the presence of moisture in a 4 GHz coaxial fitting can put your system out of commission. Let's look at the connectors first.

- 1) Virtually all connectors use a silver plated material. Silver will tarnish (oxidize) and oxidized connector center pins or receptacles cut down the efficiency of the 4 GHz energy transfer (from male to female or vice versa) from connector part to connector part. All fittings have some (measurable) loss; tarnished or corroded fittings have increased loss.
- 2) Loss ahead of the LNA can be disastrous even if it is very small, since your Carrier to Noise ratio prior to signal amplification is almost zero. Very few installations separate the feed from the LNA, and require a coaxial cable transition or coupling. Those that do, however, are asking for big problems.
- 3) Loss in fittings that come **after** the 4 GHz LNA (and while the

INTRODUCING: TRACKER III

Advanced Microprocessor Technology for the 80's

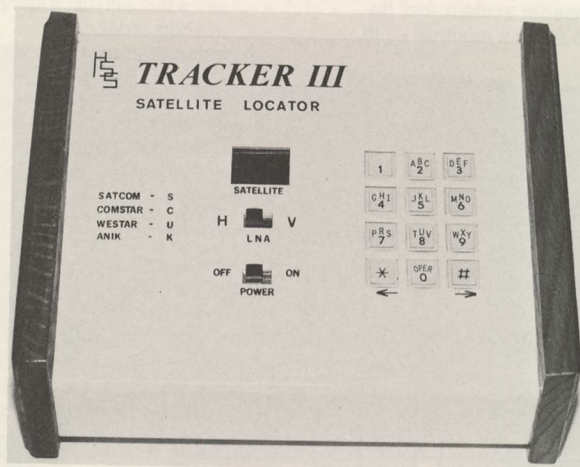

Get the most out of your Earth Station with the Tracker III

SYSTEM FEATURES

- LED digital display with actual satellite designation and tone to indicate when movement is complete. (also shows direction of dish travel with "chaser" line on LED display)
- Easily programmed for pinpoint stopping on all present and future satellites in the U.S. domestic satellite belt. (up to 70 programmable positions)
- Provides programmable horizontal and vertical polarization for satellite position for use with rotatable feed systems with Alliance rotors. This allows programmer to compensate for "skew" across the arc.
- Memory Store with battery backup that will hold programming of satellites and polarity for the life of the battery pack.
- Programmable E-PROM that can be updated when more features become available. (this unit never becomes obsolete)
- Microprocessor controlled with the latest TTL and C-MOS technology available.

- Compatible receivers with BCD remote can be used to control LNA rotation.
- Attractive control box that will operate the dish movement up to 1500 feet away.
- Power jack (actuator) with built-in Hall Effect sensor with adjustable saddle clamp to fit most polar mounts.
- Can be used with most any jack, no matter what stroke you require.
- D.C. low voltage to the actuator.
- Manual override capability.
- Can be adapted to most polar mounts.

OPTIONS

- Hall Effect sensor can be easily field installed in your actuator.
- Interface box or schematic can be provided to build your own.
- Interface box can be adapted to work with 110v A.C. actuators.

TRACKER SYSTEMS

The most dependable Satellite Locators your money can buy!

A Division Of:

HOUSTON SATELLITE SYSTEMS

8000 Harwin, Suite 397 • Houston, TX 77036

713/784-8953

signal is still at 4 GHz, prior to down conversion) is not quite such a disaster. The loss can be tolerated provided it only amounts to a few dB, since the loss is pure voltage and most LNAs have so much gain that you have 'voltage' to 'burn' or lose; after the LNA. However, if the coaxial line is carrying a DC voltage to the LNA (using a power inserter system that duplexes the DC voltage and the 4 GHz signals together — in

opposite flow directions — onto the same cable), the moisture that can 'tarnish' or 'oxidize' the fittings in the chain can, with DC present, also start electro-chemical electrolysis. So while you can afford, perhaps, to lose a couple of dB of signal 'voltage,' you cannot afford to allow electrolysis to get started since this will ruin a fitting and cost you far more than a few dB, in short order.

A system that utilizes a separate (dedicated) power line for the LNA supply voltage does have the advantage of limiting electrolysis damage to 'only' the powering line. A failure of a (moisture impregnated) powering line will shut down the powering to the LNA, but not cut down on the 4 GHz energy that is flowing to the receiver from the LNA in a separate (dedicated) coaxial line. Repair is a matter of cleaning up a 'DC cable,' not a complicated problem of tracing and correcting corroded 4 GHz fittings and metal to metal contacts.

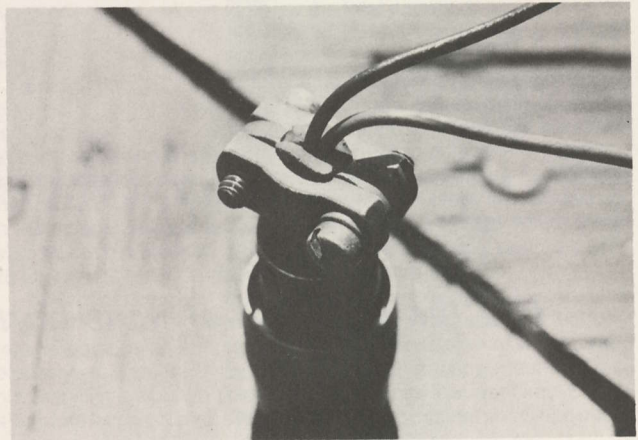
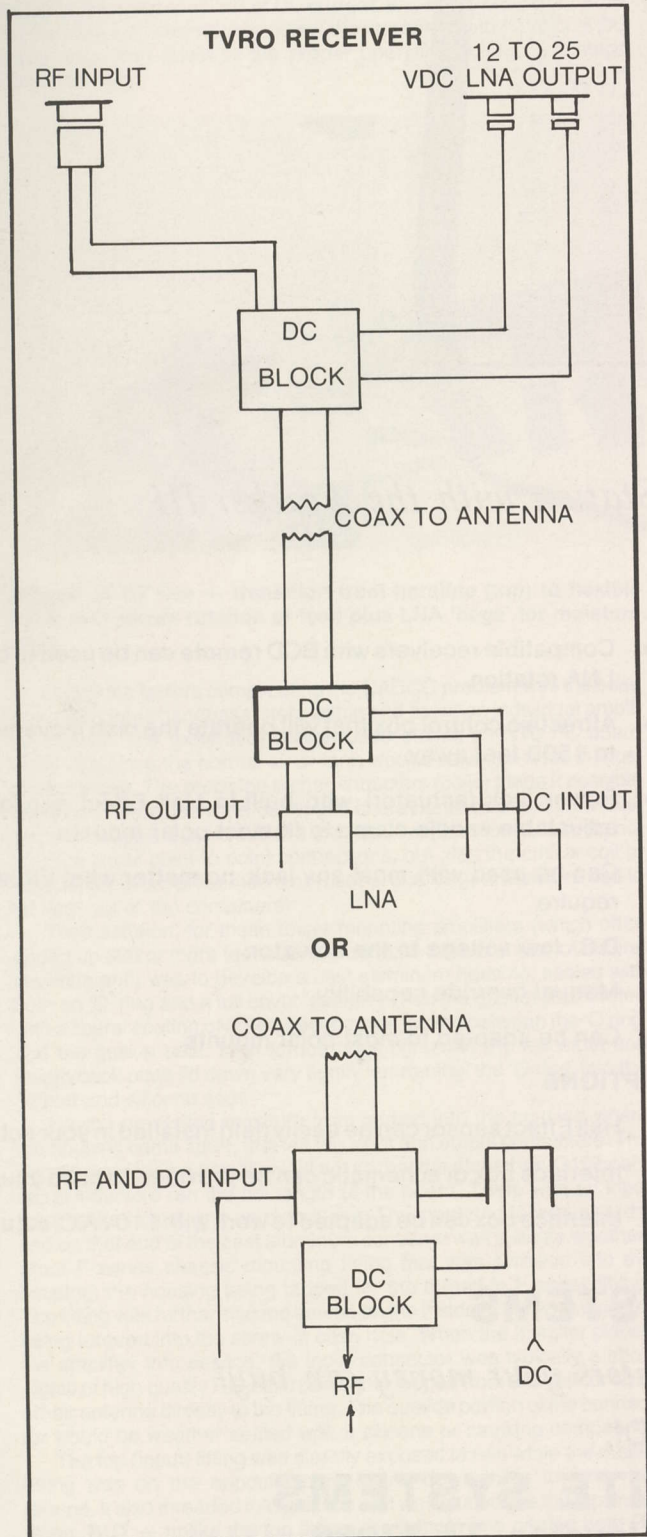

UNPROTECTED — DC powering plug is fitted with weather protection sealing grommet. Unfortunately the plug faces 'upwards' into the sky and rain can puddle inside of fitting.

DETECTING CORROSIVE CONTACTS

A number of things will happen, usually slowly, when moisture works its way into a TVRO system. Abrupt failure, putting you out of commission one minute, after you had normal ('perfect') pictures the prior minute, are seldom traceable to a moisture fault.

- 1) LNA powering systems that run the LNAs off of a 12 VDC (13.8 VDC nominal) 'off-the-shelf' DC power supply are nearly in trouble to begin with. Most LNAs are designed to operate with an input voltage from 12 to 15 volts DC (low end) up to 25 volts on the high end. TVRO receivers that 'tap' into their own internal DC supply lines to allow you to power the LNA typically provide voltages above 15 VDC but below 25 VDC.

When you elect to use a commercial 12 VDC supply, which typically provides someplace close to a regulated 13.8 VDC output, you are close to the 'bottom' of the recommended DC input 'window' for the LNA.

Inside of the LNA, the actual operating voltages are typically just at or below the 10 volt point. This tells you that whatever the line powering voltage may be, it is regulated down to something near 10 volts internally; for the best combination of voltage and GaAs-FET device operating current to produce the best gain and noise figure combination. However, this is not all that there is to that story.

If an LNA tells you it wants to see +15 VDC (i.e. such as the Dexcel units), that could mean that a 13.8 VDC supply might be a marginal supply. Especially if corrosion works its way into the LNA powering system.

When corrosion (tarnished contacts, or electro-chemical created electrolysis) attacks, the resistance of the DC powering circuit increases. In effect, you have a (DC) voltage drop across the corroded contact or splice, and that voltage drop may lower the supply voltage to the LNA where the internal voltage regulation system can no longer perform properly. The effect is that the LNA begins to lose gain, and more importantly, without the proper 'optimized' voltage to the first

ADVANCED COMPONENT CONTROL



Channel Master introduces state-of-the-art microwave technology.

Built to commercial performance standards and designed to provide the viewer with complete control and repeatability. Every detail of the new Channel Master earth station receiver has been carefully considered, right down to the high tech cabinet designed by an industrial designer famous for audio component development. Easy to operate, this receiver provides improved video performance with such advanced features as:

- Signal and Channel Tune Meters ● Automatic Polarity Switching ● Priority or Variable Audio Tuning ● Remote Control Option ● Built-in Modulator ● Channel Scan ● Full Video and Audio Fidelity ● Superior Threshold Performance.

SATSCAN is a key part of the new Channel Master system. Using simple UP/DOWN push buttons, the operator can change satellites at any time with pinpoint accuracy, without leaving the house. It features LED digital read-out, automatic safety shutoff, a satellite reference card, low 12 volt DC operation, analog feedback with power-loss memory, and variable distance selection (up to 1000').

In addition to this brand-new line of advanced equipment, Channel Master distributors offer you the advantage of low initial investment, expert assistance, local inventories, a total system warranty, marketing and sales support, and portable TVRO demonstrators. And, even with all of this, dealer cost will actually be less than it was last year!

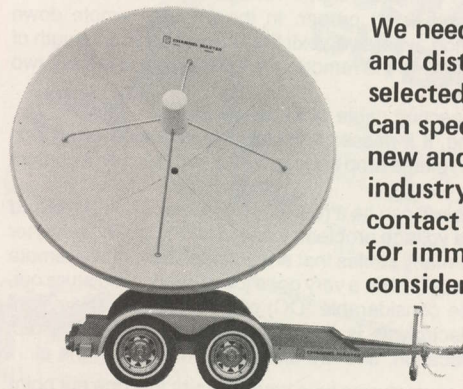

We need new dealers and distributors for selected markets who can specialize in this new and growing industry. Please contact Donald Berg for immediate consideration.



Channel Master[®]

Div. of Avnet, Inc., C682, Ellenville, N.Y. 12428
(914) 647-5000

couple of GaAs-FET gain stages, that critical balance of best operating voltage and gain is lost. This can cause the LNA's first couple of stages (where the low noise figure for the LNA is established for the whole receiving system) to operate out of kilter with their original design parameters. A voltage drop, due to corrosion in the powering line, could cause an LNA that checks out as an 85 (or 100) degree unit at the factory to have a substantial noise figure increase in the field. The LNA may not actually **stop** working until the voltage drop is substantial; but the performance level of the LNA can change so slowly, as the corrosion eats into the DC powering line, that the change to the eye over a period of days is not even noticeable.

To complicate matters, because the wiring often used to jumper the DC voltages to the LNA power plug are usually small in diameter, you can pull the LNA powering plug off of the LNA and check the voltage to the LNA at the cable end plug and find the voltage at or near normal. Then you can go back to the LNA power supply and find it reads normal there also (i.e. 13.8 VDC on a 13.8 VDC supply). What you **cannot check**, easily, is the voltage being delivered to the LNA portion of the plug when the power supply is 'under LNA load.' That voltage, with the LNA connected, may be down a couple of volts. The voltage 'drop,' under load, can become substantial if there is a corrosive section in the powering line at the plug or just ahead of it. And you see that drop only when the LNA is connected, and there is a load on the line.

Much of the field problem with this type of corrosion problem is down inside of the powering plug that connects to the LNA proper. Moisture works its way down inside what many (falsely) assume is a grommet-sealed moisture-proof plug.

In a conventional (50 + dB gain) LNA, the first segments of the LNA to develop operational problems with a voltage drop are the critical first stages of the LNA. After the loss of first-stage(s) noise figure (and gain), caused by a lowered operating voltage through the regulators to the first couple of stages the so-called 'bulk gain' stages have problems next. Here you can easily see that you have a problem, something you can hang your hat on. As the bulk gain stages go down, the signal level meter on your meter reflects less signal from the dish plus LNA. A change of a few numbers on the receiver relative signal level meter can be an indication that bulk gain stages have lost some gain. That can also be puzzling since most of us know that we typically have signal voltage to burn with a 50 + dB gain LNA, and a few dB in lost bulk gain should not even be noticeable in picture quality. It is seldom the bulk gain reduction that causes the 'eye-visible' loss in picture quality; unless the bulk gain loss is independent of a lower DC supply voltage, and is associated with a marginal system. More often, the lower relative signal level meter reading is a symptom of a larger problem; a drop in supply voltage to the LNA.

Over on the coaxial cable side (which may be the 'same side' if you are duplex powering the LNA up the feedline), an even smaller amount of corrosion can drop signal voltage from the LNA to the receiver (or down converter) proper. In the popular remote down converter configuration, where you exit the LNA with a short length of flexible cable and plug into the remote down converter, you have two chances for problems.

- 1) The interconnecting cable picks up corrosion;
- 2) LNA powering, if it passes 'through' the downconverter, can experience a voltage drop caused by the corrosion on a contact or splice.

Isolating the problem can be a real tough process. The LNA **could** be bad; it **could** be a voltage problem; it **could** be the down converter proper, or any of the many cables that are outside. Most of the remote down converter units do not do a very good job of sealing moisture out, and as there can be considerable (DC) current present, the risk of electro-chemical electrolysis is high. This risk increases in direct proportion to your location, and the amount of moisture in the air.

Several of the manufacturers who have thought this one out point out that a container that produces heating (the electronics inside and it draws current; the current creates heat which is dissipated in the electronic parts, and which in turn heats up the interior of the container) is a 'plus' since the heated air or environment inside of the container (where all of the circuits are located) will 'drive' moisture laden ambient-temperature air out. A container that allows air inside is not necessarily bad news. A container that breathes 'in' and 'out' is bad

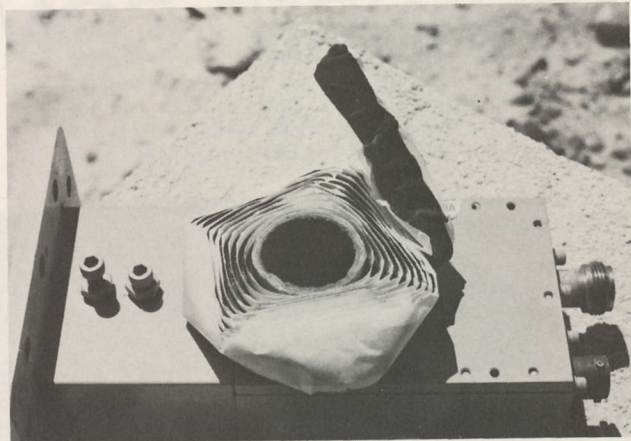

COAX SEAL — is a non contaminating substance that refuses to cure. It comes on 'rolls' up to 50 feet in length, or in smaller packages.

news since cool air is sucked in, where it heats up. This process starts a moisture condensation process working and the moisture can get left behind. **Inside the container.**

If all of this sounds dangerous for the integrity of the microwave electronic circuits, you have a pretty fair picture of the problems associated with sticking any type of electronic circuits outdoors.

PROTECT YOURSELF

The best way to carry DC voltage to an LNA is to get it from the power source to the LNA voltage input connector through a completely protected transmission medium. That says run a continuous piece of cable with no breaks in it, from the connection to the DC power source, to the LNA power connector at the LNA proper. The cable should be designed for use in an outdoor environment.

At the LNA, if the LNA is being rotated by a motor (with the feed connected) to select between polarizations, and/or to allow for polarization shifts as the dish is swung through the geostationary/Clarke orbit belt, you must allow for movement of the LNA powering cable as the LNA turns on its axis. A very stiff cable will not allow for this rotation without placing strain or mechanical stress on the connector/cable junction. A soft, flexible cable is therefore advised although the temptation to select a rugged outdoor cable such as TW12 direct burial cable is great.

Mechanical strain on the LNA power connector is a frequent source of problems for the system installer. Most LNA power connectors are rugged, but they are designed for direct connection of wires in



PROTECTED — DC powering cable has been caulked with bathtub caulk which hardens to a tough encapsulated cover to keep moisture out.

PLAY BALL!

Find all your favorite baseball teams on satellite with WESTSAT's ...

1982 SATELLITE BASEBALL GUIDE

... a full listing of over 600 Major League satellite televised baseball games for the full 1982 season.

Catch your favorite teams in action on satellite now with WESTSAT's 1982 SATELLITE BASEBALL GUIDE - AVAILABLE FREE with each subscription to the ... WESTSAT SATELLITE CHANNEL CHART.

... recognized as the most accurate guide to all present and future satellite transponder assignments.

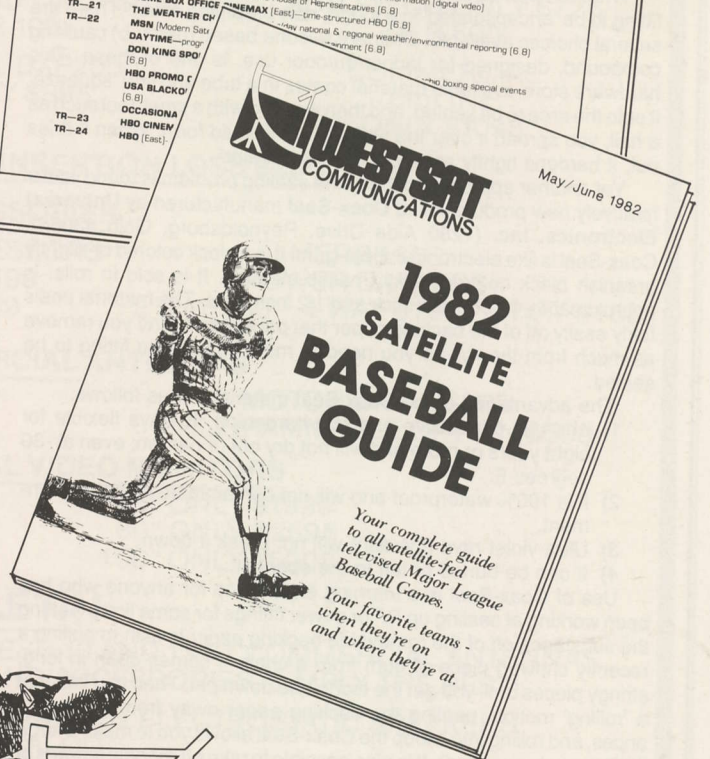
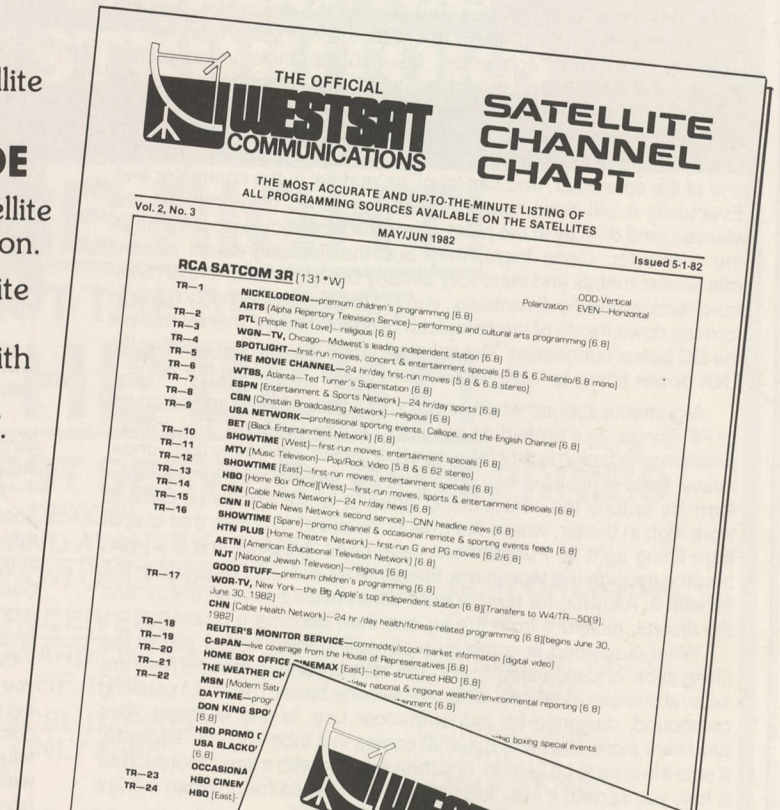
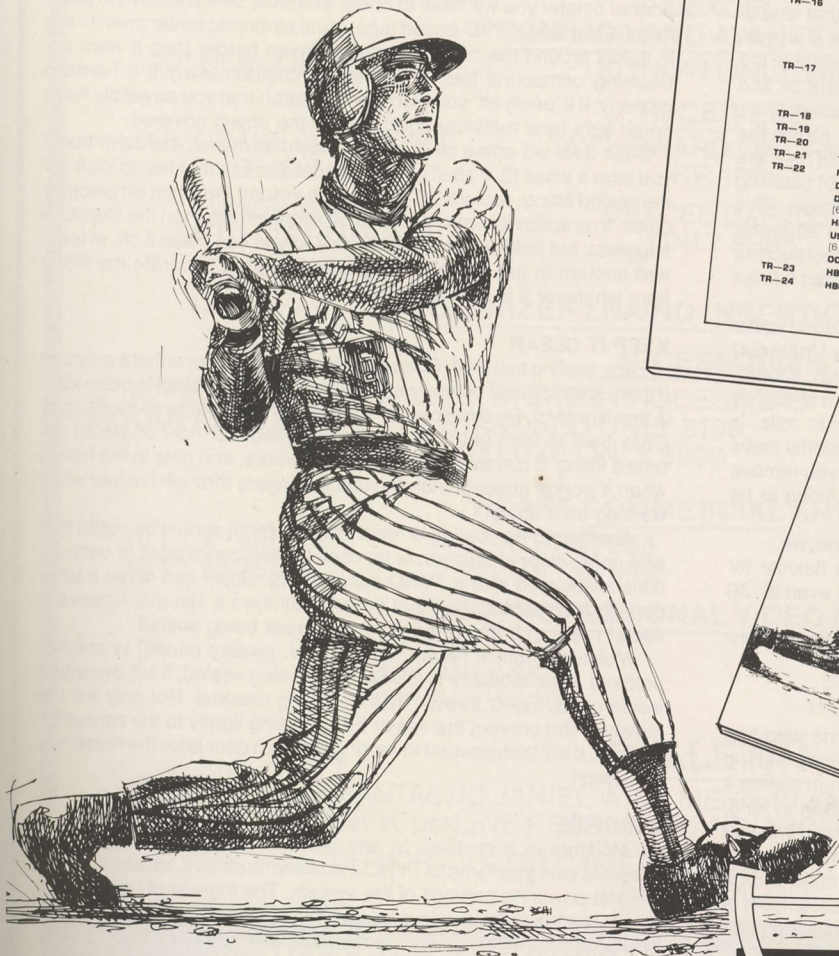

Subscribe today and keep up with whats up.
1 year - 6 issues (updated every other month) :
\$19.00, U.S. (1st class mail)
\$24.00, International (Air Mail) (U.S. Funds Only)

NO WAITING! All subscriptions mailed on same day received.
Payment in full must accompany all orders.

WESTSAT
COMMUNICATIONS

P.O. Box 434 • Pleasanton, CA 94566 • (415) 846-7380

the 20/22 gauge range. A larger gauge wire can be fitted to the connector only through a 'transition' to a smaller gauge wire, and that says a splice. Attempts to wire directly to the connector with large gauge wire results in cramming too large an object into too small a space. When the whole device then moves on a regular (LNA rotation) basis, the result is some give and take at the connector, and the connection either breaks loose or shorts the two sides together.

Most LNA power connectors have rubber moisture protection jackets, and sleeves and grommets, which are designed to keep the moisture out. Unfortunately, the LNA power connector sits in an inclined position, with the wire-end of the connector pointing 'up' towards the sky at an angle. Rain therefore falls down into the wire-end of the connector, and can 'pool' or 'puddle' in the connector end. Eventually it will drain down through the series of grommets, and sleeves, and directly to the point where the wires solder to the pins on the connector. Once there, they add the final ingredient needed (dis-similar metals and electricity already being present) to start electro-chemical activity. Eventually, you will have a white, chalky material forming down inside of the connector. And eventually, this will 'rot' out the DC power connection. The solution, since you can't re-position the LNA power fitting to 'hang down' (and drain), is to seal the fitting.

Arguments abound whether you should use plastic tape on power or RF fittings, as a protection against moisture seepage. The primary problem with taping is that tape must be 'pulled' extremely tight, under heavy hand-pressure, to insure that the tape closely (i.e. snugly) form-fits around the object being taped. It is not always possible to work high in the air, where the LNA is installed, to create that kind of form fitting tight fit. Furthermore, tape does 'breathe' and if air can breathe through the tape joints, the same air will carry moisture in the air with it. Allowing for temperature differentials between the air and the fittings, moisture from the air can then become a problem.

What is needed is some type of sealing system that allows the fitting to be 'encapsulated' in a tough, non-breathing cover. There are several choices available. Ordinary silicone based (bathtub) caulking compound, designed for indoor/outdoor use, is one of these. This hardware store-available material comes in a tube and you 'squeeze' it onto the area to be sealed, and then working with a small tool such as a nail, you spread it over the fitting in semi-liquid form. When it dries out, it hardens tightly around the object sealed.

Yet another approach to the same sealing problem is found with a relatively new product called **Coax-Seal** manufactured by **Universal Electronics, Inc.** (1280 Aida Drive, Reynoldsburg, Ohio 43068). Coax-Seal is like electronic bubble-gum. It is a black colored or slightly greenish black colored tacky, mastic material. It is sold in rolls, is approximately 1/16th inch thick and 1/2 inch wide. The material peels fairly easily off of the backing paper that packages it, and you remove as much from the roll as you need to mold around the fitting to be sealed.

The advantages of the Coax-Seal material are as follows:

- 1) It is non-conductive and non-hardening. It stays flexible for eight years or more and will not dry out or harden; even at -30 degrees F.
- 2) It is 100% waterproof and will not contaminate in the environment.
- 3) Ultra-violet rays (the sun) will not break it down.
- 4) It can be buried or left in the open air.

Use of Coax-Seal is a learning experience for anyone who has been working at sealing up RF or power fittings for some time. Getting the substance off of the removable backing paper is akin to pulling a recently chewed piece of gum from a chair. It comes apart in long, stringy pieces until you get the technique down pat. Then you find that a 'rolling' motion, peeling the backing paper away from the substances, and rolling into a loop the Coax-Seal allows you to make a large 'ball' (loosely wrapped). It is also possible to take off modest lengths of up to 6 inches or so at a whack, as 'surgical sections' which can be directly wrapped around the fitting.

One of the chief advantages of Coax-Seal is that it will adhere to virtually any surface material known, including the PVC jackets on cables which often are so slick that outdoor rated PVC tape only adheres when placed under intense hand ('stretch') pressure. Since getting that kind of pressure at the top of a ladder, while working at an angle with the rear of the LNA is all but impossible, this means you can



COAX SEAL applied — it feels like damp putty and molds and conforms to the fitting being 'wrapped.'

gently mold the Coax-Seal around the fitting to insure that it fills all of the cracks and crevices of the fitting.

Another advantage of Coax-Seal is that no fitting is there forever. Sooner or later you will have to break whatever seal you have in place to get at the fitting. PVC-based tape, hand stretched under pressure to fit tightly around the object, comes off even harder than it went on. Caulking compound has to be literally chipped away if it hardens properly; if it 'peels off' you discover (too late!) that you never did have an air tight (and moisture tight) seal of the object covered.

Coax-Seal will come off. The manufacturer makes the claim that if you form a small (3/4") ball of the material and use that ball to 'pick up' the sealed fitting, you will 'lift' the sealing around the fitting off piece by piece. In practice this may prove to be a longer task than the literature suggests, but field use proves that indeed you can clean it off, at least well enough to get at the fitting proper and then separate the fitting from whatever it is connected to.

KEEP IT CLEAN

Any sealing material (Coax-Seal included) will not adhere properly if there is any type of contaminating solution on the object to be sealed. A thin film of oil, for example, on a fitting will cause tape or caulking or Coax-Seal to form but not seal. You may wonder how oil would get onto a fitting. It comes off the hands of workers, and gets to the hands when a worker absentmindedly rubs his fingers through his hair while working on a fitting!

Another no-no coating is rosin from solder (it should be noted that acid core solder should never be used for any connectors or connections associated with a TVRO installation!). Rosin can leave a powdery residue behind, and that powder will form a film that keeps the sealer medium from adhering to the object being sealed.

Moisture (from a recent rain shower, sweaty hands) is another problem. If the moisture is on the object being sealed, it will be sealed inside of the object forever by the sealing material. Not only will the moisture film prevent the sealer from forming tightly to the connector surface, it will also amount to locking the barn door after the horse has run away!

SYNOPSIS

Moisture is a problem to any outdoor electronic installation. It presents twin problems to TVRO installations since it attacks both the RF and powering portions of the system. The ingress of moisture on the powering section can confuse the system diagnostician since powering problems caused by moisture can appear to be RF-only problems.

Moisture presence, however, can be readily recognized with a careful inspection of the connectors or connections. In RF cable connections, a dulling of normally bright surfaces is an indication of trouble. In RF or power cables (with DC present on the RF cable), any white or greenish powdery substance is a sure sign of problems.



**WHOLESALE
DISTRIBUTORS**

YOU ARE RIGHT!
WE ARE NOT THE BIGGEST
JUST THE BEST!

BEST PRODUCTS • BEST SERVICE • BEST PRICES

**DEXCEL
AMPLICA AND AVANTEK LNA'S**

120° NOW ONLY \$400

110° NOW ONLY \$450

100° NOW ONLY \$500

RECEIVERS

R.L. DRAKE ONLY \$725
ESR 24

TAY HOWARD ONLY \$595
HR 100

AUTO-TECH ONLY \$725
GLR 500

WASHBURN
EARTH TERMINAL
ONLY \$1595

DEXCEL DXP2000
ONLY \$895

COMMERCIAL
proLINE
ONLY \$1095

POLARIZER-LNA-NO INSERTION LOSS \$200

ACCESSORIES

PROFESSIONAL
MODULATOR \$100

proLINE STEREO PROCESSORS
STANDARD ONLY \$199
DELUXE ONLY \$299

MERRIMAC
POWER DIVIDERS
2 WAY \$50 4 WAY \$100 8 WAY \$150

VIDARE COMMERCIAL ANTENNAS

10 FT \$ 995
13 FT \$1395

16 FT \$2995
20 FT \$4995

MOTOR DRIVE \$200
PROGRAMMABLE OPTION \$500

NEC PROFESSIONAL VIDEO MONITORS

12" ONLY \$400
19" ONLY \$500
25" ONLY \$700

45" ONLY \$1995
60" ONLY \$2595
100" ONLY \$6900

BULLETIN

JUST ARRIVED! FANTASTIC JANIEL WIRE MESH 10 AND 13 FT COMMERCIAL ANTENNAS
AND OUR NEW proLINE RECEIVERS AND ACCESSORIES. SIMPLY THE BEST!

MUCH MORE VCR, COLOR CAMERAS, JANSZEN ELECTROSTATIC SPEAKERS
FREE CATALOG

JV ELECTRONICS • WHOLESALE DISTRIBUTORS

41 CANAL STREET, BOX D208

LANDING, NJ 07850 • TEL. 201-347-3206

UPDATE ON NON-DOMSAT BIRDS

DATA BEGETS DATA

The April issue of **CSD** carried a front cover report put together by that intrepid satellite dish ambassador, Bob Behar. Behar hauled a twenty foot antenna, a pile of receivers and 85 degree LNA capability to Cameroon, in Africa. There, as the April issue reported, he brought the first live television reception to a nation of more than 8 million people. Apparently he tickled a national 'nerve'; subsequent reports tell us that Cameroon is engaging COMSAT to design an Intelsat inter-connected national television system.

Behar was on-the-air in Cameroon barely two days. His observations, reported here, were confined to those two days and he was hampered by local viewers who wanted to absorb program content more than program quantity. His report has triggered a lengthy out-pouring of fresh data from England's Steve Birkill, the father of the PLL detector system.

Birkill has been watching, and recording, Atlantic path Intelsat, Ghorizont and some Indian Ocean bird activities since the mid 70's. His equipment is, by North American standards, borderline. An 8 foot dish, and 120 degree LNA are not what you would probably consider adequate to go searching for Intelsat on Global beam patterns. But Birkill is perhaps the finest 4 GHz TVRO receiver designer in the world today, and what Steve lacks in antenna and LNA capability he works steadily to make up with receiver designs that are probably generations ahead of the best in North America.

Extracts from his report follows.

Bob Behar reported on the reception in Cameroon of the (American dial) TR9 channel from Ghorizont at 14 west. The same transponder is seen in the eastern portions of North America, throughout South America, as well as Europe. It is probably the closest thing to a 'super-power' international 'super-channel' operating in the world today. Birkill comments on the reception, and the operational patterns of this transponder and bird.

"This transponder, inspite of its wide coverage, carries Moscow TV for a relatively small proportion of the total time; typically around the '9 O'Clock Evening News' when it joins the Moscow-1 Programme. Outside of these times it carries a merry assortment of occasional Intersputnik/Intervision traffic, with the UPITN news exchange ('direct satellite service from London') at 1300 GMT, a compilation of news clips assembled for the UPITN group by Independent Television News (London). This package is sent out from London via Intelsat and via the European terrestrial network. The Soviets take the terrestrial feed, convert it to SECAM color (it originates in PAL) and send it out on the 3875 MHz Atlantic 'Global' beam to Intersputnik affiliates. Immediately after UPITN finishes their feed, Intervision conducts its own news exchange coordinated from IVN Prague; also on TR9. Each member in turn uplinks with its own news clips. The uplink sequence is usually Moscow, Warsaw, Prague, Bratislava, Budapest, Sofia, Bucharest, Berlin, and Habana. The Cuban transmission is typically 625 line SECAM to IVN, but it reverts to 525 line NTSC at the end of the feed. The channel then, typically, reverts to the (type) 0167 test card until a few minutes before Vremya (news) at 1700 GMT.

During the evening, here in the UK, the channel drops into typi-

cally East German TV from around 1800 GMT (that's 2 PM in the eastern USA) and that holds until their shut down at 2100 GMT. At that point, either they revert back to the 0167 test card, or all hell breaks loose!"

What type of 'hell,' we wondered of Birkill.

"We often see the Cuban TV in the later evening period, but it is not there all of the time. I have seen some very strange feeds out of Cuba, including **Close Encounters** which had been subtitled in Spanish, and **Star Wars** (!) actually dubbed into Spanish."

The presence of Star Wars, dubbed into Spanish, brings up a related incident. That movie has not yet been released to non-theater showing in the US and the owners claim they have no intention of doing so. 'Bootleg' copies of the film, on tape, are not difficult to come by however. Recently Cuban Premier Fidel Castro has been interviewed on CNN where he made the 'boast' that he really enjoys US satellite programming, with a 50 foot (!) dish in front of his residence. In another report, the folks at MPAA have charged that Cuba is pirating US movies, in the black market and off of satellite, packaging them and then reselling them in South America. MPAA labeled Cuba has the number one copyright pirate in the world. Birkill's observation of **Star Wars**, dubbed into Spanish (something of a project in itself), on Ghorizont, would appear to confirm that report. What else has Birkill noticed with the Cuban feed?

"The Soviets have been observed taking the Cuban feed at 3875, converting the NTSC standards to SECAM, and then re-broadcasting that feed in SECAM color on the next (Ghorizont) channel down (3825 MHz), for Europe. I don't think this is for broadcasting purposes, probably it is simply for the entertainment of the Soviet night shift!"

Perhaps Steve, but there is another possibility. The Cubans have provided thousands of troops ("advisors" as they are called) to a number of African nations. Is it not more likely that the Cuban television, via Ghorizont, serves two purposes; relay in the western hemisphere, on 3875 MHz, for various Cuban-influenced nations, and then relayed again, after SECAM conversion, to 3825 to Cuban troops in Africa? The re-conversion to SECAM, for Africa, would fit since NTSC receivers there would be in short supply, but the Soviets could supply SECAM receivers quite easily.

Birkill continues on his 'hypothesis' that the Soviets do the 3875 to 3825 NTSC to SECAM conversion "just for the fun and entertainment of the Soviet Ghorizont technicians."

"Ghorizont was recently seen in this time period showing a run of Bruce Lee martial arts movies, clearly off of video cassette. One of these was subtitled in Dutch, but that only indicates where the tapes may be coming from. They also seem to like to transmit pop music, with a preference for the BBC's **Top Of The Pops** and Radio Bremen's **Musik Laden**, in 625 PAL. These programs are played

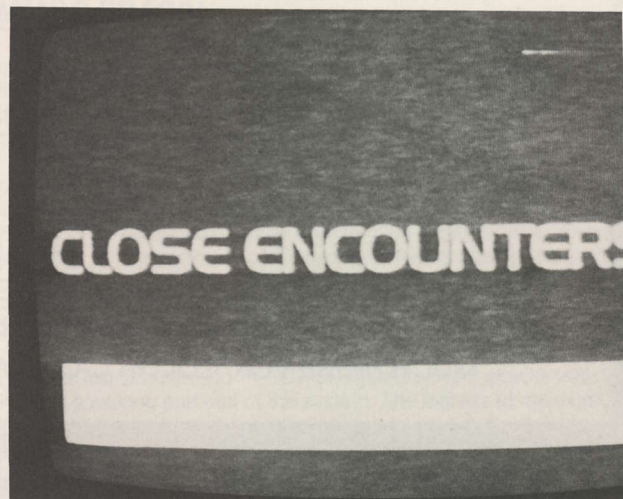

STOLEN FLICK? Close Encounters (**Encuentro Cercano**) transmitted by Moscow uplink, after reconversion of Cuban uplink from NTSC to PAL. Is Fidel Castro sending us a message? Should we send Jack Valenti to 'negotiate' with Fidel???

the STARBEAMTM

RUGGED WIND RESISTANT ANTENNA

FOR GROUND OR ROOF MOUNT.

- ★ Available In: 3.6 Meter & 4.9 Meter
- ★ Motorized Polar Sweep
- ★ LNA Weather Shroud and Mount
- ★ LNA Rotor, Quick Change
- ★ Complete Systems Available
- ★ PROMPT DELIVERY

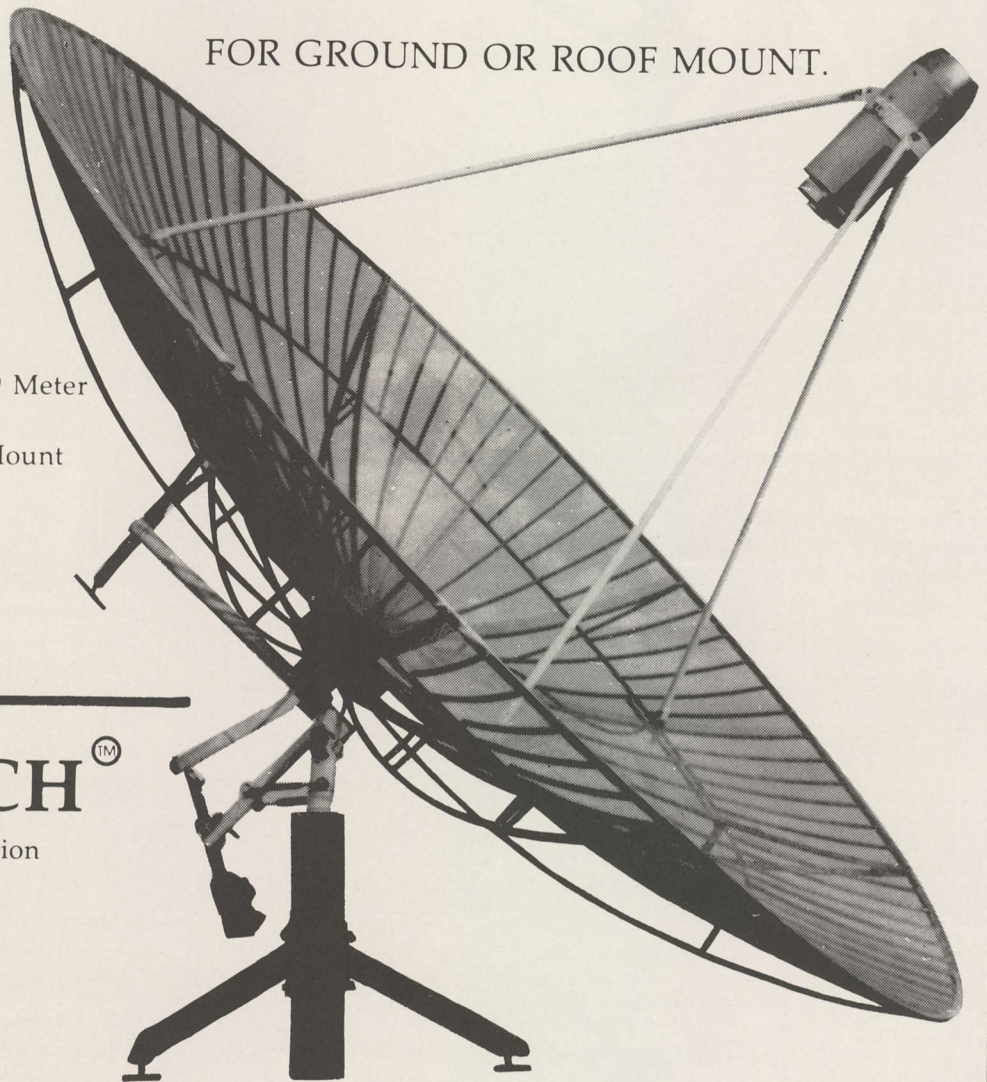

STARSEARCHTM

- ★ Computerized Satellite Selection
- ★ Digital Read-Out
- ★ Back-Up Memory
- ★ Over 900 Satellite Positions
- ★ Solid State Positioning
- ★ Powerful Servo Motor

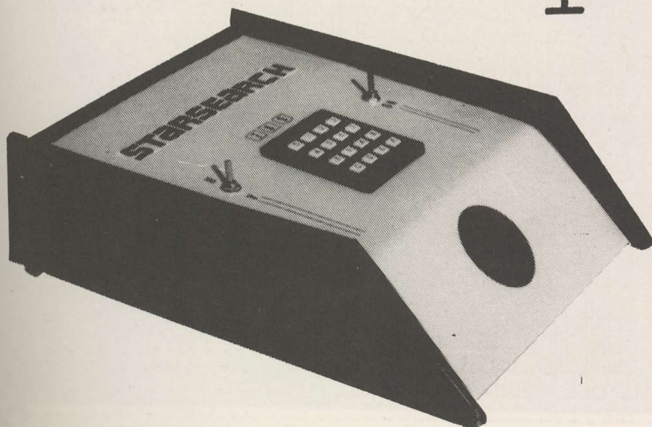

- ★ Two Antenna Control Systems to fit most Antennas

ERVACK SYSTEMS, INC.
2608 Losee Rd., Suite C
North Las Vegas, NV 89030

★ Full Dealer Program Available
1-702-642-7921

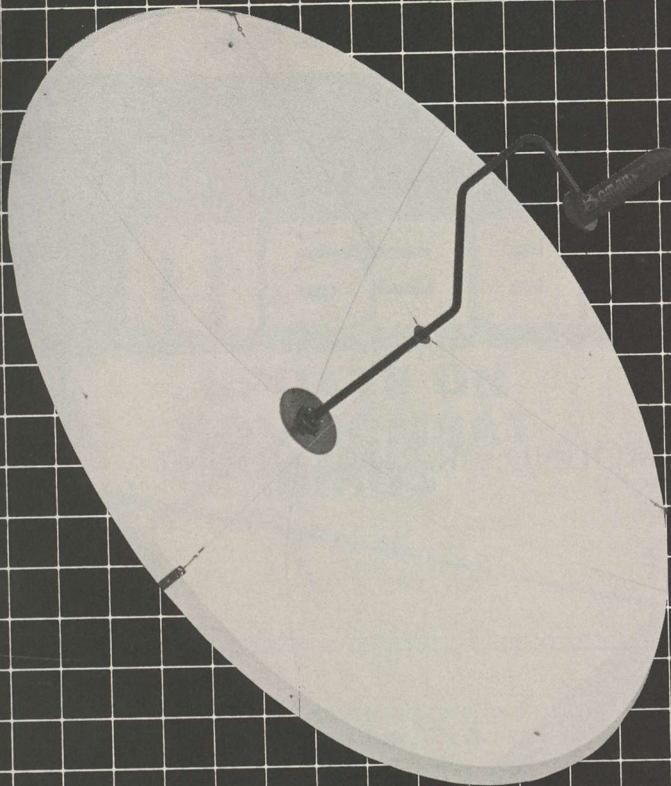

The **Boman SA-3300** is a 4-section TUNABLE fiberglass parabolic antenna. **Features:** ■ 3.3 meters of quality reception ■ fiberglass construction for long life ■ light beige finish for minimal heat transfer ■ 4-section design for easy 2-man installation ■ wt: 180 lbs.

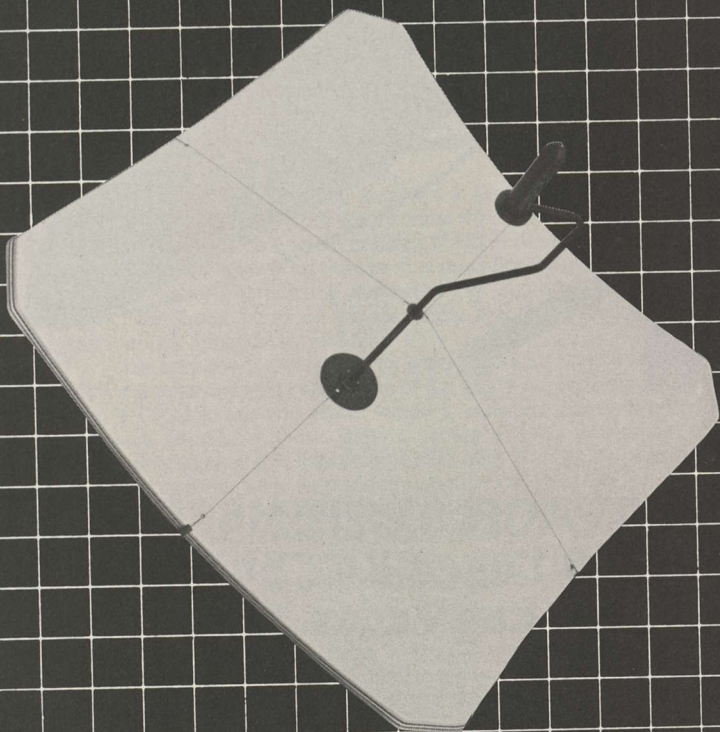

**YOUR
CHOICE!**
\$399⁵⁰
(DISTRIBUTOR PRICE)

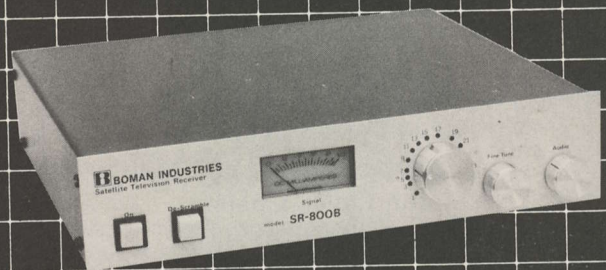

The **Boman SR-800B** Satellite Receiver uses advanced technology to provide high quality reception at a very affordable price. **Features:** ■ 24 channel capability ■ 6 audio channels ■ fine tuning control ■ AFC ■ illuminated signal strength meter ■ attractive design fits any decor

The **Boman SA-3650** is a one piece 9' square Parabolic Antenna. **Features:** ■ fiberglass construction for durability ■ unique design delivers 3.3 meters of quality reception ■ center mast location for quick & easy installation ■ heavy duty rear support structure ■ wt: 160 lbs.



BOMAN INDUSTRIES
SATELLITE PRODUCTS DIVISION
9300 HALL RD., DOWNEY, CA 90241

Toll Free Numbers:
Inside CA.: (800) 352-2552
Outside CA.: (800) 421-2533



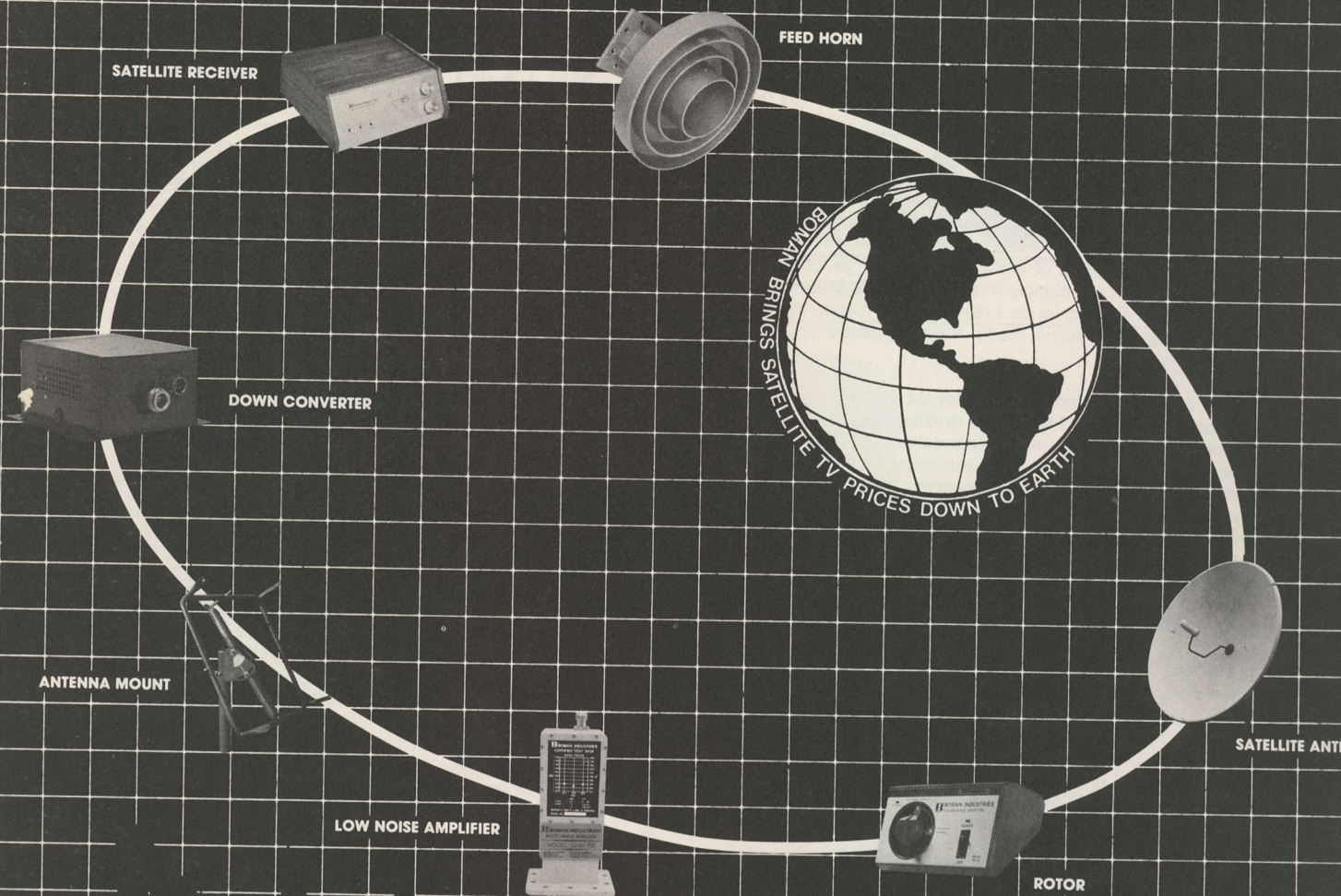

The **BOMAN SAT-VISION KR-250** Rotor Kit

FEATURES:

- "Whisper-quiet" design for silent operation
- Color-coded polarity dial with operation light
- 100° rotation field to prevent cable snarl
- Specifically designed for Satellite TV use.

\$59⁵⁰ DIST. PRICE



The **BOMAN SA-3000** is a **THERMO-COMPRESSION MOLDED** Satellite Antenna... **NO MORE GRIEF!**

FEATURES:

- 3.0 meters dia.
- 8 interlocking fiberglass sections for quick, precise assembly
- Unique design allows for superior stress resistance to withstand extreme environmental changes... **NO MORE GRIEF!**

\$499⁵⁰
DIST. PRICE

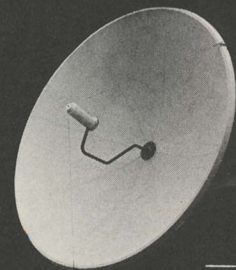

Please send me information

Name: _____
 Title: _____
 Company: _____
 Address: _____
 Phone # _____

**BE SURE AND VISIT OUR BOOTH
 AT THE CES SHOW . . . JUNE 6-9
 BOOTH #4018 . . . SEE YOU THERE!**



directly off of cassette tape, often with one show directly following another after (pregnant) pauses for tape stopping and rewinding. They also have a passion for **Bugs Bunny** and brief segments of 'soft porn' movies. Much of this enigmatic material is accompanied, on the bird, by a group of eight electronically generated 'question marks' inserted in a rectangle in the lower right corner. All of this is very un-Soviet. But, as far as I can judge by monitoring the start to finish of such clandestine feeds, they do indeed originate at the Moscow uplink."

The actual Ghorizont uplink for 14 west is reported to be located at Dubna, 150 kilometers north of Moscow. This particular uplink system was built to accommodate what the Russians hoped would be their propaganda coup of 1980; the 'Olympic Games' of that year, held in Moscow. Their uplink antenna is reported to be 12 meters in size while a trio of nearby Intelsat uplink/downlink antennas are 32 meters in size.

Birkill continues. "There have been 'deeper' mysteries associated with the Ghorizont observations. One evening a European pop music show was being transmitted on video, while on the audio side we had an American football commentary from CBS-TV. This was apparently live, with appropriate breaks for commercials (which were not heard on the feed, indicating it was coming from a stadium to network feed). I have no idea where they got their hands on a live feed from US (CBS) television; I checked all of the Intelsats I can see from here (which includes those used to transmit between North America and Europe, across the Atlantic) and could find no trace of the CBS TV game on Intelsat. Then very recently, on what has become the 'Bruce Lee Evening,' while they were running short clips from the BBC "A Song For Europe" programme which had been transmitted here in the UK two weeks prior, they kept cutting back and forth to a live (simultaneous) program on BBC-1. I cannot imagine where they were getting the BBC-1 feed from, as it was not the type of program the BBC would be transmitting via bird, to anywhere."

The CBS football feed may well have come around the world from the 'opposite direction,' i.e. via the Pacific and then Indian Ocean birds. With three Intelsat dishes at the Dubna facility, where both Ghorizont uplinks and Intelsat links are maintained, it is not difficult to envision that a technician sits before a bank of monitors feeding in programs from a wide variety of sources. With instant, electronic standards conversion possible at the push of a button, they may well have the most elaborate "anything in/anything out" system in the world today. Certainly the gear originally supplied by American networks for Olympic coverage, and then never retrieved after the coverage failed, would make a good start on such a super installation.

Birkill moves off of the Ghorizont transponder 9 activity to comment on Behar's observations regarding the full use of that bird.

"Here in the UK, the transponders in service other than 9 are far

stronger than the TR9 service. I would expect them, however, to be similar to Intelsat EIRPs in the Cameroon. The main one for Europe is TR1, or 3675 MHz (*slightly below the DOMSAT channel 1; editor*). This carrier has a distinctive, wide, slow dispersal rate and this one is **full time** Soviet television. This is on a spot beam to Europe, and was starting to look rather sick by mid-March. The signal drop was in the vicinity of 6 dB from the first operations some two years ago. On March 15, the Russians launched Ghorizont 5. The Soviets had not released a geostationary/Clarke orbit position for Ghorizont 5 but suddenly on March 26th the TR1 signal level jumped up between 5 and 8 dB. The signal level here was so strong after this change that I could actually view the picture by connecting an LNA to a 12 inch 'square horn' and point it out the window! Even with the horn off the LNA, and just the open LNA mouth directed at the satellite position, I could detect traces of the signal on my spectrum analyzer. I now estimate the 3675 MHz signal to have an EIRP of at least 41 dBW here in the UK."

Soviet data regarding the use of Ghorizont 5 conflicts with the Birkill observation. Yet there may be more accuracy in Steve's observations than one finds in the official Soviet data released. According to the Soviet spokesman, a Ghorizont bird is equipped with a single 40 watt transponder (let's assume this is the transponder 9, 'Global' pattern transponder) and five 15 watt transponders. The Soviets label locations and then with prodding may or may not tell which bird is actually 'on station' at that location, at the moment. Officially . . .

- 1) Stasjonar 4/a bird located at 14 west.
- 2) Stasjonar 5/a bird located at 53 east.
- 3) Stasjonar 6/a bird located at 90 east.
- 4) Stasjonar 7/a bird located at 140 east.
- 5) Stasjonar 8/a bird located at 25 west.
- 6) Stasjonar 9/a bird located at 45 east.
- 7) Stasjonar 10/a bird located at 170 west.
- 8) Stasjonar 15/a bird located at 130 east.

However, Ghorizont family birds are **not** assigned to all of these locations at the present time, and in many cases are not planned for location there. We all know about the Ghorizont bird located at 14 west. The specific Ghorizont bird there may not be the same this year as next. The Soviet's admit that their geostationary birds have a shorter life span than our domestic, or, Intelsat birds. A two to three year life span is considered 'normal' by the Soviets. The Soviets are trading higher power per transponder/per bird for lifetime, preferring to be stronger for shorter operational periods of time. Now, what about the mystery of Steve's observations for March 26th?

The Soviets now claim that they have, in fact, been maintaining not one, but **two** Ghorizont birds at 14 west. They also claim that during March they moved one of the two birds there to a location of 90 east (Stasjonar 6 location). They also claim that their March 15th launch of Ghorizont 5 was to 53 east, where they replaced 'one of the existing birds there.' One trade press report noted that the Russians

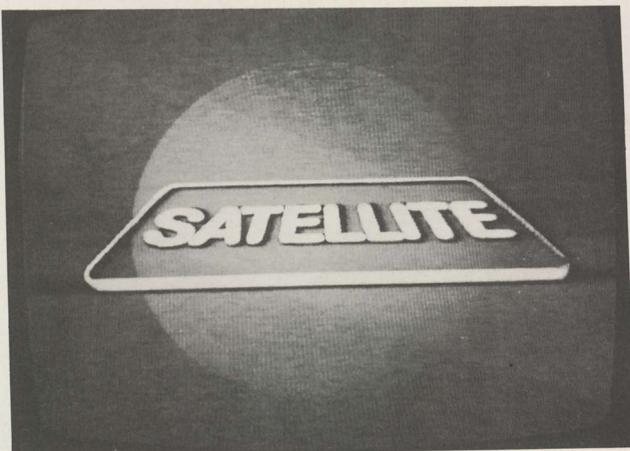

BIRKILL reception with homebrew 12 GHz terminal package from OTS experimental satellite.



RUSSIAN reception on 3 meter SatFinder dish with Birkill modified 'Entertainer' receiver.

FUTURE VISION®

IVC HOME SATELLITE ENTERTAINMENT



SIMULATED TV PICTURE

AN ENTERTAINMENT TECHNOLOGY BREAKTHROUGH IN HOME SATELLITE VIDEO SYSTEMS.

International Video Communications' superior parabolic dish antenna features a uniquely enclosed Low Noise Amplifier. Completely protected from environmental hazards, the dish and LNA are finished in earth tones of brown and sand. It's truly a design that incorporates space-age practicality with revolutionary good looks! Complete the coupon and we'll send you our full-color brochure on FUTURE

VISION®. Mail coupon to International Video Communications, Inc./4005 Landski Drive/North Little Rock, Arkansas 72118/Or call **TOLL-FREE** (in Continental U.S.) **1-800-643-5427**.



Name _____
Address _____

I'm a (check one): homeowner prospective dealer executive interested in IVC production capabilities.
I'm more interested in FUTURE VISION® options.

L

intend to locate 'an existing Ghorizont' to the Statsionar 7 (140 east) location by mid-summer. How does this check with the Birkill observations?

If the Soviets have been maintaining a pair of birds at 14 west, one of these might be described as being 'moth balled.' The one in service, until the March move, could have had a sick transponder for the TR1 coverage Birkill describes as 'All Soviet TV.' When the Soviets moved that bird to 90 east (assuming that is what they really did), the moth-balled bird then was activated and it had a hotter transponder on TR1; hence the Birkill observation.

Birkill also notes "I observe that the operation from 14 west, after March 26th, has a higher inclination (i.e. is higher in the sky) by about 1/2 degree." Yes Virginia, it is possible to stabilize (after a fashion) a bird higher up than 22,300 miles, but station keeping demands far more thruster fuel use. It may be that the Russians had 'stacked' the moth-balled bird up higher above the one sent onto 90 east, and given a reasonable amount of operational time it will gravitate down to the proper altitude. Which brings us to some brief comments on following figure 8 pattern birds with a polar mount, a problem noted by Behar from Cameroon.

"I am at a loss to explain the sudden disappearance of the Symphonie signal, mentioned by Behar, in Cameroon. There is no question that the Symphonie bird is old, and that it has a minimum amount of north and south station keeping. The bird (there are two there, actually) has an inclination of about 3 degrees and one must track it over a figure 8 pattern (east and west, north and south) through a nominal 24 hour period. The two birds use left hand circular polarization and the EIRP on the TV transponder is approximately 26 dBw in the UK. This is really a hemispheric beam, rather than a spot beam, and there is no accounting for the sudden changes observed by Behar as a function of rapid bird oscillations. If the bird jumped about like that, it would either be in the sea, or half way to the moon, by now!"

That was our gut feeling when Bob Behar reported that observation, Steve. A gradual change, as the bird moved out of boresight, would be understandable. A sudden change, cyclic in nature, suggesting the bird was having attitude control problems, is certainly possible. But such a problem would endure for only a short period of time before ground controllers lost control and the bird vaulted either up or down. We have an alternate suggestion to explain what Behar observed (ruling out terminal intermittents). Is it not possible that the French are switching, for test or operational purposes, between their F1 and F2 birds? And if they are switching, could they not be switching off one bird, going silent for a few seconds, and then switching back on with a second bird (F2)? This would be not unlike the Molniya observations detailed in CSD in the summer of 1980. The French do, by the way, fly both birds as a package, and reports indicate that they have both telephony carriers and the single TV carrier 'up' pretty much all day long.

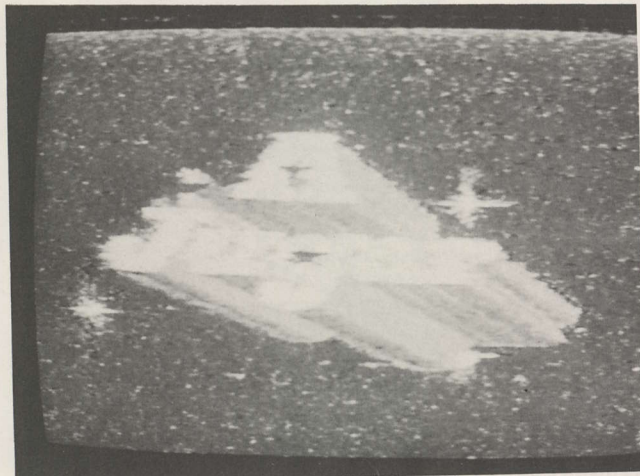

NSTC COLOR (trust us) from Cuba on transponder 9, originating from Cuba, as seen in Sheffield, England by Birkill.

The subject of breaking down the Ghorizont/14 west operation even further is not yet complete, however. Birkill notes "Other than the 3675 (just below American band) and 3875 (TR9) transponders, the next one of interest is the 3825 transponder. I have already commented about finding Cuban TV, converted to 625 SECAM, on this transponder while the Cuban 525 line stuff has been on 3875. This has always been a 'spare channel' and until early April it was sitting for most of the 24 hours per day with the typical type 0167 test card on it. Every now and again one would find a broadcast or news feed, such as the Czech 'Man In Moscow' report being sent from Moscow to Prague for Czech television. Also, on occasion, this transponder might be carrying one of the other Moscow networks for a brief period of time; such as 2-Programma during the daytime or evening, or the far-eastern Vostok morning program (i.e. the Molniya feed which Coop dubbed "Good Morning Siberia" during his Molniya tests in the summer of 1980). Then early in April it went off, and to date has stayed off. Perhaps the transponder failed. Or, the battery support system is getting low and they need to conserve mains voltage. It is beginning to look like the 'dark days' of 1979/1980 when the old Ghorizont 2 bird became a two channel system.

"The only other recent observations I have of this bird is that in March the Russians ran some (apparently) 'digital TV tests' on what would be US channel/transponder 11. This was centered on 3925 MHz, and this is the first time there has been video here since the summer (1980) Olympics. These tests covered a two week period, and nothing has been seen there since."

The present 14 west bird went into service just about two years ago. Based upon the Soviet's own statement, that they had two birds camped there and then in March moved one to 90 east, one cannot be **really** sure which bird is at 14 west, and which one is at 90 east. If we hear of a new Ghorizont launch in the next few months, and the operational pattern changes at 14 west, then (perhaps) we can form a conclusion. For now, be advised that the only television from this bird being seen in Europe at the present time is on the 3675 and 3875 MHz channels, as detailed by Birkill here. The 3675 channel is detectable in North America, the 3875 channel is (as always) the stronger of the services. Several of us have noticed that the tracking on the 14 west bird has become quite difficult, indicating that the bird now operating there (April/May 1982) is having difficulty maintaining its over-equator position. Bob Behar, from the Miami area, continues to provide feeds from the bird for use by one of the major US television networks, and their late afternoon service on this bird has been far stronger than the earlier (in the day) service. The change is daily, in a pattern, and gradual, indicating the change in EIRP towards Florida is caused by bird movement rather than human control or equipment failure. The bird seems to be moving north and south of the equator far more than previously (which to Birkill would appear to be up and down since he is almost due north of the same bird).

MOVING ON TO INTELSAT

One of the first things Behar saw in Cameroon was a view uplinked via WPBT in Miami, and the slide being transmitted was of a beach just miles from his home. Birkill notes "This transmission was being beamed to Thames Television in London. It was an attempt to create an intercontinental general knowledge quiz game, with participants in London, Miami and Sydney (Australia). The major path (2) Intelsat, at 18.5 west (currently Intelsat IVA-F1) carried the US portion of the feed on **Intelsat TR12**, one of its half transponder format video channels, in 525 NTSC format. This is typical of what one sees on this **Global Beam**. Daily, there are feeds of VISNEWS, UPITN; they go westward at 625 line PAL and eastward at 525 line NTSC. There are feeds from EVN Brussels, the Spanish language service out of Madrid (not the same as their leased transponder service), Washington, Argentina, El Salvador and so on.

"I have been trying to interest the world in the Saudi, Sudan, Zaire and Niger services on IVA-F2 located at 21.5 west for several years now. The 'enhanced half-transponder format' of Saudi and Sudan gives the carrier a clout just a few dB below saturation. Intelsat assures us this is a global-coverage beam. However, if my understanding of the A series 'transponder/beam switching system' is correct, these transmissions look very much more like eastern hemispheric coverage to me. Certainly if they were Global, Behar would

"THE WINNING COMBINATION"!

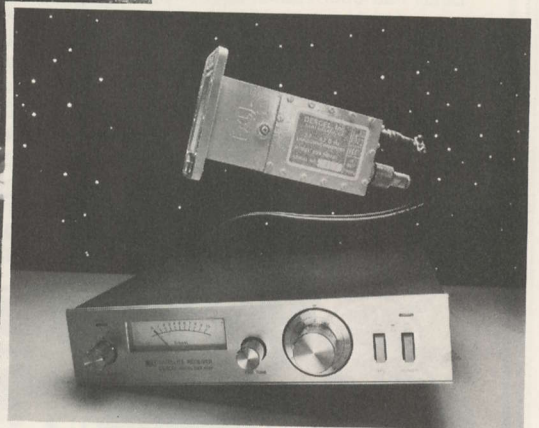

MICRO-SCAN FP-11

- Accurate, high gain 11 ft. diameter parabolic reflector
- Four section fiberglass construction for low shipping costs and ease of assembly
- Tunable parabolic cross sections for maximization of gain
- Extra heavy duty rigid polar mount with 3 ft. x 4 ft. rectangular base structure (no cheap single pole base)
- Adjustable declination
- Electric remote LNA rotor
- Single crank, hand operated satellite finder system
- Easily upgraded to 13ft. diameter with optional EXP-13 upgrade panel set
- Optional electric remote control satellite finder system

Dexcel DXP-1100-01 (120° K) -02 (100° K)

- LNA/Downconverter (LNC) is housed in a one piece, cast sealed unit with integral waveguide feed horn mounting flange. This extremely cost effective and reliable design approach enables your installers to put the system up fast.
- Factory assembled and tested cable sub-assembly for connection of LNC to receiver.
- Front panel mounted signal strength meter
- Continuously tunable audio
- Built-in channel 3/4 modulator
- Dual audio rear panel output jacks
- Full stereo at no additional cost

We distribute the following lines from stock at **extremely** competitive prices

- AMPLICA
- ARUNTA
- AVANTEK
- CATEL
- CHAPARRAL
- COMTECH
- DEXCEL
- GARDINER COMMUNICATIONS
- MICRO-SCAN
- MICROWAVE ASSOCIATES
- PRODELIN
- RCA
- RLC

Complete systems to dealer for less than \$3000.00 quantity/one

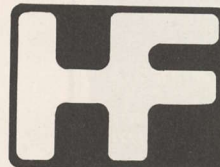

HIGH FRONTIER CORPORATION

2230 E. Indian School Road Phoenix, Az. 85016
(602) 954-6008

SPECIAL THIS MONTH:

COMTECH 650... Call for prices
COMTECH 550... Call for prices

be seeing them in Miami; you would be seeing them on Provo."

We are not sure what 'enhanced half-transponder' means. It sounds like an uneven power distribution between the two halves, backing off one side part way (the video side?) and the opposite side to a greater extent. There have been no indications west of the IVA-F2 bird that it 'sees' in this direction on the Saudi et al transponders.

Steve continues. "I read no indication that Bob cranked his 'big' dish in Cameroon over to the eastern sky, to look at the cluster near 50 east. There are more channels of Russian TV there (Raduga at 35 east, two more channels at Ghorizont at 53 east). But to Cameroon, the Algerian (French speaking) service plus the Nigerian (English speaking) service at 60 east should have been of high interest. Both used the same 'enhanced half-transponder' format and both should have big signals in Cameroon; like Saudi and Sudan.

"On the subject of World Cup Soccer, while it is true that some or perhaps quite a bit will be on the Spain TVE channel beaming to the Canary Islands, virtually every game played will be on Intelsat transponder 12 (TR24 on American receivers), in the half transponder format, on either or both the Atlantic primary bird (24.5 west) or the Atlantic back-up bird (27 west). Both of these are now Intelsat V birds, which while operating on a Global beam, are 3 dB hotter now than the former (and still in use) IV and IVA birds. Plus, I believe you will be seeing some soccer on Ghorizont as well."

Birkill has been 'patiently' waiting for US and UK paperwork to clear so that he may come to the USA where he has accepted employment with the US SatFinder firm. In the interim, he has been active piecing together the first of the private terminals to go into the UK. Using SatFinder 3 meter dishes, 120 LNAs and a much modified Taylor Howard designed receiver (called 'The Entertainer'), Birkill reports very high quality pictures are being demonstrated, and sold, to the first of the UK buyers. On receiver modifications, Birkill notes "While the Russian channel to channel center spacing is on the order of 50 MHz (US is 40 MHz), it appears to me that virtually all of their modulation products can be adequately recovered with a 30 MHz wide IF. I have established a modification package for the Tay Howard



YOU WON'T BELIEVE THIS BUT . . . this is one of the Keith Anderson receivers developed and sold to SatFinder last summer before the Omaha SPTS show. Birkill has one in the UK, and he has modified it for Ghorizont reception. That's the Birkill 8 foot Andrew dish, out of focus in the background. The cardboard container, holding the receiver, really did come from a Vodka distributor. Two famous Russian exports in one 'heap'! Yes, that's the famous 0167 Ghorizont (Russian) test card on the screen.

designed receivers which includes modifying the demod (a fine tweaking applied to the tracking range of the divide by 2,564 demod system), modifying the AFC (to handle the 'super dispersal' employed by the Russians), modifying the de-emphasis network for the 625 line video, retuning the audio demods for the 7.0 and 7.5 MHz audio sub-carriers, and also modifying the audio de-emphasis network for the Russian pre-emphasis.

"I think there may be some mis-understanding on the importance of the video de-emphasis networks. Actually, with a 525 line de-emphasis receiver, the effect on a Soviet 625 line picture is a slight smearing, medium term, noticeable in the center blocks on the 0167 test card, but hardly visible on the average picture. Any other distortion people are reporting is due to some other cause."

As noted in Coop's Comment in this issue, with the 'discovery' of Ghorizont by the US broadcasters, the use of this bird may change quite radically in the months ahead. What used to be "an interesting experiment in the eastern sky" may in fact become one of the primary satellite services available for world wide news services. Only time will tell, and Steve Birkill has been there for several years now pioneering the effort for all of us.

VHF · UHF

Tunable **SATELLITE** **New Improved**

VIDEO-AUDIO MODULATORS

Micro-Verter II series

EXCELLENT NATIONWIDE DEALER PROGRAM!

- AVAILABLE CH. 2-13 plus LOW UHF.
(Each unit tunable over 2-4 channels.)
- CRISP, HIGH FIDELITY COLOR
- NEW TEMPERATURE STABILIZED AUDIO
SUBCARRIER CIRCUITRY.
- DUAL REGULATED POWER SUPPLY.
- ALSO IN PLUG-IN MODULE FORM
(less power supply).

"Over 17 years of video modulator expertise"

SUG. LIST \$80.00

ATV Research Dial (402) 987-3771

13C - Broadway DAKOTA CITY, NE 68731

AUDIO RECOVERY HOW SCPC WORKS

MORE TO HEAR — Than To See!

Several years ago, when this field was largely populated by elec-

DELTA SATELLITE CENTER

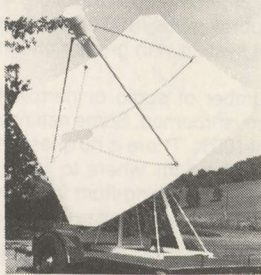

Nova 4/M
Square 9' 2 piece Fiberglass
Antenna with Polar Mount

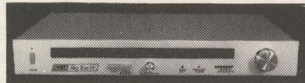

KLM Sky Eye IV
24 Channel Receiver / Down
Converter



Avantek 120°
Low Noise Amplifier

System Price **\$1989***



Drake ESR-24
Digital 24 Channel Satellite
Receiver / Down Converter

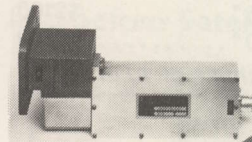

California Amplifier
120° LNA

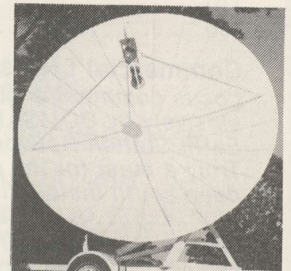

ADM 11'
Aluminum 24 Petal
Antenna with Polar Mount

System Price
\$2396*

* Plus Crating & Shipping

POWER ACTUATOR ADD \$449

Add an Antenna System



KLM Sky Eye IV
24 Channel Receiver / Down
Converter

**California Amplifier 120°
LNA**

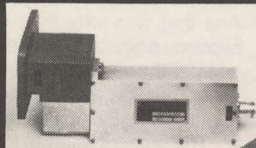

**100' Cable / Connector
Package**

System Price **\$988**

Toll Free Ordering

800-558-5582

In Wisconsin

414-375-1000

DELTA SATELLITE CENTER

1003 Washington St., Dept. 420
Grafton, WI 53024

California Amplifier 120° LNA **\$399**

California Amplifier 110° LNA **\$449**

California Amplifier 100° LNA **\$529**

SATELLITE RECEIVERS

KLM Sky Eye IV	\$ 498
Sat-Tec R2B2	\$ 640
Drake ESR-24	\$ 734
Intersat SRDC-4 Dual / Conversion ...	\$1190

SATELLITE ANTENNAS

Nova 4/M - 9' Square 2 piece	\$1194
ADM 11 - 11' Antenna	\$1245
Hastings 12 PF - 12' Antenna	\$1354
Microsat - 10' Roof Mount Antenna ...	\$1373

AMERICA'S BEST VALUES

LNA's (Microwave Associates)

120°	\$395
110°	\$420
100°	\$475

(single unit prices)

Commercial LNA's

Locus commercial quality LNA's are used exclusively by COMSAT General in the Intelsat Earth Station Network throughout the world. Truly a must for the perfectionist and those deep south installations.

110°	\$525	85°	\$1500
100°	\$675	75°	\$2100
95°	\$800	70°	\$2500

Discount given on the purchase of 10 or more units.

Receivers

KLM Skyeye IV ..	\$525	Washburn	\$1500
Gillespie 7600A ..	\$750	Pinzone 8200 ..	\$2450
Drake	\$735		

Antennas

ADM II	\$1000	Vidare 10'	\$975
Vidare 13'	\$1380	Vidare 16'	\$2900
Vidare 20'	\$4000		

Also please contact us about the new SAVAC 3 meter. It is guaranteed to handle 2° satellite spacing.

Miscellaneous

Power divider 2-way	\$45
Power divider 4-way	\$80
Arunta 312	\$325
Ferrite Isolators (53 DB min)	\$120
Startron eliminators (eliminate the AB switch	\$38
PC modulators (ch 2-3 or 3-4)	\$55
Transifier commercial modulator (any channel)	\$360
Vector 100 Earth Station Remote Control Center	\$550

The finest, most accurate remote control center in the country today. Call us to get the details.

Let's get acquainted.

You'll like our prices and love our service.

Box 824 Fairfield, Iowa 52556

(515) 472-3174

TWX 910-520-2754 (cable code Amer. Tech.)

**AMERICAN
MICROWAVE
TECHNOLOGY**

tronically curious people, there was a considerable passion to find and decipher the then thousands of non video signals being transported via satellite from one point to another. We learned, in CSD through the spring and summer of 1980 for example(*) that you could tune in the live Juneau, Alaska NOAA station with up to the minute Alaska-wide weather conditions, or a trio of Anchorage AM broadcasting stations, or a multitude of ABC/CBS/NBC/Mutual radio network news and sports feeds, plus another batch from AP and UPI. We also learned that there were thousands and thousands of telephone conversations 'up there' on the bird, not to mention dozens of '800 number' toll free call circuits.

We also learned that there were two audio or narrow band formats in use; one stacked audio or data channels approximately 4 KHz apart one right after the other from approximately 100 kHz to as much as 8,000 kHz, and, the other an FM system with greater channel to channel spacing.

In the interim two years the number of audio or narrow band services found on the satellites has mushroomed. Some estimate the growth in two years to be in excess of 100%. There is no question that given the right set of equipment and the right 'where to listen, and when' information, you can listen in on everything from the Moscow to Washington 'hot line,' to 'confidential network executive intercom lines' between New York and Hollywood.

There is also little question that the interception and divulgence of what you hear is pushing Section 605 of the 1934 Communications Act to its very limits. If one traces the historical debate that accompanied the passage of the 1934 'Act,' it becomes evident that the primary concern of that and preceding laws in this area (the first traces back to 1912; and the 1934 law was the last version of three adopted to deal with a problem) was to have legislation in place which would allow the FCC to adopt rules and regulations to guard against 'telephone company employees' using their positions to 'eavesdrop' on private telephone communiques. Somebody, way back in 1912, felt the opportunity for a telephone 'operator' to 'listen' to a private conversation, and having heard some private information then go on the 'open market' to sell such information, was real. The debate leading up to the bill painted scenarios where an operator or other telephone company employee would overhear, accidentally or on purpose, information which then could be 'traded.'

The law framers recognized that it was inevitable that on occasion, in the performance of technical duties, a telephone employee would overhear a conversation. That was the 'interception' element. And that was why they constructed the dual pronged 'test'; interception, and, divulgence. To clarify the divulgence, and to guard against the eavesdropper not trading in the information, but rather taking private, personal advantage of what was heard, the law was expanded to include a second test; 'benefit.'

The present attempt to expand the penalties associated with Section 605 of the 'Act' (the Waxman Bill, the Goldwater Bill) are offered as mere 'strengthening' of the 1934 law, to reflect changes in technology and to specifically add the reception of any non-authorized common carrier signals to the list of those 'protected.' Cable television (not a common carrier) and over the air STV (also not a common carrier) are also being added to the list of 'protected' transmissions.

The audio and data transmissions present on satellite now are actually no different in content than similar services present for decades at lower frequency bands. Radio telephone services, for example, are readily available to anyone with a HF (high frequency) radio capable of tuning in various 'marine bands' that allow ships at sea to communicate through common carrier shore stations, with the mainland terrestrial telephone service. Similar telephone services are found in the VHF band where 'scanner' type radios readily tune. The only real difference between tuning in such 'calls' via a satellite transponder, and doing the same thing on HF or VHF, is the quantity of calls one finds on satellite. There may be a dozen or 15 such 'channels' available to tune in at HF, or VHF. There are thousands on the satellite.

Another 'common' service found on satellite is the network radio feeds, carrying targeted sports, news and music services. ABC Contemporary, ABC Entertainment and other networks carrying news programs and audio features abound on the satellite, since satellite

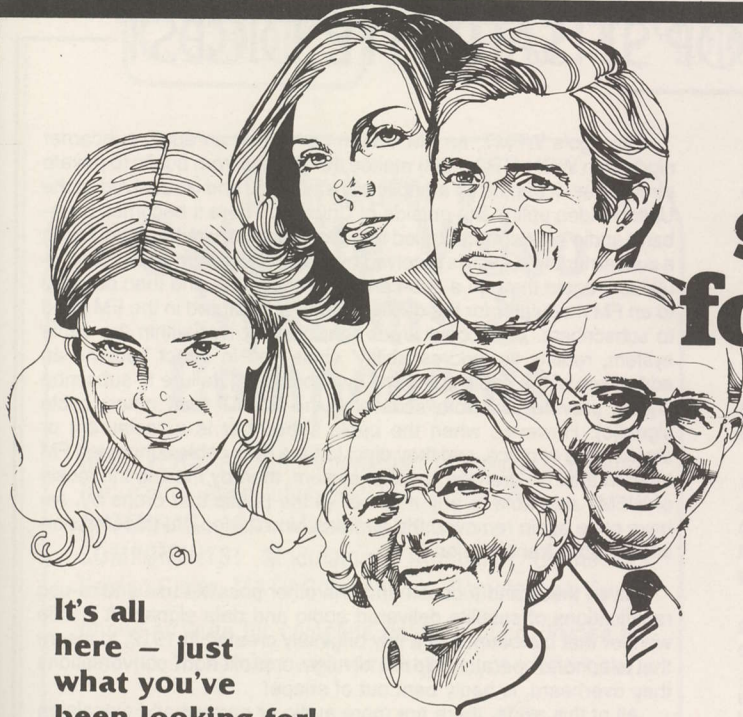

We've got something for everyone.

It's all here – just what you've been looking for!

Satellite TV Week

The only comprehensive, descriptive hourly guide to all your favorite programs and the ones you couldn't find before **Satellite TV Week**

- 10:30 A.M.**
11:30M 12:30C 1:30E 2:30A
- 02 [F3] - Good News America
 - 03 [F3] - INN News
 - 07 [F4] - Transformed
 - 07 [F3] - ESPN's SportsTalk Special: 1982 NFL Draft
 - 09 [W4] - Club de la Television
 - 10 [W4] - Business Analysis
 - 11 [AB] - Mr. Dressup
 - 15 [F3] - News Update
 - 15 [AB] - Femme D'Aujourd Hui
 - 16 [F3] - Tomorrow's Families
 - 17 [F3] - Pitfall
 - 17 [F4] - Jimmy Swaggart
 - 19 [AB] - Regional Program
 - 19 [A2/3] - Just Like Mom
 - 20 [F3] - MOVIE: 'The Late Show' A lady coaxes a crusty private eye out of retirement to find her cat and together they unravel blackmail, mystery and murder. Lily Tomlin, Art Carney, Bill Macy. 1977.
 - 22 [W4] - Susan Noon Show
 - 24 [F3] - MOVIE: 'The Big Red One' A combat veteran leads his battalion of young soldiers into toughening battle. Lee Marvin, Mark Hamill, Robert Carradine. 1980. Rated PG.
 - 03 [F1] - CBS News
 - 23 [F2] - NBC News (Dual A)
 - 21 [W4] - Matinee at the Bijou "Cowboy Commodores"

- 11:00 A.M.**
12:00M 1:00C 2:00E 3:00A
- 01 [A2/3] - Definition
 - 02 [F3] - Good News
 - 03 [F3] - Dick Van Dyke
 - 06 [W4] - Caras y Gestos
 - 07 [F4] - The King Is Coming
 - 07 [A2/3] - One Life to Live
 - 08 [F3] - It's a Great Idea
 - 09 [F3] - Coronation Street
 - 09 [W4] - Catedras Universitarias
 - 10 [W4] - Nyse, Amex Update
 - 11 [AB] - Sesame Street
 - 11 [F2] - Sky...Blue?
 - 12 [F3] - MOVIE: 'I'll Cry Tomorrow' This autobiographical story of Lillian Roth chronicles her decline into alcoholism and her slow journey back to health. Susan Hayward, Richard Conte, Eddie Albert. 1956.
 - 15 [F3] - News Update
 - 16 [F3] - Growing Years
 - 17 [F3] - Bull's Eye
 - 17 [F4] - Our Jewish Roots
 - 19 [AB] - Wok with Yan
 - 19 [A2/3] - Mighty Hercules
 - 22 [F3] - Pertinent Magazine
 - 22 [W4] - Sew Video
 - 03 [F1] - CBS NBA Basketball Playoff (2½ hrs.)
 - 17 [W4] - Big Blue Marble
 - 21 [W4] - Market to Market
 - 23 [F2] - Smurfs
 - 15 [W4] - Last Chance Garage

	First Class	Alaska Hawaii	Canada Mexico
1 year	\$65	\$65	\$75
2 years	\$120	\$120	\$120

Send \$1 for sample copy

FREE Satellite Channel Guide included in every **Satellite TV Week**

CALL
800 358-9997
TOLL FREE
OR
707 725-2476
IN CALIFORNIA



Call for dealer program.

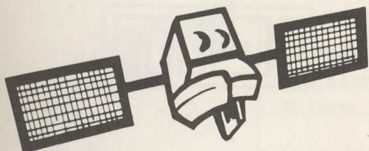

Satellite TV Week

P.O. Box 308 Fortuna, CA 95540

Interconnection is the best system going for wide area interconnection. NPR (National Public Radio) is also found on satellite; sometimes as many as 8 channels of different services. Are these 'private' or are they 'public' transmissions?

All of the network radio feeds are being transmitted for one intent; to allow people to listen to them, via their local (satellite interconnected) AM or FM radio station. Such transmissions are 'private' while they are on the satellite only because they are considered to be in the temporary care of a common carrier; and all common carrier transmissions are regarded as 'private.' The test for a common carrier signal, by the way, is as follows:

"If the transmission is directed at a specific (or multiple-specific) recipient(s), and is not addressed to all of the public at large," it is likely to fall into the general family called common carrier.

There are exceptions to that 'test'; amateur and CB signals, for example. They are 'addressed,' but not common carrier. The 'addressing' occurs via satellite because the sender (transmission station) has a 'list' of authorized receiving points. If you are not on that 'list,' you are not an 'addressee,' and are not authorized to receive the transmission(s).

A feed of the ABC Contemporary Radio Network news service is one of those 'half in/half out' classes. It is 'addressed' from ABC to affiliate stations while it is on the way from ABC to the stations (i.e. while it is on satellite). Once it arrives at the station affiliate(s), it is plugged into the audio board at the station and is retransmitted on AM or FM. Now it loses its 'address' and is available for anyone to tune in and enjoy.

A satellite relay of an Anchorage AM radio station, or of the Juneau (Alaska) NOAA station also changes classes of the transmissions, but in reverse. The station transmits its programs or signals into the air and they are intended for the general public. Reception is merely a matter of having the required receiver type. While it is 'public property,' the signal is received by the satellite uplink folks on a receiver, and the audio from that receiver is patched into a satellite SCPC transmission system. Then the signal is sent out via satellite to one or more 'addressed' receiver locations.

Chicago's WFMT, an FM station carried on an audio subcarrier along with WGN (TR3, F3R) makes the change from public to private three times. It begins as a public transmission, and is received at the United Video uplink site outside of Chicago. There it becomes base-band audio where it is patched into the uplink transmitter modulating a subcarrier of WGN. It is received by the cable system which demodulates it again through a sub-carrier demodulator, and then patched to an FM modulator for the cable system, and carried in the FM band to subscribers. One could argue that the last leg, within the cable system, retains its 'addressability' since you in effect become an addressee of the cable company by subscribing; failure to subscribe should prevent you from accessing the WFMT (and other) cable signal(s). However, when the cable subscriber is a restaurant or stereo store or office, and they elect to tune their cable connected FM tuner to their on-premise speaker system, thereby making the music of WFMT available to any member of the public that drops by, we have once again removed the address, and turned the transmission into a public transmission.

Given these and a dozen and one other possible use and re-use ramifications of satellite delivered audio and data signals, it is little wonder that the bounds of a law originally created in 1912, to insure that telephone operators did not 'divulge' or profit from conversations they overheard, is badly bent out of shape!

All of this aside, there are more audio or narrowband signals on satellite than you can count. We know, we tried. They number in the thousands and they come and go with the same lack of firm scheduling that one notes on Westar 3 'occasional video feeds.' One minute they are there, the next minute they are gone. One day the UPI Sports Desk service is on one transponder in a specific dial spot; the next day it has moved to a new transponder or even a new bird! The whole narrowband picture is so elastic that a person could spend most of his or her waking hours tracking the signals, and still not have a reasonable handle on what is available, from whom, and where.

The Simple System

A very detailed description of how the audio signals are married

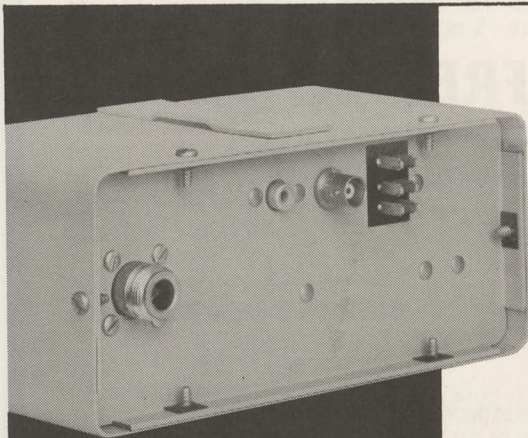

Attention OEM's and TVRO system dealers! Now available in production quantities.

Write or call for quantity pricing.

TVRO DOWN CONVERTER

Input filter for superior performance and interference protection. Built-in DC block. Mounts near LNA in environmental protective case. Converts 3.4-4.2 Ghz signal down to 70 Mhz in two stages. 70 Mhz signal is fed to receiver at lower loss with RG-59 or equivalent. Standard input and output connectors for easy use.

Can be used in multiple installations without need for isolators or other filters.

Specifications: Conversion gain 25 db nominal. Tuning voltage +4-16 VDC nominal. Power requirements 22 to 30 VDC @ 300 ma, (including LNA) Size 3''X4''X7'', weight 1 Lb.

International Crystal Manufacturing Company, Inc.



10 North Lee Oklahoma City OK 73102 (405) 236 3741

Distributor of Satellite Video Systems & Components

RECEIVERS: Avcom, Automation Techniques, Equinox, Microwave Associates, Sat-Tec, Comtech

ANTENNAS: ADM, Miralite, Odom.

COMPONENTS: Modulators, Amphenol Connectors, Belden Cable, MATV Components, Remote Dish Drives.

Phone or write for complete dealer pricing. Please furnish tax ID number when writing on your letterhead.



1005-A East Hwy. 83 — McAllen, Texas 78501
512-682-9954 (512-585-0020 home)

Member: International Satellite Distributors Association

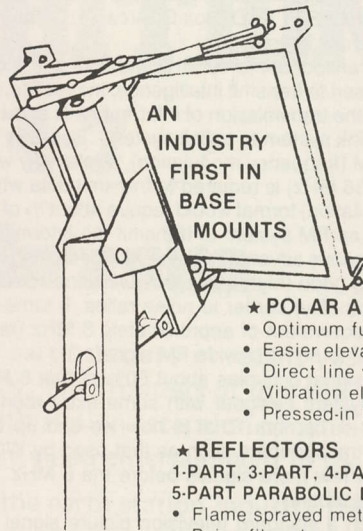

- ★ POLAR ANTENNA MOUNT
 - Optimum fulcrum point
 - Easier elevation
 - Direct line vertical lift
 - Vibration elimination
 - Pressed-in bearings at pivot point

- ★ REFLECTORS
 - 1-PART, 3-PART, 4-PART, 5-PART PARABOLIC DISHES
 - Flame sprayed metal reflective surface
 - Beige fiberglass pebbled parasolar surface

- ★ DEMONSTRATION TRAILERS
 - Concrete weighted and carpeted
 - Tandem axle

DEALER & DISTRIBUTOR INQUIRIES INVITED

SAT-COM MARKETING

ROUTE 1 BOX 268A • KELLYVILLE, OKLA. 74039

(918) 247-6048

(918) 584-5913

Introducing
commercial
quality
Satellite
Television
for your
home.



Now Satellite Technology Services offers you the commercial expertise to engineer the precise satellite television system for your home.

STS stocks a complete line of top quality components at competitive prices with full warranties.

And STS insures you fast delivery with its "ready ship" inventory program.

For more information and our free brochure, call our toll free number.

1-800-325-4058

Satellite Technology Services, Inc.
11684 Lilburn
St. Louis, Missouri 63141

Dealerships may be available in your area.

SATELLITE SYSTEMS OF MONTANA

LNA'S

RECEIVERS

DISHES

LOWEST PRICES

406-782-1444 24 hours a day

into full transponder systems appears in the 'Coop's Satellite Operations Manual,' available from STT (P.O. Box G, Arcadia, Oklahoma 73007). Basically, here is how it works.

A standard domestic transponder is 40 MHz wide. Of this width, 36 MHz can in theory be used to transmit intelligence. In practice, the amount of space used for the transmission of information is closer to 30 MHz (it varies from uplink system to uplink system). Because the transmission method is FM (frequency modulation), a relatively wide transmission band (30 to 36 MHz) is required to transmit data which in the AM (amplitude modulation) format would require about 1/4 of the spectrum space. We use an FM system to transmit the information because it offers us tremendous advantages over AM for dealing with weak signals, and creating good (high quality) signal to noise ratios when we have poor (low quality) carrier to noise ratios. It turns out that we can transmit the equivalent of approximately 8 MHz (megahertz) of AM data in a 32 to 36 MHz wide FM signal.

A standard television signal occupies about 60% of that 8 MHz region. That leaves the system designer with some extra room to slide in some extra data, or carriers. That is how we end up with additional subcarriers on transponders such as that used by WGN; there is room to slide in a few more signals before the 8 MHz 'AM capacity' is used up, at baseband.

The same space which a standard television picture signal occupies can also be used by a large number of narrowband (AM) carriers. Through technology developed through the years by Bell and other telephone companies, it has evolved that you can stack around 1250 narrow band voice or data channels into the space occupied by a single television picture carrier. Having done this, we still have about 40% of the transponder left unused, which simply means we can stack up some more narrowband signals in that remaining 40%; an additional 40% of 1250 or 500 narrowband signals. That's in theory. **In practice**, someplace between 900 and 1200 actual narrowband data (i.e. voice, low baud rate data, etc.) channels can be separately 'programmed' within the space normally occupied by a single TV picture carrier and its one or more attached subcarriers. This means that a transponder taken out of video service

can be divided up approximately 1200 times for 1200 different, unrelated, narrowband services.

The (up to 1200) narrowband signals are married to the satellite uplink transponder in an 'AM' format. That is, each of the voice or data channels is assigned a spot in a 'spectrum' that starts near 100 kHz and ends around 8,000 kHz (8.0 MHz). Each voice or data channel has its own 'carrier,' and each voice or data channel modulates that individual 'carrier' with the assigned voice or data information.

How they do it at the uplink is important only if you have to figure out a way to reverse the process at the downlink terminal. Fortunately for you, somebody has done that for you, and the process of turning a TVRO terminal into an audio and data receiver terminal is not only uncomplicated, it is also not very expensive.

If you have a TVRO terminal, and if your TVRO terminal provides you with a video (baseband) output, you have all of the 'hard work' done to have reception in your home or shop from the thousands of narrowband services available. Remember that the signal transmitted via satellite is FM, and it may occupy up to 36 MHz of spectrum 'space' at 4 GHz. However, by the time you get that signal back and through your LNA and TVRO receiver, you have now re-converted the FM signal (that began as an AM signal at the uplink) **back to AM**. And you have, coming out of your 'video output' (back of) receiver spigot an 'AM band' that stretches from near 0 MHz to at least 4.5 MHz and perhaps all of the way to 8 MHz or so. We'll return to this fine point, shortly.

If you tune your TVRO receiver to a transponder with video on it, what you get out of the video spigot is AM, baseband video; over the frequency range of 0 to someplace around 4.2 (4.5) MHz. Now, if you retune the TVRO receiver to a different transponder, one that does not have video on it, but rather one which has hundreds of stacked, narrowband audio and data channels on it, what you NOW have coming out of your video output spigot is a 'radio spectrum' that starts at around 100 kHz (0.1 MHz) and which ends someplace up there between 4.5 and 8 MHz. You cannot 'hear' these narrowband signals on your TV receiver because the TV receiver is designed to respond

INTEGRATED ELECTRONICS INC.

BOX 204, CARLISLE, MASS. 01741

IMAGE REJECTION DOWN CONVERTER FOR OUTDOOR USE

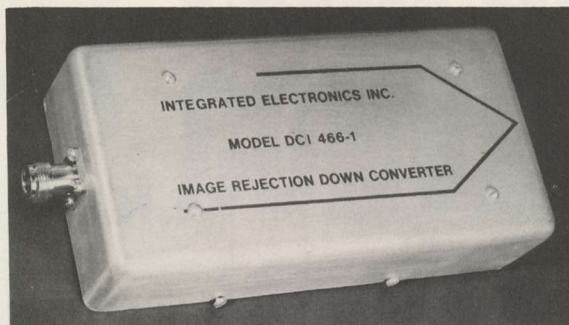

Do your TVRO down conversion at the antenna where signal to noise ratio is optimum and avoid costly microwave cable.

The DCI 466 is a completely self-contained unit housed in a weathertight case that converts the TVRO band to 70 MHz. DC power and a 17 to 25 volt local oscillator tuning voltage are superimposed on a single RG 59 line for easy installation. This converter features a low noise microstrip design that reduces LO leakage and practically eliminates frequency pulling over the TVRO band. An on board IF amplifier matched to 75 ohms gives plenty of drive for long cable runs. Overall conversion gain is 25 db. The unit's 50 ohm input measures a 12 db noise figure. The DCI 466 is priced at \$300 in singles. Delivery is from stock to four weeks ARO.

INTEGRATED ELECTRONICS INC., Box 240, Carlisle, Mass. 01741 617-369-0536

SPACE CONVENTION and EXHIBITION

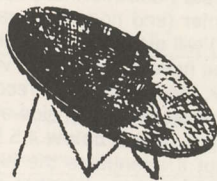

August 4-7

Omaha, Nebraska

The spectacular growth of private and commercial earth stations in recent years distinguishes it as one of the new and exciting industries of the 1980s. The frontiers of this new technology are just now being explored – and all indications are that earth station reception of satellite transmitted programming will revolutionize the way Americans receive video entertainment in their homes.

Demand for this technology is so tremendous that the earth station industry trade association, SPACE (The Society for Private and Commercial Earth Stations) has put together the largest convention and exhibition of satellite earth station equipment. You'll want to be there to examine and participate in demonstrations of the most advanced technology in the earth station industry. Recognizing the growing business opportunities provided by satellite delivered television, the convention's theme is **THE DEALER/RETAILER – THE VITAL CONNECTION BETWEEN THE SATELLITE AND THE CUSTOMER.**

Three information-packed days of seminars and panels will cover issues of paramount importance to the earth station industry, including: Marketing Techniques, Financing, Satellite Master Antenna Television, Legal Issues, Technical Aspects, and more.

Special guest speakers will include Congressman Charlie Rose (Chairman of the House Broadcast Committee) and Congressman Billy Tauzin (member of the House Subcommittee on Telecommunications), as well as other public leaders in the communications field.

SPACE will hold a special "pre-conference" orientation seminar on August 4 for prospective earth station dealers. Individuals new to the industry, who are considering becoming earth station dealers, will find this an informative and important opportunity to learn about earth stations.

No other event this year is more important – plan to be there August 4-7 in Omaha, Nebraska.

CONVENTION REGISTRATION:

Registration fees for the SPACE Convention and Exhibition August 5-7, 1982, are:

General Admission \$150.00
SPACE Dealer Members \$ 50.00

— I will attend the Pre-Convention Intensive Seminar for new dealers on August 4, 1982 (no additional charge.)

Please enclose a separate check payable to:
SPACE Convention Fund in the amount of your registration fee.

HOTEL RESERVATIONS:

A \$60 deposit will reserve all rooms. Please make a separate check for hotel reservations payable to Holiday Inn. Your registration will be confirmed.

Room rates: One double bed \$39.00
Two double beds \$44.00
One king size bed \$49.00

— My registration fee (check payable to **SPACE Convention Fund**) is enclosed.

— My \$60 room reservation deposit (check payable to **Holiday Inn**) is enclosed.

Individual Name: _____

Company Affiliation: _____

Address: _____

City: _____ State: _____ Zip: _____

Phone: (_____) _____

Type of room desired (indicate order of preference):

One double bed _____; Two double beds _____;

King size bed _____

Number of persons per room: _____

Date of Arrival: _____ Number of nights: _____

Mail form and checks to: Space Convention c/o Holiday Inn,
3321 South 72nd Street, Omaha, Nebraska 68124

to wideband video signals. It cannot demodulate these little, narrow band signals. So rather than plugging a video monitor (or an RF modulator) into the video output spigot on your TVRO receiver, we plug in a receiver that is designed, on purpose, to tune in this frequency range (0.1 MHz to 8.0 MHz), and which is equipped to demodulate these little, narrow band carriers.

That receiver is (or would be) a 'single sideband' communications receiver. Now, what is (and why do we use) single sideband? Well, in an effort to stack as many of these narrowband signals as possible into the available spectrum space, the uplink folks have decided (again, based upon work pioneered more than twenty years ago in the telephone industry) to use a particular type of AM called 'single sideband.' In this particular type of amplitude modulation, it is recognized that any 'full,' or 'normal,' AM signal is redundant. There is a carrier (to which the modulation is applied), and then separated slightly from that carrier (in frequency) there are two, equal **and identical**, 'modulated sidebands.' If you speak into a microphone connected to a 'normal' AM transmitter and say 'hello,' you could, with the appropriate single sideband receivers, hear yourself say 'hello' on **both** the 'lower sideband,' and, the 'upper sideband.' As this is not a 'stereo' service, that seems very wasteful since a carrier plus two sidebands takes up slightly more than twice the spectrum space that just a **single sideband** would occupy. So it evolved that since frequency spectrum was limited, that this technique of stacking twice as many signals into the limited available frequency spectrum was adopted. They do this by eliminating both **one** of the sidebands (which one is not important; they are exactly alike), **and**, the carrier as well.

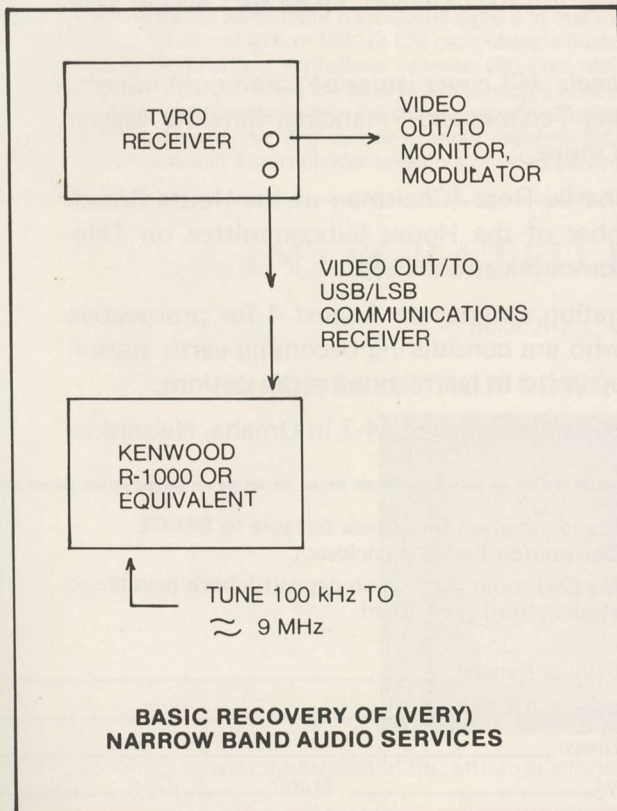

All of the narrowband signals we shall discuss and deal with here are transmitted on satellite in this manner. That says that to tune them in, so you can understand what is being said, you need to equip yourself with a 'single sideband receiver' capable of tuning the frequency range between 0.1 MHz and 8.0 MHz.

Now most of the home style TVRO receivers that include a video output spigot (most do, since you need this to plug the TVRO video into your outboard or accessory RF remodulator) have a circuit built into the receiver which limits the (AM) frequency range coming out of

the TVRO receiver video spigot. David Barker, in his **TVRO Notes** section of **CSD** this month, touches on this point. The problem here is that if a TV modulator or a TV monitor is connected directly to the TVRO receiver demodulator, not only will the video information come out of that spigot, but the audio subcarrier (and noise) appearing **higher** in the spectrum (**above 4.5 MHz**) will **also** be present there as well. For this reason, to insure that you have a high quality video signal to your modulator or video monitor, most home style receiver manufacturers install a circuit called a '**low pass filter**' inside of the receiver. This circuit allows the (AM range) signals **below 4.5 MHz** (i.e. the video information) to 'pass,' but it attenuates the higher frequency information (above 4.5 MHz). The net result is that when you plug a single sideband receiver into the video output spigot on your TVRO receiver, you get a high quality amount of signal for the region between approximately 0.1 MHz and 4.5 MHz; but (depending upon the design and quality of the TVRO receiver low pass filter) you may not get much signal above 4.5 MHz. For normal television use, this is desirable. For purposes of connecting an outboard single sideband (SSB) receiver to the video output spigot, and tuning in the narrowband signals, this usually means you lose sensitivity (signal level) on **that portion** of the (AM) spectrum which appears **above** the cut-off-frequency of the filter; or, 4.5 MHz.

This is not an insurmountable problem. One solution is to seek the advice of the TVRO receiver manufacturer, and learn where (and how) you can tap into the TVRO receiver demodulator circuit to bring out a lead (through a coupling capacitor) to a new coaxial jack you might add on the back apron of the receiver. If you tap into the demodulator ahead of the low pass filter, you will then couple to the

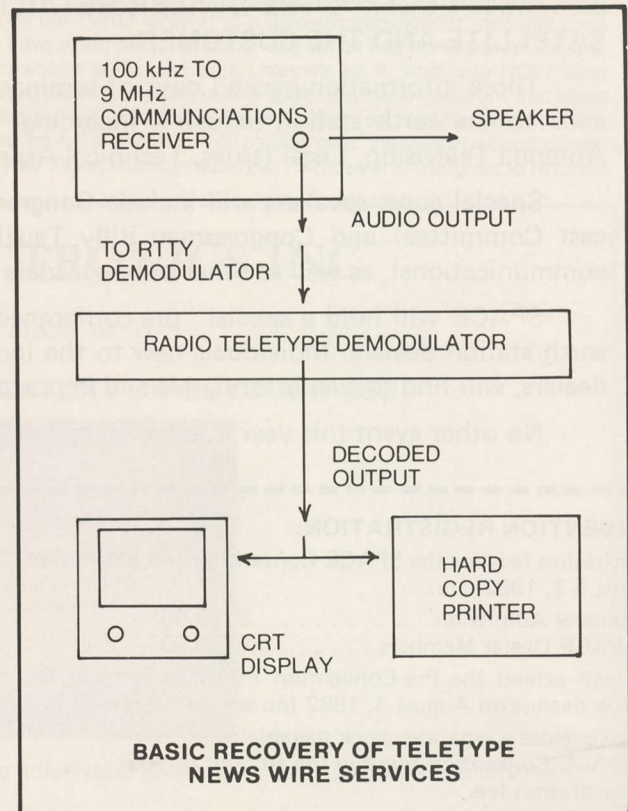

new apron-added output jack the **full spectrum** from approximately 0 MHz to the limits of the demodulator system; near 8.0 MHz.

In practice, even when tapping or plugging into a receiver's **normal** video output jack with a single sideband receiver, when there is a 4.5 MHz low pass filter in that line, you will **still hear signals above 4.5 MHz** on your SSB receiver. It will just reduce them in level. In some installations, the narrowband signals are so strong that you won't even be able to tell the difference (by ear).

Continued/page 50

CREDIBILITY

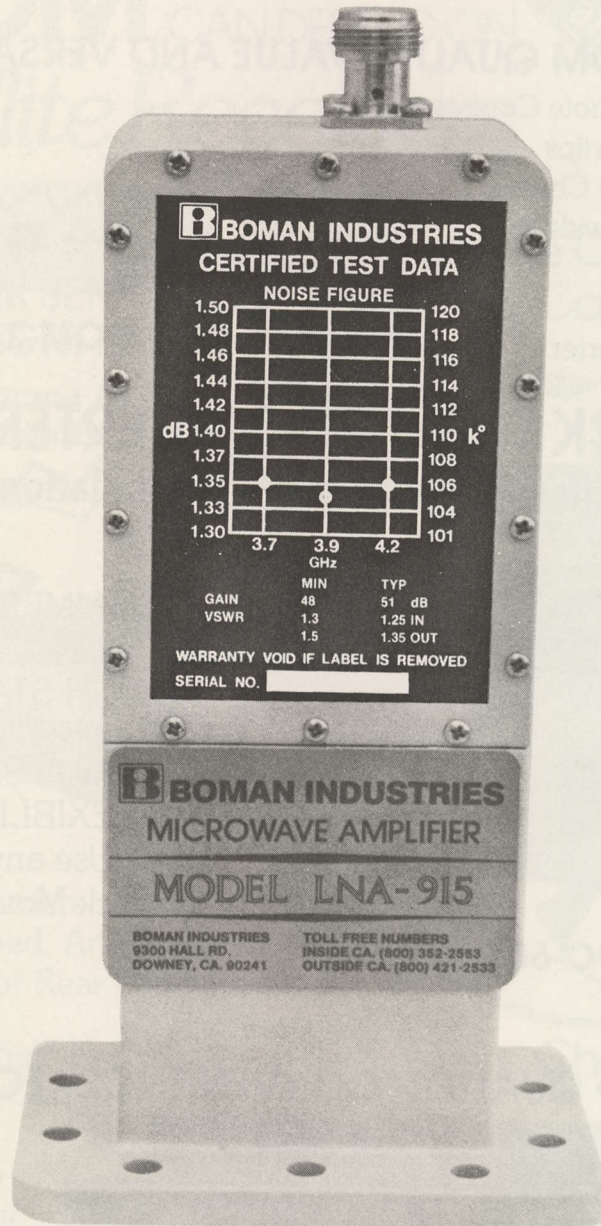
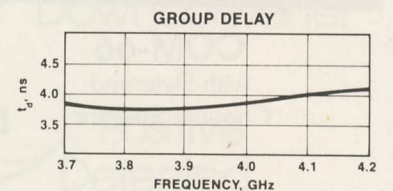
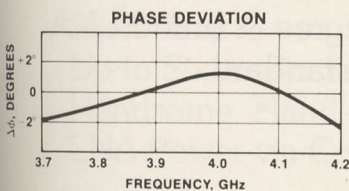
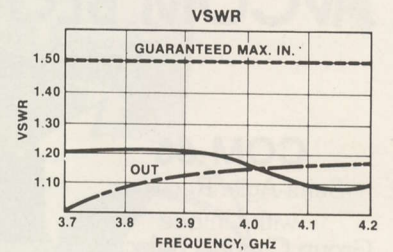
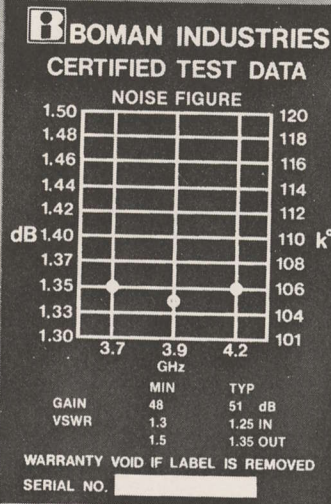
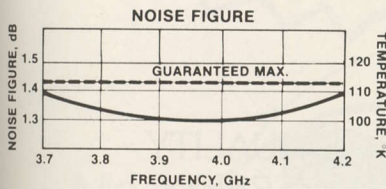
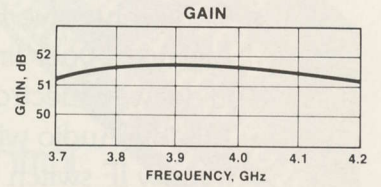
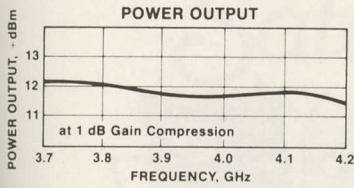

All Boman Microwave Amplifiers are 100% tested and marked for each guaranteed test parameter before they are released. All measurements are taken with equipment calibrated and maintained in accordance with military standard MIL-C-45662.

We at Boman believe our continuing research and development of Satellite receiving equipment will insure that all Boman products will be the finest systems you can buy.

BOMAN INDUSTRIES
SATELLITE PRODUCTS DIVISION
9300 HALL RD., DOWNEY, CA. 90241 • (213) 869-4041

TOLL FREE NUMBERS:
INSIDE CA. (800) 352-2553
OUTSIDE CA. (800) 421-2533

AVCOM introduces

5 NEW High Performance Receivers!

COM-2 • AVCOM QUALITY, VALUE AND VERSATILITY

- Comprehensive Remote Control—
Always at your fingertips
- Hideaway Electronic Chassis
- Tunable Audio with wide & narrow IF switch
- Scantune
- Remote Downconverter

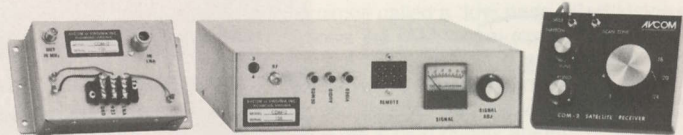

COM-2

AVCOM BLOCK DOWNCONVERTER SYSTEM

For Cost-Effective Multi-Channel Installations

COM-65

Semi-Agile Receiver
with Unique
Group Channel Selector

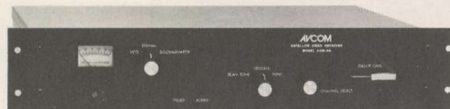

- COMMERCIAL QUALITY
- DOUBLE CONVERSION
- HIGH STABILITY
- COMPATIBLE
with SA's 6650 system

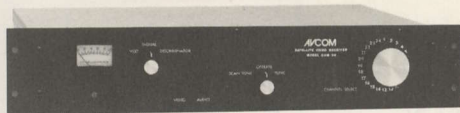

COM-66
with Detented
Channel Selector

- FLEXIBLE DOWNCONVERTER—
Use any degree & brand LNA
- Rack Mount, standard



BDC-60

COM-11 & COM-12 • QUALITY • CONVENIENCE • ECONOMY

- Remote Downconverter
- Scantune, AFC & Signal
Strength Meter
- Tunable Audio Board
- Rack Mount

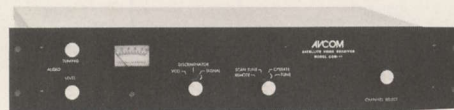

COM-11
Rack or Recessed
Channel Selector



COM-12
24-Channel
Detented Tuning



See your
AVCOM dealer

AVCOM
OF VIRGINIA INCORPORATED

Dealer Inquiries Invited

500 Research Road • Richmond, VA 23236 • 804/794-2500

AVCOM QUALITY YOU CAN DEPEND ON

Satellite Receivers

AVCOM's NEW OPTION
TAB-4 Tunable Audio Board
Wide and Narrow* IF Bandwidth!

NEW!
AVCOM's SUPER SENSITIVE
SIGNAL STRENGTH METER!

Peak your antenna to the
last 1/10 of a dB.

Remote Control
Capability

Modular
Circuitry

High
Performance
Image Reject
Downconverter

The COM-3

Scan-Tune
Up to Six Audio Subcarriers
Handsome, Hand-etched, Anodized Front Panel
LNA Power via Coax or Rear Panel Connector

Positive
Detented
Channel Selector

* For those "Special" Narrow
Bandwidth Sub-Carriers

AVCOM

- Conservative Design
- Exceptional Reliability
- Quality Construction
- Technological Superiority

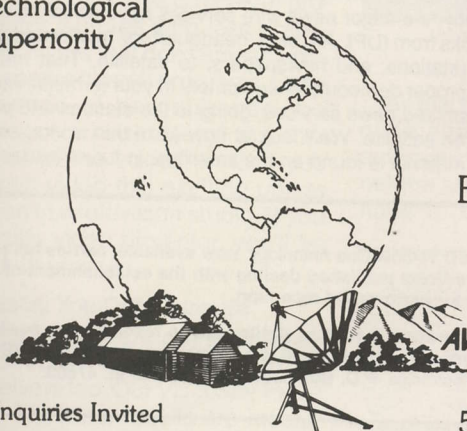

Dealer Inquiries Invited

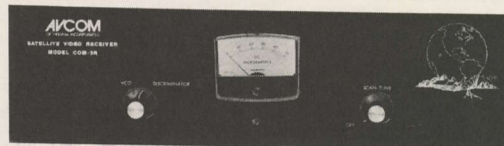

COM-3R complete with REMOTE CONTROL UNIT

Everything you need for your complete
Satellite Earth Station

ELIMINATE CANADIAN JINGLE WITH AVCOM's
OPTIONAL CAN-5 AUDIO FILTER BOARD!

See your
AVCOM dealer

AVCOM
OF VIRGINIA INCORPORATED

500 Research Road • Richmond, VA 23236 • 804/794-2500

The VCO Customized For TVO-8370 . . . Only from Avantek



Performance

- 3.6–4.2 GHz (3.5–4.1 GHz or 3.7–4.3 GHz optional)
- 10 mW Minimum Output Power
- Low –90 dBc/Hz Phase Noise (50 KHz from carrier)
- 45 MHz Frequency Drift, 0 to +55°C
- 47 MHz Pulling (all phases 1.67:1 VSWR)

Features

- High Output Isolation: Stable, Predictable Tuning
- Convenient TO-8 Package
- Draws only 50 mA @ 15 VDC
- Convenient, Hermetic TO-8 Package
- Available From Stock

With its optional frequency coverage, the TVO-8370 may be used as a low-side LO for 50 through 200 MHz IFs, and as a high-side LO for IFs between 50 and 100 MHz. Avantek also offers the UMX-4220, a double-balanced mixer and associated modular IF components specifically designed and priced for TVRO receivers. Contact Avantek for the address and phone number of your nearest stocking distributor, who will provide detailed information on performance and on our competitive pricing.

Avantek

3175 Bowers Avenue
Santa Clara, California 95051
(408) 496-6710

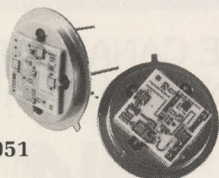

Continued/from page 46

The Connection

There are a wide variety of single sideband receivers on the market. Virtually all 'HF' (high frequency) Ham or amateur radios are single sideband units. Unfortunately, Ham units cover only specific ham bands (as a rule) and what you are after is a 'general coverage' receiver which has SSB tuning or demodulator capabilities. We invested in a Kenwood R-1000 receiver (** some years ago for this specific purpose, and have never regretted the purchase .

The specifications you are looking for are as follows:

- 1) The receiver should tune the region from 0.1 (0.2 nominally available) to at least 8.0 MHz, continuously.
- 2) It should have switch or operator selectable 'upper' sideband, 'lower' sideband and probably will also have AM.
- 3) If possible, it should have either a variable RF gain control, or a signal attenuator.

You unplug your TVRO to modulator or monitor line, and reconnect the modulator or monitor end of the cable to your selected SSB receiver. Switch the TVRO receiver to a transponder that has no video, but which you know has narrowband signals present. For example, transponders 5, 7, 11, 15, 18, 21, and 23 on F1 have narrowband services on board. Virtually all of the Comstar transponders, where you tune your TVRO receiver and see faint (or not so faint) diagonal or horizontal lines or banding, are carrying narrowband signals.

Turn on the SSB receiver and set the tuning range for the region between 0 and 1 MHz. Start at the 'low' end (around 200 kHz) and set the receiver to the USB (upper sideband) position. Look at the receiver's signal strength ('S') meter, if it has one. Note whether it is reading higher than S5 or so when you are tuned to no carrier signal. If it is, either turn down the receiver's RF gain control, or, switch the signal attenuator control so that the meter drops to a level near S5 when nothing is heard in the receiver speaker but noise.

Now start tuning upwards on the receiver dial. You'll hear a series of audio beats which change as you tune the receiver. As you continue tuning, you will notice that these 'beats' occur at approximately 4 kHz intervals. As you tune upward, you will find that there is a Donald Duck quality voice (or music) transmission on **some** of these 4 kHz spaced signals. Carefully adjust the tuning to make the voice sound as normal as possible. If it does not seem to 'tune in,' **switch to LSB** (lower sideband) and retune again.

Once you get the 'hang' of it, you will discover that as you tune along there will be a whole 'section' or 'spectrum' of signals which are transmitting in USB (upper sideband), and then there will be an abrupt change and for the next tuning segment all of the signals will be LSB (lower sideband). After a while, they'll flop over again. This is normal; part of the way uplinks from different regions of the country use the same transponder to stack chunks of spectrum on the same transponder.

You will also discover that there will be 'blocks' of similar sounding signals; a whole batch of telephone conversations (you only hear one side on a 'channel'; the other side is on another transponder going back the other way), a batch of '800 number' operators, a batch of network news and audio feeds and every now and again some strange sounding, non-voice transmissions.

Recently, the major news wire services have switched over their primary links from (UPI, AP, etc.) 'headquarters' to affiliated radio and television stations, and newspapers, to satellite. That means that given the proper demodulator equipment in your terminal, **radio teletype** transmitted news services, going to the stations and papers, is available on satellite. We'll look at how all of this works, and where all of this material is found on the satellites, in future issues of **CSD**.

* — CSD Volume One Anthology, now available, carries full reprints of all of the articles published dealing with the establishment of receiving terminals for narrowband reception.

** — Kenwood R-1000 or similar design receivers are available from many amateur radio suppliers. One such supplier, in the TVRO field, is Hoosier Electronics, P.O. Box 3300, Terre Haute, In. 47803.



Videophile Satellite Television

The possibilities of component audio come to satellite video.

Component equipment has become popular in the audio field for a lot of reasons. One reason is that the component philosophy allows a purist to upgrade any piece of a system as technology advances without having to replace the entire system at once. This basic idea has ushered in an era of specialty firms dedicated to advancing the art of a single link in the chain. They succeed because all of their efforts are focused on one discipline, not thinly spread over an entire system. EARTH TERMINALS™ brings this philosophy to satellite television. We concentrate on the single most important, most difficult element—the microwave receiver. No other part of the system has such a dramatic effect on picture quality.

Quality You Can See

An EARTH TERMINALS receiver provides cleaner pictures with less granularity. Truer colors that don't smear. Less sparkling snow on weak programs. Complete absence of herringbones and waves. Superimposed lettering that doesn't tear at the edges. In fact, you haven't seen video this exciting unless you've been in a television studio. If you own a quality video projector, you'll be even more impressed.

Quality You Can Measure

Broadcast engineers are impressed with the accuracy of EARTH TERMINALS receivers too. Our VITS Sin² Pulse and video SNR test results are incom-

parable; actually the equal of most commercial grade receivers. We can also handle tough signals like Reuters data transmissions that give other receivers fits. It's no wonder then, that after exhaustive testing, some cable companies and television stations use EARTH TERMINALS receivers as their main source of satellite program material. They know value when they see it.

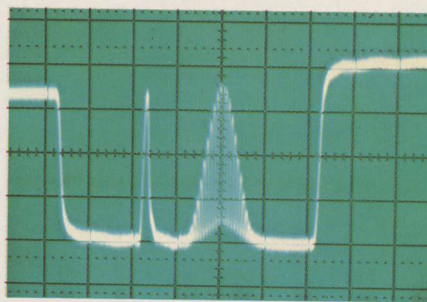

Unretouched Off-The-Air Sin² Pulse Test

It's Easy To Live With

All this technical sophistication is really quite easy to get along with. Precise automatic fine tuning tunes every channel the same way every time. You don't have to be an expert to get perfect

pictures. EARTH TERMINALS receivers come with a remote control that selects channels individually, adjusts audio volume at your convenience, and automatically signals the rest of your system to supply the proper antenna polarization through an even/odd channel switch. And it fits in the palm of your hand.

Tips On Value

There are plenty of satellite receivers that cost less than ours, but nearly all of them need bigger antennas and more exotic Low Noise Amplifiers for a picture free of sparkling snow. If you're on a budget, you can save money in other parts of the system by paying more for our receiver and come out even. You get high fidelity video in the bargain. If you're simply after the best picture money can buy, we can make it very affordable. Either way, give us a call or write us for the details.

EARTH TERMINALS
Department 103
255 Northland Boulevard
Cincinnati, Ohio 45246
513-772-6900

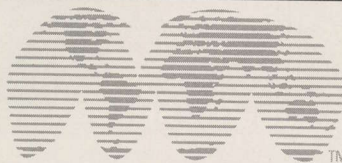

EARTH TERMINALS

BRIGHT NEW STARS ARE RISING!

To Scan The Satellites With FREEDOM:

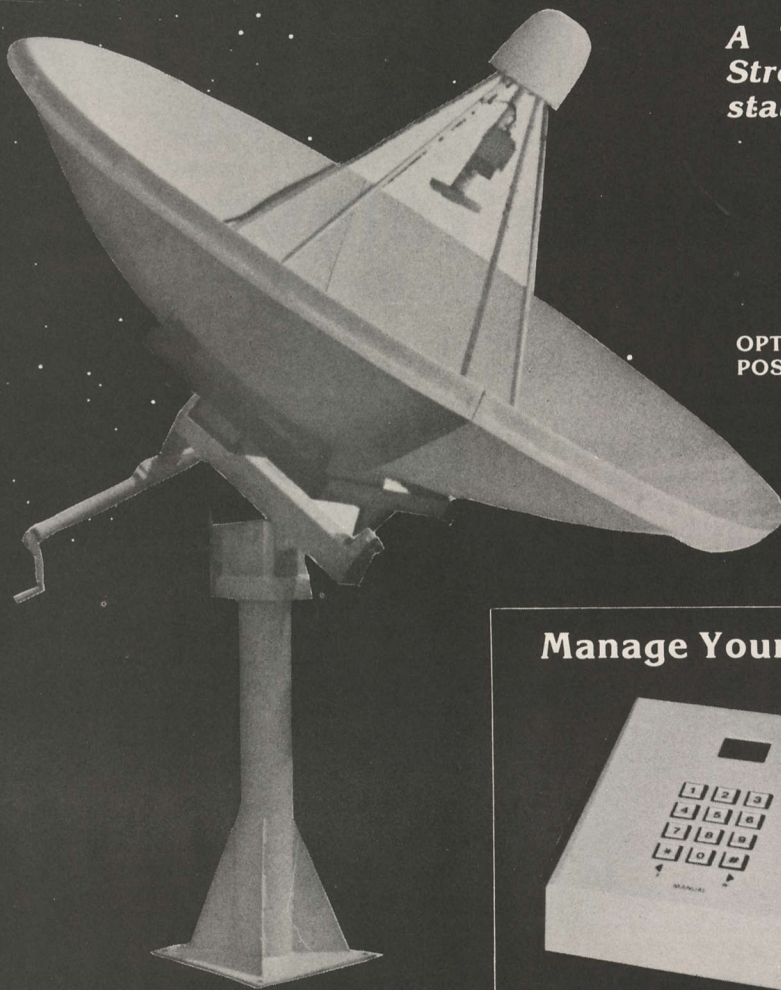

A Total System Combining Physical Strength, Neat Appearance, Ease of Installation and QUALITY COMPONENTS. .

10 foot dish
single pole base type polar mount
120 degree LNA
FREEDOM receiver,* down converter, modulator
complete cable assembly

OPTIONAL RECEIVER REMOTE AND PROGRAMMABLE DISH POSITION MANAGER AVAILABLE.

Manage Your Dish Position with FREEDOM!



A total retrofit system:

\$595.00

QUANTITY PRICES AVAILABLE

*Simple installation*programmable with the flip of a switch and the push of a button*8-hour memory retention in case of power failure*Dayton 90 v DC permanent magnet motor*incorporates Hall effect design for maximum reliability*solid state, digital readout, micro processor

FREEDOM to rotate your dish from the inside. FREEDOM from guessing that you are fine-tuned with the hand crank. . .FREEDOM to select over 45 pre-programmed stop locations by simply recalling the memory data by command through the keyboard.

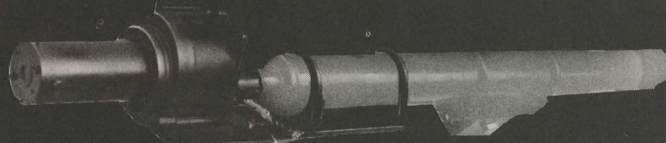

Complete system adaptable to almost all existing systems. Includes programmable control, motor drive, bracket assembly and 100 feet cable.

**TOTAL SYSTEM
PRICING AVAILABLE
UPON REQUEST.**

THE FREEDOM SEVEN SYSTEM

RECEIVER

\$599.00

QUANTITY PRICES AVAILABLE



**FREEDOM earth station
receiver with SEVEN distinct
QUALITY features:**

1. Signal strength meter. . . Allowing peak performance adjustments at a glance.
2. 24 Channel detent selector (with video fine tune).
3. Audio tune for all sub-carriers (5.7/7.2 MHz).
4. Scan tune. . . Automatically sweeps the satellite transponder band for signal detection.
5. REMOTE DOWN CONVERTER. Allows location at the dish for minimal line loss.
6. BUILT IN MODULATOR. State of the art allows channel 3 or 4 selection.
7. OPTIONAL REMOTE CONTROL video and audio. . . From your arm chair or from your 2nd TV set.



FREEDOM SEVEN

P.O. BOX 908

KIMBERLING CITY, MO.

65686

417-739-4264

DAVID'S TVRO NOTES

by
David Barker
GHz Engineering

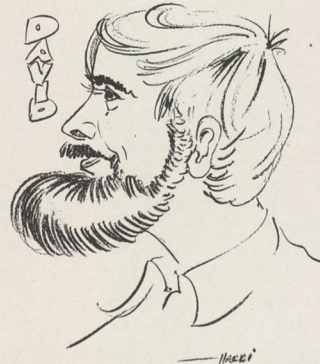

After being generated in the FM video demodulator, the video signal goes through several processing steps before being fed into a monitor, or, an RF remodulator. These processing steps normally include de-emphasis, low pass filtering, dispersal energy removal, and finally video signal amplification. **Figure one** shows this in block form for a typical TVRO receiver. In commercial (i.e. cable) TVRO systems, the low pass filter is found in the RF (re)modulator and not normally in the TVRO receiver.

The noise that comes out of an FM demodulator operating near or above threshold (i.e. a CNR greater than 8 to 10 dB, depending upon the particular receiver) is not 'flat' in frequency. This noise (or sparklies) increases in level as the video frequency increases (**Figure two**). To lower or reduce the noise at the higher video frequencies, a low pass filter is designed into the receiver. This filter is called the de-emphasis filter. Since it lowers the level of the higher video frequencies passing through it, the noise response of the FM demodulator after the de-emphasis network should be almost flat.

To make up for the loss of high frequency video information (this is the part of the video signal that creates the fine detail, and sharp color in the picture), the high frequencies are boosted or pre-emphasized at the uplink transmitter end. Since we have no control over how much pre-emphasis may be used, or the fact that it is used, at the transmitter end, the de-emphasis filter in the TVRO receiver is mandatory.

Examining the horizontal sync pulse (see **Figure three**) in a correctly operating TVRO receiver, before ('A') and after ('B'), shows the effect the de-emphasis filter has on the video passing through it. In 'A,' the overshoot is caused by excessive high frequency response in the pre-emphasis filter, located at the uplink or transmitter end of the circuit. 'B' shows the typical or normal shape of the horizontal sync pulse. Also, the noise that would be observed in making this examination of the sync pulse would be greatly reduced at the output end of the de-emphasis filter.

The Howard de-emphasis circuit, shown in **Figure four**, is taken from the EIA standard RS-250-B. The element values have been



FRANCIS
ENTERPRISES INCORPORATED
P. O. Box 906
Poplar Bluff, Mo. 63901
314-989-3248
WE ARE LOCATED 11 MI. SO. ON 87 HWY.

We
Build
Quality
Into
Our
Products

MANUFACTURERS | DISTRIBUTORS

Francis Ent. Inc. Introduces a precision built 11 ft aluminum antenna. Our 11 ft antenna is 24 sections of .090 ga. aluminum with all steel single pole polar mount. Our antenna and super mount weigh over 575 lbs., we believe the heaviest in the home TVRO industry, completely manufactured in our 20,000 sq feet plant. We have the complete system to fit the needs of the public.

Exclusive: One man Installation reusable trailer with Independent suspension.

Choice Dealerships & Distributorships still open in your area.

**Financing With "No Money Down"
Tax Free Profit
all of this and more in**

**HOW TO SELL
THE CONDOMINIUM SYSTEM**

includes: making the proposal, a sample tax return, negotiating with the bank, negotiating with the homeowners assn., plus much more!

send \$ 29.95 to:

**Satellite Television Systems
Rogers Plaza · 123 By-Pass
Clemson, S.C. 29631**

**A National Microtech Distributor
all Microtech distributors
receive a 20% discount
money back guarantee
if not completely satisfied**

Farsighted.

Experience System 7... a higher level of performance and reliability.

System 7 has every feature you've ever looked for in a satellite receiver: • Attractive styling • Excellent picture quality • Detent tuning • Matrix stereo • Signal strength indication • A.F.C. • Video invert • Built-in modulator • Antenna based, weatherproof downconverter • Optional remote control • Optional rack mount.

Lowrance has made subtle improvements on each feature, then put them all together in one system. We've added the kind of production and quality control that mean genuine reliability. Each receiver must pass more than 50 quality checks, and is "burnt in" (run under normal operating conditions) for several days. The result? System 7 is the satellite receiver that you've been waiting for.

Like other Lowrance products, System 7 is backed by a full one-

year warranty. When Lowrance Electronics produces a product, we seek and demand excellence. In engineering, production, quality control, marketing, distribution, warranty and service. That's why we've remained the leader in other electronics markets for over 25 years, and that's why we're so farsighted when it comes to satellite receivers.

For more information on System 7 or details on distribution and co-op ad programs, clip the attached coupon and mail.

LOWRANCE

LOWRANCE ELECTRONICS, INC.
12000 E. Skelly Dr., Tulsa, Okla. 74128

Yes! Send me more information about System 7.

I am End user Dealer Distributor

Name _____

Address _____

City _____ State _____ Zip _____



FIGURE #1

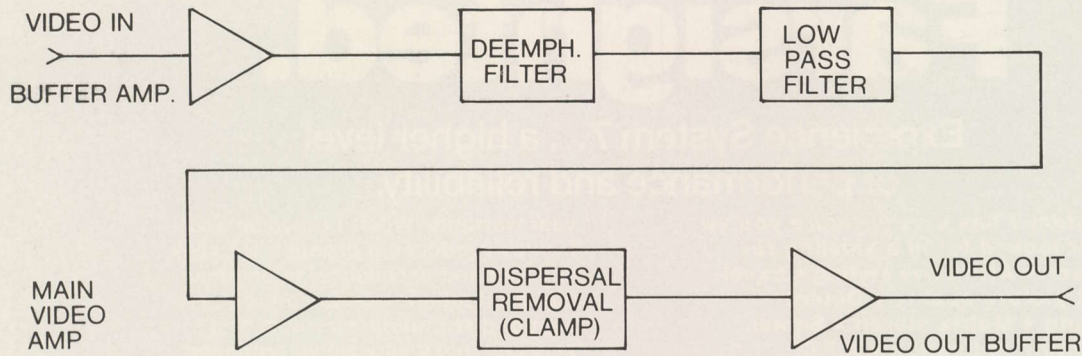

FIGURE #2

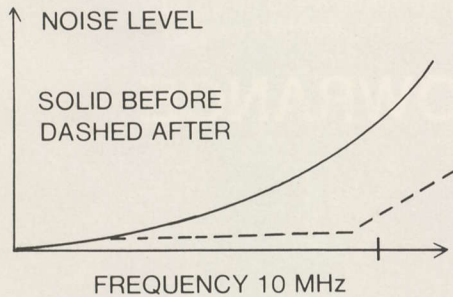
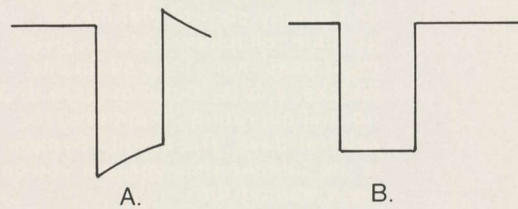

FIGURE #3



doubled (halved for the capacitor) to make the filter a 150 ohm filter rather than a 75 ohm filter. The de-emphasis filter can have other design forms as long as the final result is the same frequency response across the full video bandwidth, given the input characteristics of a pre-emphasized video signal.

The output of the de-emphasis filter, through a buffer amplifier, would be a useful output at the rear end of a TVRO receiver. This would be an ideal point to connect external audio processors and other video processors that might be needed to clean up 'scrambled' pictures.

The low pass filter that normally follows the de-emphasis filter further removes the high frequency noise and the audio sub-carriers. The problem with the standard 'Howard' type of low pass filter is that it only reduces the noise and the sub-carriers, doing some damage to the picture information in the process. The modifications shown in this column in the April CSD will help, but if the flat output after the de-emphasis filter is what you are after, a totally new filter design is called for.

A new low-pass filter for home use should have a bandwidth of 4.2 MHz and a notch at 4.5 MHz to keep noise (and video) out of the sound. The relative response of the new low pass filter should be $0 \pm .5$ dB at the 3.58 MHz (color) sub-carrier frequency, and greater than 30 dB 'down' for 4.5 MHz and beyond. This will be a big first step in improved video quality.

The early Howard receiver had the main video amplifier before the de-emphasis and low pass filters. The later Howard circuit (CSD, December 1979; available in the CSD Volume One Anthology, now on sale) had the video amplifier after the filters. This is the better of the two approaches. Or, to put it another way, as more and more signals and noise are fed through an active (amplifying) stage, the opportunity for increasing the distortion grows greater. The video amplifier should therefore be amplifying picture information, and not noise and audio sub-carriers. And thus, the filters should ideally be in front of the

amplifier. Finally, the video amplifier is a good spot to drop in any video polarity switching and a video gain control.

Where Is Poor?

Is the poor picture you are seeing on a standard TV fed by a TVRO (re)modulator due to the re-modulator, or is it being caused by the TVRO receiver? If you have access to a video monitor, the question is easy to answer. If you don't have a monitor, connect the RF modulator to the TV set **without** the TVRO video and audio connected to the modulator.

With the RF modulator connected alone, the TV receiver should be

FIGURE #4

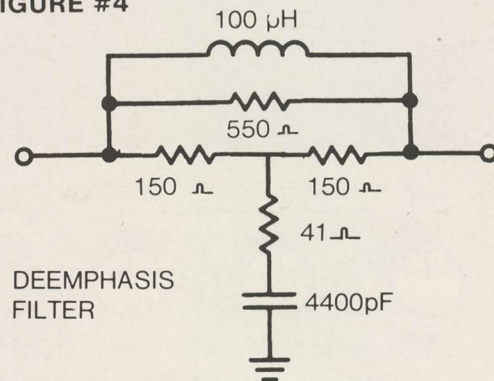

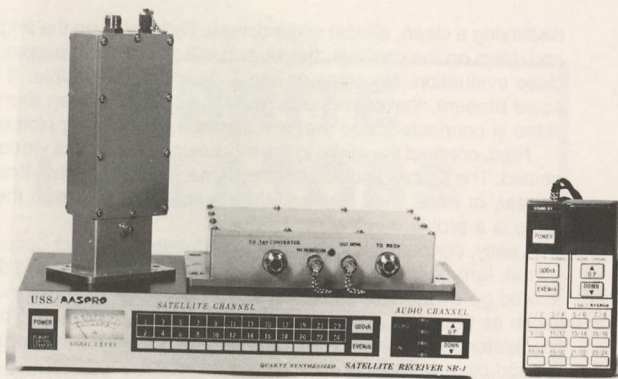

Introducing the
LATEST IN SATELLITE TECHNOLOGY

the new
SR-1 RECEIVER

For further information contact:

Starview of Texas, Inc.
15304 Midway Road
Dallas, Texas 75234
(214) 934-9126

featuring

PUSH BUTTON QUARTZ SYNTHESIZED TUNING - automatically locks into the channel - no fine tuning!

DUAL CONVERSION - no signal radiation.

100° LOW NOISE CONVERTER - standard feature.

AUTOMATIC AUDIO SCAN TUNE - scans until it finds a subcarrier in use.

AUTOMATIC POLARITY CIRCUITRY - with the addition of most automatic polarity rotors, polarity change becomes push button.

BUILT IN MODULATOR - channel 3, 4, and 5 available.

OPTIONAL REMOTE CONTROL - plugs into any wall outlet and allows you complete control from any room - turns the receiver on or off, changes channel, changes polarity and changes subcarrier - all with the push of a button.

EASY INSTALLATION - uses only RG 59 cable.

COMPETITIVELY PRICED - and the latest in satellite technology!

BETA 12 • 12 FOOT EARTH STATION ANTENNA WITH POLAR MOUNT

Laux Communications introduces the BETA 12 Earth Station Antenna with tracking polar mount. It's finally possible to sharpen up your picture with the added gain of a larger antenna without spending a fortune. The BETA 12 offers 42 db of gain and is light weight but rugged. The four fiberglass sections ship easily and can be assembled and mounted by a 2 man team. Clean up that marginal signal at a reasonable price! Give us a call and we'll give you the details.

BETA 12 FEATURES:

- * 4 piece fiberglass design
- * 42 db gain
- * Quality construction
- * Complete rotor mount included
- * Full tracking polar mount
- * Heavy duty mount construction
- * Optional motor drive with digital readout

Dealer inquiries invited

LAUX
COMMUNICATIONS CO.

8207 Mill Creek Circle • West Chester, Ohio 45069 • (513) 874-6900

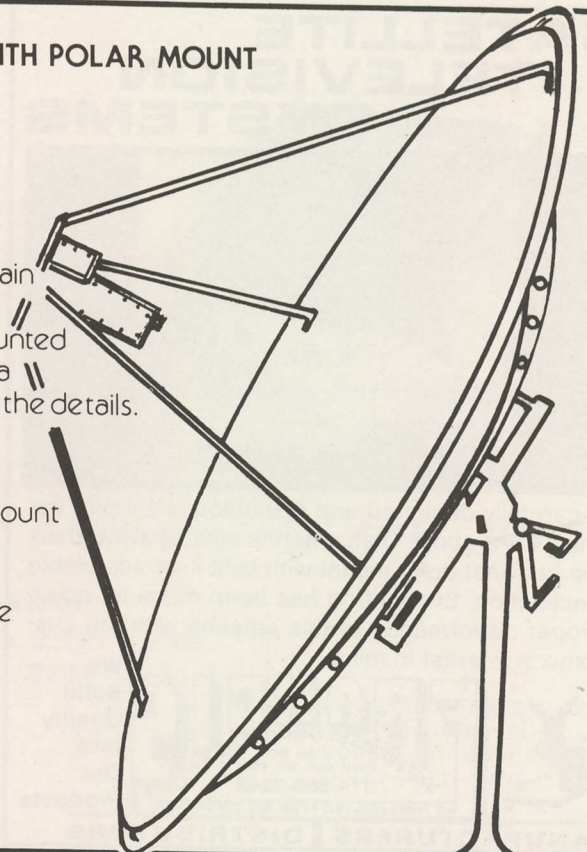

Aluminum LNA Mounts

All sizes

Milk Stool

or

Button Hook Type

SPS MFG. INC.

P.O. Box 1568

Conway, AR 72032

Phone 501-327-6579

SATELLITE TELEVISION SYSTEMS

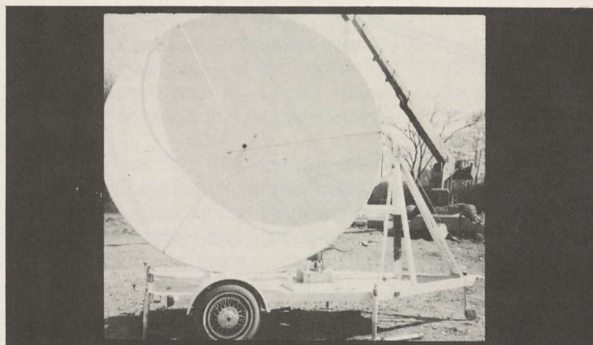

A carefully designed and manufactured top of the line 11' Parabolic Dish antenna with what we think the heaviest polar mount with built in or adjustable Declination. Every effort has been made to insure proper performance of this antenna with the customer's interest in mind.



FRANCIS
ENTERPRISES INCORPORATED
P.O. Box 906
Poplar Bluff, Mo. 63901
314-989-3248
WE ARE LOCATED 11 MI. SO. ON 67 HWY.

We
Build
Quality
Into
Our
Products

MANUFACTURERS | DISTRIBUTORS

displaying a clean, almost white screen. By turning up the brightness, and down on the contrast, the screen will go gray; the proper 'tint' for close evaluation. No noise or fine lines should be visible. If there is noise present, the same noise will be also there when the satellite video is connected, and that will degrade the viewing picture.

Next, connect the audio to the modulator, leaving the video unconnected. The screen should stay the same; clean and gray. If new lines appear, or if the lines that are already there 'wiggle' with the audio, there is a problem in the modulator.

Lastly, connect the video to the modulator. If a buzz occurs in the sound, turn down the video level in (on) the modulator and the buzz should go away. It is still possible to have 'beats' in the modulator (such as the color and sound producing a 920 kHz beat), but if the modulator passes this quick 'no-noise' test, it should be possible to get a good picture through it!

This series on the TVRO receiver will continue in CSD.

Continued/from page 3

and they incurred no 'copyright liability.' It was their position that if they were to license home viewers to watch them, their common carrier status would be in jeopardy. They obviously did not want that to happen; their whole business foundation was built on being a common carrier.

Parinello took a different approach. He said, to the amusement of some and delight of all, that he would accept on behalf of The Movie Channel orders and checks all day long for individual home terminals. Several handed their checks in at that point.

Long after Parinello left The Movie Channel, subsequent officials of the same firm were making the same statement. They even said they were accepting money from SMATV operators for stand alone apartments, condos and what have you. Not very long ago, in testimony before a House Subcommittee considering the Waxman bill, Warner Amex VP Andy Setos read into the record the following statements:

"Where we can legally do so, our company wants to make our program service available to the public via cable systems, MDS, master antenna systems and individual home users."

And he said:

"If the cable system within their area is not an affiliate of ours or cannot hook them up in a reasonable amount of time, then we will license them, whether they be an MATV system, or whether they be a private earth terminal in the backyard of someone's home, whether it be in the mountains, on a ranch, or in an urban area; but we will license them."

All of that rhetoric was for a Congressional Subcommittee wrestling with the wisdom of writing a law to make it illegal to view signals for which you do not have viewing authority. All of that rhetoric was designed to paint the folks at Warner Amex, that strange conglomeration of movies and entertainment and the American Express Card and insurance companies, as reasonable, helpful folks. All of that rhetoric was a bunch of crap.

In a letter dated September 1st, 1981, to a Jerry Dubiel of Belgium, Wisconsin, Warner Amex's Douglas Dexter (Director of Marketing Development) wrote:

"We are not presently able to license private earth terminals to receive our satellite programming."

In a letter dated March 8, 1982, to James F. Morrison of Colby, Kansas, Warner-Amex's Benson Begun wrote:

"Our program services are not available except with our specific written approval. We are in the process of formulating the terms and conditions upon which we would be willing to make Nickelodeon and MTV directly available at a retail level . . . to private individuals who own their own satellite receiving systems. The Movie Channel will not be made available. . . ."

In a telegram dated April 5, 1982, to David Ghysels of Dade Cable TV, Miami, Florida, Dexter from Warner Amex is back again with:

"... We are not accepting applications for the use of The Movie Channel, Nickelodeon, or Music Television . . . (for) residential properties."

So contrary to the official testimony of Setos, before a Congress-

FERRITE ISOLATORS

3.7 to 4.2 GHz

60 dB Isolation!

Insertion loss 1 dB Nominal

Quantity of 1\$249.00

2-4..... 225.00

5-9..... 205.00

List Price

Avcom can also supply your need for 2, 4 & 8 way Powerdividers, DC Powerblocks, Feed-line and Cable assemblies. Dealer and Distributor inquiries invited.

AVCOM OF VIRGINIA, INC.

500 Research Road
Richmond, VA 23236
804 / 794-2500

NEW PRODUCT!

ELECTRIC ACTUATOR

52" Stroke in 29 Seconds
Extremely High Quality
Design and Construction
110 Volts AC Standard

Special Dealer Pricing

Contact **AVCOM** 804-794-2500

OR

ADM 314-785-5988

For Brochure

(804) 794-2500 (314) 785-5988



"We're not afraid of competition...
we make it."

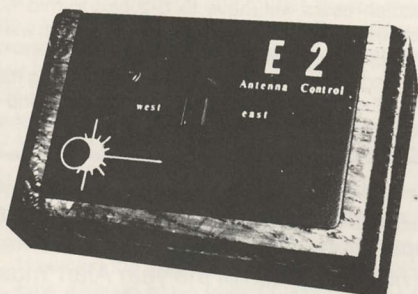

E2 Antenna Control

Complete	1	2-10	11-99
retrofit	\$395	\$249	\$198

Optional
limit set \$25

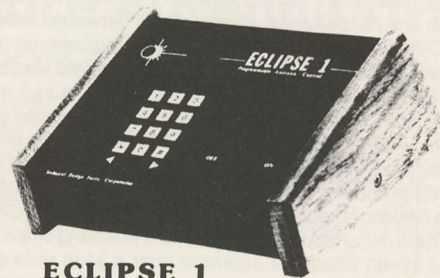

ECLIPSE 1 Programmable Antenna Control

Control only	1	2-10	11-49
	\$495	\$345	\$295

Complete retrofit	\$645	\$495	\$445
-------------------	-------	-------	-------

TECHNICAL DESIGN FORCE CORP.
234 NEOSHO BLVD.
NEOSHO, MO. 64850
1-417-451-7404

sional Subcommittee, Warner Amex is not, has not, and they claim will not engage in the licensing of private terminals. Period.

Why would an educated person, a VP of Marketing and Engineering (Setos is one talented guy!) for a major US corporation such as Warner Amex sit down before a Congressional Subcommittee and tell a deliberate falsehood? Why would a man discredit himself, and his company, before an influential group of Congressmen? Are these people really so inept that they don't know what is going on within their own shop? Or do they figure they are so big, so powerful, and so believable that they can appear in one forum and say what they think that forum wants to hear, rush out to a second forum and say something completely different, just to suit the climate where they are speaking?

TRANSPONDER WATCH

RECENT REPORTS OF ACTIVITY ON DOMESTIC / INTERNATIONAL SATELLITES

Send your reports to CSD Transponder Watch, P. O. Box 100858, Ft. Lauderdale, FL 33310. For late news, call (305) 771-0505.

HEAVY use of satellites during dispute over Falkland Islands brought renewed recognition of the importance of the new technology. Several 'coverage' holes became evident. Falklands lay so far to south that direct satellite communications would have required repositioning of bird due north of islands. ABC investigated feasibility of moving ship board uplink into area, came up with \$700,000 price tag plus extras that could not be estimated.

US television may finally be available throughout the Indian Ocean and Africa, under a pact signed between Defense Department and COMSAT. A single TV channel, programmed with 'best' of US network fare, sports and news will be relayed via INTELSAT to the U.S. Rapid Deployment Forces currently housed at various Indian Ocean sites. Apparently the service will be done using both full Global pattern (+22 dBw maximum) and full transponder on Intelsat located at 1 degree west. US uplink is at Andover, Maine site, and it is possible (but not probable) that a US domestic bird (Comstar) will be used to link to Andover before the signal is sent onto Indian Ocean via Intelsat. Start date not announced, but it bears watching since service could be useful (given adequate antenna) over a wide area of globe.

CNN, now scheduled to be seen 'live' in Australia on The Seven

Network during the Australian wee-night hours, is negotiating now with a cable TV firm in Tokyo for similar feed. By utilizing Pacific Ocean Intelsat bird to reach from USA to Australia, huge Pacific region is now capable of being 'marketed' by CNN. The CNN feeds will begin January 1, and will replace 'old movies' now carried on the network.

SHORTAGE, or scarcity, of 85 degree (and better) LNAs has several TVRO suppliers concerned. Ready availability of 100 degree units continues with indications that those suppliers who have been making 85 (or better) units available may be shifting priorities to faster moving 100 degree products. One LNA manufacturer attributes the shortage to the continued wide pricing difference between 85 and 100 degree units, and "the marginal — if measurable — difference between a quality 100 and an 85."

INDIAN INSAT-1 had 'miraculous recovery' after several weeks of attempting to make C band antenna unfurl. Bird went into orbit but failed to 'open up' on command. Ford finally got antenna to open, after weeks of trying, averting \$60,000,000 insurance claim. Bird will provide 12 C band channels plus 2.6 GHz downlink of national TV service.

WINNERS of Canadian DBS awards (see **CSD** for May) are up in arms over decision to allow first US users to call shots on bird bore-sighting. ANIK-C, scheduled for service late this year, very early next, is being leased as an 'interim' DBS system to a number of US would-be 12 GHz programmers. To accomplish this, C bird will be shifted to new boresight along northern US border. Arguments are a matter of 'timing' since Canadian users will move to C-2 bird in mid '83 and leave C(3) bird to US users. Eventually (84/85) all US users will move to first of new family of US operated 12 GHz birds.

MAJOR push is underway in Africa, by French speaking nations, to establish an AFSAT system to provide telephone, data and radio/television communications system over full continent.

OUR COVER — Alan Armbruster of Fairbanks, Alaska covers the far northern side of Alaska demonstrating home TVRO operation using a Luly Umbrella antenna. The dogsled is no prop; much of the year Alan 'mushes' into remote cabin sites with a complete terminal tied on the sled. The near-ultimate 'portable' TVRO system!

Microtech West

West Coast Representative for National Microtech

Available NOW!
Dealerships
Distributorships

Call COLLECT
for further information
(805) 922-8296



COMTECH, meanwhile, has denied it is actively engaged in conversations with RCA over DBS package; RCA refuses to affirm or deny report.

SUMMER CES gathering, underway as this reaches you, in Chicago, has developed into a minor-major showing for satellite manufacturers. Popularity of show to audio and video dealers provides reason for industry manufacturers to be on hand, hoping to draw new sales outlets into their systems. **LINDSAY America**, Canadian based manufacturer of TVRO antennas, using CES to unveil a pair of new screen mesh antennas with polar mounts; 10 and 12 foot diameter. Also being shown are three new fiberglass antennas in 10, 11 and 13 foot sizes.

NATIONAL Microtech has signed a \$5,000,000 order with M/A COM for electronics to go with the Apollo ZX satellite receiving system. The package provided consists of the low noise downconverter (LNC) which will be married to the Apollo Z1 home satellite terminal system.

RCA is apparently worried that the 12 GHz band may somehow end up being built in the sky without any RCA nameplates attached. They have filed applications with the FCC to build four 14 GHz up/12 GHz down satellites. The birds, to be built by RCA Astro-Electronics, would have 16 operating transponders each with 20 watts of power, plus four switchable backup transponders. Each transponder would be 54 MHz wide. RCA hopes to launch the first such bird in 1985, finishing up the third in 1987. The fourth is an on-ground spare.

ARIANE's launch, originally scheduled for April, put off to summer, has been put off again. The two satellites scheduled to fly are not ready, and ESA now sees that all launches for balance of this year may be pushed back several months. Best bet on a new launch date is September. Three Intelsat V birds, part of the near term Ariane schedule, will be pushed into early 83.

SBS is trying to hedge its bets with the FCC's proposed 2 degree orbital spacing. SBS 1 is presently at 100 west, SBS 2 at 97 west. SBS now requests consecutive spots at 92, 94, 96, 98 and 100.

BET (Black Entertainment Television) 'now says' it will not be on F4 afterall; has decided to work a deal with Westinghouse for one of the new W5 transponders which Westinghouse has ordered (10 ordered in all). BET continues short three hour feed per week on F3R TR9, will expand schedule to perhaps 40 hours weekly when it finally settles down.

STC's bid-call for designs for their proposed DBS system has drawn four serious applicants. They include RCA, General Electric, Ford and Hughes. SBS wants to have 2 12 GHz birds in the air plus a ground spare, initially, and will apparently only try to cover the eastern time zone. Each bird will have three channels, 200 watts power per channel.

RUSSIA is expanding the Intersputnik network with installation of full terminals in Syria, Laos and Iraq this year scheduled. Russia claims that as much as 40% of the television exchanged by members of the Eastern European block's Intersvision system now is relayed via Ghorizont.

Recent Occasional Feed Observations

Data listed here is supplied by CSD readers and is considered accurate at the time of the reported observation. However, occasional feeds can and do move around quite abit, and for this reason listings may only be good for a short period of time. Transponder user 'patterns' do evolve, however, and for this reason the data is presented here as a 'guide' to transponder usage. Regularly scheduled program transmissions, listed in **Satellite Week** or **Satellite Guide** are not covered here.

F1 (135 west)

Recent video activity has been limited.

TR1 / WOLD Los Angeles for feeds of independent (non-network) programs and news feeds.

F2 (119 west)

TR8 / The bulk of the transmission day, under lease to Robert Wold, is made up of transmissions from CNN going to Alaska. However, the **TODAY** program is transmitted weekdays on a tape delayed basis from 11 AM to 1 PM (ET); **ABC World News Tonight** is transmitted twice from 6 PM to 6:30, 6:30 to 7 PM. **NBC Nightly News** is transmitted from 7 PM to 7:30 PM

ENGINEERING CONSULTING SERVICE

Complete earth station integration
 Technical consulting for new T.V.R.O. businesses
 Training and education
 Product evaluation—Antennas, Receivers, etc.

SATELLITE RECEIVING SYSTEMS

Mike Gustafson
 1606 Capitancillos Dr. San Jose, CA 95120
(408) 268-3935

NETWORK

AFFILIATES WANTED

National Microtech wants dealers interested in one-day rentals of Earth Stations. Up to \$1200 per day. 10 engagements per month possible. Join our network now.



Call today

1-800-647-6144

Apollo X1 T.M.
Remote Antenna Lift
 wholesale dealer price **\$495**

Microtech's engineers have broken the price barrier with a high quality retrofit antenna lift. An industrial quality actuator takes the place of the old trailer jack on polar mounts. The contemporary styled remote control allows antenna direction from the easy chair. Call Dave Fedric at Microtech today, **TOLL FREE 1-800-647-6144**, for all the details.



National Microtech

BREAKTHROUGH Apollo Feed

These new high performance feeds are ready for immediate delivery From National Microtech, Inc.

1 unit	\$59
5 units	\$49
10 units	\$42
100 units	\$35

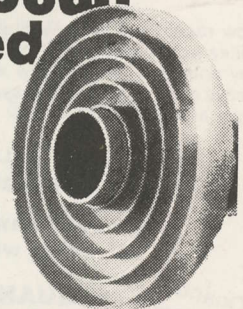

1-800-647-6144

AUTO POLARIZATION SWITCHING (LULY POLARIZER) Drake ESR24 Satellite Receiver

- Installs in Drake ESR24 Receiver
- Prewired 4 wire connection
- PC size 1.75" x 3"—LED indicator—Zener Regulated—3 amp reed relay
- Front Panel switch for opposite polarity (Westar vs. Satcom)
- Complete Parts and Instructions

Can be adapted
to other polarizers

\$49.95

In Stock Off the
Shelf Delivery

CIRCUIT ELECTRONICS, INC.

332 North 9th St. • Salina, KS 67401 • (913) 827-4521

THE MISSING LINK for EASY ACCURATE POLAR ALIGNMENT

Our optical Precision Celestial Pole finder (USA Pat. #4,260,253) will make the job of aligning a polar antenna painless, without leveling anything, for super accurate tracking. Every installer needs one. **\$159.** Write for information.

Roger W. Tuthill, Inc.

11 Tanglewood Lane
Box 1086 TV
Mountainside, NJ 07092-0086

Satellite TV Guide

Complete Schedule
for all the satellites

132 pages

Programming

Technical information

TVRO CATV

MDS LPTV

SEND TO:
SATELLITE TV GUIDE
P. O. Box 53
AYDEN, NC
28513-0053

Enter my subscription for
12 monthly issues

- one year — my check for \$65 is enclosed
 two years — my check for \$95 is enclosed

Name _____

Address _____

City _____ State _____ Zip _____

"SATELLITE SELECTOR" SYSTEMS

Now receive all the satellites easily and quickly, changing satellites from your control room. Universal model for adaptation to any polar type mount. Low voltage control with 110 volt motor. Heavy duty — jack screw system with 1860 lbs. force, stabilizes polar antennas.

Lights, Meter, or LCD Indicators now available or new - Satellite Selector Switch

New - Saginaw Jack Conversions - Motor with Indicator

Quantity
Discounts

QUANTUM ASSOCIATES, INC.
Box 18, Alpine, WY 83128 (307)654-2000

(ET).

F4 (83 west)

TR18/ HBO transmits promotional materials for Home Box Office and Cinemax around 9 AM (ET) weekdays; plus transmission of sporting and news events on a leased-out basis at other times, mostly evenings for customers such as USA network (inward bound transmissions).

D1/D2 (87 west)

TR12/ 'AT&T Basking Ridge, N.J.' noted testing 1 PM weekdays; slide.

TR14/ Real estate and other teleconferencing noted afternoons, weekdays.

TR24/ Color bar testing noted mornings and afternoons, weekdays.

W1 (79 degrees anticipated)

To press time, no reports of the re-activation of W1 at a temporary location assigned of 79 west. Location of the bird at present time not known.

W3 (91 west)

TR3 / Sheraton B.A. (Buenos Aires) feeds most mornings 7 AM ET to 8 AM including CBS, NBC and CNN (pool).

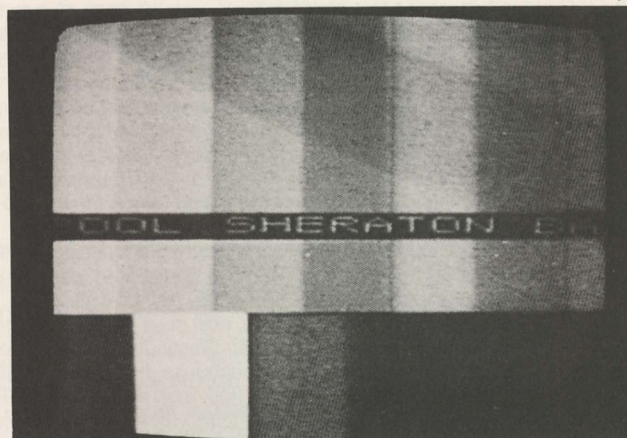

TR5 / DALTOC (Dallas Toll Operations Center) noted testing 7 AM ET; after May 3, **Good Morning America** (ABC) inward bound weather feeds with John Coleman noted here, having moved from TR 17, same bird.

TR9 / **ABC Good Morning America** inward bound interviews noted here 7 AM to 7:30 AM; CBS TV New York noted here some mornings with color bar, followed at 7:30 by **Captain Kangaroo**, **CBS Morning News** 8 AM to 10AM (central time zone feed).

TR15/ NBC BLU (e) Network feeds seen here mornings (9 AM).

TR17/ **ABC Good Morning America** inward bound weather feeds here until April 30; portions of **CBS Sunday** program, and feeds Sundays mornings.

TR21/ **US AM** (CBN) feeds seen here 7 AM to 10 AM weekdays. **INN News** noted 9:30 PM weekdays (some days).

TR23/ News feeds from Pacific (Japan, Korea) noted here 6:30 to 7 AM ET some weekdays, to CBS. **Richard Simmons** feed normally here 7 AM to 8:30 AM ET weekdays. Group W **PM Magazine** feeds here some days 9 AM.

W4 (99 west)

TR2 / CBS TV New York City noted here some mornings 6:50 AM to 10 AM with color bars, followed 7:30 by **Captain Kangaroo**, **CBS Morning News**.

TR4 / Network news feeds inward bound from South America, Europe noted here 7 AM ET many mornings.

TR19/ **Merv Griffin** feeds 8 AM to 10 AM weekdays; **ABC Good Morning America** west coast feed 10 AM to 12 Noon (ET) weekdays; CBS London feeds to USA 12 noon ET. **Solid Gold** transmitted 12 noon Saturdays.

TR20/ ABC internal promotions transmitted 7 AM some days; portions of upcoming ABC prime time programs transmitted between 9 AM and 12 noon some days.

Throw away that jack handle and get THE KIT

THE SPACE-VU II

East-West Hands-On Locator



Relay operated, fuse protected, motor control unit specifically designed for the Retro Fit Kit and ADM Retro Drive.

Wholesale Dealer Price:
\$75.00

THE RETRO FIT KIT

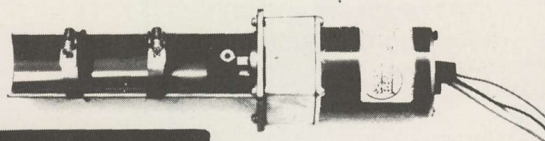

Wholesale Dealer
Price Roll-Back
1—\$170
10—\$155
25—\$145

YOUR ANTENNA JACK

Includes motor, couplings, mounting brackets, and instructions. Quantity discounts available.

ADM RETRO DRIVE

Complete actuator drive unit for ADM antennas now in stock. Wholesale dealer price \$250.00

CALL OR WRITE: SPACEAGE ELECTRONICS

Free shipping for cash in advance.

P.O. BOX 15730, New Orleans, LA 70175 (504) 891-7210

SPACEAGE ELECTRONICS

MICROCEPT

TVRO SYSTEMS AND COMPONENTS

PRODUCTS PLUS SERVICE AT LOW WHOLESALE PRICES

RECEIVERS: DRAKE, KLM, AUTO TECH
LNAs: AVANTEK, CALIFORNIA AMPLIFIER
ANTENNAS: ADM 11FT, KLM 12FT OR 16FT
REMOTE CONTROLS: KLM MOTO-TRAK, VECTOR 100

DISCOUNT LNAs

120°	\$489	110°	\$519
100°	\$599	90°	\$1,099

READY TO INSTALL SYSTEMS:

ADM 11ft., KLM SKY EYE IV, 100° LNA, CABLES \$2695.00
ADM 11FT., DRAKE ESR 24, 110° LNA, CABLES \$2995.00
KLM 12 ON 16FT, KLM RECEIVER, MOTO-TRAK, CABLES \$3995.00

ASK FOR OUR COMPLETE PRICE LIST AND QUANTITY DISCOUNTS

2596 BAY ROAD "D", REDWOOD CITY, CA 94063 (415-854-6163)



SEND ME, free of charge, the latest STTI brochure describing TVRO receivers and antennas I can build; TVRO satellite aiming (navigation) systems and techniques; TVRO system operational programs.

FREE STTI BROCHURE

Name _____
COMPANY (if applicable) _____
ADDRESS _____
CITY _____ STATE _____ ZIP _____

Send request to: STTI, P.O. Box G, Arcadia, Ok. 73007 or call 405/396-2574

ENTER MY 12 MONTH SUBSCRIPTION TO CSD / \$50 in US funds enclosed (for USA, Canada, Mexico only) starting with the very next issue.
ENTER MY 12 MONTH SUBSCRIPTION TO CSD / \$75 in US funds enclosed (for readers outside of USA, Canada, Mexico) starting with the very next issue.

12 MONTH SUBSCRIPTION SATELLITE DIGEST

NAME _____
COMPANY (if applicable) _____
ADDRESS _____
CITY _____ STATE _____ ZIP _____ COUNTRY _____

SUBSCRIBE TO CSD AT: CSD, P. O. Box 100858, Fort Lauderdale, Florida 33310

HERE IS MY ORDER for the full two-year CSD Anthology, 24 complete issues bound in two volumes, more than 1,000 pages strong; consisting of Volume One (Number One) through and including Volume Two (Number Twelve). My check for \$100 enclosed. (Note: Outside of USA, send \$125 US funds.)
HERE IS MY ORDER for just one Volume One (October 1979 through September 1980) of the CSD Anthology; including Coop's forward. My check for \$60 enclosed. (Note: Outside of USA, send \$75 in US funds.)
HERE IS MY ORDER for just Volume Two (October 1980 through September 1981) of the CSD Anthology. My check for \$60 enclosed. (Note: Outside of USA, send \$75 in US funds.)

24 ISSUE SET CSD ANTHOLOGY 1979 / 1981 !

NAME _____
COMPANY (if applicable) _____
ADDRESS _____
CITY _____ STATE _____ ZIP _____ COUNTRY _____

ORDER ANTHOLOGY FROM: CSD, P. O. Box 100858, Fort Lauderdale, FL 33310

INTRODUCING:

KLM's Sky Eye IV



**GREAT LOOKS, GREAT PERFORMANCE PLUS THESE
SUPERB FEATURES:**

- Video Inversion
- AFC Defeat
- "Center Tune" LED
- Slide Rule Tuning
- Remote Downconversion
- Contemporary Styling
- Latest Single-Conversion Electronics

Combine the new Sky Eye IV with a KLM 12' or 16' Moto-trak dish antenna and enjoy access to all the satellites at the twist of a dial. It's the ultimate system!

For more information, contact:

KLM Electronics, Inc.
P.O. Box 816
Morgan Hill, CA 95037
(408) 779-7363

SAT-TEC™ R2B

The leader in low cost TVRO



The R2B, the most highly integrated receiver on the market today!

Sat-tec

The name you know FIRST!

- FIRST Low Cost Receiver
- FIRST Volume Production
- FIRST With Off-Shelf Delivery
- FIRST To Ship the Innovative Divide By 2 PLL
- FIRST With Channel Lock AFC

The Sat-tec R2B receiver is our latest full feature receiver, tailored to commercial equipment specifications at a price you can afford. The R2B's single board construction eliminates problematic interconnections and

innovative utilization of all components results in a reliable and proven design. Operation is simple—a single tuning knob does it all, and our unique Channel-Lock AFC keeps the tuning sharp and accurate. A new feature is our variable audio tuning to give you complete selection of all subcarriers—without the use of additional plug-ins or devices. This, together with the R2B's full frequency coverage makes it truly compatible with all domestic and international satellites.

For superior value as well as lowest system cost, the choice is but one—the R2B! See your dealer today or write to us direct.

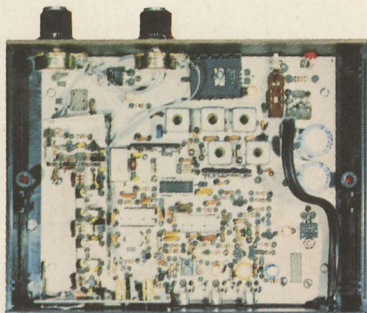

SPECIFICATIONS

Frequency range:	3.6-4.3 GHz tunable
Audio range:	5.2-7.6 MHz tunable
Threshold:	8db CNR
IF bandwidth:	30 MHz for full fidelity video
LNA power:	15 volts regulated for up to 2 LNAs
Outputs:	Standard one volt audio and video, compatible with VCRs, monitors and modulators
Optional:	BC-1 RF modulator kit, tunable channels 3-6 with sound



Sat-tec Systems

div. Ramsey Electronics, Inc., 2575 Baird Rd., Penfield, NY 14526, 716-586-3950