

“America is the greatest experiment in human freedom ever attempted by man. But it is not yet completed. And every generation of Americans should try to make it better...”

Author Unknown



E A T U

JULY
1976

100,000 TAPS
ARE IN SERVICE
FOR GOOD REASON...



NOTHING ELSE COMES
CLOSE TO OUR
PERFORMANCE
...AND ONLY \$5.50

No other tap combines these features:

- Non-Shearing Center Seizure Mechanism
- Eye-level Center Seizure Connections
- Modular
- 5-300 MHz
- Optional Anti-corrosion, Baked-on, Polyurethane Finish



Immediate Delivery-Call 513/258-2181

P.O. Box 3005, Dayton, Ohio 45431
an Arvin Industries Subsidiary

Coming through...

with one of the most profitable connections you'll ever make...

DUOBOND[®] drop cable

Belden's unique Duobond shields your profit by attacking profit-robbing connection problems and trouble-shooting headaches. Its aluminum foil shield is bonded directly to the core—not the jacket. Doesn't push back when "F" connectors are installed. You get more signal protection over the whole life of your installation.

Belden's a great connection for service, too. Such as our CATV special service group. If you need answers to installation and application problems, just call 317-966-6681.

Or SEED,[™] a revolutionary method of evaluating shield effectiveness. Helps you select the best cable for the job.

Handy selection guide. Cable answers to a wide variety of CATV system needs.

Quick delivery. We've committed production to drop cable exclusively in the CATV marketplace. So when you need it, we have it. Contact Belden for the best connection in the business. We'll come through with ways to save you time and money all the way down the line.

Belden Corporation, Electronic Division, P.O. Box 1327, Richmond, IN 47374, 317-966-6661.



Coming through...

with new ideas for moving electrical energy



Belden Corporation, Electronic Division
P.O. Box 1327, Richmond, Indiana 47374
Attention: Ron Stier

I'm interested. Send me your coax cable Selection Guide.

I've got a special problem. Have a Belden Coax Specialist call me.

Name _____ Title _____

Company _____

Address _____

City/State/Zip _____

Phone _____

Copyright © 1976 by Belden Corporation

SINGLE AIR COIL CONSTRUCTION VERSUS CHOKE COILS

RMS UNITAP construction reduces the possibility of critical hum level problems! Here's how...

1. The power passing network features a single "air coil" in conjunction with special capacitors to provide the lowest "hum level" available to the industry. (-65 db or lower, below signal reference line.)
2. A major factor causing some competitive taps to have excessively high hum levels is the limited amperage capacitance of the input and output power passing choke coils.
3. Choke coils create high heat levels even with low amperage input.

RMS CATV DIVISION
ELECTRONICS, INC.

*Remember at RMS we deliver
more than promises.*

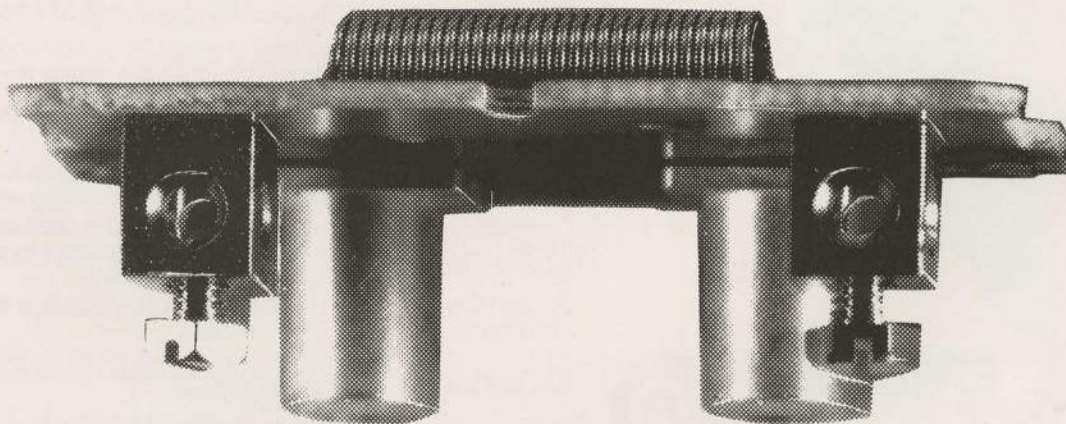

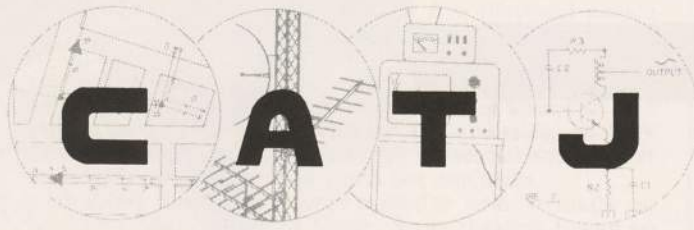

JULY 1976

VOLUME 3-NUMBER 7

PUBLISHED MONTHLY, AS ITS OFFICIAL JOURNAL, BY THE COMMUNITY ANTENNA TELEVISION ASSOCIATION, INC., OKLAHOMA CITY, OKLAHOMA AS A SERVICE TO ITS MEMBERS AND OTHERS PROVIDING CATV/MATV SERVICE TO THE TELEVISION VIEWING PUBLIC LOCATED THROUGHOUT THE WORLD.

OFFICERS

Kyle D. Moore, President
Ben Campbell, V.P.
G.H. (Bunk) Dodson, Sec/Tsr

DIRECTORS

Peter Athanas (Wisconsin)
Eugene Edwards (Ohio)
Warren Fribley (New York)
Charles F. Kee (Oregon)
Jim A. Kimrey (Arkansas)
William Risdan (Kentucky)
Carl Schmauder (Oregon)
Ben V. Willie (Iowa)

Richard L. Brown, General Counsel

STAFF

R.B. Cooper, Jr. Exec. Dir., Editor
Celeste Rule, Managing Editor
Richard Montgomery, Production Dir.
Peggy Jones, Editorial Asst.
S.K. Richey, Contributing Editor

OFFICES

CATA/CATJ
4209 NW 23rd, Suite 106
Oklahoma City, Oklahoma 73107
(405) 947-7664

CATJ subscription rates \$12.00 per year for non-CATA members, \$8.00 per year for CATA member-systems; \$9.00 per year for industry employed personnel for at-home delivery. In Canada, \$13.00 per year for CATV systems, \$10.00 per year for system employees. Foreign rates upon request.

Third class postage rates paid in Oklahoma City, Oklahoma, U.S.A.

The Community Antenna Television Association Inc. is a nonprofit corporation formed under Chapter 19, Title 18 of the Statutes of the State of Oklahoma. As such, no part of its assets or income shall be the property of its members; such assets and income shall be devoted exclusively to the purposes of the Corporation.

CATJ is Copyright © 1976 by the Community Antenna Television Association, Inc. All rights reserved. Quedan reservados todos los derechos. Printed in U.S.A. Permission to reprint CATJ published material must be given by CATA, Inc., prior to re-publication.

-CONTENTS-

10-4 / 10-4 / 10-4 — The CB Interference "monster" is causing hundreds of CATV systems serious problems. Is there a solution? Will the FCC Help? Who is to blame? When and where will it all end?10

KAY'S P9040 — Partly due to our CATJ pushing, we feel, the spectrum analyzer is coming of age in the cable industry. This month we take a look at one of the units available to the industry 26

THIS IS THE WAY IT WAS — The nation's bi-centennial celebration has everybody "remembering when"; this month in particular. CATJ goes back to the earlier days of cable, and re-creates several exciting years before the feds and before franchise raiding and before CB interference; in our salute to an industry.....31

THIN MARGIN III — Not here this month. Even with 8 more pages than normal, we had to put this one on "ice" until August.

DEPARTMENTS

CATA-torial (Kyle Moore on deep throats and dirty bears)..... 4

TECHNICAL TOPICS (Correspondence, Briefs).....50

4.5 Meter Dish Installation

Industry Licensing Of Personnel

Satellite Pre-Amps

NOAA Weather Service—Again

Can CATV Subs Help?

Looking For Help

CATJ's New Wall Chart

ASSOCIATES ROSTER.....55

ASSOCIATE'S SHOWCASE.....56

OUR COVER

Several months ago a CATA Director (Kimrey — who else?) suggested our July cover salute the Bi-centennial with a re-creation of George Washington crossing not the Delaware but the Potomac; with the Capitol in the background and Washington transporting a rag-tag band of CATV operators to Capitol Hill to recite their "grievances". We almost did it, but decided that for once we would play it straight. We believe the "author-unknown" quotation on the front cover says it all.

CATA "TORIAL

KYLE D. MOORE, President of CATA, Inc.



NITRATE TO VIDEOTAPE

There are now approximately 50 CATV 10 (or 11) meter earth terminals in operation, and more being applied for every week. By the end of this summer, hundreds of CATV system operators who previously have considered satellite delivery of programming out of reach may find it is no longer out of reach; financially. With the August 9-11 showing at CCOS-76 of an operating, "reasonably priced" 4.5 meter earth terminal, and a one day long CCOS "seminar session" on the practical problems of bringing HBO or Optical or other satellite-delivered programming to small town America, only one link will be missing for approximately 600 to 800 "small" rural systems to join the race to outer space. That link is FCC approval of CATV earth terminals utilizing antennas smaller than 9 meters in aperture. CATA, during June, filed a formal "Petition for Rule-making" with the FCC, in which this national trade association asks the Commission to re-write the rules to allow CATV systems to utilize whatever terminal antenna size they wish. When the FCC approves this rule change, a new revolution will be underway.

However, before this one gets started, it might be well to consider, in the cold light of day, just where all of this might be headed. It is one thing to create the technology (i.e. the low cost terminal), and to remove the legal restrictions (i.e. change the FCC rules). It is perhaps quite another thing to make all of this fly with a profit on the bottom line.

If the program distributor (i.e. HBO) demands 50% of our take, and we charge \$9.00 per month for a 12 hour per day "pay cable channel", that leaves us with \$4.50 for our own efforts. Out of that \$4.50 we must pay off the terminal, operate the terminal, handle an increased work load (new connects and dis-connects for the pay option service), handle an increased paperwork load (special billing) and somehow cover the cost of scrambling the pay channel or trapping the pay channel, as we choose. At some point around 200-300 pay-option subscribers, you may be in business with a \$25,000.00 terminal; provided you can somehow arrange to buy it or lease it so that your monthly terminal costs are not over \$650. to \$700. per month. Obviously, with a break-

even number such as 200-300 pay cable option subscribers, specialized programming such as offered by HBO or Optical is suddenly going to show up in a large number of until now isolated and rural American towns.

It would be well, at this juncture, to recount some of the problems which small town America theaters (i.e. movie houses) have faced in the past 25 years, for there are perhaps lessons in the plight of the movie house for all of us.

Twenty-five years ago a movie house in a small town had 500 new domestic movies per year to choose from. Most of these could be rented by the movie theater operator for from \$12.50 to \$25.00 per "run", and a run was typically up to five days. With lots of movie product available, and rates reasonable, you can quickly see how a theater could run Saturday morning specials (in the days before cartoon-Saturday hit television) for 10 cents a pop, or rotate movies every couple of days and make a go of it.

By ten years ago the domestic movie product had dropped to around 150 new films per year, at the remaining 8 major film production companies; and with a scarcity of product came new rate structures. Even low prestige films had risen to \$25.00 per week or 25% of the gross. If the gross was less than \$100.00, then the minimum fee of \$25.00 applied. If the gross was sufficient so that 25% equalled more than \$25.00, then the higher fee appeared. But there was a hooker, and that was picture "content."

Where American movies were a family tradition in the 30's and 40's and even into the 50's, the family as a unit began to stay away by the mid 50's. Throughout the 50's and 60's the average age of the typical movie goer was in the low "20's." It has fallen slowly but steadily ever since. The movie production people have reacted by creating specialized movies that appeal to specialized audiences. And the "R" and "X" rated movies were born.

Today, with the total movie production down to no more than 150 pictures at the Big-8 production companies, and with 80% of these "R" or "X" rated, the small town theater operator finds himself in a tight spot. Deep Throat might play well in Cleveland where out of a population base of

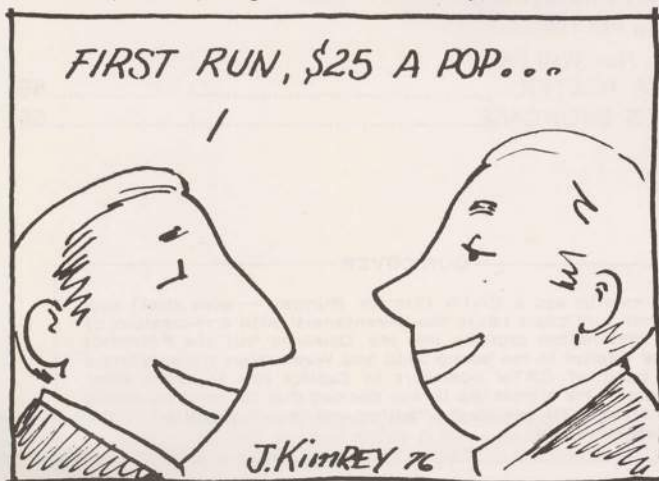

more than one million people the theater operator could reasonably expect to entice four or five thousand people into his 500 seat theater over a weeks time, but in downstate McConnellsville (population 2,100) attracting the same percentage of local residents to his theater for **Deep Throat** would be a financial disaster for that theater operator. The movie producers were desperate for audience, so they turned to shock-value movies that presented scenes that largely G-Rated television could not duplicate.

This left the small theater operator with virtually no product to show, and as a result, many theaters folded up and died in the 60's. At the time many blamed television for the demise of the theater, and perhaps indirectly it was to blame. But more directly, the quality of the remaining movie product, provided by the movie makers, was the culprit.

Were there not some good products left, movies which a family could watch? Yes, there were a few, of course. But there were so few that the demand for them increased dramatically, and with the increased demand up went the price. From \$25.00 per week the price went to \$200. to \$500 per week, and 70% of gross. Again, the \$200. to \$500. was a form of guarantee (although movie distribution contracts do not refer to these fees as guarantees), and if you did say \$1000 for the week in your theater with **Jaws**, the distributors and the motion picture producers got \$700 and left you with \$300. The \$200. to \$500.00 is **up-front money**, incidentally; theater owners pay this to the distributor even before they get their print.

Today there are still around 150 productions or releases per year from the 8 "majors." However there has been a new entry in the business in the past few years; a new breed of "independent producer" releasing G and GP features such as **Winter Hawk**, **In Search of Noah's Ark**, and wildlife adventure features such as **Alaska**. In the current year these new "independents" will turn out around 50 to 75 films. Now unlike the 8 majors who demand up-front money and a big chunk of your gross, the independents give the small theater operator two options. One is called the "four-wall contract," wherein the independent comes in and rents the theater for a day or two days and he pays a negotiated rental for the theater for his stay there. Rentals such as \$250.00 per night for a one-night stand are common for film features such as "In Search of Noah's Ark," in communities of a couple of thousand people. For this the independent sends in a man who brings the precious film-print, and the theater operator provides a projection operator. The independent collects all of the gate receipt money, and pays the theater operator his negotiated rate. The theater operator gets to keep whatever he takes in at the concession stand. As we said, that is one option.

The second option is when the independent offers you less guarantee money (such as \$100.) but offers you 25-30% of the gross. It is a gamble, of course, but then what isn't a gamble these days. In either case, the choice is the theater operators and win, lose or draw, he made the choice on his own.

CATA-torial continues — page 54

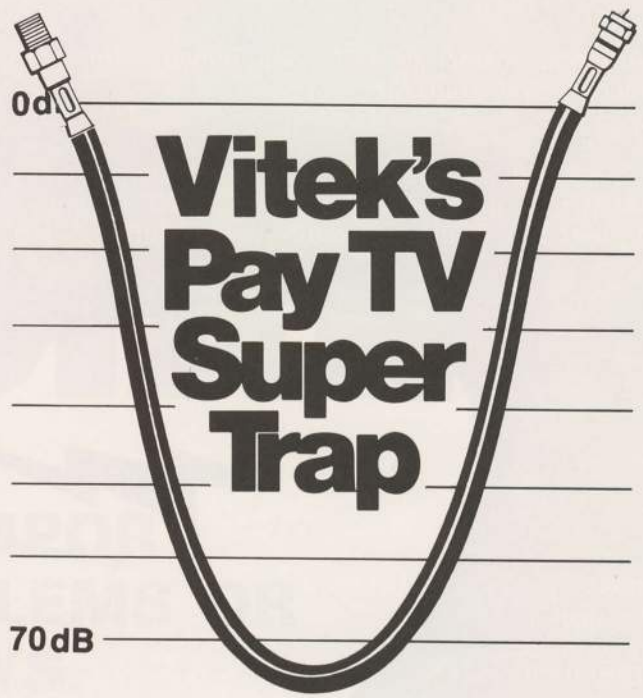

Our unique cable trap* looks and feels like ordinary drop cable ... but that is the only similarity!

The VITEK SUPER TRAP offers you:

- Fantastic durability (it can be dropped from a 200-foot tower)
- Blends-in with its environment (looks like the drop cable around its installation)
- Deep-notch depth for the same price (typically greater than 70 dB)
- A better job of eliminating R-rated audio complaints

For further information regarding our cable trap and for help in overcoming your Pay TV security problems, call or write to: Robert G. Geissler

VITEK Electronics Inc.
200 Wood Avenue, Middlesex, N.J. 08846
(201) 469-9400

VITEK ELECTRONICS, INC.

*Patent Applied For

TV RECEIVING EARTH STATION

- Antenna meets all FCC requirements for both receive and transmit
- Gain 51dB at 3.95 GHz. G/T of 26 when using GaAs FET pre-amp with 3dB NF at 20° elevation. Video S/N 52dB minimum with 34dBw EIRP
- Double reflector feed system for superior cross polarization discrimination. (Much better than prime focus!)
- Antenna erectable without crane
- Guaranteed system performance



ANDREW

Andrew introduces a new complete earth station . . . 10 metre antenna, LNA, receiver, connecting and pressurizing systems . . . plus transportation to site, installation and checkout if you want it.

More than 40 Andrew earth station antennas are now in service in the Canadian domestic satellite system of TELESAT Canada. 100 Andrew earth station antennas will be used in the Alaska Small Earth Station Program.

Call or write for complete information.

Andrew TV receiving earth stations are making pay TV pay in Aurora, IL; Ballanger, TX; Berlin, MD; Des Moines, IA; Erie, PA; Grand Island, NE; Hayward, CA; Owensboro, KY; Pompano Beach, FL; Manhattan, KS; Tulsa, OK. And there are 20 more Andrew units scheduled in the next few months. For the best quality pay TV reception via satellite at the right price, you should have an Andrew earth station, too!

ANDREW CORPORATION, 10500 W. 153rd St., Orland Park, IL, U.S.A. 60462 Telephone: (312) 349-3300
ANDREW ANTENNA COMPANY LTD., 606 Beech St., Whitby, Ontario, Canada L1N 5S2 Tel: (416) 668-3348
ANDREW ANTENNA SYSTEMS, Lochgelly, Fife, Great Britain KY5 9HG Telephone: (0592) 780561
ANDREW ANTENNAS, 171 Henty St., Reservoir, Victoria, Australia 3073 Telephone: (03) 460-1544
ANDREW ANTENAS LIMITADA, Caixa Postal 600, 18100 Sorocaba, São Paulo, Brasil Tel: Sorocaba 2-8900



CANADIANS!

**NO IMPORT
PROBLEMS OR
DELAYS.**

For high quality CATV products backed
by reliable service, order from...
COMM-PLEX ELECTRONICS LTD.

DISTRIBUTORS OF:

**CORAL • KAY ELEMETRIC • SADELCO • MICROWAVE FILTER •
TRIPLE CROWN ELECTRONICS • PHASECOM • TOMCO • MID
STATE COMMUNICATIONS • CCS HATFIELD • VITEK**

For Free Catalogue and Information
Call Your Comm-Plex Representative in Canada

Montreal
Tel: (514) 341-7440
Telex: 05-826795

Toronto
Tel: (416) 449-6263
Telex: 06-966599

Vancouver
Tel: (604) 437-6122
Telex: 04-354878

Halifax
Tel: (902) 423-7740

COMM-PLEX
ELECTRONICS LIMITED

An All Canadian Company

JULY 1976

Tomco total Standby Receiver

...the SR-1000

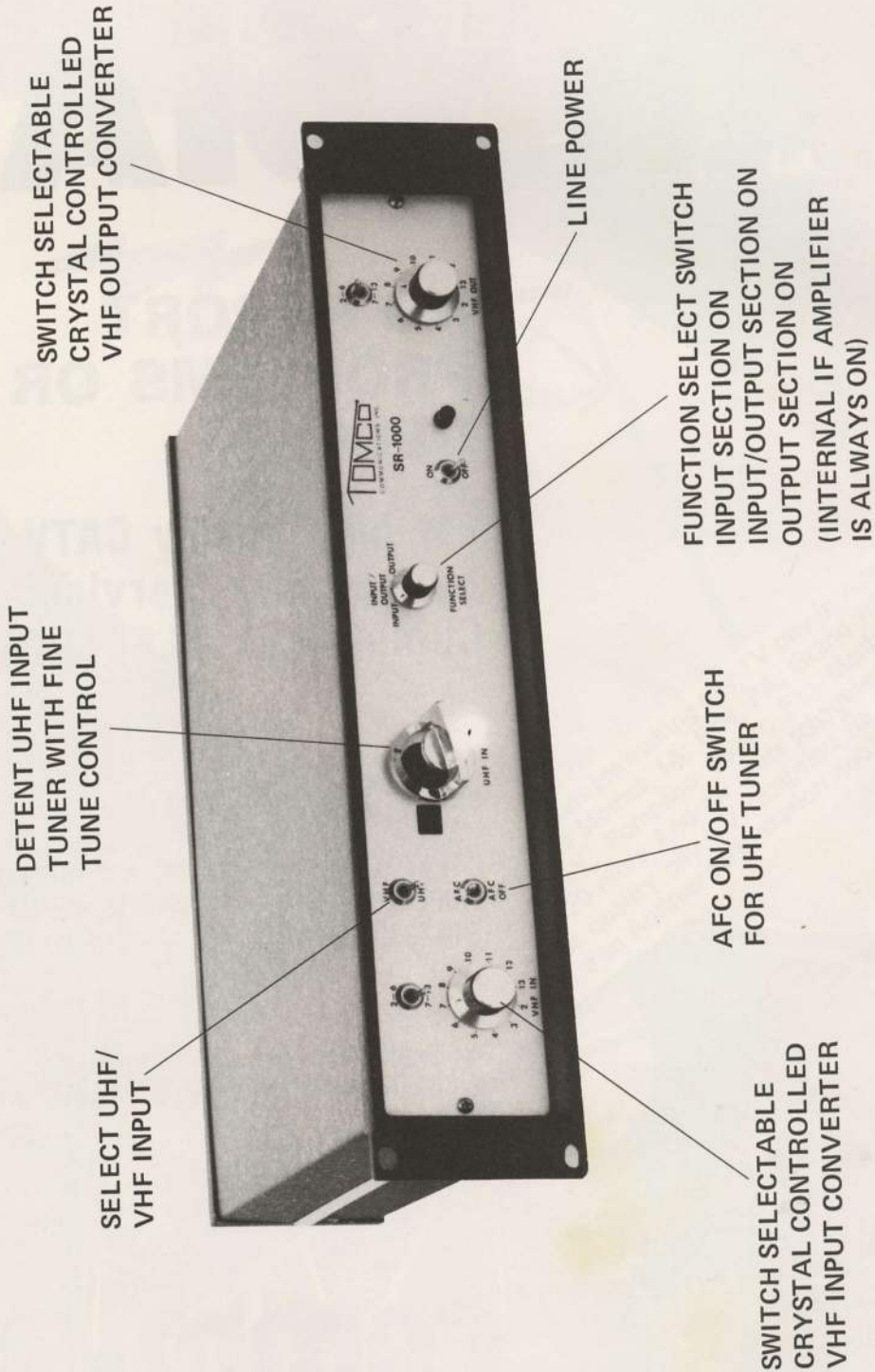

HEATH

Schlumberger

you can get MORE for your testing dollar!



NEW IO-4550 Dual-Trace DC to 10 MHz Scope

Has digitally-controlled time base, automatic triggering, extra bright trace and fast writing speed. A special TV position on the trigger select switch cuts off high frequencies for triggering on TV vertical frame signals. Shpg. wt. 31 lbs.

SO-4550,
Assembled \$25.00
IO-4550, Kit Form . . . \$79.95

IO-4510 Dual-Trace DC to 15 MHz Scope

Our best scope features vertical delay lines, 45 MHz typical trigger bandwidth, maximum sensitivity of 1 mV over full vertical bandwidth. The CRT has post-deflection acceleration for extra high brightness. Shpg. wt. 34 lbs.

SO-4510,
Assembled \$75.00
IO-4510, Kit Form . . . \$69.95

NEW SR-207 X-Y Input Recorder

More features and flexibility for the money! Built-in sweep, vacuum paper hold down, individually floating X and Y inputs with front panel controlled filters. Less than 1 second balance time. TTL compatible remote control for pen lift, servos and sweep start. Shpg. wt. 26 lbs.

SR-207, Assembled . . \$70.00

SR-206 Dual-Pen Strip Chart Recorder

Ideal for comparison uses—both channels have identical inputs and specifications. Uses disposable nylon tipped pens for distinct traces at any chart speed. Features 250 msec balance time, digitally derived chart speeds, full remote control capability. Shpg. wt. 32 lbs.

SR-206,
Assembled \$1395.00

Read all about our complete line of kit or assembled instruments in these two new catalogs...they're

FREE!

Our assembled instruments catalog describes the latest in quality, reliable instrumentation from Heath/Schlumberger.

Our Spring kit catalog describes over 400 kits you can build yourself for fun, for profit, for practical living.



Send for your copies today!

Heath Company, Dept. 310-19,
Benton Harbor, Michigan 49022

Heath Company, Dept. 310-19
Benton Harbor, Michigan 49022

TE-336

Please rush me my FREE Catalogs.

Name _____

Address _____

City _____ State _____

Prices & specifications subject to
change without notice.

Zip _____

CB INTERFERENCE — A NEW MONSTER RAISES ITS UGLY HEAD

PERHAPS A MILLION A MONTH

If you have been attending your state or regional CATV meetings of late, you have probably heard much discussion among system operators of the "new" CB interference problem, a problem created by the rapid growth of the FCC's Citizens Radio Service.

The problem is almost totally out of control, *and the FCC admits it.* And if you have not yet experienced it, you must be doing something very-very right. For hundreds of CATV system operators report they have problems with CB created interference that is literally driving them right up the walls.

At the springtime meeting of the Oklahoma CATV operators, an FCC person from the Cable Television Bureau was on hand to address the group. More than 50% of the discussion time was taken up by incensed CATV system operators asking *why* the FCC was *not able* to control CB users who were getting into every CATV piece of equipment from the headend pre-amplifiers to the customer's receiver in the home. The Cable Bureau type, who had advance notice that CB was going to be a major topic of discussion, was barely able to hold his ground, and when pressed to the wall finally admitted, "*Hey... this CB thing is out of control, and we admit it!*"

At another springtime meeting in Arkansas, a system operator from a small town in the southwestern portion of the state reported, "I am going to have to move my headend site into an area where CB'ers can't drive to with their cars. Every evening up to several dozen of these fellows drive the public road to my headend site and park under my 500 foot tower. From this elevated site, they talk a hundred miles in all directions, and they cremate my headend gear from the pre-amplifiers right down to the processors. This thing is going to cost me perhaps 50 thousand dollars to solve!"

CB began as a little used general purpose personal and business UHF radio service in 1947. At that time, there were a handful of 460 MHz region Class A and B CB channels allocated. Long ago FCC Commissioner E.K. Jett who pushed for a "public radio band for two-way communications,"

envisioned the day when "every citizen will have his own two-way radio." Jett, like many dreamers, was premature. But now some thirty years later his "dream" is forcefully close to reality.

In 1958, the FCC gave to CB *another* band of frequencies, the so-called Class D channels (23 in all) roughly 10 kHz apart from 26.965 MHz to 27.255 MHz. Then things started to happen. Rather than complicated, short-range UHF flea power sets, simple, mid-range HF "flea power" sets began to show up in the marketplace. For approximately 15 years after the 1958 opening of the 27 MHz Class D CB channels, CB went through fads and phases with up to perhaps 25,000 new licenses being processed by the FCC each month.

Then in the spring of 1975, a sudden boom in CB popularity occurred. Why it happened (and continues virtually unabated to this time) is of little concern to those of us affected by its boom status, although many within the CB industry believe the boom is largely the public's reaction to decreasing highway speed limits, almost universal use of CB by 18 wheel long haul truckers and a general increase in violent crimes against individuals. The fact remains that at the present time the FCC is receiving new license applications for CB at a rate of between 500,000 and 600,000 per month! That is some jump from barely 40,000 a month in late spring in 1975.

Until the recent boom growth of CB came along most of the CB users had some basic interest in electronics, or if no basic interest, at least an inquisitive nature about what happened when they pushed the microphone button. But the recent boom has seen a whole new influx of users; people who largely are intrigued by the convenience of mobile communications and having somebody around to "chat with" at virtually any spot in the USA. *They don't care* about watts and wavelengths and adjacent channel splatter. *They just want to communicate.*

Now the pre-boom CB'ers were largely serious talkers or serious hobbyists. The serious talkers had real business or real bonafide personal com-

BUT IS CB ALL BAD?

One might get the impression from this extensive CATJ report that all CB is bad. Not so. CB is potentially one of the most useful and productive tools to ever appear in the hands of the typical American consumer. But like any tool, it has the potential for mis-use and where the potential exists there are those who will mis-use it.

There have been thousands (if not hundreds of thousands) of examples of CB saving lives, protecting property, moving traffic, providing much needed and often the only form of communications.

CB is neither all good nor is it all bad. It is like any human endeavor and that means it has good and bad points. Those who use it well and wisely have our commendation; those who mis-use it... well, they are what this report is all about.

munications to transmit. The serious hobbyists were largely trying to emulate the more advanced ham-hobbyists, without the hang-up of getting a ham license (which unlike CB, requires written and Morse Code proficiency testing prior to license grants). The pre-boom serious talkers were probably largely obeying the CB regulations, they regarded CB communications as important if not essential to their daily affairs. The pre-boom serious hobbyists were largely illegal, that is operating with antennas or power amplifiers or both which exceeded the limits placed on CB by the FCC.

The pre-boom serious talkers seldom got into trouble, or their neighbor's television receivers. Most CB transmitters, straight from the factory and untampered with, won't cause *much* in the way of interference. The pre-boom serious hobbyists were capable of wiping out TV reception for blocks around, but *because* they knew they *were* operating with illegal power/antennas/etc., and could be easily traced if they didn't watch their step, they took proper measures to see that their clandestine operations did not cause any more interference than the state of the art would allow.

All of this was pre-boom, and all of this involved either serious users who obeyed the law, or serious hobby-oriented users who disobeyed the law *and worried enough about being caught* that they installed things such as TVI (television interference) filters to protect themselves. Then the boom hit.

The new user is "intrigued" about *the ability to communicate*. He is largely unaware of the meaning or intent (or even the existence) of FCC rules governing his operations, and he knows from other users that the FCC simply does not have the manpower to trace down even a small fraction of those individuals who choose to defy the law. So where the pre-boom serious hobbyist spent a lot of time (and money) worrying about being caught with his 500 watt amplifier warm (the CB rules allow no more than 5 watts DC plate power input to the final RF power amplifier stage of the transmitter), the new user worries not much about anything. Except perhaps being able to "talk over" anyone else "on the channel."

At an FCC sponsored meeting held in Washington April 30th, the FCC's CB watch dogs outlined the scope of "their" problem to approximately 100 industry people who gathered in the first of four PURAC (Personal User Radio Advisory Committee) meetings. CATJ and CATA were on hand to represent the CATV industry and to contribute our own industry data into the "data bank" now being collected by the FCC on the subject.

Item: At the 24 FCC Field Office Bureau monitoring stations there are 400 employees. Of this 400 approximately 100 people are trained to track down and cite violators of FCC rules. These 100 personnel must cope with *not only* CB problems, but every other user of the spectrum from the Hams to the broadcasters, public safety people to the

point to point microwave users...and on and on. There are roughly 200,000 user *licensed* transmitters for *each* of the 100 FCC field-capable people.

Item: For many years the FCC routinely conducted FOB monitoring of all services including CB. The Commission *used to go looking* for violations and violators. The FCC's FOB growth has not kept up with general licensee growth in services other than CB, and CB monitoring at FOB facilities has now been stopped. The FCC *now* depends upon a special set of CB enforcement teams (three in all nationwide, not unlike the SWAT group) but mostly it depends upon complaints to their offices to "trigger" investigations of CB mis-use.

Item: FCC FOB telephones are jammed beyond capacity. In a recent week in April, the Dallas FCC office engaged the services of the telephone company to record the number of *attempted-calls* that did *not* get through. In the *one* week period, that *single* FOB facility did *not* answer more than 2,000 calls because the existing telephones were busy.

Item: A special crash training course for FOB personnel (i.e. everyone who works there) is underway to try to train every secretary, every file clerk, every-one who gets an FCC paycheck to be able to answer approximately twenty typical calls which FOB feels will handle 95% of the CB call-ins.

Item: A special emergency appropriation of around \$350,000. has been adopted by Congress to help get additional people into FOB offices *just to answer the telephone*.

We could go on, but you should get the point. The FCC is more tied up in knots over the CB program than anything that has ever hit this federal agency. *You should not expect any help from the FCC regarding CB*, because the manpower is simply *not* available.

In short...if you are having problems with CB in your community look to your own community resources to solve the problem(s).

Item: The Garland, Texas City Council has adopted a local ordinance which makes it a misdemeanor for anyone to "violate the privacy of another" by transmitting radio signals which are picked up on a second party's radio, television or hi-fi set.

In Garland the local City Council asked the FCC's Dallas FOB to investigate a series of TVI complaints, local citizens who found their Rhoda and Johnny Carson reception marred by "That's a Big Ten-Four Old Buddy" night in and night out. The FCC finally did send an FOB team out to Garland (a suburb of Dallas), probably because the City Council had gotten into the act. They had previously ignored ("sorry — we have no personnel available..." requests for help from the *citizens* affected. After investigating, the FCC team pronounced the Garland CB'ers "clean" and blamed the inadequate filtering in the home

viewers radio, television and hi-fi equipment. Frustrated, the City Council adopted their "Anti-Noise" ordinance, and it is now illegal in Garland for a CB'er (or anyone else) to "blast through" a neighbor's electronic appliance with annoying voice (or other) transmissions.

The FCC says this one will end up in court *when they find the time* to "sue" the city.

Item: The Tulsa, Oklahoma city council, similarly disturbed by TVI complaints, decided that all private transmitting antennas could be no more than 29 feet above ground. Someone had originally suggested that the ordinance limit all transmitting antennas to a height no more than 5 feet "*below ground*" (!).

There is excellent engineering data which suggests that no small portion of the TVI/BCI/hi-fi may actually be the fault of *poorly designed* consumer electronic equipment. Much of the interference *can be* traced to something known as "audio rectification," a phenomenon that occurs when a strong RF field (within a few hundred feet of a 5 watt legal CB transmitter, the field is strong enough for this problem) *surrounds* a receiver. The receiver has any number of "rectifiers" that don't know they are rectifiers, everything from a poor solder joint in a speaker lead to an audio amplifier stage (usually the first stage following the detector in the receiver; and they just naturally rectify anything strong enough to saturate it) can be at fault. Given the opportunity . . . and there are millions of them . . . audio rectification is a plague which only improved consumer receiver design will cure.

One would think that consumer receiver manufacturers would spend a few hours time and a few pennies a receiver to solve this problem. One would think wrong on this count. Where every penny of overhead multiplies into dollars in the marketplace there has been (and continues to be) an industry-wide reluctance to clean up the receivers.

Item: Two pending pieces of legislation would *force* the receiver manufacturers to clean up their designs. HR 7052 and S 3033 are awaiting action in the present session of Congress, either one if passed and signed into law would create federal guidelines for any consumer electronic equipment to be shipped in interstate commerce. The guidelines would largely solve the (majority of) defective receiver designs, at least for *new* receivers.

There is also excellent engineering data that suggests that a large amount of the basic TVI (in particular) is caused by poorly designed TV receiver input filter networks. A solution to this one is also included in HR7052 and S3033; they would require receiver manufacturers to equip all new receivers with high pass filters so the 27 MHz fundamental frequency (i.e. Class D) is filtered out at the receiver's input end ahead of the tuner.

The CB TVI problem is a complex one. At the



HARMONIC CREATES HERRINGBONE BEAT—Harmonic signal falling into TV channel 2 creates herringbone "film" over picture; ratio of harmonic signal level to channel 2 signal level determines "degree of blanking" of TV picture.

present time CB transceivers have FCC specs which determine how far down (i.e. how much attenuated) the second and third (etc.) harmonics of the fundamental 27 MHz frequency shall be. A transceiver that does not meet this "dB down" criteria is not *supposed to get* FCC type approval, nor is it *supposed to be sold* on the market without such approval.

Unfortunately, perhaps, the spec relates only to second and third harmonic frequency energy *as measured at the RF output coaxial connector* on the back of the CB set. There is recent evidence, some of it developed by CATJ as part of our PURAC contribution, that the CB transceiver may radiate more potent second harmonic (which falls into TV channel 2) and third harmonic (which falls into TV channel 5) energy from *the metal chassis of the transceiver itself* than it does through the output RF connector on the back of the transceiver.

To trap the 54-55 MHz energy (second harmonic) and the 80-82 MHz energy (third har-

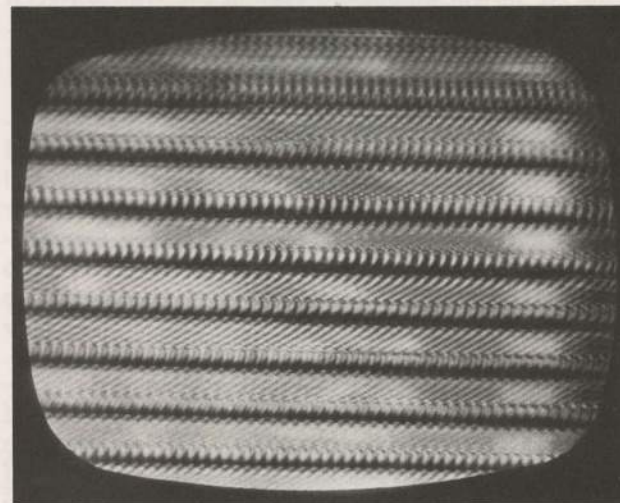

AUDIO BARS WITH HERRINGBONE—When CB'er "modulates" his transmitter, herringbone film may be modulated by horizontal black and white bars that vary at audio (speech) rate.

monic), the CB manufacturer installs a set of *tuned traps* between the output RF amplifier in the transmitter and the RF output connector. *The traps carry the second and third harmonic energy to chassis-ground.* But the unshielded chassis is seldom connected to an earthen or driven rod ground, so it becomes a "carrier of" 54-55 and 80-82 MHz energy. And connected to the chassis are any number of wires and cords and cables, plus the metal surface area of the chassis itself. They all take this headed-for-ground but often-diverted energy and *they radiate it into the air.* In some circumstances, there are resonant or near-resonant wire leads which when combined with the metal chassis on the transceiver make dandy 54-55 or 80-82 MHz antennas. So the second or third harmonic energy may not get to the CB's outdoor 27 MHz antenna, but they radiate throughout the neighborhood nonetheless. Some may even get into the household wiring circuits, by radiating backwards up the AC line cord from the transceiver. Then the whole house (wiring) becomes a gigantic sometimes resonant / sometimes non-resonant antenna for channel 2 and/or 5 television interference.

Item: Jeff Young of the FCC's Field Office Bureau headquarters staff in Washington is currently overseeing a nationwide FOB program to attempt to classify by frequency-of-occurrence the various forms of and causes of CB TVI. In markets such as Denver, Seattle, Buffalo and others, the FCC is going into the field with portable measurement equipment (including spectrum analyzers) to try to piece together some hard data on the problem.

All of this assumes that the CB transceiver is operated properly, and that it has *not been tampered with* by some half-talented person since it left the factory. Sadly, this is very often not the true situation.

CB'ers want to be able to talk. They want to *talk over* anyone else on the channel, and they are anxious to get *more* performance out of their sets. There has sprung up a small army of know-not-very-much enthusiasts who for a small fee (or for the spirit of CB friendship) will "modify" a fellow CB'ers transceiver so he gets "more power out" to his antenna. Some of the CB manufacturers have "cooperated" by designed into their transmitters voltage divider networks and by using output amplifier stages that are *capable of* operating at 10, 20 or even 50 watts output power. Then in the transceiver service manuals (or the customer instructions) these "helpful" manufacturers print in big black print "DO NOT CUT WIRE SEVEN AT POINT A OR THIS TRANSMITTER WILL OPERATE WITH 20 WATTS OUTPUT." The world is full of people who will cut that wire.

Another favorite of the "let's get more juice into my antenna" crowd is one which should be of major concern to every CATV operator with a channel 2 or 5 off-air or on cable. The TVI filter (this tuned network traps second and third harmonic

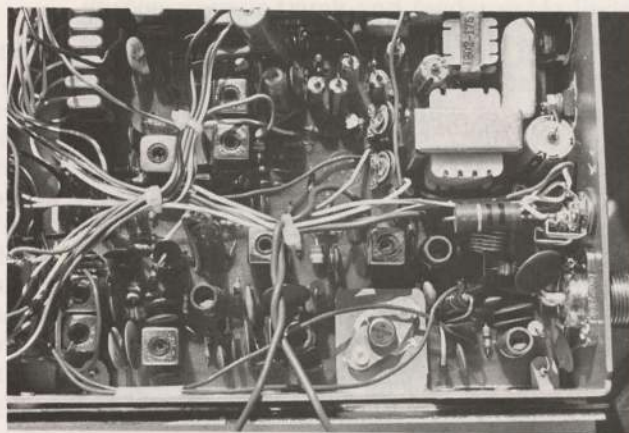

TYPICAL CB TRANSCEIVER TRANSMITTER— RF generation section sits on one side of full transceiver board progressing from low level stages through final amplifier (left to right).

energy to the *non-ground* chassis ground) naturally soaks up *some* RF output energy. Only it soaks up the *unwanted* (and not useful at 27 MHz) energy on 54-55 and 80-82 MHz; *not 27 MHz.* But try to explain *that* to a CB'er who has "discovered" that *when* he cuts the TVI filter wire between his output stage and his output coax connector that his *indicated power output* (which he lovingly measures with a \$29.95 "wattmeter" every chance he gets) goes *up* "perhaps a half a watt." To the CB'er, a half-watt is a half-watt. He cares not and understands less that it is a half watt of RF power *not on 27 MHz* but combined on 54-55 and 80-82 MHz, which he is now measuring with his *broad-band* (i.e. not frequency selective) wattmeter. So bang...there goes the TVI filter which the manufacturer originally installed and tuned to *cut down* (to FCC spec) the 54-55 and 80-82 MHz interference — creating energy.

Item: According to the FCC's Jeff Young, the number of complaints to the FCC will top 100,000 during 1976 alone. The rate of increase during the past year, while astronomical has *not* kept pace with the even more impressive rate of growth of CB licensing. The FCC feels that the non-linear increase is largely attributable to the fact that people are *unable to get through* on the

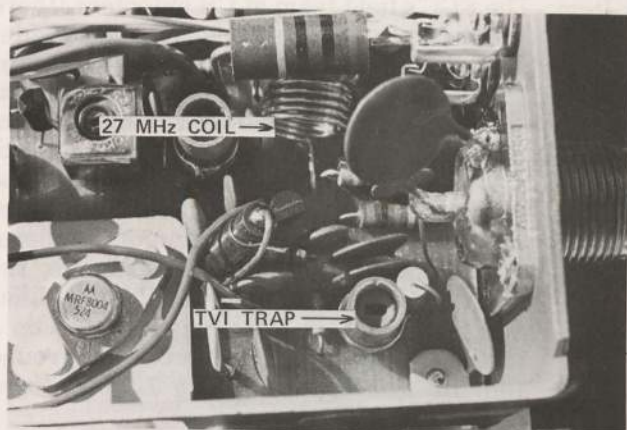

NO SHIELDING EVIDENT—RF amplifier (output) stage with 27 MHz tuned circuit (large coil marked). TVI trap (marked) is unshielded and RF "trapped" is allowed to "float freely" with(in) loose fitting outer metal case that is anything but radiation proof.

telephone to their local FCC office (!).

All of the preceding is based upon the assumption that the CB transmitter is the basic five-watt transceiver which anyone can walk into a supplier and purchase for a hundred dollars or so. It assumes that the user uses the transceiver either stock, or at worst case by doing nothing more drastic to it than (1) cutting a "do not cut wire" that boosts the output power by 3 to 10 dB, or (2) bypassing the built-in TVI filter that reflects in another half-watt or so of RF power on the in-line wattmeter (even if not on 27 MHz). These are "more or less" *manageable problems*, and given sufficient time and money the FCC will *eventually* prevail on these people.

Then there are the real mavericks in CB, the people who openly flaunt the law, who care not about any rules or regulations, and who are in CB because it is a "fun hobby" that lets them talk (illegally it turns out) to other similarly inclined people all over the United States and a good portion of the world.

The 27 MHz band used to be a world-wide type of amateur radio band. On given days and at given times, the ionosphere sends 27 MHz signals far and wide. When the hams had the band (prior to July 1958) it was not unusual for a ham in Illinois to carry on a "round table discussion" with a ham in South Africa and another in Hawaii, *simultaneously*. The 27 MHz band still has the *same* long-distance characteristics. And when a CB'er with a hobbyist bent starts hearing fellows just like him thousands of miles distant he "naturally" *wants* to talk with them. *Being able* to talk over thousands of miles *is its own addiction*.

To make the most of such conditions, the serious devotee of *this aspect* of CB boosts his transmitter and builds a bigger antenna. The FCC limits transmitter power to five watts, and antennas of an omni-directional nature (i.e. ground plane) to 60 feet in height. For directional antennas (i.e. beam antennas such as Yagi-Uda types) the limitation is 20 feet above the roof of the house. These two rules are bent liberally by CB'ers who are "into talking skip" (skip is the radio operator's phrase for long distance communications).

Item: The FCC's field team of CB enforcers (there are presently three such teams nationwide) recently moved into the Birmingham, Alabama area to crack down on the illegal power and antenna users of CB in that area. Before they were all done with approximately one week's monitoring, they had the goods on more than 60 operators who were operating with generous amounts of illegal power and antennas. In one example, the operator had a 10,000 watt (!!!) amplifier and four five element beam antennas on a forty inch face tower 200 feet above ground (!!!). *He was approximately 140,000 times over-power.*

If a little five watt transmitter into a low (or no) gain ground plane can cause TVI consider what a 10,000 watt transmitter and 15 dB gain 200 foot

tall antenna can do.

This type of CB'er is perhaps not a CB'er at all. There has been, in the last year or so a *dramatic* increase of use of non-CB frequencies immediately *adjacent* to the 27 MHz CB band by people who have *no license at all*. These people are purchasing Japanese built 100-500 watt SSB (single side band) transceivers intended ostensibly for the amateur radio market, and simply "sliding" off of the 23 assigned CB channels to create *new "channels"* and a whole "new radio service." Their whole *modus operandi* is to have a hobby talking to as many people as they can in as many far away places as they can find. And whereas the mis-user of the 23 CB class D channels can *usually be traced* sooner or later by their CB operating habits (and their infrequent use of call signs issued by the FCC), this *new breed* who call themselves "side-winders" (a ham type phrase for sideband operators) are even assigning *themselves* their own call letters.

Item: Overheard in early June at the CATJ Lab on a receiver tuned just above the top of channel 23 (a frequency assignment *not* allocated to CB):

"USA 2107, this is USA 1414 in Miami, Florida. You are rock solid here old man. I'd sure like to have a piece of wall paper from you there in Kansas. The rig here is 400 watts driving a pair of five element beams at 100 feet...how's the copy there in Kansas?"

Interpretation? Through some clandestine "club" these people have *assigned themselves call letters* that begin with "USA." The fellow in Miami is operating a 400 watt transmitter and a 12 dB gain directional array talking with another similar enthusiast in Kansas, some 1300 miles distant. *Neither* has an FCC license, both are operating on a frequency reserved for the business radio service, *and neither one really gives a damn!*

Item: The FCC's Amateur and Citizens Bureau attorney Dick Everett told the assembled PURAC group in Washington on April 30th, "At a recent CB gathering in Ohio we were fascinated to find that the patently illegal "Sidewinder" bunch was on hand with *displays* of their long range contacts *and their equipment*. One of the officers of their national organization *boasted to us* that they now had more than 40,000 members nationwide, and that the typical devotee operates a 200 watt rig with stacked Yagi antennas. They even felt *they were better than the CB crowd* because *they were* all using single sideband and operating with *more* power than CB'ers typically use. They seemed virtually unconcerned that *they were operating illegal radio transmitters* on frequencies *not assigned* for that use, and that they did *not* have any radio licenses at all!"

The FCC is experimenting with a new FOB enforcement tool, a homing type of direction finding

system. The unit is installed in a vehicle and with a dashboard display the operator simply follows digital instructions displayed before him. He tunes in the signal he is trying to trace and then starts driving. The dashboard display reads out simple English instructions such as "turn left," or "back up and turn right," and so on. With this automatic system, an FOB inspector can locate an unknown transmitter source as quickly as he can drive to the site. Gone soon will be the age-old practice of having to get two or three or four direction finding loop units to "triangulate" the location of an unknown transmitter source. This makes every similarly equipped FOB vehicle a one-car triangulation "team," which will greatly speed up locating these pests.

But if there are 40,000 "Sidewinders" out there (and growing daily), it will still take a long time to close sufficient of them down and take them to court where jail sentences and large fines can be administered that the balance will give up and go and get an amateur radio license.

In a nutshell, the CB boom is one great big can of worms. There are many more problems than there are solutions. And to attempt to *simplify* the problem is to fool one's self as to the probable solutions. We felt this background was important before we got into the specific CATV problems with the CB monster, because to tame the beast you have to understand how big he is, what he eats, and where he deposits his dung.

Where Are We Getting It?

The CATV system is potentially one of the most vulnerable *receiving* systems in the country today, vis-a-vis CB interference. The places where the CB'er can get into our pictures (and sound) are numerous. For example:

- (1) *The headend.* Ask Jack Ryan of Dierks, Arkansas about his problems with CB'ers parking under his big tower and talking to distant points. Ask Jack about trying to provide cable-usable signals on a -20 dBmV channel 2 signal when there are a dozen 27 MHz transmitters, some with 50 to 100 watts of power, *parked under his tower.*

When there is *that much* 27 MHz RF that close to the CATV receiving antennas, the CB problem is not simply second harmonic (on TV channel 2) and third harmonic (on TV channel 5). It can just as easily be fundamental blocking or overload. Put 20,000 to 100,000 (+) microvolts of 27 MHz energy across the input terminals of a low noise, high gain channel 7 pre-amplifier, and watch what happens. No amount of CATV pre-amplifier filtering is likely to keep the fat 27 MHz signal from cross modulating the pre-amplifier. We'll visit this in detail as we go on with the subject.

- (2) *The CATV plant.* Here we have mile after mile of supposedly highly shielded "antenna wire" strung all over town. The center con-

ductor on your trunk and feeder cable lines is one very fine "long-wire" antenna. Only it is "shielded" by the jacket on your cable. If your jacket is good, none (or very little) of the fat 27 MHz signal from a local CB'er is going to get into the CATV plant lines. But if you have some of the old Arthur Baum special cable still in use, or you have a bum (non-RFI tight) connector here and there, the 27 MHz energy can and will get into the CATV plant. Even if the CB'er has no harmful amount of 54-55 or 80-82 MHz energy present, if there is a fat amount of 27 MHz energy present, what do you suppose happens when the high level 27 MHz signal climbs through a non-secure cable shield and ends up at the input of a trunk or feeder amplifier?

Uh-huh. It is (pre-amplifier) cross-mod time all over again. And we will have more to say about that also.

- (3) *The CATV drop.* If there is a point of maximum vulnerability, this may prove to be it. The drop cable is often brought on "special." That is, can you get it for \$27.00 (or less) per thousand delivered? *How much* shielding? *What type* of shielding?

Too often, nobody *really* cares. Because until this CB thing came along, there were seldom (if ever) sufficient quantities of strong local RF sources which could potentially impregnate our drop cable shielding to bother us that much.

We'll have a great deal more to say about this.

- (4) *The customer's receiver.* Theoretically, this is *not your problem*; unless it can be shown that *you are causing* the problem by providing the customer's receiver with a "long wire" antenna "disguised" as a cable drop. If you are force-feeding the local 27 MHz energy into the customer's receiver with your improperly selected drop cable that was also improperly installed, you have a problem that you cannot duck.

Ditto. We'll have much more to say about this one.

Before we get deeply into our own unique CATV problems with the CB monster, let's review briefly the fundamental points where a CB (or other local) transmitter might innude a *single* receiver. It matters not, for this discussion whether the receiver is connected to a CATV drop or to its own antenna.

- (A) *Fundamental overload.* The CB transmitter is simply so close to the TV receiver that it pours hundreds of thousands of 27 MHz microvolts into the TV (or FM) receiver front end. Once present at the input to the receiver, the receiver either folds up and quits (i.e. blocks), or, it tries to fold up and quit. If this is the *whole* problem, it is fairly simple to solve. See diagram 1.

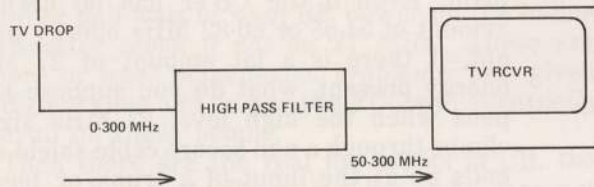
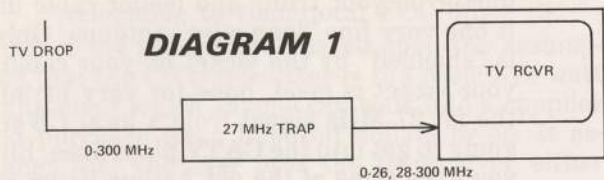
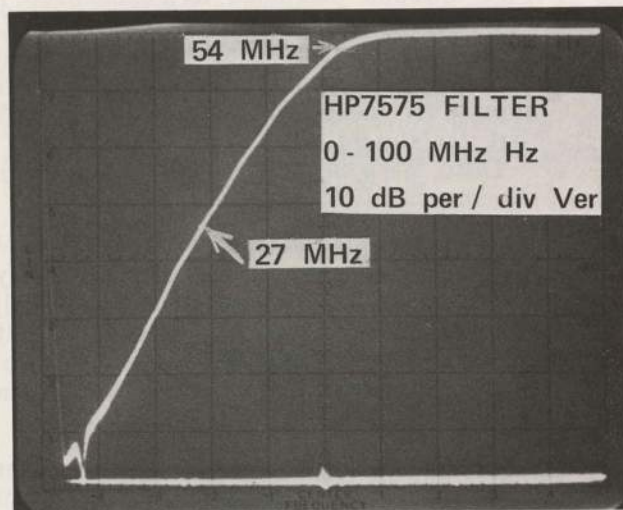
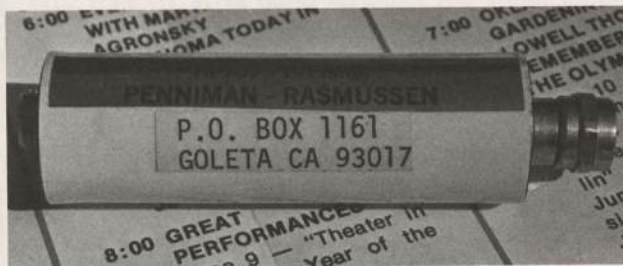

DIAGRAM 1A

The solution is to trap out the fat 27 MHz signal before it gets into the TV tuner. You can do this with an in-line 27 MHz trap (1-A) or with a device known as a high-pass filter. The high pass filter is not unlike the RMS CA 2600F matching transformer/filter described editorially on pages 27-29 for April's CATJ. Only where the CA 2600F creates most of its "notch" around the TV receiver's i.f. range, the trap / filter in *this* case would attempt to center maximum attenuation at 27 MHz.



Recently an outfit called *Penniman-Rasmussen* (P.O. Box 1161, Goleta, California 93017) announced the availability of a special 75 ohm high pass filter (model HP7575) which is designed for CATV system use. The unit (see photo here) is encapsulated in an EMI (through-radiation) shield that gives itself 50 dB of through the case rejection (to avoid direct pick up of 27 MHz by the HP7575

unit itself). Essentially, the HP7575 is a constant K filter constructed along semi-stripline techniques. The unit has between 28 and 40 dB attenuation in the 27 MHz range (see spectrum analyzer photo supplied by the manufacturer). The linear-line filter has even greater rejection at lower frequencies, and descends to approximately zero dB *thru loss* at TV channel 2's video carrier frequency. The unit would install in-line with the cable drop, at the subscriber's end of the drop, just ahead of the matching transformer.

There are similar filters around, but to the best of our searching none are 75 ohms input and output (which is what we need for CATV). One manufactured for years by the R.L. Drake Company (540 Richard St., Miamisburg, Ohio 45342) is the TV-300-HP which is 300 ohms input and output. Advisably, *any* 300 ohm version should be installed directly on the TV tuner's 300 ohm pigtail lead *inside* of the receiver. This is at the tuner end of the short (but often not short *enough*) piece of 300 ohm twinlead that extends from the receiver's back-of-set "antenna terminals" to the tuner input. (This "short" piece of twinlead often is *long enough* to pick-up considerable 27 MHz signal, and when the twinlead does such a dastardly thing, no amount of filter on the cable drop itself is going to solve the problem, the 27 MHz pick up is *after* the filtering!) This all may suggest that in extreme cases the TV cable drop (with HP7575 filter in-line) should go directly to the TV tuner's 75 ohm terminals *bypassing the 300 ohm flatline*.

Another equally potential cause is the ungrounded status of the TV (leadin/cable) drop. In a CATV installation the drop cable is supposed to be grounded (i.e. shield bonded to earth driven rod) at the entry to the home, according to many state electrical codes and an even larger number of municipal codes. Honestly, very few *are* so installed. The original intent was to "protect" the cable connected receiver from "dangerous voltages" that might get fed into the home via the sheath-shield of the drop cable; voltages from local AC sources which accidentally short to the CATV feeder line(s), or, horror of horrors, lightning. The CB interference situation may be *the best reason of all* to ground (bond) cable drops at the home entry, for *if* the shield is acting as an antenna or inductor for the CB transmission, grounding it at the entry to the home sure isn't going to hurt!

Finally, in the fundamental overload department, not all TV sets need to get blocked directly, some get it indirectly. Suppose you have a strong 27 MHz signal in the neighborhood, and a strong off-air channel 4 TV signal. Both are present *at the input* to the TV receiver. If both are really strong the 71.75 MHz channel 4 audio carrier *minus* the 27 MHz CB signal equals the mid-range of the TV receiver's i.f. (around 44.75 MHz). Therefore, given the right combination of local off-air signals and a 27 MHz signal, there can be produced in the front end of the TV receiver (i.e. the tuner) an undesired i.f. signal that flows nicely into the receiver i.f. And, the cure?

Get rid of one of the two signals that is mixing to create the i.f. degradation. In this case, the same high pass filter will or should do the job, simply because it attenuates the 27 MHz portion of the two-carrier-mix, thereby leaving the TV signal with nothing to beat and mix with in the receiver tuner. And absent that, there is no undesired i.f. product.

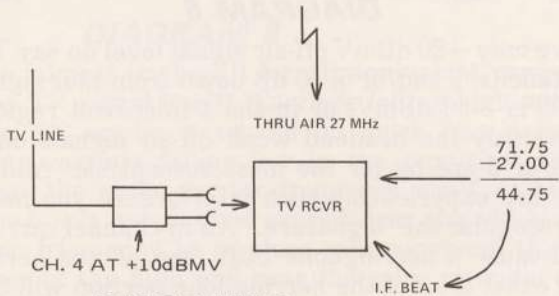

DIAGRAM 2

(B) *Audio rectification.* If the CB signal gets into the innards of the receiver proper (whether through a CATV drop cable or directly through the air), it stands a good chance of force-rectification in the receiver's audio stage(s). The first audio amplifier in a receiver (typically called an audio pre-amplifier) is usually a fairly high gain stage. In a tube type receiver, the first audio stage grid and cathode form a "diode" of a sort which thinks it is a rectifier, in the presence of a strong RF signal (from any source). In a transistor receiver virtually any of the *junctions* in the audio pre-amplifier stage can be made to function as a diode to rectify the strong RF signal.

Once the signal is rectified (i.e. turned from RF into audio) it flows onto the speaker leads going through whatever follow-up amplification stages there are present.

Solutions to this are shown here in diagrams 3 and 4. In the case of the tube type receiver, a pair of disc ceramic capacitors and a 75 k resistor are added to the first audio amplification stage. In the case of the transistor pre-amplifier you may be able to get by with a single disc capacitor from the base of the stage to ground. The 250 pF capacitor acts like a shunt to ground for the 27 MHz RF energy, but the small capacitance passes the audio signal essentially unaltered. If that does not prove adequate you

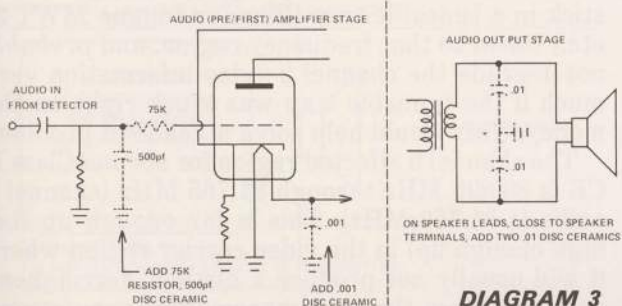

DIAGRAM 3

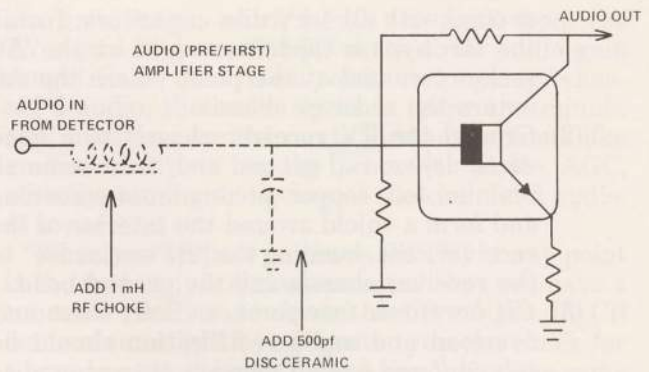

DIAGRAM 4

can add a 1 millihenry RF choke in series with the detected audio line to the base of pre-amplifier stage (along with the 250 pF capacitor). At audio frequencies the 1 mH choke has around 31 ohms reactance at 5 kHz, while at 27 MHz this looks more like 200K ohms.

The audio stages for the receiver are typically located on their own modularized board, interconnecting from the i.f. and detector with a shielded audio cable. The shielding on the audio cable may be suspect as a pick-up "antenna." The typical audio cable might be just fine for audio frequency shielding, but for RF integrity it leaves much to be desired.

Finally, if you find none of this helps, but you are certain-sure that what you have is audio rectification (characterized by the voice coming through regardless of the channel you are tuned to, and no or very light video interference), try one or both of these tips:

- (1) Sometimes the AC lines will act as an antenna-conduit for the non-desired (CB) signal, feeding the CB RF into the set via the AC cord attachment. In this case bypass both sides of the AC line to the chassis

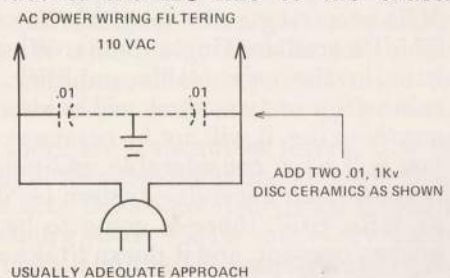
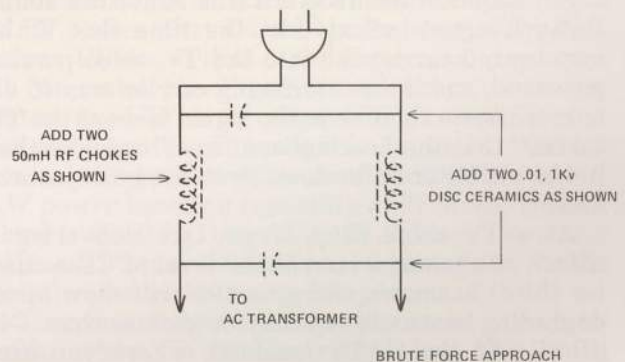

DIAGRAM 5



ground with .01 1 kV disc capacitors. Install the RF bypass capacitors right at the AC socket terminal at the point where the AC enters the receiver chassis.

- (2) Ground the TV receiver chassis to a good earth driven rod ground and, take some aluminum foil, copper or aluminum screening and form a shield around the interior of the receiver case, bonding the "RF enclosure" to the receiver chassis and the ground bond.
- (3) *CB harmonic interference.* Both front end overload and audio rectification should be solved *if and when* Congress gets around to adopting HR7052 and/or S3033 (*need we suggest that every CATV operator should be writing letters favoring the early passage of these bills?*). That won't cure the problem for the nearly 300,000,000 TV, AM and FM receivers and hi-fi sets already in the hands of the public, but it will *gradually* help as the older sets are discarded and the newer ones replace them in America's homes. But CB harmonic radiation, on-or in channel 2 and channel 5 *is another can of worms.*

The typical CB transceiver has 60 dB of second harmonic suppression, at least it is supposed to have this attenuation to be "legal." And the typical CB transceiver puts about 4 watts of RF transmitter power into the coaxial line driving the antenna. So we are 60 dB *below* 4 watts at 54-55 MHz. Now if at our receiving location there is 100,000 microvolts of 27 MHz energy, we can reasonably expect the 54-55 MHz energy to be 60 dB below that level (overlooking different "receiving antenna efficiencies" for the moment). That means we would have 100 microvolts of 54-55 MHz energy, quite a bit when you stop to think about it. Now getting 100,000 uV of "RF field" from a nearby 4 watt output 27 MHz transmitter is probably all but impossible unless you have a tuned-to 27 MHz receiving antenna within say 100 feet of the 27 MHz transmitting antenna. Whatever it is you have in the area (cable amplifier, cable lines, a cable drop or two, etc.) will seldom be a 27 MHz *anything* (i.e. it will not be *resonant on 27 MHz*), so you will have considerable *additional attenuation* because your receiving system is "de-tuned" from 27 MHz. Still, there is going to be *some* 27 MHz energy present, and it doesn't take *much* to create a herringbone pattern on a receiver.

Original tests conducted by the ham's national organization in the 1950 era (the American Radio Relay League) indicated at the time that if the non-desired carrier fell into the TV video portion passband, and if the interfering carrier was 40 dB or more down relative to the signal level of the TV carrier, that the herringbone "beat" would either not be visible or so far down as to not be objectionable.

At a TV cable drop, if you are delivering 0 dBmV on channel 2 (and 5) the level of CB second (or third) harmonic energy which will show up as degrading beats will typically be greater than -40 dBmV. At the CATV headend, where you may

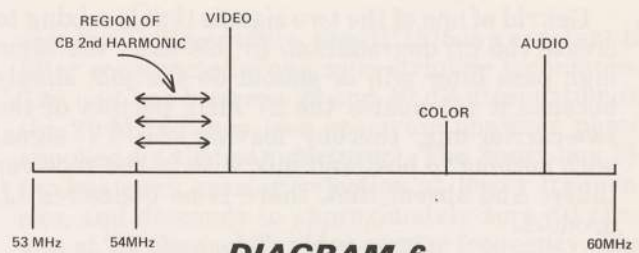

DIAGRAM 6

have *only* -20 dBmV off-air signal level on say TV channel(s) 2 and/or 5, 40 dB down from *that* signal level is -60 dBmV, or in the 1 microvolt region. Obviously the headend weak off-air signals on 2 and/or 5 are by far the most susceptible. And if you are experiencing such interference you need to recognize the "signature." An in-channel carrier will cause a herringbone beat (see photos here); the exact *level* of the herringbone portion will depend totally on the ratio between the TV carrier and the harmonic signal. The *pattern* or make-up of the beat will depend upon the frequency relationship (i.e. frequency separation) between the TV carrier and the CB (or other) harmonic signal. Typically, the herringbone beat will come and go, i.e. stay on for a period, go off for a period, and then come back on. This will correspond to the CB guy pushing the mike button on his transceiver, on and off. There *may* or *may not* be horizontal black bars (one or two or three) across the screen *with* the herringbone beat. The horizontal black bars may also come and go, they are a product of the CB transmitter's *modulation*, and if they are there they should vary at an "audio rate" as the guy 10-4's and so on.

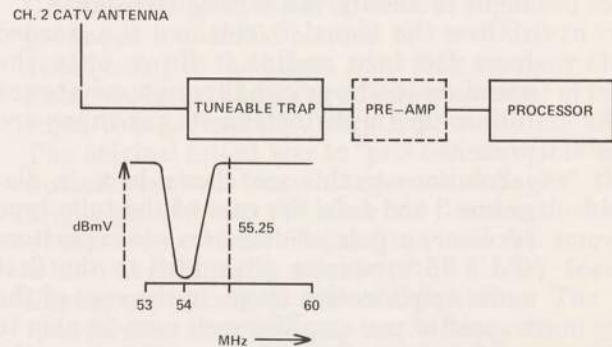

DIAGRAM 7

The second harmonic region falls squarely into the *lower* sideband portion of channel 2 (typically from 53.93 MHz to 54.51 MHz, see CATJ tear out reference card adjacent to page 9 in *May 1976 CATJ*). This is a frequency region where you could stick in a tuneable trap (Blonder tongue MWT-2/ etc.) tuned to that frequency region, and *probably* not degrade the channel 2 video information very much if the tuneable trap was stuck right on the money. This would help solve a headend problem.

The channel 5 affected region for *normal* Class D CB is 80.895 MHz through 81.765 MHz (channel 5 audio is 81.750 MHz). This is far enough up (i.e. high enough up) in the video carrier region where it will usually not produce a distinct herringbone pattern unless the third harmonic is very strong

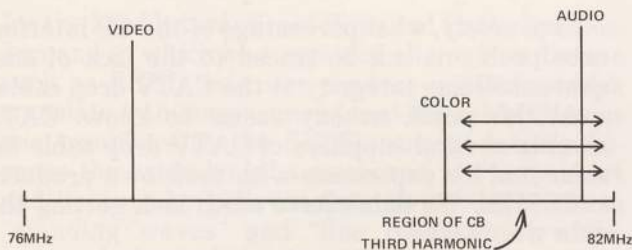

DIAGRAM 8

(i.e. almost in the dB for dB equivalent range of the TV signal itself). Carriers falling high within the TV carrier passband do much *less* damage than carriers falling low in the passband down near the video carrier frequency itself. It takes much *less* non-desired carrier near the video carrier frequency to produce a herringbone than it does at the high end near the color or audio carriers.

However, if it falls near the audio carrier frequency you may get AM detection of the AM signal in the receiver. A potent *CB channel 20-23* third harmonic that falls around or very close to the channel 5 audio carrier can *swamp* the audio AGC in a processor. The picture may look just fine (i.e. no beat) and the cable audio may not repeat the CB AM audio (remember TV audio is FM) if the conditions are just right. But the strong AM carrier falling inside or around the channel 5 audio carrier region will swamp (overload) the audio AGC in the processor, and "fool it" into believing that it is a strong TV carrier audio signal. This causes the processor aural AGC to swing into a

low gain range, which means the audio from the TV signal drops out (AGC shuts down audio gain range). So on the system you have "popping" channel 5 audio, the audio signal is there one minute and quiet or gone the next. It *almost* sounds like an "intermittent" in the processor audio AGC, with the coming and going of the channel 5 audio. *It is not.*

When you suspect you have CB TVI at any point in the system it is almost essential that you have a tuneable receiver to cover the CB ranges. A CB transceiver might be adequate (you can check for some clown that comes on and goes off at the same time your TVI comes and goes, *and thereby pin down the likely culprit*). But if the cause of your problem is one of those "elite sidewinder" guys who operates *above* 27 MHz (or below 27 MHz; they seem to have no allegiance to which side they work on) to correlate *their* on and off transmissions with your own on and off TVI, you will need a general coverage shortwave receiver that tunes beyond (i.e. below *and* above) the 27 MHz 23 channels allocated to Class D. It should be noted that *when* the sidewinder characters are *above* the 27 MHz Class D channels, they can easily be operating in a frequency range where their second harmonic falls *directly* into the channel 2 visual region (i.e. *not* slightly *below* as is the case with the normal 23 channels), and they will also then fall into the lower sideband video portion of *channel 6*, not channel 5. So just because you have channel 6 TVI problems don't write off "CB" as the cause. It may well be one of the "sidewinders" operating on his self-assigned channel well *above* 27 MHz CB by perhaps a half MHz or more.

So what do you do about *this* type of problem?

There is almost nothing you can do at your receiving site (including the CATV drop) if the problem *really* is a second or third harmonic problem. If it is a second *only* problem, and it is really CB (i.e. one of the 23 assigned channels), a sharply tuned trap set down just *below* 55 MHz may solve your problem. Buy beyond that, you have got to confront the *cause* of the problem, *the CB person*.

First of all, there are transmitter filters. One of the commercial units available is shown here. One of these is the R.L. Drake Company (540 Richard Street, Miamisburg, Ohio 45342) model TV-3300-LP. This unit installs in the CB transceiver transmission line and is for all practical purposes opaque to the 27 MHz signal, but has 80 dB of attenuation *above* 41 MHz. It will handle 1,000 watts of RF power (that should handle *most* of the high power CB'ers, if that is not enough for your guy, he can install the filter *between* one of his transmitter *low* [RF] level stages and his amplifier that follows). Another unit, the R.L. Drake TV-1000-LP starts rolling off the filter section at 30 MHz (also 1 kW power handling capability at 27 MHz), while a third is the R.L. Drake TV-42-LP which has a 43.2 MHz cut off (i.e. attenuates everything above that point) rated at 100 watts RF power.

Then one of the CATV companies we are all familiar with, VITEK Electronics, Inc. (200 Wood



"10-4 OLD BUDDY"...

- 1) ALL CHANNELS EQUALLY AFFECTED ?
- 1A) CHECK FOR AUDIO RECTIFICATION



" IN THE NEWS TODAY..."

- 1) ALL CHANNELS AFFECTED ?
- 1A) INSTALL HIGH PASS FILTER AT RECEIVER
- 2) CHANNEL 2 ONLY ?
- 2A) INSTALL LOW PASS FILTER AT CB TRANSMITTER

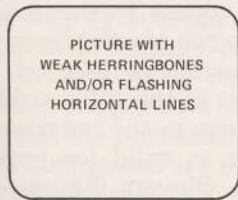

"10-4 OLD BUDDY"...

- 1) CHANNEL 5 ONLY ?
- 1A) INSTALL LOW PASS FILTER AT CB TRANSMITTER
- 2) ALL CHANNELS WEAKLY OR THE SAME ?
- 2A) INSTALL HIGH PASS FILTER ON RECEIVER



DRAKE LOW PASS FILTER

Avenue, Middlesex, N.J. 08846) has recently completed design of a clever piece of coaxial cable not unlike their CATV pay-cable-channel filters. This one is a 52 ohm section of line with UHF type connectors on both ends. It inserts into the line at the CB transceiver and attenuates the channel 2 and 5 harmonics by more than 40 dB. The unit functions much like the Vitek drop-cable-look-alike series of pay-cable traps; there are 1/2 wavelength trap sections concealed under the outer vinyl jacket and they trap the harmonic energy to ground so it cannot get into the CB antenna.

All of this presumes that the majority (or the devastating portion) of the second and third harmonic stuff is getting into the airwaves via the CB'ers antenna array. Recall if you will that in some tests conducted by CATJ and others it appears that *some* of the energy, especially that causing problems for the immediate city-town neighbors of the CB'er, may well be getting into the airwaves via the chassis-radiating on the CB transceiver, or via the power line wiring at the CB'ers home.

Frankly, a great deal more data is needed to pinpoint the real cause of this type of problem, and to ascertain the percentage of the problems which are traceable to this source. In that regard, there is the ongoing program which the FCC's FOB is now conducting, and there are independent tests including the CATA/CATJ contribution to the PURAC effort. The EIA people are also in the act, and there is a tug-of-war going on between the *EIA CB transceiver members* and the *EIA television receiver members*. One side wants -80 dB attenuation of any second and third harmonic energy at the CB transceiver (this means at the antenna terminals *and* at the chassis *and* backwards into the AC power line) while the opposite side, the CB manufacturers, want to settle for something closer to -60 dB. For now the FCC is sitting this one out, awaiting recommendations from both EIA groups and the results of their own PURAC program and their FOB tests. The CB manufacturers want lower numbers (i.e. -60 dB) for the same reasons that the receiver manufacturers want higher numbers. Whoever loses this one is going to have to spend more money (but probably not much) for their own products.

The Drop Cable

What about our drop cable? When is there enough shielding?

Conversely, what percentage of the CB interference problems can be traced to the lack of adequate shielding integrity at the CATV drop cable?

At this point, nobody seems to know. CATJ went to several suppliers of CATV drop cable for some real life experience with their own products at 27 MHz. We didn't have much luck getting the data we wanted.

BELDEN SEED PERFORMANCE CURVES DETAIL
SHIELD EFFECTIVENESS COMPARISONS

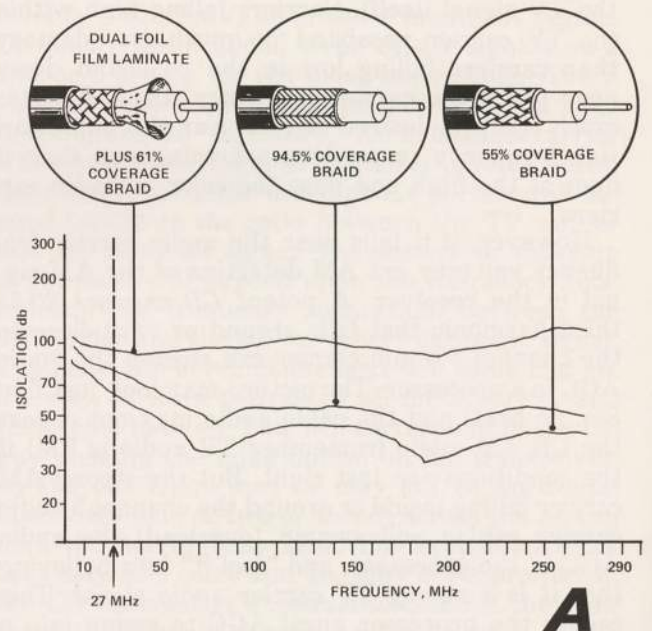

Logic tells you that the *better* the shield on the drop cable, the better the RF shielding. Fortunately for present users of drop cable, 40% shielding went away when quality drop cables began to be offered in the mid 1960's. Still, there is a lot of rotted (and rotten) braid drop cable still hanging out there in CATV land, and you may have a piece or two of it still up that is simply not supplying you with adequate drop shielding.

Chart number A here suggests that at 27 MHz the drop cable shielding integrity is largely a function of braid percentage and drop cable configuration. For example, this chart (supplied by Belden) suggests that a 55% coverage braid has around 57 dB of thru-attenuation. And the dual-foil film laminate *plus* 61% coverage braid is tops of these three with very close to 100 dB of thru attenuation. *But how much is enough?*

There is another more gnawing question. How do you measure such a thing? Some years ago Belden developed their "SEED" system. SEED stands for Shielding Effectiveness Evaluation Device, which is essentially a piece of machinery into which a selected length of cable is inserted, and with which the effectiveness of the cable's shielding is measured. Not everyone in the industry accepts the SEED technique as valid for real-life field situations. Kenneth A. Simons (Simons and Wydro Associates, Hilltown, Pa. 18927) is one of these. Simons prepared a paper entitled "Relating Transfer Impedance To Coaxial Cable Radiation"

for the 23rd International Wire and Cable Symposium and in which he suggested that a test fixture such as SEED *may not* produce numbers which translate into (long) runs of real-life cable. Simons has trouble with the SEED concept largely because the cable lengths measured are very short and because he believes they do not translate to "standing waves" and "line resonances" which occur when you hang up 100 or 200 feet of drop cable. The Simons paper illustrates and reports on an alternate technique for measuring cable shielding integrity. Simons hangs up a length of cable under test (typically 200 feet), terminates one end and connects the opposite end to a broadband display device such as a spectrum analyzer. Then Simons passes RF sources (such as a 27 MHz transmitter) along the suspended test cable for the full length of the cable, and measures and records the apparent ingress *into* the test cable as a function of the location of the test transmitter signal source antenna as it is walked or moved along the line. Using this technique, and repeating it at several different frequencies starting near 5 MHz and moving up to say 300 MHz. Simons claims one finds a wide range of not always related "holes" and "gaps" in the suspended test cable's shielding integrity.

At least one manufacturer of CATV cable has picked up on the Simons approach, using a test system and some equipment (call it a jig) which Simons constructed for such testing. That supplier who will go unnamed for the moment, found "no noticeable trends" for the cable suspended.

One fellow *who is willing to be quoted* at this point is Paul Miller of Belden. Defending his SEED machine, Miller notes "SEED was developed primarily as a standard of reference. The cable industry was going around quoting all sorts of apples and bananas numbers and it turned out we were all conducting the tests in a different manner. With SEED as a standard test system, we *may not* have the true real life numbers as Simons suggests, but at least when manufacturer 'A' puts a 2 meter length of cable into a SEED machine and runs number tests, he is conducting his tests in the same manner as manufacturer 'B' who puts his 2 meter length of cable in his SEED machine."

CATJ will publish extracts from the Simons paper in a subsequent issue along with some more data currently being prepared by the CATJ Lab and by some of the nation's cable suppliers.

Belden's Miller also has some candid comments on what *he* has observed when he has been called in to help system operators correct what appears to be cable leakage problems (leakage or egress and inward bound leakage or ingress have the same heritage, both are interchangeable for test and real life purposes). "The manner in which the cable connectors are installed is, I believe, the primary problem CATV people have with creating an ingress situation. We have found that when a CATV technician or installer cuts a piece of foil shield cable, that if he is not careful how he puts on

the connector, he can lose as much as 30 dB shielding isolation right there. Any foil shield cable simply must have the connector put on so that the foil is not slid back with the F fitting. If the foil passes backwards, that is, it is pushed back by the mandrel of the fitting, there is bound to be trouble. The mandrel may start under the foil at the beginning, but then it catches or is pushed crooked so that it catches the foil and the foil then slides back with it. This causes a gap in the foil overlap, and the shielding integrity is shot right there."

This observation of actual CATV field practices has led to the development of *bonded* foil shielding, which makes it *almost* impossible to push back the foil. Miller says that most systems are now utilizing the foil plus 67% braid shield drop cable configuration, and "if this is installed properly, any locally high level ambient signal is going to have a difficult time getting into the drop line."

But, as Miller points out, the installer is typically the least trained person in the company and low man on the totem pole. "I estimate that perhaps as many as 50% of the fittings are incorrectly installed; people have got to recognize that if a fitting is put on poorly, the shielding of the drop line can be severely affected. It does us no good to manufacture a high shielding drop cable if the fittings are put on by people who have the potential to destroy that shielding by 30 dB or more."

Where does that leave the harmonic problem? Pardon the pun . . . but still up in the air. As long as the CB'ers insist on *taking out* their TVI filters, *boosting* their power, and generally futzing around with their transceivers, as long as the CB manufacturers are hung up on how to best establish standards for chassis and power line radiation of both the fundamental frequency and harmonic frequency signals, the monkey remains on the CATV system's back. We may not like it . . . and we may have to take drastic action in some cases to solve the problem, but it appears that as long as the problem is here, and the FCC is unable or unwilling to step in and solve it, *we are stuck with it.*

It won't go away unless we help it go away. This may mean that we have to spend some bucks correcting some problems which we should not be responsible for (i.e. providing some new drop cables where the CB'er insists on running a kilowatt). This may mean that we had better learn to live with the problem, and start solving it on our own rather than *waiting* for someone to come along and *solve it for us (it will be a long-long wait).*

Towards that end there may be an area where a local CATV system can get involved *with* the local CB'er group to work out a relationship which will control if not eliminate the problem in your town. Within the amateur radio domain there are something called "TVI Committees," FCC sanctioned groups of local amateurs and local television receiver sales and service people who work together as an ad hoc group to tackle one-by-one TVI complaints. Usually when a CB'er or ham causes television interference, the people who are getting the lethal dose of RF into their receivers and hearing



EXTERNAL CB TVI TRAP—A CB'er who knows he has television interference problems may be "tempted" to invest \$7.95 in a slick blister packed "TVI Filter" such as this unit.

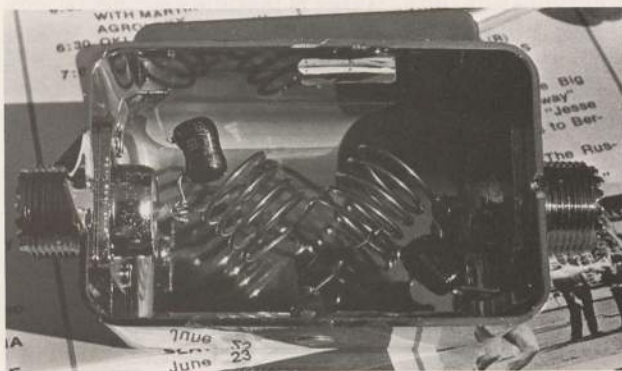

ANOTHER RIP-OFF?—Inside of the "TVI Filter" is the usual collection of coils and capacitors forming a low pass network. Energy "above 30 MHz" is supposed to be shunted to "ground" (inside of case of filter) where in the case of the filter is "reasonably RF tight," the energy dies for lack of a place to go (i.e. radiate to).

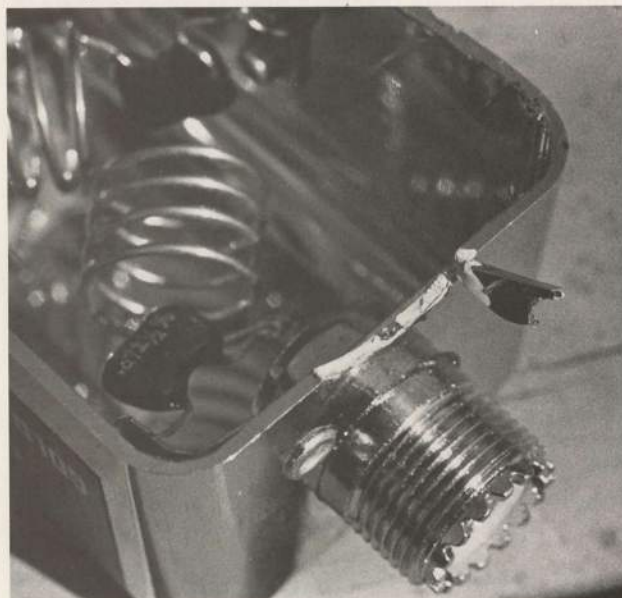

ALAS—The TVI Filter is housed in a plastic case (!) which although coated with what is generously called "conductive aluminum coating," probably has "near-zero" attenuation characteristics for 27 MHz energy. "This unit" had a "match" of 4 dB and isolation protection so low that it could not be measured accurately (i.e. the "case" was all but opaque to 27 MHz, 54 and 81 MHz signals).

aids are so mad at the local guy causing the problem that the two parties no longer speak together, although they may shout at each other quite a bit. The TVI Committee approach creates a body of people who are not directly involved in the squab-

ble to attempt to determine exactly *what* is causing the problem, and to then recommend to the parties what steps should be taken to correct the problem. If the transmitter operator is at fault he is usually grateful that somebody *other than* the FCC has helped him pinpoint the problem, and he is willing (usually) to solve the problem. He is willing, as we said, usually simply because the local TVI committee, made up of people who are capable of determining the true cause of the problem, will promptly turn in a report to the local or regional FCC office after the matter is resolved or brought to a determinable head. And most transmitter operators (regardless of whether they are CB'ers, hams, or the local PD) want to hold on to their FCC licenses. One way to lose them is to not cooperate when they are proved to be the cause of TVI.

Now if the problem is the fault of the receiver owner, the TVI Committee generally *carefully* explains how this can happen ("You mean my \$900.00 super whammy color receiver is at fault!!!") and then recommends that the set owner take a sheet of paper explaining the problem (left with the set owner) to *his* own serviceman so that the necessary filtering, high pass filter, by-pass capacitors (etc.) can be added to the receiver. The TVI Committee is *not* in the set fixing business itself, *and it never should be.*

So how does all of this relate to CATV operators? The TVI Committee approach is an established way of life for the amateur radio operators. But understandably, the amateur operators do not feel they should volunteer their time and efforts to solve problems for CB. So it remains for the CB'ers *themselves* to get "hep" to the TVI Committee approach.

This proposal, an outgrowth of the PURAC group that involves CATA/CATJ, is being presented to the CB users through one of their trade journals (*CB Magazine*, 531 North Ann Arbor, Oklahoma City, Ok. 73127) in the current (July) and August issues.

But *even with* their adoption of the TVI Committee approach, the CB'ers seldom have the skills and even less often have the necessary equipment or background to really relate to solving the problems. That is where CATV companies might lend a hand to get the CB TVI problem under control at least within their own communities. If you as a cable operator take the initiative with the CB club or group (or simply with an influential local CB user) *you can get a TVI Committee started in your own community.* To help out you should send a large self addressed envelope (9 x 12 inches in size) with \$1.00 in postage to the American Radio Relay League, 225 Main Street, Newington, Ct. 06111 requesting a *free* copy of the ARRL "Radio Frequency Interference Packet." This packet explains the legal problems and the do's and don'ts of getting a local TVI Committee going. It is the result of the amateur's twenty-five year experience with TVI, and while it will need *slight* modifications of format for the CB field, it provides an excellent starting ground.

KAY MODULAR CATV

test set

NEW TO THE MARKET

NEW 9021 RECEIVER/CHART RECORDER

Stores and prints complete frequency spectrum up to 400 MHz. Available with built-in timer (one quarter, one-half, one, and two hour intervals) for unattended CATV measurements. This portable unit provides easy to read response and facilitates 24 hour unattended operation. It can be operated on self-contained battery, external source, or ac.



9040 Spectrum Analyzer

Features a 72 dB dynamic range, phase lock, 1 kHz resolution, input calibration and manual/automatic filter control.

Price— \$ 2390



9020 Summation Sweep Receiver

Features a 40 dB post amplifier, 41 dB attenuator, markers, detector, and tilt control. Also built-in +15 dBmV reference signal.

Price— \$ 890



9030 Cabi-zyer

Measures gain/loss and return loss of active and passive device. Includes attenuators, electronic switch, bridge, and detectors.

Price— \$ 695

Find out more about our complete line of test instruments



FREE!

By sending for our catalogs and additional technical information.

KAY ELEMETRICS CORP

1 MAPLE AVENUE, PINE BROOK, N.J. 07058

Name _____ Title _____

Address _____

City _____ State _____ Zip _____

JULY 1976

“Dependability makes the difference.”

Richard C. Schneider
V.P., Engineering
United Cable Television



Magnavox

CATV Systems And Equipment

The eleventh largest Multiple System Operator in the country, United Cable Television is in an excellent position to evaluate Magnavox CATV Systems.

The "Flagship system" of United is in Tulsa, Okla., where Magnavox equips essentially the complete plant—600 miles of a planned 1,200 mile system. This plant is dual-trunk, single feeder, with a return available on 150 miles. Private channel capability on the "B" cable includes the latest state-of-the-art data, security, and other communications handling.

Two other United systems utilize Magnavox equipment—New Britain, Conn. and Casper, Wyoming.

How does Magnavox stack up? Richard C. Schneider, Vice President—Engineering for United Cable Television, reports.

Schneider: "In these three plants we give our distribution equipment a thorough workout. We get pretty wide ambient temperature swings in all three cities. Casper, Wyoming is extremely cold in the winter. Tulsa gets a -30° to 100° F swing.

"New Britain, Connecticut also puts equipment through a thorough test. Our dependability with Magnavox has been very good with all these systems.

"I've also been looking at Magnavox's new Micro-line equipment as a cost saving approach in more temperate climate areas. We plan to test this type of installation further in the future.

"We saw a real forward step in the business at Magnavox, when a leader in drop line devices went into mainstations to become a full-line supplier. I understand that before a lot of people realized it, there were some 8,000 Magnavox mainstations on line!

"Magnavox pioneered with hybrid IC's, compon-

ents heat-sinked directly to housings, and complete modularity. Competitors are catching up—which confirms the soundness of Magnavox engineering. But Magnavox has more experience with these advanced techniques and components.

"Magnavox builds performance and competitive price into its equipment. And Magnavox has also engineered the dependability that makes a difference in the bottom line, month after month."

Large plant or small. Turnkey installation. System design and bill of materials. Rebuild. Magnavox dependability can make the difference for you. We'll prove it. Call us at our toll-free number...800-448-9121 (East of Mississippi) or 800-448-5171 (West). Or write...

Magnavox catv division

Manlius, N.Y. 13104

Please send information on:

- Turnkey plant distribution systems Dept. J
- System design—bill of material
- Magnavox MX-404 Amplifiers
- Magnavox Passive Devices
- Please have Sales Engineer call.

Name _____

Title _____

Company _____

Street _____

City _____ State _____ Zip _____

EQUIPMENT REVIEW

KAY'S P9040 ANALYZER

Another "Box"

Well, here we are at the usually friendly CATJ Lab looking at another piece of CATV test equipment; the *Kay Elemetrics Corporation* model P9040 spectrum analyzer. The spectrum analyzer has gone through a number of phases in CATV; there have been any number of attempts to market for CATV use analyzers which had various features which CATV system operators should like, should benefit by, and should find useful in everyday system operation. Unfortunately, until quite recently, the industry has by in large ignored the advantages of an analyzer; largely for economic reasons.

Two past CATJ features, dealing with analyzers, are worth mentioning at this time. Back in our July 1975 issue CATV engineer Jerry Laufer of Gill Cable Company (San Jose, California) described a "do-it-yourself" elementary type of analyzer, which anyone with a small bag of parts and a Jerrold RSC series of set-top converter could produce on his own, in his own shop. That Laufer article proved so intriguing to readers that at the forthcoming CCOS-76 meeting in August approximately 15 registrants will have the opportunity to sit down with engineer Laufer and construct, using parts kits and a circuit board prepared for the task, a complete working elementary analyzer. These analyzers will go home with the CCOS-registrants, and hopefully they will serve as "models" for others in New England, the Southeast, the Pacific Northwest (etc.) to follow and copy in building their own working elementary analyzers. The CCOS-76 spectrum analyzer course filled up to capaci-

ty (30 registrants with 15 of these constructors) within two weeks of the CCOS-76 announcement and more than 50 additional would-be builders had been turned away by the middle of June.

Then there was the June (1976) CATJ analyzer piece by Raleigh Stelle; a short-course lesson for would-be users of spectrum analyzers who would, we hoped, profit from a general discussion of what the analyzer is, how it functions and where it has advantages over virtually any other piece of test equipment available today.

The analyzer came into CATV in the late 60's, but was largely a laboratory curiosity until the FCC came along in March of 1972 and laid down a set of *FCC mandated* measurements which every system was expected to make in the course of "proofing" a CATV system. When it became apparent to the FCC, in 1974, that many of the tests were difficult to make *only* with a signal level meter, and a couple were down right impossible to make *without an analyzer*, and the industry as a body was resisting the tests, the FCC backed off on several tests (including those that required the analyzer). During the interim, however, or March of 1972 until late 1974 when the FCC backed off, a number of companies with analyzer production capabilities got into the CATV market with magic boxes that promised to read everything from cross-mod to the amount of corrosion on your F fitting 500 feet above ground at the antenna. Several of these magic boxes carried the spectrum analyzer nomenclature. The test equipment manufacturers, perhaps naively be-

lieving the FCC would enforce its test requirements (and therefore the requirement for an analyzer in "every" headend) were anxious to fill what they envisioned to be an "overwhelming demand" for spectrum or spectral displays. When the demand did *not* materialize, and the operators engaged in wholesale if not coordinated resistance to the FCC mandates, the test equipment manufacturers slowly withdrew their interest (if not their products) and their promotion for analyzer products.

Whereupon, as in the best of fairy tales, a strange thing happened; CATV people began to get interested in analyzers. *Absent* the FCC mandate that said "and you shall rush right out and purchase an analyzer," systems people discovered *on their own* the analyzer was a downright nifty piece of equipment for reasons largely related to better system pictures and more absolute kinds of measurements. In other words, when the FCC mandate went away, the analyzer began to catch on, all by itself, simply because it *did* have alot going for it.

It is the story of seat belts personified. *It is* a better mouse trap, and as long as there aren't any feds telling us we must use it, on our own, we are reacting to the advantages of the box. Seemingly, had the FCC approached the technical measurements differently back in 1972, the industry on its own free-market initiative might have responded more favorably, more quickly, to the analyzer offering.

So here we are in 1976, riding the crest of a nationwide increase in analyzer interest, and by-Laufer or by-Texscan or by-Tektronix or by-Kay, if the feds will leave well enough alone, given a few more years, we predict more systems will have analyzers in use than will not.

The P9040

The Kay Elemetrics Corporation (Maple Avenue, Pine Brook, New Jersey 07058) is one of your quiet, not ostentatious

producers of quality test equipment. Their entry into the CATV business is neither sudden nor has it been with fanfare. Representatives of Kay have been attending regional and national CATV gatherings for several years, with their efficient-humming displays of analyzers, test sets, sweeps and a host of other basic, good operating, solid state 75 ohm test equipment. Their booths have never been large, and by-in-large their booths have never bustled with activity. We can't recall the last time a scantily clad girl tripped you and beat you to the floor in front of a Kay display booth. That simply is not Kay's style.

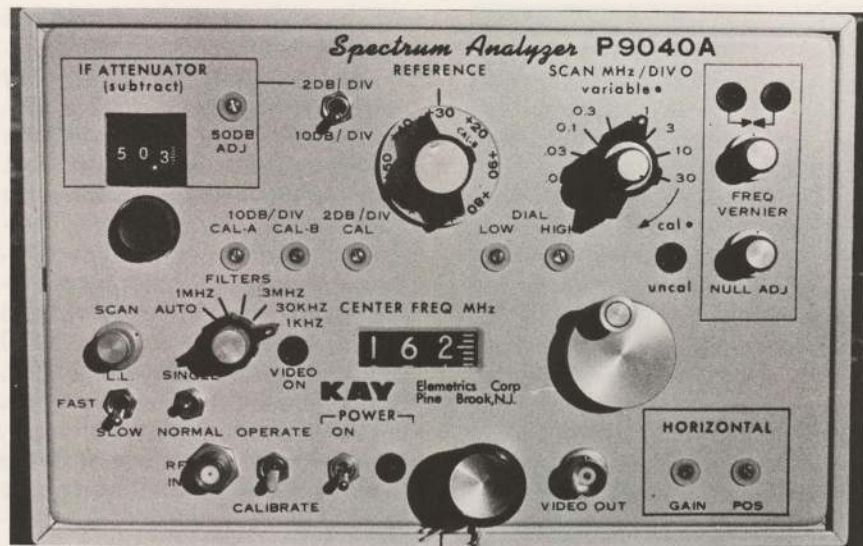

KAY ELEMETRICS P9040A—Analyzer is available as self contained unit, as plug-in for Tektronix (and other) series scopes, or as companion piece for external scope/display system.

Device—Kay P9040A Analyzer

Frequency Range—0.5 to 300 MHz

Dial Accuracy—+/- 1%

Frequency Scan—30 MHz/div to 0.01 MHz/div calibrated; 30 MHz/div to 0.003 MHz/div uncalibrated

Scan Rate—From 1 sec/div to line lock

Incidental FM—5 kHz p-p max unlocked to 0.1 kHz p-p locked

I.F. Filters—1 MHz, .3 MHz, .03 MHz and .001 MHz

Dynamic Range—62 dB minimum at 1 MHz b/w; 68 dB minimum at 30 kHz b/w; 72 dB minimum at 1 kHz b/w

Display Accuracy—+/- 0.2 dB maximum amplitude inaccuracy over full dynamic range

Amplitude Display—10 dB/div and 2 dB/div

System Flatness—+/- 1.0 dB over .5 to 300 MHz

Pricing—

P9040(A) Analyzer—\$2390.00

9014 power supply/main frame—\$195.00

9001AS Split Screen with storage display—\$1295.00

Manufacturer—

Kay Elemetrics Corporation

Maple Avenue

Pine Brook, N.J. 07058

(201/227-2000)

What is Kay's style is efficient, fairly priced test equipment that is probably in use in as many foreign countries and production centers in the United States as most other major suppliers of test equipment. Kay serves not only "our" relatively small 75 ohm market but a much larger 50 ohm market as well, and if careful study of used equipment price lists from those firms who profit from the sale of slightly used second-hand test equipment means anything, Kay's gear holds its value well,

and is in considerable demand by those people who know test equipment.

The P9040 analyzer is a basic 0.5 to 300 MHz machine, 75 ohms, with a host of up front controls which frankly "terrify" anyone who has never had his hands on an analyzer previously. The P9040 has apparently been designed by the same people who design Kay's highly professional line of production test equipment; people who while they know and understand well the requirements of the professional test equipment user, do not apparently identify with someone who has grown up using nothing more complicated than a frequency selective voltmeter (i.e. SLM/FSM). We mention this "up front" because it is our feeling, after making hard use of the P9040 in the CATJ Lab for nearly one month, that if there is any type of "problem" with the P9040, it is not with the analyzer itself; it is with the interpretation of the not-so-plain-English controls and manual-text into simple, everyday "This Is The Wonderful World Of CATV" slangese. Within its price range, we found by comparison and past experience that the P9040 offers the CATV user as good as or better-than performance unit for unit as any box on the market today. There are a couple of nice features which the P9040 has which make it stand out, within its

price range. But you might be several years finding them on your own if your one and only analyzer experience starts off with the P9040 in your shop.

In a nutshell, the box is a first class analyzer box with as many features as you will probably ever need. But unfortunately, the language on the front panel and the back up of the instruction manual simply fails to translate the features and versatility of the P9040 into first-timer instructions which the average guy is going to be able to follow.

So before you sit down with your friendly Kay sales engineer to play with the P9040 in your system, it is well for you to say to the man "Look, what I want is a plain English explanation of what this box does, how it can help me run a better system, and which control I turn where to get my measurements done quickly, accurately, and repeatedly."

The theory of operation of the P9040 is not dissimilar to other units on the market today. And because the June (1976) CATJ article by Raleigh Stelle covered basic design in some general terms, and the January 1975 CATJ (pages 41 to 50) covered it in some greater detail, we won't repeat that here. A block diagram of P9040 functions is presented here, largely to remind everyone that this analyzer, like all of the modern units, uses several separate conversion stages

to create first a high (UHF range) i.f., followed by several steps of downward conversion where selectivity is obtained for the often-most-important high resolution displays.

The P9040 analyzer is just that; a *basic* analyzer. It does *not* include (as *standard* equipment) a *display* system, and that is not such a bad idea when you stop to think about it. If your CATV shop has a *good* display scope, you can probably save quite a few bucks by having the *option* of purchasing a straight spectrum analyzer box (i.e. P9040) and then use your own *existing* oscilloscope for display. Whether or not your existing scope *will* handle the display function is something you of course need to check out with Kay simply because there are so many scope-feature-options and variables available these days that to properly describe all of

them would take more space than it is worth here.

Kay does not leave you *only* with this option; they offer several more. For example, the P9040 has been designed so that it very cleverly slides directly into the mainframe of a Tektronix 5100 series of oscilloscope. There is a small, not complicated, modification to be made of the Tektronix 5100 mainframe to accept the P9040, but that should not stop anyone. Thus you can have, optionally, the P9040 with an otherwise very useful general purpose high accuracy scope (the Tektronix scope 5100 series unit), and in this way you end up with *both* an analyzer *and* the Tektronix scope (with which ever Tektronix plug-ins you might wish for your own particular needs) for not much more money than a competitive analyzer (with built-in scope). That gives

you dual purpose for the test equipment package and should overcome many people's objections to having a display system associated *with* an analyzer, and therefore only useful *only* with the analyzer itself.

Then there is the P9040 plus storage scope and mainframe option. This is another clever approach where you end up with *two* displays on a *split* screen arrangement; one of the displays shows from memory a stored display while the other half of the display screen shows the real-time display. In this way you can store a "before" sweep, and then as you proceed to work on a piece of equipment have a constant on-screen reference to the way it was when you started. By photographing the display when you were finished, you would have a "before" and "after" display which would be very handy for technical per-

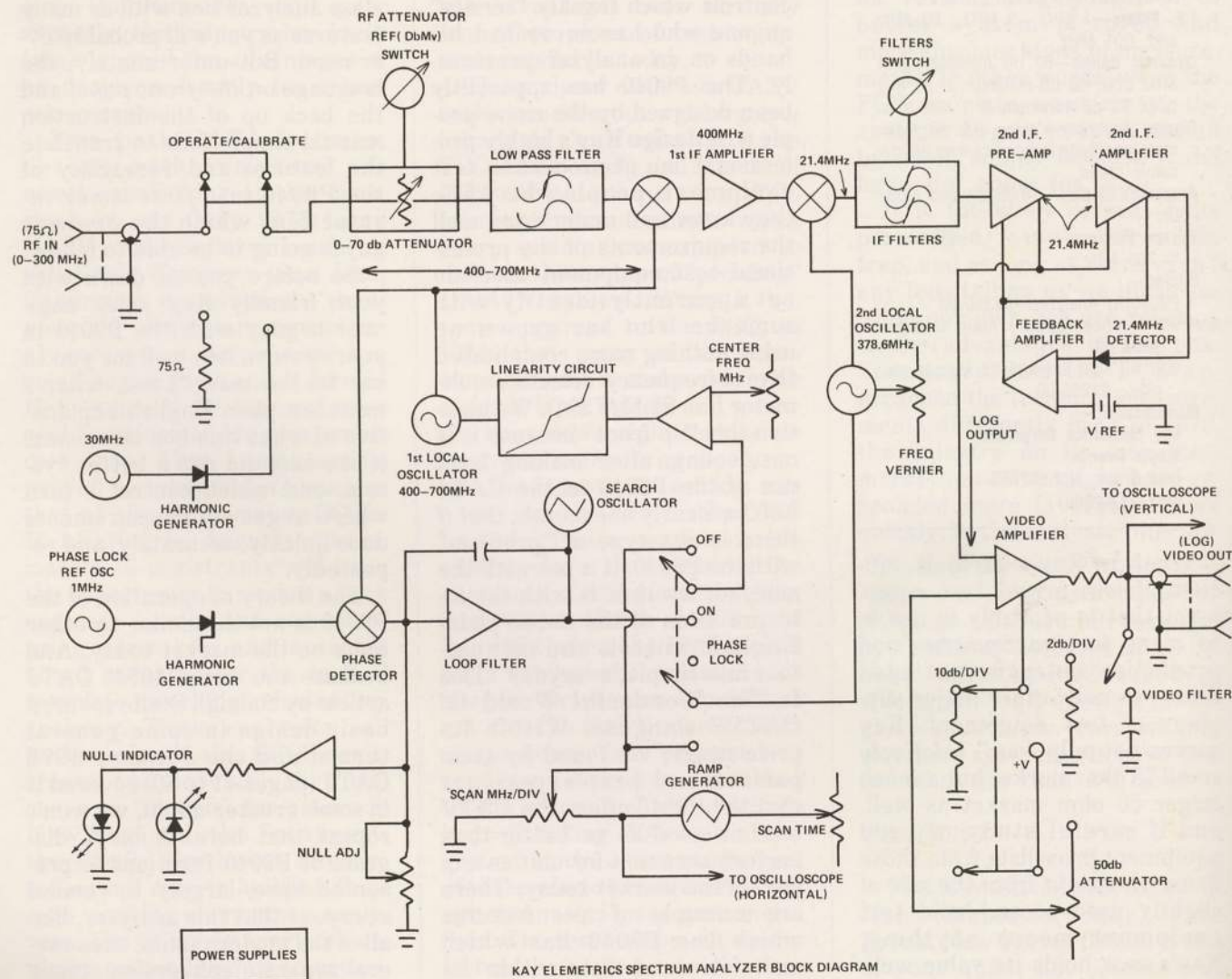

KAY ELEMETRICS SPECTRUM ANALYZER BLOCK DIAGRAM

formance records or FCC proof records.

The factory-provided *manual* for the P9040 package is at best "lacking." However, Kay does have an excellent manual prepared for them by Carmine D'Elia (former Chief Engineer for Warner Cable) which explains in adequate detail how the P9040 package is utilized (with other test equipment where and as required) to conduct *all* of the FCC technical tests (including cross mod and co-channel interference). The *basic* manual covers what the P9040 does, *but* it has been written with the *assumption* that the person operating the unit has a pretty extensive background in analyzer useage. On the other hand, the D'Elia "*Cable Television Performance and Maintenance Test Manual*" (available free of charge by merely writing Kay and asking for a copy) is about as extensive as any manual we have seen for test purposes. The manual is intended *primarily* to provide a working book for anyone conducting FCC tests, utilizing the Kay equipment package, but it will also provide others who wish to learn more about everyday applications of analyzers to CATV systems with a comprehensive study course.

Observations And Performance

Kay makes a big thing about calibration *and* accurate readings. There are a number of front panel controls for re-calibration of the unit under various conditions (i.e. calibration screws for adjusting the accuracy of the 50 dB i.f. attenuator, calibration screws for adjusting the accuracy of the 2 dB per vertical [screen] division and 10 dB per vertical [screen] division displays, calibration for making the "Center Freq [uency] MHz" tuning dial track with the window readout for center frequency, and so on). The *basic* manual (i.e. *not* the D'Elia CATV test book) does a good job of giving you 29 separate calibration steps to completely calibrate the unit. We seriously doubt you

would need to go through the *full* calibration procedure very often, but the fact that the controls are there *and* the instructions are there to do the job should give aid and comfort to anyone concerned about *really* accurate readings. Absolute accuracy, to ± 0.2 dB, is theoretically possible with the P9040 incidentally.

For very narrow scan widths (i.e. .03 and .01 megahertz per horizontal display screen division) the P9040 employs a "phase locking" circuit. This ensures that the carrier you finally end up centering on the display, or including in the display width of the screen, *stays put*. If you have ever gone looking for an intermittent case of co-channel, for example, that comes and goes as the tropospheric conditions come up and down, you can appreciate being able to set the analyzer on the *proper* spot, spreading the display out so you have a comfortable amount of display screen space between the desired carrier signal and a co-channel source signal (which you *can* find easily with the Kay by utilizing the *calibrated* parts-of-a-MHz per horizontal scale mark feature), and then sitting back and *waiting* for the co-channel source to pop up. In *some* analyzer situations it is necessary to sit and ride the display frequency tuning control to be sure you are *still* looking at the proper portion of the spectrum; but not so with the P9040, when the phase lock system is engaged. The phase lock system has a front panel LED display that flashes to tell you that you have the controls adjusted properly for locked-up-phase control of the signal.

Rather Than...

Rather than belabor the features of the P9040, we thought we would show you some of our "summer-trip-travel-slides" produced with the P9040 and a Tektronix 5100 series scope we happened to have in the Lab at the time (thinking back, we are sorry now that we did not ask to evaluate the P9040 *with* the 9001AS *split screen display*

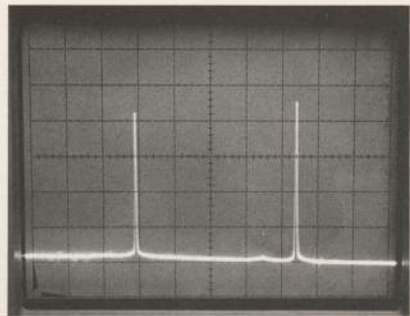

PHOTO ONE—Single channel off-air display (yes, aural carrier is stronger than visual carrier); i.f. at 30 kHz bandwidth.

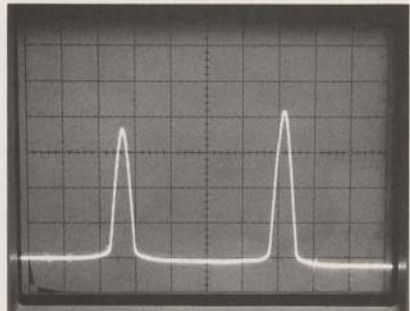

PHOTO TWO—Same channel 13 but now i.f. filter at 300 kHz bandwidth.

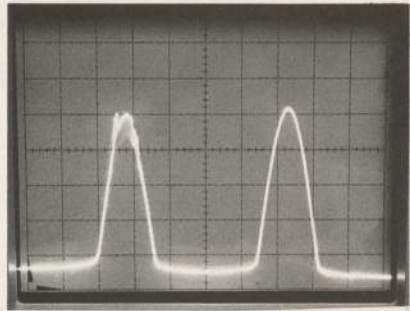

PHOTO THREE—Same channel 13; i.f. filter bandwidth 1.0 MHz.

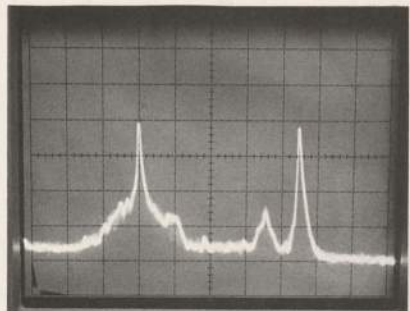

PHOTO FOUR—And now the vertical scale is switched to 10 dB per division and 30 kHz i.f. bandwidth. The difference between photos one and four? In "one" we are looking at the "tip-top" of the signal carriers while with photo "four" we have a "depth of field" allowing us to look down the side of the carrier clear to the bottom of the signal voltage and to the floor or base noise floor of the system (in "this case" approximately 36 dB signal to noise ratio at 10 dB per division).

storage scope, but perhaps another time!).

For openers, see photos one through four here. This is a sin-

gle channel display of an off-air channel 13 signal. The left hand carrier is the visual carrier and the right hand carrier is the aural carrier. Any comments?

Yes, the aural carrier is nearly 3 dB higher than the visual carrier. Something is amiss in the receiving antenna system we bet.

In photo 1 we have the analyzer adjusted for 1 MHz per horizontal division and the vertical scale is 2 dB per division. The i.f. filter is set for 30 kHz bandwidth. The i.f. filter bandwidth adjustment will change in the sequence here.

In photo 2 everything is the same *but* we now have i.f. bandwidth set at .3 MHz (300 kHz). In photo 3 we are looking at 1.0 MHz i.f. filter width and if you look carefully at the video carrier (on left) you can see the sync information crawling ("modulating") the *tip* of the carrier. All of these, again, are at 2 dB per division vertical scale.

Now in the fourth photo in this set we have switched from 2 dB per vertical division to the 10 dB per vertical division scale. Son of a gun, the signal has a color subcarrier present as well!

Now let's look at what happens when you zero in on one carrier and expand the horizontal display width. In this case our target is the same channel 13 visual carrier.

In photo 5 the horizontal display width is .3 MHz per division. In photo 6 we have expanded the display to .1 MHz per division (look closely at the top of the carrier, left hand side for sync tip). In photo seven the display is now .03 MHz per division (sync and some modulation in-

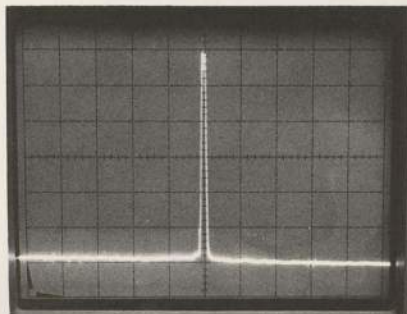

PHOTO FIVE—Channel 13 visual carrier only, in 2 dB per division scale, with 300 kHz per division display width.

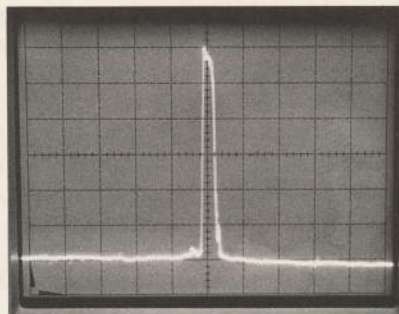

PHOTO SIX—Same parameters as five but 100 kHz per division width.

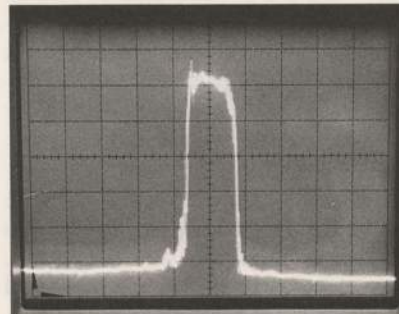

PHOTO SEVEN— Same parameters as five but 30 kHz per division width.

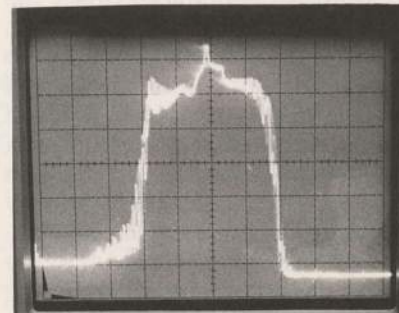

PHOTO EIGHT—Same parameters as five but 10 kHz per division width.

formation is plainly visible now at top of carrier) while the fourth photo in the set shows a horizontal display width of .01 MHz per division.

In our test system we had been experiencing some strange channel 6 problems for quite some time; problems which we suspected were being caused by *more than one* interfering carrier source. With the P9040 we went looking for the sources.

In photo 9 we see the channel 6 display, purposefully "off the top of the display screen" so as to allow us to look for some mighty weak beats and other problems we could see intermittently on the cable. In photo 10 we see one of these problems; a *set* of "carriers" just above the visual carrier frequency, *plus* a lone-wolf carrier stuck sort of midway between the color subcarrier and the aural carrier.

This problem turned out to be a local channel 5 modulator that was emitting "garbage" in channel 6 when the video source saw excessively strong yellow and

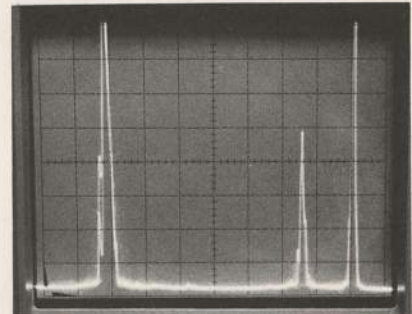

PHOTO NINE—Purposefully off-top-of display scale channel 6 showing three carriers that "should" be there.

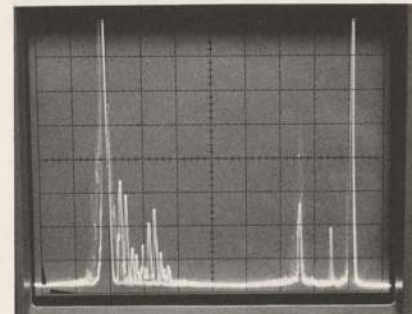

PHOTO TEN—Note interlopers just above visual carrier frequency and sandwiched in between color and aural carriers.

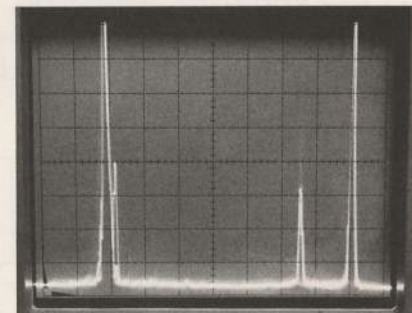

PHOTO ELEVEN—Note 84 MHz signal just a mark to right of left-hand (visual) carrier; third harmonic of local 28.0 MHz oscillator.

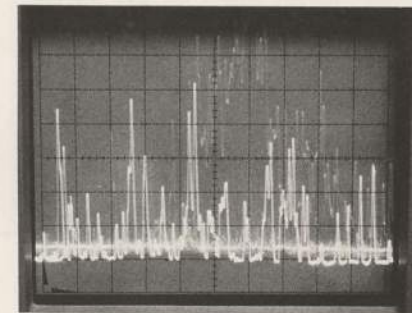

PHOTO TWELVE—The "signature" of lightning. Two separate "crashes" are displayed here (photo speed is 1/30th of second) with first display largely centered to right of center screen, fading out as photo was taken, but stronger than more widely disbursed-in-frequency second "crash". Frequency is channel 3 or 60-66 MHz. No TV carrier is visible in this mess.

orange backgrounds. A check of and realignment of the channel 5 video amplifier stages driving the channel 5 modulator cured that one.

In photo 11 we have our second channel 6 problem. Note that just above the visual carrier frequency there is a second carrier about .5 MHz up in frequency. This turned out to be a fundamental signal originating down on 28 (.00) MHz within an oscillator in the headend. The third harmonic (84 MHz) was potent enough to get into the channel 6 off-air receiving system. This was occurring intermittently, which made us sus-

pect an "outside" of the headend source. It turned out that we were wrong; the source was within the headend, and re-tightening the screws on the 28 MHz oscillator shielded enclosure cured that one. As to why it was intermittent... beats us!

Finally in photo 12 here we took the opportunity while a thunderstorm was passing 125 miles north of us to connect the analyzer to a search antenna and point into the storm. There was a mighty lightning crash which produced a display that was already fading from the CRT when we reacted with our usual split second reaction with the camera shutter (see *dimmer*

display concentrated to the right of the center line above the prominent display), followed by a second crash as we actually snapped the camera shutter. The second crash was (interestingly) more evenly spread in frequency (across whole 6 MHz display of channel 3) but not as potent (i.e. intense in dB's) as the first. There was no channel 3 TV signal evident in this mess and by calculating the pre-amp gain ahead of the P9040 we estimate the average lightning noise peaks in this display to be in the -20 dBmV range at the antenna output terminals. The display is 10 dB per division vertical scale.

THE WAY IT WAS IN CATV CATJ RE-LOOKS AT THE EARLY 60'S

The early CATV industry was largely unrecorded, the first national coverage of CATV began in January 1960 with the inauguration of a magazine called "DXing Horizons". DXH, as it was known for around 15 months, later became Television Horizons (TVH), and through the early years the editor and publisher was CATJ's present Editor-in-Chief Bob Cooper, Jr.

Browsing through the 1960-63 issues of these magazines is a study in the development

of an industry, from the days of five channel "fully loaded" systems to the then "modern" seven channel systems, and finally the 12 channel systems; the first introduction of solid state CATV line equipment, and the first inroads into "big cities" (Wilmington, N.C.).

Because there is so much to learn from our past, CATJ has selected various articles and short "news features" from past issues of DXH and TVH to help us all bridge the historical

changes which have shaped CATV into the industry which it is today. Material re-presented here is exactly as originally published, so if you have difficulty with the time-frame references, understand you are living in an era almost a generation ago!

In the inaugural issue of DXH, the following report appeared detailing an early CATV system's problems with "finding signal" in British Columbia.

Revelstoke, B.C.

Except in the very strongest of signal areas most operators of distribution and re-radiation devices will agree signal is where you find it. And in some locations finding that signal can be quite a problem! Take the headwater of the Columbia River Valley west of Revelstoke State Park in East Central British Columbia. The small town of Revelstoke, where until two years ago television was something they had "down south" (in Vancouver), but not one aluminum bird cage was to be found above the two story wood framehouses of this well to do mountain valley town. Revelstoke WAS isolated, quite effectively from television signals by both distance and the surrounding 9,000 foot mountain peaks.

WAS ISOLATED, until engineer C.E. Stephens read about KNIFE EDGE REFRACTION in Alaska, and began drawing lines on his topographical map. After several months of calculating and figuring, engineer Stephens decided that television reception was possible in Revelstoke, from the low power transmitter of CHBC-TV, Channel 2, 95 miles to the southwest in Kelowna. CHBC-TV runs but 3300 watts ERP, and to bring any usable signal over A FLAT LAND PATH of 95 miles would be quite a trick... but over a path which averages 4,500 feet ABOVE the receiving location would be a downright miracle. But Stephens didn't think so, and with a dipole cut for Channel 2 and a field strength meter

he began probing the area on the outskirts of Revelstoke for signs of signal. And he found it! Very spotty, in areas less than 100 feet square, and in low signal levels (10 uV or less). Re-calculating his figures and re-checking his map, he decided perhaps he had been looking in the wrong area, and began in another section... slightly further south. Here he discovered an area 200 feet long and 30 feet wide which boasted 20 uV of signal on the dipole—field strength meter combination. He was in business!

The secret of his reception? An 8,956 foot mountain. A mountain 15 miles SW of his receiving location, directly along the path between the transmitter and the receiver. The moun-

tain was actually amplifying the television signal! By a peculiar process discovered as recently as 1953, the mountain was providing a "knife edge" or "wedge" which as a prism diffracts light, was diffracting the VHF television signal. The principal is as old as light itself, but its application to VHF radio and TV signals was brand new. Actually, to provide maximum diffraction and the highest possible signal strength the mountain should be visible from both the receiving and transmitting sites, and it should be half way between the two. Moving the mountain closer to the receiver decreases the overall signal level, and makes the area in which the signal can be received much smaller. (Actually tending to focus the signal as a magnifying glass focuses light.) Stephens had used his topographical map to line up the mountains between the receiver and the transmitter, and using simple geometry he spotted where the signal should be, IN THE REVELSTOKE AREA. Then it was merely a matter of probing with a field strength meter until he found the signal in his previously plotted area.

As Stephens notes, one tremendous advantage to "knife edge or obstacle gain" reception is the almost complete lack of signal fading. Because it is line of sight from the transmitter to the "diffracting mountain" and line of sight from there to the receiving site, the normal fading characteristics to be found with fringe area reception (subject to the whims of weather fronts, etc.) is missing. In line of sight propagation there is little if any fading which can be traced to weather phenomenon. Therefore when his 20 uV of signal was amplified first by eight ten-element Channel 2 yagis (see photo one) to 75 uV, and then fed through an amplifier-AGC circuit Stephens had sufficient signal, with no fading, to distribute as "Central TV Systems Ltd." With a potential cable system of 500 subscribers, Stephens and his engineer George Henderson look forward to a

bright future with similar systems throughout the mountainous areas of British Columbia. Stephens already has plans to probe for signal from CHCT, only 185 miles to the east on Channel 2, but over the 11,000 foot Canadian Rockies.

Television is truly where you find it and perhaps the secret in finding it is to not to give up merely because the job looks impossible.

The April 1960 DXH contained a multi-faceted report on then-pending S.2653, a bill to create FCC authority for CATV regulation. The impact of the bill was considered, and various alternatives to FCC regulation were discussed.

Legislation Pending on Cabled TV Systems

As we write early in March the United States Senate is bitterly embroiled in a Civil Rights debate, the outcome of which will have no bearing on this topic, save the time it takes for the Senate to resolve that outcome. For in the Senate hopper, right behind the Civil Rights measure, is Senate Bill S.2653, designed to regulate and control community TV antenna systems in the USA. The bill, if passed with only minor amendments, would bring the operation of community cabled TV systems under the direct control of the Federal Communication Commission, and allow the FCC to enforce such points as follows, if they so chose:

- (1). *Require cabled systems to carry the programming of the local or semi-local stations, as well as that of the more distant "big city" outlets.*
- (2). *Place tighter control on the use of microwave relays for the purpose of carrying grade A television service to a distant town, for cable distribution.*
- (3). *Possibly outlaw cabled systems in areas where all three networks are available to viewers with off the air pickup (direct home reception).*

This last point is a mute one however, and considered to be possible only by the most radical opponents of Community Cabled TV (CATV).

There are an estimated 2.2

million homes in the USA that receive their television from cabled TV systems. Community TV antenna systems range from the smallest (serving a few dozen sets on a joint ownership basis) to the largest (some serving 10,000 plus receivers). Systems (nearly 700 large ones) provide service ranging from one snowy channel equal to fair fringe area reception, complete with good and bad nights, to systems distributing 7 channels, plus such "extra services" as 24 hour background music, and perhaps "local live television fare," on the cabled system, featuring local personalities, in news shows, etc. from a local studio.

PICK 'N CHOOSE

At the present time, with no authority regulating the operation of community television systems, system management is free to pick and choose the viewing fare it wishes to peddle to the local cable subscribers. In some cases this has involved a purposeful "non use" of the local television signal, which means *not carrying it* on the cabled system. This, "the local station" will tell you, is an unfair practice rendering them incapable of competing with the multiple station viewing fare available to cable subscribers. Isolated towns, such as Pocatello, Idaho, are normally served with only one station. Pocatello's only real market area is within the city itself, with only a pittance number of viewers scattered about the remaining countryside. But a cabled system, operated by Bannock TV, Incorporated, distributes Salt Lake City grade A signals (KUTV, KCPX, KSL) to the Pocatello subscribers.

CABLE SYSTEM MOUNTAIN TOP ARRAY

Bannock has their antennas (multi stacked yagis in a weatherproof building) on a 7,000 foot mountain, and their Salt Lake City signals are grade A all the way. No fading, snow, or interference. Had cable vision not found such good SLC signals close to town, they might have done what other systems have

done...install microwave relays from a point much nearer the transmitting station, bringing TV to the town to be served.

Such a microwave link is being installed across the mountainous regions between Seattle and Wenatchee, Washington. Wenatchee currently is fringe area viewing for Spokane stations on Channels 2, 4 and 6. But the *Consolidated Television Cable Corporation* of Wenatchee has dubbed a project to bring Seattle stations to the inland valley "big switch." According to *Consolidated Cable*, the new system will deliver Seattle stations to the valley area for cable distribution, at no appreciable loss, meaning receivers will mushroom (they hope). Of course the question asked by Spokane stations, "Why don't you distribute our signals to Wenatchee, we are a good deal closer" receives the stock cable company answers, "Seattle is the big city, with big city viewing fare...we have a product to sell...entertainment, so we have chosen the Seattle product because it offers more."

COMPLAINTS AND TROUBLE

Obviously such cable system policies, as found in Wenatchee, or Pocatello, are only two examples amongst the many, and such attitudes are bound to stir the wrath of *somebody-somewhere*. It has stirred the pot of TV broadcasters, most of whom insist they do not want their signals plucked from the ether and sold along the street by picture merchants. TV stations fighting CATV systems maintain that broadcasting is free, for the public. To this the CATV operators answer, "We agree, the service is free, and so are our programs, we are merely renting the viewer the use of our antenna to receive these *free broadcasts*." As well, CATV has invoked the wrath of western legislators who maintain that "even if CATV is legal, it should be controlled by the FCC," with regulations pointing towards fair and equal service for the local station in the town being served by the community

antenna group. At least one telecaster (KSPR, Channel 6, Casper, Wyoming) has left the air because of alleged CATV competition. KSPR left the air in the late summer of 1959, after stating they could not compete with the microwave system bringing Denver signals to Casper, nor with the fact that Casper's second TV station (KTWO, 2) was being carried on the cable, and they (KSPR), were not. KSPR claimed inability to compete with the economics of the situation, and threw in the sponge.

SOME STATIONS LIKE CATV

On the opposite side of the fence, at least one commercial TV station (WDAU-TV, Channel 22, Scranton, Pa.) has given the CATV service a pat on the back, commending it for greatly increasing the WDAU coverage area. WDAU claims it reaches an additional 90,000 TV homes through the efforts of area CATV systems.

NOT AN EASY QUESTION TO DECIDE

The FCC fully recognizes the CATV problem, like the VHF

More dBs per dollar with Starline 20/300A



Typical Performance:

System Miles: 200
System Bandwidth: 54-300 MHz
Channels: 35
Maximum Trunk Cascade: 25

The Total System Meets:

Carrier/Thermal Noise: 44 dB
Carrier/Synchronous Cross-Mod: 50 dB
Carrier/Composite Triple Beat: 53 dB
Carrier/Second-Order Beat: 63 dB

System Statistics:

Trunk amplifiers per system mile: 0.55; line extenders per system mile: 1.89; subscriber drops per system mile: 100.

This system uses a maximum of two line extenders in cascade.



JERROLD 
a GENERAL INSTRUMENT company

JERROLD ELECTRONICS / 200 Witmer Road / Horsham, Pa. 19044 / (215) 674-4800
The only total-systems CATV manufacturer.

booster-repeater problem, will not be an easy one to decide. CATV is too firmly embedded in the American countryside, with a history dating back more than a decade in the mountains of Pennsylvania, where it was born. It is not a broadcasting service, it is a reception service. Something the FCC has little power to control at the present time. The FCC is in a position to control the microwave licensing of CATV systems, where the more elaborate systems bring distant town signals to isolated towns, via single or multiple hop microwave, however.

PERHAPS THE ANSWER LIES TO THE NORTH

Once again Canada's Department of Transport (DOT) acting under the supervision of the Broadcast Board of Governors, has set a precedent by acting to control at least in part the activities of CATV systems in that country. And to date, the control system seems to be a fair and just solution, with no complaints heard from any quarter. Briefly, this is what the DOT has announced (in a September, 1959 release):

(1). *The licensee of a broadcasting receiving community antenna system is required to carry Canadian programs where the reception of such programs is technically possible.*

(2). *Where the area involved is not served directly by an existing Canadian television station, and where the area involved (that area to be served by the proposed CATV system) is in all likelihood too small to support a television station, and is not likely to assume such proportions within the foreseeable future as to be capable of supporting a television station, the DOT may give consideration to the application for a system to be served by microwave relay from a distant station(s).*

(3). *The license authorizing the construction and use of a radio (microwave) relay would become null and void at such time a station is established for television broadcasting in the area served by the CATV system.*

(4). *The DOT does not intend to*

license CATV operations in towns where existing television service is available.

This is the meat of the Canadian regulations, which are simple, straight forward, and direct. Such action, if adopted by our congress, as "in part" incorporated in Senate bill S.2653, might mean drastic changes in the multi-million dollar CATV industry in this country. And quite possibly, greatly reduced viewing fare for a million plus viewers in the USA.

By the November 1960 issue of DXH, a special CATV section had been created for monthly reports on cable activities. Under the "Cable Drop" heading, this report continued until it grew into a separate publication called Television Horizons in the spring of 1961. The following material appeared in the November 1960 issue as an introduction to the CATV industry.

BASIC TECHNICAL CONCEPTS OF CATV SYSTEMS

An introduction to CABLE DROP

With this article *DXing Horizons* starts a new and important series of reports-in-depth on technical topics relating to the community antenna television industry.

It is important to note that this first report is introductory in scope and content. As a general review of the basic technical components common to CATV systems it differs from future reports that will examine specific problems in detail.

In fulfilling its introductory function, this report provides basic information that will permit all DXH readers, some of whom may not be familiar with CATV, to proceed apace in their examination of community antenna television (CATV). The primary function of "CABLE DROP" remains, however, as a medium of expression by and for CATV operators.

The technical assistance of the staff of Entron, Inc., Bladensburg, Maryland, was especially helpful in preparing this material. In particular, Heinz Blum, Director of Engineering; James Carter, Director of Publications and Irv Kuzminsky, Director of Research and Develop-

ment, are to be thanked. These gentlemen, with their extensive experience, helped sort through the mountain of material available to indicate the important principles.

CATV OBJECTIVE

The technical objective of a CATV system is to receive RF signals at the system's antenna and to transmit and distribute those signals via coaxial cable without noticeable deterioration in signal quality.

SIGNAL DETERIORATION FACTORS

Signal deterioration in a system is caused by, (1) electronic equipment, (2) passive equipment, and, (3) poor layout and installation techniques. From the beginning to the end of a system, the signal passes through many components. Just as with a weak link in a chain, the component with the poorest performance characteristics will determine overall system quality. The components of a system also have a cumulative, or additive, effect on signal degradation.

The electronic components of a system can cause signal degradation by:

(1) Adding random noise signals; a phenomenon particularly apparent at low signal levels;

(2) Combining signals of different frequencies, thereby creating new, undesirable signals (*known as intermodulation distortion*), noticeable as a windshield wiper effect on receiver screens and apparent when electronic equipment is not properly operated;

(3) Generating signals of higher frequencies (harmonic distortion); apparent when electronic equipment operates improperly over a frequency range exceeding one octave (i.e. 50 to 100 megs.—plus).

(4) Generation of standing waves by reflected signals, noticeable as "ghosts" on sets and caused by a mismatch between the system and the equipment input or output.

In addition to the disturbing factors of these electronic components, certain passive ele-

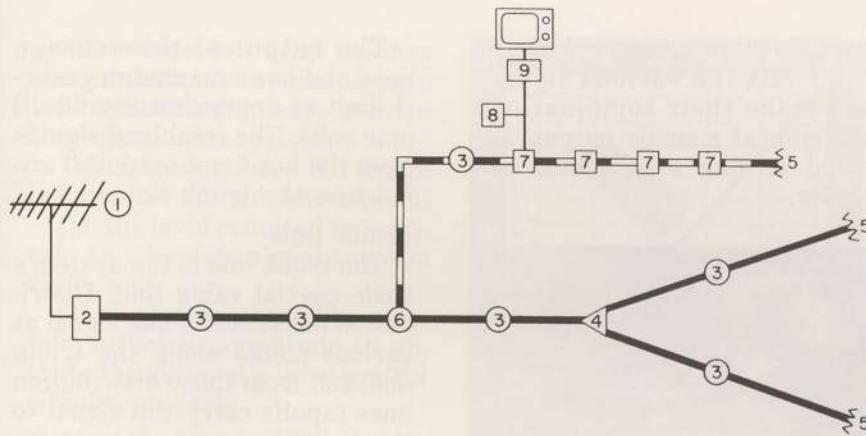

FIGURE 1

KEY:

- 1. ANTENNA
- 2. HEAD END EQUIPMENT
- 3. REPEATER AMPLIFIERS
- 4. LINE DIVIDERS OR SPLITTING TRANSFORMERS
- 5. LINE TERMINATORS
- 6. BRIDGING OR DISTRIBUTION AMPLIFIERS
- 7. TAP-OFF UNITS
- 8. GROUNDING BLOCK
- 9. TRANSFORMER

- TRUNK LINE
- DISTRIBUTION LINE
- FEEDER LINE

ments harbor a potential for signal deterioration by causing excessive loss or by reflecting signals.

Systems engineering and expert installation bear the burden of reducing the risks of abnormal signal deterioration.

FIVE ADJACENT CHANNELS OPERATING IN THE LOW BAND

The majority of community antenna systems carry the television signals on channels 2 through 6, in the frequency band from 54 mc. to 88 mc. Long experience with available equipment, layout and installation techniques proves that this frequency range lends itself best to systems. A basic system probably should operate within these frequencies and add other (high band) facilities as the state of the art permits and when necessary to accommodate growth requirement (i.e. additional channels).

Frequency Allocation

Standard television receivers are capable of receiving five adjacent VHF channels without any difficulty. The frequencies at which these five channels operate have to be located exactly as allocated by the FCC for channels 2 through 6. However, to assure trouble free adjacent channel cable system reception, equipment frequency drift must

be kept to a minimum; and the signal levels must be constant at all times.

Correct allocation and stability of frequencies is required to keep the carriers of adjacent channels sufficiently balanced to eliminate interference between video carriers.

A CATV system separately amplifies the audio and visual carrier for each television channel. Improperly adjusted the picture carrier of one channel might interfere with the sound carrier of the next lower channel. In turn, the sound carrier of one channel might interfere with the next higher channel picture carrier. Interference forms a buzzing noise in a lower channel sound signal or a distorted picture signal in the higher channel picture.

Signal Level

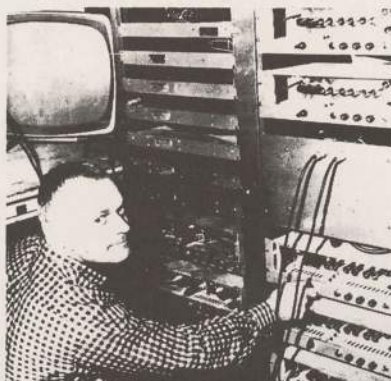

Making the many adjustments necessary at the "head end" of a multi-channel CATV installation.

To insure the best possible picture quality, correct signal levels and stability are required. If the levels are too low, television screens will display objectionable white spots, known as "snow" or "noise."

If a portion of the channels on the system are distributed at too low a level, the automatic level control for the trunk line repeater amplifiers (see figure one) will not perform properly. Through intermodulation, signals distributed at proper levels could be affected and distorted (windshield wiper affects).

Conversely, a signal level which is too high will also cause intermodulation distortion. Equipment specifications for input and output levels must be diligently followed to escape these problems.

Power Transfer and Matching

To offer the best power transfer between different parts of the system, and to avoid signal reflections, it is essential that the terminal impedance of all equipment in the system be equal. The equipment must be "matched." The CATV industry has standardized 75 ohms as the impedance value for system operation.

SYSTEM COMPONENTS

Five elements are usually involved in a community antenna television system: the antenna, antenna site, trunk line, distribution lines and feeder lines.

Antenna and Head End

Because CATV systems are generally located in areas where the strength of the signals received is low, the design, layout and installation of the antenna, antenna tower and associated components is considered critical.

Ideally, the received signals should have a minimum strength of 50 microvolts and should be free from noise and interference. The signals received are fed into amplification equipment located at the antenna site, known as the "head end." This head end equipment is specifically designed to:

(1) Reject undesired and interfering signals by means of narrow width or broadband rejection filters;

(2) Convert signals that are received at frequencies for which the system is not designed. UHF, high band VHF or baseband audio/video signals may be converted to low band VHF frequencies;

(3) Bring all signals to a level suitable for feeding into the system;

(4) Maintain all signals at proper levels, even when the input signal strength at the antenna site varies (*seasonal weather characteristics fre-*

quently cause great variations);

(5) Mix the various signals and make their combinations available at a single output terminal serving as a trunk line feeder.



The "ulcer department" of Ed Allen's Winona (Minn.) TV Cable Company, completely equipped with test gear.

The output of the average head end has a maximum general limit of approximately 60 dB (one volt). The combined signals from the head end output(s) are fed into the trunk line.

Trunk Line

The trunk line is the system's basic coaxial cable line. Distribution lines receive the signal at various points along the trunk line, and from these distribution lines tapoffs carry the signal to the individual sets.

The trunk line does not serve as a distribution line, and therefore, is never tapped to feed individual sets. In this manner the trunk line is kept free from disturbing influences and is able to deliver good quality signals over long distances.

The trunk line consists of a coaxial cable, repeater amplifiers, and supporting equipment. The coaxial cable carries the signals. The supporting equipment includes the poles, messenger wire, lashing wire and other hardware necessary to carry the coaxial cable.

Repeater Amplifiers

Repeater amplifiers are used at intervals along the trunk line to compensate for signal level loss caused by cable attenuation.

As mentioned earlier, electronic components can cause greater signal deterioration than so-called passive (or non-electric) components.

Nevertheless, the passive components used in a system should be of high quality to reduce the number needed. *In the case of trunk line, this means the cable should present the minimum amount of attenuation* (i.e. lowest loss per 100 feet of cable).

Low cable attenuation permits the system to operate with fewer repeater amplifiers. Thus proper selection of cable types plays an important role in the determination of trunk line attenuation, and system expenditures.

The signal strength loss caused by trunk line cable attenuation is offset by repeater amplifiers. These amplifiers are inserted in the trunk line at

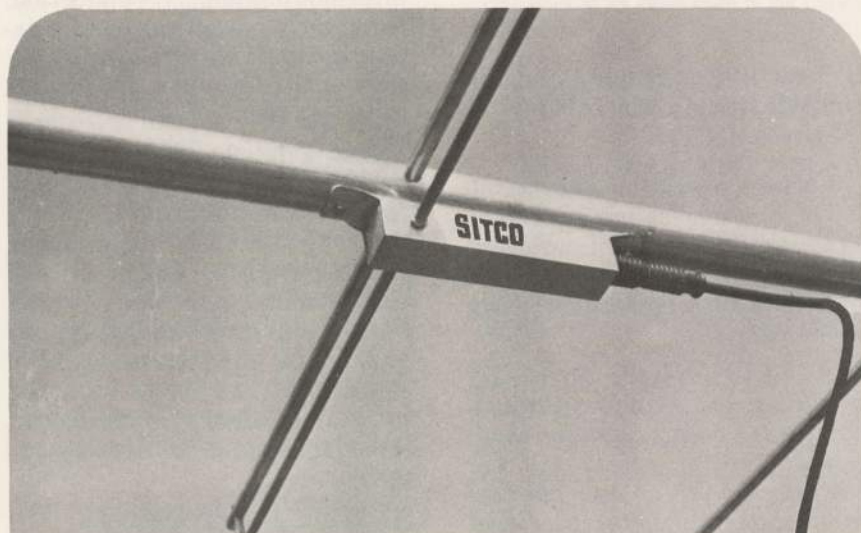

MAKE THE CHANGE

... from a barely acceptable signal to a good usable signal!

Install the new SITCO Model SBA-2 VHF Antenna Pre-amplifier. These pre-amps are exclusively and specifically designed as an accessory for the SITCO MA or CA single bay, single channel antennas.

The combination of the SBA-2 pre-amp, its companion PS-24 power supply and the MA or CA antennas will make an unbeatable low noise, high gain, clear signal installation.

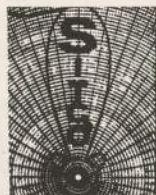

Write For Latest Literature
SITCO Antennas

10330 N. E. MARX ST. • P. O. BOX 20456
PORTLAND, OREGON 97220
Telephone 503-253-2000



points where the level reaches the minimum considered safe for maintaining quality service throughout the system.

Two factors govern the establishment of the minimum level:

(1) the level required to maintain an adequate signal to noise ratio, and,

(2) the level required to maintain sufficient amplitude to operate the automatic level control circuits properly.

Cable Attenuation vs Frequency

A complicating factor in the considerations of trunk line attenuation is the fact that cable attenuation over the VHF television frequency spectrum is not constant. Losses at higher frequencies are greater than those at lower frequencies.

This characteristic is known as the TILT of the response curve formed when cable attenuation is graphically charted. To compensate for the higher attenuation the higher frequency signals must be amplified more than those of a lower frequency. This process is known as "equalizing."

The (measured) signal strength over the entire frequency spectrum is constant at the INPUT to each repeater amplifier. At the OUTPUT of each repeater amplifier, the signals at higher frequencies are at higher signal levels than those of lower frequencies.

The distance between repeater amplifiers on a trunk line varies, therefore, the amount of equalization between amplifiers also varies. Each repeater amplifier must be individually adjusted to compensate for this TILT.

Splitting and Termination

Trunk lines can be divided by the use of passive line dividing or splitting transformers. These devices are properly matched to add the smallest possible disturbance to the trunk line signal.

The end, or ends, of the trunk line must be properly terminated in the characteristic impedance (75 ohms) of the system to reduce reflections and "ghosts."



99% of all LDS microwave systems now in use are Theta-Com AML.

Why be a guinea pig for test-lab gear?

Put your money and your signals where the best field experience is! Theta-Com AML is the standard of the industry. Now better than ever ■ Receiver sensitivity is doubled, with noise figure better by 3dB ■ Reduces size and cost of antennas for same performance ■ Improved propagation reliability and reduces signal-fade duration ■ Splits power into twice as many directions ■ Signal reaches more distant receiving points ■ And remember, AML is the only FCC approved LDS system. Call us toll-free at 800-528-6048. Today.

More than 100 AML systems delivered. Most in the world!

The All-American CATV Manufacturing Company

THETA-COM®

A subsidiary of HUGHES AIRCRAFT COMPANY / P.O. Box 9728 / Phoenix, Arizona 85068.
In Canada, AML equipment is distributed to the CATV industry by Welsh Communications Company.

Bank Financing Available

If you are seeking financing for construction, acquisition, extension or refinancing of a cable TV project, Sullivan State Bank in Sullivan, Indiana, may be able to assist you. The bank is also willing to participate with local financial institutions in loans with an SBA or FmHA guarantee in any locality.

The Sullivan State Bank has designated Communications Equity Associates as its agent to assist potential borrowers in preparing applications for cable TV financing. If you require financing, call Rick Michaels at CEA for details.

Communications Equity Associates

8200 Normandale Blvd., Suite 323
Minneapolis, Minnesota 55437
Tel: 612-831-4522

Distribution Lines

The distribution lines carry the signal from the trunk line to the customer connections. The signals are transferred from the trunk line to the distribution line through bridging or distribution amplifiers. These devices take a very small amount of power from the trunk line and insure that the trunk line signal quality is not deteriorated.

The distribution line cable, connected to the output of the bridging amplifiers, carries the signals to the customer "tapoff" units. Approximately 30 to 40 tapoff units are usually permitted in one distribution line cable.

Every tapoff unit adds a slight disturbance to the distribution line because of the tapoff unit's additional capacitance, resistance and inductance. These disturbing characteristics of the tapoff unit become particularly troublesome if the distribution line is long or if a great number of connections are attempted.

Distribution line *extender*

amplifiers are installed when the signal level on a distribution line cable decreases to a point where additional tapoffs would result in an inferior picture.

Feeder Lines and Tapoffs

A feeder line carries the signal from the distribution line to the customer's television set. The tapoff unit is the connection between the distribution line and the feeder line.

The tapoff units are attached to the distribution line cable and are selected to obtain the proper amount of signal power for a single set's operation.

A grounding block is installed where the feeder cable enters the customer's dwelling. This insures a good electrical connection between the outer braid shield of the feeder line cable and a reliable ground potential. Grounding thus protects the cable and the customer's property from static voltage build-up.

The final link between the system and the customer's television set is a transformer which

matches the 300 ohms input impedance of a television receiver with the 75 ohms impedance of the antenna system. This not only keeps the entire community antenna system matched but also results in a dividend, a two-to-one signal voltage boost.

So the signal arrives at the last and most important stop in its trip through the CATV system...the viewer's television receiver. In many respects, the viewer's set is the most important component of the entire CATV system. It is here that the system has both its beginning and ending.

The viewer's eager desire for adequate television in areas where this is difficult through other means establishes the basic need for a CATV system. In fulfilling these viewer interests, *the community antenna system becomes an extension of the set, permitting the viewer a broader television horizon than ever before.*

IDEAL FOR FSM CALIBRATION

EASIEST CALIBRATOR TO USE

Totally eliminates
cumbersome tuning required
by competitive calibrators

Sadelco, Inc. Sadelco, Inc. Sadelco, Inc.

Call / write for free color brochure

299 Park Ave., Weehawken, N.J. 07087
Tel. 201-866-0912

Available in Canada - **Comm-Plex Electronics Ltd.**
General representative for Europe:
CATEC AG, Luzern, Switzerland, Habsburgerstr. 22

1/4 dB ACCURACY 4.5-300 MHz



SPECTRUM CALIBRATOR MODEL 260-B

SPECIAL FEATURES:

- Extremely Flat White Noise generator
- 73.5 MHz CW Reference Generator
- Pulsed RF Reference Generator
- Precision Step Attenuator
- Ni-Cad Battery Powered
- Calibrate field strength meters
- Determine peak reading errors
- Measure gain, loss, and response
- An accurate standard signal source

Available at major CATV Distributors

While the late 40's and 50's are generally considered the "DXing period" for television expansion, the spirit lived well into the 60's as well. DXing is amateur radio talk for being "hooked" on infrequent long-distance reception. To get involved in the "hobby", a person needed a few bucks and a lot of spare time to gaze at the blank screen (which is what he saw most)...hoping against hope that a picture would materialize. Any picture, from anywhere. Second generation CATV pioneer Jamie Davidson of Batesville, Arkansas once observed "There is a little bit of DX'er in every CATV person". In the November 1960 issue of DXH, the following report appeared. Now here was a fellow with real stamina!

*Weak Signal Video
In Canada*

"STILL—the home of the true DXer"

Television in Canada did not get underway until September 6, 1952, when CBFT signed on with French-English programming in Montreal. Two days later CBLT took to the airwaves in Toronto (on channel 9), and video had finally arrived for an estimated 10,000 set owners in the Toronto area, who had been struggling with fringe area installations for nearly four years, watching snowy but acceptable

reception from WBEN-TV, channel 4 in Buffalo.

If one drove north from Toronto, in the summer of 1952, only months prior to the inception of local television in Canada, it would have been an education in DX reception. This writer did so, and many details of the trip are still vivid.

For some unexplained sociological reason, Canadians in general, and Ontario residents in particular, wanted video reception in the worst way. '52, you may recall, was the year of the commercial birth of the long yagi. Eight, ten and even twelve element models quickly replaced the time honored four and five element arrays across the U.S. Going north from Toronto, the single and stacked fives, cut to channel 4, evolved into single tens, and then as you approached Barrie on Route 11, double tens. North of Barrie, still on Route 11, and approaching Orilla, double tens had an addition...an antenna mounted pre-amplifier using the then

new cascode 6BQ7 tube. Approaching Huntsville and the 200 mile point from WBEN-TV, the antennas thinned out, in quantity, but the quality continued to improve. Now double sets of stacked tens (forty elements) were common, with open wire low loss line and pre-amplifiers at both the antenna and receiver. From Huntsville to North Bay, which nestles on the eastern shore of Lake Nipissing, there are few homes and even fewer television antennas. People in this area tell you of trouble with AM radio reception, and television, they explain, "is just for the city folks" in Toronto.

As early readers of DXing Horizons recall, television continued north to North Bay in those years...290 miles from WBEN-TV, North Bay resident Stan Hosken had television, *but it took a 276 element antenna to do the job!* (See DXH, February 1960, page 7.)

But the spirit of weak signal video reception, as evidenced by

STOP THEFT.

Our new Security Shield™ stops people from stealing your CATV equipment and service.

Just slip it on and thieves can't remove the converter or bypass Pay TV trap connections.

Stop the rip off that costs you thousands of dollars. With our 16¢ part. Write or call us today. (607) 739-3844.



LRC

ELECTRONICS, INC.

901 South Avenue, Horseheads, New York 14845



...and nothing but performance—no wasted space, no troublesome post in the middle of your cargo area

The first lift mounted far forward to give you the efficiency, the convenience of a one man aerial bucket lift on a van with no significant loss of capacity. 30' working height, plus all the features, all the stability, all the integrity you've come to expect from Durnell.

Call or write for an eye-opening demonstration.

DURNELL engineering, inc.

Phone 712/852-2611 • Broadway (Hwy. 4) South • Emmetsburg, Iowa 50536

the early viewers in Ontario, had its effects on the *Canadian Board of Broadcast Governors*. Pushed by the enthusiastic reception given WBen television by Toronto residents (all of whom were forced to pay exorbitant fees to import receivers from the U.S.), the BBG quickly OK'ed television for those areas already receiving American stations. It was a matter of pride, explained the BBG. Canadians should be watching Canadian Television.

**TO THE NORTH...
FAR NORTH!**

In 1954, the operator of the only radio and record shop in the Northwest Territory ordered a television receiver from Edmonton. The receiver, some yagi antennas, a booster and a few strands of wire were flown in, along with everything and everyone that came to Yellowknife. Harold Glick was his name, and in the next three years, he was to make weak signal television history. Glick had been following with interest articles in *Radio-Electronics* magazine, which detailed occasional DX reception. Assuming a "why

not attitude," he installed the receiver, stacked the yagis, and sat back to await results. He had read of E skip reception, and tropes. Calculating his nearest station to be CFRN-3, Edmonton, Alberta, 640 miles, he ruled out tropes. But skip, he and many others were surprised to find, *occurred on an average of eight nights per month...not just during the summer, but all year around!* And some of his best openings occurred in the spring and fall, when E skip activity over Southern Canada and the United States is practically nil.

Several patterns soon evolved with Glick DX activity. Located on the northern shore of the Great Slave Lake, he was as far due east of Fairbanks, Alaska, (1,000 miles) as he was north of Great Falls, Montana. He was less than 300 miles south of the Arctic Circle, and Aurora Borealis displays were frequent and widespread. He first suspected his semi-regular reception from such stations as KFAR-2, Fairbanks, Alaska, CBWT-4, Winnipeg, Manitoba, KXJB-4, Valley City, North Dakota and CKCK-2, Regina, Sask., was somehow associated with the aurora. He still believes so, although in the six years of experimentation Glick has learned not all auroral displays bring DX reception. However, in six years of working with DX reception, Glick has never seen more than the occasional burst before 1800 Mountain Standard Time, while DX often lasts until 0200 MST, when KFAR leaves the air for the night in Fairbanks. By southern standards, his station total is not impressive, nor are his distances. Glick's greatest distance has been WGR-2, in Buffalo, on several occasions, 2,000 miles. March and September are often the best DX months. May and June are usually the poorest.

Reception closely resembled E skip patterns in the states... strong video and audio, deep fading, occasional ghosting. It is not aurora, in the sense of the garbled video and audio...but most observers do believe it is a form of "cross aurora" skip, with



including **LOW PRICE!**

Jerrold's new ESSENTIAL FEATURES TAPS:
Economical and versatile—
for aerial or pedestal mounting.

A premium product . . . at a low price

Bandwidth

5-300 MHZ

Return Loss

20 dB input and output

Isolation

28 dB tap-to-tap

Current Capacity

Maximum 5 amperes,
continuous



Call or write our General Sales Manager for information about these new taps.

Name _____

Title _____

System _____

Address _____

Zip _____ Phone _____

JERROLD 
a GENERAL INSTRUMENT company

JERROLD ELECTRONICS / 200 Witmer Road / Horsham, Pa. 19044 / (215) 674-4800
The only total-systems CATV manufacturer

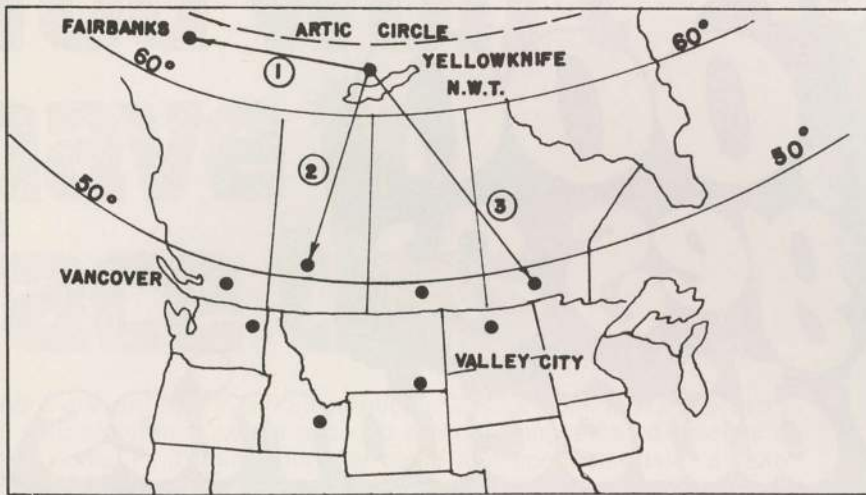

the signal riding with and through the aurora laden E layer in much the same way a surf board rides over and with a heavy wave.

**EXAMPLE... TYPICAL
SEPT., 1955**

(Excerpts from the log of Harold Glick, Yellowknife, N.W.T., Canada)

- Sept. 2 2100 MST—KFAR (Fairbanks)
- 3 2100-2340 MST—KFAR, KXJB (Valley City, N.D.), CBWT (Winnipeg)
- 5 2230-0100 (6th)—CHCT (Calgary, Alberta), CFRN (Edmonton, Alberta), KHQ-6 (Spokane), KOOK-2 (Billings), KFAR-2
- 9 2300-2330—KFAR, CBWT
- 11 2300-2400—KFAR
- 12 2100-2200—Channels 2-6 Active, KOOK, KHQ, KID-3 (Idaho Falls) identified.
- 17 2130-2330—CKCK, CFRN, CBWT
- 18-29 Only bursts.

For a two-year period, until near Arctic ice and winds beat it down, Glick experimented with a two bay rhombic array. His biggest complaint in six years of DXing? There are two: (1) "DX reception is so frequent up here that several dozen families have ordered TV receivers from Edmonton, and now I have to keep them going! We have a telephone network, and when DX appears, everyone is calling so they won't miss any reception.

(2) "Most reception occurs late at night... I lose sleep, and usually only catch the tail end of movies. I've seen station sign-offs a hundred times... but have never seen one sign-on!"

The December DXH reported on an event of considerable industry interest, the tenth anniversary of the pioneer Panther Valley Television Company. Bob Tarlton hardly looks a day older today!

Nationwide CATV Publicity

A WELL TIMED story in the nationwide circulation TV GUIDE magazine, during the week October 24 to 31 and the tenth anniversary of the Panther Valley Television Co. (Lansford, Pa.) was the cue for an interview over WDAU-TV (22—Scranton, Pa.), featuring Bob Tarlton (r.), President of Panther Valley Television Company. Shown here, Mr. Tarlton receives congratulations from Tom Jones (l.), liaison officer for CATV at WDAU. WDAU-TV represents what is undoubtedly the single largest feed station carried on CATV systems, and is currently used on 56 CATV systems throughout Northeastern and Central Pennsylvania, as well as eight southern New York State counties, total-



ing 92,000 CATV viewers.

The TV GUIDE story was widely exploited as an excellent public relations tool by CATV operators from Kennewick, Washington to Saranac Lake, New York. The National Community Television Association reports 19 TV stations cooperated with local CATV operators with air time interviews. Other CATV operators exploited the story with hundreds of thousands of article reprints circulated to TV viewers in their areas.

Continued pg. 44

Stop outages



Headend and distribution line outages cost you customer good will and they cost money. A CATV system with unreliable service will never reach its true potential saturation. Brown Electronics cures headend and distribution plant outages due to lightning and AC switching spikes with the full **Mini-Mizer** line-up of power protection systems. Full one-year guarantee, patented circuitry works for you twenty-four hours per day to prevent AC supplies and fuses from going on the fritz when lightning strikes or AC sources develop large transients. Models for every application, including 240 VAC primary and microwave sites.

BROWN ELECTRONICS
Artemus Road
Barbourville, Kentucky
40906
(606) 546-5231

Over 2,000 Pages & 110 directories

BIGGER & MORE COMPLETE THAN EVER...THE 1976

Television Factbook In 2 BIG Volumes

The **most complete** and most **easily used** reference work on electronic media and related fields in the industry—and the most **factual**—backed by solid professionals and **30 years of publishing experience**. ■ Since 1945, the **Television Factbook** has been the **authoritative source** for information on **all segments of the industry**. It is **used by**—and **for information on**:

• television stations, networks • TV and film production firms and programmers • advertising agencies • advertisers • manufacturers and distributors of broadcast, CATV and electronic equipment • station sales representatives • Community Antenna Systems • communication attorneys • consulting engineers • research, management and technical consulting services • brokerage and financing firms • the Congress and government agencies associated with broadcasting • educational institutions • libraries • publishers and associations. ■ **TV STATION COVERAGE MAPS** show Grade A & B contours. **At least one full page is given to each commercial television station** and includes such valuable data as: Percentage of coverage by counties—50% and over, 25-49% and 5-24%; total homes and TV Households, net weekly and average daily circulation—plus personnel, digest of rates, technical facilities, network affiliations, and sales representatives. ■ Educational, Canadian and International TV Stations have their own directories and are listed separately. ■ **NEARLY 500 PAGES** are devoted to **CATV SYSTEMS**. Systems are listed alphabetically by states and cities. Ownership, address, telephone, personnel, number of subscribers, pay-cable status, population, starting date, channel capacity, stations carried, equipment, miles of plant, homes in front of plant, subscriber fees, ownership, local originations, etc., are given for each listing. And in addition, all persons or companies which have an interest in two or more systems or franchises are listed in a separate directory. Canadian CATV Systems are also carried separately as well as broadcasters having CATV holdings. ■ **Also included** are: • complete tabulations of station and receiver growth since the start of TV • official FCC reports on financial performance of TV stations market-by-market, year-by-year • station-by-station tabulation of studio equipment (cameras, video recorders, etc.) • details on all TV station sales since 1949 • directory of CPs and pending applications • for each network • directories of executives, affiliates and affiliate board members • rates • TV channel allocations • translators—**and a myriad of other vital statistics.**

ORDER NOW!

With the 1976 Television Factbook at hand, you have immediate access to the most authoritative and comprehensive source of facts and figures on the entire universe of Television and CATV.

ONLY **\$74.50**

**\$67.00 FOR 5 OR MORE
FACTBOOKS ORDERED AT
SAME TIME.**

Send to: **Television Digest, Inc.**

1836 Jefferson Place, N.W. Washington, D. C. 20036

Please send _____ copies of 1976 Television Factbook.

Please bill me, including modest handling and shipping charge.

Please print

Name _____ Title _____

Company _____

Address _____

City _____ State _____ Zip _____

You won't have to face this

There are certain TV programs people in your community just don't want their children to see or hear. So Blonder-Tongue has developed a unique Home TV Terminal for pay cable that scrambles *both* picture and sound.

Other decoders on the market today, scramble *only* video. With audio in the clear, adult programming sound can come through loud and clear, even if the children can't see what's going on. This can cause problems. Further, non-subscribers can listen in and enjoy important sports events, even if they can't see them. It's also easier for subscribers to cheat when "video only" is scrambled.

And Blonder-Tongue assures complete parental control. A special key lock built-into the terminal provides, the parent with complete control over programming. When the parent leaves the house, he or she simply locks the set and there is no way for the babysitter or child to see or hear the pay-TV channel.

There's more to recommend this new decoder. A "barker" channel is available for operators who originate their own programming. On the other hand, the operator can use the "barker" channel for music.

The Blonder-Tongue Home TV Terminal. It's totally secure. It protects the family's privacy. For details write: Blonder-Tongue Laboratories, Inc., One Jake Brown Road, Old Bridge, N. J. 08857.

New Blonder-Tongue Total Security Pay Cable Terminal



BLONDER TONGUE



The February 1961 issue of DXH reported in broad over-view fashion on the manner in which television broadcasters were then cooperating with area CATV systems. With tongue in cheek, it would be so easy to bring this report up to date in 1976!

REPORT '61

Broadcaster Cooperation with Weak Signal Services

Certainly no 12 month period has ever held so much promise for the extension of television service into regions of the United States and Canada now without "a visual link to the world."

Taken collectively, *Master Antenna (Cable) Television*,

VHF Boosters and UHF Translators have extended television to an estimated six million Americans who would otherwise be without suitable television coverage. Viewed as a function of "set count," an estimated 1.8 million receivers perform solely due to the insight of a private businessman (*Master Antenna Cable TV*), or the determination of townspeople to bring television to their local area, where off the air direct reception is impossible (i.e. through *VHF Boosters, UHF Translators*).

But six million Americans is not an overly large number...

not to an advertising agency in New York, Chicago or Los Angeles, accustomed to thinking in terms of 40-60 million people. The total number of viewers interconnected to one or more of the three weak signal services assumes an important role only when you view it in perspective; *to the total number of sets, and viewers, in a given area.* As a matter of example, when you add 104,000 CATV sets to the coverage of WDAU, UHF channel 22 in Scranton, Pa., WDAU assumes a dominant role in the Scranton market area.

The Fall-Winter edition of *TV Factbook* will tell you the Scranton, Pa. and Wilkes Barre, Pa. combined "market" areas have a total count of 158,000 TV receivers. Adding 100,000 receivers to the WDAU coverage pattern (allowing for those set owners who "could get the signal off the air" if they were not on a Cable) is quite a shot in the arm for WDAU! In fact, talking trade talk in terms of market areas, WDAU, claiming 100,000 CATV sets, plus its off the air coverage of 158,000 plus receivers, can from a position representing the number 104 market in America move up *set count wise* to metropolitan Atlanta, Georgia (254,000)!

In the VHF Booster world the figures are not nearly so earth shaking, nor quite as reliable. But an example of "joint addition" can be found in Wyoming, where 15,000 receivers TOTAL coverage is considered substantial. KFBC-TV, Cheyenne, Wyoming is currently carried on seven CATV systems, located in Wyoming, Colorado and Nebraska. These seven *Master Antenna Systems* extend the KFBC signal to 13,500 receivers *which would otherwise be without its signal.* FCC figures indicate approximately 40 VHF Boosters also utilize the KFBC signal, adding an additional 5,200 receivers to the KFBC signal. All of these receivers... *the 13,500 on CATV, and the 5,200 via VHF Boosters* comprise "bonus coverage" which KFBC cannot for the most part reach directly. In affect, the bonus

**CALIBRATION IS IMPORTANT
don't buy 1/2 a meter calibrator**



The meter calibrator you buy will be used to check the errors in your field strength meters.

The most common errors are:

1. Absolute amplitude incorrect.
2. Attenuator inaccuracies.
3. Peak Detector problems.

Your calibrator must be able to:

1. Provide an absolute level.
2. Vary the output to check attenuators.
3. Modulate the output to simulate a TV carrier.

ONLY THE MC-50 DOES ALL THREE

What else do you do with it? The MC-50 is basically a signal generator with a frequency range from 4-300 MHz. It makes an excellent marker generator, emergency pilot carrier and general utility instrument.

MC-50 \$695.00

Delivery 2 weeks

MID STATE COMMUNICATIONS, INC.

59 N. SECOND AVE. BEECH GROVE, INDIANA 46107

coverage doubles the KFBC "off the air" coverage of 15,000 receivers by 18,700 more receivers. *Like adding another Cheyenne, Wyoming to the KFBC signal area!* It's no wonder then stations like KFBC and WDAU are unusually vocal in their support of the weak signal services!

And is it any wonder that progressive weak signal service operators are capitalizing on what was once thought to be, "by nature" an unfriendly relationship?

Nor is it so surprising to learn that a "score" of TV Broadcasters are planning VHF Booster outlets in surrounding centers of population, which today do not receiver good quality "off the air" reception?

As the facts will point out, most Broadcasters do want to cooperate with the weak signal services. But in many cases, where the non-progressive weak signal service operator is backward in HIS thinking about interservice cooperation, the broadcaster has no alternative but to attack the problem himself.

UHF TRANSLATOR COOPERATION

Undoubtedly the most publicized use of UHF Translators by a broadcast station licensee is in New England. Springfield Television Broadcasting Corporation (licensee of WWLP-22) has long been an advocate of "competitive television" based on use of the UHF spectrum by all TV Broadcasters. William Putman, President of the concern, is one of 12 men on the organization committee involved in the *High Power New York City UHF Test* detailed in the January *DXing Horizons*. WWLP is repeated through two UHF Translators located in Claremont and Lebanon, New Hampshire, both owned and maintained by the station. Springfield Television holds construction permits for two additional UHF Translators for Athol and Adams, Massachusetts.

In the "far west" Hawaii is another hot bed of Broadcaster owned Translators. Lihue, on

the island of Kauai, boasts three units operated by three Honolulu Broadcasters. Engineers familiar with the installations told *DXing Horizons* the UHF units operate from a bluff with an over water shot to Honolulu. Each Honolulu station (Kaiser owned KHVH-4, KONA-2 and KGMB-9) is responsible for maintaining its respective Translator, serving Lihue.

Henry J. Kaiser also operates a channel 76 Translator at Honohina which repeats Kaiser owned KMVI-12 in Wailuku.

Except for the Hawaiian examples, broadcaster owned UHF Translators are located where UHF Translators for the most part aren't normally found. This is true in New York state where WINR-40, Binghamton, New York operates a pair, in Hillcrest and Johnson City. This is also true of what is commonly thought to be flat land, Ohio, where the state's entire three UHF Translators are owned, and operates, by UHF broadcasters desirous of increasing their coverage. Zanesville station WHIZ-18 spotted UHF Translators in Cambridge and Coshoc-ton to give its signal a little better range. Marietta, Ohio is the new home of UHF Translator W70AD, operated by the Zanesville Publishing Company (Licensee of WTAP-15, Parkersburg, West Virginia).

In Pennsylvania, the competitive spirit seems to have carried from Lihue, Kauai, Hawaii to Clarks Summit-Waverly. High atop the summit, not far from the New York state line, WBRE-28 Wilkes Barre and WNEP-16 Scranton have spotted UHF units W79AC and W73AC respectively.

The future use of UHF Translator by Broadcasters is perhaps dependent upon the future of television itself. Readers will recall a "hypothetical FCC solution" to the allocations problem reported in the December *DXing Horizons*, which included as an integral part of the solution the use of UHF Translators licensed for *restricted local programming*. Certainly the UHF Translator has proved it can be

a useful aid to extending coverage, and a low cost method of filling in coverage nulls.

MASTER ANTENNA CABLE TV-BROADCASTER COOPERATION

The examples of inter-service cooperation in the CATV field are many. In instances where Broadcasters have established a policy of working with area CATV systems, the Broadcaster has been richly rewarded with many new sets added to his coverage area. The only station in the United States currently believed to have a full time "CATV Liason Officer" is WDAU in Scranton. Thomas J. Jones, in charge of CATV contacts for the station, tells *DXing Horizons* "The total number of extra viewership represented by CATV subscribers in our coverage area becomes larger each month. The recent additions of several new systems to WDAU-TV's radius umbrella brings out total CATV homes to 104,000.

This CATV coverage makes it possible for WDAU-TV to claim 1.5 million viewers in 20 Pennsylvania and 8 New York counties.

Coverage wise, "Ithaca, New York to our north (72 miles); east to Port Jervis, New York (62 miles); south to Lewistown (125 miles); and west to Lock Haven (100 miles) represents quite an enlargement of WDAU-TV's coverage" thanks to CATV systems.

So enthusiastic is WDAU-TV over its working relationship with the area CATV operators that the station habitually reserves a hospitality suite at the annual convention of the nation's Community Television System operators.

HOW DOES CATV HELP BROADCASTING BUSINESS?

It may be a matter for sorted wisecracks among station managers, but the hard fact is that on the one hand Broadcasters are delighted to add CATV coverage to their rate card material, while on the other hand, they would just as soon quietly "knock CATV viewers from the total set count" when film

sellers are in the office. CATV-station relationships have not yet matured to the stage where a CATV viewer is considered *just another viewer*; i.e. John Q. Public and his rabbit ears. Consequently, station time salesmen, not quite sure how to handle their CATV coverage, often reserve it as an "afterthought" to be used when a prospective client is on the border line of signing a contract for air time. Thrown in as "Oh yes, did you know we have 50,000 viewers on Cable TV systems" often does the trick as a surprise bonus to the prospective advertiser.

But on the other hand, the

same station may wish to deny it is used by a single CATV system, when a film salesman is in the office to peddle "Lassie." This is because films are charged to the station on a complicated formula based upon the number of receivers within the range of the station's signal. *According to theory, the more receivers, the higher the cost to the station.*

But despite these "yet to be ironed out problems" the simple fact is "anytime a television broadcast station is able to add a substantial number of viewers to its coverage without cost to the station, station management

is delighted." Any expressions the contrary are pure hypocrisy.

On the documented side, Broadcasters aware of the CATV potential, and anxious to work with area CATV operators, report they have established friendly working relations with CATV engineers and management personnel. The same stations report they can rely on CATV operators to verify certain facts about station coverage otherwise difficult to obtain. Armed with these facts (concerning not only set coverage, but also viewer habits, etc.) the station is often able to obtain a better standing in the eyes of advertising agency representatives, time buyers and other media personnel.

One station executive reports that when he visited a New York City Advertising agency, the agency personnel queried the station's reception in a certain city. The station operator was able to verify his station's standing in that city by telephoning the CATV system operator there, who in turn described the station's reception on his Cable System.

Many stations make it a point to visit all systems within their areas, whether the system is using the station's signal or not. The object of the visit is to explain to the system operator why the system's viewers would "prefer" their station to others available. Some of the sales points stressed by the station personnel include local weather reports, local spot news events, local sports, local commentaries and special feature programs concerned with local issues.

A few systems encourage system managers or engineers to phone the station collect when problems arise at the system because of *apparent transmitter difficulties*. Such events as sudden-unexpected co-channel interference, etc. may often be corrected or explained at the station, which may save the CATV system engineer for an arduous trip to his remote antenna site.

Reversing the process, many

LOW COST CUSTOMER ADDERS BY ELECTROLINE

ELECTROLINE solid-state CATV amplifiers have proven themselves in hundreds of CATV systems throughout North America in all types of weather and environments. If there is truly an "install and forget it" low-cost customer-adder amplifier line, any place in the world, ELECTROLINE is it! Available through three U.S. representatives and factory-direct in Canada.

ELE-126-412 (F) — a 50-300 MHz tilted response in-line amplifier cable powered by 18-30 VAC or 30-60 VAC. Output power blocked; current load 15 mA. 12 dB gain at 216-300 MHz, 7 dB gain at channel 2. Output capable +34 dBmV for -57 dB cross mod (12 channels). 10 dB noise figure, 15 dB match, and hum-mod down 60 dB. Just insert in the (line-powered) feeder line and it operates! Priced as low as \$13.00 for .412 (with connectors) and \$11.00 for "F".

ELE-115 — a 40-300 MHz apartment/house drop/multiple output situation amplifier powered by 117 VAC. 12 dB gain, 8 dB noise figure. Output capable +34 dBmV for -57 dB (12 channel) cross mod. Draws 1 watt of AC power! Priced as low as \$11.50.



IN CANADA — CALL COLLECT

ELECTROLINE (Television Equipment Company)

**8762-8th Avenue, St. Michel
Montreal, Quebec H1Z 2W4
(514/721-7162)**

Available in USA from: Jerry Conn & Associates (717/263-8258); B.E. Duval Co. (213/833-0951); D.B. CATV Suppliers, Inc. (516/822-6513)

stations call the CATV systems when trouble develops at the station transmitter. In other instances, when trouble develops at the transmitter (i.e. loss of sound) stations have been known to transmit special video slides directed at CATV viewers, advising that *the trouble is with the station, and NOT the CATV system*. One CATV operator reports this simple station courtesy often keeps his phone *on the hook*, when previously it would ring continually while the transmitter trouble continued.

Frequently CATV System operators receive visits from station personnel anxious to maintain Cable operator goodwill, and many stations continually feed copies of external written material going from the station, to area system operators.

It is not unusual for CATV people, meeting in a regional conflag, to be the guests of local TV stations for a guided tour of the "real head end equipment" feeding their system. Such a recent tour was arranged by Richard Dunning, station manager at KHQ in Spokane, when the *Pacific Northwest CATV Association* met there.

Other reports of cooperation between Broadcasters and system operators include:

"At least one station buys outdoor billboard space advertising programming in towns with a system receiving its signal."

"Some stations prepare special filmed on-the-spot or live programs saluting CATV communities."

"A number of stations use "stringers" (local in-town reporters to feed the station items of interest) from CATV covered towns."

"System managers work with TV Guide, or the area programming guide, to assure proper station listings for their area."

"System engineers frequently make signal strength measurements for Broadcasters, and on occasions have done so throughout long periods of time while the station was testing different antenna patterns."

All told, the CATV operator-

Broadcaster relationship is destined to improve even faster in the 60's, and especially in the year ahead. *A growing awareness of each end of the job being done by the counterpart is certainly a healthy sign for all concerned.*

VHF BOOSTERS- TRANSLATORS

Utilization of the coverage expressed by VHF Boosters fall into two distinct categories. *The present, and, the future.* In terms of the present, an estimated 1500 VHF repeater units (two thirds of these have registered with the FCC) serve 1.4 million Americans with their only viewing fare. VHF Boosters, serving areas which for the most part are too small and spread out for CATV systems, and too small population wise to afford the more expensive UHF Translator, serve a real need in the TV allocations picture. One very good example of cooperation afforded to Booster operators by a Broadcaster can be found in western Montana, within the coverage area of KMSO-13, Missoula. Don Hayes, National Sales Manager for KMSO told *DXing Horizons* "Our coverage area, though large, is confined within some pretty high mountains to the east and the west. We are extending our coverage into "valley communities" by means of the VHF Boosters. All 18 of the VHF Boosters now rebroadcasting KMSO-TV were set up in past years by citizen's groups who wanted our line up of NBC, CBS and ABC programs. Booster equipment salesmen and the citizen's groups worked together to complete installations and KMSO did not participate.

"...As it is important to KMSO-TV to gain additional TV viewers in order to compete for national spot and network advertising, we are taking steps to help Boosters put out as good a signal as possible within the one watt restriction (limit). As we have the most and best electronic test equipment available in the area, we are offering to let Booster Technicians bring

their equipment here for repair work.

"...The reason for KMSO-TV's move to set up our own servicing plan of assistance is because it was necessary in order to assure the viewers a good picture."

KMSO-TV did not actually participate in the establishing of any of the Booster units, but when they came, they did all they could to help out. Another approach to Boosters was taken by Chief Engineer J.H. Seide at station KNOP-TV in North Platte, Nebraska. Seide told *DXing Horizons* "We at KNOP-TV found we had holes in our coverage, due to the terrain or a noise factor at the receiving site. Lengthy studies told us that increasing our effective radiated power (now 26 KW visual) would only partially correct this lack of coverage, and would be very costly, at least \$150,000. We finally decided that six VHF (Boosters) Translators would fill in the major "coverage holes," where there was substantial population, and they would cost us, installed, around \$2,000 each.

"In the first six months of operation we had only one failure that just replacing a tube or tubes would not correct. The Translators are serviced every 50 to 60 days, and we found that with power line regulators, this is often enough."

"There are a total of 11 VHF units repeating our station (that we know about). We have considered adding more at a later date."

All of which brings us to the future, and VHF Translators. As C.E. Seide of KNOP has pointed out, \$2,000 will install a VHF repeater station. You can spend more, but even a free cash man would be hard pressed to spend more than \$3,000 for a first class one watt VHF Translator installation. That this comparative low cost method of extending a TV station's coverage is attracting the interest of TV Broadcasters around the country is not surprising. But, a TV

Translator must operate on a clear channel and create no in-

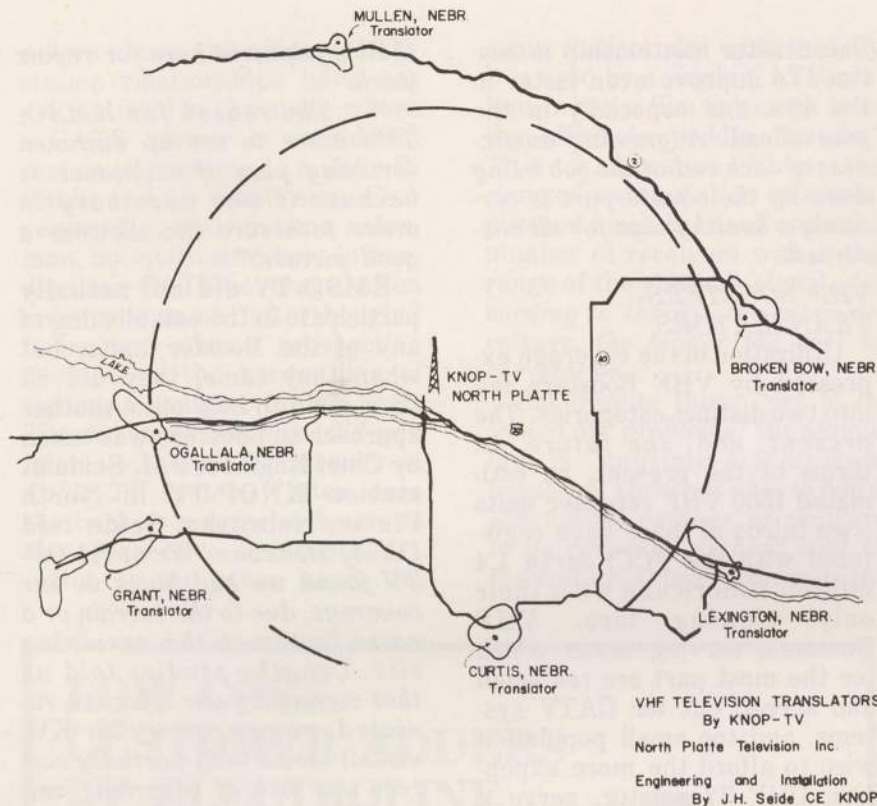

terference to off the air reception. In most areas of the congested eastern two thirds of the country, few such channels exist. Nonetheless, Broadcasters have been filing form 346 with the FCC in increasing numbers in past weeks, with one apparent aim in mind. "Where geography does not allow their primary signal to penetrate a nearby (but not close enough) secondary market, the opportunity to erect a low cost VHF Translator, to serve that market, seems golden indeed." Cases to point: WLOS-TV, channel 13 in Asheville, North Carolina has filed for three VHF Translators to repeat its signal on channel two into the Tennessee towns of Bristol-Kingsport and Johnson City, in affect giving WLOS primary coverage in the bulk of these three towns. Total added receivers: 30,000 plus. Total cost, approximately \$7,000! Combined total of sets with WLOS market area of 29,000 sets; 59,000 sets!

Oh yes, Johnson City-Bristol-Kingsport has a local station, WJHL. Will they contest the applications? YOU BET THEY WILL!

Second case to point: WLVA-TV filed for a construction per-

mit to construct a channel 5 VHF Translator in Roanoke, Va. WLVA, in Lynchburg, cannot now claim Roanoke coverage. Meanwhile WSL-12 and WDBJ-7, licensed to Roanoke, have protested the application before the FCC, claiming WLVA is attempting to become a two market station.

Meanwhile an additional twist has been dumped into the FCC's lap, which it is felt, never meant the VHF Translator service to cover any area now receiving adequate off the air reception.

WRVA-12, Richmond, Virginia has filed for construction permits to build VHF Translators in Harrisonburg and Staunton, Virginia. Harrisonburg has a local station (WSVA-3), Staunton does not. WRVA is carried on the Staunton Video Corporation Cable System, and the Harrisonburg Trans-Video Company Cable System in that city. Apparently not satisfied with its "bonus Cable coverage," WRVA has applied for VHF Translators in the two towns.

Similar filings have been made in Ponce, Puerto Rico, Rome, New York, and Canadian, Texas. Some VHF Translator manufacturers believe "the really big market" for their

product will finally be not the local Civic Groups, but with the stations themselves. It will probably take the next Convention of the National Association of Broadcasters, and a ruling on the contested "market hopping application" of WLVA in Lynchburg, Virginia, by the FCC, to decide the matter once and for all.

Certainly the aggressive Broadcasters are filing their applications early, fearful that other competitors will beat them to the draw.

Our industry, composed of three very much proven methods of bringing television reception to homes now devoid, or lacking sufficient diversification of programs, is on the verge of one of the biggest expansion periods in communications. Soon, perhaps, the FCC's allocation dream of "television for everyone" will become a reality.

In the June 1961 issue of TVH, editor Bob Cooper noted the emergence of local origination and the first beginnings of "pay-cable" type services. The following "Editorial" appeared in the same issue which was distributed to the 1961 NCTA convention conclave in San Francisco.

EDITORIAL

When *Horizons* Publisher Bob Cooper appeared before the Seattle Pacific Northwest CATV meeting in April he presented a luncheon talk on the subject of "Can CATV Operators Meet Competition." The talk was general on content and did not attempt to point up any "particular form of competition" although an intrepid listener might have suspected he was referring to Translators and/or local television.

The meat of Cooper's talk jelled down to "CATV systems have existed for a number of years in almost virgin market-places. They have operated without competition in almost all instances, and have been able to get by with second rate promotion efforts. Today however the threat of federal legislation and local translator activity in every cable-fed town in the nation is changing the situation."

"Today," said Cooper, "the CATV operator must first

awaken to the fact that he may at any time have competition, and secondly to the fact that competition in itself is not bad! In fact it may just be the thing the CATV operator needs to jar himself loose from a feeling of complacency."

Following the talk, several CATV operators in attendance admitted to Publisher Cooper he had hit home. Others had less to say. *No one disagreed.*

During the past 14 months a number of "Extras" have been dangled before the eyes of the nation's CATV operators. One of these is pay-TV via cable, a subject which will see yet further discussion in San Francisco. During the 1960 *Ninth Annual Convention* in Miami *TelePromTer* displayed a system of "key-TV." The approach to the *TelePromTer* system was through a direct pitch made to the CATV conclave by Irving Kahn, President of *TelePromTer*. The results of the public display were questionable. That the CATV operator was interested was not the question: That "he could afford to be interested" at a time when all phases of Cable TV were coming

under the scrutiny of pending federal legislation was the question.

This year's San Francisco CATV convention will see a similar "unveiling" of an "all-new" method of Pay-TV." As reported on page one of this issue, the display will be "National Telefilms Associates new division Home Entertainment Company" formed on May 18, for the expressed purpose of displaying this system to CATV operators.

Whether or not the nation's CATV operators show enthusiasm for the NTA system operators are very much searching for "that extra-plus service" which will distinguish their product (cabled-video) from whatever other entertainment the set-owner is able to tune-in on his twelve channel receiver.

The potential is not only great, it is unbelievably large. And properly handled it can become every bit as profitable as any cable system in any virgin town ever turned out to be.

The CATV industry is ripe for a gimmick-system depreciation, taxes and competition all considered.

P.T. (Pay-TV?) Barnum... where are you?

MAY CATJ COVER REPRINTS

The May (1976) CATJ cover displayed a World War Two vintage tank (identified as an attack vehicle of the FCC's Cable Television Bureau); a re-creation of a World War Two era Bill Mauldin newspaper cartoon.

The message related to the FCC's present prosecution of the Gridley, Kansas CATV system for operating without an FCC Certificate of Compliance. There has been more (positive) reaction to that cover than any other cover run by CATJ to date. Which suggests to CATA that perhaps there is a way here to help out an ailing "Gridley Defense Fund"; the monetary fund established by CATA to pay for the legal costs of defending Gridley before the FCC and eventually within the federal court system.

We have therefore printed, on large poster stock (16" x 20") this cover in a format that is suitable for framing. The reproductions of the cover are serial numbered and only 100 prints have been made. This, therefore, is a "limited reproduction" and someday it might even have some "original art value" to collectors.

Each reproduction has been signed by CATA President Kyle D. Moore (owner of the Gridley, Kansas CATV system).

To order your own copy (which is of course suitable for wall display in a suitable frame), send \$25.00 (minimum) to CATA Defense Fund, Suite 106, 4209 NW 23rd, Oklahoma City, Ok. 73107. First come — first served.



Compact (14 inches high, 28 inches wide, 23 inches deep), low cost (\$1795.00*), third generation field proven version of the most popular CATV time/weather origination package in the industry. Displays time, temperature, barometric pressure, wind velocity, wind direction, plus displays four card spots. Sony AVC-1400 (2:1) interlace camera. Designed for 24 hour per day operation, and a minimum of maintenance.

* Deluxe Texas Electronics instrumentation available at slight additional cost.

WEATHER SCAN

Loop 132 — Throckmorton Highway
Olney, Texas 76374 — (817/564-5688)

The ULTIMATE time/weather origination package

WEATHERSCAN



TECHNICAL TOPICS

Editor:

Congratulations on your recent up date article concerning satellite terminals. As always your article has brought up some interesting questions. On behalf of Prodelin Corp., I thank you for the mention of our work in Santa Clara.

In conjunction with the slides enclosed, I would like to make the following comments in regard to the installation. Location of concrete pad was made such that we could look at all of the current satellites. This represents an angle of approximately 114 degrees for our location. The actual mounting pad consists of a 10 ft. x 10 ft. x 15 inches with reinforcing wire in the concrete. Location of these pads was accomplished by using the 2 x 4 triangle frame shown in the pictures. The assembly of the system took three of us approximately 2 days, including assembly of the reflector and preparing and pouring the pad. It should be noted that no special tools were used, only normal hand tools like end wrenches, etc.. The reflector is built in two pieces and was assembled in front of the pad. An interesting feature of the reflector is the alignment ring that bolts to the rear of the reflector. This alignment ring allows assembly in the field with no adjustment of panels or use of special tools and guarantees parabola accuracy to .050 of an inch. Should the FCC change frequency to the 14 GHz band, all that would be needed is a change of the feed assembly, which is accomplished in approximately 15 minutes. The mount is then tipped forward to the rear of the reflector. Attachment is made to the reflector. The mount and reflector are then tipped back by means of the come along. Finally the feed is installed and the installation is complete.

After completion of the terminal, we borrowed an L.N.A. with a 2.0 dB noise figure (170 degrees) and a video receiver with a T.V. monitor. Due to time, we were not able to make comprehensive tests (these will be made in the near future). Three of us agreed that the pictures were on the order of 51-52 S/N. I found it very interesting that the quality of the pictures was so good; particularly with all of the terrestrial microwave signals in our area. We saw approximately 50 carriers, yet no visible degradation to S/N. One of the tests planned is to measure these.

After looking at HBO, we shifted to the Anik Satellite. This was chosen because of the unmodulated carrier and knowledge of E.I.R.P. at our location. From this we were able to measure G/T (Gain over Temp). This came out to 19.8 dB.

A few comments on licensing smaller terminals. Part 25 of the FCC rules states the following:

- a. Any antenna to be employed in transmission at an earth station in the Communication/Satellite service shall conform to the following standard:

Outside the main beam, the gain of the antenna shall lie below the envelope defined by:

$$32 - 25 \log_{10} (\theta) \text{ dBi } 1^\circ \leq \theta \leq 48^\circ$$

$$10 \text{ dBi } 48^\circ \leq \theta \leq 180^\circ$$

Where θ is the angle in degrees from the axis of the main lobe, and dBi refers to dB relative to an isotropic radiator. For the purposes of this section, the peak gain of an indi-

vidual sidelobe may be reduced by averaging its peak level with the peaks of the nearest sidelobes on either side, or with the peaks of two nearest sidelobes on either side; provided that the level of no individual sidelobe exceeds the gain envelope by more than 6 dB.

- b. Any antenna employed for reception at an earth station in the communication/satellite service shall be protected from interference only to the degree to which harmful interference would not be expected to be caused to an earth station employing an antenna conforming to the antenna standard of paragraph (A).
- c. The authorization of any earth station antenna not conforming to the standard of paragraph (A) shall be so conditioned that the use of such an antenna shall impose no limitation upon the operations, location, or design of any terrestrial station, any other earth station, or any space station.

Please note that the requirement to meet the $32 - 25 \log_{10} \theta$ and $-10 \text{ dBi } 48^\circ$ to 180° is for transmit only. As a matter of interest, we are able to meet this with our 15 foot terminal. Attached is a radiation pattern of the 15 footer. Paragraph B and C of this regulation indicates that conditioning and protection of an antenna is

needed if harmful interference is present.

I believe if an operator takes the time and money to do a frequency plan on his location and includes this with his filing, providing there are no gross interfering signals, the FCC will grant the request. By this I mean take the time to measure the interfering signal that is objectionable, follow the second paragraph of the above rules and take steps to solve them. These steps can include blockage by means of shrouds, putting the terminal below ground level or consider relocating the terminal to take advantage of natural blockage, valleys, buildings, etc..

These problems are not new to the microwave industry and like anything else involving engineering, are simply problems that can usually be solved if attacked logically. This covers everything we have done to date. As additional testing and data becomes available, I will forward this to you.

Gerald E. Pell
Prodelin, Inc.
Santa Clara, CA. 95050

Jerry —

We want to take this point to note that during the month of June CATA (Community Antenna

RADIATION PATTERN PRODELIN 15ft. (4.57 Meters) EARTH STATION ANTENNA

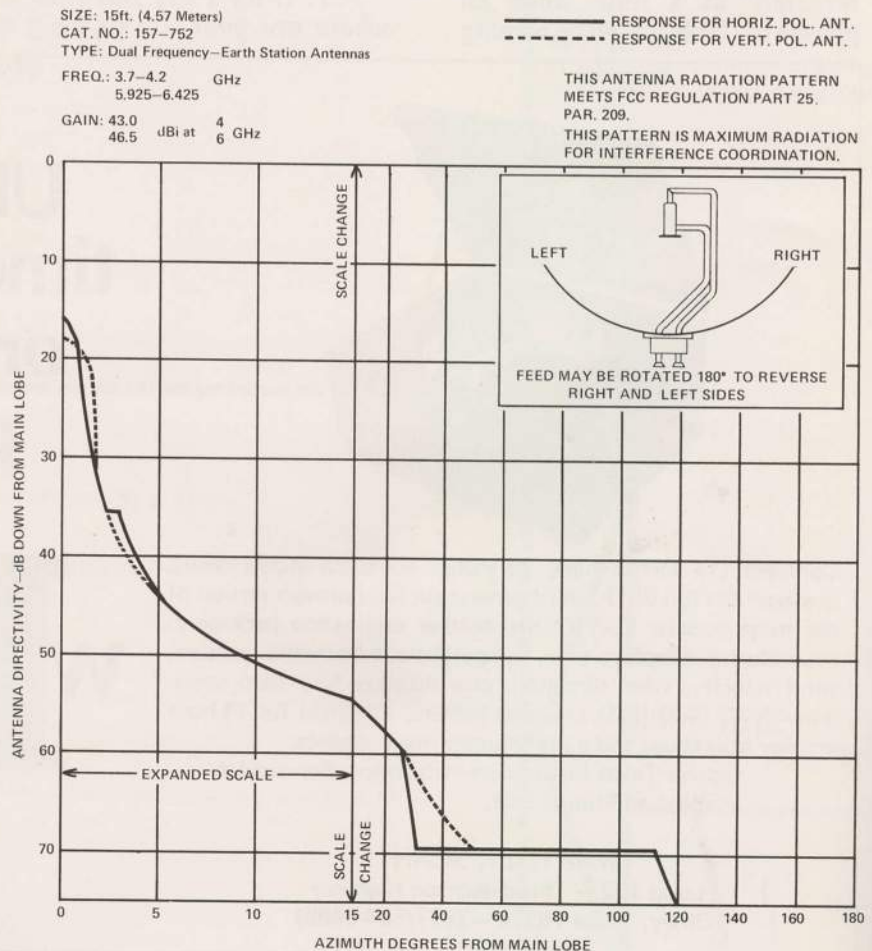

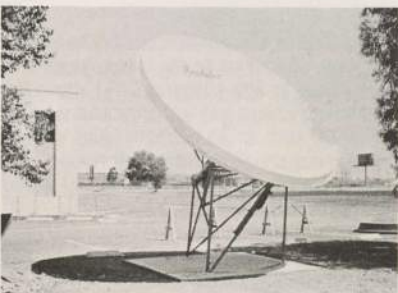

Television Association) filed a "Petition for Rule Making" at the FCC requesting that the Commission "take the wraps off" of earth terminal antenna size limitations officially, which would thereby clear the way for systems wishing to utilize small aperture antennas to do so. This rule making petition will hopefully go out for comment shortly, and we hope that all of those systems interested in smaller terminals (such as your 4.57 meter antenna terminal) will take the time to comment at the FCC.

We also wanted to correct an item appearing in the June CATJ in which we note that a recent Cities Service application for a small (4.5 meter) terminal had received FCC approval. Actually, it

turns out the Cities Service application was approved more than one year ago. The paperwork in the original request by Cities Service and the FCC response ran to well over 1,000 pages; an indication perhaps of the magnitude of the problem facing any operator who seeks to utilize a smaller-than-9 meter antenna under the present FCC rules. Unless the Commission removes the formal 9 meter limitation, we doubt that there would be much activity at the Commission in this area merely because someone filed an application as you suggest. John Panagos at Gaithersburg CATV in Maryland has found the Commission something less than interested in his small 10 foot horn application as we reported in the May CATJ.

Finally, we look forward to seeing the 4.5 meter terminal demonstrated at CCOS-76 August 9-11th at Sequoyah State Park near Wagoner, Oklahoma. For many of those attending, this will be the first exposure to CATV terminals of any size. As a result of the recent CATA filing requesting FCC re-assessment of the 9 meter criteria, we are hopeful that by CCOS-76 there will be an opportunity for the industry to really get involved in smaller terminals in a serious way.

LICENSING CABLE PERSONNEL

Editor:

This letter is in response to your survey concerning technical licensing by the F.C.C. I do not feel the F.C.C. should be involved in licensing technical personnel in the CATV industry.

I do feel our industry should set up a certification program whereby all CATV personnel can acquire certification in various fields of work activities. This certification program should be down to each area of activity such as normal installations, apartment wiring, pole line construction of hardware—of installing trunk and feeder—of splicing and of activation, customer servicing; system trouble shooting, feeder layout and design, trunk layout and design, running a system proof up to point of F.C.C. acceptance, antenna and head end service and maintenance, service LDS microwave, service common carrier microwave, closed circuit video, and etc.

One of the national association groups could make arrangement with personnel in various regional areas to monitor the written and demonstration portions of the examinations; results to be mailed to the national organization for grading and issuance of certificate.

This certification program would have several advantages as follows:

1. It would stimulate technical personnel in seeking more knowledge in the various fields of the CATV activities especially at companies that do not have an active training program.

2. These certificates can be used by systems for upgrading of personnel.

3. These certificates would be advantageous to personnel directors when interviewing and hiring technical personnel.

4. The F.C.C. could use these various certificates for setting up levels of competence in making the tests for compliance of the rules. Many of the tests that are required are very basic and do not need someone with a great knowledge of electronics capable of passing the second class F.C.C. tests. As an example, for 24 hour signal level readings in subscribers homes—someone certified in the use and technical operation of the FSM would be required, and so on for the various measurements in the

F.C.C. rules.

I feel that if the F.C.C. required all technical personnel to have F.C.C. license, that the majority of the technical personnel in the industry would not be able to pass the examinations, should the examinations be similar in skill level as the first and second class examinations.

This would (a) create a financial burden on a great number of technical personnel who cannot afford to acquire the additional skills to pass the examination, (b) increase the financial responsibilities of the CATV systems by way of increased expenses in training programs, and higher wages, (c) cause the industry to lose a lot of good CATV personnel should they not be able to afford the additional training or the CATV companies not meet their obligation of training their personnel.

The certification by each area of activity gives the technical personnel smaller steps or goals which can be accomplished in a shorter period of time. From experience in observing and training personnel I have found that these small stepping stones develop pride in the individuals, helps motivate and stimulate greater interests in their work.

Austin Coryell
Regional Engineer
ORANGE CABLEVISION
Orlando, FL. 32803

Austin —

The February (1976) CATJ contained the "survey card" which you address yourself to, and the April (1976) CATJ contained a preliminary report on the 'balloting' by those survey cards.

Approximately 3 survey respondents in four reacted as you do, i.e. there is a need for job classification by license grade, although you suggest (wisely we believe) that the license could actually be an industry certification program. The FCC has said recently that they have no "immediate plans for testing and licensing of CATV personnel." This is contrary to earlier statements and drafts we saw of proposed licensing requirements.

Contrary to what some may believe, we brought this whole matter up in February not to re-open a can of worms better left untouched, but rather to look for a positive alternative to what potentially can be a very important part of future-day cable system operations. History tells us that where an industry makes no effort on its own to accomplish some form of self-policing, that sooner or later some bureau of government will step in and establish standards for us. If we accept the latest FCC statements that they "have no intent of licensing CATV personnel... for now," and go on our merry way, we are probably creating a situation which will command the Commission to one day in the future "re-visit" the whole question.

So we feel your suggestion is timely and well thought out, this industry needs to develop its own industry-wide certification program. CATJ is the natural vehicle to do this because we have the resources of CATA at our right elbow. Consequently, a special study group has been formed to investigate how such a program might work, and who would administer the program. At CCOS-76, this study group will meet to create a working-committee to design the framework for such a national program. This will be an open meeting at the close of CCOS-76 on Wednesday, August 11th, and we hope that people such as yourself with your type of keen insight will join us there for this important meeting.

SATELLITE PRE-AMPS

Antenna mounting signal pre-amplifiers are one part of a typical satellite earth receiving terminal which most CATV operators identify with readily. As noted in previous CATJ reports on satellite receiving terminals (see **October 1975; February 1976 CATJ**), the pre-amplifier is an important part of the terminal mix, and it largely determines the type of signal to noise ratio you will get from the service.

And as noted previously, antenna pre-amplifiers in the 3.7-4.2 GHz band are currently in a moderate state of flux, with specifications improving and prices dropping almost monthly. A complete run-down of the current state of pricing and the art itself is beyond the scope of this limited short-form report. However, the following product line-up, from CATV supplier **Avantek** (3175 Bowers Avenue, Santa Clara, Ca. 95051) is representative of the changes that are taking place. Keep in mind that prices continue to fluctuate, and that pricing shown is largely list-quotation pricing.

For the 2.7 dB noise figure super-duper GaAs FET model SD-6-0293N, the price tag hovers around \$2,500.00. This is for 49 dB of signal gain.

Then there is an AM-4222 series with 3.0 dB noise figure, with standard coaxial connectors (as opposed to waveguide fittings) which run \$1825.00 (AM-4222 / 20 dB gain); \$1925.00 (AM-4223 / 28 dB gain); and \$1975.00 (AM-4226 / 49 dB gain).

And there is the AM-4232 series units with a 4.5 dB noise figure also with standard coaxial fittings which run \$1275.00 (AM-4232 / 18 dB gain); \$1325.00 (AM-4233 / 26 dB gain); \$1475.00 (AM-4236 / 47 dB gain).

Obviously, what you pay for first is noise figure, gain comes in small or large doses at fairly easy-to-take dollar increments. But that first bite, for low noise figure, is a large one to swallow.

The most recent data sheets from other-GaAs FET (non-cooled) antenna mounting pre-amplifier suppliers indicates that perhaps (we mean perhaps) **Amplica, Inc.** (780 Lakefield Rd., Westlake Village, Ca. 91361 / 213-889-8700) may have the lead (temporary or otherwise) in lowest noise figure. Their new model 502CSL has a data sheet noise figure spec of 1.8 dB over any 100 MHz span in the 3.7-4.2 GHz region; and 2.2 dB over the full 500 MHz span of the downlink band. The same amplifier is touted to have an "under 1.6 dB noise figure between 3.9 and 4.125 GHz."

NOAA WEATHER SERVICE — AGAIN

Industry response to the CATJ program for cable-carriage of NOAA (VHF) weather station transmissions (see **CATJ for January, 1976; page 10** and **CATJ for March, 1976, page 30**) started off with a bang and then fell into the doldrums.

Early on the program ran into a strange reaction from the weather bureau people. On the surface, they seemed anxious to assist, and to arrange for whatever information the CATV industry needed. But when actual field situations presented themselves, the tables turned quickly. One example was the Indianapolis, Indiana NOAA station personnel who simply refused to acknowledge the presence of CATV systems more than 40 miles from Indianapolis. The cable system wanted some assurance that when Indianapolis station was carried by a system 70 miles out from the city that the weather

bureau would provide additional area-ized warnings for the cable community area.

The Indianapolis weather bureau office declined.

Another system, located right on the outer "grade B" contour of the Chicago system was also turned down. The Chicago weather bureau station personnel refused to broadcast severe weather data information for the CATV town area, even though the town is located inside the coverage area of the Chicago NOAA station.

The weather bureau originally planned a nationwide network of some 335 NOAA stations. The "nationwide network" would cover around 40% of the nation's land area, but around 80% of the people (does that sound like the TV allocations program to you!!!). Cable seemed the obvious method of creating coverage for some of the unserved. But the NOAA people have had their difficulties turning their plan into reality. Of the 85 or so stations now operating, only four are new this year. There were supposed to be 17 new stations this spring. A nationwide bid for suppliers to construct the remaining 250 stations sent out by NOAA last fall to 220 bid applicants resulted in only four bids being returned.

In a word, the program seems terribly bogged down in red tape of the bureaucratic cut. This has angered some Congressmen, and Congressman Clarence J. Brown of Ohio, serving on the House Communication Subcommittee held hearings on the matter in mid-May. Congressman Brown wanted to know why the program was at a stand-still, and he called up as witnesses the NOAA people as well as some of the would-be suppliers and the WeatherAlert (receiver) people from Chicago.

The day of testimony produced conflicting statements from NOAA and "rest of the world". NOAA people maintained their program was moving ahead, "although it is not on schedule" they admitted. A group of independent telephone company operators, who had tried to bid on the construction and maintenance of stations, complained that the NOAA bidding requirements had precluded them from even bidding on the systems.

Congressman Brown wanted to know why his state, Ohio, had yet to get sufficient stations to cover the state's population centers, while adjacent states such as Kentucky already had a "state-wide" network. The answer was primarily silence from the NOAA people. Congressman Brown also wanted to know why NOAA has a "warehouse full of VHF transmitters" stored and yet is unable to get them installed. Again, silence.

NOAA appears to be holding out for new transmitter sites where (1) the sites can utilize 1 kW transmitters, and, (2) where somebody will locally take the responsibility for putting the stations on the air. The 1 kW transmitter power is desirable of course (the alternative is 330 watts), but as Congressman Brown asked, "What is the logic of holding up installation of new 330 watt units, and thereby denying any service to the people, for the eventual (perhaps many years away) permission to utilize the 1 kW transmitters?"

Silence from NOAA people.

Recently, to get the program moving without bureaucratic (at least federal) red tape, two states have taken on the responsibility on their own (Ronald Reagan would love this). Kentucky, utilizing the sites of eight Kentucky ETV network stations, is installing transmitters to cover all of the state. Four are in operation now; Lexington, Louisville, Covington and Ashland. The Louisville transmitter is on the new "split

frequency channel" of 162.475 MHz (normal channels are 162.4 and 162.55 MHz). Mike Arkes of WeatherAlert (the receiver people) advises he began shipping new receivers that tune the new split frequency on June first.

Mississippi, also utilizing the state's ETV network, is also installing NOAA system gear as this is written. This information did not go by Congressman Brown unnoticed. His office told CATJ, "It looks like the states can get this program moving when the federal people cannot."

Of the 17 stations listed as "slated for new operation before March 31st," in the January CATJ listing (pages 12 and 13), only four have gone on the air as of mid-May. They are Rochester, N.Y., Bay City, Michigan, Newport, Oregon and Forks, Washington.

The Congressman Brown hearings in effect gave NOAA a couple of months to get "their house in order." CATA submitted written testimony to the record in the case, pointing out the large number of problems which CATV companies have been having with the NOAA field people.

On the bright side, CATJ has learned that Bob Toner of Toner Cable Equipment Company (Hosham, Pa.) is doing an excellent job in getting systems throughout the United States set up to carry the NOAA VHF weather stations. At last report, more than 30 systems were working with Toner (Toner provides complete receiving systems from the special vertical 162 MHz yagi to pre-amps and signal processors where required) to add the NOAA broadcasts to their systems.

CAN SUBSCRIBERS HELP?

"Two months ago I began my subscription to CATJ. Although I am not working in any cable television capacity, CATJ has been a consistent and reliable source of information relating to my second occupation — MATV installation and service. And although my primary interest is in MATV, CATJ has brought out many aspects and problems of the cable television industry that I had been completely unaware of to this time. I think every cable television subscriber should be educated about the problems facing cable operators as depicted in "The Journal." Perhaps this would help tone down the complaints from subscribers!

I also have a suggestion which I think would be most informative to the cable industry who subscribes to and supports CATJ. How about publishing actions and authorizations relating to cable TV, such as are currently found in **Broadcasting** magazine? I believe most readers would appreciate this information as much of it would relate to them directly.

Finally, I want to note how very much I enjoy Bob Cooper's style of writing. He's easy going and personable with a sense of humor and it sure makes technical reading fun. Keep up the good work and keep on fighting for the cable industry... I'm sure they appreciate it!

John Phillips
Pleasanton, California 94566

John —

Granted the cable industry has never done a very good job of advising subscribers of their own vested interests in FCC and other restrictive policies laid down by one agency or another. And granted that if the subscribers knew about these actions, they would probably rise up en masse and march on the nearest FOB office in a protest march that even CB has not yet been able to create for the FCC. But... even with

Cooper's writing style, how in the world would you explain our technical problems to people that largely have yet to master their fine tuning controls?

Now as to publishing FCC actions, the suggestion has been made previously. FCC actions fall into several categories. There are actions that relate to cable TV systems (i.e. new applications for CAC's, new applications for CARS band microwave, cease and desist orders, applications to add channels, applications to serve new communities, etc., etc., etc.); and then there are FCC actions which relate to broadcasters. In this category there are new station applications, location and/or power/tower changes for broadcasters, new station grants, new stations on the air, old stations going off the air (some still do that!) and on and on and on. The photo here shows Editor-In-Chief Cooper standing beside just this year's FCC "News Releases". That pile, against one wall of his office, will exceed his 6 foot 2 inch height before the year is over. Is it worth four to six pages a month of valuable CATJ space to "replay" that material for the industry?



In short, does anybody really care that much? We'd like to hear from other readers on the subject.

LOOKING FOR HELP

"I am looking for a couple of good manager-technician type people who are interested in working in a growing small MSO operation. One man would locate in eastern Texas while the second would locate in northern Louisiana. Both should be capable of running their respective systems, and both will have at least part-time installer help. These are traditional type systems with the usual collection of off-air problems that require some expertise in headend operation. Who's interested?"

Ben Campbell
P.O. Box 34012
Dallas, Texas
75234

CATJ'S NEW WALL CHART

During June readers who had ordered the new CATJ "FCC COMPLIANCE TESTS WALL CHART" received their copy of this new 25 x 38 two color issue from CATJ and CATA.

The whole concept of "subjective testing" using a handy television receiver and one's "calibrated eyeballs" has come under close study recently. In informal discussions with members of the FCC Cable Television Bureau, CATJ learned that there is **no overt opposition** to eyeball or subjective testing; **providing** the system operator recognizes that subjective testing can never carry the weight of testing conducted with proper (and calibrated) test equipment.

It occurs to CATJ that what we are really

dealing with here is a double-entry. In the case of the truly small system operator, a fellow who simply has no budget for anything more complex than an SLM, subjective testing may be the **only** regular testing format available. On the opposite side of the ledger, a system that has the cash and inclination for adequate test equipment should approach subjective testing as a basic training ground for **all** system employees; right down to the gal who (wo)mans the office and keeps an eye on the system monitor in the office. If **every** system employee has a basic understanding of how subjective evaluation relates to real-hard-test numbers, the whole level of "communications" within the CATV company improves. Rather than an installer who calls in to tell you "the pictures look cruddy" you have



CREATING CO-CHANNEL — Interfering carrier generation equipment (MC-50) with a portion of the frequency (and level) monitoring equipment employed to prepare CATJ FCC Tests Wall Chart.



20 dB DOWN AND 20 kHz — A precision 20 kHz offset carrier generated in the CATJ Lab is beat against an off-air broadcast signal; at an interference level 20 dB below the off-air signal, to produce this photograph. Thirty-three similar co-channel photos are displayed in CATJ's new FCC Tests Wall Chart.

a fellow who calls in with "we've got between 4 and 5% hum mod on Elm Street".

Obviously such intelligence means much more to the guy who has to go out looking for "crud" than "the picture looks cruddy". All of which suggests that the new CATJ FCC Compliance Tests Wall Chart is more than a short course for the small system that has no budget for complex test equipment; it is a long and short of-it-all course for every system employee of every cable system.

One of the subject matters visited in the new wall chart is co-channel interference. To create co-channel for precise measurement and photography, CATJ went to our Lab and set up a Mid State Communications MC-50 signal generator (with simulated sync modulation) to beat against (i.e. mix with) a regular off-air broadcast signal. By monitoring the level and actual frequency of the off-air local broadcast signal, and simultaneously monitoring the level and the frequency of the MC-50 generator signal (using

Mid State Communications CM20M counters and the SP-2 Signal Processor), we were able to establish precise (within 1 dB) carrier relationships between the two RF sources. The displays were photographed from the monitor screen as rapidly as the proper carrier level relations could be dialed in on the MC-50 1 dB step output level control, and the two independent carrier source frequencies calibrated for precision control of the RF carrier beat between the two carriers. One photo here shows the heavily Mid State Communications equipment operating for local RF carrier generation during the project (note counter reads 55.2400 or within the 100 cycle window assigned to a channel 2 minus allocation). The second photo is a 20 dB down interfering carrier at a precise 20 kHz offset.

Many users of the CATJ Headend Wall Chart (first issued in 1974) have asked "How do you take all of the photographs under such varying off-air conditions?" (There are more than 90 off-screen photos in the Headend Wall Chart and

64 in the new FCC Tests Wall Chart.) Although the test equipment photograph included here shows no detail, behind the work bench with the Mid State Gear are several floor to ceiling racks of headend gear. There are six separate towers (up to 200 feet in height) at the CATJ Lab, loaded with more than 30 different VHF and UHF antenna arrays. All towers have rotatable antennas, which means in a sense we probably have the largest "search antenna system" in the industry today.

The 30-plus feedlines are brought into the Lab building in .412 and .750 formats and through a complex series of coaxial relays, virtually any antenna can be instantly switched to any number different receivers. Receivers are preceded by relay selected sets of bandpass filters, low noise pre-amplifiers, processors and so on. Banks of SLM units (much of the CATJ Lab equipment is on loan from helpful industry suppliers) constantly monitor various signals, driving chart recorders and other devices such as S/A's and on occasion video taping units.

CATA-torial — continued from page 5

So here we have the 8 majors (Paramount, Warner Brothers, etc.) demanding up-front money from the small theater operator, and a percentage of the gross (70% is not uncommon but it varies with the show; some have been as much as 90%). And we have the independents, who have less attractive films to offer, paying the theater operator up front for use of his hall and at the theater owner's option a percentage of the gross.

Many years ago the major motion picture producers owned and operated their own chains of theaters. But then the Department of Justice got into the act and through a "consent decree" reached a settlement with the producers wherein the producers stuck to production, and agreed under Anti-Trust threats to dispose of their theaters. This decision is still in effect today, and it was intended to largely protect the independent theater operators from being run out of business by the major producers who simply refuse to offer films to theaters they did not own and operate. More recently Warner Brothers tried the "four wall" approach now practiced by the independent producers, but the feds shook their finger at Warner and told them that "four walling is a no-no, under the consent decree."

There are today still major theater chains, and today many of these are owned and operated by "subsidiary corporations" or "related corporations" which trace back to the remaining Big-8 production companies, but by in large things have cleaned up quite a bit in that aspect of the theater business.

Today's movies are distributed under tight controls. The number of prints of a film is small (often no more than 25 to a tops of 50 nationwide) and their handling and care is a study in presidential security precautions. Independents, for example, bring the print to town, stay at the theater while it runs, counting the gate and carefully seeing that every person entering has paid the full ticket price. This "checker" procedure is practiced by the Big 8 majors as well, but they opt to send in a "Blind Checker" who stations himself (or herself) outside of the theater performing the count without the knowledge of the theater operator. When 500 people go in and out of a theater for a run but the "reported receipts" for a showing (and the subsequent payment to the distributor/producer) accounts for only 200 people, the distributors get downright "unfriendly." In one situation, not many years ago, a theater operator in the southeast was accused of "skimming" and the distributor and his producer filed a suit against the fellow. They checked and re-checked his books but could not prove he "was cheating". This went on for three years, and during that time the theater operator was denied use of any of the pictures of the 8 majors. When at the end of three years the 8 majors could not prove the accusation, the theater owner filed a countersuit for losses during that three year "boycott" period, and won in court. He very wisely "retired" with the modest proceeds from his countersuit, simply be-

cause after causing the Big-8 that much grief he knew he would never get any more product for his theater.

Years ago the Big-8 and their forerunners knew how to handle a guy like this. They would simply set up a competitor in the same town with profits from the productions and run the "independent" guy out of business. It has not been so long ago that the producers were still funding theaters as a means of getting better prices out of a lone-wolf operator. If a fellow owned all of the outlets in town, he knew the producers had no place else to go with their product; and he was stubborn about the percentage he would pay them. The Big-8 reacted by building a few competitive theaters in town.

Presently, the producers are more clever about accusing a theater operator of shorting them on the receipts. They know that for contractual and legislative (i.e. law) reasons they have up to three years after the incident to accuse a fellow of shorting them. Not long ago a theater operator found some distributors had been prying into his financial records and his bank accounts and even his IRS returns looking for evidence that he was "skimming" on them. To the distributors, this operator was "simply living too good" and "too high on the hog" for a man who was reporting the kind of receipts he was reporting to them.

In the CATV scenario developing, HBO and Optical are not unlike the distributors of today's motion picture business. They produce none of the movie product; they are merely a conduit for its distribution. Yes, HBO does produce a fair measure of sporting events and more recently live or videotaped theater and entertainment events; which is to their credit, at least for now. But already the Hollywood producers are out courting the bigger CATV operators, investigating and exploring "direct deals." They may be making "\$25.00 per week" kind of deals today, but we suspect the message is there; if this industry develops into a pay program distributor not unlike the motion picture theaters of the 40's and 50's and 60's, the "\$500. per week plus 70% of your gross deals" are but around the corner.

The message behind all of this is simply this: Caveat Emptor, or buyer beware. If it is true that a Leopard does not change his spots, our zealous entry into the seemingly "wonderful world of pay cable" may signal some very rocky and financially dangerous times ahead. In terms of CATV time, a five to seven year commitment to purchase or lease or lease-purchase an expensive earth terminal is an eternity. And in that period of time, if the rules of the game change, and we find our "\$25.00 per week" deals turning into "\$500.00 per week plus 70% of the gross" deals, we just might end up losing control of our own pay cable operations.

"My goodness but you have a deep throat," said the cable operator to the motion picture producer. The motion picture producer smiled.

"...but tell me, why are your jaws lined with such sharp teeth?"

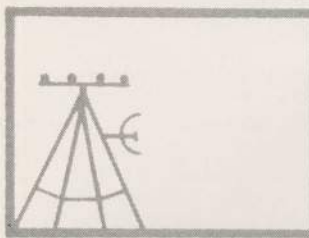

cata

ASSOCIATE MEMBER ROSTER

In recognition of the untiring support given to the nation's CATV operators, and their never-ending quest for advancement of the CATV art, the COMMUNITY ANTENNA TELEVISION ASSOCIATION recognizes with gratitude the efforts of the following equipment and service suppliers to the cable television industry, who have been accorded ASSOCIATE MEMBER STATUS in CATA, INC.

- Anixter-Pruzan, Inc.**, 1963 First Ave. S., Seattle, WA. 98134 (D1)
Avantek, Inc., 3175 Bowers Avenue, Santa Clara, CA. 95051 (M8)
Belden Corp., Electronic Division, Box 1327, Richmond, IN. 47374 (M3)
 BLONDER-TONGUE LABORATORIES, One Jake Brown Rd., Old Bridge, N.J. 08857 (M1, M2, M4, M5, M6, M7)
 BROADBAND ENGINEERING, INC., 535 E. Indiantown Rd., Jupiter, FL. 33458 (D9, replacement parts)
Burnup & Sims, Box 2431, W. Palm Beach, FL. 33401 (S2, S7, S8)
 CATEL, 1400-D Stierlin Road, Mt. View, CA. 94043 (M4, M9)
 Cerro Communications Products, Halls Mill Road, Freehold, N.J. 07729 (M3, M5, M7)
 COMM/SCOPE COMPANY, P.O. Box 2406, Hickory, N.C. 28601 (M3)
 ComSonics, Inc., P.O. Box 1106, Harrisonburg, VA. 22801 (M8, M9, S8, S9)
 CORAL, INC., 400 Ninth Street, Hoboken, N.J. 07030 (M1, M4, M5, M6, M7, D3)
 DELTA BENCO CASCADE INC., 40 Comet Ave., Buffalo, N.Y. 14216 (M4, M7, M8, D3, S8)
Jerry Conn & Associates, 550 Cleveland Ave., Chambersburg, PA. 17201 (D3, D5, D6, D7)
C-COR ELECTRONICS, Inc., 60 Decibel Rd., State College, PA. 16801 (M1, M4, M5, S1, S2, S8)
DAVCO, INC., P.O. Box 861, Batesville, AR. 72501 (D1, S1, S2, S8)
ENTRON, Inc., 70-31 84th Street, Glendale, N.Y. 11227 (M4, M5, D4, D5, S8)
 GAMCO INDUSTRIES, INC., 317 Cox St., Roselle, N.J. 07203 (M5)
JERROLD Electronics Corp., 200 Witmer Road, Horsham, PA. 19044 (M1, M2, M4, M5, M6, M7, D3, D8, S1, S2, S3, S8)
 Kay Electronics Corp., 12 Maple Avenue, Pine Brook, N.J. 07058 (M8)
 Magnavox CATV Division, 133 West Seneca St., Manlius, N.Y. 13104 (M1)
Microwave Filter Co., 6743 Kinne St., Box 103, E. Syracuse, N.Y. 13057 (M5, bandpass filters)
MID STATE Communications, Inc., P.O. Box 203, Beech Grove, IN. 46107 (M8)
 Pro-Com Electronics, P.O. Box 427, Poughkeepsie, N.Y. 12601 (M5)
 PRODELIN, INC., 1350 Duane Avenue, Santa Clara, CA. 95050 (M2, M3, M7, S2)
 Q-Bit Corporation, P.O. Box 2208, Melbourne, FL. 32901 (M4)
QE Manufacturing Co., Box 227, New Berlin, PA. 17855 (M9, tools & equipment)
RMS CATV Division, 50 Antin Place, Bronx, N.Y. 10462 (M5, M7)
 Sadelco, Inc., 299 Park Avenue, Weehawken, N.J. 07087 (M8)
 Scientific Atlantic, Inc., 3845 Pleasantdale Rd., Atlanta, GA. 30340 (M1, M2, M4, M8, S1, S2, S3, S8)
 SITCO Antennas, P.O. Box 20456, Portland, OR. 97220 (D2, D3, D4, D5, D6, D7, D9, M2, M4, M5, M6, M9)
 Systems Wire and Cable, Inc., P.O. Box 21007, Phoenix, AZ. 85036 (M3)
TEXSCAN Corp., 2446 N. Shadeland Ave., Indianapolis, IN. 46219 (M8, bandpass filters)
Theta-Com, P.O. Box 9728, Phoenix, AZ. 85068 (M1, M4, M5, M7, M8, S1, S2, S3, S8, AML Microwave)
TIMES WIRE & CABLE CO., 358 Hall Avenue, Wallingford, CT. 06492 (M3)
 Titsch Publishing, Inc., P.O. Box 4305, Denver, CO. 80204 (S6)
 Tocom, Inc., P.O. Box 47066, Dallas, TX. 75247 (M1, M4, M5, Converters)
 TOMCO COMMUNICATIONS, INC., 1132 Independence Ave., Mt. View, CA. 94043 (M4, M5, M9)
TONER Cable Equipment, Inc., 418 Caredean Drive, Horsham, PA. 19044 (D2, D3, D4, D5, D6, D7)
 Van Ladder, Inc., P.O. Box 709, Spencer, Iowa 51301 (M9, automated ladder equipment)
WAVETEK Indiana, 66 N. First Ave., Beech Grove, IN. 46107 (M8)
 Western Communication Service, Box 347, San Angelo, TX. 76901 (M2, Towers)

NOTE: Associates listed in bold face are Charter Members)

Distributors:

- D1—Full CATV equipment line
- D2—CATV antennas
- D3—CATV cable
- D4—CATV amplifiers
- D5—CATV passives
- D6—CATV hardware
- D7—CATV connectors
- D8—CATV test equipment

Manufacturers:

- M1—Full CATV equipment line
- M2—CATV antennas
- M3—CATV cable
- M4—CATV amplifiers
- M5—CATV passives
- M6—CATV hardware
- M7—CATV connectors
- M8—CATV test equipment

Service Firms:

- S1—CATV contracting
- S2—CATV construction
- S3—CATV financing
- S4—CATV software
- S5—CATV billing services
- S6—CATV publishing
- S7—CATV drop installation
- S8—CATV engineering

NEW JERROLD TAPS

Future Feature Taps are new from **Jerrold** and complete specifications are available from the company at 200 Witmer Road, Horsham, Pa. 19044.

The new tap line has a 7 amp power-passing capability, 30 dB tap-to-tap isolation rating, a woven continuous metallic gasket for RFI protection, chromated and coated weatherproof housings and specifications from 5 to 300 MHz.

MAGNAVOX BROADBAND DESCRAMBLER

The **Magnavox CATV Division** (133 West Seneca, Manlius, N.Y. 13104) reports production has begun on a broadband "descrambler" set-top unit; the MX-MU-1. This unit has "output" bandwidths of either 54 to 88 MHz or 130 to 200 MHz.

Full information on the unit is available from Magnavox.



TWO CHANNEL PAY TRAP

Vitek Electronics (200 Wood Avenue, Middlesex, N.J. 08846) has introduced a two-channel pay cable (security) trap. Using the same design and production format of their now well known single channel (cable section) traps, VITEK's new two-channel unit claims selected carrier attenuations of 70 dB or more.

The cost increase, for the two-channel model over the earlier single channel model, is approx-



imately 50%. By using the two-channel version "going in" the cable system is able to utilize one dedicated channel for pay at this time, and reserve a second channel (pre-trapped) for additional pay offerings at a later date.

COMSONICS PATENT AWARD

An interesting conceptual patent has been awarded to Glen Shomo, III of the Research and

Development Laboratory of Comsonics, Inc. of Harrisonburg, Virginia. Under the patent, a cable system can turn an existing one-way only system into a two-way system by utilizing the frequency range 10 kHz to 300 kHz for return-direction signaling applications. Under the disclosures in the patent, Comsonics has 'discovered' that existing cable systems have a 'transparent window' for both the up and down stream signals in that frequency range.

One specific application is for the cable system to utilize this frequency range (and equipment provided by Comsonics) to control by remote switching headend non-duplication equipment.

RECENT CONN APPOINTMENTS

Jerry Conn and Associates, manufacturer's representatives serving the six state region of Delaware, Maryland, Ohio, Pennsylvania, Virginia and West Virginia from its offices in Chambersburg, Pennsylvania has recently been appointed to handle representation for several additional CATV related lines.

Included in this expansion (JCA now represents 13 manufacturers of cable and cable related equipment) are **Amatek** (Palo Alto, California), **Electroline** (Montreal, Quebec), **Control Technology** (Garland, Texas), **Triple Crown Electronics** (Rexdale, Ontario) and **VITEK Electronics** (Middlesex, N.J.).

AVANTEK VIDEOTAPE AVAILABLE

Avantek, Inc. (3175 Bowers Avenue, Santa Clara, Ca. 95051) now has available a 20 minute color videotape which demonstrates the applications of their Model CA-100A Time Domain Reflectometer.

A package consisting of the videotape, a CA-100A and a set of the appropriate manuals is available for loan to any CATV system, or the videotape may be purchased outright for a nominal \$40.00 (plus postage) charge. Arrangements for the loan of the equipment and tape may be made with William Le Doux at Avantek (408/249-0700).

KAY 9059 SWEEP

Kay Elemetrics Corporation (12 Maple Avenue, Pine Brook, N.J. 07057) has announced a new moderately priced CATV sweep system; the model 9059. Covering 1 to 300 MHz with a variable sweep rate of from 2 mS to 10 mS the 9059 can be adjusted for time-between-sweeps of from 1 sweep or scan every 20 mS up to 1 sweep or scan every 8 seconds.



The 9059 has start-stop frequency (width) controls allowing the operator to select the range of frequencies of interest. A CW output is also available for initial level set. In most applications the sweep level is set 15 dB above the CATV carrier signals. The unit has a +60 dBmV RF

output level (maximum) flat (with ALC) to within ± 0.25 dB.

The unit also has a built-in detector and optional frequency markers which would make it handy for general all purpose sweeping applications. Price of the unit is \$845.00.

NEW VAN BODY

Van Ladder, Inc. (P.O. Box 709, Spencer, Iowa 51301) has expanded their product line to include a new modular fiberglass body which has a number of unique features.

The 220 pound unit fits onto your pick-up truck bed forming an enclosed container not unlike a "camper" add-on. However the unit is designed so that various sections of it can remove in the form of self-contained modules, and in this way the modules can be removed from the truck at night for safe-storage or for restocking for the next day's work.

According to Van Ladder, this removeable feature allows the truck to function with maximum time in the field, and improves the control of truck inventory as well as truck inventory control. A full data sheet is available from Van Ladder, Inc.

SADELCO'S DIGITAL SLM

Sadelco, Inc. (299 Park Avenue, Weehawken, N.J. 07087) displayed their industry-first digital read-out signal level meter at the recent April trade show in Dallas.

Digit-Level 100 has three large readouts which function in 0.1 dB steps over a 90 dB dynamic range. The readout automatically adjusts for ambient light level present for maximum viewability, and also have a unique in-line analog meter for easy tuning.

Powering is via an internal NiCad system or with standard 117 VAC mains. The unit has a built-in speaker for audio and a dual Schottky

Diode high efficiency peak detector.

RECENT C-COR DEVELOPMENTS

C-COR Electronics, Inc. (60 Decibel Road, State College, Pa. 16801) has appointed OAK-Holland as distributor in Europe for the C-COR line of electronic equipment for the CATV industry. C-COR equipment to be marketed in Europe has a 40 MHz low frequency cut-off (to accommodate the slightly lower television band allocations in Europe) as well as 50 Hz powering.

A new indoor, multiple-channel line-up of amplifiers has also been introduced by C-COR. The I-4XX family of indoor amplifiers include hybrid design; 41 dB of gain; optional two-way filters and reverse band capabilities; powering voltages in the standard ranges from 30 volts to 230 volts, 50 or 60 Hz; plug-in fixed or thermal bandwidth limiting of 220 MHz, 245 MHz, 270 MHz and 300 MHz. The C-Cor Surge Protection Model, SPM, is also available as an option.

One year ago C-COR announced a new line of CATV plant standby powering, and this included a feature article on the subject in the May 1975 CATJ (pages 9-12). The company has announced a second type of standby power unit which utilizes a recently developed type of wet lead acid antimony battery, used extensively in spacecraft applications. This new battery type has a high pressure seal which eliminates any need for adding water (or other maintenance), and is available in two output voltages; 12 and 24 volts (DC). The product is dubbed the SPU-12 and SPU-24. The SPU-12 provides more than 30 hours of stand-by operation at 300 mA and 12 volts while the SPU-24 provides 3.5 hours of standby at a full 1 amp load. The self contained unit is installed on the cable plant messenger and it features automatic switch-over in the event of plant power failure with solid-state switching.



VIDCOM

INTERNATIONAL MARKET FOR VIDEOCOMMUNICATION

*Videocassettes — Videodiscs — Cable Television Equipment
Production Equipment — Duplication Equipment*

incorporating

MIPCOM

International Market for Communication Programs

VIDEO '76

*International Video/Cable Conference
Organized by the EBAV Group (Sweden)*

September 23-28, 1976
Palais des Festivals
Cannes, France

For six days, Cannes (France) will be the international meeting place for the video community world-wide: Equipment manufacturers (cassette, disc, and cable), program producers, program distributors, educators, users. If you are involved in video, or planning to become involved, and if you are interested in the international market, you cannot afford to miss VIDCOM.

Contact us for information on special group air fares.

U.S.A.
c/o JOHN NATHAN
30 Rockefeller Plaza
Suite 4535
New York, NY 10020
(212) 489-1360

FRANCE
Commissariat Général
3, rue Garnier
92200 Neuilly
France
747-8400

GREAT BRITAIN
Int'l. Equipment &
Services Exhibition
Organization Ltd.
8 Dorset Square
London NW1
(01) 723-8232
LIZ SOKOSKI
U.K. Representative

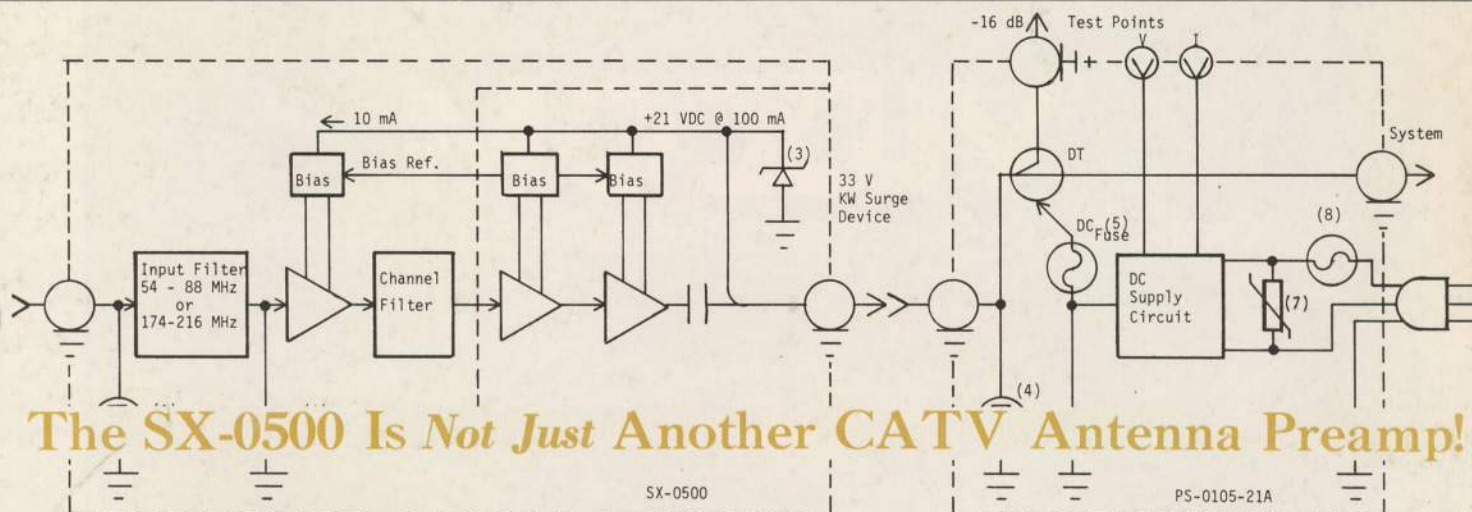

The SX-0500 Is Not Just Another CATV Antenna Preamp!

3 Pole Filter	1.5 dB Noise Figure Stage	3 Pole, 2 zero Elliptical Filter 6 MHz Flat -22dB+9 MHz $\le 5\text{ nS}$ Delay Distortion	3.5 dB Noise Figure, 2-Stage Broadband Amplifier. Low Intermod's, back matched over entire VHF Band	2-Transistor Regulated Supply Current foldback short circuit protection Test Points for system checks	Total Gain > +30 dB
Gain -0.3 dB	+10 dB	-1 dB	+22 dB	-0.3 dB	

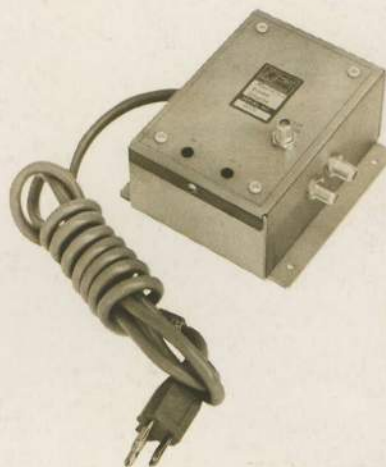
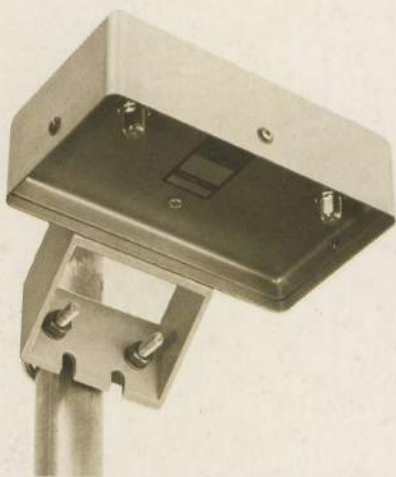

Q-bit Corporation's SX-0500 VHF Preamp design goes far beyond delivering gain and a low noise figure.

Compare all these equally important operational features:

- ◆ 8 points of lightning and surge protection ●●● Field-proven effective.
- ◆ Additional transistors used to bias the RF transistors results in stable and reliable operation from -50°F to +140°F. Likewise, any transistor can be changed without any realignment required.
- ◆ Selective channel filtering with low delay distortion and buffered from input/output interfaces.
- ◆ High level output stages for low intermodulation distortion.
- ◆ Test points in the power source for meaningful system tests without disturbing operations.
- ◆ Each amplifier noise figure is measured with a certified AIL noise source. This and other test data is supplied with each unit.

We do all this (including power source and mounting hardware) for only \$139.50.

30 dB UHF single channel and broadband preamplifiers also available.

For more information on all CATV products, write or call:



Q-BIT CORPORATION
 P. O. Box 2208
 Melbourne, Florida 32901
 Telephone: (305) 727-1838